

## Section 1

## INTRODUCTION

**1.0 General** — The IQ-1000 II™ is a self-contained, door-mounted, motor protection device which may be applied to 50 Hz or 60 Hz 3-phase motor starters or switchgear, including low-, medium-, and high-voltage equipment.

The IQ-1000 II monitors 3-phase AC motor currents to develop an accurate thermal model of motor heating. A separate RTD Module option allows the IQ-1000 II to combine the monitored motor stator temperature with the motor current information. The resulting combination of data allows the IQ-1000 II to develop a more detailed picture of the motor's temperature, thereby maximizing motor utilization.

The IQ-1000 II operates by monitoring motor current, and takes the motor off-line when it detects a problem such as an overcurrent or overtemperature condition. If an operating parameter exceeds its setpoint value, the IQ-1000 II initiates a trip condition.

**1.1 Contents/Use of Manual** — This manual contains the following sections:

**A — IQ-1000 TO IQ-1000 II Upgrade.**

**1 — Introduction.**

**2 — Hardware Description.** Itemizes the hardware features and lists the specifications of the IQ-1000 II.

**3 — Functional Theory.** Describes how the hardware and software function together to control, monitor, and protect the motor.

**4 — Operator Panel.** Describes the uses of the Operator Panel. Various operations such as loading setpoints or examining metered data are described.

**5 — Installation.** Outlines the installation procedures to be followed by a plant electrician or wiring crew when installing the IQ-1000 II.

**6 — Startup.** Lists step-by-step procedures to follow when first applying power to the IQ-1000 II.

**7 — Application Considerations.** Intended as an aid to the application engineer considering how and when to apply the various features of the IQ-1000 II. Hardware characteristics as well as set point and control background information are included.

**8 — Programming the IQ-1000 II And Set Point Description.** Lists the various application considerations associated with each of the functions of the IQ-1000 II. Available setpoint ranges or settings are detailed.

**9 — Troubleshooting.** Provides background information on

how to use the Operator Panel to recognize malfunctions. Also, a specific troubleshooting approach is listed.

The manual is broad enough in scope for new employee familiarization, refresher training sessions, and ongoing maintenance, installation, troubleshooting and unit replacement (if necessary) of the IQ-1000 II.

This manual contains information of specific importance for the user application engineer who is planning the motor control system and who is determining the setpoint values for the IQ-1000 II.

It is strongly advised that the application engineer carefully read Sections 2 thru 8 before beginning the application's Wiring Plan Drawings and Set Point Record Sheet. Installation teams should carefully read all of Section 5, Installation, and all previous sections, before starting final installation. Maintenance personnel should be familiar with Sections 2 thru 9 before attempting to service the IQ-1000 II.

**1.2 Product Overview** — The IQ-1000 II offers 52 operating setpoints, each referred to as a function. The setpoints associated with these functions are individually entered through the Operator Panel located on the front of the IQ-1000 II.

The functions consist of the following types of entries:

- **Alarm Relay condition settings.** An Alarm Relay closes when various conditions, such as motor currents or temperatures, exceed the selected setpoints. The alarm serves as an early warning. The motor's operation is not affected.
- **Trip Relay condition settings.** A Trip Relay closes (or opens) when various conditions, such as motor current or temperature, exceed separately selected setpoints. Action of the Trip Relay is user-selectable.
- **Auxiliary Trip Relay condition setting.** The auxiliary Trip Relay changes state when a user-selected condition, such as Instantaneous Overcurrent, exceeds a separately selected setpoint. Action of the Auxiliary Trip Relay is user-selectable.
- **Specific application-related information.** Entries such as the ratio of the current transformers or the incoming AC line frequency are required by the IQ-1000 II to properly monitor the motor.

Together, the functions tailor the IQ-1000 II for each specific application. After entry is completed, the setpoint values can be examined or modified. The actual values are stored in a non-volatile memory requiring no backup batteries or special

**Table 1.A**  
**COMMUNICATIONS OPTIONS**

<p>IMPACC, a Westinghouse Local Area Network, can be used to communicate with one or multiple IMPACC-compatible devices. These devices include the following: IQ-500, IQ-1000, IQ-1000 II, IQ Data Plus, IQ Data Plus II, IQ Data, IQ Generator, Digitrip, Addressable Relay II Advantage Motor Starters and IQ Energy Sentinels. Up to 1000 devices can be connected on a network via shielded twisted pair wire. Four different communication levels are available and are described below:</p>	
IMPACC Series I	Standardized software package that runs on a 100% IBM-compatible computer. The software is packaged with a computer interface card (CONI). Series I offers the following features: System Monitoring, Data Logging, Event Logging, Remote On/Off Control, Dialup Capabilities and Gateway Interface.
IMPACC Series II	Customer-written software for special applications. Custom software is required in situations where (1) Westinghouse software does not provide feature(s) desired by customer or (2) Customer wants to communicate to a non-IBM compatible computer or a Programmable Controller. A MINT translator module converts device-messages into 10-byte ASCII RS-232 signal. An RS-232 Protocol Manual is included with each MINT.
IMPACC Series III	Standardized software package that runs on most 100% IBM-compatible computers. Series III requires a CONI or a MINT to operate. Series III runs in the Microsoft Windows environment and includes the following features: System Monitoring, Data Trending, Event Logging, Spreadsheet-compatible Trend and Log files, Remote On/Off Control, Gateway Interface, Device/System Alarming, Analog Alarming, Security (password protection) and Enhanced Graphics.
IMPACC Driver Software (Third Party Vendors)	Data acquisition software written by third party vendors. Software drivers are available to gather data from systems such as IMPACC, Programmable Controllers and/or Energy Management Systems. The IMPACC Driver for ICONICS' Genesis (real-time graphics interface program) offers the following features: System Monitoring, Data Trending, Event Logging, Remote On/Off Control, Device/System Alarming, Customized Graphics and Communications to other Genesis-compatible systems (PLC's, Energy Management Systems). Other third party graphics interface programs include Wonderware's InTouch, Intellution's® FIX DMAPCS™ and Expert Edge's ROCKY®.

power supplies. In instances where a particular function is not required, it can usually be bypassed by entering a specific disable value.

**1.3 Options** — Options associated with the IQ-1000 II consist of external hardware. The following options are available:

- **RTD Module Option.** The RTD Module option is required when resistance temperature devices (RTD) are used to monitor motor winding, load and/or motor bearing temperatures. An auxiliary RTD connection is provided on the RTD Module for monitoring one additional location (such as motor case temperature).
- **Communications Options.** The Communications Options, listed in Table 1.A, provide motor data/status to a remote device such as a computer.
- **IQ DC Power Supply** — The IQ DC Power supply is required only when 40 VDC to 250 VDC control power is available.

**1.4 External Hardware** — The following items are required in addition to the IQ-1000 II.

- **Current transformers.** Current transformers are used by the IQ-1000 II to obtain load current information. Current transformers with 5 amp secondaries and ratios ranging from 10:5 to 4000:5 can be used.
- **Ground fault transformer.** A ground fault transformer with a 50:5 ratio can be used with the IQ-1000 II in grounded system applications to provide ground fault protection.

**1.5 Protection Features** — A list of protection features with the IEEE device numbers is contained in Table 1.B.

**1.6 Level of Repair** — This manual is written with the assumption that only unit-level troubleshooting will be performed. If the cause of a malfunction is traced to the IQ-1000 II unit, it should be replaced with a spare. The malfunctioning IQ-1000 II should then be returned to Westinghouse for factory repairs.

**Table 1.B**  
**IQ-1000 II PROTECTION FEATURES**

Feature	IEEE Device Number
Locked-rotor current	Device 51
Ultimate trip current	Device 51
Maximum allowable stall time	
I <sup>2</sup> T alarm level	Device 74
Instantaneous overcurrent	Device 50
–Programmable trip level and start delay	
Zero sequence ground fault trip	Device 50G/51G
–Programmable trip level, start delay and run delay	
Motor overtemp trip and alarm (Universal RTD Module with 11 RTD inputs available as an option)	
–Six stator windings	Device 49
–Two motor bearings	Device 38
–Two load bearings	Device 38
–One auxiliary	
Jam trip and alarm	
–Separate trip and alarm levels, programmable start and run delays	
Underload trip and alarm	Device 37
–Separate trip and alarm levels, programmable start and run delays	
Phase loss and phase unbalance trip and alarm	Device 46
–programmable alarm and run delay	
Number of motor “starts” allowed per time period	Device 66
–programmable starts and time period	
Anti-backspin time delay	
–programmable timer	
Transition trip for reduced voltage starters	
Incomplete sequence delay	Device 2/19
–programmable timer	
Phase reversal for non-reversing starters	Device 46
Trip mode	
–Mode 1: Trip relay energizes on trip condition	
–Mode 2: Trip relay energizes on powerup and deenergizes on trip condition or loss of power	
Selection of trip, reset, differential trip or motor stop on remote input	
Frequency selection	
–50 or 60 Hz	
Selection of auto or manual reset for I <sup>2</sup> T trip	

**1.7 Factory Correspondence** — All correspondence with Westinghouse, whether verbal or written, should include the “software version” number. This number appears in the display window when the Program mode is first entered, or the

program menu is first initiated (this is item 0 in Table 8.B). The software version number is used by Westinghouse to identify the specific IQ-1000 II type being discussed.

## Section 2

## HARDWARE DESCRIPTION

**2.0 General** — This section will familiarize the reader with the IQ-1000 II hardware, its nomenclature, and lists the specifications of the unit.

**2.1 Hardware Description** — The hardware description is divided into the following areas:

- Operator Panel (Par. 2.1.1)
- Rear access area (Par. 2.1.2)
- Options (Par. 2.1.3)
- Specifications (Par. 2.2)

**2.1.1 Operator Panel** — The Operator Panel, which is normally accessible from the outside of the enclosure door, provides a means to:

- Monitor the actual metered values on the Display Window. (Figure 2.1 shows the Operator Panel.)
- Enter or modify the IQ-1000 II's setpoint values or settings.
- Step through the program or run-monitor menus while running.
- Determine that a trip or alarm condition exists by means of two distinct LEDs.

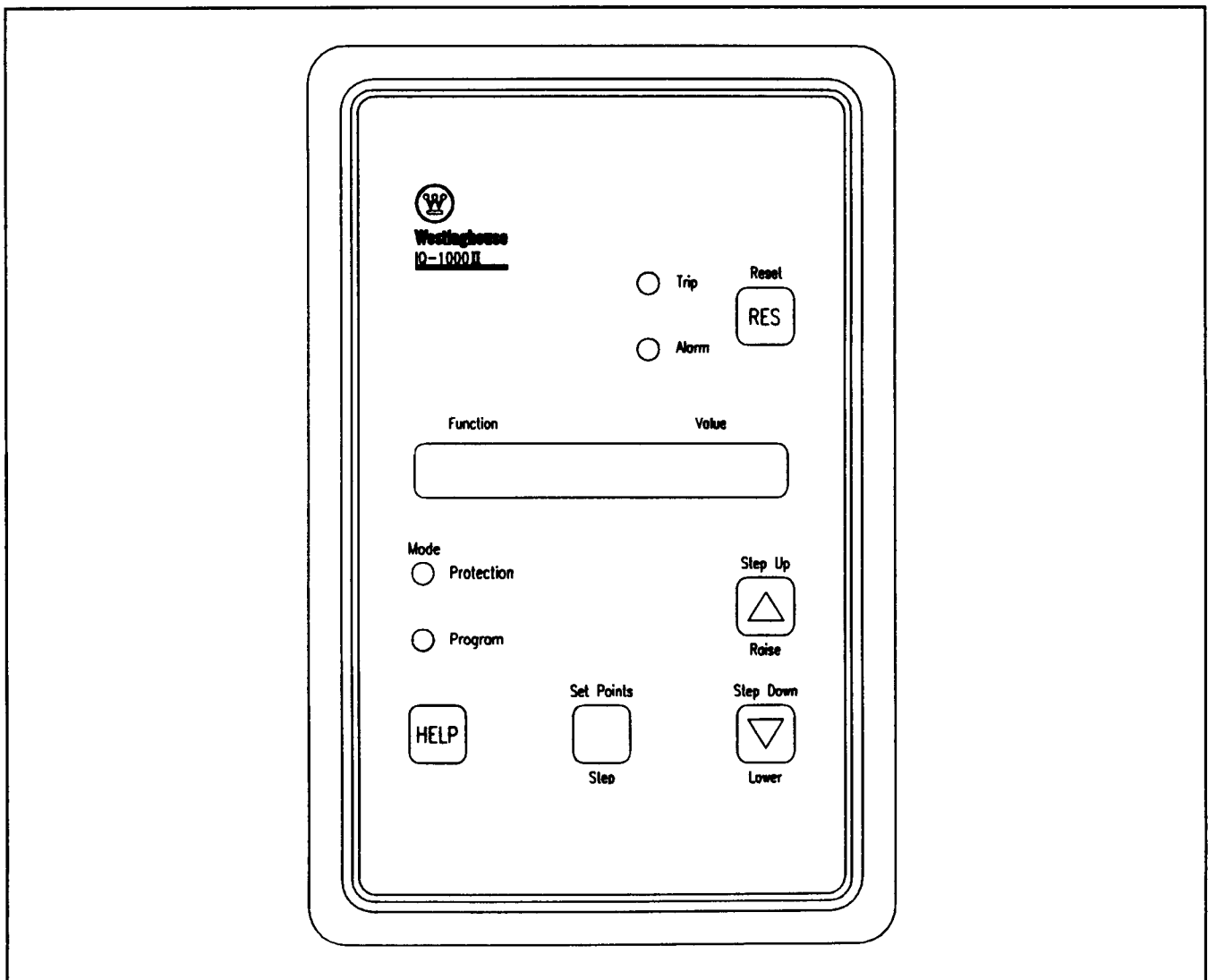

Figure 2.1 — Operator Panel

- Determine the cause of a trip or alarm condition by means of the Display Window. (A description of each trip and alarm condition is given in Section 8.)
- Attempt to reset the unit after a trip or alarm condition has occurred by means of a Reset pushbutton.

The use of the Operator Panel is detailed in Section 4.

**2.1.2 Rear Access Area** — The rear of the IQ-1000 II is normally accessible from the rear of the mounting cabinet's door (see Figure 2.2). All wiring connections to the unit are made on the back of the IQ-1000 II, as follows:

- Terminals 24 and 25 provide a 4-20 mA output signal.
- Terminals 1, 2, and 3 provide access to the Transition Relay's contacts.
- Terminals 4 and 7 receive the incoming AC control voltage.
- Terminal 5 is the chassis ground. A direct connection must be made between terminal 5 and the main ground bus to ensure proper operation.
- Terminal 6 can be jumpered to terminal 9 in order to provide the common (AC neutral) for terminals 8 and 10.

- Terminal 8 is used with the remote trip/reset function. It is the high side of a user-supplied 120 VAC signal input.
- Terminal 9 is the AC neutral, or common, wire associated with terminals 8 and 10.
- Terminal 10 is used with the incomplete sequence report-back function. It is the high side of a user-supplied input signal.
- Terminals 11 thru 23 provide access to the Trip, Auxiliary Trip and Alarm Relays' contacts, as well as the wiring to the RTD Module option. (The Auxiliary Trip Relay is programmable to change state when a specific user-selected trip condition is detected.)
- The fiber optic connector may be used to connect the optional RTD Module to the IQ-1000 II.
- The Communications Port is used with the optional PONI communications card mounted on the back of the IQ-1000 II.
- The CT terminals connect with the three required, user-provided, external current transformers and, if used, an optional user-provided zero sequence ground fault transformer.

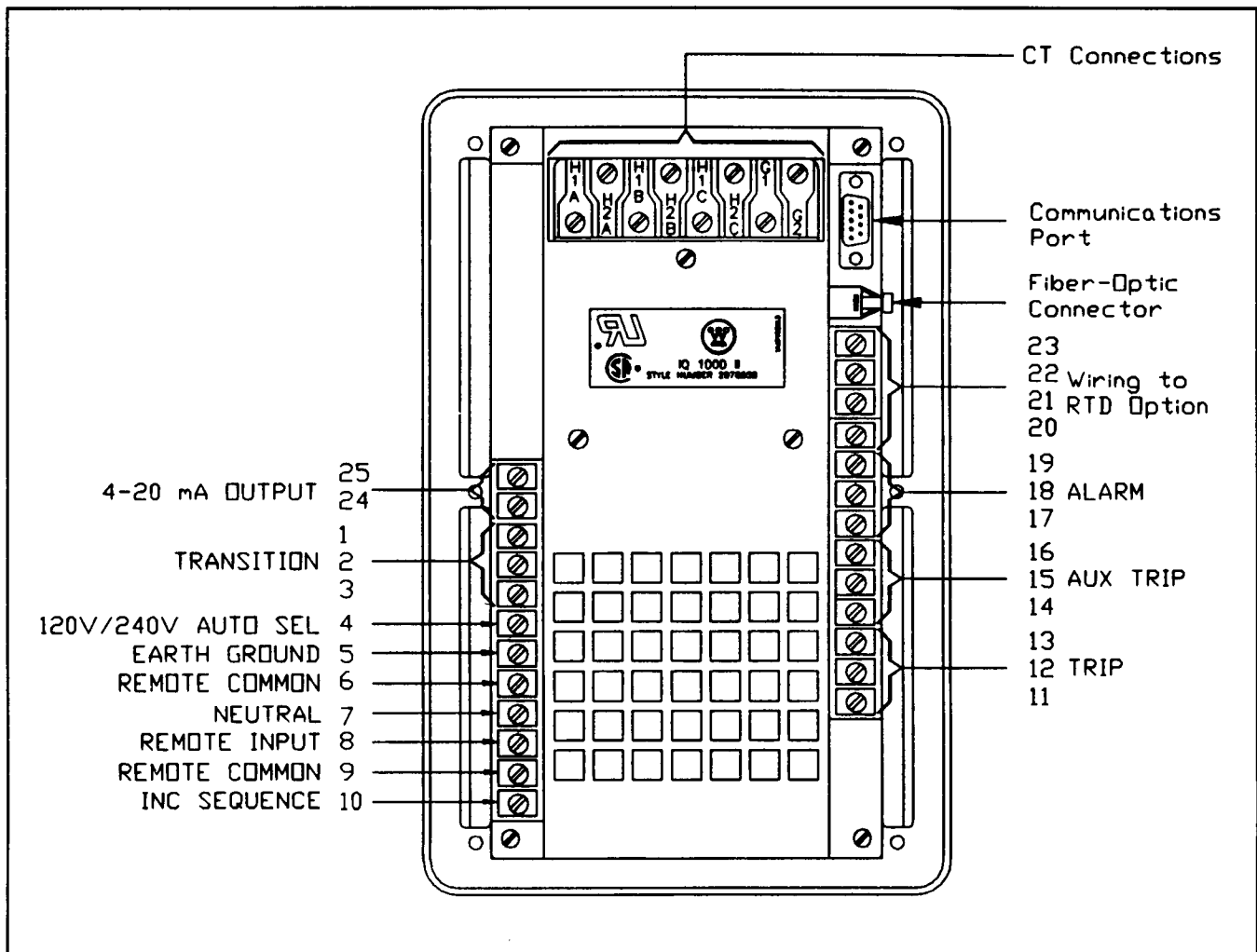

Figure 2.2 — Rear Panel

**2.1.3 Options** — Two options are available with the IQ-1000 II:

- RTD Module Option (Par. 2.1.3.1)
- Communications Option (Par. 2.1.3.2)
- IQ DC Power Supply (Par. 2.1.3.3)

**2.1.3.1 RTD Module Option** — The Universal RTD Module is a separately purchased optional device (see Figure 2.3) which interfaces with the motor RTDs and the IQ-1000 II. The RTD inputs connect to the terminal blocks of the RTD Module as described in Paragraph 5.1.2 and the RTD itself connects to the IQ-1000 II through the fiber optic connector and/or the communications port.

**2.1.3.2 Communications Option** — The Product Operated Network Interface (PONI) is a small printed circuit communications device that is mounted onto the back of the IQ-1000 II and connects the IQ-1000 II to the IMPACC local area network (see Table 1.A). The PONI is a separately purchased option (see Figure 2.4).

**2.1.3.3 IQ DC Power Supply Option** — The IQ DC Power Supply is a separately purchased option that is required only when 40 to 250 VDC is available as a control power source for the IQ-1000 II.

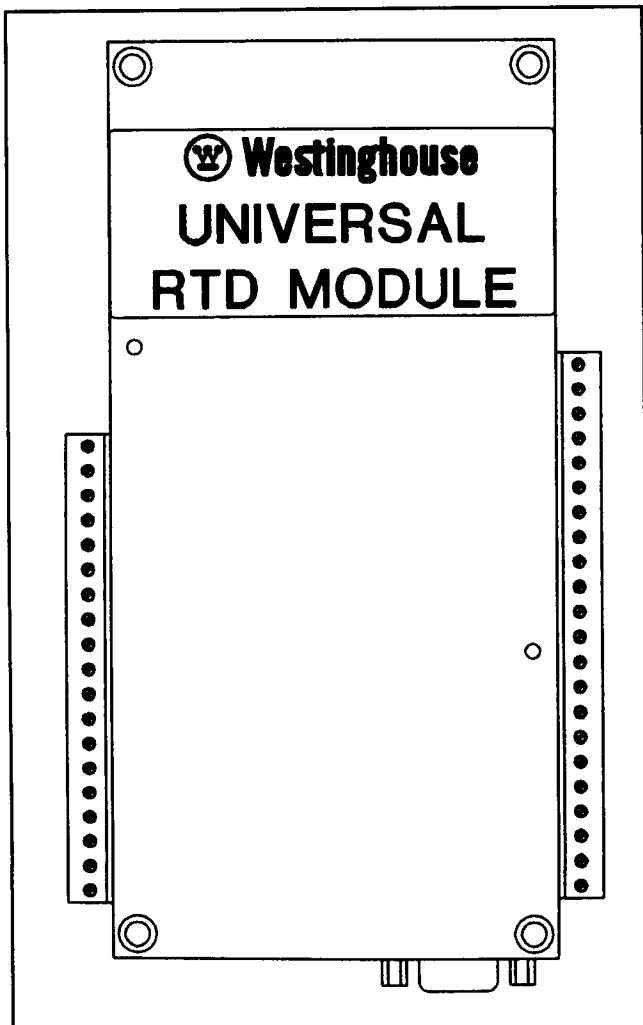

Figure 2.3 — Universal RTD Module

**2.2 Specifications** — The specifications for the IQ-1000 II are listed in Table 2.A.

Table 2.A  
SPECIFICATIONS

<b>Input Supply Requirements:</b>	120 or 240 VAC (+15%, -30%)
<b>Frequency:</b>	50 or 60 Hz (software selectable)
<b>Power</b>	IQ-1000 II = 12 VA RTD Module Option = 6 VA PONI Card = 1 VA
<b>Remote Input Rating:</b>	2.0 VA at 120 VAC
<b>Output Contact Rating:</b>	10 A at 240 VAC Resistive 10 A at 30 VDC Resistive
<b>±4-20 mA Output Rating:</b>	Maximum load resistance = 1 K Ohm
<b>Current Transformer Burden:</b>	0.003 VA
<b>Operating Temperature:</b>	0° to 70°C (32° to 158°F)
<b>Storage Temperature:</b>	-20° to 85°C (-4° to 185°F)
<b>Humidity:</b>	0 to 95% (noncondensing)
<b>IQ-1000 II Dimensions:</b>	Height = 10.25 in. (26.04 cm) Width = 6.72 in. (17.0 cm) Depth = 3.20 in. (8.13 cm) 4.89 in. (12.42 cm) with PONI 5.55 in. (14.10 cm) with RTD Module 6.75 in. (17.15 cm) with RTD Module and PONI
<b>Shipping Weight:</b>	7 lbs (15.4 kg)

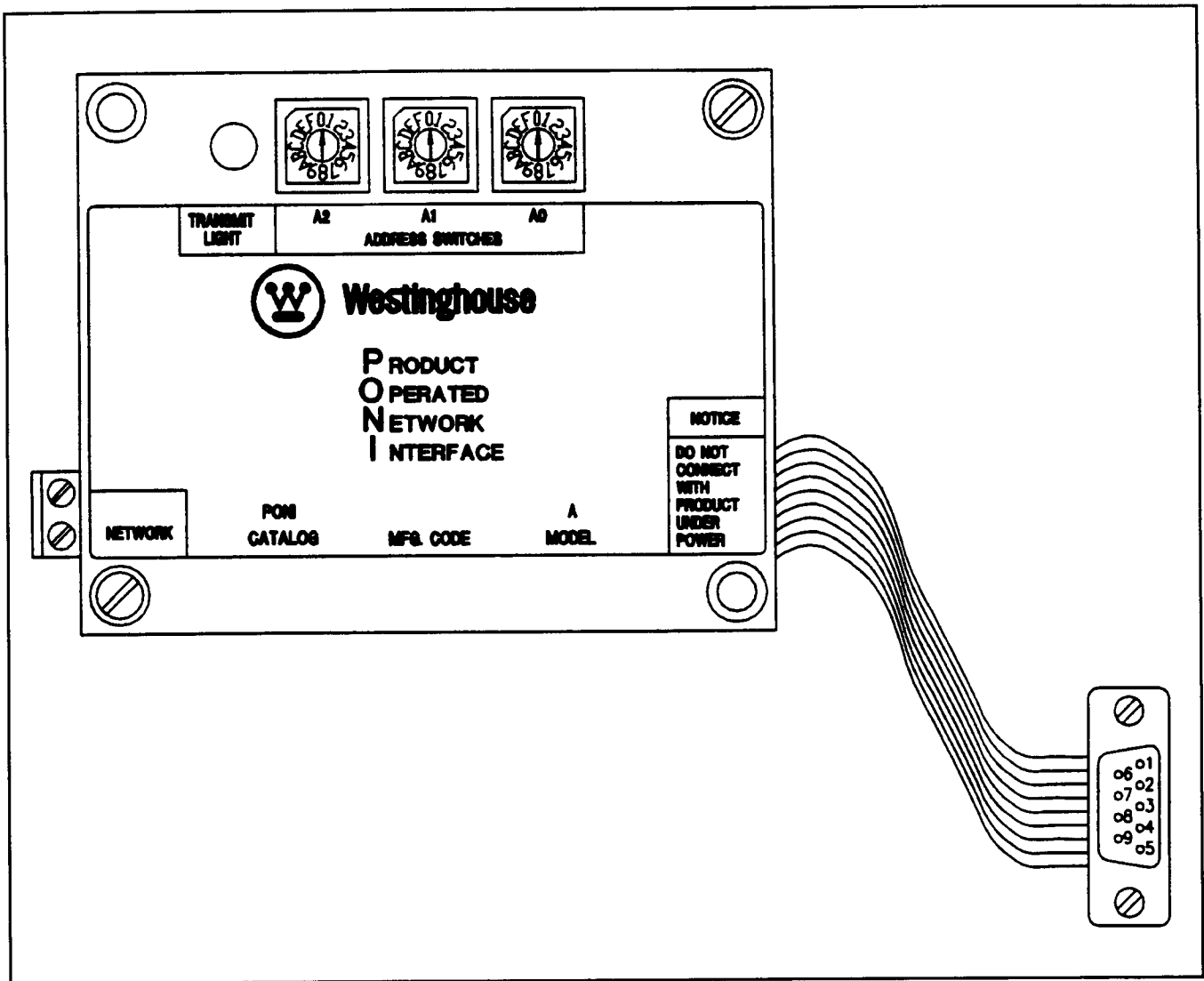

Figure 2.4 — PONI Communications Card Option

## Section 3

## FUNCTIONAL THEORY

**3.0 General** — This section describes how the IQ-1000 II's hardware and software function together to control, monitor, and protect the motor.

The explanations are divided into the following areas:

- Sensing inputs (Par. 3.1)
- Protective functions (Par. 3.2)
- Metering functions (Par. 3.3)

**3.1 Sensing Inputs** — The IQ-1000 II receives motor current sensing derived from 3 separate current transformers, each of which monitors one phase of an AC line to the motor (see Figure 3-1). If an optional zero sequence ground fault transformer is used, the IQ-1000 II monitors ground fault current levels and compares them to a user-selected setpoint. If optional RTDs are used, the IQ-1000 II gathers winding temperature data from six RTDs embedded in the stator windings of the motor. Four RTDs associated with the motor bearings and load bearings can also be monitored for tempera-

ture levels. Additionally, one auxiliary RTD, such as motor case temperature, can be monitored.

**3.2 Protective Functions** — Protective functions monitor motor operating conditions (such as current and temperature) in an ongoing manner. When these exceed user-selected levels, an alarm condition is initiated, and then, if necessary, a trip condition occurs. These two conditions have the following functions:

- An alarm condition energizes the IQ-1000 II's internal Alarm Relay.
- A trip condition — other than AC line loss — removes power from the motor by either energizing or de-energizing the Trip Relay. This relay is used for protective control and reporting purposes within the application.
- An auxiliary trip condition — other than AC line loss — either energizes or de-energizes the Auxiliary Trip Relay. An auxiliary trip condition, programmed by the user, occurs on one of the following trip conditions:

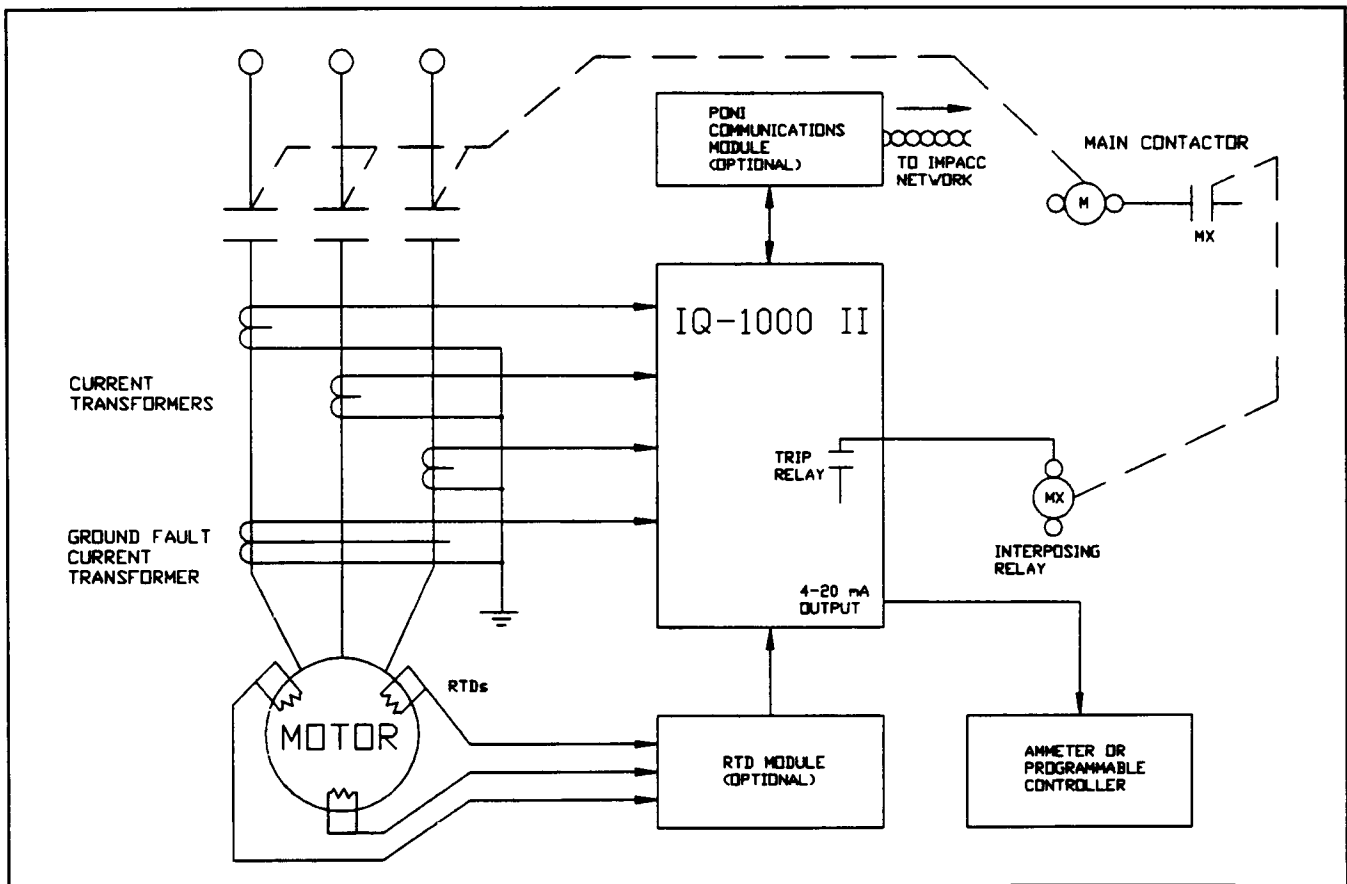

Figure 3.1 — System Overview (Simplified)

- Any trip condition
- Instantaneous overcurrent
- I<sup>2</sup>T
- Ground fault
- Jam
- Underload
- Motor bearing temperature
- Load bearing temperature
- Winding temperature
- Phase reversal

The Auxiliary Trip Relay can be wired to perform either trip (removing power from the motor) or trip indication features.

- When a trip condition occurs, the IQ-1000 II stores metering functions such as motor current levels, temperatures, etc. This "picture" is maintained for use by maintenance personnel and is stored until a Reset is performed.

The IQ-1000 II maintains the metering data stored just prior to a trip condition indefinitely, provided that a reset from the Reset pushbutton, remote input or IMPACC is not received.

The IQ-1000 II's fault monitoring can be divided into the following types:

- Load-associated protection (Par. 3.2.1)
- Rotor temperature protection (Par. 3.2.2)

**3.2.1 Load-Associated Protection** — The monitored level of actual motor current is used to determine when the instantaneous overcurrent trip, jam trip, and underload trip setpoints have been reached. Actual temperature feedback from the load bearing RTDs are compared with the load bearing temperature setpoint. If necessary, alarm and/or trip conditions are initiated. (Refer to Table 8.B for a complete listing of these functions.)

**3.2.2 Rotor Temperature Protection** — Each design of motor has a specific damage curve. Usually it is called the I<sup>2</sup>T curve

(current squared multiplied by time). In AC motors, the current balance between phases is of major concern due to the additional heating associated with an unbalanced phase condition. Current unbalance is mainly caused by voltage unbalance, the result of single-phase loads on a 3-phase system, and/or motor winding unbalance.

With larger horsepower motors, the design is usually rotor-limited. It therefore becomes important to determine the total heating effect on the rotor. For analysis, the motor can be considered to have two rotors (see Figure 3.2). One is the effect resulting from balanced current. The other is the effect of unbalanced current. If perfect current balance existed in each phase of the motor current, then I<sub>1</sub> would be the line current squared with no error in the heating projected from this current. This positive component of current generates the motor output torque or work.

The second component of the current is the negative sequence, represented as I<sub>2</sub>. It is a 3-phase current with a reverse phase rotation from that of the AC source. This current generates countertorque to the motor output torque, or negative work. Because the torque generated by I<sub>2</sub> does not leave the rotor, it is absorbed as heat and therefore has a more significant effect on the rotor heating than the I<sub>1</sub>. Any 3 phase AC current can be represented by the addition of I<sub>1</sub> plus I<sub>2</sub>. Using vector analysis to determine the positive sequence, one rotates phase B in the positive direction 120 degrees and phase C in the positive direction 240 degrees. (Refer to Figures 3.3 and 3.4.) The formula for I<sub>1</sub> is:

$$I_1 = \frac{I_A + (I_B + 120) + (I_C + 240)}{3}$$

The negative sequence is determined by rotating phase B in the opposite, or negative, direction for 120 degrees and phase C rotated in the negative direction for 240 degrees. (Refer to Figure 3.5.) The formula for I<sub>2</sub> becomes:

$$I_2 = \frac{I_A + (I_B - 120) + (I_C - 240)}{3}$$

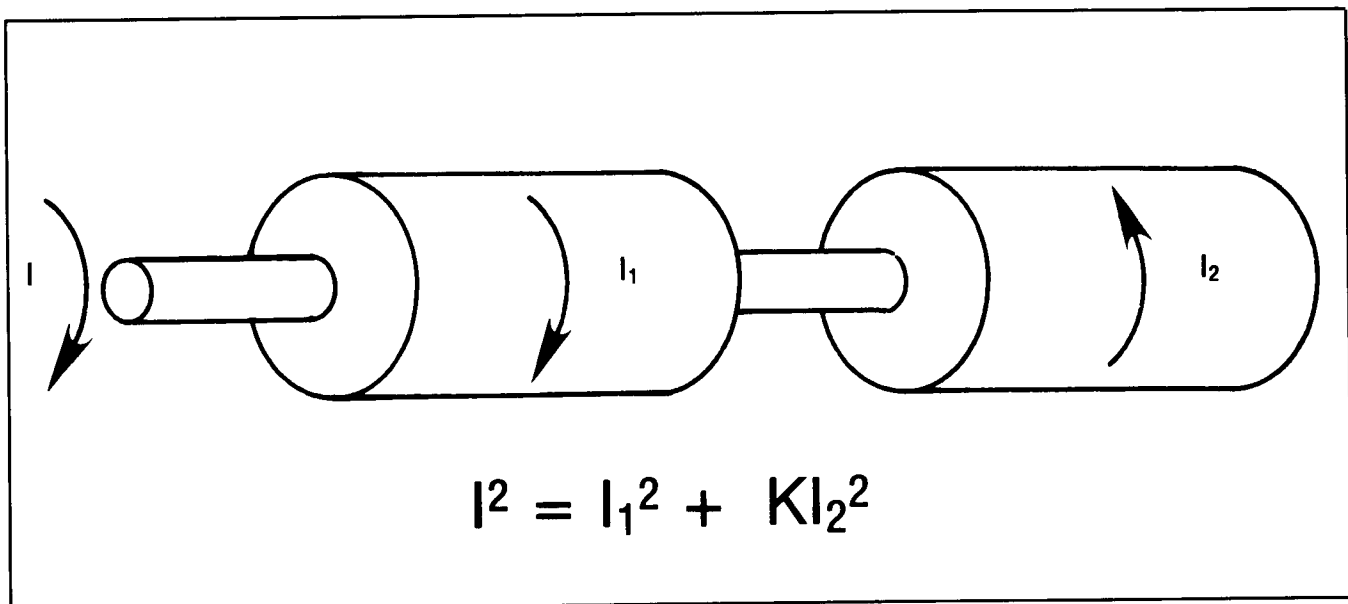

Figure 3.2 — Positive and Negative Sequence Current Components

Prior to the use of a microprocessor in a motor protection system, there was no practical way of determining the total heating effect of the positive and negative sequence on a continuous basis. Therefore, less than adequate assumptions had to be made. This resulted in nuisance tripping and actual, or near-actual, motor burnouts. The IQ-1000 II microprocessor uses a unique, patented system for determining these values.

It is not necessary to pick an arbitrary phase unbalance set point to trip the motor. As long as the combined effect of the positive and negative sequence currents does not approach the motor damage curve, the IQ-1000 II will allow the motor to operate.

**3.3 Metering Functions** — The IQ-1000 II calculates and displays the accumulated values obtained by monitoring characteristics such as motor current level, RTD temperature levels, etc. (Section 8 describes the monitoring capabilities of the IQ-1000 II in detail.)

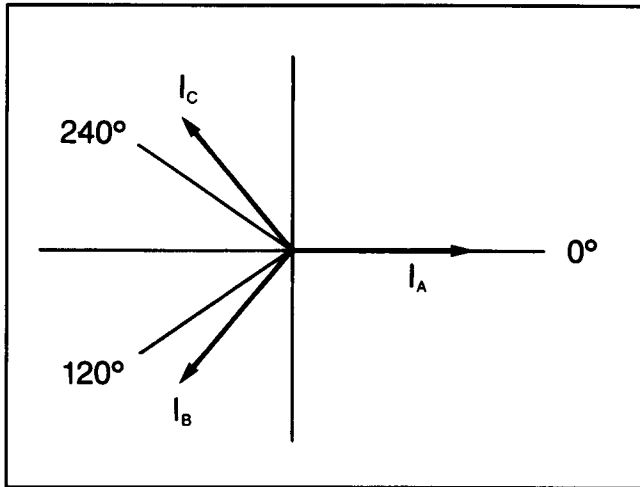

Figure 3.3 — Symmetrical Components

The current squared, as used in the calculation for rotor heat, is:

$$I^2 = I_1^2 + KI_2^2$$

Here  $I_2^2$  is weighted by K because of the disproportional heating caused by the negative sequence

With the use of a microprocessor, the effects of both the positive and negative sequence currents are accurately taken into account. Their **combined** effect is incorporated into a "rotor protection algorithm." The algorithm effectively keeps track of the temperature of the rotor.

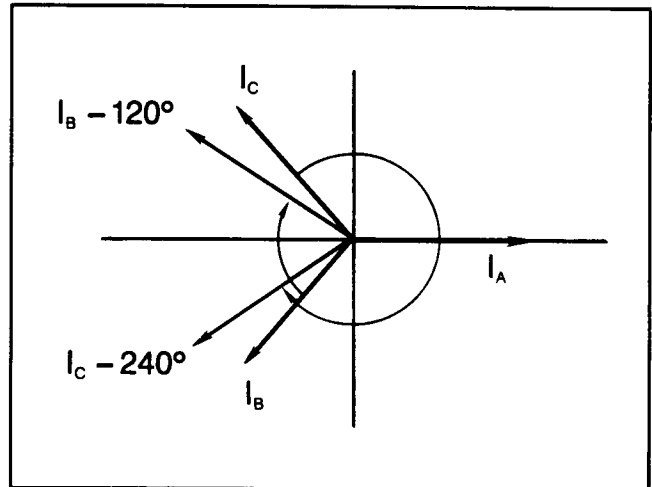

Figure 3.5 — Negative Sequence Currents

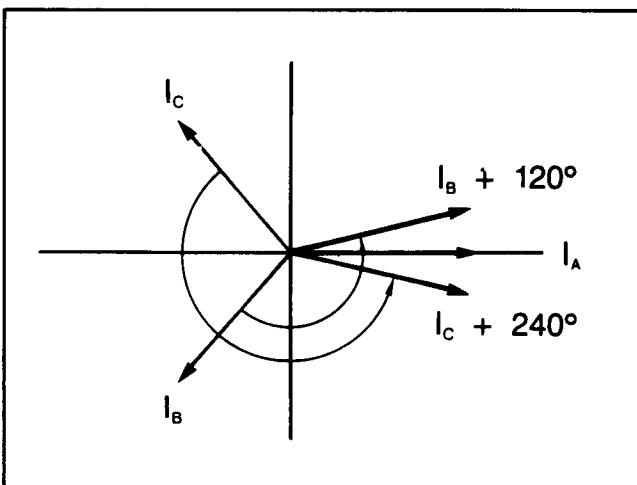

Figure 3.4 — Positive Sequence Currents

Section 4

# OPERATOR PANEL

**4.0 Introduction** — This section describes the IQ-1000 II's Operator Panel and details its major components. Each component's function is described and the procedures for setpoint entry, modification and examining monitored motor parameters is detailed. The section is divided into the following areas:

- General description
- Component descriptions
- Entering setpoint values

- Reviewing IQ-1000 II setpoints
- Monitoring metered values

**4.1 General Description** — The IQ-1000 II's faceplate is a plastic and polyester material designed to withstand a variety of harsh industrial environments. All indicators, displays and pushbuttons are located on the faceplate (see Figure 4.1). White colored lettering relates to the Protection mode and blue colored lettering relates to the Program mode. A keyswitch, which switches the IQ-1000 II between the Program and

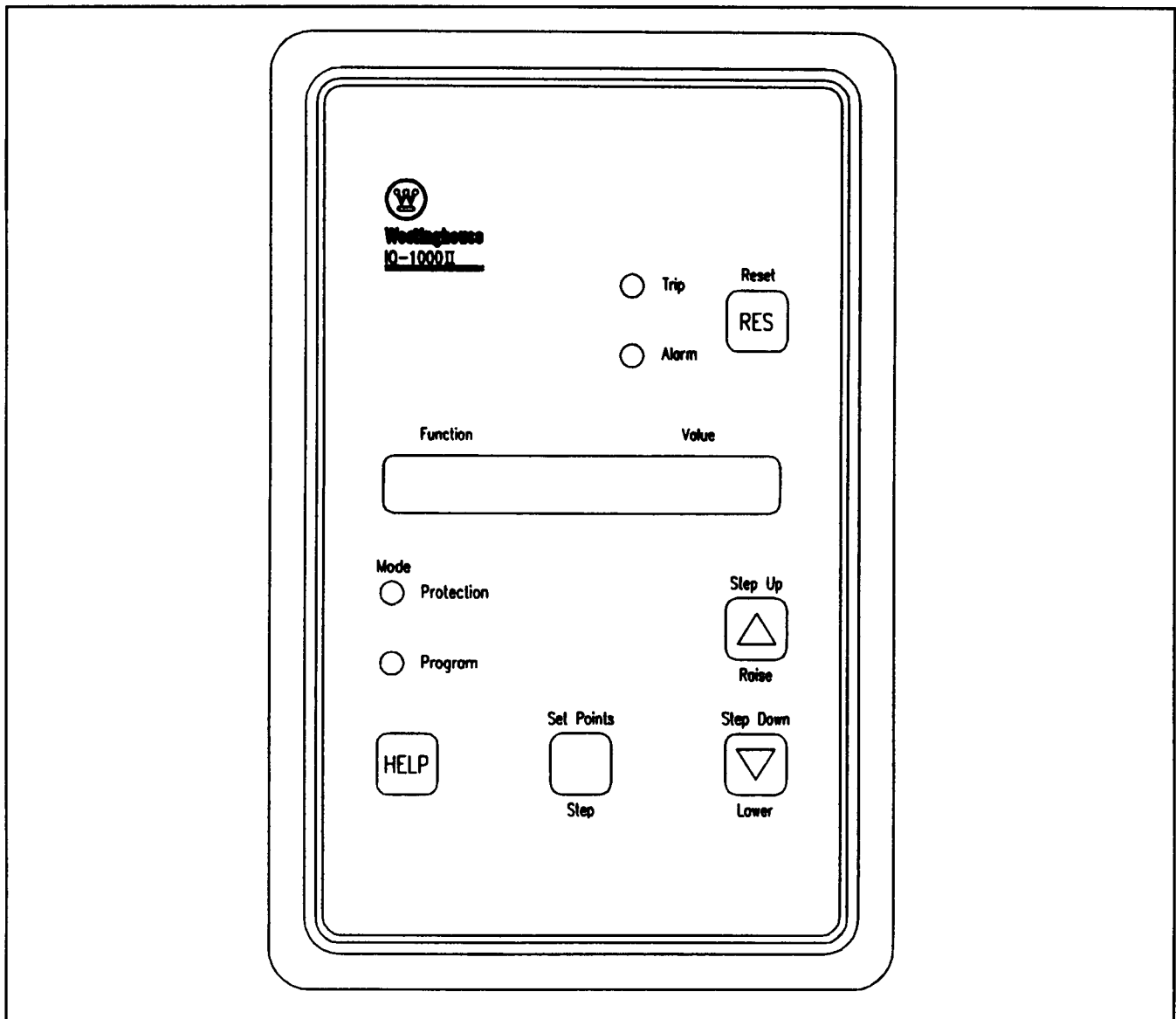

Figure 4.1 — IQ-1000 II Operator Panel

Protection modes, is located on the right side of the unit's chassis as it is viewed from the rear (see Figure 4.2).

**4.2 Component Descriptions** — This paragraph and its subparagraphs provide a description of the IQ-1000 II's display window, keyswitch, pushbuttons and LED indicators.

**4.2.1 Display Window** — The display window consists of eight alphanumeric illuminated characters which indicate the following information and data:

- Setpoints and values
- Metered data from the monitored motor or equipment
- Alarm condition information
- Pre-trip data
- Trip condition data
- Scrolling "Help" messages.

The display window shows the Function name or abbreviation on the left side of the display, with the Value information on the right side.

**4.2.2 Keyswitch** — The Program/Protection keyswitch allows the user to select either the Program mode or the Protection operating mode for the IQ-1000 II. The key for the keyswitch is removable, providing security against unauthorized modification of setpoints.

**NOTE**

The key can be removed only when the switch is in the Protection mode.

**4.2.2.1 Program Mode** — When the keyswitch is in the Program position, the controlled motor cannot be started if setpoint 51 is set to STOP PGM (all units are shipped from the factory with setpoint 51 set to the default, STOP PGM). With setpoint 51 set to STOP PGM, the controlled motor must first be stopped in order to enter the Program mode. Placing the keyswitch to the Program position will not initiate the Program mode if the motor is running.

When the keyswitch is in the Program position, the motor can be started and/or run if setpoint 51 is set to RUN PGM. This allows the IQ-1000 II user to program the unit without interrupting a manufacturing process.

**CAUTION**

If setpoint 51 is set to RUN PGM and the motor is running while setpoints are being entered, all IQ-1000 II motor protection features are disabled and the motor is unprotected until the unit's keyswitch is returned to the Protection position.

**4.2.2.2 Protection Mode** — When the keyswitch is in the Protection position, the controlled motor can be started or stopped and is allowed to run normally, as defined by the setpoint values programmed into the IQ-1000 II. In the Protection mode, the IQ-1000 II monitors motor parameters and provides protective functions for the controlled motor.

Individual setpoints may be examined in the Protection mode, but they may not be modified.

**4.2.3 Set Points/Step Pushbutton** — The Set Points (white lettering)/Step (blue lettering) pushbutton function varies according to the IQ-1000 II's operating mode (determined by the position of the keyswitch).

In the Program mode, pressing the Step (blue lettering) pushbutton repeatedly will cycle through the Program menu in the forward direction. To cycle through the Program menu in the reverse direction, press and hold the Step pushbutton while repeatedly pressing the Lower (down arrow) pushbutton. While in the Program mode, the Program LED is continuously lit.

In the Protection mode, pressing the Set Points (white lettering) pushbutton causes the display window to display the software version installed in the IQ-1000 II. If the user desires to review the programmed setpoint values, pressing either the up or down arrow key causes the setpoints to be displayed sequentially.

If the Set Points pushbutton is pressed again, the display window will show the message PRE-TRIP. Pre-trip refers to

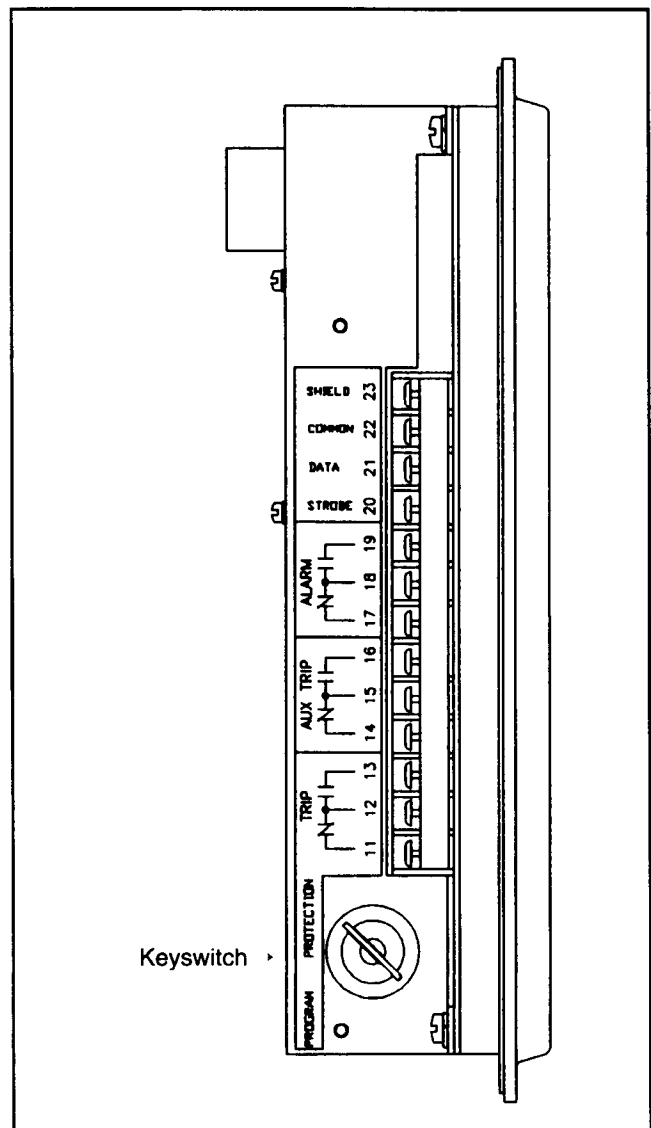

Figure 4.2 — Side View Showing Keyswitch

the monitored motor parameters that were present the instant before the last trip condition occurred. The pre-trip values are displayed by pressing either the up or down arrow keys. While the pre-trip information is displayed, the Protection LED remains lit and the Trip LED blinks as a reminder that the information being displayed pertains to a pre-trip state.

Pressing the Set Points pushbutton again will return the display to the system READY/RUN message that is first displayed upon entering the Protection mode.

#### 4.2.4 Step Up/Raise, Step Down/Lower Pushbuttons —

The Step Up/Raise and the Step Down/Lower each have two separate functions corresponding to their lettering color. An explanation of their functions follows.

In the Protection mode with the system READY/RUN message displayed, the Step Up and Step Down pushbuttons (white lettering) scroll through run-monitor data. This data contains information such as phase current, operations count, trip counts, etc. (see Table 9.B for a complete listing of run-monitor data).

If the software version message is displayed, the Step Up and Step Down pushbuttons scroll through the setpoint values programmed in the IQ-1000 II.

In the Program mode, the Raise and Lower pushbuttons (blue lettering) respectively increment and decrement a selected setpoint value.

**4.2.5 Help Pushbutton** — Pressing the Help pushbutton provides a scrolling description of the displayed message, including units of measure, for any of the IQ-1000 II's messages. The Help message may be terminated by pressing the Reset pushbutton while the Help message is displayed.

**4.2.6 Reset Pushbutton** — The Reset pushbutton is primarily used to reset the IQ-1000 II after a trip condition has occurred, assuming that the cause of the trip has been corrected.

In the Program mode, pressing the Reset pushbutton will display the first item in the program menu.

In the Protection mode, pressing the Reset pushbutton will clear a trip condition if the underlying cause of the trip condition has been corrected. If the Reset pushbutton is pressed and there is no trip condition present, the display window will display the status of the motor (first item of the run-monitor table, Table 9.B).

**4.2.7 Protection, Program, Alarm and Trip LEDs** — The IQ-1000 II has four status indicator LEDs—Protection, Program, Alarm and Trip.

The Protection LED is lit when the keyswitch is in the Protection position.

The Program LED is lit when the keyswitch is in the Program position. Additionally, the Program LED blinks continuously when the keyswitch is in the Protection position and the Set Points/Step pushbuttons are pressed to review programmed setpoints (see Par. 4.2.3). The blinking Program LED indicates that the program menu, not protection-monitor data, is being displayed.

The Alarm LED is lit when an alarm setpoint value has been equalled or exceeded.

The Trip LED is lit when a trip condition has occurred. Additionally, the Trip LED blinks continuously when the keyswitch is in the Protection position and the Set Points/Step pushbuttons are pressed to review pre-trip data (see Par. 4.3.2). The blinking Trip LED indicates that pre-trip data is being displayed and that a trip condition is not present.

**4.3 Entering Setpoint Values** — Setpoint values may be entered or modified only when the IQ-1000 II is in the Program mode. The following procedure details how to enter or modify setpoints, assuming that actual setpoints for a specific application are available on the Set Point Record Sheet (see Par. 8.0 and Table 8.B).

**Step 1** — If the associated motor is running and the keyswitch is in the Protection position, press the Set Points pushbutton until the software version message is displayed. Press the Step Down pushbutton twice. The display window will display either STOP PGM or RUN PGM. If STOP PGM is displayed, the associated motor must be stopped before attempting to enter or modify setpoint values. If RUN PGM is displayed, setpoint values may be entered or modified while the motor is running.

#### CAUTION

If setpoint 51 is set to RUN PGM and the motor is running while setpoints are being entered, all IQ-1000 II motor protection features are DISABLED and the motor is unprotected until the unit's keyswitch is returned to the Protection position.

**Step 2** — Place the Program/Protection keyswitch to the Program position. The display window will display the software version message and the Program LED will be continuously lit. The Protection LED will extinguish if the unit is in the STOP PGM mode. If the unit is in the RUN PGM mode, the Protection LED will blink continuously.

**Step 3** — Press the Step pushbutton to display menu item 1 or the setpoint to be modified. The display window will display the setpoint name and some value (represented by an X in the Set Point Record Sheet, Table 8.B). Increase or decrease the setpoint value by pressing the Raise or Lower pushbuttons. Values change at the approximate rate of 2 increments per second. After the Raise or Lower pushbuttons has been held continuously for a count of 10 changes, the rate of change increases to 20 increments per second. Setpoint values wrap from maximum to minimum or vice versa to prevent the user from going out of the usable range.

**Step 4** — When the setpoint value is correctly set, press the Step pushbutton to move to the next setpoint.

**Step 5** — Once all setpoints have been entered correctly according to the Set Point Record Sheet, turn the keyswitch to the Protection position. The Protection LED will light and the Program LED will extinguish. The IQ-1000 II is now fully functional and ready to monitor and protect its associated motor.

**4.4 Reviewing IQ-1000 II Setpoints** — Once all setpoints have been entered, they may be verified while the unit is in the Protection mode. To review programmed setpoints, ensure the keyswitch is in the Protection position and press the Set

Points pushbutton until the software version message is displayed. Programmed setpoints may be reviewed by stepping up or down through the setpoints by using the Step Up or Step Down pushbuttons. If the setpoint messages are not clear, press the Help pushbutton for an unabbreviated explanation of the setpoint name and unit of measurement.

**4.5 Monitoring Metered Values** — The IQ-1000 II allows the user to monitor the actual operating values of various metered functions (see Table 4.A).

**Step 1** — Place the keyswitch in the Protection position (the motor can be either running or stopped). If system message READY/RUN is not displayed, press the Set Points pushbutton until one or the other message is displayed.

**Step 2** — Press either the Step Up or Step Down pushbutton to display individual metered values.

Values appear in an abbreviated format.

**Table 4.A**  
**PROTECTION-MONITOR MENU**

Item No.	Display	Complete "Help" Description	Resolution
0	(Status of Motor) READY--X/START/RUN	READY TO START MOTOR -- READY -- 1 FOR SINGLE PHASE MODE -- READY -- 3 FOR THREE PHASE MODE/ATTEMPTING TO START MOTOR/MOTOR IS RUNNING	—
1	I <sub>A</sub> XXX	PHASE A CURRENT IN AMPS	1 amp
2	I <sub>B</sub> XXX	PHASE B CURRENT IN AMPS	1 amp
3	I <sub>C</sub> XXX	PHASE C CURRENT IN AMPS	1 amp
4	I <sub>G</sub> XX	GROUND FAULT CURRENT IN AMPS	1 amp
5	% I <sub>A</sub> XXX	PERCENT FULL LOAD CURRENT PHASE A	1%
6	% I <sub>B</sub> XXX	PERCENT FULL LOAD CURRENT PHASE B	1%
7	% I <sub>C</sub> XXX	PERCENT FULL LOAD CURRENT PHASE C	1%
8	WT1 XXX	WINDING TEMP 1 IN DEGREES	1° C
9	WT2 XXX	WINDING TEMP 2 IN DEGREES	1° C
10	WT3 XXX	WINDING TEMP 3 IN DEGREES	1° C
11	WT4 XXX	WINDING TEMP 4 IN DEGREES	1° C
12	WT5 XXX	WINDING TEMP 5 IN DEGREES	1° C
13	WT6 XXX	WINDING TEMP 6 IN DEGREES	1° C
14	MBT1 XXX	MOTOR BEARING TEMP 1 IN DEGREES	1° C
15	MBT2 XXX	MOTOR BEARING TEMP 2 IN DEGREES	1° C
16	LBT1 XXX	LOAD BEARING TEMP 1 IN DEGREES	1° C
17	LBT2 XXX	LOAD BEARING TEMP 2 IN DEGREES	1° C
18	AUXT XXX	AUXILIARY TEMP IN DEGREES	1° C
19	OCNT XX	OPERATION COUNT	1 count
20	RT X	RUN TIME IN HOURS	1 hr.
21	RMST XX	REMAINING STARTS	1 start
22	OST XXX	TIME LEFT ON OLDEST START IN MINUTES	1 min.
23	IMX XXXX	HIGHEST PHASE CURRENT SINCE LAST RESET	1 amp
24	WTMX XXX	HIGHEST WINDING TEMP SINCE LAST RESET	1° C
25	I <sup>2</sup> T XX	NUMBER OF I <sup>2</sup> T TRIPS SINCE LAST RESET	1 trip
26	IOC XX	NUMBER OF IOC TRIPS SINCE LAST RESET	1 trip
27	UL XX	NUMBER OF UL TRIPS SINCE LAST RESET	1 trip
28	JAM XX	NUMBER OF JAM TRIPS SINCE LAST RESET	1 trip
29	GF XX	NUMBER OF GF TRIPS SINCE LAST RESET	1 trip
30	RTD XX	NUMBER OF RTD TRIPS SINCE LAST RESET	1 trip
31	ICM XXX	ADDRESS ON THE IMPACC NETWORK	1 (hex)
32	%I <sup>2</sup> T XXX	PERCENT OF I <sup>2</sup> T TRIP LEVEL	1%

 Not displayed if RTD Module is not connected

Section 5

INSTALLATION

**5.0 General** — This section describes general mounting, wiring, and wire routing procedures to be followed by the electrical installation crew when installing the IQ-1000 II. The information listed here builds on earlier sections in this manual.

**5.1 Mounting** — The following subparagraphs describe the mounting of both the IQ-1000 II and the RTD and communication options.

**5.1.1 IQ-1000 II** — The IQ-1000 II is a self-contained unit which is intended to be mounted through a cutout in a panel or

enclosure door. The dimensions for this cutout, along with the location of six required mounting holes, are shown in Figure 5.1. Before actually cutting the metal panel, be sure that the required three-dimensional clearances for the IQ-1000 II chassis allow mounting in the desired location. (Clearances are shown in Figure 5.2 and Figure 5.3).

Cutout tolerances and mounting screw hole placement are critical. In particular, the horizontal dimension between the center of the mounting holes and the cutout's vertical edge must be within 0 and +0.050 in. (0.13 cm).

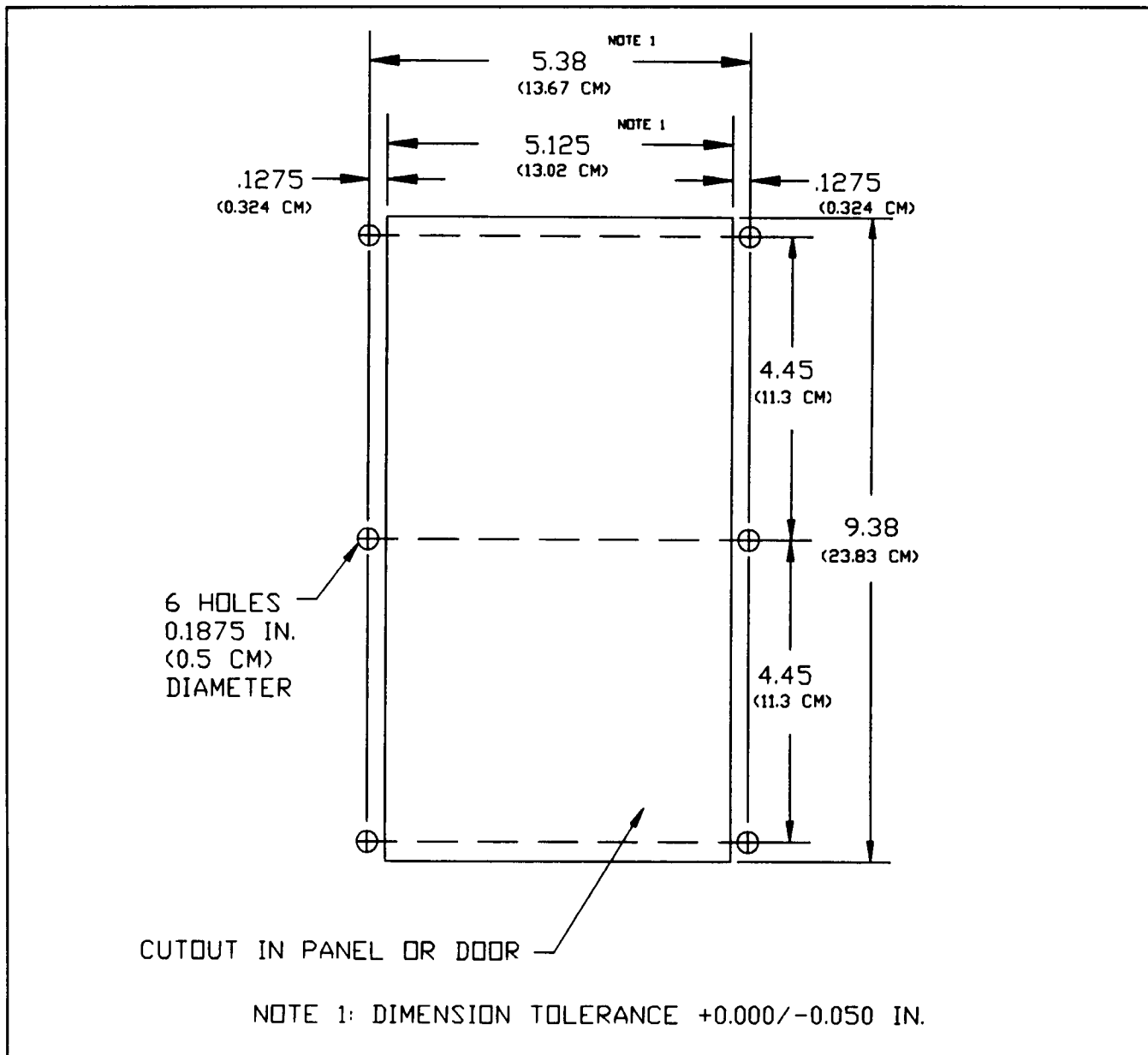

Figure 5.1 — IQ-1000 II Chassis Cutout Dimensions

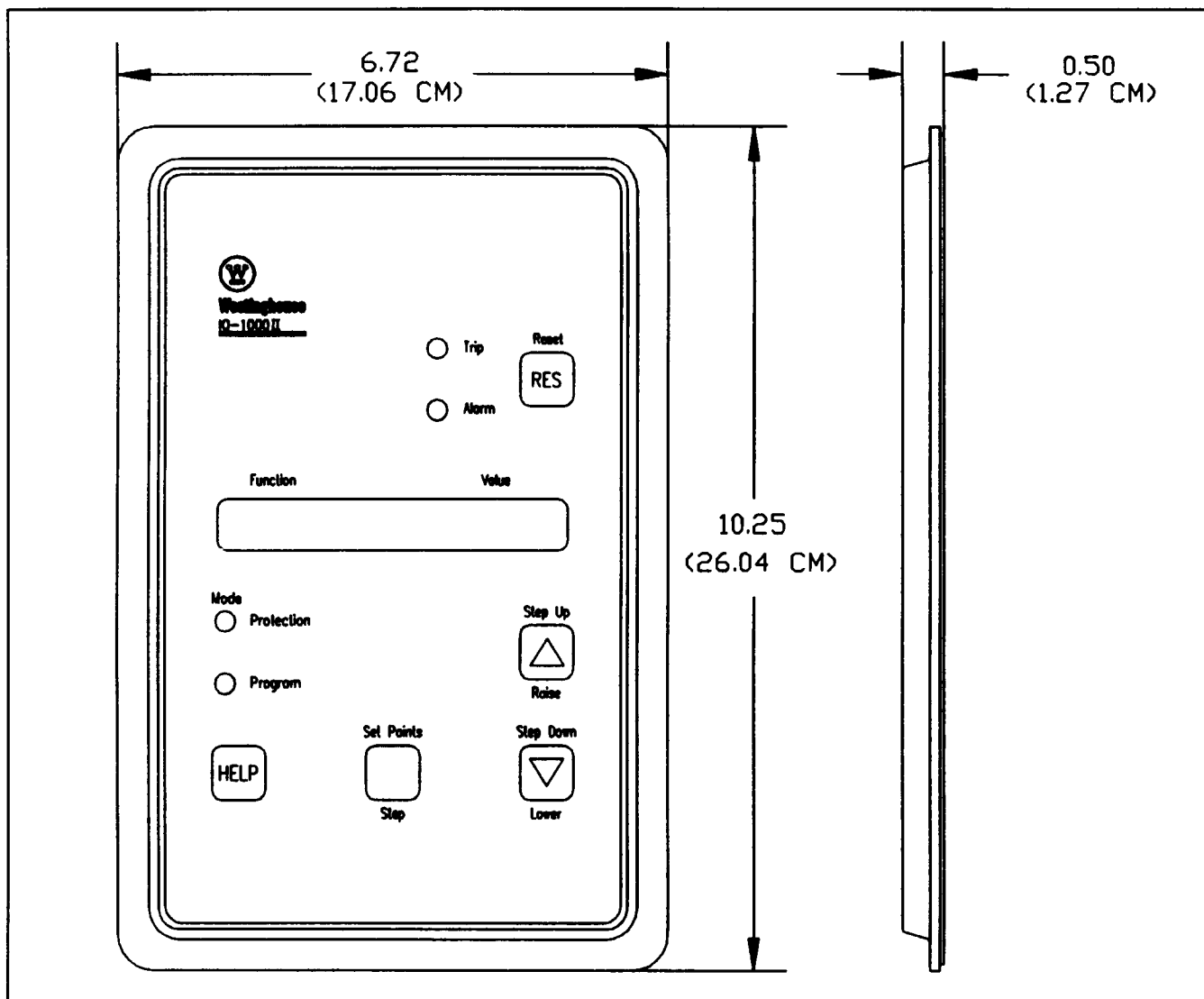

Figure 5.2 — IQ-1000 II Faceplate Dimensions

**NOTE**

Do not use a tap on the faceplate of the IQ-1000 II since this will remove excessive plastic from the holes, resulting in less threaded material to secure the IQ-1000 II to its mounting panel.

Place the IQ-1000 II through the cutout in the enclosure from the front, with the Operator Panel facing outward. Use 0.375 in. (0.75 cm) long screws (included with the IQ-1000 II) to mount the unit on a single-thickness metal panel.

**5.1.2 RTD Option** — The RTD option consists of a stand-alone enclosure containing the RTD Module. The Universal RTD Module can be connected to the IQ-1000 II via 3-conductor shielded cable and/or a fiber optic link.

The RTD Module may be mounted either on the back of the IQ-1000 II by using the RTD mounting bracket (supplied with the RTD Module) or mounted remotely from the unit. If the installation requires mounting the RTD Module to the IQ-1000 II, see Figure 5.3 for overall depth clearance requirements.

If mounting the RTD Module remotely from the IQ-1000 II, see Figures 5.4 and 5.5. Figure 5.4 shows the RTD Module chassis dimensions and Figure 5.5 is the mounting screw hole template pattern.

Observe Figure 5.6 which shows the RTD terminal connections, and note the following:

- Wiring for the RTDs is connected to the RTD Module at terminals 1-35.
- The incoming 120 VAC supply line for the RTD Module is wired to J3.
- Wiring between the IQ-1000 II and the RTD Module is connected using 3-conductor shielded cable at terminals 20, 21 and 22 of the IQ-1000 II and at J2 of the RTD board, **and/or** using a fiber optic cable between the fiber optic connectors on the IQ-1000 II and the RTD Module.
- When using 3-conductor shielded cable to connect the IQ-1000 II and RTD Module, the shield should be connected **only** to terminal 23 of the IQ-1000 II.

- A Communications option (PONI card) can be connected to the RTD Module for communications of temperature-only information over an IMPACC network. Mounting and clearance information is contained in a separate Instruction Leaflet, IL 17361.

(which runs between the RTD chassis and IQ-1000 II) should not exceed 500 ft. (152 m).

If using a fiber optic link, the user-provided link (which runs between the RTD chassis and IQ-1000 II) should not exceed 400 ft. (122 m).

**NOTE**

The IQ-1000 II and Universal RTD Module can be linked using both three conductor shielded cable and fiber optics. When this configuration is used, the temperature information will be transmitted via the fiber optic link. The 3-conductor shielded cable will transmit this information only if the fiber optic link fails.

**NOTE**

The fiber optic cable must be connected between the IQ-1000 II and the Universal RTD Module prior to power-up to ensure normal communications.

If communications between the IQ-1000 II and the RTD Module were operating normally and communications are then lost between the units, press the Reset pushbutton on the IQ-1000 II Operator Panel to restore communications.

If using 3-conductor shielded cable, the user-provided cable

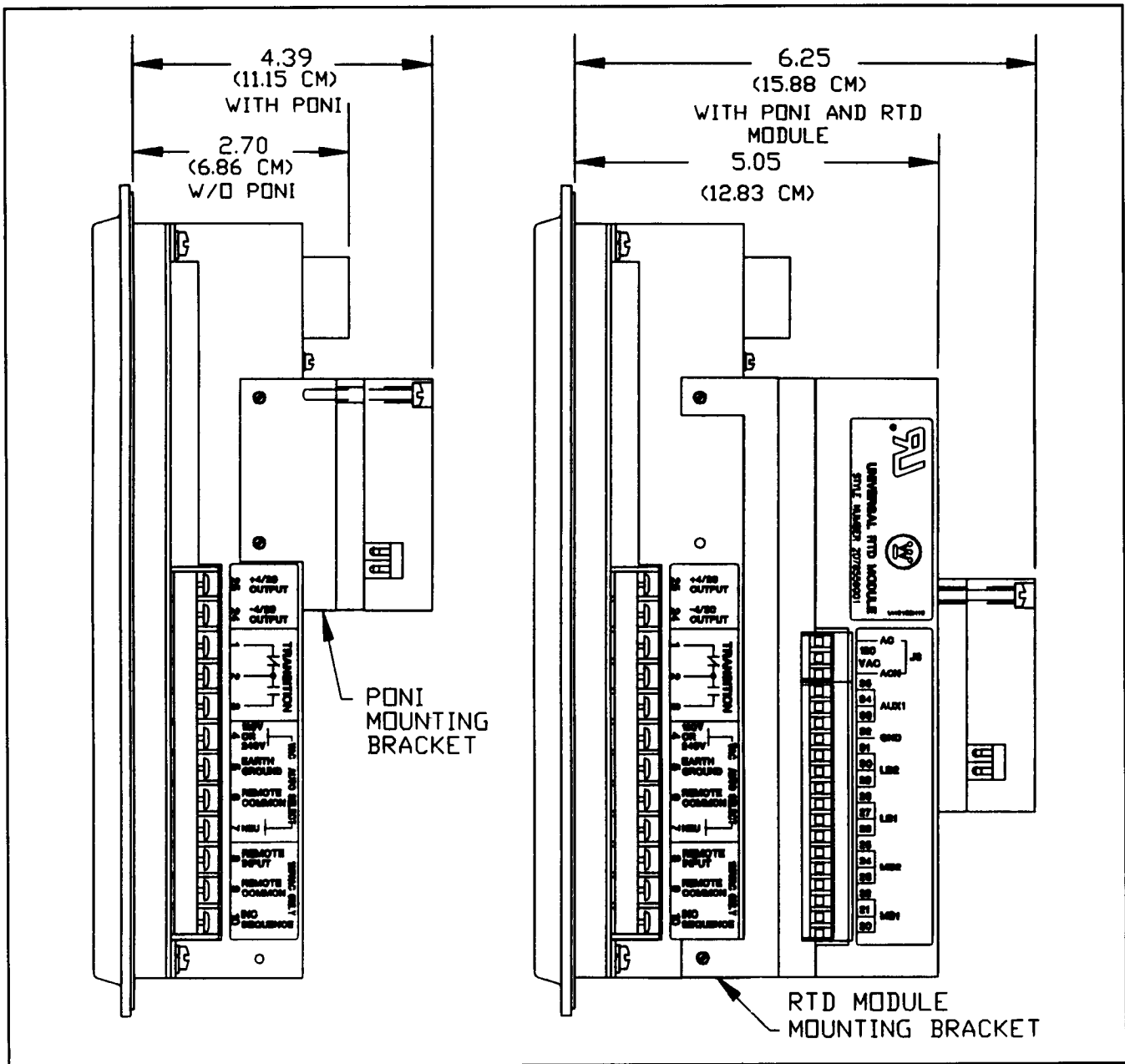

Figure 5.3 — IQ-1000 II Chassis Depth Clearances

There are no restrictions on the actual orientation of the RTD Module as long as the terminal blocks are accessible for wiring.

For additional information on the Universal RTD Module, consult IL 17367.

**NOTE**

All drawings and information in this manual concerning RTDs refer to the Universal RTD Module (Style Number 2D78559G01, Catalog Number URTD). If using an original RTD Module (Style Numbers 2D78508G01/G02/G03/G04), consult IL 17193 for features, dimensions, and mounting and installation instructions.

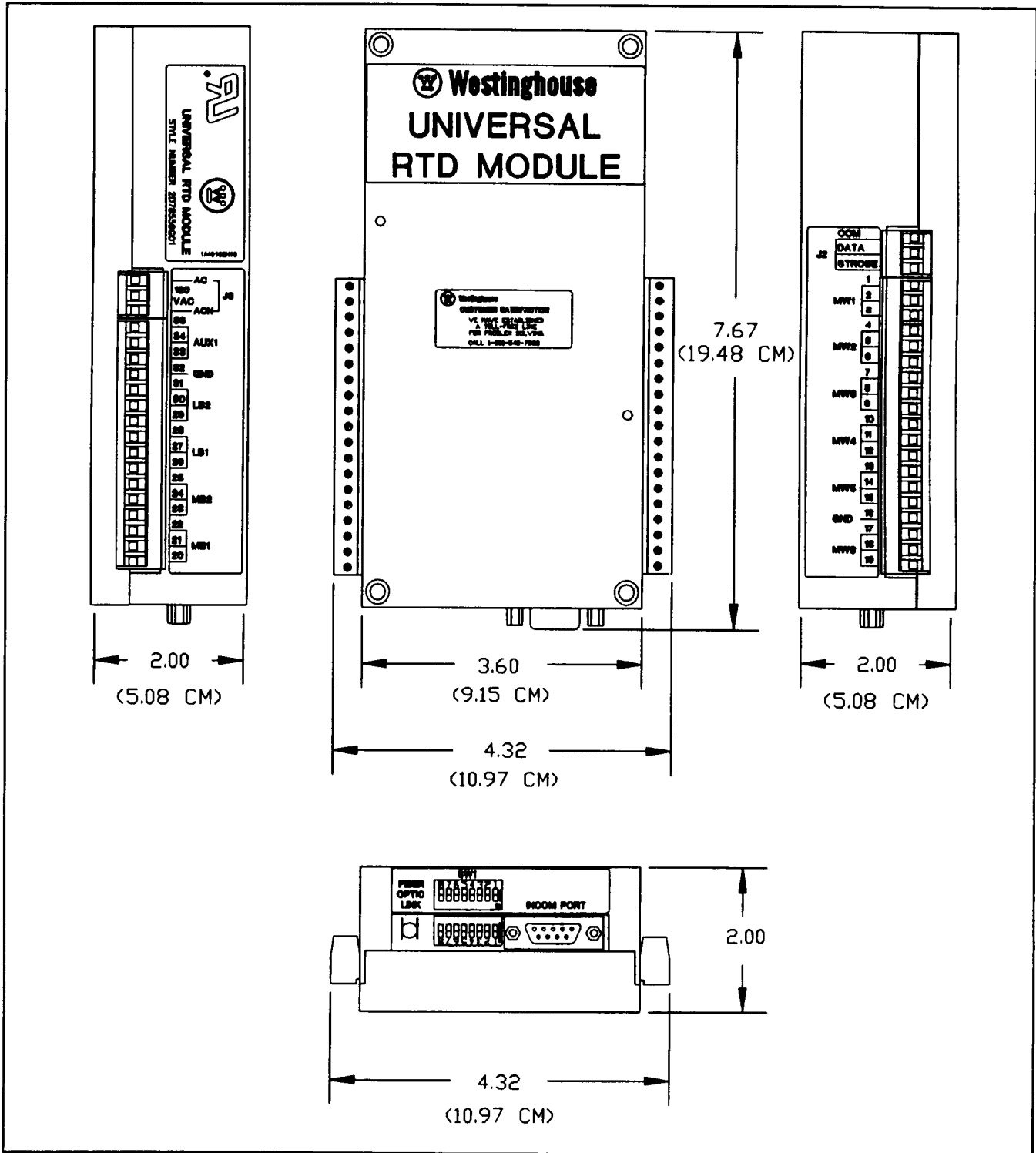

Figure 5.4 — Universal RTD Module Chassis Dimensions

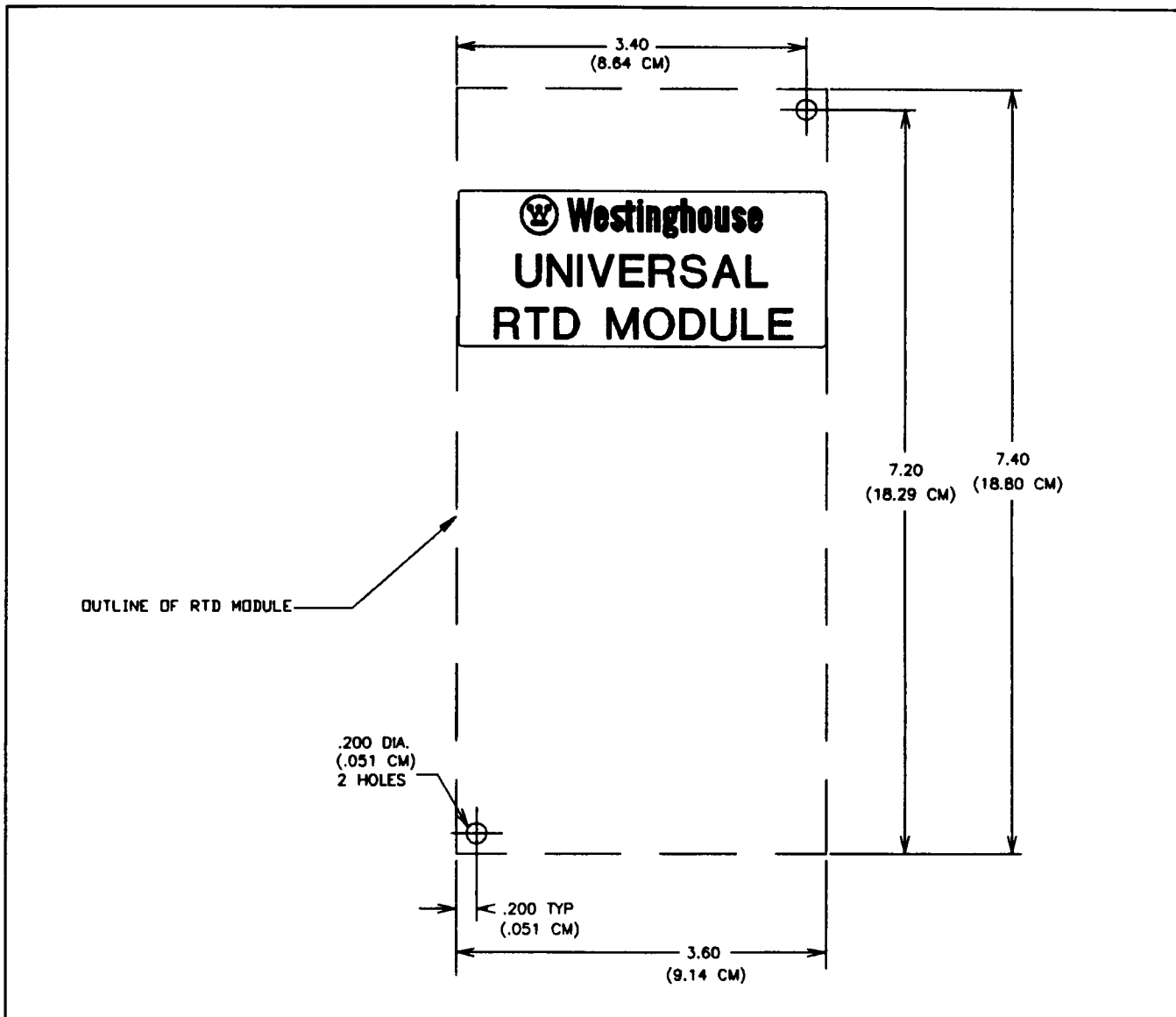

Figure 5.5 — Universal RTD Module Mounting Template Pattern

**5.1.3 Communications Option** — A Communications Module (PONI card) can be connected to the IQ-1000 II for transmission of all information from the device over an IMPACC network. A PONI mounted on an IQ-1000 II can be seen in Figure 5.3. Mounting and clearance information for the PONI card is contained in a separate Instruction Leaflet, IL 17361.

**5.2 Wiring – General** — The wiring of the IQ-1000 II must follow a suitable “Wiring Plan Drawing”. When the starter and the IQ-1000 II are supplied together from Westinghouse, the wiring is factory-installed, and a suitable Wiring Plan Drawing is supplied. Otherwise, the term refers to the drawings made for the specific application. They describe all electrical connections between the IQ-1000 II and the machine or process equipment. These are made up by the user or OEM and must include at least the following items:

- Wiring between IQ-1000 II and any interposing relays used
- Main contactor wiring

- Current transformers, ground fault transformer, and control power transformer wiring
- The RTD Option, if included in the application

A typical wiring plan is shown in Figure 5.7. Note that two jumpers are factory-installed between terminals 4 and 10 and 6 and 9. These jumpers are valid for either 120 VAC or 240 VAC operation. Remove these two jumpers ONLY if the Incomplete Sequence function is used in the application. If the Incomplete Sequence function is not used in the application, the two jumpers must be in place for proper functioning of the IQ-1000 II.

**NOTE**

The IQ-1000 II can accept 120 VAC or 240 VAC control power. All relays can accept 120 VAC or 240 VAC; however, Remote Trip/Reset and Incomplete Sequence terminals are 120 VAC rated only.

NO and NC contacts from the Alarm, Auxiliary Trip, Transition, and Trip Relays can be used to control external devices. These contacts are rated at 10 amperes (resistive) for 240 VAC or 10 amperes for 30 VDC. A +4/20 mA and -4/20 mA DC analog output is available from the IQ-1000 II for use with external devices such as an ammeter or a programmable controller. See Figure 5.8 for IQ-1000 II rear panel terminals.

Typical wiring for the RTD Option is shown in Figure 5.9. The exact RTD wiring for each application should be included in the Wiring Plan Drawings.

**DANGER**

Ensure that the incoming AC power and all "foreign" power sources are turned OFF and locked out before performing any work on the motor starter or IQ-1000 II. Failure to observe this practice can result in serious or fatal injury and/or equipment damage.

**5.3 Wiring Guidelines** — The following guidelines must be observed by the electrical crew when installing the IQ-1000 II.

**5.3.1 Wire Routing and Wire Types** — When routing wires between the starter and the associated machine or process equipment, follow these guidelines:

**Guideline 1** — Do not route the control or RTD wiring through the high-voltage compartment of the motor starter. If it is necessary to do so, consult Westinghouse Electrical Components Division for specific instructions.

**Guideline 2** — Separate the lower voltage (120 VAC) from the higher voltage (440 VAC, or higher) conductors as much as possible. In general, maintain a minimum distance of 1.5 ft. (45 cm) between the two types.

**Guideline 3** — Any low-voltage control wiring routed out of the motor starter cabinet should be at least #14 AWG stranded copper wire.

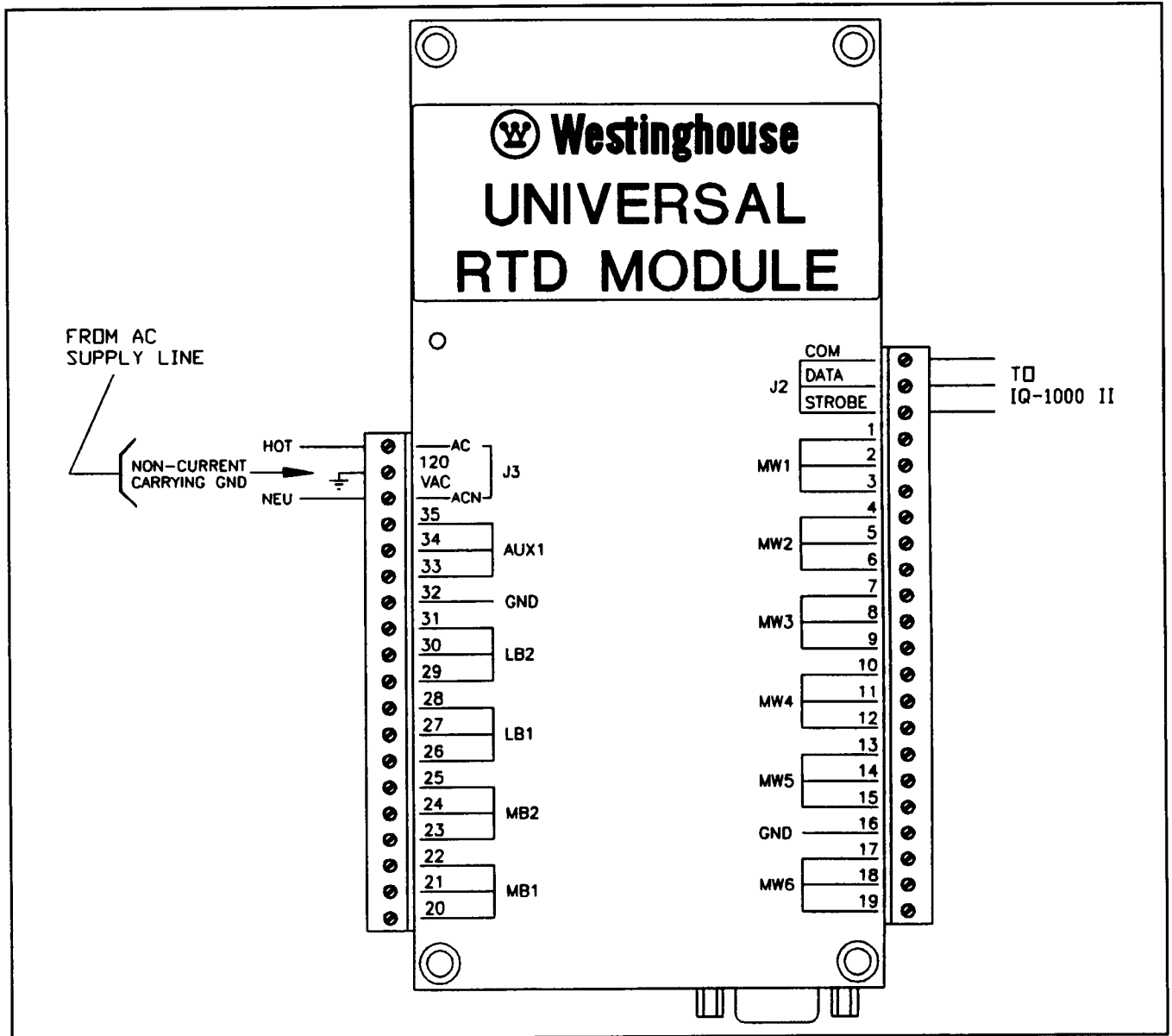

Figure 5.6 — Universal RTD Module Terminals

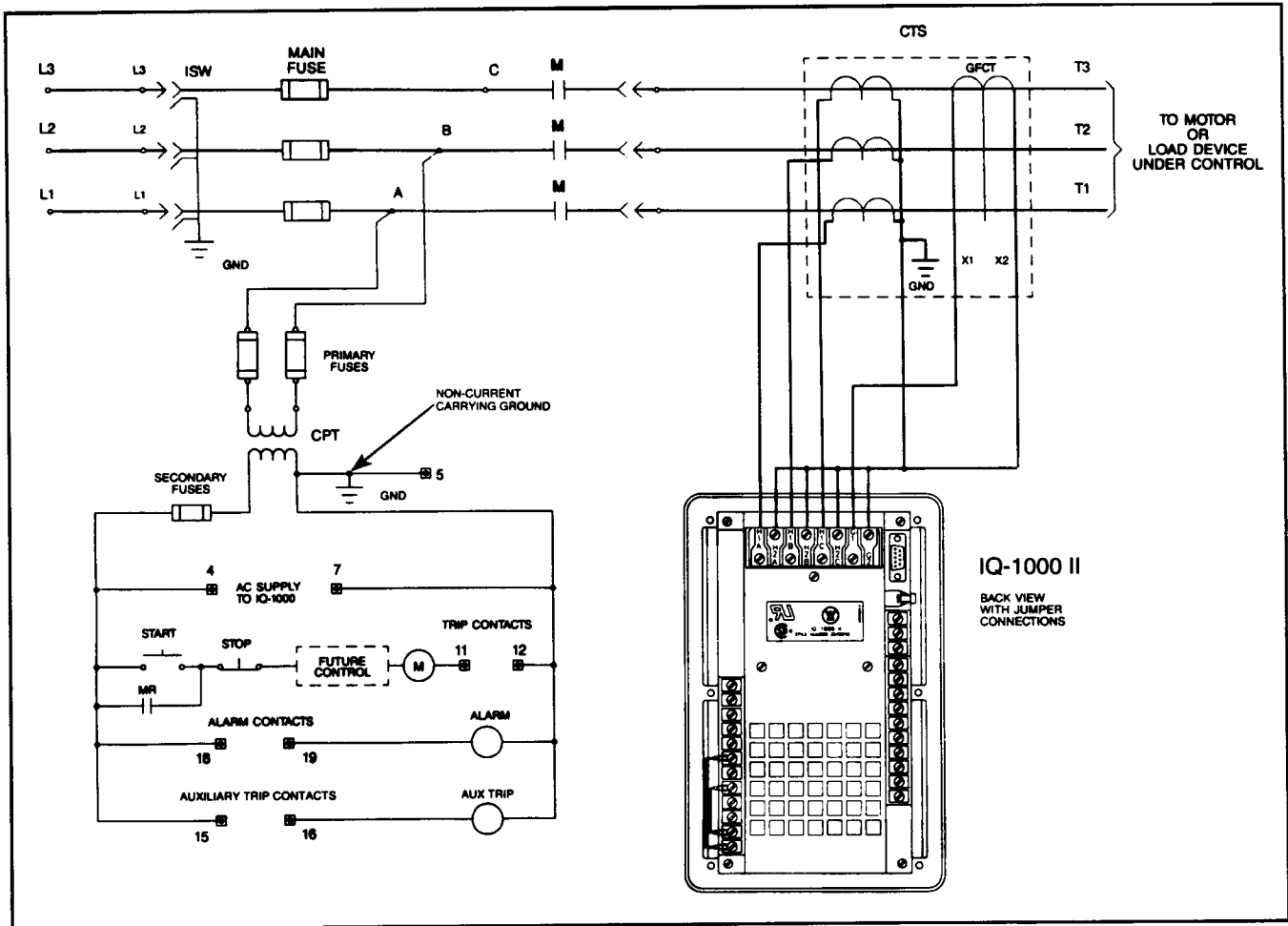

Figure 5.7 — Wiring Plan Drawing (partial plan)

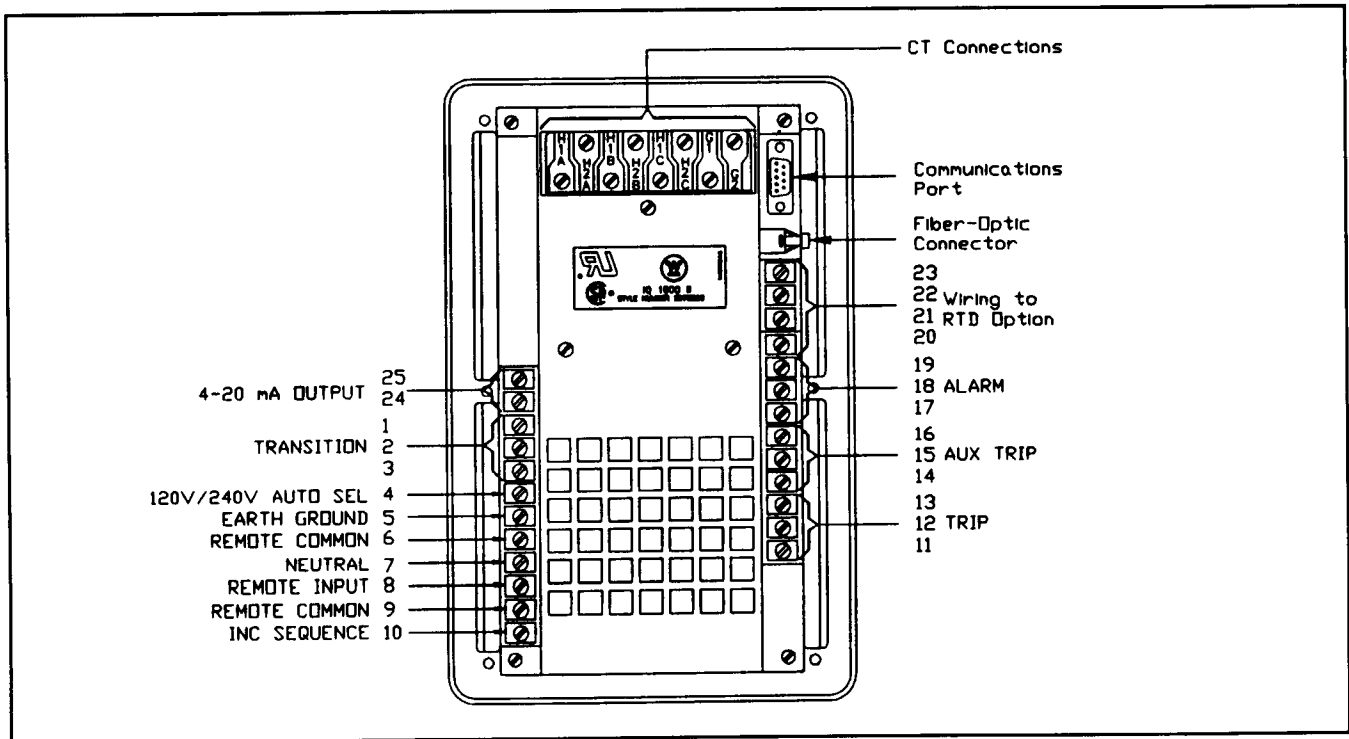

Figure 5.8 — IQ-1000 II Rear Panel Terminals

**Guideline 4** — The wiring between the IQ-1000 II and the RTD Module should be at least #14 AWG stranded copper, 3-conductor shielded cable.

**Guideline 5** — The wiring between the RTD Module and the RTDs in the motor must be #18 AWG, 3-conductor shielded cable.

**5.3.2 Wiring Connections** — Make wiring connections according to the application-specific Wiring Plan Drawing for each installation. Certain wiring connections are noted here for emphasis.

- Unused RTD inputs on the RTD Module should be wired together. For example, if MW5 and MW6 are unused, MW5 terminals 13, 14 and 15 should be wired to each other and MW6 terminals 17, 18 and 19 should be wired together.
- The interconnecting cable between the RTD Module and the RTD must have the cable's shield connected to the RTD Module ONLY. Cut the shield short at the RTD end and use shrink tubing or electrical tape to insulate it.

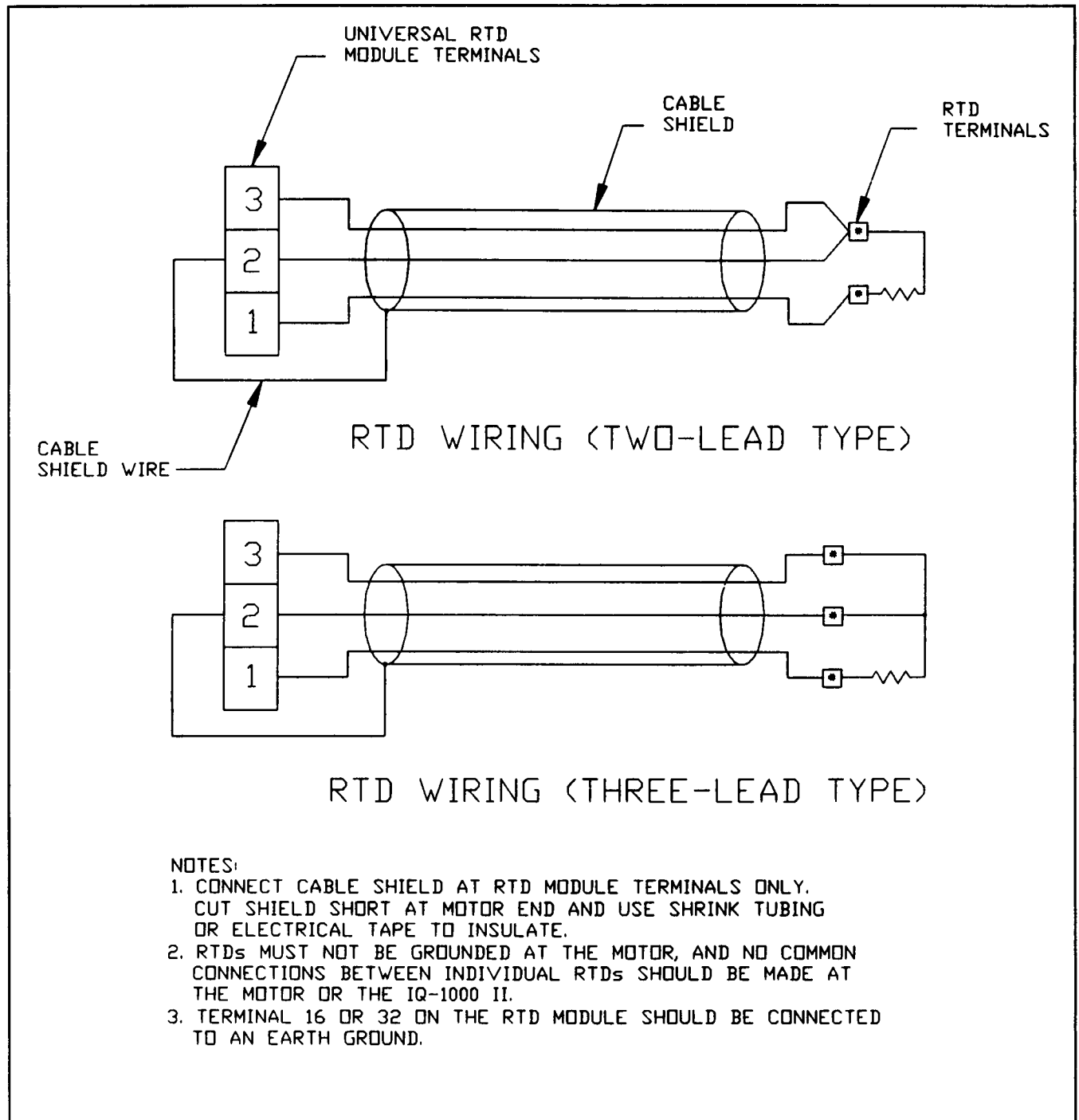

Figure 5.9 — RTD Wiring

- When making connections between the RTD Module and an RTD that has only two leads, connect two of the interconnecting cable's leads to one of the RTD's leads (see Figure 5.9). Make this connection as close to the motor as possible. Tie the third interconnecting lead to the remaining RTD lead.
- When making connections between the RTD Module and a three lead RTD, connect the shield and drain wire to the RTD Module terminal as shown in Figure 5.9.
- The Universal RTD Module accepts 120 VAC control power ONLY (see Figure 5.10). If the installation uses 240 VAC control power for the IQ-1000 II, a separate source 120 VAC must supply the Universal RTD Module.
- The IQ-1000 II accepts either 120 or 240 VAC inputs for control power or remote inputs (see Figure 5.11). All input relays are rated for 120 or 240 VAC with the exception of the Incomplete Sequence and Remote Trip/Reset terminals, which are rated for 120 VAC ONLY.

**5.3.3 Grounding** — The IQ-1000 II and associated system components must be grounded as follows to ensure proper operation:

- Connect the ground side of the control power transformer to terminal 7 of the IQ-1000 II.
- Connect one side of the CTs to the system ground. System noise may disrupt the IQ-1000 II if the CTs are tied to a current carrying ground.
- Connect a #14AWG wire between terminal 5 and the main ground bus of the system. **Do NOT connect terminals 5 and 7 together.** The ground connecting terminal 5 to the system ground bus must be a non-current carrying ground.

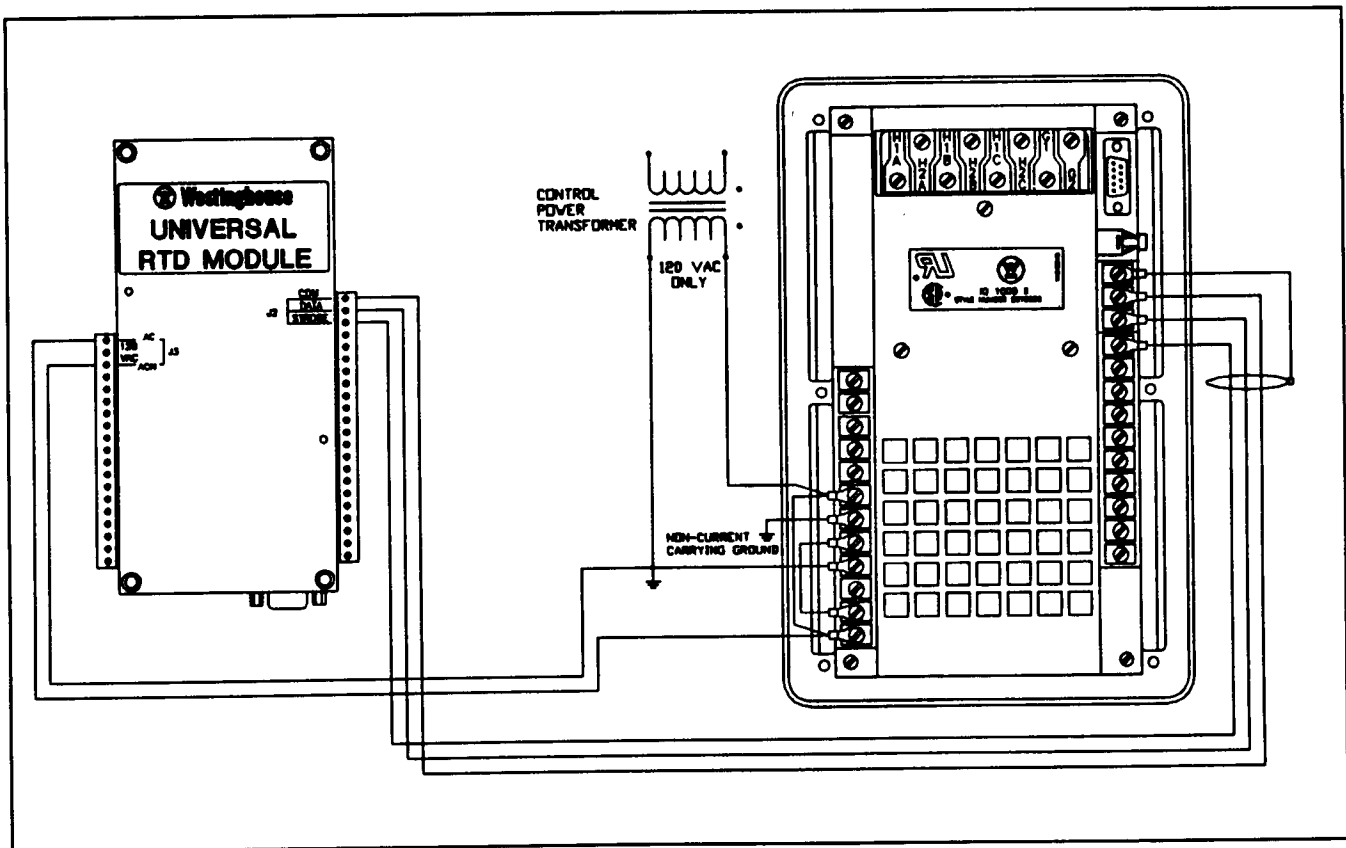

Figure 5.10 — IQ-1000 II to Universal RTD Module Control Wiring

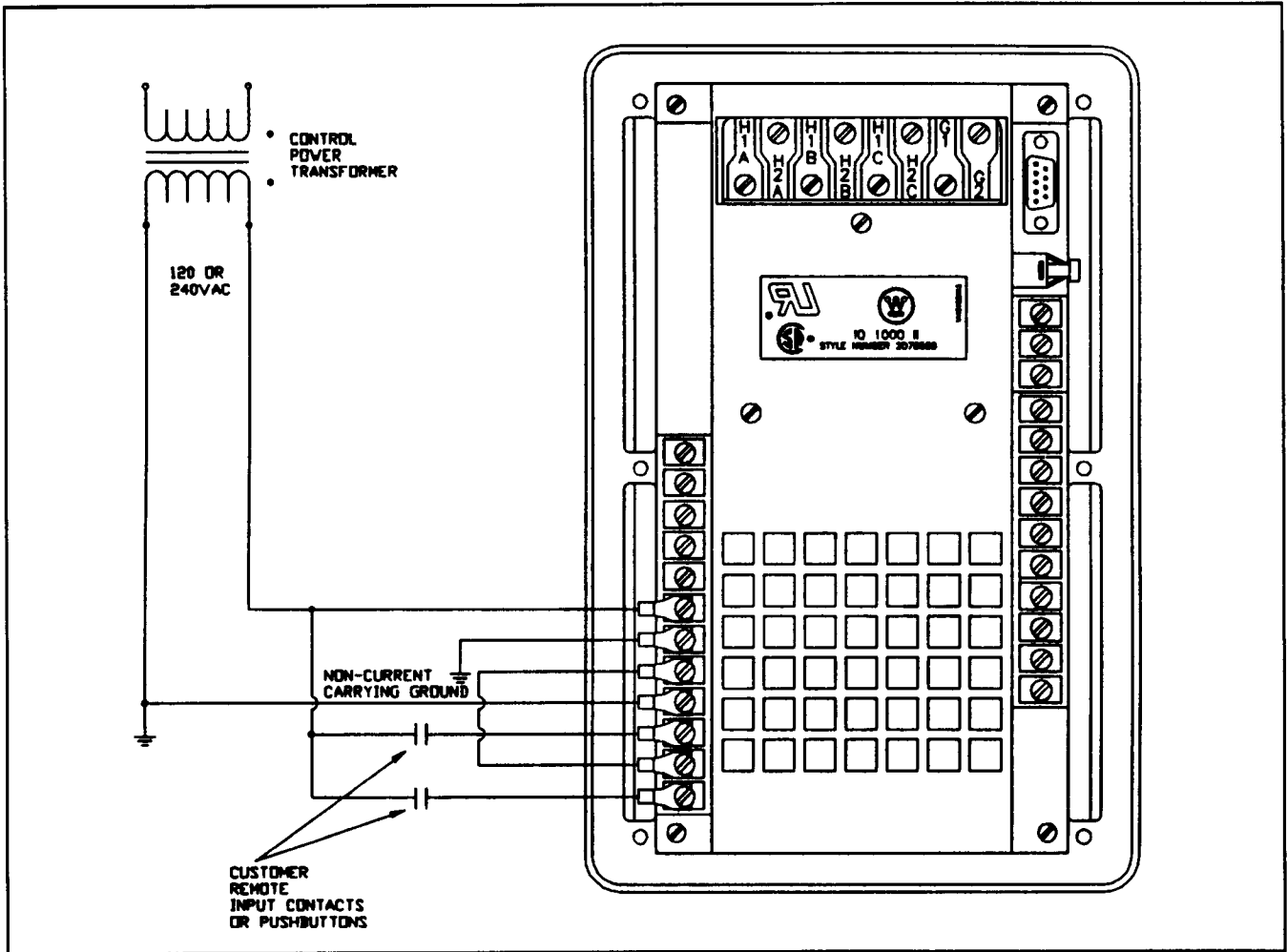

Figure 5.11 — IQ-1000 II Remote Input Wiring for 120 or 240 VAC Control Power

## Section 6

**STARTUP**

**6.0 General** — This section describes the procedure to follow when applying AC power to an IQ-1000 II, assuming that AC power has never been applied to the unit before. Each step in the procedure is shown below with a box to the immediate left, which may be used as a checklist to reduce the chance of omitting or skipping an item.

**DANGER**

Only qualified personnel familiar with the IQ-1000 II, the motor starter, and its associated mechanical equipment should perform the startup procedures listed here. Failure to comply can result in serious or fatal injury and/or equipment damage.

**CAUTION**

The IQ-1000 II is a solid-state device. Do not use a megger or perform high-potential testing on the connections associated with the unit. Failure to comply will result in equipment damage.

**6.1 Power Off Checks** — With the incoming AC power locked off at the isolation switch, perform these checks:

- Ensure that the isolation switch feeding the IQ-1000 II is in the OFF position.
- Ensure that there is no possibility of backfeeding control power through the control transformer, which will result in voltage being present on the primary of the transformer.
- Ensure that any foreign sources of power, such as those connected at the IQ-1000 II's relays' external terminals, are turned off.
- Ensure that the wiring associated with the application has been installed properly as shown on the Wiring Plan Drawing which was produced for the application.

**6.2 Initial AC Power Checks** — The following procedures describe the initial items to be performed when power is first applied to the IQ-1000 II. Refer to Figure 6.1 as necessary.

- With the power still OFF, disconnect the AC control power line to terminal 4.
- Connect an AC voltmeter between the wire just disconnected from terminal 4 and terminal 7.
- Turn AC power on.
- Measure the voltage and verify that a level of 120 VAC or 240 VAC is applied.

**NOTE**

If 240 VAC control power is being applied, and Incomplete Sequence option and/or Remote Input option is being used, verify that only 120 VAC will be present across terminals 8 and 9 and terminals 9 and 10. See Paragraph 5.2, **Wiring-General** and Figure 5.11 for additional 240 VAC wiring information.

- Remove AC power.
- If the AC power level is correct, reconnect the wire to terminal 4.
- If the AC power level is incorrect, consult the Wiring Plan Drawing and rewire, as necessary.

**6.3 Initial AC Power On** — The following procedure describes the initial items to be performed when AC power is first applied to the IQ-1000 II.

- Place the keyswitch in the Program position.
- Apply AC power to the application.

The message THINKING is displayed for a few seconds while the IQ-1000 II "initializes". Next, the software version number is displayed. At this time the IQ-1000 II is ready to accept set point values.

**NOTE**

While THINKING is present on the display, the IQ-1000 II is not protecting the motor. If the unit is in Mode 2, the trip relay contacts will be blocked open for 3 seconds.

**DANGER**

Do not attempt to enter any values without using the appropriate Set Point Record Sheet. Improper operation and/or personal injury could result if this procedure is not followed. See Section 8 for IQ-1000 II programming information.

- Enter setpoints as described in Paragraph 4.3. Use the filled-in Set Point Record Sheet (Table 8.B) for the specific application.
- After entering all setpoints, verify that each entry has been correctly entered as described in Paragraph 4.4.

**DANGER**

When the keyswitch is placed in the Protection position, the IQ-1000 II's Trip Relay will no longer prevent the motor's main contactor from closing. At this time the motor associated with the application can be started. It is important to ensure that all safety precautions associated with rotating equipment and the associated driven mechanism be taken. Failure to do so can result in serious or fatal injury and/or equipment damage.

- Ensure that all rotating members and driven mechanisms associated with the application's motor are properly and securely connected and free of any loose or foreign objects.
- Ensure that all personnel are cleared from the area of the application's motor and driven mechanics.
- Follow any startup procedures which may accompany the load equipment and refer to the application engineer who developed the Set Point Record Sheet or the associated mechanics if necessary.
- Turn the keyswitch on the IQ-1000 II to the Protection position. Start the motor using the external start switch or contacts.
- Using the information supplied by the application engineer or equipment manufacturer, verify that the motor is operating properly.
- With the motor running, use a clamp-on type ammeter to measure the AC line current on the main motor supply lines.
- Verify that the  $I_A$ ,  $I_B$ , and  $I_C$  currents as measured by the IQ-1000 II are within 15% of the currents as measured by the ammeter (see Paragraph 4.5 for the procedure to monitor motor parameters). This is not meant to verify accuracy of the IQ-1000 II; this procedure is to verify proper wiring of the current transformers and correct setting of the CT ratio. If there is a difference of greater than 15%, either the CT ratio is set incorrectly and/or the current transformers are incorrectly wired.

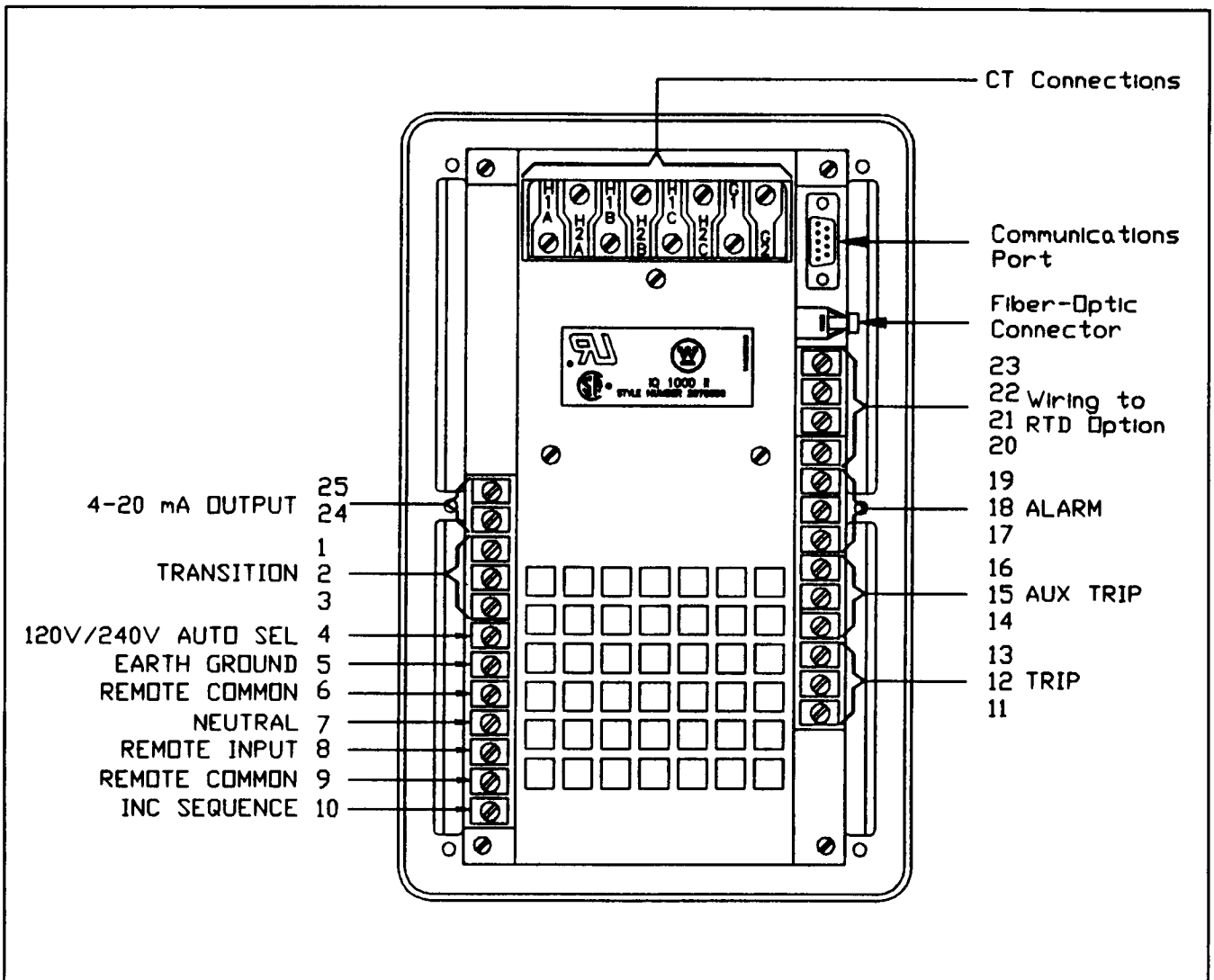

Figure 6.1 — IQ-1000 II Wiring Terminals

## Section 7

# APPLICATION CONSIDERATIONS

**7.0 General** — This section describes the protection and control characteristics of the IQ-1000 II, and is intended for the engineer who is responsible for matching the control to an individual application. Information presented here is especially useful for understanding setpoint considerations described in Section 8.

It may be helpful to read Sections 7 and 8 quickly, and then to reread and study Section 7 carefully. After doing so, reread Section 8 in order to select those setpoints from the program menu given in Table 8.B which relate to the specific application.

### NOTE

Throughout these explanations when specific functions are discussed, the program menu item number is also noted. This technique will help the reader understand the concept by relating it to Table 8.B, where more details are located.

**7.1 Motor Protection** — The IQ-1000 II protects the motor, starter, and load in the following ways:

- Motor overload protection
- Overtemperature protection
- Instantaneous overcurrent protection
- Ground fault protection
- Phase reversal protection
- Motor bearing temperature monitoring
- Jam protection
- Underload protection
- Load bearing temperature monitoring
- Incomplete sequence protection

**7.1.1 Overload Protection without RTDs** — The motor overload protection feature, called the I<sup>2</sup>T algorithm, calculates the rotor temperature of the motor based on the amount of current flowing into the motor. If no RTDs are present, the IQ-1000 II will proceed toward a trip only when the average current level of the 3 phases is above the ultimate trip level. A programmable I<sup>2</sup>T alarm (program menu item 20) informs the user when the IQ-1000 II is between 60% and 100% of the way to a trip.

The overload trip set point is determined as the maximum amount of I<sup>2</sup>T calculated by the IQ-1000 II which can be translated to the rotor. When the IQ-1000 II has accumulated enough I<sup>2</sup>T, a trip occurs and message LRC/I<sup>2</sup>T (Locked Rotor/Thermal Overload) is displayed. **The motor cannot restart until the temperature of the rotor, as calculated by the IQ-1000 II, falls below the alarm level set point entered into the**

**I<sup>2</sup>T alarm level function (item 20).** (The algorithm has both a heating and cooling calculation.)

To do this, the IQ-1000 II maintains a short-term history of the motor's operation (see Figure 7.1). The following variables are used as input data for the history:

- Motor current (I<sub>1</sub>), the positive sequence current
- Motor current (I<sub>2</sub>), the negative sequence, or "unbalanced," current
- Time

This data can be considered as the current feedback from the motor.

In addition to the current feedback from the motor, certain motor constants are needed. They are supplied to the IQ-1000 II when the user-chosen setpoints are programmed into memory. These are:

- Full-load amperes (item 42)
- Locked-rotor current (item 17)
- Maximum allowable stall time (item 18)
- Ultimate trip (item 19)

Using these motor constants, sampled motor currents, and time, the IQ-1000 II can track the calculated rotor temperature, always assuming a 40°C ambient temperature.

**7.1.2 Overload Protection with RTDs** — The temperature data obtained by employing optional RTDs is used by the IQ-1000 II in the following two ways to protect the motor:

- (1) Direct measurement of the winding temperature-versus-programmed trip temperature. (This gives a user-set fixed trip point based on actual, measured stator winding heating and cooling.)
- (2) RTD winding temperatures — when combined with the monitored positive/negative sequence motor current and the I<sup>2</sup>T algorithm for motor protection — incorporates the anticipated cooling of the rotor based on the actual stator winding temperature. (This is described in more detail in subparagraphs 7.1.3.6 and 7.1.4.)

The following motor input variables are used by the IQ-1000 II when the optional RTDs are used:

- Motor current (I<sub>1</sub>), the positive sequence current
- Motor current (I<sub>2</sub>), the negative sequence, or "unbalanced," current
- Time
- Stator winding temperature

This data can be considered as the feedback from the motor.

In addition to the variable data, certain motor constants are needed. They are supplied to the IQ-1000 II when these user-chosen setpoints are programmed into memory. These are:

- Full-load amperes (item 42)
- Locked-rotor current (item 17)
- Maximum allowable stall time (item 18)
- Ultimate trip (item 19)
- Winding temperature trip value (item 3)

The IQ-1000 II stores the chosen setpoint levels in its non-volatile memory and accurately measures feedback variables. Thus the unit protects the rotor by using the I<sup>2</sup>T algorithm, while the stator is protected by direct measurement through the RTDs.

**7.1.3 Protection Curve** — The motor protection curve defines the motor-versus-time relationship that is generated by the IQ-1000 II's application software, hardware, and programmed set

point values. Note Figure 7.2. Ideally, this curve is located as close as possible to the motor damage curve, thus allowing maximum utilization of the motor without damage.

(The motor damage curve is defined as that point in the relationship between the motor current and time where thermal damage results.)

When the motor current-versus-time relationship exceeds this damage curve, a trip condition occurs, and the motor is turned off.

The IQ-1000 II automatically calculates the correct motor protection curve for a specific application after the following items are entered: full-load amperes rating (item 42); locked-rotor current (item 17); maximum allowable stall time (item 18); and ultimate trip (item 19).

A brief discussion of how these values affect the motor protection curve is given in the following subparagraphs. The typical curve shown in Figure 7.2 is the result of the factors listed in these explanations.

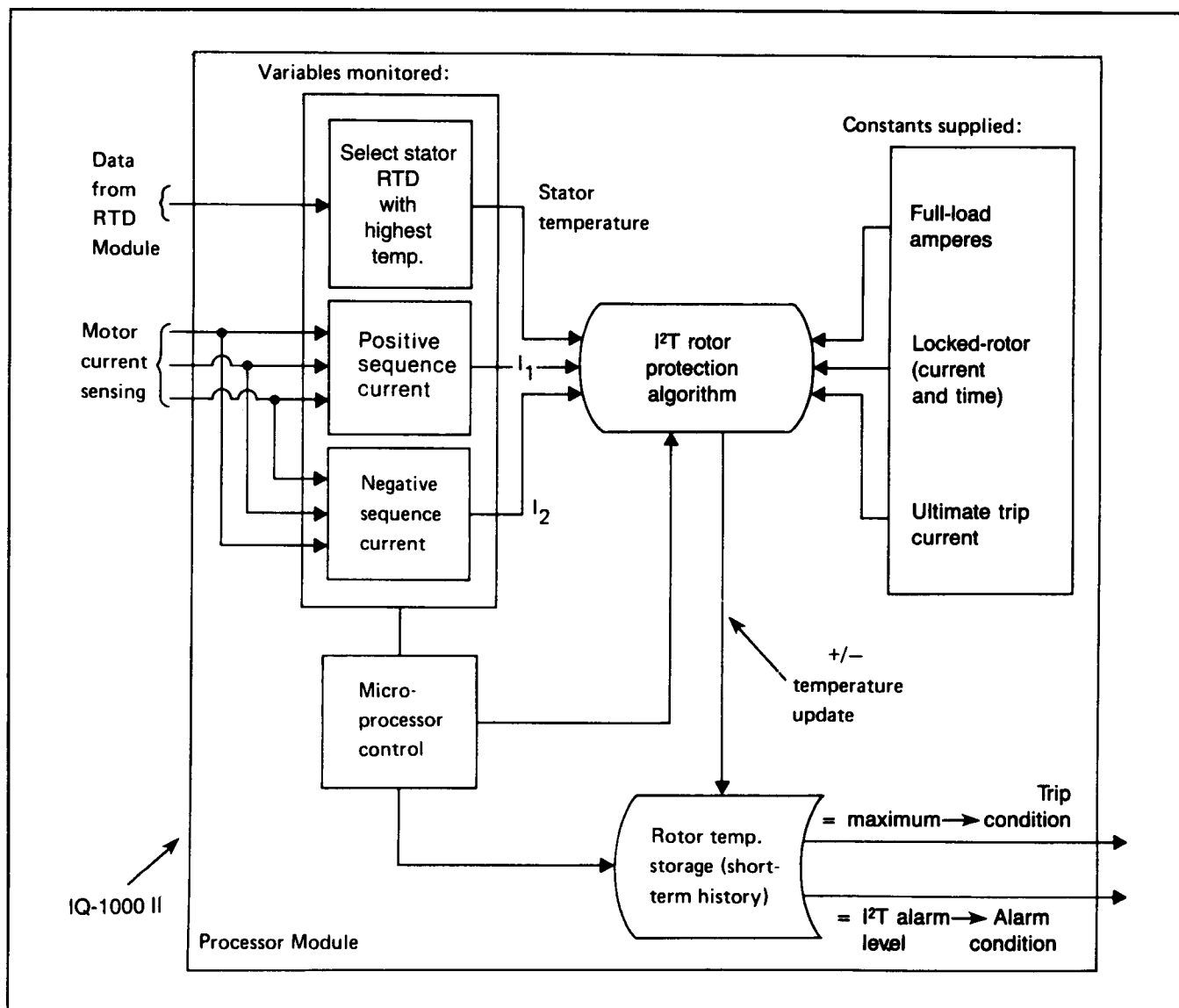

Figure 7.1 — Rotor Temperature Tracking

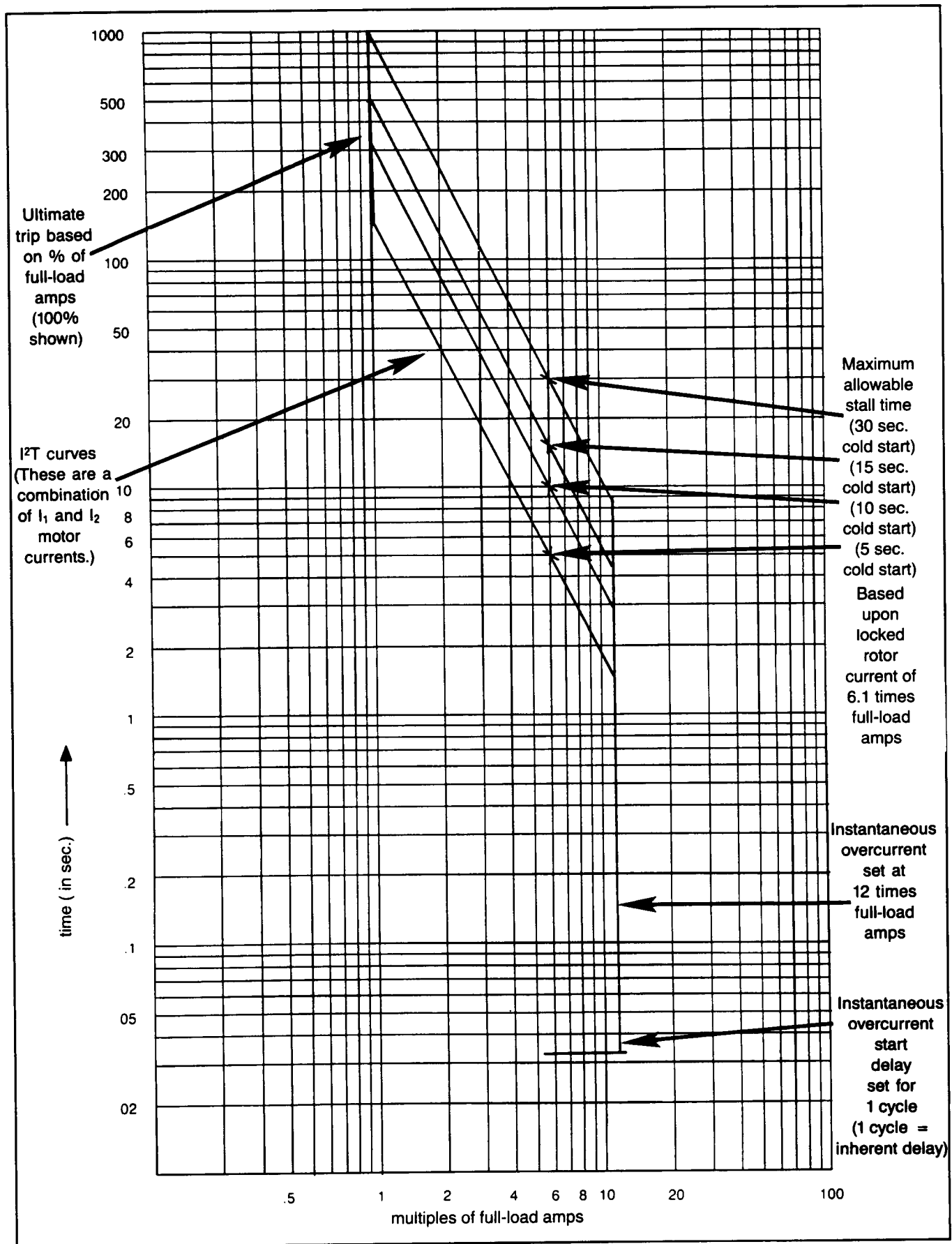

Figure 7.2 — Motor Protection Curve

**7.1.3.1 Instantaneous Overcurrent Function** — The specific instantaneous overcurrent (item 15) setpoint used in Figure 7.2 is 12 times (1200%) full-load amperes (item 42). In general, the instantaneous overcurrent setpoint for all applications should be at least 1.6 times the locked rotor current ratio. The instantaneous overcurrent setpoint available range is 300 thru 1600% of full-load amperes.

**NOTE**  
For the I.O.C. trip level to be effective, set it below your fuse interrupting rating or your contactor withstand capacity.

**NOTE**  
The instantaneous overcurrent start delay function (item 16) has a fixed minimum 1 cycle delay to detect the condition. The available setpoint range for additional start delay is actually 1 thru 20 AC line cycles.

**7.1.3.2 Locked-Rotor Function** — The family of curves shown in Figure 7.2 is based upon a locked-rotor current set point (item 17) of 6.1 times (610%) the full-load amperes function's (item 42) set point and a variable locked-rotor stall time set point (item 18).

All curves shown in Figure 7.2 are based on a maximum allowable stall time from a cold start. Since the IQ-1000 II's algorithm retains a history of both the operating current and operating time of the motor, it is not necessary to program it for hot starts. The unit automatically takes into consideration whether it is a hot or cold start. The locked-rotor set point, however, should be set for a cold start.

**7.1.3.3 Ultimate Trip** — The ultimate trip function's (item 19) set point is the lowest value of current above which the motor can be damaged over time. If the motor has a service factor larger than 100%, the ultimate trip level can be increased accordingly. A service factor of 1.25 could be used with a 125% ultimate trip level.

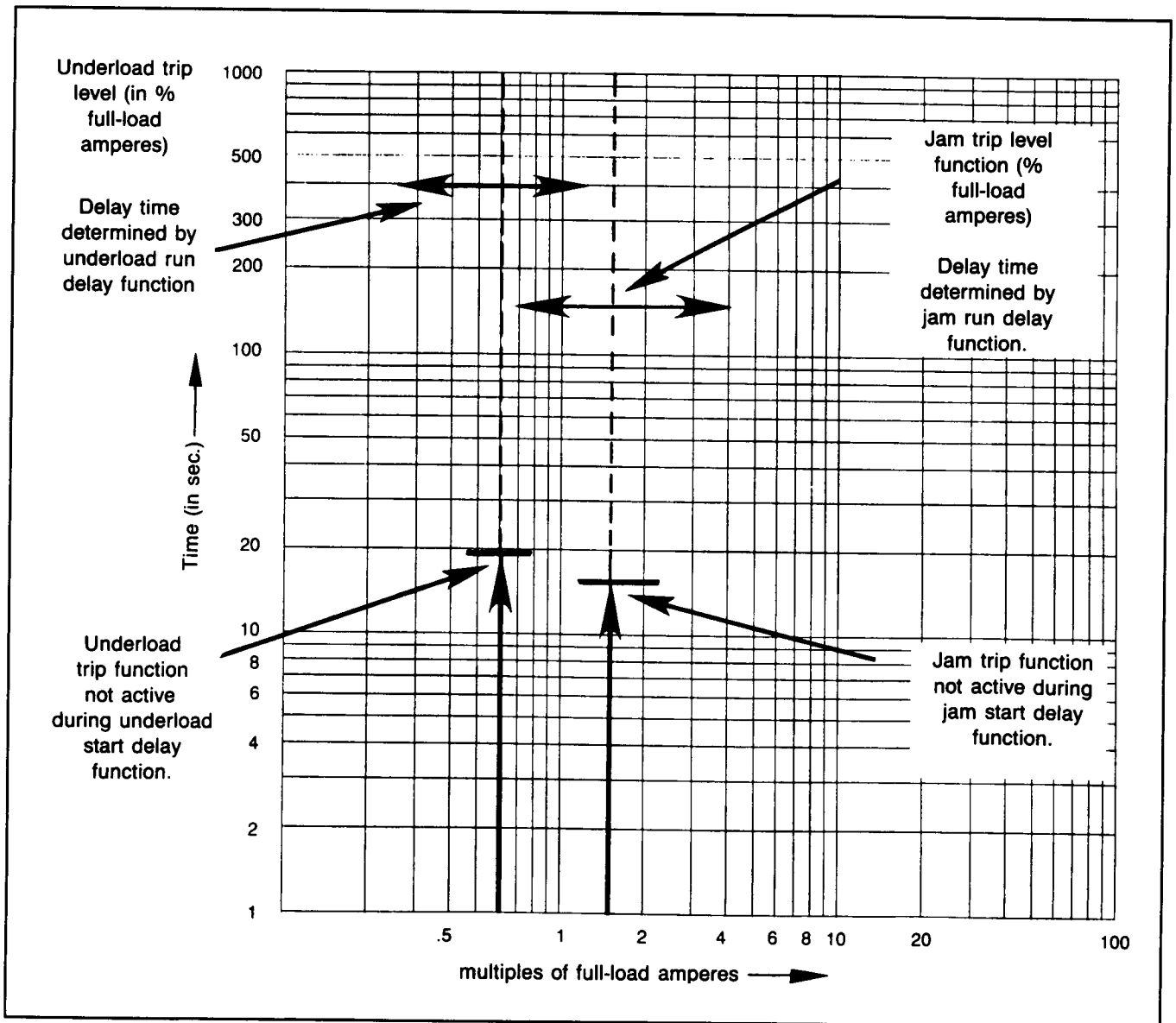

Figure 7.3 — Jam Protection Curve

**7.1.3.4 Underload Functions** — When the motor is running, a sudden current reduction indicates a malfunction in the driven equipment. If the current level falls below the user-set underload alarm value (item 26), an alarm condition exists. If the current falls below the underload trip level (item 27), a trip condition occurs and the motor is taken off-line.

Underload protection is used in the event of mechanical problems such as a blocked flow in a pump, loss of back pressure in a pump, or a broken drive belt or drive shaft. A programmable start delay (item 28) is provided to lockout the underload function while starting unloaded motors to prevent nuisance tripping. The run delay (item 29) is useful in applications where the motor is operated under light loads for short periods of time such as a conveyer system. To disable the underload trip function, program a value of 0 for item 27. To disable the underload alarm function, program a value of 0 for item 26.

**7.1.3.5 Jam Functions** — Once the motor is running, if the monitored current level exceeds the set point entered for the jam trip level (item 23), a trip occurs. (See Figure 7.3 in which the jam trip set point is 180% of full-load current.) An alarm level can also be programmed for jam (item 22).

In cases where the RTD Option is used, jam protection is especially desirable with gear train or other mechanical-type loads. In such cases an overload or physical jam could cause damage. A programmable start and run delay are provided to compensate for inrush current and momentary surges in the load.

If the jam trip function (item 23) is not desired, a value of 1200% should be entered along with a start delay of 1 second. (See Paragraph 8.10 for more details.) The jam alarm function can be disabled by programming item 22 for a value of 1200%.

**7.1.3.6 Temperature Effects** — Motor protection is directly related to the temperature of the rotor. If RTDs are not used, the IQ-1000 II assumes the ambient temperature to be 40°C. Thus the actual ambient temperature has no effect on either the starting or running of the motor.

The customer application engineer should take these factors into consideration and compensate for them if a higher ambient temperature is anticipated. The best solution is to use RTDs since any compensation for a higher ambient temperature results in overprotecting the motor during conditions of lower temperatures.

Without RTDs, the IQ-1000 II calculates the current and time, and then converts them to a calculated stator/rotor temperature. The constant I<sup>2</sup>T curve, as established by the locked-rotor current and maximum allowable time functions (items 17 and 18), is assumed to adequately protect the motor for all levels of motor current above the ultimate trip set point level. Should the curve not be adequate to protect the motor due to stator limitations at elevated ambient temperatures, then the use of RTDs is recommended. RTDs allow full utilization of the power available from the motor, and they reduce unnecessary shut-downs.

**7.1.4 Typical Motor Protection Curves** — To illustrate the IQ-1000 II's protection features, two sample curves are shown. Using specific motor data, typical motor protection curves of

the IQ-1000 II without RTDs are shown in Figure 7.4. The use of RTDs is assumed in Figure 7.5. The following data were used:

- Instantaneous overcurrent of 12 times full-load amperes
- Locked-rotor amperes of 6.1 times full-load amperes
- Maximum allowable stall time of 15 seconds, cold start
- Ultimate trip level of 100% of full-load amperes
- Start cycle set at 10 seconds (assumes a single-stage motor). (See items 37 and 38.)
- Motor running; loaded at 90% of full-load amperes
- Underload protection set point is 60% of full-load amperes
- Jam protection functions of 180% full-load amperes for a 5-second delay

The difference in the typical curve caused by the addition of RTDs is shown in Figure 7.5. It centers on the time period after 60 seconds. (When RTDs are used, the actual monitored temperature automatically overrides the ultimate trip function's setpoint.)

Note that the ambient conditions under which the motor is operating affect the top portion of the curve. The curve shifts to the left with increasing ambient temperature, and to the right with decreasing ambient temperature.

The effects of the motor winding temperature (items 3 and 7) setpoints, which can be used with RTDs, are not evident in Figure 7.5. These functions are independent of the effects of temperature on the I<sup>2</sup>T algorithm's trip curve. These functions' setpoints are based on the recommended maximum stator temperature, as supplied by the motor manufacturer. Depending upon the specific motor winding temperature setpoints, the temperature trip curve shifts to the left or right.

The IQ-1000 II allows maximum utilization of the power available from the motor by setting its trip conditions as close as possible to the motor damage curve.

**7.1.5 Motor Current** — The IQ-1000 II monitors both positive and negative sequence currents. Each is described in the following subparagraphs.

**7.1.5.1 Negative Sequence Currents** — Throughout the discussion of motor protection curves, the effects of negative sequence currents cannot be emphasized too strongly. For maximum motor utilization, the actual load should be matched closely to the full horsepower of the motor. However, when this is done, the effect of motor voltage unbalance — that results in the negative sequence current — becomes more critical.

The IQ-1000 II accurately calculates negative sequence currents in an ongoing manner. It is not necessary for the user to arbitrarily pick a specific set point percent of unbalance to shut the motor down. (However, see program items 30 and 31.) As long as the rotor temperature, as calculated by the IQ-1000 II, does not equal the motor damage curve, the motor continues to operate.

**7.1.5.2 Positive Sequence Currents** — The IQ-1000 II monitors true RMS motor current. It takes a total of 36 samples in each phase during a 1 cycle period in order to calculate the

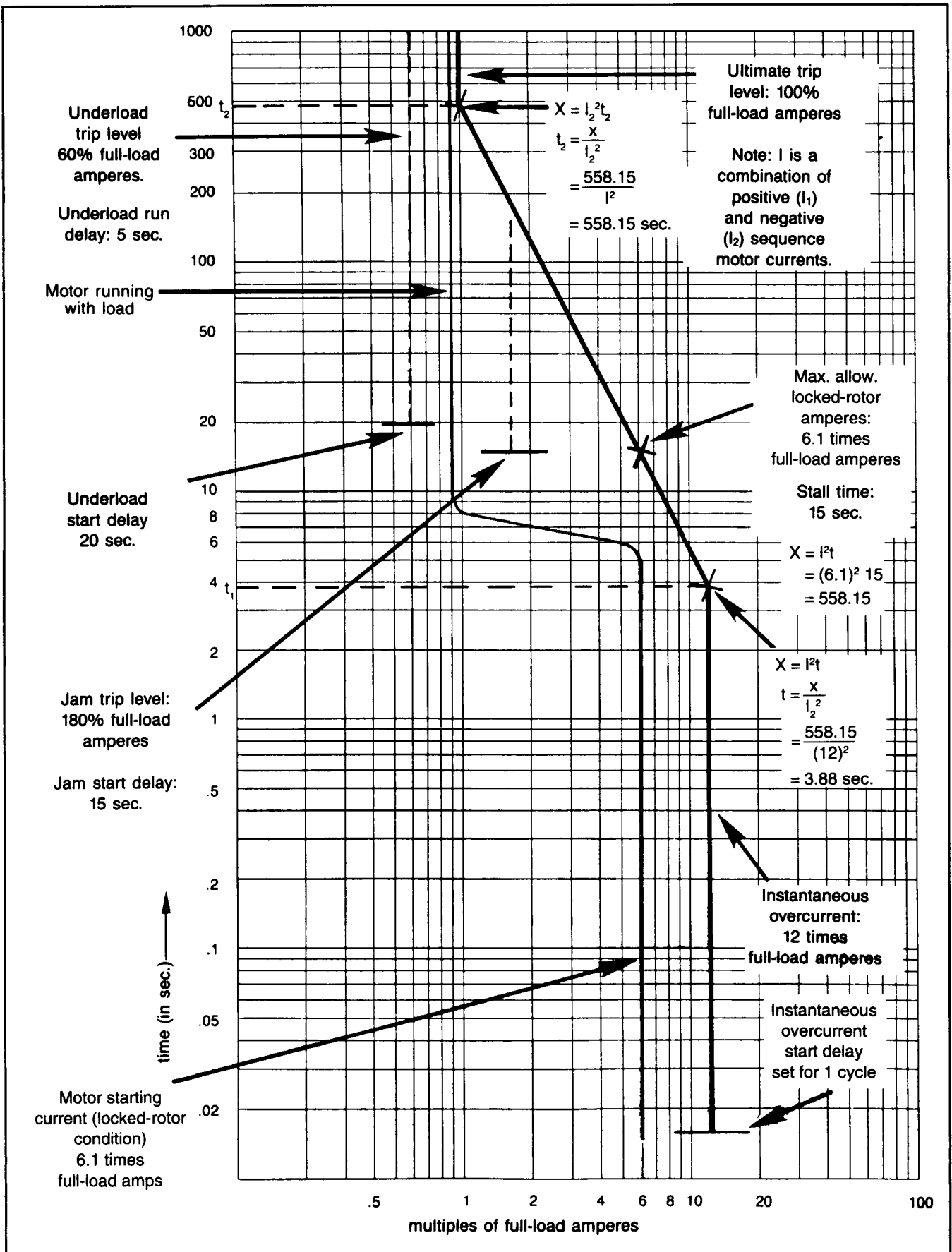

Figure 7.4 — Motor Protection Curve (without RTDs)

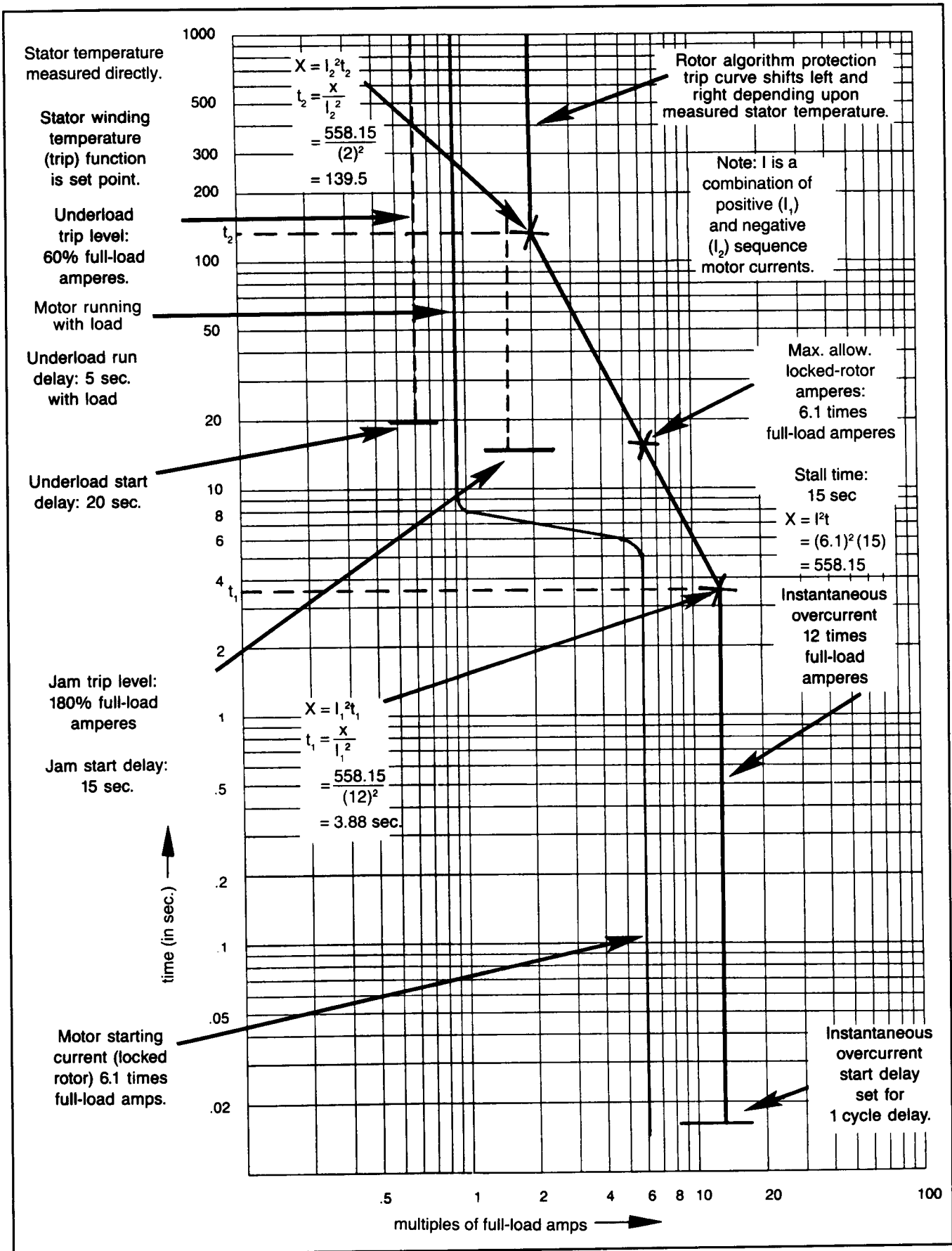

Figure 7.5 — Motor Protection Curve (with RTDs)

positive and negative sequence currents.

The sampling point is constantly shifting; thus the IQ-1000 II also monitors non-sinusoidal wave forms. This is important for applications where power factor correction capacitors and rectified systems are on the same main bus.

**7.1.6 Ground Fault Protection** — The IQ-1000 II's ground fault function (program menu item 11) provides protection against excessive leakage current levels. (The specific level is chosen by the user.)

Use of this function is restricted to a grounded system; it may not be used in an ungrounded system. The function requires that an optional ground fault (zero sequence) transformer be installed in the grounded system in which the secondary of the main power transformer feeding the motor is wired in a wye grounded configuration.

The optional ground fault transformer chosen must have a current transformer ratio of 50:5 to allow the IQ-1000 II to properly interpret the ground fault current level.

**7.2 Motor Cycle Monitoring** — As used here, the term "motor cycle monitoring" refers to the IQ-1000 II "passively" monitoring the motor during periods of normal operation. Normal operation includes the start cycle, run cycle, and stop cycle.

The word "passive" implies that the IQ-1000 II monitors motor current levels. It does not actually switch nor directly affect the

motor's contactors except when the Transition Relay, described in Paragraph 8.15, is used for reduced voltage starting, or a Trip Relay or Auxiliary Trip Relay is used to take the motor off line in a fault situation.

The following explanations center on the timing associated with motor starting, running, and stopping.

**7.2.1 Start Cycle** — The relationship between the IQ-1000 II and the motor current level during a start cycle is shown in Figure 7.6.

The motor start cycle is initiated when the motor current exceeds 30% of the full-load amperes setpoint (program menu item 42) assuming the motor was not in a trip condition. At this time the message "START" is displayed and the transition timer begins. The duration of the timer is determined by the motor start transition time (item 38) setpoint, which may be set to 0 seconds to disable the transition function.

The IQ-1000 II will transition if the current falls below the transition set point level (item 37). If a transition does not occur before the transition time expires, the IQ-1000 II will trip or transition at the user's choice. The run cycle begins as soon as the transition takes place. If transition time (item 38) is set to 0, the run cycle will begin immediately or a transition trip will occur, depending on item 39 of Table 8.B.

Once a start is declared, start delay timers will also begin timing, unless they are disabled (start delay timers are de-

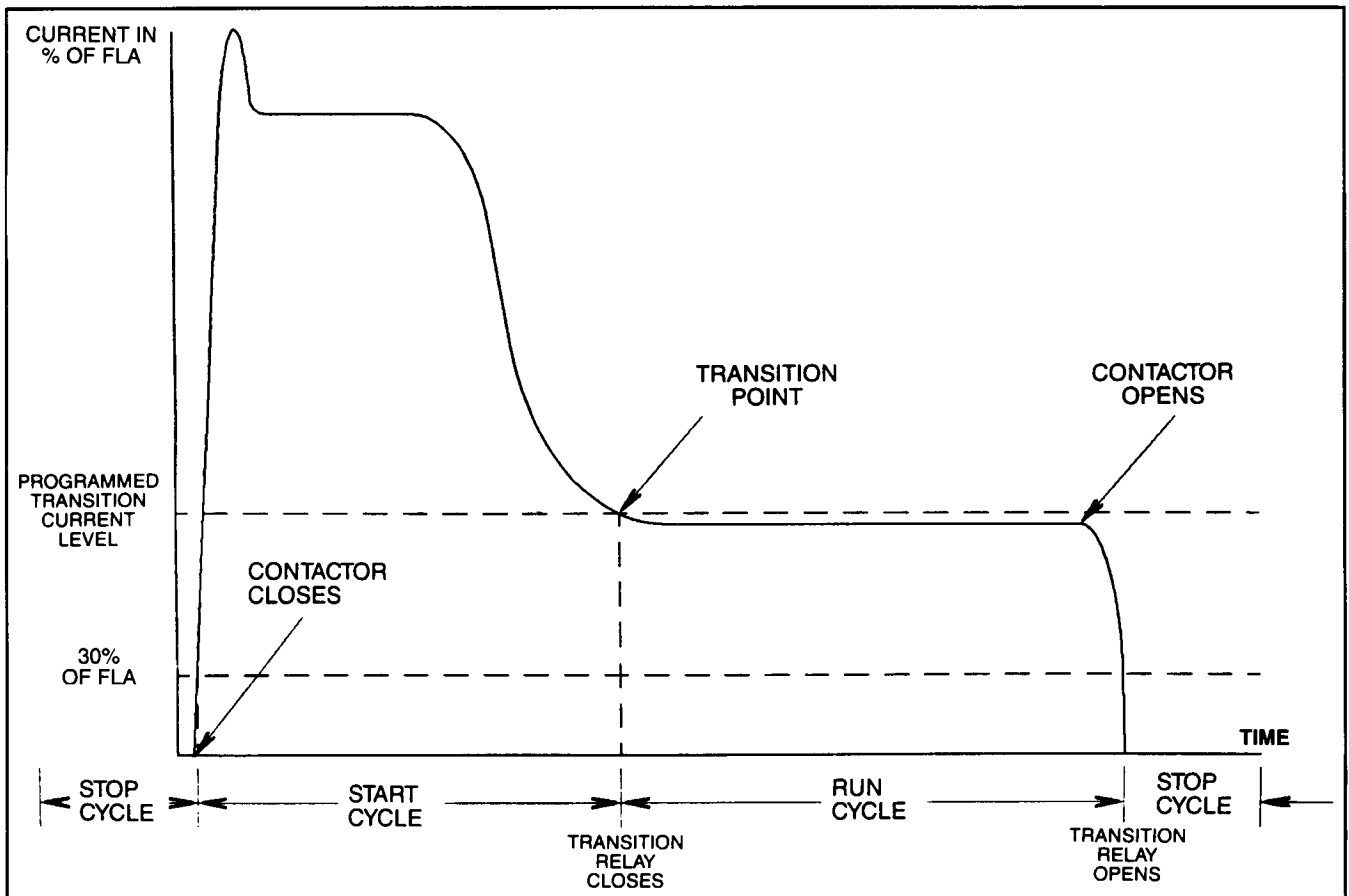

Figure 7.6 — Motor Start and Run Cycles

scribed in Paragraph 8.1.1). This group includes:

- Instantaneous overcurrent start delay timer. (Program menu item 16; described in Paragraphs 8.5.3 and 7.1.3.1.)
- Jam start delay timer. (Program menu item 24; described in Paragraph 8.10.3.)
- Underload start delay timer. (Program menu item 28; described in Paragraphs 8.11.3 and 7.1.3.4.)

Disabling the motor start transition (time) function (item 38) cancels any transition time, but these timers, if used, continue to operate independently of the duration of the start cycle. (See Paragraph 8.15 for details.)

**7.2.2 Run Cycle** — Once the transition occurs, the motor's run cycle is initiated and the message "RUN" is displayed. The run cycle continues until the monitored motor current level falls below 5% of its full-load amperes setpoint (item 42) at which point a stop is declared and the IQ-1000 II returns to the "READY -- 3" or stop mode. (See Figure 7.6.)

The run cycle is another normal motor operating state. Protection functions with run delays are active in this state once the start delay has expired. The primary function of run delays is to prevent nuisance tripping. These are:

- Ground fault run delay timer. (Program menu item 13; described in Paragraph 8.4.3.)
- Jam run delay timer. (Program menu item 25; described in Paragraphs 8.10.4 and 7.1.3.5.)
- Underload run delay timer. (Program menu item 29; described in Paragraphs 8.11.4 and 7.1.3.4.)
- Phase unbalance alarm run delay timer. (Program menu item 31; described in Paragraph 8.12.2.)

Keep in mind that run delays become enabled only after the start delay for that function has timed out. The actual run delay begins timing only after a transient trip condition occurs. (See Paragraph 8.1.)

**7.2.3 Stop Cycle** — When the monitored motor current level falls below 5% of the full-load amperes setpoint (program menu item 42), the stop cycle begins. When the IQ-1000 II is in the stop cycle, it can be in the Program mode, Ready mode, or any trip mode.

When the anti-backspin delay time function (item 41) is used, it is initiated along with the stop cycle. The anti-backspin function prevents a start cycle's initiation until the user-selected setpoint time elapses. (The Trip Relay and/or Auxiliary Trip Relay is used in this instance to prevent a motor start. See Paragraph 8.17 for more details.)

A second function also affects the stop cycle. This is the starts per time allowed function (program menu item 33). It prevents a motor from being restarted once the user-selected setpoint, in number of starts per a given time, is reached. (Here again the Trip and/or Auxiliary Trip Relay prevents the restart.) Only when the time allowed for starts count function's setpoint (item 34) has elapsed can a start cycle be initiated (see Paragraph 8.14).

**7.3 AC Line Interruptions** — The IQ-1000 II operates in a controlled and predictable manner during incoming AC line

interruptions. The events flow chart shown in Figure 7.7 lists the predictable events which occur during various AC line interrupts for a typical motor. The chart assumes a complete, or nearly complete, loss of AC line power.

Study the figure and note that at least 3 AC cycles must occur before any of the following events occur. What occurs is either the IQ-1000 II initiates a power-down condition or the main contactor drops out. As indicated in the figure, the factors which determine which of the conditions occur are:

- The loading of the IQ-1000 II's power supply at that time
- The type of contactor being used

In either case, if AC power remains off, eventually the IQ-1000 II initiates a "power-down condition". In this case the microprocessor has lost intelligence due to the low voltage condition and will perform a power-up reset when power is restored.

#### NOTE

The IQ-1000 II will display the message "THINKING" for approximately three seconds after the unit is powered up. The motor is not being protected during this time and will not be allowed to start if the unit is in Mode 2 operation (see Paragraph 8.20).

**7.4 Control Signal Wiring** — The IQ-1000 II communicates with the motor, contactor, and the associated machine or process through the following means:

- Discrete inputs from devices such as pushbuttons or relay contacts
- Outputs, in the form of relay contacts

Each of these topics is discussed separately in the following subparagraphs.

Additionally, there are other sensing inputs from the optional ground fault transformer and current transformers. (These are not discussed here.)

The following two inputs are available and may optionally be used:

- REMOTE INPUT (terminal 8 on rear of unit). This input is used either to externally reset from a trip condition, to initiate a trip condition, or to detect a motor stop (see Paragraph 8.22).
- INC SEQUENCE (terminal 10 on rear of unit). This input affects the incomplete sequence report back function (program menu item 40) associated with the transition operation (see Paragraphs 7.2.1 and 8.16 for details).

**7.4.1 Discrete Inputs** — The discrete input terminals, if used, accept user-supplied 120 VAC from field devices such as switches, pushbuttons, relay contacts, etc. The IQ-1000 II's input contacts must remain closed for a minimum time of 17 cycles in order for the new state to be reliably sensed by the IQ-1000 II. This duration allows a distinction to be made between electrical noise and the actual 50/60 Hz signal. The characteristics of the circuits associated with these inputs are listed in Table 7.A.

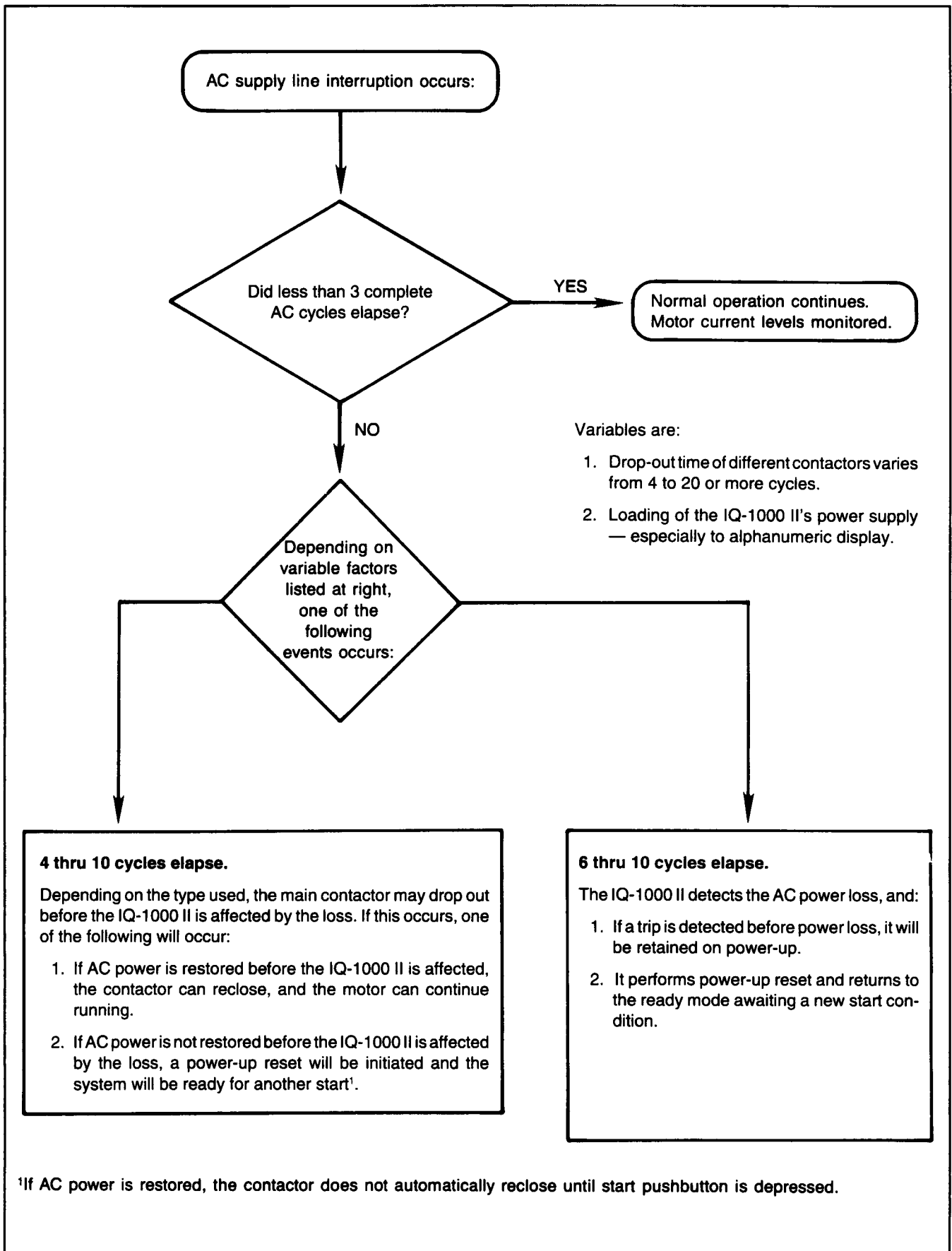

Figure 7.7 — AC Interrupt Events Flow Chart

**DANGER**

When planning discrete input wiring, ensure that the leakage current to the input terminals does not exceed 10 mA. 50/60 Hz leakage currents can be excessive when discrete input signals are derived from certain control devices or input devices are separated from the IQ-1000 II by long wire runs. An example of this dangerous situation could involve the remotely located contacts of a programmable controller's output module. These could have a leakage greater than 10.0 mA. Excessive leakage currents can cause spurious signals at the IQ-1000 II's discrete input terminals. These may interfere with the start and run cycles' motor sequences. Erratic sequences may cause personal injury or equipment damage.

Table 7.A

**DISCRETE INPUT CIRCUIT CHARACTERISTICS**

Characteristic	Specification
Input voltage	120 VAC ONLY
Opto isolation	1500 volts
Input impedance	26K ohms
Input current drain (ON)	4.5 mA
Input current drain (OFF, max.)	10.0 mA

**7.4.2 Output Contacts** — The IQ-1000 II's output contacts correspond to the externally accessible terminals of the internal relays, as shown in Figure 7.8. These are all rated as:

- 240 VAC at 10 amperes (resistive)
- 30 VDC at 10 amperes (resistive)

The Trip, Transition, and Auxiliary Trip Relays are discussed throughout Section 8, but especially in Paragraphs 8.14 thru 8.20.2. Also, see Paragraph 3.2 for the Auxiliary Trip Relay.

**7.5 Wiring Considerations** — A suitable wiring plan that shows the interconnections between the IQ-1000 II and the associated machine or process must be developed by the user. This paragraph contains information needed by the application engineer who is developing a specific wiring plan. A typical example of a wiring plan is shown in Figure 7.9.

All wiring must be in conformance with the National Electrical Code as well as any other applicable state and/or local codes.

**7.5.1 Wire Routing and Wire Types** — When routing wires between the starter and the associated machine or process equipment, follow these guidelines:

**Guideline 1** — Do not route the control or RTD conductors through the high-voltage compartment of the motor starter. If it is necessary to do so, consult Westinghouse Electrical Components Division for specific instructions.

**Guideline 2** — Separate the lower voltage (120 VAC) from the

higher voltage (440 VAC, or higher) conductors as much as possible. In general, maintain a minimum distance of 1.5 ft. (45 cm) between the two types.

**Guideline 3** — Any low-voltage control wiring routed out of the motor starter cabinet should be at least #14 AWG stranded copper wire.

**Guideline 4** — The wiring between the IQ-1000 II and the RTD Module should be at least #14 AWG stranded copper, 3-conductor shielded cable.

**Guideline 5** — The wiring between the RTD Module and the RTDs in the motor must be #18 AWG, 3-conductor shielded cable.

**7.5.2 RTD Wiring** — If the optional RTD Module is used, each RTD must be wired as shown in Figure 7.10. Also, note the following requirements:

- Use 10-ohm copper, 100-ohm platinum, 100-ohm nickel, or 120-ohm nickel RTDs. The Universal RTD Module is DIP switch selectable to read any of these types of RTDs.
- Unused RTD inputs on the RTD Module should be wired together. For example, if MW5 and MW6 are unused, MW5 terminals 13, 14, and 15 should be wired to each other and MW6 terminals 17, 18 and 19 should be wired together.
- The interconnecting cable between the RTD Module and the RTD must have the cable's shield connected to the RTD Module ONLY. Cut the shield short at the RTD end and use shrink tubing or electrical tape to insulate it.
- When making connections between the RTD Module and an RTD that has only two leads, connect two of the interconnecting cable's leads to one of the RTD's leads (see Figure 7.10). Make this connection as close to the motor as possible. Tie the third interconnecting lead to the remaining RTD lead.
- When making connections between the RTD Module and a three lead RTD, connect the shield and drain wire to the RTD Module terminal as shown in Figure 7.10.

**7.5.3 Grounding** — The IQ-1000 II should be connected as follows to ensure proper operation:

- Connect the ground side of the control power transformer to terminal 7 of the IQ-1000 II.
- Connect a #14 AWG wire between terminal 5 and the main ground bus of the system. **Do NOT connect terminals 5 and 7 together.** The ground connecting terminal 5 to the system ground bus must be a non-current carrying ground.
- Connect one side of the CTs to the system ground. System noise may disrupt the IQ-1000 II if the CTs are tied to a current carrying ground.

The sizing and type of insulation for the AC supply line and the grounding electrode conductor must be in conformance with the National Electrical Code.

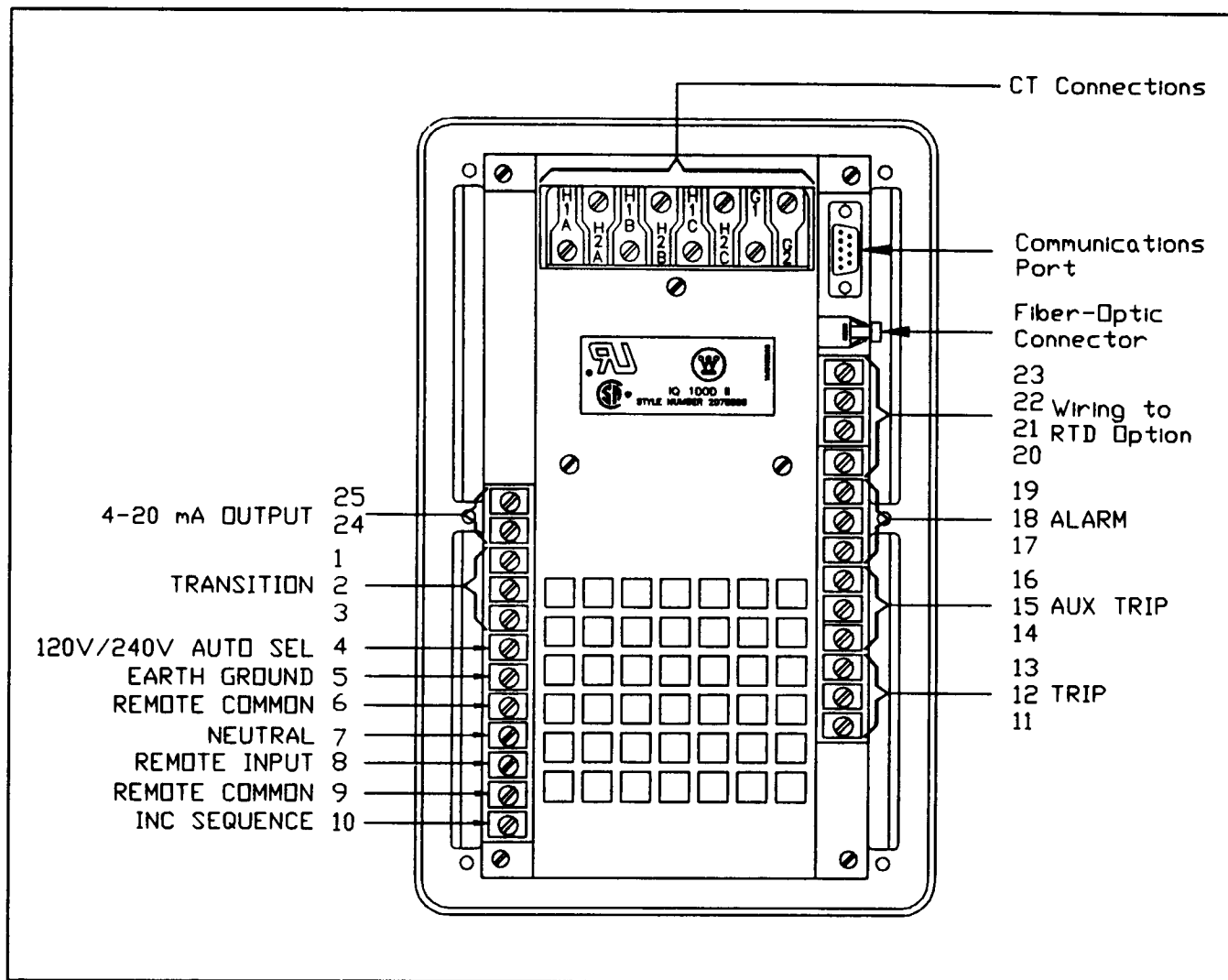

Figure 7.8 — IQ-1000 II Rear Panel Terminals

**7.6 Environmental Considerations** — Consideration must be given to the location of the IQ-1000 II enclosure in the plant. The unit operates within an ambient range between 0 to 70°C (32 to 158°F) with a humidity factor of 95% non-condensing.

The IQ-1000 II's circuit boards are conformal-coated to withstand environmental contaminants. However, special precautions may be required for extremely dirty or corrosive environments (consult Westinghouse Electrical Components Division).

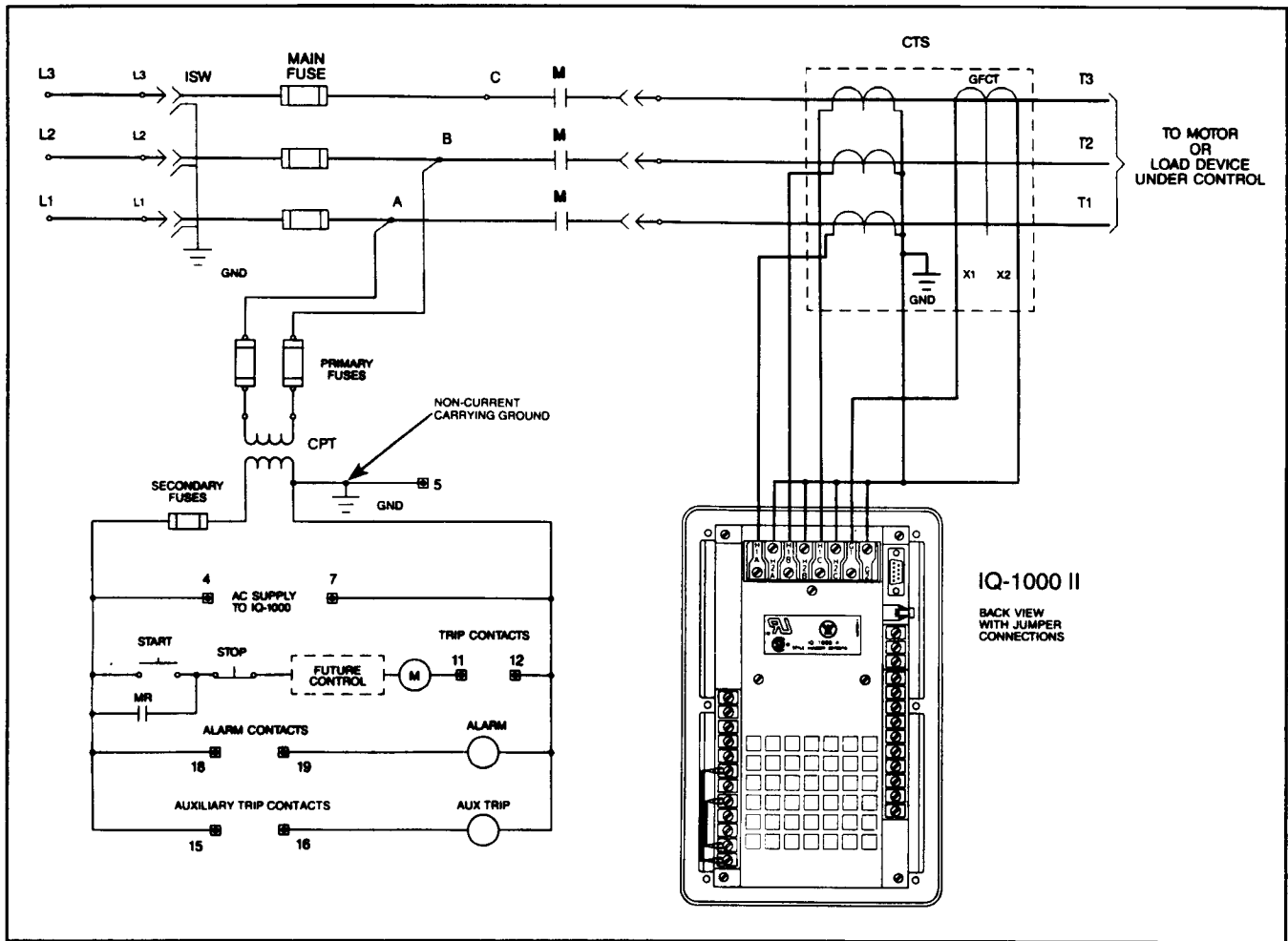
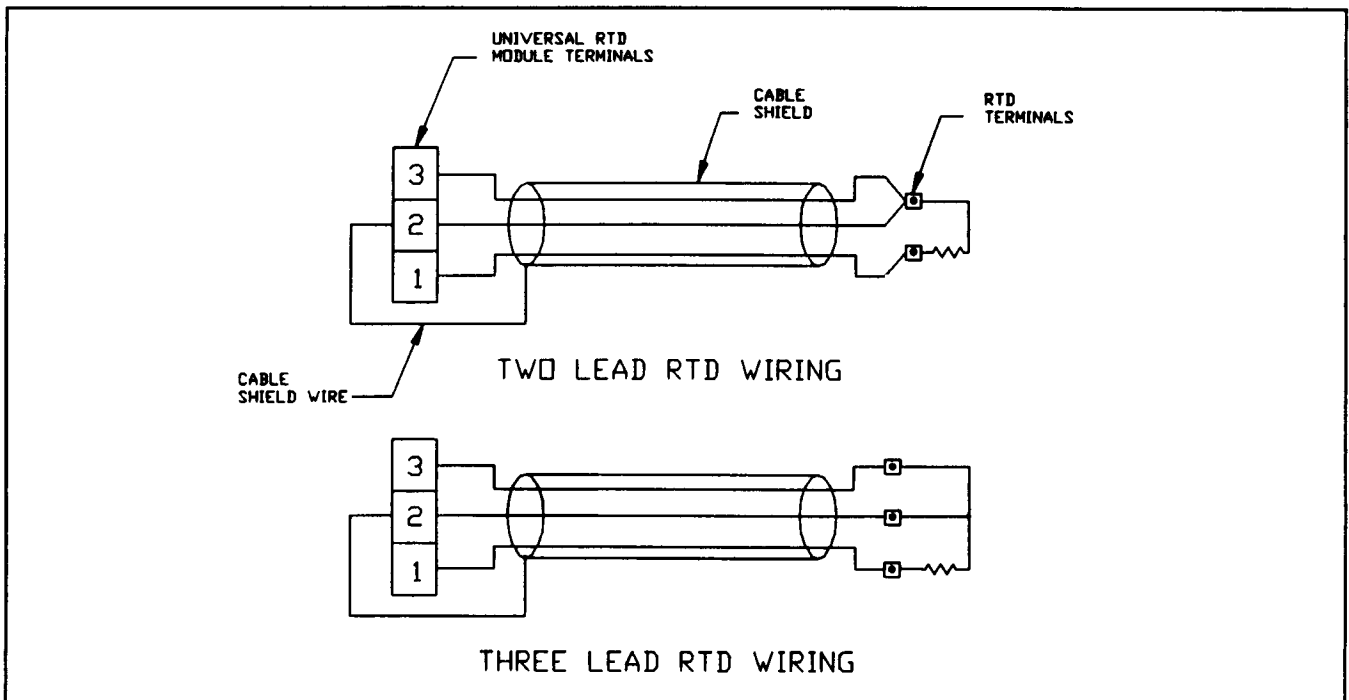

Figure 7.9 Partial Wiring Plan Example



7.10 — RTD Wiring Examples

## Section 8

# PROGRAMMING THE IQ-1000 II AND SET POINT DESCRIPTION

**8.0 General** — This section contains information needed by an application engineer to organize the setpoint values for a specific IQ-1000 II so that they may be easily entered. Thirty-eight separate functions are provided. (See Table 8.A which acts as a quick locator alphabetized listing.) It is strongly recommended that **all** the setpoints be determined, recorded and verified **before** any entry is begun. For assistance, a Set Point Record Sheet is included to act as a permanent record of the set point values for an individual application (see Table 8.B). Copies of it should be made and stored in a number of locations, including the enclosure containing the IQ-1000 II.

Not all setpoint functions and associated values or settings may be required by a given IQ-1000 II application. In such cases, make one of the following notations on the Record Sheet.

- Place N/A or some other notation in the space if the function/value has no effect on operation. (For example, winding temperature, when there is no RTD Module.)
- Write in the value required to disable the function. (Specific instructions on disabling set point functions are given in the following descriptions.)

A copy of a correctly filled-in Set Point Record Sheet must be given to the individual responsible for value entry. The IQ-1000 II displays its setpoint functions in a fixed sequence that is duplicated on the Set Point Record Sheet. Thus, the sheet minimizes programming time. (Specific entry procedures are described in Paragraph 4.3.)

### NOTE

Unless specifically stated otherwise, it can be assumed that when operating conditions are greater than the user-selected setpoint, the function is initiated.

**8.1 Start and Run Delays** — Start and run delays are used with many of the protection functions of the IQ-1000 II to aid in starting and keeping the motor running. Attention should be paid to the units of different delays due to the varying requirements for different types of protection.

**8.1.1 Start Delays** — Start delays (start lockout delays) disable their related protection functions to prevent transient motor conditions during the motor inrush period from creating a trip.

All start delays are tied to the transition cycle in one respect **only**. The beginning of most start delays are initiated by the IQ-1000 II declaring a start; the only exceptions are the instantaneous overcurrent and ground fault functions which react in line cycles instead of seconds. Once a start is declared, start delays may time out before or after the IQ-1000 II has transitioned to the run state depending on the type of protection. If a trip condition during a start is maintained past the end

of the start delay, a trip may occur, never allowing the IQ-1000 II to transition to the run mode. See section 7.2 for a description of start, run and stop cycles.

The start delays provided in the IQ-1000 II are as follows:

- Ground Fault Start Delay — in line cycles
- Instantaneous Overcurrent Start Delay — in line cycles
- Jam Start Delay — in seconds
- Underload Start Delay — in seconds

**8.1.2 Run Delays** — Run delays are used to provide a time-based filter on transient trip conditions which might cause nuisance tripping.

The run delay is initiated by a transient trip condition occurring after the associated start delay has timed out. Once the run delay has begun, the trip condition must be maintained for the full length of the run delay. If at any time the condition goes away and then returns, the run delay is reset. The trip condition must remain present for the full length of the run delay time to initiate a trip.

The fastest response for a function with both start and run delays is found by adding the two programmed delays together. This would be the response time if the trip condition were detected at any point during the start delay.

The run delays provided in the IQ-1000 II are as follows:

- Ground Fault Run Delay — in cycles
- Jam Run Delay — in seconds
- Underload Run Delay — in seconds
- Phase Unbalance Alarm Run Delay — in seconds

**8.2 Setpoint Item 1, Operating Modes** — One of two different operating modes may be selected by the user. One mode is used when the IQ-1000 II is protecting a motor or being tested using a three-phase current source. A second mode is used when the IQ-1000 II is being tested or programmed using a single-phase current source.

In all cases where three-phase current is being monitored by the IQ-1000 II, the three-phase mode must be selected. The three-phase mode is displayed in the Program mode as:

3 PHASE

When in the Program mode, pressing either the Raise or Lower pushbutton causes the display to toggle between "3 PHASE" and "1 PHASE" messages.

In cases where the IQ-1000 II is to be tested, and the only available test method is using a single-phase current source, then the single-phase test mode must be selected. The single-phase test mode is displayed in the Program mode as:

## 1 PHASE

When the single-phase test mode is selected, most of the IQ-1000 II protective features can be tested. The Phase Unbalance alarm and trip features, however, can only be tested with a three-phase current source. In single-phase test mode, the phase unbalance protection feature is disabled.

When the operating mode function is displayed, it will toggle between the following two messages:

3 PHASE      1 PHASE

This menu item is numbered 1 in Table 8.B.

**8.3 Setpoint Item 2, RTD Monitoring** — Assuming that optional RTDs are used, and the optional RTD Module is installed, the IQ-1000 II is capable of monitoring the operating temperatures at three key motor locations. Both trip and alarm setpoints are available for the three placement areas. These are the motor's:

- Stator windings
- Motor bearings
- Load bearings

If the optional RTD Module is not used with the IQ-1000 II, there is no need to enter these values.

If the RTD Module is installed with no RTDs connected, the IQ-1000 II will display a “-” for each RTD. This same display is used for shorted or open RTDs. However, all unused RTD Module terminals should be jumpered, as described in Paragraph 5.3.2. All valid RTD readings will display a numeric value.

**NOTE**

If an RTD Module is not connected or is connected improperly, all RTD information will be removed from the metering display.

Setpoint item 2 determines whether the temperatures displayed from the RTDs are in degrees F or degrees C. Pressing either the Raise or Lower pushbutton causes the display to toggle between the following messages:

RTD IN F  
RTD IN C

The temperature range displayed is from 32-390°F, and from 0-199°C. The IQ-1000 II software calculates all temperatures using degrees C and then displays the value in degrees C or degrees F, depending on setpoint item 2. When degrees C is selected, displayed RTD values are incremented in one degree steps. If degrees F is selected, RTD values increment in either one or two degree steps (this is due to rounding off the conversion calculations for display purposes; accuracy of the RTD setpoints is not affected).

**8.3.1 Setpoint Items 3 and 7, Stator Winding Temperature** —The IQ-1000 II is capable of monitoring the temperature of a motor's stator windings and using this data to determine the motor protection curve.

Table 8.A

**ALPHABETIZED FUNCTION LISTING**

Function	Paragraph
Anti-backspin delay	8.17
Auxiliary temperature (alarm)	8.3.4
Auxiliary temperature (trip)	8.3.4
Current transformer ratio	8.28
Differential trip on remote input	8.22
Frequency (50/60 Hz)	8.19
Full-load amperes	8.18
Ground fault run delay	8.4.3
Ground fault start delay	8.4.2
Ground fault trip level	8.4.1
Incomplete sequence	8.16
Instantaneous overcurrent enable/disable	8.5.1
Instantaneous overcurrent start delay	8.5.3
Instantaneous overcurrent % FLA	8.5.2
I <sup>2</sup> T alarm level	8.8
I <sup>2</sup> T reset	8.9
Jam alarm level	8.10.1
Jam run delay	8.10.4
Jam start delay	8.10.3
Jam trip level	8.10.2
Locked-rotor current	8.6.1
Locked-rotor time (stall time)	8.6.2
Load bearing temperature (alarm)	8.3.3
Load bearing temperature (trip)	8.3.3
Manual reset	8.9
Motor bearing temperature (alarm)	8.3.2
Motor bearing temperature (trip)	8.3.2
Motor stop on remote input	8.22
Operating modes	8.2
Operations count reset	8.14.3
Phase unbalance alarm	8.12.1
Phase unbalance run delay	8.12.2
Phase unbalance trip	8.13
Reset on remote input	8.22
Reset Disable	8.22
Reversing/Non-Reversing	8.21
Run time reset	8.14.4
Starts allowed	8.14.1
Time (for starts) allowed	8.14.2
Transition current level	8.15.1
Transition time	8.15.2
Trip/transition on time out	8.15.3
Trip relay mode 1	8.20.1
Trip relay mode 2	8.20.2
Trip on remote input	8.22
Ultimate trip	8.7
Underload alarm level	8.11.1
Underload run delay	8.11.4
Underload start delay	8.11.3
Underload trip level	8.11.2
Winding temperature (alarm)	8.3.1
Winding temperature (trip)	8.3.1

Individual setpoint values can be selected for both trip and alarm conditions. These settings apply to all winding RTDs. The function is displayed in the program menu as:

WD T xxx  
WD A xxx

Here the letters T and A represent trip and alarm, respectively. The letters xxx represent the user-chosen value. These program menu items are numbered 3 and 7 in Table 8.B.

The ranges of available setpoint values are:

Trip: 0-199°C / 32-390°F  
(in 1°C increments)  
Alarm: 0-199°C / 32-390°F  
(in 1°C increments)

**8.3.2 Setpoint Items 4 and 8, Motor Bearing Temperature** — The IQ-1000 II is capable of monitoring two motor bearing RTDs.

Individual setpoints can be selected and entered for both trip and alarm conditions. The function is displayed in the program menu as:

MB T xxx  
MB A xxx

Here the letters T and A represent trip and alarm, respectively. The letters xxx represent the user-chosen value. These menu items are numbered 4 and 8 in Table 8.B.

The ranges of available setpoint values are:

Trip: 0-199°C / 32-390°F  
(in 1°C increments)  
Alarm: 0-199°C / 32-390°F  
(in 1°C increments)

**8.3.3 Setpoint Items 5 and 9, Load Bearing Temperature** — The IQ-1000 II is capable of monitoring two of the motor's load bearing temperatures.

Individual setpoints can be selected and entered for both trip and alarm conditions. The function is displayed in the program menu as:

LB T xxx  
LB A xxx

Here the letters T and A represent trip and alarm, respectively. The letters xxx represent the user-chosen value. These menu items are numbered 5 and 9 in Table 8.B.

The ranges of available setpoint values are:

Trip: 0-199°C / 32-390°F  
(in 1°C increments)  
Alarm: 0-199°C / 32-390°F  
(in 1°C increments)

**8.3.4 Setpoint Items 6 and 10, Auxiliary Temperature** — The IQ-1000 II is capable of monitoring one auxiliary temperature.

Individual setpoints can be selected and entered for both trip and alarm conditions. The function is displayed in the program menu as:

AX T xxx  
AX A xxx

Here the letters T and A represent trip and alarm, respectively. The letters xxx represent the user-chosen value. These menu items are numbered 6 and 10 in Table 8.B.

The ranges of available setpoint values are:

Trip: 0-199°C / 32-390°F  
(in 1°C increments)  
Alarm: 0-199°C / 32-390°F  
(in 1°C increments)

The auxiliary RTD can be used to monitor a separate temperature, such as motor case temperature.

**8.4 Ground Fault** — The IQ-1000 II's ground fault function provides protection against excessive ground leakage currents. Use of this function requires an external 50:5 ground fault current transformer to be installed in the application. The turns ratio assumed by the IQ-1000 II is always 50:5. This setpoint function can only be applied to a grounded system, as described in Paragraph 7.1.6.

There are three distinct setpoints associated with this function. These are:

- Trip level (in primary amperes)
- Start delay (in cycles)
- Run delay (in cycles)

Assuming a ground fault transformer is being used, all three of these setpoint functions must be "used" in the IQ-1000 II. The delay functions can be defeated by setting the start delay to 1 line cycle and the run delay to 0 line cycles. If no ground fault current transformer is connected, these setpoints are ignored and no ground fault protection is provided.

#### NOTE

If the run delay is set to 0, trips may occur at a lower current level than specified due to the sampling used in maintaining the high speed response of this function.

**8.4.1 Setpoint Item 11, Ground Fault Trip Level** — The IQ-1000 II has a selectable ground fault trip level above which a trip will occur after the specified start and run delays. The set point is defined in amperes. The ground fault trip level is displayed in the program menu as:

GF xx

Here the letters xx represent the user-determined current level above which a trip condition occurs. This menu item is numbered 11 in Table 8.B.

The range of available setpoint values is:

Trip: 1-12 amperes  
(in 1 ampere increments)

**8.4.2 Setpoint Item 12, Ground Fault Start Delay** — The IQ-1000 II provides a start lockout delay to allow the ground current that can be generated by power factor correction capacitors during starting to clear. The application of a start delay is described in Paragraph 8.1.1.

The ground fault start delay function is displayed in the program menu as:

GFSD xx

Here the letters xx represent the user-determined delay, which, when reached, allows a trip condition to be initiated. This menu item is numbered 12 in Table 8.B.

The range of available set point values is:

Start delay: 1-20 AC line cycles  
(in 1 cycle increments)

**8.4.3 Setpoint Item 13, Ground Fault Run Delay** — The IQ-1000 II provides a run delay to prevent momentary disturbances in the system from causing a nuisance trip. The application of a run delay is described in Paragraph 8.1.2.

The ground fault run delay function is displayed in the program menu as:

GFRD xx

Here the letters xx represent the user-determined delay, which, when reached, allows the trip condition. This menu item is numbered 13 in Table 8.B.

The range of available setpoint values is:

Run delay: 0-10 AC line cycles  
(in 1 cycle increments)

\*\* Disable setting for GFRD — 0 cycle \*\*

**8.5 Instantaneous Overcurrent Protection** — The IQ-1000 II's instantaneous overcurrent function monitors motor current on a continuous basis. It requires no more than two line cycles to detect a trip condition. Because of the magnitudes of current that can be seen in an instantaneous overcurrent, no run delay is provided.

There are three distinct setpoints associated with this function. These are:

- Instantaneous overcurrent enable/disable
- Instantaneous overcurrent trip level (in percent of **peak** full-load amperes)
- Instantaneous overcurrent start delay (in cycles)

(Paragraph 7.1.3.1 details those application conditions involved in selecting the appropriate value.)

**8.5.1 Setpoint Item 14, Instantaneous Overcurrent Enable/Disable** — The instantaneous overcurrent (IOC) can be disabled for applications where current in excess of 1600% of full-load amps can occur in normal operation.

The display will toggle between the following two messages:

IOC ON      IOC OFF

If the IOC OFF message is displayed when leaving Program mode, the IOC set points will be ignored and an IOC trip will never be acknowledged. This menu item is numbered 14 in Table 8.B.

**8.5.2 Setpoint Item 15, Instantaneous Overcurrent Trip**

NOTE

When IOC OFF is selected, the IOC trip level (menu item 15) and IOC start delay value (menu item 16) will have a “-” displayed next to them in the Program Display.

**Level in % Full-load Amperes** — The IQ-1000 II provides an instantaneous overcurrent trip level in percent of the **peak** full-load amps. This provides the fastest response possible when a fault condition occurs.

NOTE

The chosen setpoint value **must** be equal to, or higher, than 1.6 times the locked-rotor current ratio (provided by the motor manufacturer).

NOTE

For the IOC trip level to be effective, set it below your fuse interrupting rating *or* your contactor withstand rating.

The instantaneous overcurrent function, in percent of full-load amperes, is displayed in the program menu as:

IOC xxxx

Here the letters xxxx represent the user-determined level, which, when reached, allows a trip condition. This menu item is numbered 15 in Table 8.B.

The range of available setpoint values is:

Trip: 300-1600%  
of full-load amperes  
(in 1% increments)

NOTE

When IOC OFF (setpoint item 14) is selected, the IOC trip level will have a “-” displayed next to it in the Program Display.

NOTE

When IOC trips occur, the displayed metered values will normally not reflect the actual fault current. This is due to the averaging used to calculate the display value.

**8.5.3 Setpoint Item 16, Instantaneous Overcurrent Start Delay** — The IQ-1000 II provides a start delay to allow the unit to ride through the first cycles of inrush current during starting. The application of a start delay is described in Paragraph 8.1.1. (For more details on the motor's start and stop cycles, refer to Paragraph 7.2.)

The instantaneous overcurrent start delay setpoint function is displayed in the program menu as:

IOCSD xx

Here the letters xx represent the user-determined delay.

This menu item is numbered 16 in Table 8.B.

The range of available setpoint values is:

Delay: 1-20 AC line cycles  
(in 1 cycle increments)

**8.6 Locked-Rotor Protection** — Two IQ-1000 II functions operate together to specify a point on the motor damage curve. These trip condition components are:

- Locked-rotor current (in percent of full-load amperes)
- Locked-rotor time or stall time (in seconds)

This current level and time, when reached, create a locked-rotor trip condition

(More information on how these setpoint functions affect the motor protection curve is contained in Paragraphs 7.1.3.2 and 7.1.4.)

**NOTE**

The locked-rotor current and the maximum allowable stall time values must be obtained from the motor manufacturer.

**CAUTION**

The rotor temperature protection algorithm uses the locked-rotor current and the maximum allowable stall time values to calculate the rotor protection curve. Incorrectly chosen set point values for these functions can result in excessive rotor temperatures and eventual motor damage.

**8.6.1 Setpoint Item 17, Locked-Rotor Current** — The locked-rotor current value specified by the motor manufacturer is the current a motor will draw if the rotor is stalled. This set point along with the stall time defines the thermal capacity of the motor.

The locked-rotor current function is displayed in the program menu as:

LRC xxxx

Here the letters xxxx represent the level determined by the motor manufacturer. This menu item is numbered 17 in Table 8.B.

The range of available setpoint values is:

Current: 300-1200%  
of full-load amperes  
(in 1% increments)

**8.6.2 Setpoint Item 18, Locked-Rotor Time (Stall Time)** —

The maximum allowable stall time function specifies the amount of time a locked-rotor condition can be maintained before damage is done to the motor. This value is supplied by the manufacturer and is used in conjunction with the locked-rotor current.

The stall time setpoint function is displayed in the program menu as:

LRT xx

Here the letters xx represent the maximum allowable time determined by the motor manufacturer. This menu item is

numbered 18 in Table 8.B. The range of available setpoint values is:

Time: 1-60 seconds  
(in 1 second increments)

**8.7 Setpoint Item 19, Ultimate Trip** — The ultimate trip function defines the current level above which a trip will eventually happen. This value represents an asymptotic line on the motor damage curve below which the motor will never be damaged.

This setpoint is used when RTDs are not employed to define the level above which the I<sup>2</sup>T accumulator will start to migrate toward a trip. If a service factor is supplied with the motor, it can be multiplied times the full-load amp rating to give the maximum ultimate trip level. For example, a motor with a 1.25 service factor can use an ultimate trip level of 125 percent of full load. (Paragraph 7.1.3.3 describes application considerations related to value selection.)

Some possible reasons for using a conservative approach to set the ultimate trip below 100% are:

- When ambient temperatures above 40°C are anticipated and the optional RTD Module is **not** used in the application. (Environmental temperature considerations are discussed in Paragraph 7.1.3.6.)
- When the motor is properly rated, yet additional safety is critical for the application.

**CAUTION**

If the ultimate trip set point value is **above** 100% and the motor does **not** have a service factor rating higher than 1, motor damage can result.

The ultimate trip function is displayed in the program menu as:

UTC xxx

Here the letters xxx represent the user-determined percent of full-load amperes for the ultimate trip level. This menu item is numbered 19 in Table 8.B.

The range of available setpoint values is:

Trip: 85-125%  
of full-load amperes  
(in 1% increments)

**8.8 Setpoint Item 20, I<sup>2</sup>T Alarm** — The I<sup>2</sup>T alarm function refers to the current-squared multiplied-by-time algorithm discussed at Paragraph 3.2.2. The accumulated I<sup>2</sup>T is directly proportional to the rotor temperature. The I<sup>2</sup>T trip is a level selected in percent of the I<sup>2</sup>T trip value. This gives the user some idea of how close to a trip the IQ-1000 II is since the I<sup>2</sup>T trip point is derived from the programmed motor parameters and maintained internally. (The maximum rotor temperature trip point is explained in Section 3.)

This function also determines when the I<sup>2</sup>T trip condition can be reset, as described in Paragraph 8.9. The closer to 100% the alarm is set, the sooner the motor can be restarted; however, the motor inrush may create another trip if the motor has not been allowed to cool.

The I<sup>2</sup>T alarm function is displayed in the program menu as:

I<sup>2</sup>TA xxx

Here the letters xxx represent the user-entered percent, at which level the alarm condition is initiated. This menu item is numbered 20 in Table 8.B.

The range of available setpoint values is:

Alarm: 60-100%  
of the I<sup>2</sup>T trip level  
(in 1% increments)

\*\* Disable setting for I<sup>2</sup>TA — 100% of trip \*\*

The I<sup>2</sup>T alarm level is explained on the Help screen as I<sup>2</sup>T ALARM LEVEL IN % I<sup>2</sup>T TRIP. The actual trip level is calculated by the IQ-1000 II internally, as discussed in Paragraph 3.2.2.

#### NOTE

The I<sup>2</sup>T accumulator is cleared every time the IQ-1000 II is placed in Program mode. This can be used to clear an I<sup>2</sup>T trip without waiting for the motor to cool.

**8.9 Setpoint Item 21, I<sup>2</sup>T Reset Function** — The reset function allows either manual or automatic resetting from a locked rotor or an I<sup>2</sup>T trip. In the automatic mode, the IQ-1000 II will reset an I<sup>2</sup>T trip after the I<sup>2</sup>T accumulator has cooled below the I<sup>2</sup>T alarm level discussed in Paragraph 8.8 or is cleared in Program mode.

In the manual mode, an I<sup>2</sup>T trip must be reset by the user in one of three ways **after** the I<sup>2</sup>T accumulator has cooled below the I<sup>2</sup>T alarm level. One is to push the Reset button on the IQ-1000 II operator's panel. The second is to set the remote input setpoint to the reset mode (menu item 46) and apply 120 VAC across terminals 8 and 9 on the back of the IQ-1000 II. The third way to reset an I<sup>2</sup>T trip is to issue a command over the communications port from a host computer.

With this function, either MAN RST or AUTO RST **must** be selected for every application. Pressing either the Raise or Lower pushbutton causes the display to toggle between the two following messages:

MAN RST      AUTO RST

This menu item is numbered 21 in Table 8.B.

**8.10 Jam Functions** — The IQ-1000 II provides a jam function for initiating an alarm or a trip for mechanical failures in a driven load. (More information on the jam functions is given in Paragraph 7.1.3.5.)

There are four distinct setpoints associated with the jam function. These are:

- Alarm level ( in % FLA)
- Trip level (in % FLA)
- Start delay (in seconds)
- Run delay (in seconds)

**8.10.1 Setpoint Item 22, Jam Alarm Level** — The jam alarm level set point function specifies the current level above which an alarm condition is initiated (this level is measured as a percent of full-load amperes).

The jam alarm level setpoint function is displayed in the program menu as:

JMA xxxx

Here the letters xxxx represent the user-entered percent of full-load amperes. This menu item is numbered 22 in Table 8.B.

The range of available setpoint values is:

Alarm: 100-1200%  
of full-load amperes  
(in 1% increments)

\*\* Disable setting for JMA — 1200% \*\*

If the jam alarm level is not disabled, it should be set at a value below the jam trip level (setpoint item 23).

**8.10.2 Setpoint Item 23, Jam Trip Level** — The jam trip level set point function specifies the current level above which a trip condition is initiated (this level is measured as a percent of full-load amperes).

The jam trip level setpoint function is displayed in the program menu as:

JMT xxxx

Here the letters xxxx represent the user-entered percent of full-load amperes. This menu item is numbered 23 in Table 8.B.

The range of available setpoint values is:

Trip: 100-1200%  
of full-load amperes  
(in 1% increments)

\*\* Disable setting for JMT — 1200% \*\*

**8.10.3 Setpoint Item 24, Jam Start Delay** — The IQ-1000 II provides a start delay to allow high inertia loads to be accelerated over a long period of time without a nuisance trip. The application of a start delay is described in Paragraph 8.1.1. The jam start delay function is displayed in the program menu as:

JAMS xx

Here the letters xx represent the number of seconds selected to block out the jam function. This menu item is numbered 24 in Table 8.B.

The range of available setpoint values is:

Start delay: 0-60 seconds  
(in 1 second increments)

\*\* Disable setting for JAMS — 0 seconds \*\*

**8.10.4 Setpoint Item 25, Jam Run Delay** — The IQ-1000 II provides a jam run delay to allow for heavy loads which are loaded and unloaded, such as a conveyer belt drive. The application of a run delay is described in Paragraph 8.1.2.

The jam run delay function is displayed in the program menu as:

JAMR xxx

Here the letters xxx represent the user-selected delay, at which time the trip occurs. This menu item is numbered 25 in Table 8.B.

**Table 8.B**  
**SET POINT RECORD SHEET**

Program Date \_\_\_\_\_ Control Schematic \_\_\_\_\_  
 Unit ID/Starter Type \_\_\_\_\_ W. Order # \_\_\_\_\_  
 Motor HP \_\_\_\_\_ Mfr. \_\_\_\_\_ Serial \_\_\_\_\_ Volts \_\_\_\_\_  
 FLA \_\_\_\_\_ LRA \_\_\_\_\_ Stall Time \_\_\_\_\_ Accel Time \_\_\_\_\_  
 SF \_\_\_\_\_ RTD Type \_\_\_\_\_ Other \_\_\_\_\_

Item No.	Program Menu Display <sup>1,2</sup>	Selected Value	Set Point Ranges Selection	Set Point Disable Value
0	S VER XX SOFTWARE VERSION NUMBER <sup>3</sup>	N/A	N/A	
1	X PHASE SINGLE PHASE TEST MODE OR THREE PHASE PROTECTION MODE		Toggles between 1 PHASE and 3 PHASE	
2	RTD IN X RTD TEMP IN DEGREES F OR DEGREES C		Toggles between RTD IN F and RTD IN C	
3	WD T XXX WINDING TEMP TRIP IN DEGREES		0-199°C / 32-390°F (1° incre.)	
4	MB T XXX MOTOR BEARING TRIP IN DEGREES		0-199°C / 32-390°F (1° incre.)	
5	LB T XXX LOAD BEARING TRIP IN DEGREES		0-199°C / 32-390°F (1° incre.)	
6	AX T XXX AUXILIARY TRIP IN DEGREES		0-199°C / 32-390°F (1° incre.)	
7	WD A XXX WINDING TEMP ALARM IN DEGREES		0-199°C / 32-390°F (1° incre.)	
8	MB A XXX MOTOR BEARING ALARM IN DEGREES		0-199°C / 32-390°F (1° incre.)	
9	LB A XXX LOAD BEARING ALARM IN DEGREES		0-199°C / 32-390°F (1° incre.)	
10	AX A XXX AUXILIARY ALARM IN DEGREES		0-199°C / 32-390°F (1° incre.)	
11	GF XX GROUND FAULT TRIP LEVEL IN AMPS		1-12 amps (1 amp. incre.)	12
12	GFSD XX GROUND FAULT START DELAY IN CYCLES		1-20 AC cycles (1 cycle incre.)	
13	GFRD XX GROUND FAULT RUN DELAY IN CYCLES		0-10 AC cycles (1 cycle incre.)	0
14	IOC XX ENABLE OR DISABLE INSTANTANEOUS OVERCURRENT FUNCTION		Toggles between IOC ON and IOC OFF displays	IOC OFF
15	IOC XXXX INSTANTANEOUS OVERCURRENT IN % FLA <sup>5</sup>		300-1600% (1% incre.)	

**Table 8.B**  
**SET POINT RECORD SHEET**  
**(Cont'd)**

Item No.	Program Menu Display <sup>1,2</sup>	Selected Value	Set Point Ranges Selection	Set Point Disable Value
16	IOCSD XX INSTANTANEOUS OVERCURRENT START DELAY IN CYCLES		1-20 cycles (1 cycle incre.)	
17	LRC XXXX LOCKED ROTOR CURRENT IN % FLA		300 to 1200% (1% incre.)	
18	LRT XX MAXIMUM ALLOWABLE STALL TIME IN SECONDS		1-60 sec. (1 sec. incre.)	
19	UTC XXX ULTIMATE TRIP CURRENT IN % FLA		85-125% (1% incre.)	
20	I <sup>2</sup> T <sup>A</sup> XXX I <sup>2</sup> T ALARM LEVEL IN % I <sup>2</sup> T TRIP		60-100% (1% incre.)	100
21	MAN RST <sup>4</sup> AUTO RST <sup>4</sup> AUTO OR MANUAL I <sup>2</sup> T RESET		Toggles between MAN RST and AUTO RST displays	
22	JM A XXXX JAM ALARM LEVEL IN % FLA		100-1200% (1% incre.)	1200
23	JM T XXXX JAM TRIP LEVEL IN % FLA		100-1200% (1% incre.)	1200 <sup>6</sup>
24	JAMS XX JAM START DELAY IN SECONDS		0-60 sec. (1 sec. incre.)	
25	JAMR XXX JAM RUN DELAY IN SECONDS		0-240 sec. (1 sec. incre.)	240
26	UL A XX UNDERLOAD ALARM LEVEL IN % FLA		0-90% (1% incre.)	0
27	UL T XX UNDERLOAD TRIP LEVEL IN % FLA		0-90% (1% incre.)	0
28	ULSD XXX UNDERLOAD START DELAY IN SECONDS		0-100 sec. (1 sec. incre.)	
29	ULRD XX UNDERLOAD RUN DELAY IN SECONDS		1-10 sec. (1 sec. incre.)	1
30	PU A XX PHASE UNBALANCE ALARM LEVEL		10-50% (1% incre.)	50 <sup>6</sup>
31	PURD XXX PHASE UNBALANCE ALARM RUN DELAY IN SECONDS		0-240 sec. (1 sec. incre.)	
32	I <sup>2</sup> T TRIP <sup>4</sup> 2 SEC <sup>4</sup> 2 SECOND DELAY OR I <sup>2</sup> T TRIP ON PHASE UNBALANCE		Toggles between I <sup>2</sup> T TRIP and 2 SEC displays	
33	ST/T XX STARTS PER TIME ALLOWED		1-10 starts/ time (incre. of 1)	1

**Table 8.B**  
**SET POINT RECORD SHEET**  
 (Cont'd)

Item No.	Program Menu Display <sup>1,2</sup>	Selected Value	Set Point Ranges Selection	Set Point Disable Value
34	T/ST X TIME ALLOWED FOR STARTS COUNT IN MINUTES		0 to 240 minutes duration (1 minute incre.)	0
35	OP COUNT <sup>4</sup> RST OCNT <sup>4</sup> RESET FOR OPERATIONS COUNTER		Toggles between OP COUNT and RST OCNT	OP COUNT
36	RUN TIME <sup>4</sup> RST RT <sup>4</sup> RESET FOR RUN TIME		Toggles between RUN TIME and RST RT displays	RUN TIME
37	TRNC XXX MOTOR START TRANSITION CURRENT LEVEL IN % FLA		50-150% (1% incre.)	150
38	TRNT XXX MOTOR START TRANSITION TIME IN SECONDS		0-240 sec. (1 sec. incre.)	0
39	TRN TOUT <sup>4</sup> TRP TOUT <sup>4</sup> TRANSITION OR TRIP ON TIME OUT		Toggles between TRN TOUT and TRP TOUTdisplays	TRN TOUT
40	INSQ XX INCOMPLETE SEQUENCE REPORT BACK TIME IN SECONDS		1-60 sec. (1 sec. incre.)	
41	ABKS XXX ANTI-BACKSPIN DELAY TIME IN SECONDS		0-600 sec.	0
42	FLA XXXX FULL-LOAD AMPS		10-3000 amps (1 amp incre.)	
43	FREQ 50 <sup>4</sup> FREQ 60 <sup>4</sup> 50 OR 60 HERTZ LINE FREQUENCY		Toggles between FREQ 50 and FREQ 60 displays	
44	MODE 1 <sup>4</sup> MODE 2 <sup>4</sup> TRIP MODE 1 — TRIP RELAY ENERGIZES ON TRIP CONDITION <sup>4</sup> TRIP MODE 2 — TRIP RELAY ENERGIZES ON POWER UP AND DE-ENERGIZES ON TRIP CONDITION <sup>4</sup>		Toggles between MODE 1 and MODE 2	
45	NON REV <sup>4</sup> REV <sup>4</sup> REVERSING OR NONREVERSING STARTER		Toggles between REV and NONREV displays	

**Table 8.B**  
**SET POINT RECORD SHEET**  
 (Cont'd)

Item No.	Program Menu Display <sup>1,2</sup>	Selected Value	Set Point Ranges Selection	Set Point Disable Value
46	REM RST <sup>4</sup> REM TRIP <sup>4</sup> DIF TRIP <sup>4</sup> MTR STOP <sup>4</sup> RST DBL <sup>4</sup> REMOTE INPUT — RST FOR REMOTE RESET — TRIP FOR REMOTE TRIP — DIF TRIP FOR DIFFERENTIAL TRIP — MTR STOP FOR MOTOR STOP DETECTION — RST DBL FOR RESET DISABLE		Toggles between REM TRIP, REM RST, DIF TRIP, MTR STOP	
47	MAX XXX <sup>4</sup> 4-20 MA MAX OUTPUT — 100 FOR 100 PERCENT FLA — 125 FOR 125 PERCENT FLA — %I2T FOR PERCENT I2T TRIP — WRD FOR MAXIMUM WINDING RTD TEMP		Toggles between MAX100, MAX125. MAX%I2T and MAXWRD displays	
48	AUX XXXX TRIP STATE FOR AUX TRIP RELAY		Toggles between ALL, IOC, I2T, GFLT, JAM, UL, MBT, LBT, WT and REV displays <sup>4</sup>	
49	TRIP XXX RESET FOR NUMBER OF TRIPS		Toggles between TRIP CNT and TRIP RST displays <sup>4</sup>	TRIP CNT
50	MAX XXX RESET FOR MAXIMUM VALUES		Toggles between MX R-EBL, MX RESET and MX R-DBL displays <sup>4</sup>	MX R-DBL
51	XXX PGM ENABLE UNIT TO BE PROGRAMMED WHILE MOTOR IS RUNNING		Toggles between RUN PGM and STOP PGM	
52	X/5 XXXX CT RATIO — X TURNS TO 5		Available CT turns:5 ratios are: 10, 20, 25, 40, 50, 75, 100, 125, 150, 200, 250, 300, 400, 500, 600, 800, 1000, 1200, 1500, 2000, 2500, 3000, 4000	

## NOTES:

- The letters X used here represent the setpoint variables.
- Press the Help pushbutton to initiate the help display of the complete message shown here. The display scrolls right to left.
- The software version number is used by Westinghouse. There is no selection associated with it. All correspondence with Westinghouse should refer to the specific software version number installed in the IQ-1000 II.
- One of these choices must be selected.
- IOC trip setting should be lower than your Fuse Interrupting Rating or your Contactor Withstand Rating.
- Set start and run delays to maximum values to disable trip/alarm functions.

The range of available setpoint values is:

Run delay: 0- 240 seconds  
(in 1 second increments)

**8.11 Underload Functions** — The IQ-1000 II's underload functions initiate an alarm or a trip condition if the motor's driven load drops **below** a selected value for a selected time. (More information about underload is given in Paragraph 7.1.3.4.)

There are four distinct setpoints associated with the underload function. These are:

- Alarm level (in % FLA)
- Trip level (in % FLA)
- Start delay (in seconds)
- Run delay (in seconds)

**8.11.1 Setpoint Item 26, Underload Alarm Level** — The underload alarm level function specifies the current level at which the IQ-1000 II alarm contacts change state because of a reduced current.

The underload alarm level setpoint function is displayed in the program menu as:

ULA xx

Here the letters xx represent the alarm level in percent of full-load amperes. This menu item is numbered 26 in Table 8.B.

The range of available setpoint values is:

Alarm: 0-90%  
of full-load amperes  
(in 1% increments)

\*\* Disable value for ULA — 0% of full-load amps \*\*

If the underload alarm level is not disabled, it should be set at a value above the underload trip level (setpoint item 27).

For example, if the underload trip level is set at 80% of full load amperes, the underload alarm level should be set to some value between 81% to 90% of full load amperes. This ensures that an alarm indication will be present before a trip condition is reached.

**8.11.2 Setpoint Item 27, Underload Trip Level** — The underload trip level function specifies the current level at which the IQ-1000 II assumes the motor lost its load and trips the motor off line.

The underload trip level setpoint function is displayed in the program menu as:

ULT xx

Here the letters xx represent the trip level in percent of full-load amperes. This menu item is numbered 27 in Table 8.B.

The range of available setpoint values is:

Trip: 0-90%  
of full-load amperes  
(in 1% increments)

\*\* Disable value for ULT — 0% of full-load amps \*\*

**8.11.3 Setpoint Item 28, Underload Start Delay** — The IQ-1000 II provides a start delay to allow a motor to be started while unloaded and to reach full speed before the load is applied. The application of a start delay is described in Paragraph 8.1.1.

The underload start delay function is displayed in the program menu as:

ULSD xxx

Here the letters xxx represent the user-selected delay, at which time the trip occurs. This menu item is numbered 28 in Table 8.B.

The range of available setpoint values is:

Delay: 0-100 seconds  
(in 1 second increments)

**8.11.4 Setpoint Item 29, Underload Run Delay** — The IQ-1000 II provides a run delay for varying loads such as a power factor corrected motor which is run at very light loads intermittently. The application of a run delay is discussed in Paragraph 8.1.2.

The underload run delay function is displayed in the program menu as:

ULRD xx

Here the letters xx represent the underload run delay. This menu item is numbered 29 in Table 8.B.

The range of available setpoint values is:

Run delay: 1-10 seconds  
(in 1 second increments)

**8.12 Phase Unbalance Functions** — The IQ-1000 II's phase unbalance functions monitor the AC line for a possible phase unbalance condition of the actual motor currents.

There are two distinct setpoints associated with this function. These are:

- Alarm level (in % unbalance)
- Run delay (in seconds)

Exceeding these two setpoints, however, does not cause a trip condition. (The functions described in Paragraph 8.13 control the phase unbalance trip condition.)

(Keep in mind that unbalance-detection factors are also incorporated into the I<sup>2</sup>T protection algorithm. Should the calculated negative sequence current become too high due to a combination of excessively high current levels and/or a phase unbalance condition, the IQ-1000 II will trip as a locked-rotor trip.)

**8.12.1 Setpoint Item 30, Phase Unbalance Alarm Level** — The phase unbalance alarm level specifies the point where an out-of-balance phase condition initiates an alarm condition. The alarm level is in percent of unbalance, calculated by comparing the ratio of the negative sequence current to the positive sequence current (see Paragraph 3.2.2 for more details). If the negative sequence is 10% of the positive sequence, there is a 10% unbalance between  $I_A$ ,  $I_B$ , and  $I_C$ .

The phase unbalance alarm setpoint function is displayed in the program menu as:

PU A xx

Here the letters xx represent the phase unbalance alarm level above which an alarm condition exists. This menu item is numbered 30 in Table 8.B.

The range of available setpoint values is:

Alarm: 10%-50%  
of unbalance  
(in 1% increments)

\*\* Disable setting for PU A — 50% unbalance \*\*  
(Same level as a phase loss trip; see Paragraph 8.13.)

**NOTE**

If a phase unbalance alarm is active and the unbalance condition is removed, the alarm is reset automatically.

**8.12.2 Setpoint Item 31, Phase Unbalance Alarm Run Delay** — The IQ-1000 II provides a run delay to allow for power system voltage variations which could cause short term unbalance conditions. The application of a run delay is described in Paragraph 8.1.2.

The phase unbalance alarm run delay function is displayed in the program menu as:

PURD xxx

Here the letters xxx represent the user-selected delay, at which time the alarm is initiated. This menu item is numbered 31 in Table 8.B.

The range of available setpoint values is:

Delay: 0-240 seconds  
(in 1 second increments)

**8.13 Setpoint Item 32, Trip/Delay Phase Unbalance Function** — A phase unbalance trip condition is defined as the negative sequence being equal to half of the positive sequence or a 50% phase unbalance (see Section 3 for more details).

The phase unbalance protection function provides a choice between (1) initiating a trip 2 seconds after the phase unbalance level is reached and (2) disabling this function to wait on an I<sup>2</sup>T trip. The set 2-second delay on phase unbalance is necessary to prevent nuisance tripping associated with momentary disturbances in the system.

Waiting on the I<sup>2</sup>T trip allows the motor to run until the last possible minute before tripping for critical applications where the motor must keep running as long as possible. One such application would be a chemical process which, if stopped, would ruin the material in the process.

With this function, one of these two choices **must** be selected for every application. Pressing either the Raise or Lower pushbutton causes the display to toggle between the two following messages:

I<sup>2</sup>T TRIP    2 SEC

This menu item is numbered 32 in Table 8.B.

**8.14 Starts, Time Functions** — Two separate setpoint functions control the number of motor starts allowed within a given period of time. These are:

- Starts (number of starts per time period allowed)
- Time period allowed (for those starts)

Should the user-specified number of motor starts exceed the set point within the specified time period, any further start cycles are prevented until the oldest start is returned.

These functions must be “used” in the sense that the user must always make a set point entry for both. However, by following the procedures described below, they can, in effect, be disabled.

**NOTE**

The number of starts is cleared every time the IQ-1000 II is placed in the Program mode. This can be used to clear a starts/exceeded trip.

**8.14.1 Setpoint Item 33, Starts Allowed** — The starts (per time) allowed setpoint function specifies the maximum number of motor starts permitted (within a given period). If this set point is reached, an alarm condition will appear with the message “STEX XXX” on the display. STEX stands for “starts exceeded” and the XXX is the number of minutes the user must wait before the oldest start is restored. If the motor is stopped while this message is on the screen, the alarm will become a trip and the motor cannot be started until the oldest start is returned.

All starts, including aborted starts, are counted by this function.

The starts allowed setpoint function is displayed in the program menu as:

ST/T xx

Here the letters xx represent the user-selected maximum number of allowed starts. This menu item is numbered 33 in Table 8.B.

The range of available setpoint values is:

Starts: 1-10 starts  
(within the time period)

This function can be indirectly disabled, thereby permitting an unlimited number of starts (see Paragraph 8.14.2 for details). If this function is indirectly disabled, any entry (1 thru 10) would be acceptable.

**8.14.2 Setpoint Item 34, Time Allowed** — The time allowed (for starts) setpoint function specifies the duration in which the maximum number of starts may occur. Each start has a “life span” equal to the time allowed setpoint. This means every start that is used will not be returned until it has been logged for the duration of this setpoint. This function works like a sliding window and will return starts in the same pattern they were used.

The setpoint is programmed in minutes in the Program mode. In the Protection mode, the display indicates the minutes remaining in the time period.

The time allowed setpoint function is displayed in the program menu as:

## T/ST x

Here the letter x represents the user-selected time period in which the maximum number of starts is allowed. This menu item is numbered 34 in Table 8.B.

The range of available setpoint values is:

Time: 0-240 minutes  
(in 1 minute increments)

\*\* Disable setting for T/ST — 0 minutes \*\*

By entering 0 minutes, the time allowed function is, in effect, disabled. Additionally, this entry disables the starts allowed function (item 33), thereby permitting an unlimited number of starts over any time period.

**NOTE**

When the time per allowed starts is set to 0, items 21 and 22 in Table 4.A will be displayed as “—” to denote this function is disabled.

**8.14.3 Setpoint Item 35, Operations Counter Reset** — The operations counter can be reset to zero while the IQ-1000 II is in the Program mode. If RST OCNT is the last message displayed while in Program mode, the operations counter will be set to zero when the keyswitch is placed in the Protection mode.

The display will toggle between the following two messages:

OP COUNT    RST OCNT

As an example, this feature is useful for resetting the operations count after preventive maintenance has been performed on the motor.

This menu item is numbered 35 in Table 8.B.

**8.14.4 Setpoint Item 36, Run Time Reset** — The run time can be reset to zero while the IQ-1000 II is in the Program mode. If RST RT is the last message displayed while in the Program mode, the run time will be set to zero when the keyswitch is placed in the Protection mode.

The display will toggle between the following two messages:

RUN TIME    RST RT

This feature is useful for resetting the run time after, for example, preventive maintenance has been performed on the motor.

This menu item is numbered 36 in Table 8.B.

**8.15 Motor Start Transition** — The IQ-1000 II provides a relay which can be set to energize on certain current levels or timing delays. User-programmed setpoints are required for the transition current level (item 37), the transition time (item 38), and action to take on transition time out (item 39). This transition relay can be used to control:

- Soft-start type motor starts
- Low- and high-voltage reduced voltage motor starters
- Any type of clutch between the motor and the driven load. (The clutch will be engaged after the motor attains the desired speed.)

**8.15.1 Setpoint Item 37, Motor Start Transition (Current Level)** — The motor start transition (current level) function specifies the current level below which the IQ-1000 II's transition relay will be energized. The current level is measured as a percent of full-load amperes.

The primary transition function is based on current. The transition time (item 38) is used as a backup in case the motor stalls during starting. When 30% of full load is detected in any phase by the IQ-1000 II, a start is declared. The normal inrush currents of a motor (even a solid-state starter with the voltage phased back) will exceed any of the allowable transition current levels immediately. If the current in any phase falls below the transition level within the transition time, the transition relay is energized and will remain so until a stop or trip condition occurs (see Figure 8.1). Once a start has occurred, the current must go above the transition level within 8 line cycles or an immediate transition may be initiated.

The motor start transition setpoint function is displayed in the program menu as:

TRNC xxx

Here the letters xxx represent the user-selected current level below which point the transition relay will be energized. This menu item is numbered 37 in Table 8.B.

The range of available setpoint values is:

Current: 50-150%  
of the full-load amperes rating  
(in 1% increments)

If the transition relay is not used, the transition current should be set to the maximum setting of 150%

**8.15.2 Setpoint Item 38, Motor Start Transition (Time)** — The motor start transition (time) specifies the maximum duration, in seconds, of the motor's start or transition cycle. The transition time is used as a backup timer only when the IQ-1000 II has not transitioned on current. If this happens, the IQ-1000 II will force a transition or create a transition trip depending on the trip/transition set point (item 39).

(For more details on the motor's start and run cycles, refer to Paragraph 7.2.)

The motor start transition (time) setpoint function is displayed in the program menu as:

TRNT xxx

Here the letters xxx represent the user-selected duration of the start or “transition” cycle. This menu item is numbered 38 in Table 8.B.

The range of available setpoint values is:

Time: 0-240 seconds  
(in 1 second increments)

\*\* Disable setting for TRNT — 0 seconds \*\*

If the transition relay is not used (as in across the line starts), the transition current (item 37) should be set to a maximum (150%) and the transition time to 0 seconds to force an immediate transition (see Figure 8.1). However, if the transition current setpoint is set to a minimum to force the IQ-1000

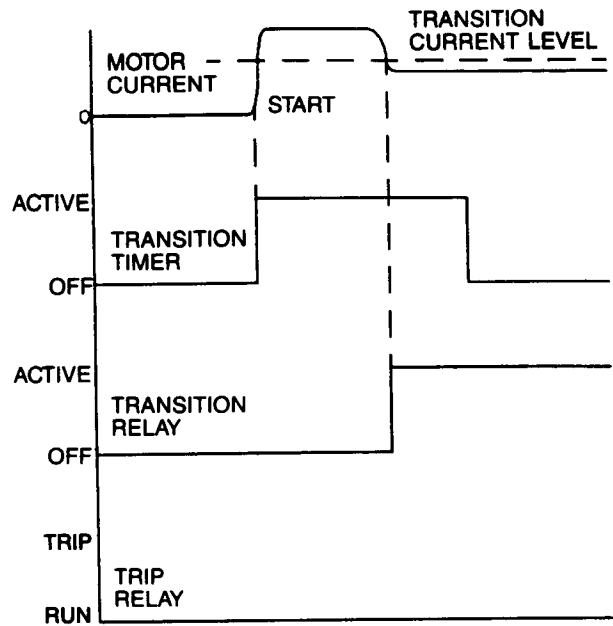
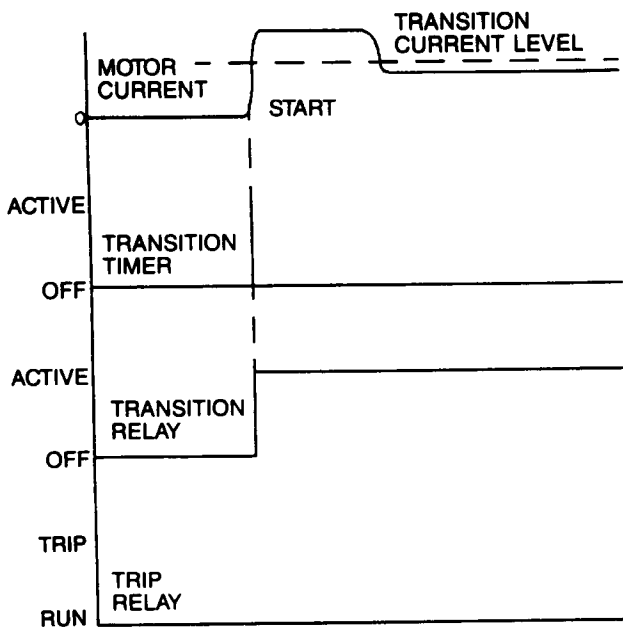

**FULL VOLTAGE START (ACROSS-THE-LINE) LOW-HIGH VOLTAGE TRANSITION**

TRANSITION CURRENT (ITEM 37) = N/A  
 TRANSITION TIME (ITEM 38) = 0 SEC  
 TRIP/TRANSITION (ITEM 39) = TRANS

TRANSITION CURRENT (ITEM 37)  $\geq$  NORMAL LOAD  
 TRANSITION TIME (ITEM 38)  $\geq$  START TIME  
 TRIP/TRANSITION (ITEM 39) = USER'S CHOICE

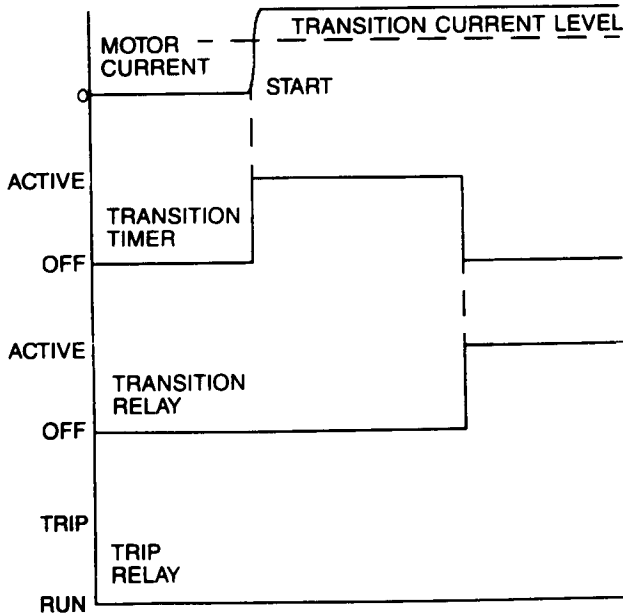

**FORCED TRANSITION ON TIME**

TRANSITION CURRENT (ITEM 37)  $\geq$  NORMAL LOAD  
 TRANSITION TIME (ITEM 38)  $\geq$  START TIME  
 TRIP/TRANSITION (ITEM 39) = TRANS

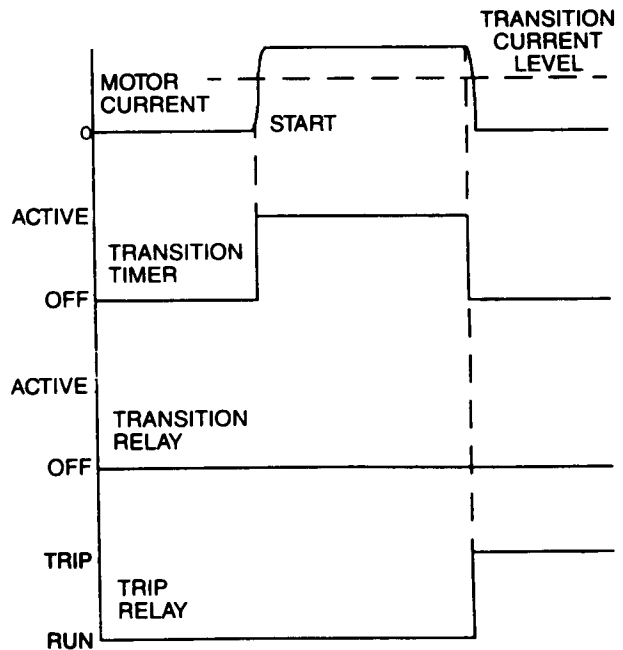

**FORCED SHUTDOWN ON TIME**

TRANSITION CURRENT (ITEM 37)  $\geq$  NORMAL LOAD  
 TRANSITION TIME (ITEM 38)  $\geq$  START TIME  
 TRIP/TRANSITION (ITEM 39) = TRIP

Figure 8.1 — Transition /Trip on Time Out Timing

If to transition on time, the transition relay can be used as a generic timer controlled by the transition time. Care must be taken to insure the current will never fall below 50% (minimum transition current level setpoint) before the transition time elapses.

**8.15.3 Setpoint Item 39, Trip/Transition on Time Out Function** — The IQ-1000 II allows the user two alternatives when the transition time (item 38) expires before a transition on current is made. One alternative is to force the transition and energize the transition relay as shown in Figure 8.1. The other is to create a transition trip to shut down the motor as in Figure 8.1. A transition trip will generate a message of "TRANS" on the display.

With this function, pressing either the Raise or Lower pushbutton causes the display to toggle between the messages:

TRN TOUT    TRP TOUT

This menu item is numbered 39 in Table 8.B.

**8.16 Setpoint Item 40, Incomplete Sequence Time** — The incomplete sequence time (in seconds) operates in conjunction with the incomplete sequence terminals on the rear of the IQ-1000 II (terminals 9 and 10, see Figure 8.3). As the IQ-1000 II enters the RUN mode, the incomplete sequence timer starts its count. If the timer runs out (i.e., the time programmed at menu item 40 expires) before 120 VAC has been received across terminals 9 and 10, then the IQ-1000 II will generate a trip condition and will display the message "INC SEQ." If 120 VAC is received at terminals 9 and 10 before the timer runs out, the IQ-1000 II will acknowledge the signal, and the 120 VAC is no longer monitored. The timing cycle of events is shown in Figure 8.2.

One common use of this report back is with auxiliary contacts on a contactor to make sure that it closed. For example, it could be used in a conveyer belt line, where two motors are controlling segments in the conveyer line. If using an IQ-1000 II on the first motor, a signal could be input into the IQ-1000 II to ensure that the second motor on the conveyer line has started (i.e., the

contactor has closed).

In another example, the report-back timer could be used in an application having an oil pump and a compressor. By wiring the oil pump control circuit into the incomplete sequence contacts, the IQ-1000 II can verify that the pump is running when the compressor is running. If the report-back contacts do not see 120 VAC from the pump before the timer runs out, the compressor will be shut off.

The incomplete sequence report-back function is displayed in the program menu as:

INSQ xx

Here the letters xx represent the incomplete sequence timer duration. This menu item is numbered 40 in Table 8.B.

The range of available setpoint values is:

Time: 1-60 seconds  
(in 1 second increments)

**NOTE**  
This function is disabled from the factory with jumpers from terminals 4 to 10 and 6 to 9. If using this function, remove the two jumpers.

**8.17 Setpoint Item 41, Anti-backspin Delay** — The anti-backspin delay function prevents a motor restart for the duration of the user-specified time. Timing begins concurrently with a trip or stop condition. This function guards against any attempt to start the motor while it is rotating in a reverse direction, as may be caused with certain types of loads. A typical example is the backspin of a pump and motor caused by the descent of a column of water after pumping is terminated.

The anti-backspin delay feature can also be used for special motors that must sit idle for a time before being restarted. For example, many air-conditioning motor manufacturers recommend that their motors not be restarted for one minute after

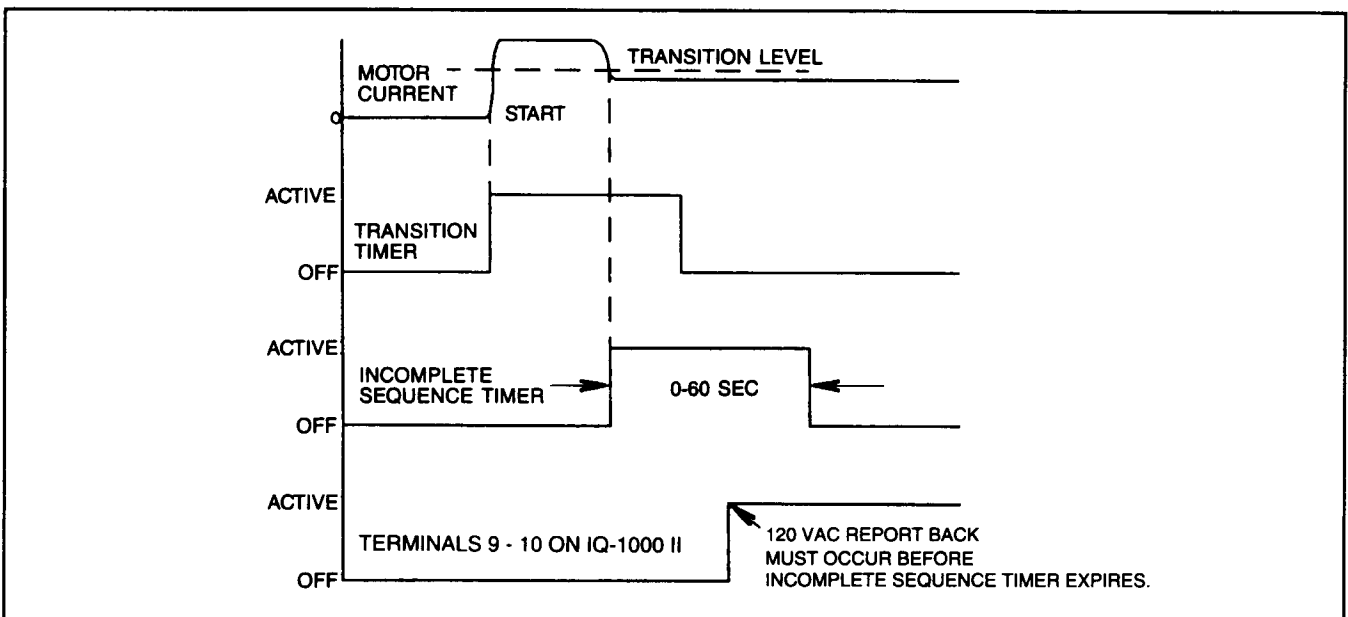

Figure 8.2 — Incomplete Sequence Timing

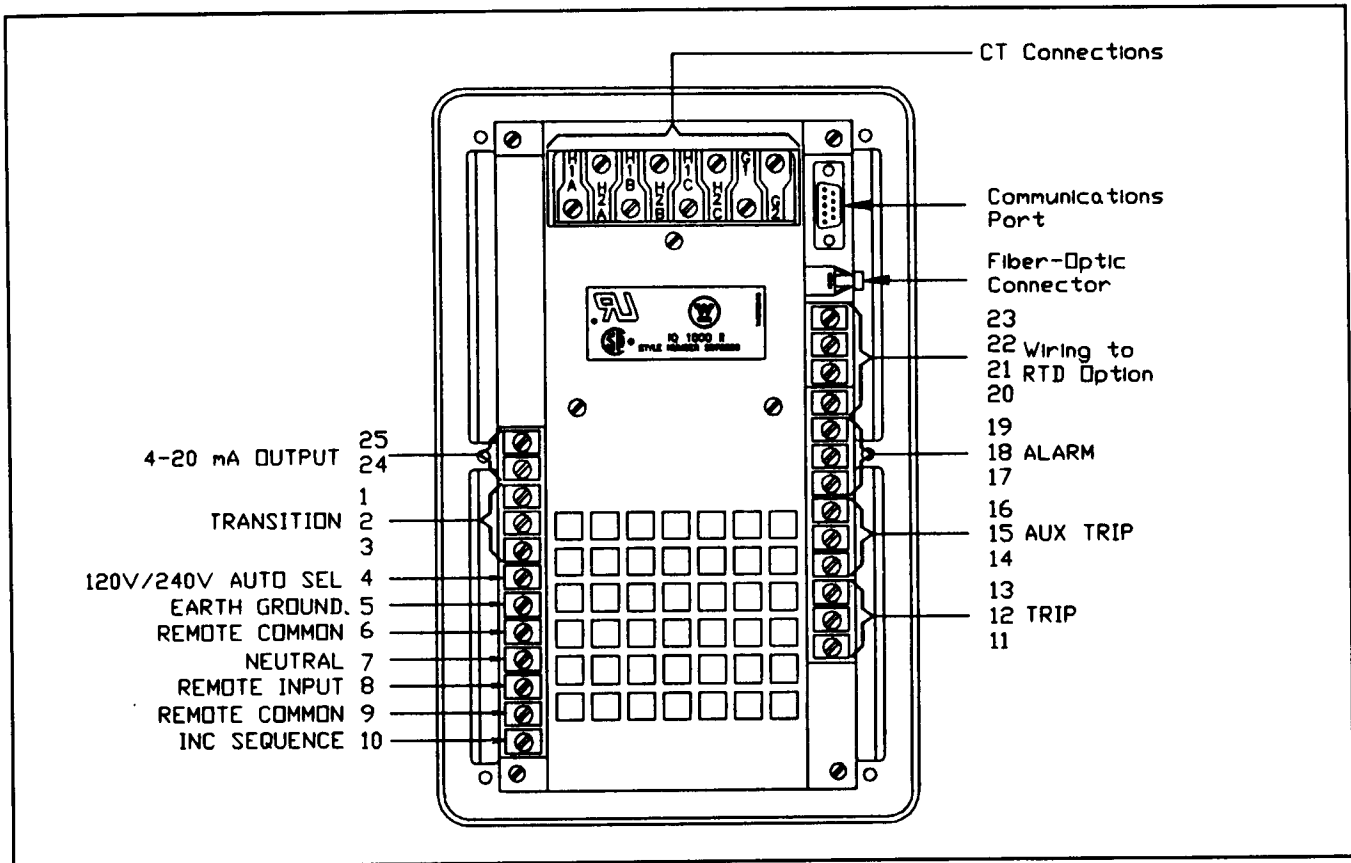

Figure 8.3 — IQ-1000 II Terminals

they have been turned off, to ensure that the motor has stopped. In a case like this, the IQ-1000 II could be programmed for 60 seconds to prevent the motor from being restarted until the timer runs out.

The anti-backspin delay function is displayed in the program menu as:

ABKS xxx

Here the letters xxx represent the user-specified duration. This menu item is numbered 41 in Table 8.B.

The range of available setpoint values is:

Time: 0-600 seconds  
(in 1 second increments)

\*\* Disable setting for ABKS — 0 seconds \*\*

**8.18 Setpoint Item 42, Full-load Amperes** — The full-load amperes function specifies the maximum continuous RMS current that can be permitted in a motor stator. This value is determined by the motor manufacturer's full-load ampere rating at unity service factor.

**Proper performance of the IQ-1000 II is directly dependent upon this user-entered variable.** The full load ampere function is used in conjunction with the current transformer ratio (item 39) to scale the incoming currents into a per unit basis for calculation and then again to display metered values of current.

**CAUTION**

Many of the IQ-1000 II's protection functions, including the motor temperature protection algorithm, use the full-load ampere setpoint value to calculate trip points. If the user enters an incorrectly determined setpoint, motor damage can result.

**NOTE**

When in the run mode, the run-monitor percent of full-load current (monitor menu items % I<sub>A</sub>, % I<sub>B</sub>, % I<sub>C</sub>) is established by the full-load amperes setpoint function.

The full-load amperes function is displayed in the program menu as:

FLA xxxx

Here the letters xxxx represent the manufacturer's recommended full-load amperes specification for the motor. This menu item is numbered 42 in Table 8.B.

The range of available setpoint values is:

Current: 10-3000 amperes  
(in 1 ampere increments)

This function **must** be programmed into the IQ-1000 II.

**8.19 Setpoint Item 43, Frequency** — The IQ-1000 II may operate from either a 60 Hz or 50 Hz AC line. A selection must be made by means of the 50/60 Hz line frequency function. There are no hardware settings necessary.

The 50/60 Hz line frequency function is displayed in the program menu as:

FREQ 50    FREQ 60

With either of these two displays showing, pressing either the Raise or Lower pushbutton causes the other to appear.

This menu item is numbered 43 in Table 8.B.

**NOTE**

Selecting the wrong frequency can create an opto error trip if voltage is applied to the Remote Input terminal (8) or the Incomplete Sequence terminal (10).

**8.20 Setpoint Item 44, Trip Relay Modes** — One of two different Trip Relay reaction modes may be selected by the user in response to a number of operating conditions. These are:

Mode 1: Trip Relay is de-energized normally and energizes during a trip condition

Mode 2: Trip Relay is energized normally and de-energizes during a trip condition or loss of AC control power

One of these two selections must be made for each application. The selection depends on the desired effect of an AC power loss on an application, as described in Paragraphs 8.20.1 and 8.20.2.

**8.20.1 Mode 1** — When Trip Mode 1 function is selected, the Trip and Auxiliary Trip Relays will energize only on a trip and auxiliary trip condition, respectively. The Trip/Auxiliary Trip Relays are in the de-energized state when any of the following conditions occur:

- When AC line power to the IQ-1000 II is lost or interrupted
- When certain IQ-1000 II hardware — such as a blown fuse or failed power supply — experiences an internal failure
- During normal motor run operations
- During the normal AC power-up sequence

The Trip/Auxiliary Trip Relays are only energized when a trip/auxiliary trip condition(s) is/are detected. The user should tie to the **normally-closed** contacts for normal operation.

The advantage of this setting is that the application's motor can continue to operate even though the IQ-1000 II has shut down. This situation could occur in those cases where the continuation of the process or running of the machine is more important than the immediate protection of the motor.

**NOTE**

It is the application engineer's responsibility to choose the NO/NC pair of Trip Relay and Auxiliary Trip Relay contacts to properly enable the motor contactor.

The Trip Mode 1 function is displayed in the program menu as:

**MODE 1**

In this case, pressing either the Raise or Lower pushbutton causes the MODE 2 display to appear.

This menu item is numbered 44 in Table 8.B.

**8.20.2 Mode 2** — When Trip Mode 2 function is selected, the Trip and Auxiliary Trip Relays energize after power up initialization (approximately 6 seconds) and de-energize on a trip/auxiliary trip condition. The Trip/Auxiliary Trip Relays are in the energized state when any of the following conditions occur:

- After the normal AC power-up sequence
- During normal motor run operations

The Trip/Auxiliary Trip Relay(s) is/are de-energized when a trip/auxiliary trip condition is/are detected. The user should tie to the **normally-open** contacts for normal operation.

The advantage of this setting is that the application's motor is turned off when the IQ-1000 II stops operating. Here the continuation of the process or running of the machine is seen to be less valuable than the protection of the motor.

**NOTE**

It is the application engineer's responsibility to choose the NO/NC pair of Trip Relay and Auxiliary Trip Relay contacts to properly enable the motor contactor.

The Trip Mode 2 function is displayed in the program menu as:

**MODE 2**

In this case, pressing either the Raise or Lower pushbutton causes the MODE 1 display to appear.

This menu item is numbered 44 in Table 8.B.

**8.21 Setpoint Item 45, Reversing/Non-reversing Starter** — The reversing/non-reversing starter function specifies the type of starter actually used in the application.

The reversing/non-reversing starter is displayed as one of the following in the program menu:

REV    NON REV

With either of these two displays showing, pressing either the Raise or Lower pushbutton causes the other to appear. This menu item is numbered 45 in Table 8.B.

This function **must** be properly selected and entered according to application requirements. If non-reversing is selected and the motor is reversed, a phase reversal trip will occur and the message "PH REVR" will be displayed.

**8.22 Setpoint Item 46, Trip/Reset/Differential Trip/Motor Stop on Remote Input** — The trip/reset/differential trip on remote input function specifies which one of three available ways the REMOTE INPUT (terminal 8 on the back of the IQ-1000 II) will function. The remote input **must** be a 120 VAC signal.

In the **trip** (REM TRIP) mode, the IQ-1000 II will generate a trip and display the message "REMOTE" on the display. If the Reset button is pushed or a reset command sent over INCOM, the trip will reset only if voltage has been removed from terminal 8.

When this function is placed in the **reset** (REM RST) mode, the IQ-1000 II will perform a reset according to the present mode of the unit. For example, if the unit is in the Program mode, it will return to the top of the program list. If the unit is in the Protection mode, it will display the status of the motor. This reset function will react in the same manner as pushing the Reset pushbutton.

In the **differential trip** (DIF TRIP) mode, the IQ-1000 II will generate a trip and display the message "DIF TRIP" on the display. If the Reset button is pushed or a reset command sent over INCOM, the trip will reset only if voltage has been removed from terminal 8.

In this case, the normally open relay of a separate, external differential relay should be wired to the REMOTE INPUT (terminal 8) on the rear of the IQ-1000 II. When the external relay detects a trip, the normally open relay will close, applying 120 VAC across terminals 8 and 9 on the back of the IQ-1000 II. At this time, the IQ-1000 II's trip relay will activate and the message "DIF TRIP" will be displayed.

When the **motor stop** (MTR STOP) function is selected, the IQ-1000 II will exit the "RUN" mode only when 120 VAC has been removed from terminal 8. This feature is primarily designed for applications using synchronous motors, when the motor is used for power factor correction. In these applications, motor current can drop to zero, causing the IQ-1000 II to enter the "READY -- 3" mode. When the IQ-1000 II enters the "READY -- 3" mode, the anti-backspin timer is initiated and all protection features (except for RTD temperature protection) are disabled.

In order to operate in applications similar to the one described above, a normally open auxiliary contact on the motor starter or contactor should be connected to terminals 8 and 9 on the IQ-1000 II. When the contactor opens, 120 VAC will be removed from these terminals. The IQ-1000 II will only exit the "RUN" mode after it has received a signal from the Remote Input terminal.

In the **reset disable** (RESET DBL) mode, the Reset pushbutton on the faceplate of the IQ-1000 II is disabled following a trip condition. When this mode is selected, the only way to reset the unit following a trip is by applying 120 VAC to terminal 8 of the IQ-1000 II. This feature can be used to prevent unauthorized personnel from resetting the unit and restarting the motor after a trip. This could be accomplished, for example, by connecting a pushbutton with padlock attachment between terminals 8 and 9. Only personnel with a key to the padlock would be able to reset the unit. The faceplate reset will operate as long as a trip or alarm is not present — as soon as trip or alarm is present faceplate reset will be disabled.

When this function is displayed, it will toggle between the following five messages:

RST DBL REM TRIP REM RST DIF TRIP MTR STOP

This menu item is numbered 46 in Table 8.B.

**8.23 Setpoint Item 47, 4-20 mA Output Signal** — The IQ-1000 II provides a 4-20 mA analog output signal at terminals 23 and 24 on the rear of the IQ-1000 II (see Figure 8.3). This signal can be input into an ammeter or programmable controller for external manipulation of parameters monitored by the IQ-1000 II.

If an input device to receive the analog signal is not present,

there is no need to enter these values.

The 4-20 mA analog output is proportional to a user-selected parameter that is measured by the IQ-1000 II. The following parameters can be selected:

- (1) 100% of Full Load Amps — the 4-20 mA signal is proportional to the average of the three-phase current values, with 100% of FLA equal to 20 mA. The 100% FLA analog output function is displayed in the program menu as:

MAX 100

- (2) 125% of Full Load Amps — the 4-20 mA signal is proportional to the average of the three-phase current values, with 125% of FLA equal to 20 mA. The 125% FLA analog output function is displayed in the program menu as:

MAX 125

- (3) Percent I<sup>2</sup>T Trip Level — the 4-20 mA signal is proportional to the percent I<sup>2</sup>T trip level, with 100% of the I<sup>2</sup>T trip level equal to 20 mA. The percent I<sup>2</sup>T trip analog output function is displayed in the program menu as:

MAX %I<sup>2</sup>T

- (4) Winding Temperature — the 4-20 mA signal is proportional to the maximum winding RTD temperature if RTDs are used. The winding RTD trip level (setpoint item 3) is equal to 20 mA. The winding temperature analog output function is displayed in the program menu as:

MAX WRTD

When this function is used, it will toggle between the following four messages:

MAX 100

MAX 125

MAX %I<sup>2</sup>T

MAX WRTD

In the Program mode, pressing either the Raise or Lower pushbutton causes the display to step through the items displayed above.

This menu item is numbered 47 in Table 8.B.

#### **8.24 Setpoint Item 48, Trip State for Auxiliary Trip Relay** —

The IQ-1000 II has one programmable form-C relay, the Auxiliary Trip relay. This relay can be programmed to activate only on certain trip conditions. This relay is labeled as terminals 14, 15 and 16 on the rear of the IQ-1000 II (see Figure 8.3). The following trip states can be programmed for the Auxiliary Trip relay:

**AUX ALL** — Auxiliary trip relay will change state for any trip condition detected by the IQ-1000 II.

**AUX IOC** — Auxiliary trip relay will change state only when the IQ-1000 II detects an Instantaneous Overcurrent trip condition (see Paragraph 8.5).

**AUX I<sup>2</sup>T** — Auxiliary trip relay will change state only when the IQ-1000 II detects an I<sup>2</sup>T trip condition (see Paragraph 8.8).

**AUX GFLT** — Auxiliary trip relay will change state only when the IQ-1000 II detects a Ground Fault trip condition (see Paragraph 8.4).

**AUX JAM** — Auxiliary trip relay will change state only when

the IQ-1000 II detects a Jam trip condition (see Paragraph 8.10).

AUX UL — Auxiliary trip relay will change state only when the IQ-1000 II detects an Underload trip condition (see Paragraph 8.11).

AUX MBT — Auxiliary trip relay will change state only when the IQ-1000 II detects a Motor Bearing trip condition (see Paragraph 8.3.2).

AUX LBT — Auxiliary trip relay will change state only when the IQ-1000 II detects a Load Bearing trip condition (see Paragraph 8.3.3).

AUX WT — Auxiliary trip relay will change state only when the IQ-1000 II detects a Winding trip condition (see Paragraph 8.3.1).

AUX REV — Auxiliary trip relay will change state only when the IQ-1000 II detects a Motor Reversal trip condition (see Paragraph 8.21).

When this function is displayed in the Program mode, the following messages can be scrolled through using the Raise and Lower step buttons:

AUX ALL	AUX UL
AUX IOC	AUX MBT
AUX I <sup>2</sup> T	AUX LBT
AUX GFLT	AUX WT
AUX JAM	AUX REV

This menu item is numbered 48 in Table 8.B.

**NOTE**

The Alarm relay will change state when any alarm condition is detected by the IQ-1000 II.

The Trip relay will change state when any trip condition is detected by the IQ-1000 II.

The Auxiliary Trip relay will only change state when the programmed trip state condition(s) has/have been detected by the IQ-1000 II.

The Trip relay on the IQ-1000 II will always change state at the same time that the Auxiliary Trip relay changes state.

**8.25 Setpoint Item 49, Reset Number of Trips** — The IQ-1000 II is capable of storing the number of trips for most trip conditions. It will store the following:

- Number of Locked Rotor Current/I<sup>2</sup>T trips
- Number of Instantaneous Overcurrent trips
- Number of Underload trips
- Number of Jam trips
- Number of Ground Fault trips
- Number of RTD trips

Each of these items can be reset to zero while the IQ-1000 II is in the Program mode. If the RST TRIP message is displayed last while in the Program mode, all trip counter values will be reset to zero when the keyswitch is placed in the Protection mode.

The display will toggle between the following two messages:

TRIP CNT    TRIP RST

This menu item is numbered 49 in Table 8.B.

**8.26 Setpoint Item 50, Reset Maximum Values** — The IQ-1000 II is capable of storing the following maximum values:

- Maximum phase current (in "RUN" cycle)
- Maximum winding RTD temperature

Both of these items can be reset to zero while the IQ-1000 II is in either the Protection or Program mode. The maximum value reset feature is displayed as one of the following in the program menu:

MX R-DBL    MX RESET    MX R-EBL

These items can be displayed individually by pressing the Raise or Lower pushbutton.

If the **max reset disable** (MX R-DBL) setpoint is selected, the IQ-1000 II will **not** reset any of the maximum values stored in the IQ-1000 II's non-volatile memory when the keyswitch is returned to the Protection mode.

If the **max reset** (MX RESET) setpoint is selected, the IQ-1000 II will reset all of the maximum values to zero when the keyswitch is returned to the Protection mode.

If the **max reset enable** (MX R-EBL) setpoint is selected, the IQ-1000 II will **not** reset any of the maximum values stored in the IQ-1000 II's non-volatile memory when the keyswitch is returned to the Protection mode. However, each maximum value can be reset to zero individually while it is being displayed on the faceplate of the IQ-1000 II. This menu selection allows values to be reset while the motor is running.

The display will toggle between the following three messages:

MX R-DBL    MX RESET    MX R-EBL

This menu item is numbered 50 in Table 8.B.

**8.27 Setpoint Item 51, Run Program/Stop Program** — This setpoint provides the user with two options when programming setpoints in the IQ-1000 II. This setpoint is displayed in the Program menu as:

RUN PGM  
STOP PGM

Pressing the Raise or Lower pushbutton toggles the display between these two options.

If RUN PGM is selected, the motor may be started and/or run while programming the IQ-1000 II.

**CAUTION**

If setpoint 51 is set to RUN PGM, the motor may be started and/or run while programming the IQ-1000 II. When entering setpoints in the RUN PGM mode, all IQ-1000 II motor protection features are disabled and the motor is unprotected until the keyswitch is returned to the Protection position.

If STOP PGM is selected, the motor must be stopped in order to program setpoints into the IQ-1000 II. Placing the keyswitch to the Program position will not initiate the Program mode if the motor is running.

This menu item is numbered 51 in Table 8.B.

**8.28 Setpoint Item 52, Current Transformer Ratio** — The current transformer ratio function specifies the turns ratio of the application's current transformers.

**CAUTION**

Be careful when determining CT turns ratio. An improper value can cause the IQ-1000 II to receive incorrect motor current data. Motor damage could result.

Only the first factor of the ratio is entered for this setpoint. Thus, the entry of 250 represents 250:5. This value is used internally by the IQ-1000 II.

Available CT turns ratio setpoint values are:

10:5	100:5	400:5	1500:5
20:5	125:5	500:5	2000:5
25:5	150:5	600:5	2500:5
40:5	200:5	800:5	3000:5
50:5	250:5	1000:5	4000:5
75:5	300:5	1200:5	

The CT turns ratio function is displayed in the program menu as:

X/5 xxx

Here the letters xxx represent the digit/digits that appear in front of the ratio in the list above.

This item is numbered 52 in Table 8.B.

For setpoint entry purposes, refer to the application's wiring plan drawings for the correct CT ratio. Use the following criteria to select a current transformer:

- For optimum metering accuracy at low loads, select a unit which, at 100% full-load amperes, delivers from 3.5 to 4 amperes at the secondary. A CT which delivers 2.5 to 4 secondary amperes at 100% FLA is also adequate for reliable motor protection.
- Select the CT which supplies as close to 3.75 amperes as possible at 100% full-load amperes.

For example, assuming an application where the motor starter delivers 300 full-load amperes, a 400:5 primary-to-secondary ratio will deliver:

$$300 \times \frac{5}{400} = 3.75 \text{ amperes}$$

This is within the recommended range of 3.5 to 4.0 amperes. The CT ratio for this example would be 400:5.

Section 9

# TROUBLESHOOTING

**9.0 General** — This section is designed to assist maintenance personnel carry out troubleshooting procedures. It is divided into three general areas of information:

- Operator Panel monitoring procedures (Par. 9.1)
- Troubleshooting monitored equipment (Par. 9.2)
- Troubleshooting the IQ-1000 II (Par. 9.3)

**— DANGER —**

All maintenance procedures **must** be performed only by qualified personnel who are familiar with the IQ-1000 II and its associated motor and machines. Failure to observe this warning can result in serious or fatal personal injury and/or equipment damage.

All correspondence with Westinghouse, whether verbal or written, should include the software version number which appears as the first display on the program menu (item 0 in Table 8.B).

**9.1 Panel Operations** — The Operator Panel performs the following operations:

- System status message reporting (Par. 9.1.1)
- Programming setpoint values (Par. 9.1.2)
- Reviewing setpoint values (Par. 9.1.3)
- Monitoring electrical characteristics (Par. 9.1.4)

**9.1.1 System Status Messages** — The Display Window provides a reporting function during the normal operation of the IQ-1000 II. This group of messages is referred to as the system status messages. Table 9.A lists the normal operation reporting messages.

**9.1.2 Programming Setpoints** — The Operator Panel, its controls and the keyswitch are used to enter setpoint values. See Paragraph 4.3 for a detailed procedure to enter or modify setpoint values.

**9.1.3 Reviewing Setpoints** — All 52 setpoints can be reviewed while the IQ-1000 II is in the Run mode — even when the motor is actually running.

To review setpoints in the Run mode, press the Set Points pushbutton once to enable the Program menu. At this time the Step Up or Step Down pushbuttons can be used to step through the Program menu in either direction to the desired IQ-1000 II function. (The program menu is listed as Table 8.B)

**9.1.4 Monitoring Characteristics** — The run-monitor menu allows maintenance personnel/operators to observe selected operating parameters associated with the motor and motor starter. A listing and description of these electrical characteristics is contained in Table 9.B.

The metering functions are averaged over time to give stability to the readings presented. As a result, the retained metering function data may be data which occurred up to one second before the trip occurred. This is in contrast to the instantaneous response of certain trip conditions such as:

- Instantaneous overcurrent
- Ground fault

Because the instantaneous overcurrent function is actuated within one line cycle of the trip condition occurring, the frozen trip values for the phase currents will not reflect the actual current value that caused the trip.

Table 9.A

**SYSTEM STATUS MESSAGES  
(Normal Operational Reporting)**

Display	Complete Help Message	Description
READY -- X	READY TO START MOTOR – READY -- 1 SINGLE PHASE MODE READY -- 3 THREE PHASE MODE	Indicates motor can be started.
START	ATTEMPTING TO START MOTOR	Displayed during motor start cycle.
RUN	MOTOR IS RUNNING	Indicates normal condition when motor is running with no alarm or trip condition. This message is displayed after a transition has occurred.

**Table 9.B**  
**RUN-MONITOR MENU DISPLAYS**

Display	Complete Help Message	Description
I <sub>A</sub> XXX I <sub>B</sub> XXX I <sub>C</sub> XXX	PHASE A CURRENT IN AMPS PHASE B CURRENT IN AMPS PHASE C CURRENT IN AMPS	Actual AC line motor current
I <sub>G</sub> XX	GROUND FAULT CURRENT IN AMPS	Actual ground current
% I <sub>A</sub> XXX % I <sub>B</sub> XXX % I <sub>C</sub> XXX	PERCENT FULL LOAD CURRENT PHASE A PERCENT FULL LOAD CURRENT PHASE B PERCENT FULL LOAD CURRENT PHASE C	The percents of the actual monitored current (in amps)
*WT1 XXX	WINDING TEMP 1 IN DEGREES	Reading from RTD connected to terminals 1, 2, 3
*WT2 XXX	WINDING TEMP 2 IN DEGREES	Reading from RTD connected to terminals 4, 5, 6
*WT3 XXX	WINDING TEMP 3 IN DEGREES	Reading from RTD connected to terminals 7, 8, 9
*WT4 XXX	WINDING TEMP 4 IN DEGREES	Reading from RTD connected to terminals 10, 11, 12
*WT5 XXX	WINDING TEMP 5 IN DEGREES	Reading from RTD connected to terminals 13, 14, 15
*WT6 XXX	WINDING TEMP 6 IN DEGREES	Reading from RTD connected to terminals 17, 18, 19
*MBT1 XXX	MOTOR BEARING TEMP 1 IN DEGREES	Reading from RTD connected to terminals 20, 21, 22
*MBT2 XXX	MOTOR BEARING TEMP 2 IN DEGREES	Reading from RTD connected to terminals 23, 24, 25
*LBT1 XXX	LOAD BEARING TEMP 1 IN DEGREES	Reading from RTD connected to terminals 26, 27, 28
*LBT2 XXX	LOAD BEARING TEMP 2 IN DEGREES	Reading from RTD connected to terminals 29, 30, 31
*AUXT XXX	AUXILIARY TEMP IN DEGREES	
OCNT XX	OPERATION COUNT	The number of motor starts logged since unit went into service, or since the counter has been reset
RT X	RUN TIME IN HOURS	Total motor run time, as accumulated by the IQ-1000 II, to date from the first time AC power was applied, or since the counter has been reset
RMST XX	REMAINING STARTS	Number of starts remaining before motor will not be allowed to start. This is the remainder of OCNT minus actual starts.
OST XXX	TIME LEFT ON OLDEST START IN MINUTES	This is the remaining time allowed for count (in minutes) function (program menu item 34). If the motor starts/time is exceeded, this is the time which must elapse before a restart is possible.
IMX XXXX	HIGHEST PHASE CURRENT SINCE LAST RESET	Highest phase current monitored by IQ-1000 II since last reset (see setpoint item 50, Table 8.B)
WTMX XXX	HIGHEST WINDING TEMP SINCE LAST RESET	Highest winding temperature monitored by IQ-1000 II since last reset (see setpoint item 50, Table 8.B)

**Table 9.B (cont'd)**  
**RUN-MONITOR MENU DISPLAYS**

Display	Complete Help Message	Description
I <sup>2</sup> T    XX	NUMBER OF I <sup>2</sup> T TRIPS SINCE LAST RESET	Number of respective trips since last reset (see setpoint item 49, Table 8.B).
IOC    XX	NUMBER OF IOC TRIPS SINCE LAST RESET	
UL     XX	NUMBER OF UL TRIPS SINCE LAST RESET	
JAM    XX	NUMBER OF JAM TRIPS SINCE LAST RESET	
GF     XX	NUMBER OF GF TRIPS SINCE LAST RESET	
RTD    XX	NUMBER OF WINDING TEMP TRIPS SINCE LAST RESET	
ICM    XXX	ADDRESS ON THE INCOM NETWORK	Address of device if on IMPACC communications network
% I <sup>2</sup> T   XXX	PERCENT OF I <sup>2</sup> T TRIP LEVEL	Percent of I <sup>2</sup> T trip level as calculated by the IQ-1000 II. At 100%, the IQ-1000 II will initiate an I <sup>2</sup> T trip.

\*Values in the shaded area are not displayed if the Universal RTD Module is not connected or is improperly connected.

**9.2 Troubleshooting IQ-1000 II Monitored Equipment** — If the monitored equipment malfunctions, certain troubleshooting information can be used to assist in localizing the problem. When a malfunction occurs, the Operator Panel displays specific messages relating to alarm or trip conditions. The unit's monitoring abilities provide valuable information, which are divided into two categories:

- Alarm conditons (Par. 9.2.1)
- Trip conditons (Par. 9.2.2)

**9.2.1 Alarm Conditions** — An alarm condition occurs when one of the electrical characteristics exceeds its programmed setpoint value. Note, however, that some alarm characteristics must exceed the setpoint value for a programmed time value **before** the alarm condition occurs.

When this condition happens, the red Alarm LED lights, and a message appears in the Display Window to assist with the isolation process.

**DANGER**

Troubleshooting procedures at times involve working in equipment areas where potentially lethal voltages are present. Personnel must exercise extreme caution to avoid injury, including possible fatal injury.

External devices connected to the IQ-1000 II's Alarm relay can be used to give additional warning.

Alarm conditions all have the following in common:

- The IQ-1000 II's Alarm relay is energized when the condition occurs.
- The form C relay contacts (available at terminals 17, 18, and 19) are brought out from the Alarm relay.
- The condition is automatically cleared if the characteristic causing the condition falls to or below the setpoint. At this time the Alarm LED and Alarm relay reset.

**NOTE**

The Alarm relay will change state when any alarm condition is detected by the IQ-1000 II.  
 The Trip relay will change state when any trip condition is detected by the IQ-1000 II.  
 The Auxiliary Trip relay will only change state when the programmed trip state condition(s) has/have been detected by the IQ-1000 II (see Paragraph 8.24).  
 The Trip relay on the IQ-1000 II will always change state at the same time that the Auxiliary Trip relay changes state.

All possible alarm conditions are listed in Table 9.C. Related probable causes and solutions are also shown.

**9.2.2 Trip Conditions** — A trip condition is a situation that changes the state of the Trip relay and, in some cases, the Auxiliary Trip relay, thereby causing the main contactor to open and the motor to stop running. These conditions fall into two groups:

- When the selected characteristics are greater than the programmed setpoint values (including, in some cases, a time setpoint), a trip condition occurs. The red Trip LED lights, and a message appears in the display window to assist the operator.
- The IQ-1000 II may also detect a malfunction. These may be external to the control — such as a broken report-back signal wire from the machine or process. There are also conditions which may be internal to the control — such as an opto-coupler failure (see Paragraph 9.3).

**NOTE**

The STEX alarm is conditional. While the motor is running, it is an alarm. If the motor is stopped, it becomes a trip.

Trip conditions have these characteristics in common:

- A picture of the metering functions just prior to the occur-

rence of a trip is stored in memory and can be recalled by pressing the Step Up or Step Down pushbuttons to step through the run-monitor menu. The order of the electrical characteristics displayed is identical to the listing in Table 9.B.

- The display window automatically alternates between the last run-monitor menu or program menu item displayed and the trip condition's cause. If two trip conditions occur at the same time, the display alternates between the menu item and the cause of each trip.
- The internal Trip (and, in some cases, Auxiliary Trip) relay is actuated when the condition occurs.
- The form C relay contacts (terminals 11, 12, and 13) are brought out from the Trip relay. (Auxiliary Trip relay contacts are terminals 14, 15 and 16; see Figure 9.1).
- The trip condition must be manually reset by using the Reset pushbutton. The remote reset input (terminal 8), REMOTE INPUT, or INCOM command can also be used to reset the trip condition.

**NOTE**

The picture of the metering function data is retained by the IQ-1000 II, as described in Paragraph 9.1.4. Pressing the Reset pushbutton clears the electrical characteristics stored when the trip condition occurred. If, after depressing the Reset pushbutton, the LRC/I<sup>2</sup>T (locked rotor or thermal overload) or STEX (starts per allowed time exceeded) message appears, wait for the trip to reset itself.

Trip conditions which are not the result of a possible internal malfunction are listed in Table 9.D. Related probable causes and solutions are also shown.

**NOTE**

If the Program menu is being examined while the IQ-1000 II is in the Run mode and a trip condition occurs, the run-monitor menu will not be automatically displayed. Press the Set Points pushbutton to display the protection-monitor menu (Table 9.B).

**9.3 Troubleshooting the IQ-1000 II Unit** — Troubleshooting the IQ-1000 II is straightforward. If the Operator Panel is inoperative (either the LEDs and display window are off, or they are not responding properly), use the procedures listed in Table 9.E. When doing so, keep in mind that the most probable problems or the simplest to verify are listed first. For this reason, always follow the order of the table's suggestions.

**DANGER**

If the IQ-1000 II is replaced, it is necessary to reprogram all setpoint values that apply to the specific IQ-1000 II application. **Do not** attempt to restart the motor until all values are entered and validated. (Use the application's Set Point Record Sheet and Paragraph 4.3.) Damage to equipment and/or personnel injury may occur if this procedure is not followed.

The IQ-1000 II performs continuous internal diagnostic checks. If a malfunction is detected during a diagnostic check, one of

Table 9.C

**ALARM CONDITIONS**

Display	Complete Help Message	Probable Cause	Solution
I <sup>2</sup> TA	I SQUARED T ALARM LEVEL	The monitored rotor temperature exceeded the alarm level setpoint (60 to 100% of max. temp.).	Monitor electrical characteristics to further isolate the malfunction to an area such as the incoming AC line, or motor/load.
STEX	ALLOWED STARTS EXCEEDED, WAIT IN MINUTES	All of the allowed starts have been used	Wait the number of minutes shown on display or reset by entering program mode.
WD AA	WINDING TEMP ALARM	In each case the actual electrical value monitored is equal to or greater than the alarm setpoint value for the function displayed.	With each of the 6 different displays (at left), perform a monitoring function to further isolate the malfunction. Note: If the actual temperature of one or more of the RTDs does not correspond to the reading in °C, suspect the RTDs, RTD wiring, or the RTD Module.
MB AA	MOTOR BEARING ALARM		
LB AA	LOAD BEARING ALARM		
PU AA	PHASE UNBALANCE ALARM		
JAMA AA	JAM ALARM		
ULA AA	UNDERLOAD ALARM		

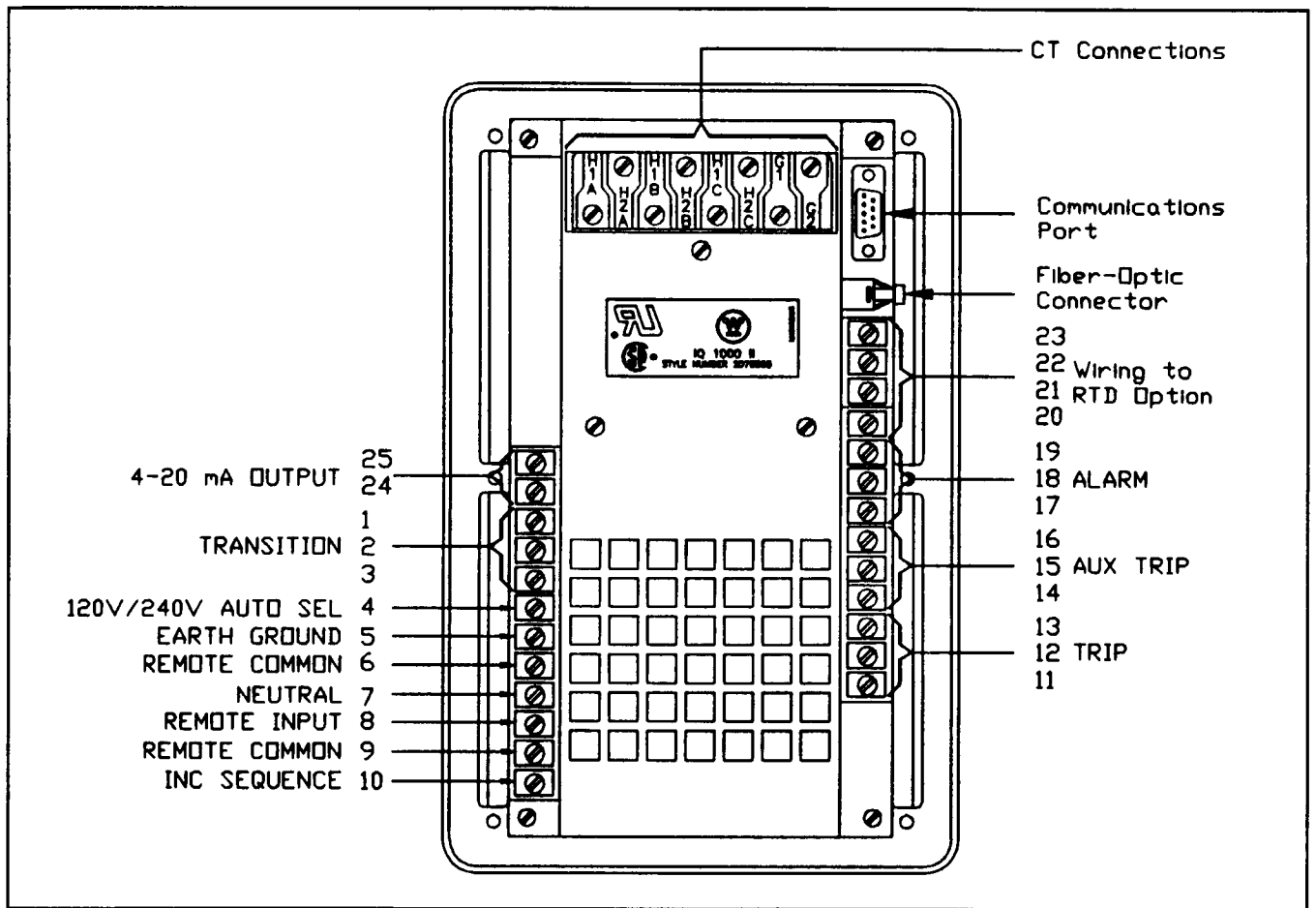

Figure 9.1 — IQ-1000 II Rear Terminals

the messages listed in Table 9.F is displayed. In each case, if any of the failure messages listed in the table occurs, a trip condition is initiated. The following actions should be taken:

- Press the Reset pushbutton to clear the display, if possible.

- Try to restart the motor.

If the same display occurs again, the IQ-1000 II is malfunctioning, and the unit should be replaced.

**Table 9.D**  
**TRIP CONDITIONS**

Display	Complete Help Message	Probable Cause	Solution
IOC	INSTANTANEOUS OVERCURRENT TRIP	In each case the actual electrical value monitored is greater than the trip setpoint value for the function displayed.	Monitor the associated electrical characteristics (as listed in Table 9.B) to further isolate the problem.
GND FLT	GROUND FAULT TRIP		
JAM	LOAD JAM TRIP		
UNDER L	UNDERLOAD RUN TRIP		
MB TEMP	MOTOR BEARING OVER TEMPERATURE TRIP		
LB TEMP	LOAD BEARING OVER TEMPERATURE TRIP		
WD TEMP	STATOR WINDING OVER TEMPERATURE TRIP		
LRC/I <sup>2</sup> T	LOCKED ROTOR/THERMAL OVERLOAD TRIP	The rotor winding temperature storage, as directed by the IQ-1000 II's motor temperature algorithm, has exceeded the maximum allowable value of the I <sup>2</sup> T protection curve (motor overload curve).	Monitor the electrical characteristics associated with the motor current to further isolate a problem to areas such as the AC line or motor overload.
INC SEQ	INCOMPLETE SEQUENCE TRIP	The INC SEQUENCE input (terminal 10) was not energized within the incomplete sequence time after a transition has taken place.	Monitor terminal 10 after a transition to the run mode. Check circuits connected to terminal 10, such as incomplete sequence, field loss, pull-out protection, etc.
REMOTE	REMOTE TRIP	The REMOTE INPUT (terminal 8), used to initiate the remote trip, was energized.	Check wiring to terminal 8 to determine external cause of trip.
DIF TRIP	DIFFERENTIAL TRIP	The REMOTE INPUT (terminal 8), used to initiate the differential trip, was energized	Check status of external differential relay
PH UNBAL	PHASE UNBALANCE TRIP	Single phasing of motor.	Monitor the incoming AC line.
PH REVRS	PHASE REVERSAL TRIP	During initial startup a phase reversal condition exists.	Rotate two of the incoming power leads L1, L2, or L3. Check for proper motor rotation.  Alternately, change the IQ-1000 II current transformer wiring by rotating the current transformer wiring terminal H1B with H1C. Clearly mark the new wiring and update the drawings for future reference.

**Table 9.D**  
**TRIP CONDITIONS**  
(cont'd)

Display	Complete Help Message	Probable Cause	Solution
T BYPASS	TRIP BYPASS (JUMPER BYPASS OF IQ-1000 II TRIP RELAY)	A trip condition is active, yet the IQ-1000 II still monitors motor current. This indicates Trip relay's contacts have been "bypassed."	Examine wiring of Trip relay's contacts and remove bypass condition.
INCOM	INCOM REMOTE TRIP	The INCOM communication option has initiated a trip condition.	Determine and correct cause of remote trip external to the IQ-1000 II.
STEX	MAX # STARTS PER TIME REACHED, WHILE RUNNING ALARM ONLY, IF STOPPED BECOMES TRIP	Too many starts were used in the allowed period of time.	Wait for the starts to be returned or clear starts by entering Program mode.
TRANSIT'	LOW TO HIGH VOLTAGE TRANSITION ERROR TRIP	IQ-1000 II did not transition on current before the transition time was complete.	Reset trip, check reason for slow start and restart motor.

1. This trip is initiated only if program menu item 39 is selected for the trip on time out function (TRP TOUT) and the motor current remained too high during the motor's start cycle. Paragraph 8.15 describes transition timing.

**Table 9.E**  
**TROUBLESHOOTING: OPERATOR PANEL MALFUNCTIONING**

Symptom	Probable Cause	Solution
All LEDs and display windows are off or unintelligible.	Incoming AC deficient.  IQ-1000 II malfunctioning	Verify that 120 or 240 VAC ( $\pm 15\%$ ) exists between terminals 4 and 7. (Refer to the electrical drawings to further isolate a deficient AC line.)  Verify that all connections to the terminal blocks are secure.  Turn keyswitch to the Program position for 5 seconds, then return to the Protection position.  If all connections are secure and the Operator Panel is still inoperative, then replace the IQ-1000 II.
OPTO ERR message	Optocoupler failure trip	Check frequency setting
Metered readings too low	Incorrect CT's — secondary amps not within 2.5–5 amps	Match CT's, CT ratio to deliver 2.5–4 amps secondary

**Table 9.F**  
**INTERNAL DIAGNOSTIC FAILURE MESSAGES**

Display	Complete Help Message
A/D ERR	A/D CONVERTER ERROR TRIP
RAM ERR	RAM ERROR TRIP
ROM ERR	ROM ERROR TRIP
OPTO ERR	OPTO COUPLER FAILURE TRIP <sup>2</sup>
X — CTR	<p>THE RATIO OF FLA TO CT RATIO EXCEEDED 5. PLEASE REDUCE FLA SETTING OR INCREASE CT RATIO.<sup>1</sup></p> <p>Note: This help message may be different on some of the early production units.</p>
ZRAM ERR	NON VOLATILE MEMORY ELEMENT SHOULD BE REPLACED
<p>NOTES:</p> <ol style="list-style-type: none"> <li>1. The current transformer ratio (item 39) and/or full load ampere (item 32) setpoint values are incorrectly selected. Verify that the setpoints for these menu items on the application's Set Point Record Sheet are entered correctly.</li> <li>2. Refer to Table 9.E.</li> </ol>	

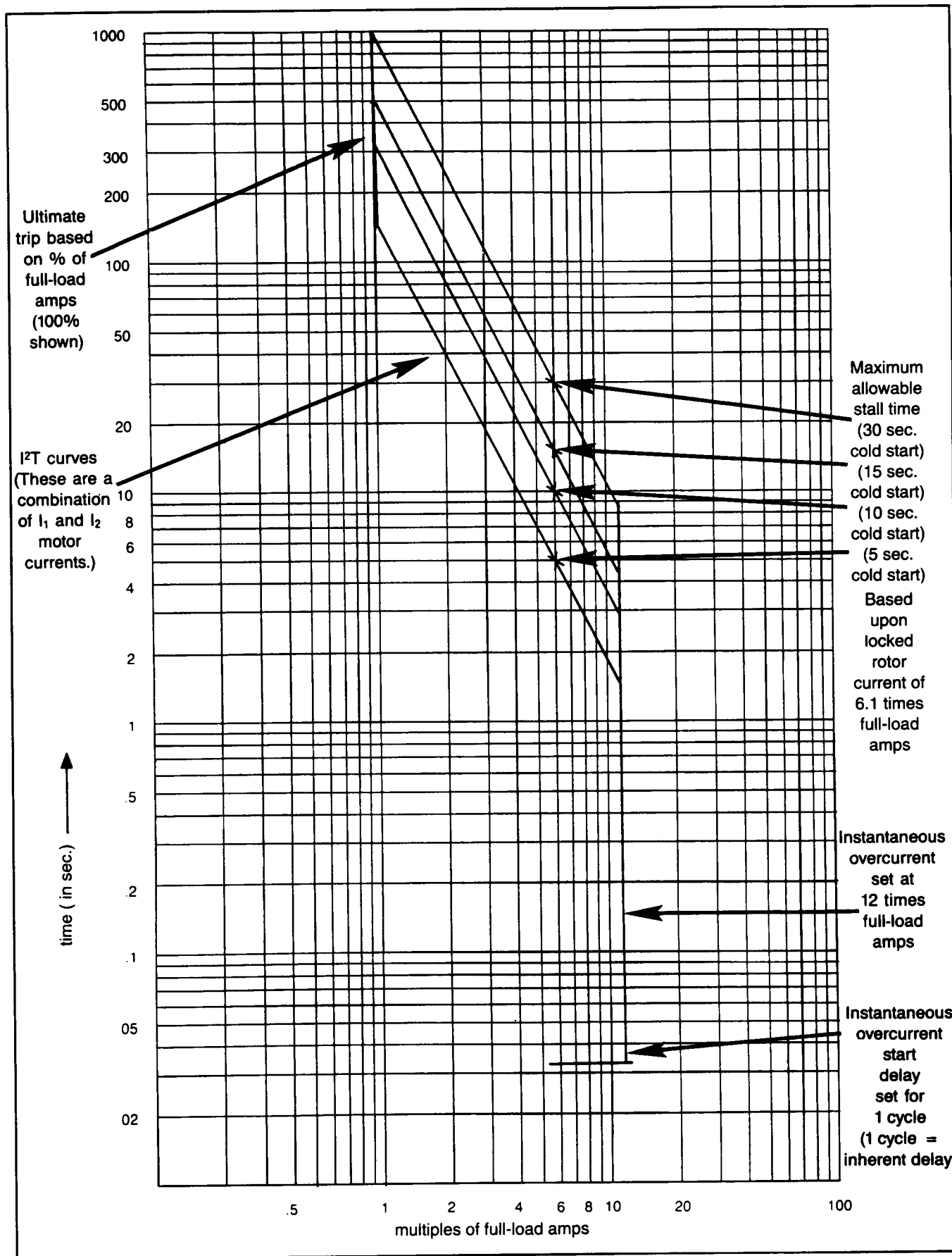

Figure 7.2 — Motor Protection Curve