



**TRANE®**

# **Installation Operation Maintenance**

---

## **Series R Air-Cooled Helical Rotary Liquid Chillers**



**Models**  
RTAC 140-500 ton units (60 Hz)  
RTAC 140-400 ton units (50 Hz)

---

January 2006

RTAC-SVX01F-EN

**NOTICE:** Warnings and Cautions appear at appropriate sections throughout this literature. Read these carefully.

**⚠ WARNING:** Indicates a potentially hazardous situation which, if not avoided, could result in death or serious injury.

**⚠ CAUTION:** Indicates a potentially hazardous situation which, if not avoided, may result in minor or moderate injury. It may also be used to alert against unsafe practices.

**CAUTION:** Indicates a situation that may result in equipment or property-damage only accidents.

## **Important Environmental Concerns!**

**Scientific research has shown that certain man-made chemicals can affect the earth's naturally occurring stratospheric ozone layer when released to the atmosphere. In particular, several of the identified chemicals that may affect the ozone layer are refrigerants that contain Chlorine, Fluorine and Carbon (CFCs) and those containing Hydrogen, Chlorine, Fluorine and Carbon (HCFCs). Not all refrigerants containing these compounds have the same potential impact to the environment. Trane advocates the responsible handling of all refrigerants—including industry replacements for CFCs such as HCFCs and HFCs.**

## **Responsible Refrigerant Practices!**

**Trane believes that responsible refrigerant practices are important to the environment, our customers, and the air conditioning industry. All technicians who handle refrigerants must be certified. The Federal Clean Air Act (Section 608) sets forth the requirements for handling, reclaiming, recovering and recycling of certain refrigerants and the equipment that is used in these service procedures. In addition, some states or municipalities may have additional requirements that must also be adhered to for responsible management of refrigerants. Know the applicable laws and follow them.**

## **⚠ WARNING Contains Refrigerant!**

**System contains oil and refrigerant under high pressure. Recover refrigerant to relieve pressure before opening the system. See unit nameplate for refrigerant type. Do not use non-approved refrigerants, refrigerant substitutes, or refrigerant additives.**

**Failure to follow proper procedures or the use of non-approved refrigerants, refrigerant substitutes, or refrigerant additives could result in death or serious injury or equipment damage.**



# Table of Contents

---

<b>General Information .....</b>	<b>7</b>
Literature History .....	7
Unit Identification - Nameplates .....	7
Unit Inspection .....	8
Inspection Checklist .....	8
Loose Parts Inventory .....	8
Unit Description .....	8
<b>Installation - Mechanical.....</b>	<b>28</b>
Installation Responsibilities .....	28
Nameplates .....	28
Outdoor Unit Nameplate .....	28
Compressor Nameplate .....	28
Storage .....	29
General .....	29
Location Requirements .....	29
Setting the Unit .....	29
Isolation and Sound Emission .....	36
Noise Considerations .....	37
Foundation.....	38
Clearances.....	38
Unit Isolation and Leveling .....	41
Neoprene Isolator Installation.....	41
Drainage .....	41
Evaporator Water Piping.....	41
Evaporator Piping .....	41
Entering Chilled Water Piping.....	42
Leaving Chilled Water Piping.....	42
Evaporator Drain.....	42
Evaporator Flow Switch.....	42
Evaporator Water Pressure Drop RTAC 140 - 250 Ton .....	43
Evaporator Water Pressure Drop RTAC 250 - 500 Ton .....	44
Water Pressure Gauges .....	45
Water Pressure Relief Valves .....	46
Freeze Protection .....	46
Low Evaporator Refrigerant Cutout and % Glycol Recommendations .....	46
Procedure .....	46
Important.....	47
Specials .....	47
<b>Installation - Mechanical</b>	
<b>Remote Evaporator Option .....</b>	<b>49</b>
Line Sizing .....	53
Liquid Line Sizing Steps .....	54
Example Liquid Line Sizing.....	55
Suction Line Sizing Steps .....	56
Example Suction Line Sizing.....	56
Suction Accumulator Sizing .....	57
Example of Suction Accumulator Line Sizing .....	57
Piping Installation Procedures .....	57
Refrigerant Sensors.....	58
Refrigerant Pressure Relief Valve Venting.....	58



# Table of Contents

---

Leak Test and Evacuation .....	58
Refrigerant and Additional Oil Charge .....	60
Refrigerant Charge Determination .....	60
Oil Charge Determination .....	61
<b>Installation - Electrical.....</b>	<b>62</b>
General Recommendations .....	62
Installer-Supplied Components.....	75
Power Supply Wiring .....	75
Control Power Supply .....	76
Heater Power Supply and Convenience Outlet (Packaged Units Only) .....	76
Water Pump Power Supply .....	77
Interconnecting Wiring .....	77
Chilled Water Flow (Pump) Interlock .....	77
Chilled Water Pump Control .....	77
Alarm and Status Relay Outputs (Programmable Relays).....	78
Relay Assignments Using TechView .....	79
Low Voltage Wiring .....	79
Emergency Stop .....	79
External Auto/Stop.....	80
External Circuit Lockout – Circuit #1 and Circuit #2 .....	80
Ice Building Option .....	80
External Chilled Water Setpoint (ECWS) Option.....	81
External Current Limit Setpoint (ECLS) Option .....	81
Chilled Water Reset (CWR) .....	82
Communications Interface options.....	84
Optional Tracer Communications Interface .....	84
LonTalk Communications Interface for Chillers (LCI-C) .....	84
<b>Operating Principles.....</b>	<b>86</b>
Refrigeration Cycle .....	86
Refrigerant R134a.....	88
Compressor .....	88
Condenser and Subcooler .....	88
Expansion Valve.....	89
Evaporator .....	89
Oil System .....	89
<b>Controls Interface .....</b>	<b>91</b>
CH530 Communications Overview .....	91
Controls Interface .....	91
DynaView Interface .....	91
Key Functions .....	92
Radio Buttons .....	92
Spin Value Buttons .....	92
Action Buttons .....	92
Hot Links .....	92
File Folder Tabs .....	92
Display Screens .....	93
Basic Screen Format .....	93
Front Panel Lockout Feature .....	94
Front Panel Display During Cold Ambients.....	94



# Table of Contents

---

Modes Screen .....	95
Chiller Screen .....	101
Compressor Screen .....	101
Refrigerant Screen .....	102
Setpoint Screen .....	103
Diagnostic Screen .....	104
Power-Up .....	105
Display Formats .....	105
Units .....	105
Languages .....	105
<b>TechView .....</b>	<b>106</b>
Minimum PC requirements to install and operate TechView .....	107
Unit View .....	107
Compressor Service View .....	109
Status View .....	110
Setpoint View .....	113
Diagnostics View .....	117
Software View .....	122
Binding View .....	123
Replacing or Adding Devices .....	124
Software Download .....	124
Instructions for First Time TechView Users .....	124
<b>Diagnostics .....</b>	<b>126</b>
Legend to Diagnostics Table .....	126
<b>Pre-Start Checkout .....</b>	<b>137</b>
Installation Checklist .....	137
Receiving .....	137
Unit Location and Mounting .....	137
Unit Piping .....	137
Electrical Wiring .....	138
General .....	139
Unit Voltage Power Supply .....	140
Unit Voltage Imbalance .....	141
Unit Voltage Phasing .....	141
Water System Flow Rates .....	142
Water System Pressure Drop .....	142
CH530 Set-Up .....	143
<b>Unit Start-Up Procedures .....</b>	<b>144</b>
Daily Unit Start-Up .....	144
General .....	144
Seasonal Unit Start-Up Procedure .....	145
System Restart After Extended Shutdown .....	146
<b>Unit Shutdown Procedures .....</b>	<b>147</b>
Temporary Shutdown And Restart .....	147
Extended Shutdown Procedure .....	147



# Table of Contents

---

<b>Periodic Maintenance</b> .....	<b>149</b>
Weekly Maintenance .....	149
<b>Maintenance Procedures</b> .....	<b>155</b>
Refrigerant and Oil Charge Management .....	155
R134a Field Charging Procedure .....	156
Factory (initial) Refrigerant Charging Procedure .....	156
Field Refrigerant Charging Procedure.....	156
Adding charge:.....	157
Charge Isolation in the high or low side of system.....	157
High side charge isolation procedure: .....	157
Returning unit to running condition: .....	158
Low side charge isolation procedure:.....	158
Refrigerant Filter Replacement Procedure .....	159
Lubrication System.....	159
Oil Charging Procedure.....	159
Factory (initial) Oil Charging Procedure.....	161
Evaporator tube replacement .....	163
Compressor Replacement.....	163
<b>Unit Wiring</b> .....	<b>165</b>



# General Information

## Literature History

RTAC-SVX001-EN (December 2000)  
New manual.

RTAC-SVX01B-EN (September 2001)  
New manual describes installation, operation, and maintenance of RTAC units and the remote evaporator option.

RTAC-SVX01C-EN (February 2002)  
Revised manual includes additional RTAC units to size 500 tons, new installation and maintenance material, and expanded CH530 diagnostics.

RTAC-SVX01D-EN (July 2003)  
Revised manual for new evaporator design for 2 compressor units. Design Sequence H0 and later.

RTAC-SVX01E-EN (July 2004)  
Revised manual for new evaporator design for 3 and 4 compressor units. Design Sequence J0 and later.

RTAC-SVX01F-EN (January 2006)  
Revised manual for new control panel design.

## Unit Identification - Nameplates

When the unit arrives, compare all nameplate data with ordering, submittal, and shipping information. A typical unit nameplate is shown in [Figure 1](#).

		SERIAL NUMBER	CRC	TYPE OF USE
MODEL NUMBER				
RATED VOLTAGE/HZ/PH	MIN CKT AMPACITY	MAX FUSE/ BRKR (1)	MAX O.C. PROT'N	REC DUAL ELMINT FUSE
CKT1				
VOLT UTILIZATION RANGE	CKT2			
				EVAP HEATER/ CONVEN OUTLET
VOLT-AC	HZ	PH	RLA	Y LRA
		3		
CPRSR MTR 1A				
CPRSR MTR 1B				
CPRSR MTR 2A				
CPRSR MTR 2B				
FAN MTRS	QTY	HP FA	FLA FA	
	3			
INSTALLATION, OPERATION, & MAINTENANCE MANUAL	WIRING BOOK		DESIGN PRESSURES	
			HIGH SIDE	LOW SIDE
			MIN MARKED DESIGN PSIG FOR ANY REMOTE COND	
			(1) HACR TYPE CB REQUIRED BY NEC	
<small>MANUFACTURED UNDER ONE OR MORE OF THE FOLLOWING U.S. PATENTS/ 4,888,827 4,718,180 4,781,883 5,000,000 5,086,002 5,086,894 5,086,021 5,027,880 5,125,286 5,225,885          CORRESPONDING FOREIGN PATENTS OWNED BY AMERICAN STANDARD INC. 5,211,288 5,227,048 5,341,288 5,424,728 5,465,488 5,491,887 5,528,048 5,558,184 5,585,881 5,628,784          The Trane Company, A Division of American Standard Inc. Made in the U.S.A.</small>				

Figure 1 Typical Unit Nameplate



## General information

---

### Unit Inspection

When the unit is delivered, verify that it is the correct unit and that it is properly equipped. Compare the information which appears on the unit nameplate with the ordering and submittal information.

Inspect all exterior components for visible damage. Report any apparent damage or material shortage to the carrier and make a "unit damage" notation on the carrier's delivery receipt. Specify the extent and type of damage found and notify the appropriate Trane Sales Office. Do not proceed with installation of a damaged unit without sales office approval.

### Inspection Checklist

To protect against loss due to damage incurred in transit, complete the following checklist upon receipt of the unit.

- Inspect the individual pieces of the shipment before accepting the unit. Check for obvious damage to the unit or packing material.
- Inspect the unit for concealed damage as soon as possible after delivery and before it is stored. Concealed damage must be reported within 15 days.
- If concealed damage is discovered, stop unpacking the shipment. Do not remove damaged material from the receiving location. Take photos of the damage, if possible. The owner must provide reasonable evidence that the damage did not occur after delivery.
- Notify the carrier's terminal of the damage immediately, by phone and by mail. Request an immediate, joint inspection of the damage with the carrier and the consignee.
- Notify the Trane sales representative and arrange for repair. Do not repair the unit, however, until damage is inspected by the carrier's representative.

### Loose Parts Inventory

Check all the accessories and loose parts which are shipped with the unit against the shipping list. Included in these items will be water vessel drain plugs, rigging and electrical diagrams, and service literature, which are placed inside the control panel and/or starter panel for shipment.

### Unit Description

The 140 - 500 ton Model RTAC units are helical-rotary type, air-cooled liquid chillers designed for installation outdoors. The compressor circuits are completely assembled, hermetic packages that are factory-piped, wired, leak-tested, dehydrated, and tested for proper control operation before shipment.

*NOTE: Packaged units are factory charged with refrigerant and oil.*

Figure 2 shows a typical RTAC packaged unit and its components.

Table 1 through Table 5 contain general RTAC mechanical specifications for all unit sizes.

## General Information

---



**Figure 2** Typical RTAC Unit

Chilled water inlet and outlet openings are covered for shipment. Each compressor has a separate compressor motor starter. The RTAC series features Trane's exclusive Adaptive Control™ logic, which monitors the control variables that govern the operation of the chiller unit. Adaptive Control logic can adjust capacity variables to avoid chiller shutdown when necessary, and keep producing chilled water. The units feature two independent refrigerant circuits. Compressor unloaders are solenoid actuated and oil pressure operated. Each refrigerant circuit is provided with filter, sight glass, electronic expansion valve, and charging valves. The shell-and-tube type evaporator is manufactured in accordance with ASME standards or other international codes. Each evaporator is fully insulated and is equipped with water drain and vent connections. Packaged units have heat tape protection to -20°F (-28.9°C) as standard. As an option, a convenience outlet can be supplied.



# General information

**Table 1 General Data — 140-250 Ton 60 Hz Units - Standard Efficiency**

Size Type	140 STD	155 STD	170 STD	185 STD	200 STD	225 STD	250 STD
<b>Compressor</b>							
Quantity	2	2	2	2	2	2	2
Nominal Size (tons)	70/70	85/70	85/85	100/85	100/100	120/100	120/120
<b>Evaporator</b>							
Water Storage (gallons)	29	32	33	35	39	38	42
(liters)	111	121	127	134	146	145	158
Min. Flow (gpm)	193	214	202	217	241	217	241
(l/sec)	12	14	13	14	15	14	15
Max. Flow (gpm)	709	785	741	796	883	796	883
(l/sec)	45	50	47	50	56	50	56
<b>Condenser</b>							
Quantity of Coils	4	4	4	4	4	4	4
Coil Length (inches)	156/156	180/156	180/180	216/180	216/216	252/216	252/252
(mm)	3962/3962	4572/3962	4572/4572	5486/4572	5486/5486	6401/5486	6401/6401
Coil Height (inches)	42	42	42	42	42	42	42
(mm)	1067	1067	1067	1067	1067	1067	1067
Fins/Ft	192	192	192	192	192	192	192
Number of Rows	3	3	3	3	3	3	3
<b>Condenser Fans</b>							
Quantity	4/4	5/4	5/5	6/5	6/6	7/6	7/7
Diameter (inches)	30	30	30	30	30	30	30
(mm)	762	762	762	762	762	762	762
Total Airflow (cfm)	77000	84542	92087	101296	110506	119725	128946
(m <sup>3</sup> /hr)	130811	143623	156441	172086	187732	203394	219059
Nominal Fan Speed (rpm)	1140	1140	1140	1140	1140	1140	1140
(rps)	19	19	19	19	19	19	19
Tip Speed (ft/min)	8954	8954	8954	8954	8954	8954	8954
(m/s)	45	45	45	45	45	45	45
<b>Min Starting/Operating Ambient</b>							
Std Unit (Deg F)	25	25	25	25	25	25	25
(Deg C)	-3.9	-3.9	-3.9	-3.9	-3.9	-3.9	-3.9
Low Ambient (Deg F)	0.0	0.0	0.0	0.0	0.0	0.0	0.0
(Deg C)	-17.8	-17.8	-17.8	-17.8	-17.8	-17.8	-17.8
<b>General Unit</b>							
Refrigerant	HFC-134a	HFC-134a	HFC-134a	HFC-134a	HFC-134a	HFC-134a	HFC-134a
No. of Independent Refrigerant Circuits	2	2	2	2	2	2	2
% Min. load	15	15	15	15	15	15	15
Refrigerant Charge (lb)	165/165	175/165	175/175	215/210	215/215	225/215	225/225
(kg)	75/75	79/75	79/79	98/95	98/98	102/98	102/102
Oil Charge (gallons)	1.5/1.5	1.5/1.5	1.5/1.5	2.1/1.5	2.1/2.1	2.1/2.1	2.1/2.1
(liters)	6/6	6/6	6/6	8/6	8/8	8/8	8/8
Base Length (feet)	15	15	15	18	18	21	21

1. Data containing information on two circuits shown as follows: CKT1/CKT 2.

2. Minimum start-up/operating ambient based on a 5 mph wind across the condenser.



# General Information

**Table 2 General Data — 275- 500 Ton 60 Hz Units - Standard Efficiency**

<b>Size Type</b>	<b>275 STD</b>	<b>300 STD</b>	<b>350 STD</b>	<b>400 STD</b>	<b>450 STD</b>	<b>500 STD</b>
<b>Compressor</b>						
Quantity	3	3	3	4	4	4
Nominal Size (tons)	85/85 100	100/100 100	120/120 100	100/100 100/100	120/120 100/100	120/120 120/120
<b>Evaporator</b>						
Water Storage (gallons)	60	65	70	81	84	89
(liters)	229	245	264	306	316	337
Min. Flow (gpm)	309	339	375	404	422	461
(l/sec)	20	21	24	26	27	29
Max. Flow (gpm)	1134	1243	1374	1483	1548	1690
(l/sec)	72	78	87	94	98	107
<b>Condenser</b>						
Quantity of Coils	8	8	8	8	8	8
Coil Length (inches)	180/108	216/108	252/108	216/216	252/216	252/252
(mm)	4572/2743	5486/2743	6401/4572	5486/5486	6401/5486	6401/6401
Coil Height (inches)	42	42	42	42	42	42
(mm)	1067	1067	1067	1067	1067	1067
Fins/Ft	192	192	192	192	192	192
Number of Rows	3	3	3	3	3	3
<b>Condenser Fans</b>						
Quantity	10/6	12/6	14/6	12/12	14/12	14/14
Diameter (inches)	30	30	30	30	30	30
(mm)	762	762	762	762	762	762
Total Airflow (cfm)	147340	165766	184151	221016	239456	257991
(m <sup>3</sup> /hr)	250307	281610	312843	375471	406797	438285
Nominal Fan Speed (rpm)	1140	1140	1140	1140	1140	1140
(rps)	19	19	19	19	19	19
Tip Speed (ft/min)	8954	8954	8954	8954	8954	8954
(m/s)	45	45	45	45	45	45
<b>Min Starting/Oper Ambient</b>						
Std Unit (Deg F)	25	25	25	25	25	25
(Deg C)	-3.9	-3.9	-3.9	-3.9	-3.9	-3.9
Low Ambient (Deg F)	0.0	0.0	0.0	0.0	0.0	0.0
(Deg C)	-17.8	-17.8	-17.8	-17.8	-17.8	-17.8
<b>General Unit</b>						
Refrigerant	HFC-134a	HFC-134a	HFC-134a	HFC-134a	HFC-134a	HFC-134a
No. of Independent Refrigerant Circuits	2	2	2	2	2	2
% Min. load	15	15	15	15	15	15
Refrigerant Charge (lb)	365/200	415/200	460/200	415/415	460/415	460/460
(kg)	166/91	188/91	209/91	188/188	209/188	209/209
Oil Charge (gallons)	4.6/2.1	5.0/2.1	5.0/2.1	5.0/5.0	5.0/5.0	5.0/5.0
(liters)	17.4/8	19/8	19/8	19/19	19/19	19/19
Base Length (feet)	30	36	36	39	45	45

1. Data containing information on two circuits shown as follows: CKT1/CKT 2.

2. Minimum start-up/operating ambient based on a 5 mph wind across the condenser.



# General information

**Table 3 General Data — 140-400 Ton 60 Hz Units - High Efficiency**

Size		140	155	170	185	200	225	250	275	300	350	400
Type		HIGH	HIGH	HIGH	HIGH	HIGH	HIGH	HIGH	HIGH	HIGH	HIGH	HIGH
<b>Compressor</b>												
Quantity		2	2	2	2	2	2	2	3	3	4	4
Nominal Size	(tons)	70/70	85/70	85/85	100/85	100/100	120/100	120/120	85/85 100	100/100 100	85/85 85/85	100/100 100/100
<b>Evaporator</b>												
Water Storage	(gallons) (liters)	33 127	35 134	39 146	38 145	42 158	42 158	42 158	70 264	70 264	81 306	89 337
Min. Flow	(gpm) (l/sec)	202 13	217 14	241 15	217 14	241 15	241 15	241 15	375 24	375 24	404 26	461 29
Max. Flow	(gpm) (l/sec)	741 47	796 50	883 56	796 50	883 56	883 56	883 56	1374 87	1374 87	1483 94	1690 107
<b>Condenser</b>												
Quantity of Coils		4	4	4	4	4	8	8	8	8	8	8
Coil Length	(inches) (mm)	180/180 4572/ 4572	216/180 5486/ 4572	216/216 5486/ 5486	252/216 6401/ 5486	252//252 6401/ 6401	144/144 3658/ 3658	180/108 4572/ 2743	216/144 5486/ 3658	252/144 6401/ 3658	216/216 5486/ 5486	252/252 6401/ 6401
Coil Height	(inches) (mm)	42 1067	42 1067	42 1067	42 1067	42 1067	42 1067	42 1067	42 1067	42 1067	42 1067	42 1067
Fins/Ft		192	192	192	192	192	192	192	192	192	192	192
Number of Rows		3	3	3	3	3	3	3	3	3	3	3
<b>Condenser Fans</b>												
Quantity		5/5	6/5	6/6	7/6	7/7	8/6	8/8	12/6	14/6	12/12	14/14
Diameter	(inches) (mm)	30 762	30 762	30 762	30 762	30 762	30 762	30 762	30 762	30 762	30 762	30 762
Total Airflow	(cfm) (m <sup>3</sup> /hr)	91993 156281	101190 171906	110387 187530	119598 203178	128812 218831	136958 232670	147242 250141	173733 295145	192098 326344	220778 375066	257626 437665
Nominal Fan Speed	(rpm) (rps)	1140 19	1140 19	1140 19	1140 19	1140 19	1140 19	1140 19	1140 19	1140 19	1140 19	1140 19
Tip Speed	(ft/min) (m/s)	8954 45	8954 45	8954 45	8954 45	8954 45	8954 45	8954 45	8954 45	8954 45	8954 45	8954 45
<b>Min Starting/Oper Ambient</b>												
Std Unit	(Deg F) (Deg C)	25 -3.9	25 -3.9	25 -3.9	25 -3.9	25 -3.9	25 -3.9	25 -3.9	25 -3.9	25 -3.9	25 -3.9	25 -3.9
Low Ambient	(Deg F) (Deg C)	0.0 -17.8	0.0 -17.8	0.0 -17.8	0.0 -17.8	0.0 -17.8	0.0 -17.8	0.0 -17.8	0.0 -17.8	0.0 -17.8	0.0 -17.8	0.0 -17.8
<b>General Unit</b>												
Refrigerant		HFC-134a	HFC-134a	HFC-134a	HFC-134a	HFC-134a	HFC-134a	HFC-134a	HFC-134a	HFC-134a	HFC-134a	HFC-134a
No. of Independent Refrigerant Circuits		2	2	2	2	2	2	2	2	2	2	2
% Min. load		15	15	15	15	15	15	15	15	15	15	15
Refrigerant Charge	(lb) (kg)	175/175 79/79	215/205 98/93	215/215 98/98	225/215 102/98	225/225 102/102	235/235 107/107	235/235 107/107	415/200 188/91	460/200 209/91	415/415 188/188	460/460 209/209
Oil Charge	(gallons) (liters)	1.5/1.5 6/6	1.5/1.5 6/6	1.5/1.5 6/6	2.1/1.5 8/6	2.1/2.1 8/8	2.1/2.1 8/8	2.1/2.1 8/8	4.6/2.2 17/8	5.0/2.2 19/8	4.6/4.6 17/17	5.0/5.0 19/19
Base Length	(feet)	15	18	18	21	21	30	30	36	39	39	45

1. Data containing information on two circuits shown as follows: CKT 1/CKT 2  
 2. Minimum start-up/operating ambient based on a 5 mph wind across the condenser



# General Information

**Table 4 General Data - 120-400 Ton 50 Hz Units-Standard Efficiency**

Size	140	155	170	185	200	250	275	300	350	375	400
Type	STD	STD	STD	STD	STD	STD	STD	STD	STD	STD	STD
<b>Compressor</b>											
Quantity	2	2	2	2	2	3	3	3	4	4	4
Nominal Size (tons)	70/70	85/70	85/85	100/85	100/100	70-70/100	85-85/100	100-100/100	85-85/85-85	100-100/85-85	100-100/100-100
<b>Evaporator</b>											
Water Storage (gallons)	29	32	33	35	38	54	60	64	73	77	80
(liters)	110	120	126	133	145	203	227	243	275	291	304
Min. Flow (gpm)	192	221	200	215	239	262	307	336	384	377	401
(l/sec)	12	13	13	14	15	17	19	21	22	24	25
Max. Flow (gpm)	702	778	735	789	875	962	1124	1232	1275	1383	1470
(l/sec)	44	49	46	50	55	61	72	78	80	87	93
<b>Condenser</b>											
Quantity of Coils	4	4	4	4	4	8	8	8	8	8	8
Coil Length (inches)	156/156	180/156	180/180	216/180	216/216	156/108	180/108	216/108	180/180	216/180	252/216
(mm)	3962/3962	4512/3962	4572/4512	5486/4572	5486/5486	3962/4512	4572/2743	5486/2743	4572/4572	5486/4572	6401/5486
Coil Height (inches)	42	42	42	42	42	42	42	42	42	42	42
(mm)	1067	1067	1067	1067	1067	1067	1067	1067	1067	1067	1067
Fins/Ft	192	192	192	192	192	192	192	192	192	192	192
Number of Rows	3	3	3	3	3	3	3	3	3	3	3
<b>Condenser Fans</b>											
Quantity	4/4	5/4	5/5	6/5	6/6	8/6	10/6	12/6	10/10	12/10	12/12
Diameter (inches)	30	30	30	30	30	30	30	30	30	30	30
(mm)	762	762	762	762	762	762	762	762	762	762	762
Total Airflow (cfm)	63346	69507	75671	83236	90803	108698	121056	136210	151332	166467	181611
(m <sup>3</sup> /hr)	107615	118081	128553	141405	154260	184661	205655	231399	257089	282801	308528
Nominal Fan Speed (rpm)	950	950	950	950	950	950	950	950	950	950	950
(rps)	15.8	15.8	15.8	15.8	15.8	15.8	15.8	15.8	15.8	15.8	15.8
Tip Speed (ft/min)	7461	7461	7461	7461	7461	7461	7461	7451	7461	7461	7461
(m/s)	38	38	38	38	38	38	38	38	38	38	38
<b>Min Starting/Oper Ambient</b>											
Std Unit (Deg F)	25	25	25	25	25	25	25	25	25	25	25
(Deg C)	-3.9	-3.9	-3.9	-3.9	-3.9	-3.9	-3.9	-3.9	-3.9	-3.9	-3.9
Low Ambient (Deg F)	0	0	0	0	0	0	0	0	0	0	0
(Deg C)	-17.8	-17.8	-17.8	-17.8	-17.8	-17.8	-17.8	-17.8	-17.8	-17.8	-17.8
<b>General Unit</b>											
Refrigerant	HFC-134a	HFC-134a	HFC-134a	HFC-134a	HFC-134a	HFC-134a	HFC-134a	HFC-134a	HFC-134a	HFC-134a	HFC-134a
No. of Independent Refrigerant Circuits	2	2	2	2	2	2	2	2	2	2	2
% Min. load	15	15	15	15	15	15	15	15	15	15	15
Refrigerant Charge (lb)	165/165	175/165	175/175	215/210	215/215	335/200	365/200	415/200	365/365	415/365	415/415
(kg)	75/75	79/75	79/79	98/95	98/98	152/91	166/91	188/91	166/166	188/166	188/188
Oil Charge (gallons)	1.5/1.5	1.5/1.5	1.5/1.5	2.1/1.5	2.1/2.1	4.6/2.1	4.6/2.1	5.0/2.1	4.6/4.6	5.0/4.6	5.0/5.0
(liters)	6/6	6/6	6/6	8/6	8/8	17.4/8	17.4/8	19.0/8	17.4/17.4	19.0/17.4	19.0/19.0
Base Length (feet)	15	15	15	18	18	30	30	36	39	39	39

1. Data containing information on two circuits shown as follows: CKT 1/CKT 2  
 2. Minimum start-up/operating ambient based on a 5 mph wind across the condenser



# General information

**Table 5 General Data - 120-400 Ton 50 Hz Units-High Efficiency**

Size		140	155	170	185	200	250	275	300	350	375	400
Type		HIGH	HIGH	HIGH	HIGH	HIGH	HIGH	HIGH	HIGH	HIGH	HIGH	HIGH
<b>Compressor</b>												
Quantity		2	2	2	2	2	3	3	3	4	4	4
Nominal Size (tons)		70/70	85/70	85/85	100/85	100/100	70-70/ 100	85-85/ 100	100-100/ 100	85-85/ 85-85	100-100/ 85-85	100-100/ 100-100
<b>Evaporator</b>												
Water	(gallons)	33	35	38	38	41	64	69	69	80	83	89
Storage	(liters)	126	133	145	145	157	243	262	262	304	314	335
Min. Flow	(gpm)	200	215	239	215	239	336	371	371	401	419	457
	(l/sec)	13	14	15	14	15	21	23	23	25	26	29
Max. Flow	(gpm)	735	789	875	789	875	1232	1362	1362	1470	1535	1675
	(l/sec)	46	50	55	50	55	78	86	86	93	97	106
<b>Condenser</b>												
Qty of Coils		4	4	4	4	4	8	8	8	8	8	8
Coil Length	(inches)	180/180	216/180	216/216	252/216	252/252	180/108	216/144	252/144	216/216	252/216	252/252
	(mm)	4572/ 4572	5486/ 4572	5486/ 5486	6401/ 5486	6401/ 6401	4572/ 2743	5486/3658	6401/ 3658	5486/5486	6401/5486	6401/ 6401
Coil Height	(inches)	42	42	42	42	42	42	42	42	42	42	42
	(mm)	1067	1067	1067	1067	1067	1067	1067	1067	1067	1067	1067
Fins/Ft		192	192	192	192	192	192	192	192	192	192	192
Number of Rows		3	3	3	3	3	3	3	3	3	3	3
<b>Condenser Fans</b>												
Quantity		5/5	6/5	6/6	7/6	7/7	10/6	12/6	14/6	12/12	14/12	14/14
Diameter	in. (mm)	30 (762)	30 (762)	30 (762)	30 (762)	30 (762)	30 (762)	30 (762)	30 (762)	30 (762)	30 (762)	30 (762)
Total Airflow	(cfm)	75575	83130	90687	98256	105826	120971	142969	158112	181371	194731	211648
	(m <sup>3</sup> /hr)	128390	141225	154063	166921	179781	205510	242881	268607	308120	330817	359556
Nominal Fan	(rpm)	950	950	950	950	950	950	950	950	950	950	950
Speed	(rps)	15.8	15.8	15.8	15.8	15.8	15.8	15.8	15.8	15.8	15.8	15.8
Tip Speed	(ft/min)	7461	7461	7461	7461	7461	7461	7461	7461	7461	7461	7461
	(m/s)	38	38	38	38	38	38	38	38	38	38	38
<b>Min Starting/Oper Ambient</b>												
Std Unit	Deg F (C)	25 (-3.9)	25 (-3.9)	25 (-3.9)	25 (-3.9)	25 (-3.9)	25 (-3.9)	25 (-3.9)	25 (-3.9)	25 (-3.9)	25 (-3.9)	25 (-3.9)
Low Ambient	Deg F (C)	0 (-17.8)	0 (-17.8)	0 (-17.8)	0 (-17.8)	0 (-17.8)	0 (-17.8)	0 (-17.8)	0 (-17.8)	0 (-17.8)	0 (-17.8)	0 (-17.8)
<b>General Unit</b>												
Refrigerant		HFC-134a	HFC-134a	HFC-134a	HFC-134a	HFC-134a	HFC-134a	HFC-134a	HFC-134a	HFC-134a	HFC-134a	HFC-134a
No. of Independent Refrigerant Circuits		2	2	2	2	2	2	2	2	2	2	2
% Min. load		15	15	15	15	15	15	15	15	15	15	15
Refrigerant Charge	(lb)	175/175	215/205	215/215	225/215	225/225	365/200	415/200	460/200	415/415	460/415	460/460
	(kg)	79/79	98/93	98/98	102/98	102/102	166/91	188/91	209/91	188/188	209/188	209/209
Oil Charge	(gallons)	1.5/1.5	1.5/1.5	1.5/1.5	2.1/1.5	2.1/2.1	4.6/2.1	4.6/2.1	5.0/2.1	4.6/4.6	5.0/5.0	5.0/5.0
	(liters)	6/6	6/6	6/6	8/6	8/8	17.4/8	17.4/8	19.0/8	17.4/17.4	19.0/19.0	19.0/19.0
Base Length (feet)		15	18	18	21	21	30	36	39	39	45	45

1. Data containing information on two circuits shown as follows CKT 1/CKT 2  
 2. Minimum start-up/operating ambient based on a 5 mph wind across the condenser

# General Information

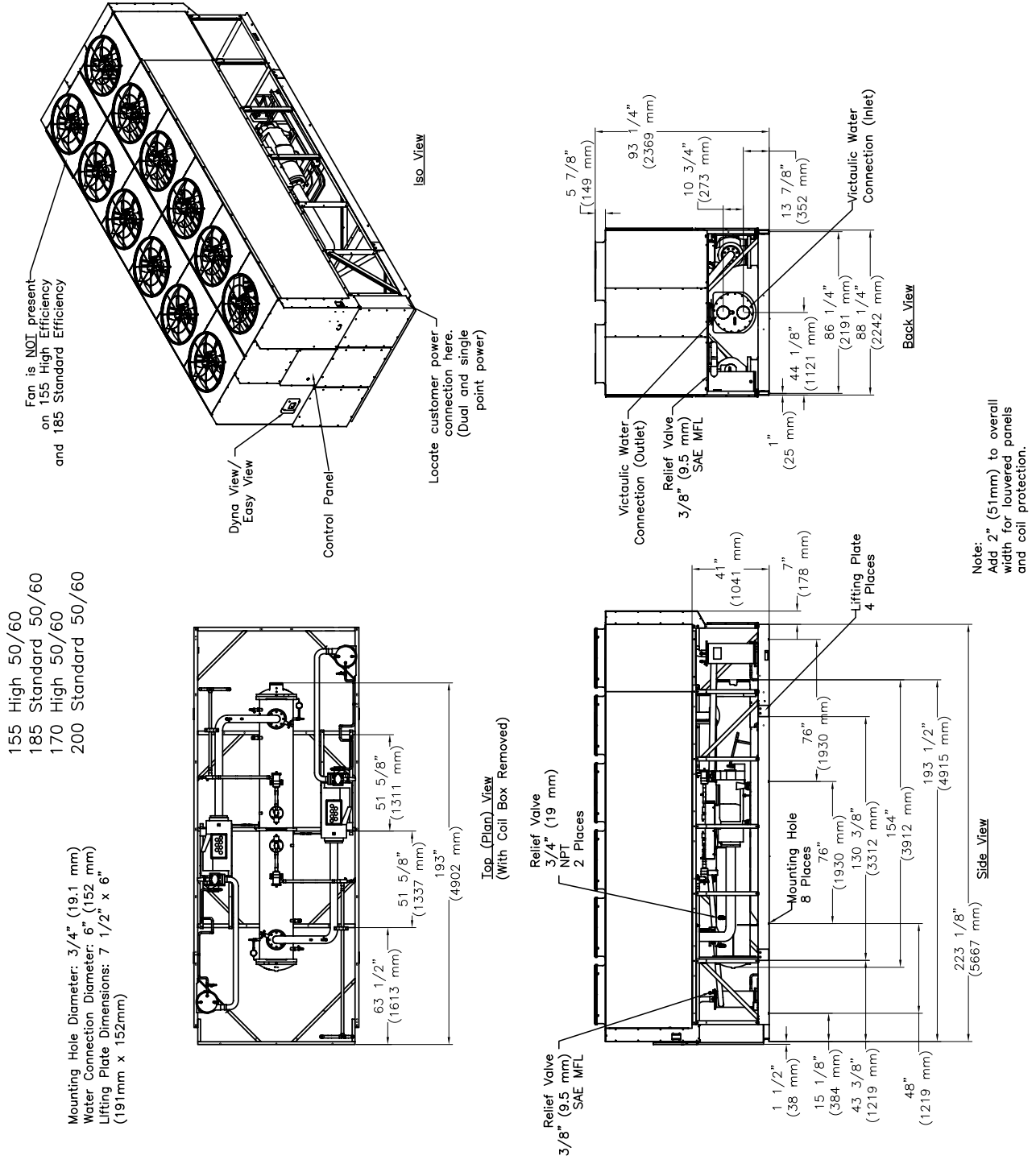


Figure 3 Unit Dimensions 185-200 Ton Standard Efficiency, 60 Hz and 155, 170 Ton, High Efficiency, 50 and 60 Hz

185 High 50/60  
 200 High 50/60  
 225 Standard 60  
 250 Standard 60

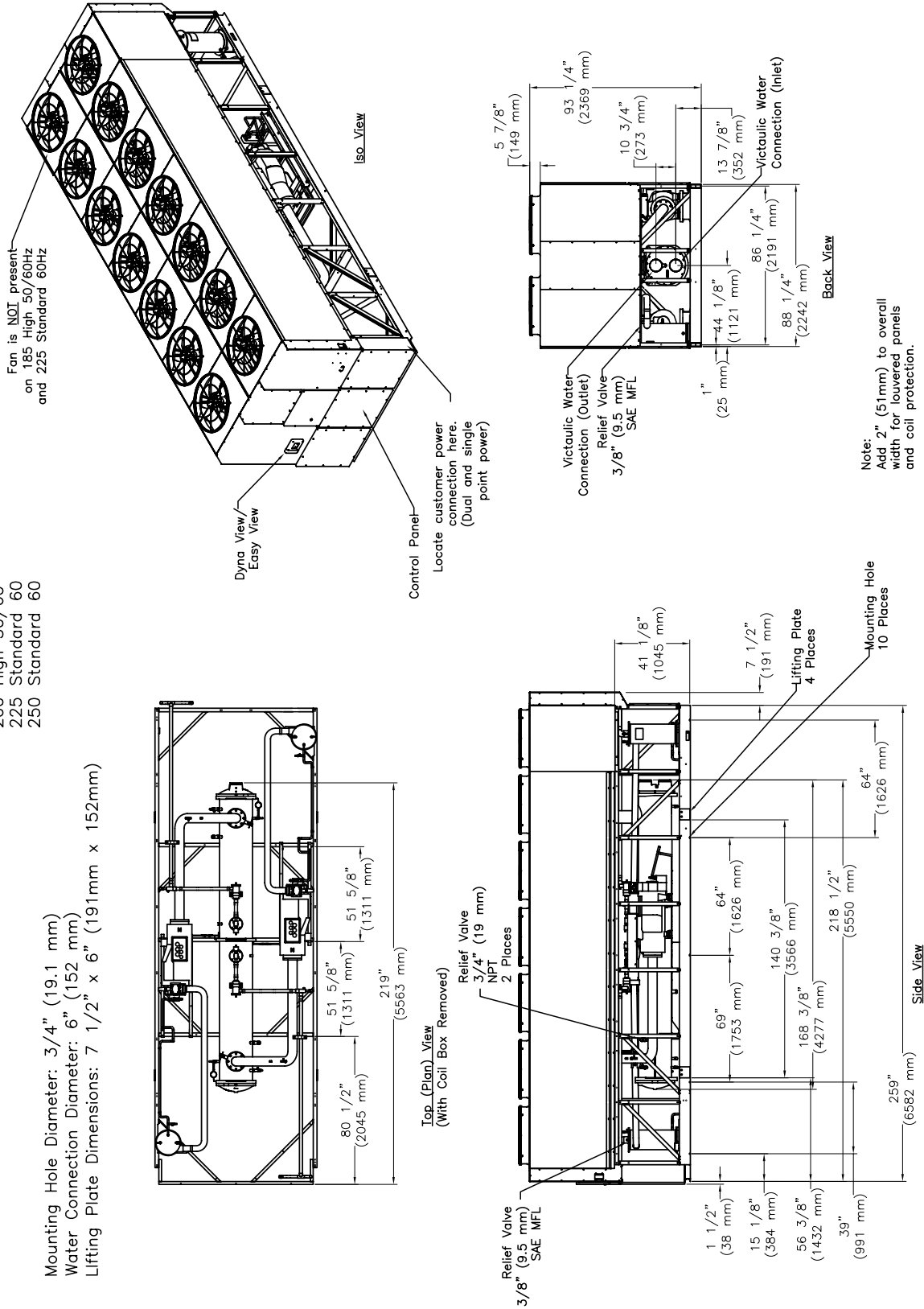


Figure 4 Unit Dimensions 225-250 Ton Standard Efficiency, 60 Hz and 185-200 Ton, High Efficiency, 50 and 60 Hz

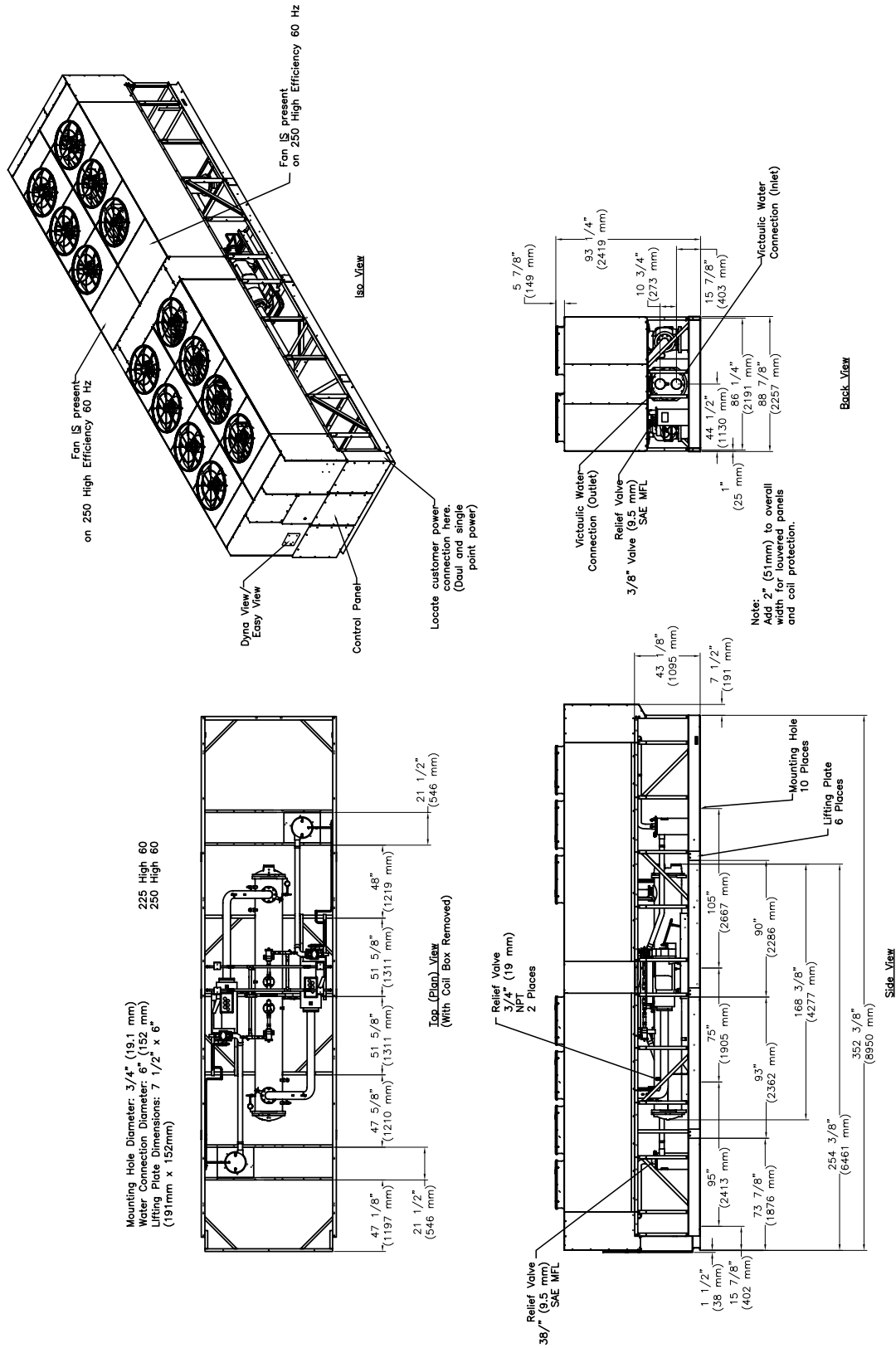


Figure 5 Unit Dimensions 225-250 Ton High Efficiency, 60 Hz

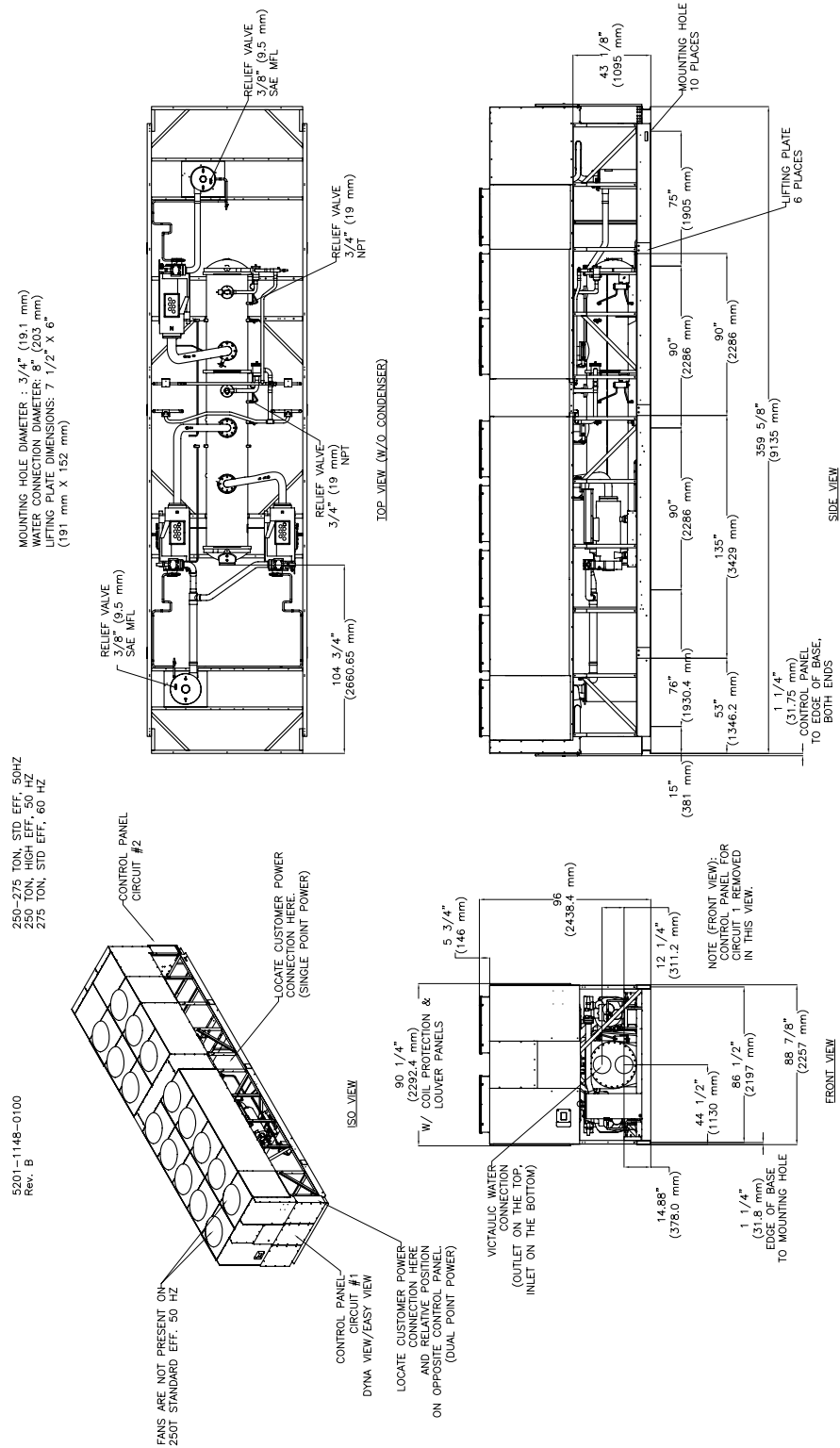


Figure 6 Unit Dimensions 250-275 Ton Standard Efficiency, 50 Hz and 250 Ton High Efficiency, 50 Hz and 275 Ton Standard Efficiency, 60 Hz

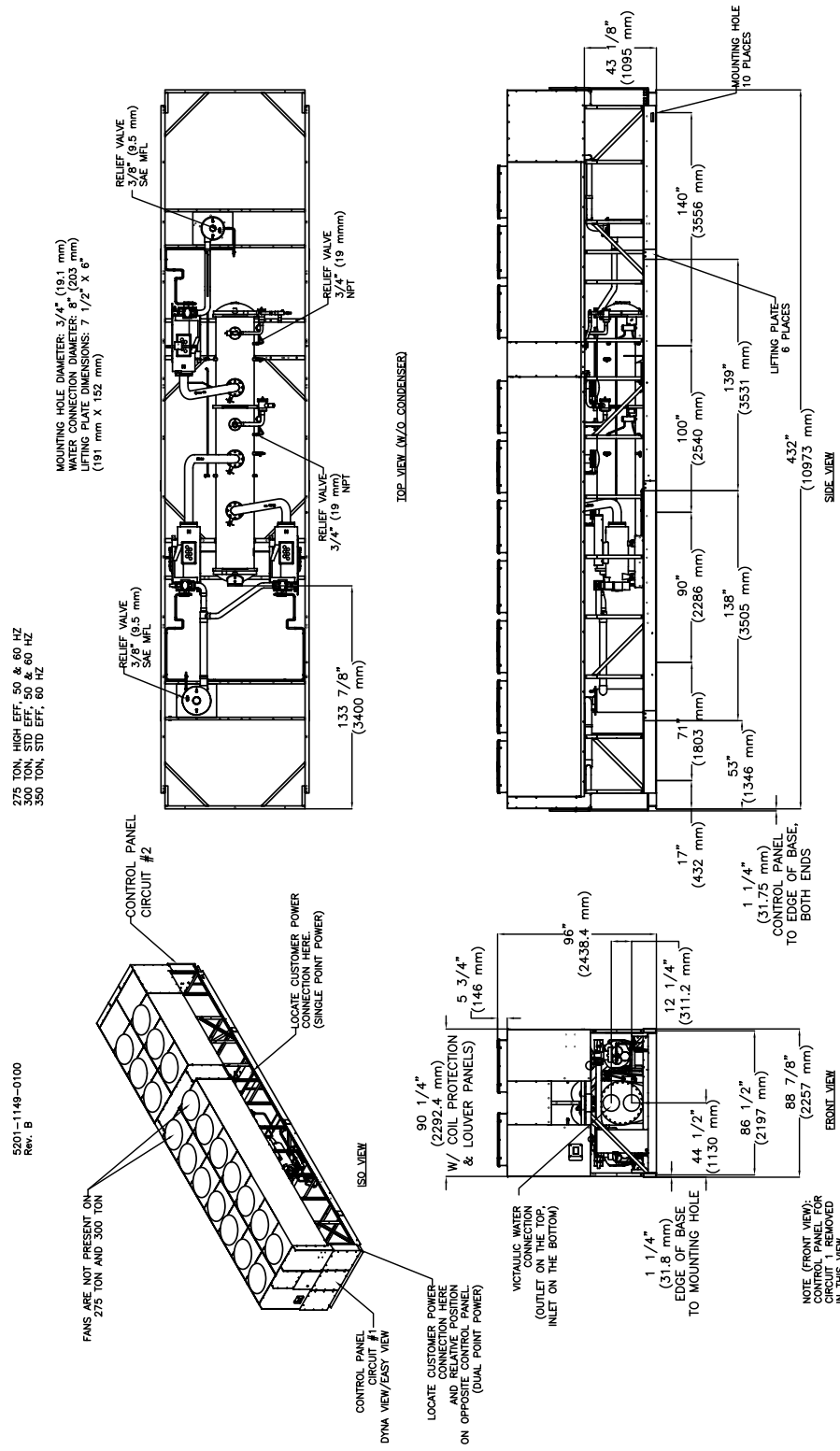


Figure 7 Unit Dimensions 275 Ton High Efficiency, 50 and 60 Hz; 300 Ton, Standard Efficiency, 50 and 60 Hz and 350 Ton, Standard Efficiency 60 Hz

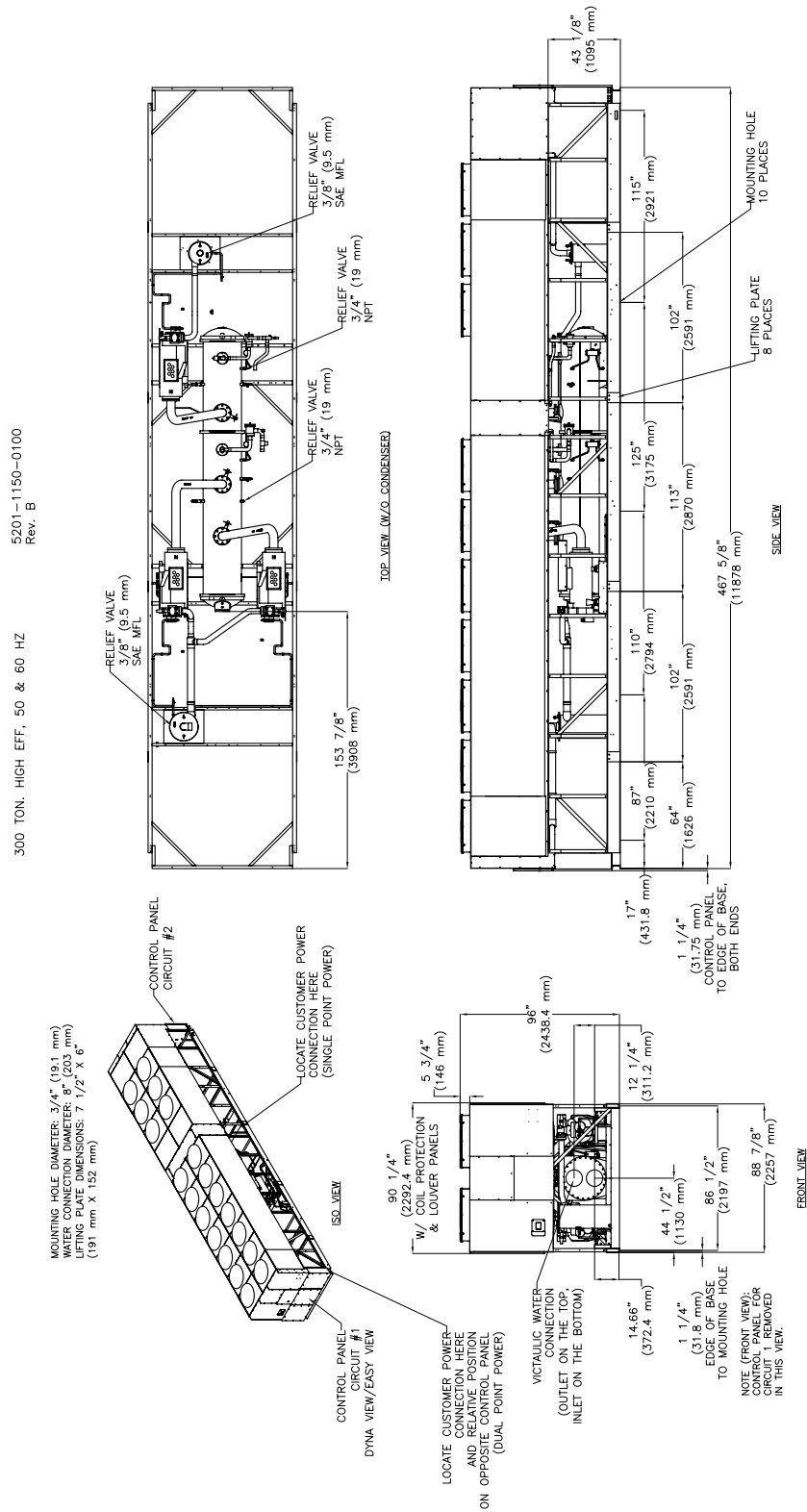


Figure 8 Unit Dimensions 300 Ton High Efficiency, 50 and 60 Hz

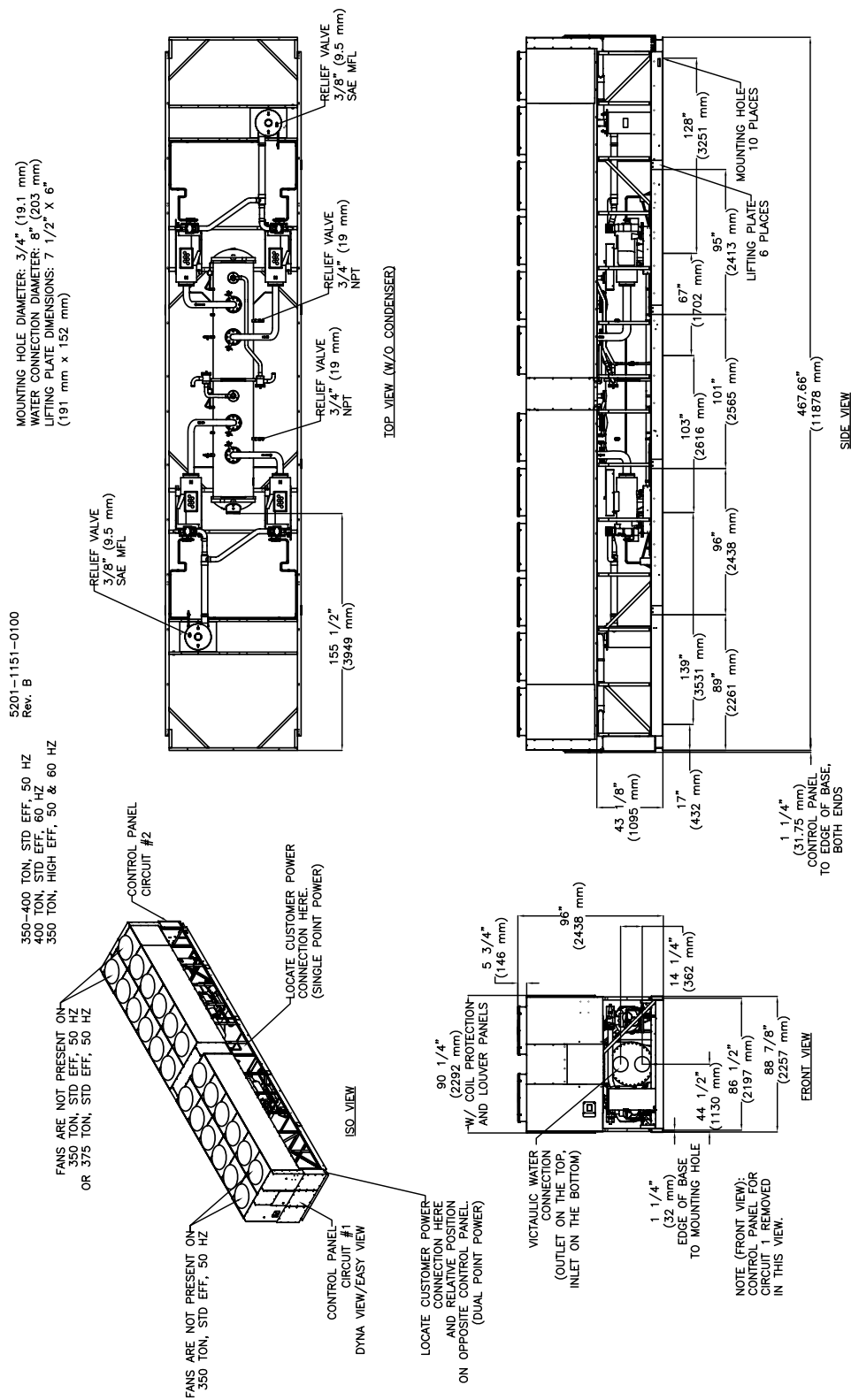


Figure 9 Unit Dimensions 350-400 Ton Standard Efficiency, Hz and 400 Ton, Standard Efficiency, 60 Hz and 350 Ton High Efficiency, 50 and 60Hz

5201-1152-0100  
Rev. B

MOUNTING HOLE DIAMETER: 3/4" (19.1 mm)  
WATER CONNECTION DIAMETER: 8" (203 mm)  
LIFTING PLATE DIMENSIONS: 7 1/2" X 6"  
(191 mm X 152 mm)

450-500 TON, STD. EFF, 60 HZ  
375-400 TON, HIGH EFF, 50 HZ  
400 TON, HIGH EFF, 60 HZ

FANS ARE NOT PRESENT ON:  
375 TON, HIGH EFF, 50 HZ OR  
400 TON, STD EFF, 60 HZ

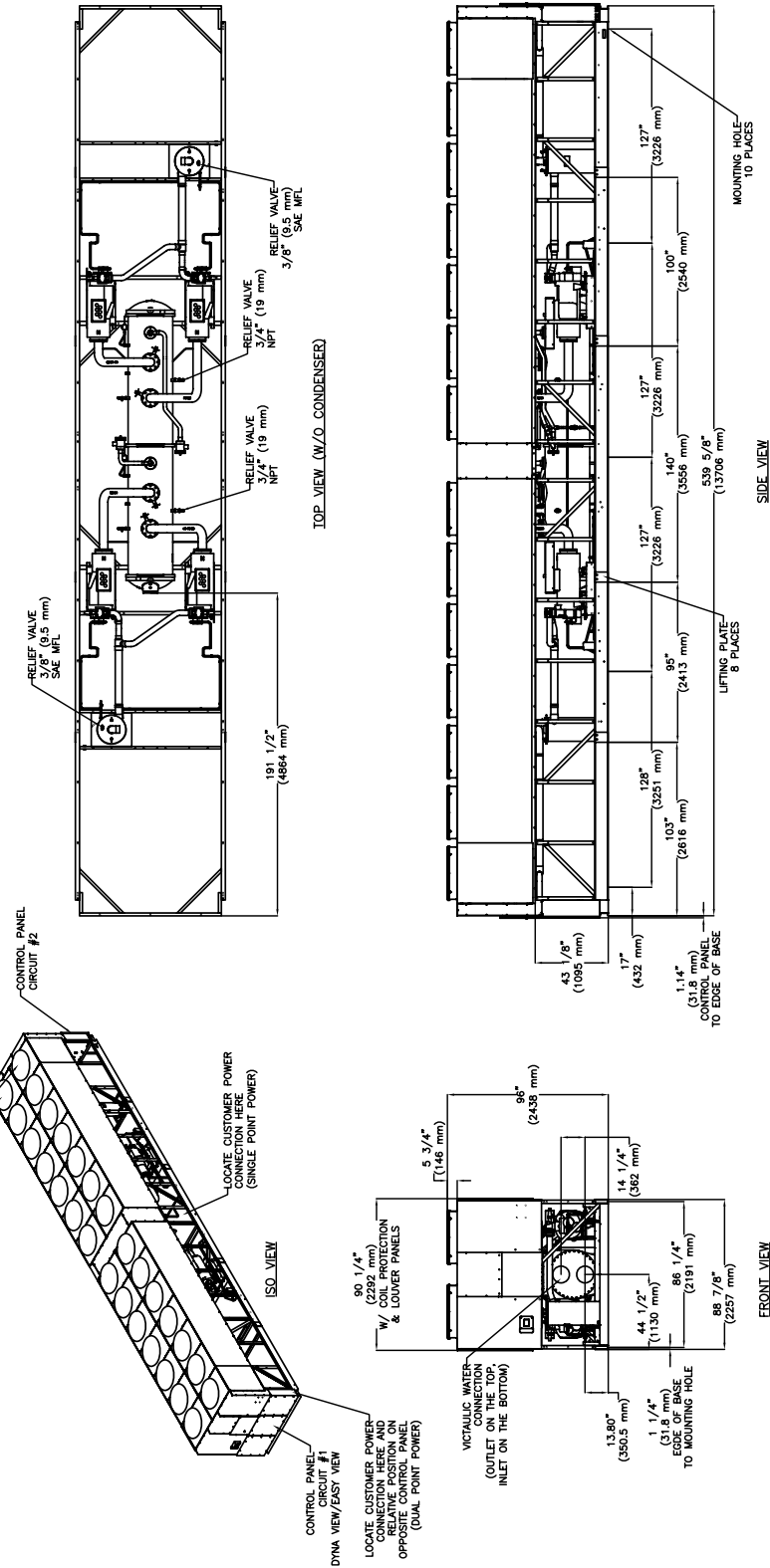
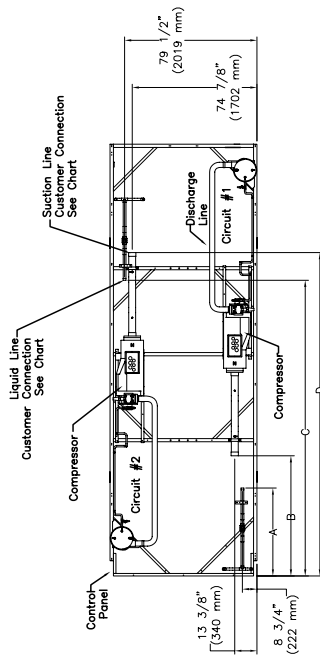


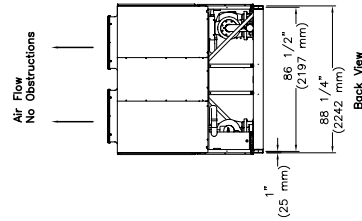
Figure 10 Unit Dimensions 450-500 Ton Standard Efficiency, 60 Hz and 375-400 Ton, High Efficiency, 50 Hz and 400 Ton High Efficiency, 60 Hz

Unit Size	A	B	C	D	E	F	G	H	I	J	K	L
140 Std	50 5/8"	52 5/8"	141 5/8"	143 5/8"	15"	46"	53"	53"	N/A	40 1/2"	109 1/2"	187"
155 Std	50 5/8"	52 5/8"	138 5/8"	143 5/8"	15"	46"	53"	53"	N/A	40 1/2"	109 1/2"	187"
170 Std	50 5/8"	54 5/8"	139 5/8"	143 5/8"	15"	46"	53"	53"	N/A	40 1/2"	109 1/2"	187"
140 High	50 5/8"	54 5/8"	139 5/8"	143 5/8"	15"	46"	53"	53"	N/A	40 1/2"	109 1/2"	187"
185 Std	56 3/8"	64 5/8"	177 1/2"	176"	15"	48"	76"	76"	N/A	46 1/2"	133 1/2"	223"
200 Std	54 1/4"	52 3/4"	177 1/2"	176"	15"	48"	76"	76"	N/A	46 1/2"	133 1/2"	223"
155 High	56 3/8"	64 5/8"	175 5/8"	173 3/4"	15"	48"	76"	76"	N/A	46 1/2"	133 1/2"	223"
170 High	56 3/8"	64 5/8"	175 5/8"	173 3/4"	15"	48"	76"	76"	N/A	46 1/2"	133 1/2"	223"
225 Std	72 1/4"	88 3/4"	213 1/2"	194"	15"	39"	69"	64"	64"	59 1/2"	143 1/2"	259"
185 High	74 3/8"	90 5/8"	213 1/2"	194"	15"	39"	69"	64"	64"	59 1/2"	143 1/2"	259"
250 Std	72 1/4"	82 3/4"	213 1/2"	194"	15"	39"	69"	64"	64"	59 1/2"	143 1/2"	259"
200 High	72 1/4"	82 3/4"	213 1/2"	194"	15"	39"	69"	64"	64"	59 1/2"	143 1/2"	259"

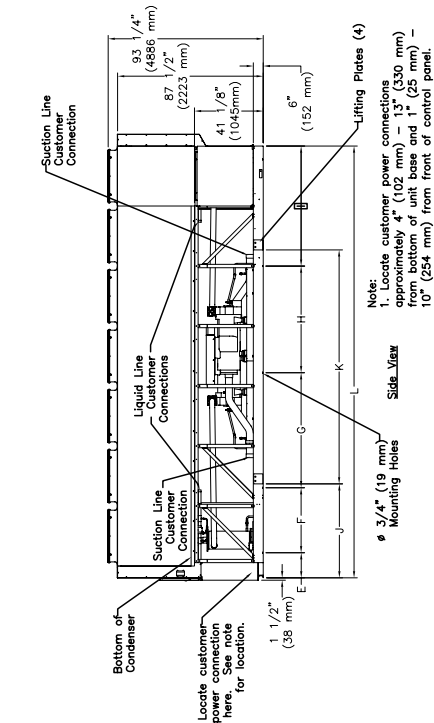
Unit Size	Suction Line (OD)		Liquid Line (OD)	
	Ckt #1	Ckt #2	Ckt #1	Ckt #2
140, 155 Std	3 5/8"	3 5/8"	1 3/8"	1 3/8"
170 Std	3 5/8"	3 5/8"	1 3/8"	1 3/8"
140 High	3 5/8"	3 5/8"	1 3/8"	1 3/8"
185 Std	4 1/8"	3 5/8"	1 5/8"	1 3/8"
200 Std	4 1/8"	4 1/8"	1 5/8"	1 5/8"
155, 170 High	3 5/8"	3 5/8"	1 3/8"	1 3/8"
225, 250 Std	4 1/8"	4 1/8"	1 5/8"	1 5/8"
185 High	4 1/8"	3 5/8"	1 5/8"	1 3/8"
200 High	4 1/8"	4 1/8"	1 5/8"	1 5/8"



Top (Plan) View

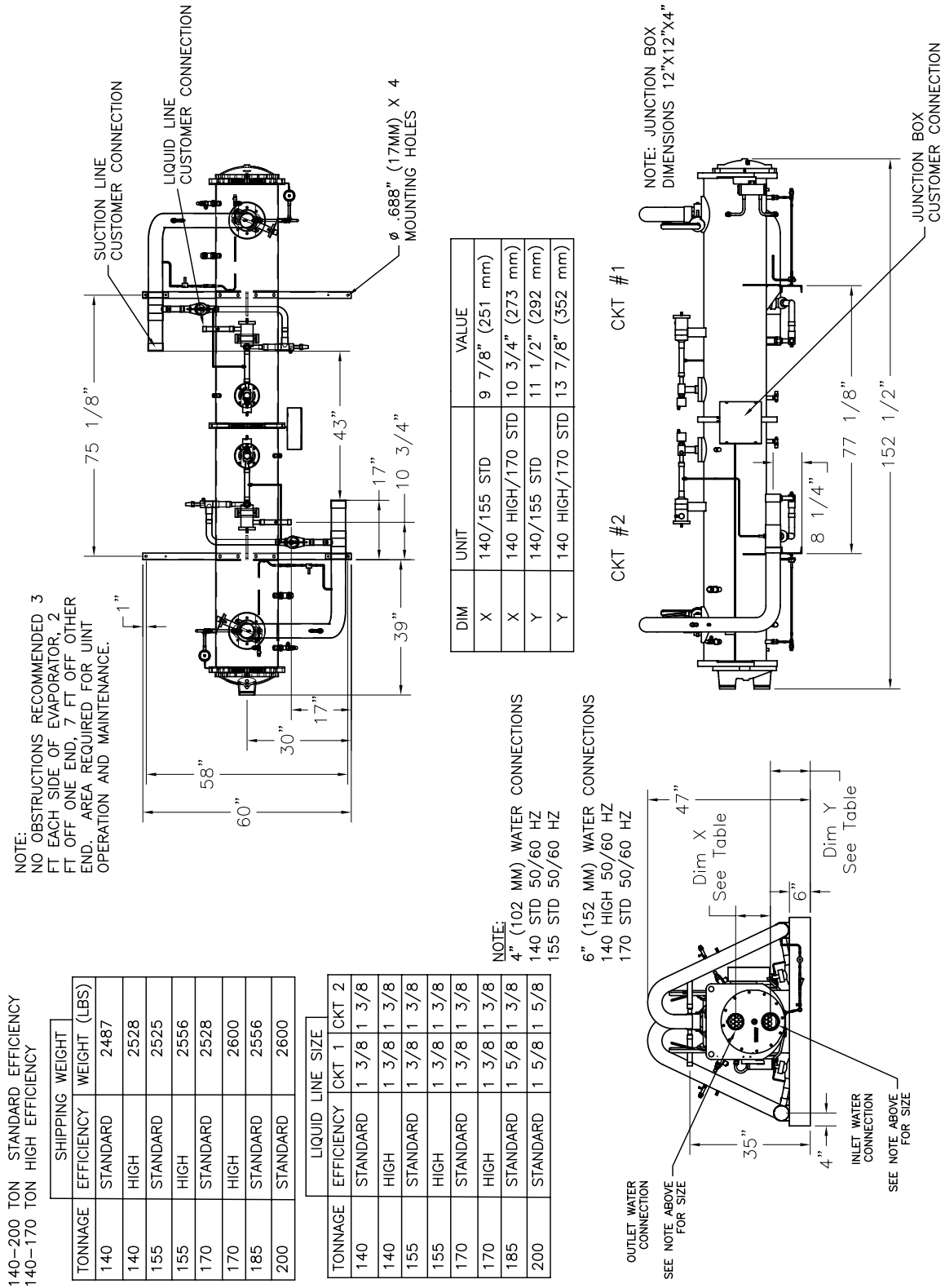


Back View



Side View

Figure 11 Unit Dimensions of Condenser/Compressor Unit for Remote Evaporator Option

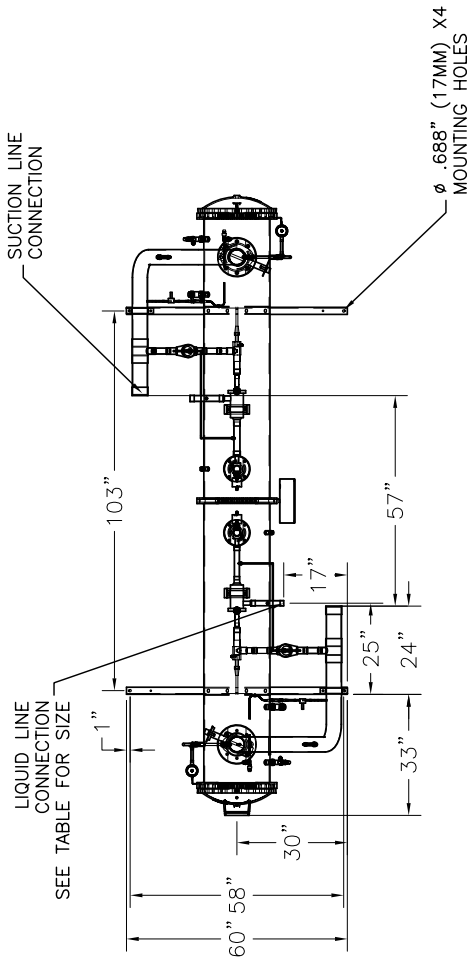


**Figure 12 Unit Dimensions for Remote Evaporator 140-170 Ton Standard Efficiency and 140 Ton High Efficiency**

225-250 TON STANDARD EFFICIENCY  
185-200 TON HIGH EFFICIENCY

TONNAGE	SHIPPING WEIGHT	
	EFFICIENCY	WEIGHT (LBS)
185	HIGH	2797
200	HIGH	2846
225	STANDARD	2797
250	STANDARD	2846

TONNAGE	LIQUID LINE SIZE	
	EFFICIENCY	CKT 1 CKT 2
185	HIGH	1 5/8 1 3/8
200	HIGH	1 5/8 1 5/8
225	STANDARD	1 5/8 1 5/8
250	STANDARD	1 5/8 1 5/8



CLEARANCES:  
NO OBSTRUCTIONS RECOMMENDED 3 FT EACH SIDE OF EVAPORATOR, 2 FT OFF ONE END, 9 FT OFF OTHER END. AREA REQUIRED FOR UNIT OPERATION AND MAINTENANCE.

NOTE: JUNCTION BOX DIMENSIONS 12"X12"X4"

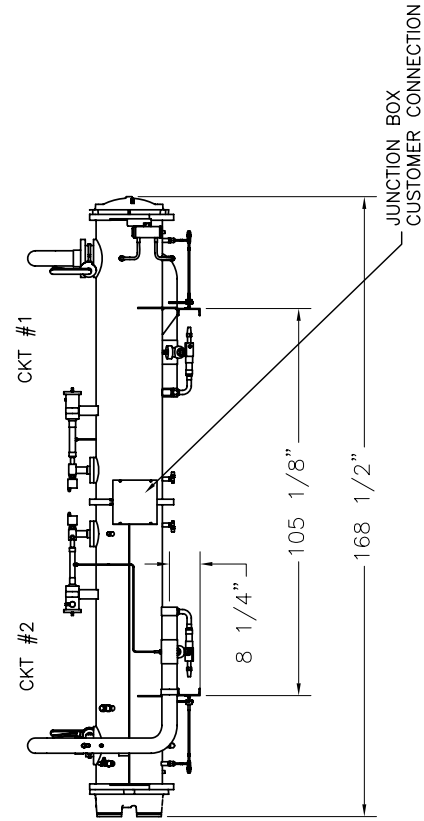
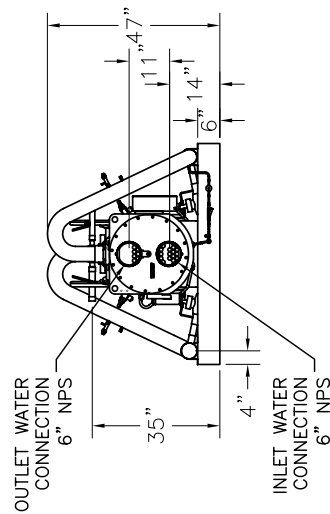


Figure 13 Unit Dimensions for Remote Evaporator 185-250 Ton Standard Efficiency and 155-200 Ton High Efficiency



## Model Number Coding System

The model numbers for the unit and the starter are composed of numbers and letters that represent features of the equipment. Shown in the following table is a sample of typical unit model number and the coding system for each.

Each position, or group of positions, in the model number is used to represent a feature. For example, in the first table, position 08 of the unit model number, Unit Voltage, contains the number "4". A 4 in this position means that the unit voltage is 460/60/3.

### Unit Model Number

An example of a typical unit model number (M/N) is:

RTAC 350A UA0N NAFN N1NX 1TEN NN0N N01N

Model number digits are selected and assigned in accordance with the following definitions using the model number example shown above.

**Digit 1-4****Unit Model**

RTAC Air Cooled Series R® chiller

**Digit 5-7****Unit Nominal Capacity**

140 140 Nominal Tons  
155 155 Nominal Tons  
170 170 Nominal Tons  
185 185 Nominal Tons  
200 200 Nominal Tons  
225 225 Nominal Tons  
250 250 Nominal Tons  
275 275 Nominal Tons  
300 300 Nominal Tons  
350 350 Nominal Tons  
375 375 Nominal Tons  
400 400 Nominal Tons  
450 450 Nominal Tons  
500 500 Nominal Tons

**Digit 8****Unit Voltage**

A 200V/60Hz/3Ph power  
K 220V/50Hz/3 Ph power  
C 230V/60Hz/3Ph power  
J 380V/60Hz/3Ph power  
D 400V/50Hz/3Ph power  
4 460V/60Hz/3Ph power  
5 575V/60Hz/3Ph power

**Digit 9****Manufacturing Location**

U Pueblo  
E Charmes

**Digit 10-11****Design Sequence**

XX Factory/ABU Assigned

**Digit 12****Unit Type**

N Std. Efficiency/Performance  
H High Efficiency/Performance

**Digit 13****Agency Listing**

N No agency listing  
U C/UL listing

**Digit 14****Pressure Vessel Code**

A ASME pressure vessel code  
C Canadian code  
D Australian code  
L Chinese code  
R Vietnamese code  
S Special

**Digit 15****Evaporator Temperature Range & Application Type**

F Standard Temp. with Frz Prot  
R Rem Evap, Std. Temp, No Frz Prot  
G Low Temp, with Frz Prot

**Digit 16****Evaporator Configuration**

N Standard pass arrangement, insulated

**Digit 17****Condenser Temperature Range**

N Standard ambient range  
25-115 deg F  
H High ambient capability  
25-125 deg F  
L Low ambient capability  
0-115 deg F  
W Wide ambient capability  
0-125 deg F

**Digit 18****Condenser Fin Material**

1 Standard aluminum slit fins  
2 Copper fins, non-slit fins  
4 Complete Coat aluminum fins

**Digit 19****Condenser Fan/Motor Configuration**

N Condenser fans with ODP motors  
W Low Noise fans  
T Condenser fans with TEAO motors

**Digit 20****Compressor Motor Starter Type**

X Across-the-line starters  
Y Wye-delta closed transition starters

**Digit 21****Incoming Power Line Connection**

1 Single point power connection  
2 Dual point power connection (1/ dkt)

**Digit 22****Power Line Connection Type**

T Terminals only  
D Non-fused disconnect switch(es)  
C Circuit Breaker(s), HACR-rated

**Digit 23****Unit Operator Interface**

E Easy-View operator interface  
D Dyna-View operator interface

**Digit 24****Remote Interface**

N No remote interface  
C Tracer Comm 3 interface  
L Lon Talk Communication interface (LCI)

**Digit 25****Control Input Accessories/Options**

N No remote input  
R Remote leaving water temp stpt  
C Remote current limit setpoint  
B Remote lvg. temp.setpoint and remote current limit setpoint

**Digit 26****COOP****26****Control Output Accessories/Options**

N No output options  
A Alarm relay  
C Icemaking  
D Icemaking and alarm relay

**Digit 27****Short Circuit Rating**

0 No short circuit withstand rating  
5 10000A SCR  
4 35000A SCR  
6 65000A SCR

**Digit 28****Electrical Accessories and Export Packing**

N No flow switches  
F NEMA-1 flow switch - 150 psi  
E Vapor Proof FS - 150 psi

**Digit 29****Control Panel Accessories**

N No convenience outlet  
A 15A 115V convenience outlet (60HZ)

**Digit 30****Refrigerant Service Valves**

1 Suction service valves

**Digit 31****Compressor Sound Attenuator Option**

0 No sound attenuator  
1 Factory installed sound attenuator

**Digit 32****Appearance Options**

N No appearance options  
A Architectural louvered panels  
C Half Louvers  
G Access guards  
B Access guards and half louvers  
P Painted unit  
L Painted unit with full louvered panels  
H Painted unit with half louvered panels  
K Painted unit with access guards  
W Painted w/access guards and half louvers

**Digit 33****Installation Accessories**

N No installation accessories  
R Neoprene isolators  
F Flanged water connection kit  
G Neoprene isolators and flange wtr conn kit

**Digit 34****Factory Test**

0 No factory run test  
P Performance test  
W Witness test

**Digit 35****Label, and Literature Language**

E English  
G Chinese

**Digit 36****Special Order**

X Standard catalog configuration  
S Unit has special order feature

**Digit 37****Safety Devices**

N None  
X Standard



## Installation - Mechanical

---

### Installation Responsibilities

Generally, the contractor must do the following when installing an RTAC unit:

- Install unit on a flat foundation, level (within 1/4" [6 mm] across the length and width of the unit), and strong enough to support unit loading.
- Install unit per the instructions contained in the Installation-Mechanical and Installation-Electrical sections of this manual.
- Install any optional sensors and make electrical connections at the CH530.
- Where specified, provide and install valves in water piping upstream and downstream of evaporator water connections to isolate the evaporator for maintenance, and to balance/trim system.
- Furnish and install flow switch to prove chilled water flow.
- Furnish and install pressure gauges in inlet and outlet piping of the evaporator.
- Furnish and install a drain valve to the bottom of the evaporator waterbox.
- Supply and install a vent cock to the top of the evaporator waterbox.
- Furnish and install strainers ahead of all pumps and automatic modulating valves, and at inlet of evaporator.
- Provide and install field wiring.
- Install heat tape and insulate the chilled water lines and any other portions of the system, as required, to prevent sweating under normal operating conditions or freezing during low ambient temperature conditions.
- Install evaporator drain plug. The plug ships in unit control panel.
- Start unit under supervision of a qualified service technician.

### Nameplates

The RTAC outdoor unit nameplates ([Figure 1](#)) are applied to the exterior of the Control Panel. A compressor nameplate is located on each compressor.

#### Outdoor Unit Nameplate

The outdoor unit nameplate provides the following information:

- Unit model and size description.
- Unit serial number.
- Identifies unit electrical requirements.
- Lists correct operating charges of R-134a and refrigerant oil (Trane OIL00048).
- Lists unit test pressures.
- Identifies installation, operation and maintenance and service data literature (Pueblo).
- Lists drawing numbers for unit wiring diagrams (Pueblo).

#### Compressor Nameplate

The compressor nameplate provides following information:

- Compressor model number.
- Compressor serial number.
- Compressor electrical characteristics.
- Utilization range.
- Recommended refrigerant.

# Installation - Mechanical

## Storage

Extended storage of the outdoor unit prior to installation requires the following precautionary measures:

1. Store the outdoor unit in a secure area.
2. At least every three months (quarterly), check the pressure in the refrigerant circuits to verify that the refrigerant charge is intact. If it is not, contact a qualified service organization and the appropriate Trane sales office.
3. Close the discharge and liquid line isolation valves.

## General

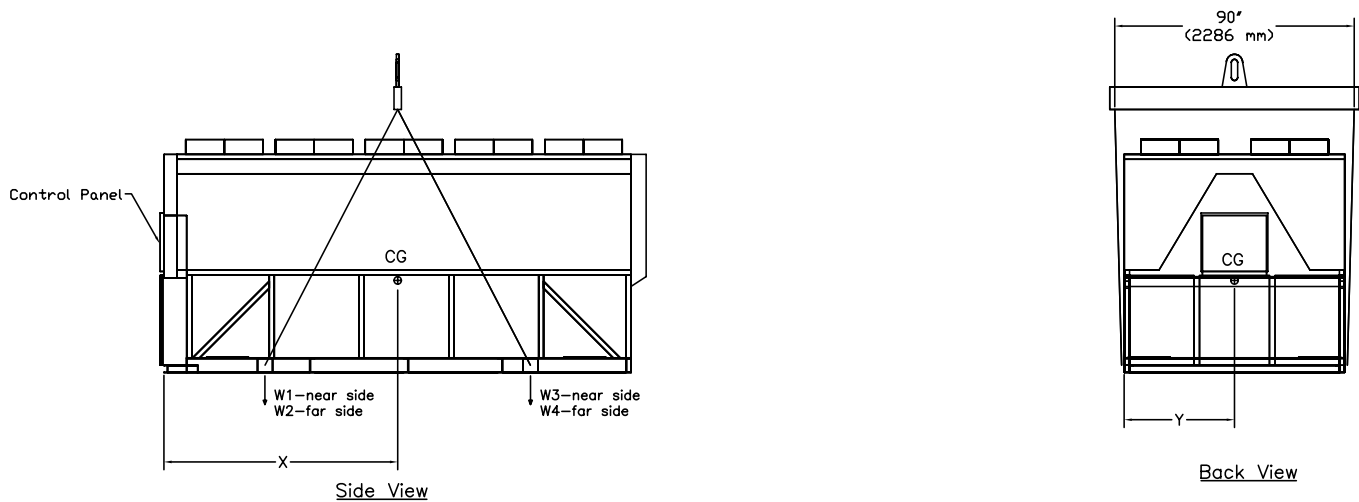
Report any damage incurred during handling or installation to the Trane sales office immediately.

## Location Requirements

### Setting the Unit

A base or foundation is not required if the selected unit location is level and strong enough to support the unit's operating weight as listed in [Table 1](#) through [Table 5](#) in the General Information section.

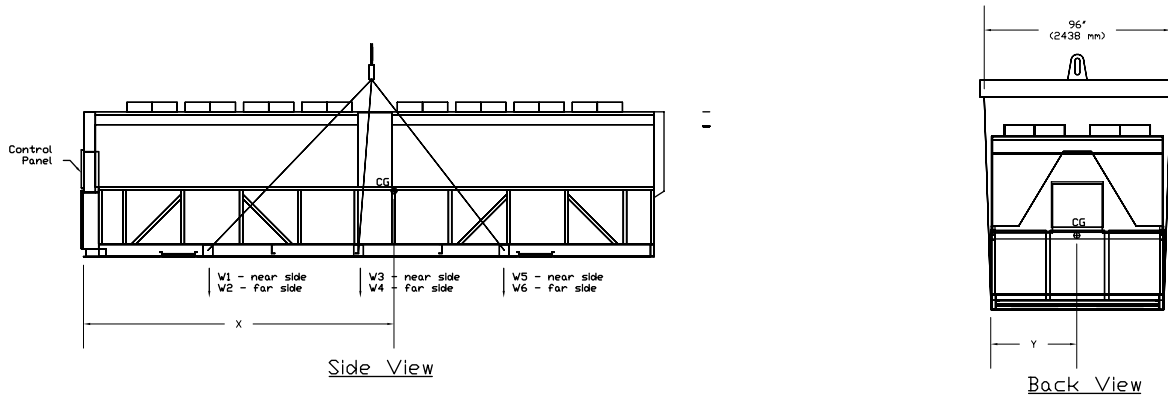
See [Table 6](#) for lifting weights and center of gravity (CG) dimensions.



1. Lifting chains/cables will not be the same length. Adjust to keep unit level while lifting.
2. Do not fork lift unit.
3. Weights are typical for units with R-134a charge.

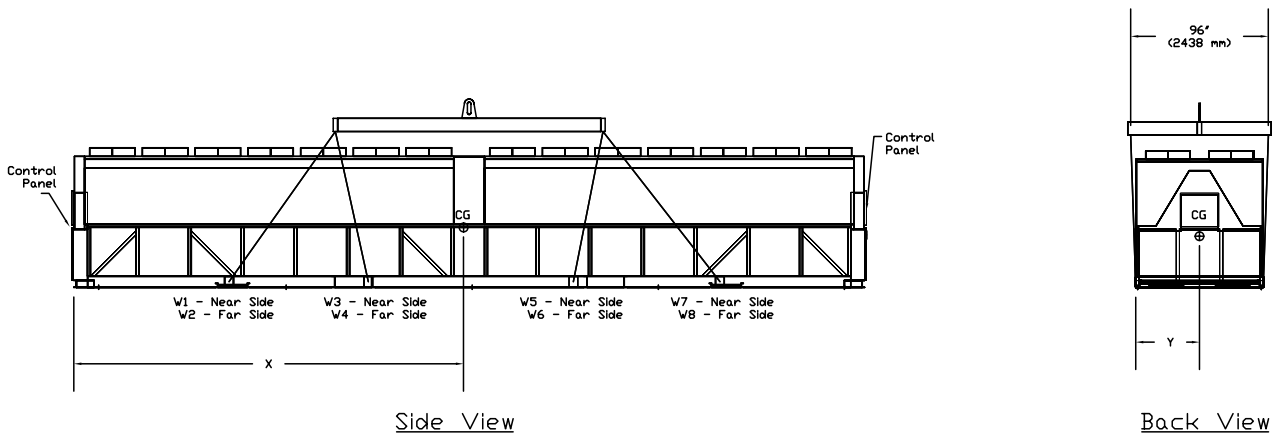
**Figure 14 Lifting the Unit (Package and Remote) 15-21-foot Base**

# Installation - Mechanical



1. Lifting chains/cables will not be the same length. Adjust to keep unit level while lifting.
2. Do not fork lift unit.
3. Weights are typical for units with R-134a charge.

**Figure 15 Lifting the Unit (Package and Remote) 30-36-foot Base**



1. Lifting chains/cables will not be the same length. Adjust to keep unit level while lifting.
2. Do not fork lift unit.
3. Weights are typical for units with R-134a charge.

**Figure 16 Lifting the Unit 39-45-foot Base**



# Installation - Mechanical

**Table 6** Lifting Weights and CG Dimensions (Refer to Figure 14 - Figure 15)

Unit	W1	W2	W3	W4	W5	W6	W7	W8	Shipping Weight	Xcg	Ycg
	lbs kg	lbs kg	lbs kg	lbs kg	lbs kg	lbs kg	lbs kg	lbs kg	lbs kg	in mm	in mm
<b>Aluminum Fins</b>											
140 Ton 50 Hz High Eff	2499 1134	2874 1303	2686 1218	3019 1369	NA	NA	NA	NA	11077 5025	88 2245	45 1140
140 Ton 50 Hz Std Eff	2488 1128	2859 1297	2668 1210	3000 1361	NA	NA	NA	NA	11015 4996	88 2245	45 1140
140 Ton 60 Hz High Eff	2495 1132	2869 1301	2680 1216	3013 1367	NA	NA	NA	NA	11057 5015	88 2245	45 1140
140 Ton 60 Hz Std Eff	2484 1127	2855 1295	2662 1208	2994 1358	NA	NA	NA	NA	10995 4987	88 2243	45 1140
155 Ton 50 Hz High Eff	3281 1488	3588 1628	2747 1246	3055 1386	NA	NA	NA	NA	12671 5748	106 2695	44 1123
155 Ton 50 Hz Std Eff	2601 1180	2882 1307	2794 1267	3033 1376	NA	NA	NA	NA	11309 5130	88 2243	44 1120
155 Ton 60 Hz High Eff	3168 1437	3562 1616	2604 1181	2998 1360	NA	NA	NA	NA	12332 5594	106 2682	45 1140
155 Ton 60 Hz Std Eff	2493 1131	2862 1298	2675 1213	3004 1362	NA	NA	NA	NA	11034 5005	88 2245	45 1138
170 Ton 50 Hz High Eff	3308 1501	3721 1688	2760 1252	3173 1439	NA	NA	NA	NA	12962 5880	106 2695	45 1140
170 Ton 50 Hz Std Eff	2598 1179	2990 1356	2838 1287	3177 1441	NA	NA	NA	NA	11603 5263	89 2256	45 1138
170Ton 60 Hz High Eff	3186 1445	3586 1627	2623 1190	3024 1371	NA	NA	NA	NA	12418 5633	106 2685	45 1140
170 Ton 60 Hz Std Eff	2498 1133	2873 1303	2684 1218	3018 1369	NA	NA	NA	NA	11073 5023	88 2245	45 1140
185 Ton 50 Hz High Eff	3650 1655	4199 1905	3113 1412	3662 1661	NA	NA	NA	NA	14624 6633	124 3160	45 1153
185 Ton 50 Hz Std Eff	3342 1516	3763 1707	2745 1245	3166 1436	NA	NA	NA	NA	13015 5904	106 2682	45 1140
185 Ton 60 Hz High Eff	3526 1600	4117 1867	2990 1356	3581 1624	NA	NA	NA	NA	14214 6447	124 3157	46 1161
185 Ton 60 Hz Std Eff	3296 1495	3635 1649	2707 1228	3047 1382	NA	NA	NA	NA	12685 5754	106 2680	44 1128
200 Ton 50 Hz High Eff	3778 1714	4252 1928	3175 1440	3649 1655	NA	NA	NA	NA	14853 6737	124 3147	45 1140
200 Ton 50 Hz Std Eff	3370 1529	3789 1719	2828 1283	3247 1473	NA	NA	NA	NA	13234 6003	106 2697	45 1138
200 Ton 60 Hz High Eff	3719 1687	4187 1899	3110 1411	3578 1623	NA	NA	NA	NA	14593 6619	124 3142	45 1140
200 Ton 60 Hz Std Eff	3340 1515	3756 1704	2796 1268	3212 1457	NA	NA	NA	NA	13104 5944	106 2697	45 1138
225 Ton 60 Hz Std Eff	3711 1683	4229 1918	3114 1413	3632 1648	NA	NA	NA	NA	14687 6662	124 3147	45 1148
250 Ton 60 Hz Std Eff	3778 1714	4252 1928	3175 1440	3649 1655	NA	NA	NA	NA	14853 6737	124 3147	45 1140
250 Ton 50 Hz High Eff	3360 1526	2930 1330	3390 1539	2959 1344	3430 1557	3000 1362	NA	NA	19069 8657	177 4483	41 1052
250 Ton 50 Hz Std Eff	2951 1340	2522 1145	3238 1470	2809 1275	3430 1557	3000 1362	NA	NA	17949 8149	182 4623	41 1046
275 Ton 50 Hz High Eff	3403 1545	2997 1361	3689 1675	3283 1491	3977 1805	3571 1621	NA	NA	20920 9498	202 5128	42 1064



# Installation - Mechanical

**Table 6 Lifting Weights and CG Dimensions (Refer to Figure 14 - Figure 15)**

Unit	W1	W2	W3	W4	W5	W6	W7	W8	Shipping Weight	Xcg	Ycg
	lbs kg	lbs kg	lbs kg	lbs kg	lbs kg	lbs kg	lbs kg	lbs kg	lbs kg	in mm	in mm
275 Ton 50 Hz Std Eff	3668	3194	3478	3004	3356	2877	NA	NA	19577	172	41
	1665	1450	1579	1364	1524	1306	NA	NA	8888	4376	1046
275 Ton 60 Hz High Eff	3251	2863	3571	3183	3894	3505	NA	NA	20266	203	42
	1476	1300	1621	1445	1768	1591			9201	5159	1064
275 Ton 60 Hz Std Eff	3345	2936	3351	2942	3356	2947	NA	NA	18876	176	42
	1518	1333	1521	1336	1523	1338			8570	4473	1057
300 Ton 50 Hz High Eff	2955	2628	2892	2565	2822	2495	2759	2432	21548	222	42
	1342	1193	1313	1164	1281	1133	1253	1104	9783	5644	1059
300 Ton 50 Hz Std Eff	3328	2917	3564	3153	3802	3393	NA	NA	20314	201	42
	1511	1394	1618	1431	1726	1540			9222	5100	1059
300 Ton 60 Hz High Eff	2955	2628	2892	2565	2782	2495	2759	2432	21508	222	42
	1342	1193	1313	1165	1263	1133	1253	1104	9765	5641	1062
300 Ton 60 Hz Std Eff	3456	3074	3615	3233	3774	3393	NA	NA	19572	199	42
	1569	1396	1641	1468	1713	1540			8886	5044	1067
350 Ton 50 Hz High Eff	3278	3258	3179	3159	3075	3055	2977	2957	24936	234	44
	1488	1479	1443	1434	1396	1387	1352	1342	11321	5951	1125
350 Ton 50 Hz Std Eff	3018	2998	2933	2914	2844	2824	2760	2740	23031	235	44
	1370	1361	1332	1323	1291	1282	1253	1244	10456	5956	1125
350 Ton 60 Hz High Eff	3140	3123	3038	3020	2930	2912	2828	2811	23803	234	44
	1426	1418	1379	1371	1330	1322	1284	1276	10806	5941	1125
350 Ton 60 Hz Std Eff	3374	2998	3772	3367	4172	3767	NA	NA	21450	205	42
	1532	1361	1712	1529	1894	1710			9738	5197	1064
375 Ton 50 Hz High Eff	3393	3372	3278	3257	3108	3086	2986	2965	25444	266	44
	1541	1531	1488	1478	1411	1401	1356	1346	11552	6754	1125
375 Ton 50 Hz Std Eff	3328	3296	3116	3083	2892	2859	2681	2649	23903	229	44
	1511	1496	1414	1400	1313	1298	1217	1202	10852	5827	1123
400 Ton 50 Hz High Eff	3345	3271	3377	3303	3425	3350	3458	3384	26912	274	44
	1519	1485	1533	1499	1555	1521	1570	1536	12218	6957	1115
400 Ton 50 Hz Std Eff	3299	3279	3201	3180	3098	3077	3001	2939	25073	234	44
	1498	1488	1453	1444	1406	1397	1362	1334	11383	5951	1125
400 Ton 60 Hz High Eff	3345	3271	3377	3303	3425	3350	3458	3384	26913	274	44
	1519	1485	1533	1500	1555	1521	1570	1536	12219	6955	1118
400 Ton 60 Hz Std Eff	3299	3279	3201	3180	3098	3077	3001	2939	25074	234	44
	1498	1489	1453	1444	1406	1397	1362	1334	11383	5951	1125
450 Ton 60 Hz Std Eff	3423	3402	3307	3286	3137	3116	3015	2994	25678	266	44
	1554	1544	1501	1492	1424	1414	1369	1359	11658	6754	1125
500 Ton 60 Hz Std Eff	3363	3289	3395	3321	3442	3368	3476	3402	27056	274	44
	1527	1493	1541	1508	1563	1529	1578	1544	12283	6955	1115
<b>Copper Fins</b>											
140 Ton 50 Hz High Eff	2972	3464	3410	3805	NA	NA	NA	NA	13651	90	45
	1348	1571	1547	1726					6192	2289	1140
140 Ton 50 Hz Std Eff	2961	3450	3392	3786	NA	NA	NA	NA	13589	90	45
	1343	1565	1539	1717					6164	2286	1140
140 Ton 60 Hz High Eff	2969	3460	3404	3799	NA	NA	NA	NA	13631	90	45
	1347	1569	1544	1723					6183	2289	1140
140 Ton 60 Hz Std Eff	2957	3445	3386	3780	NA	NA	NA	NA	13569	90	45
	1341	1563	1536	1715					6155	2286	1140
155 Ton 50 Hz High Eff	4027	4454	3591	4018	NA	NA	NA	NA	16091	108	44
	1827	2020	1629	1823					7299	2743	1128
155 Ton 50 Hz Std Eff	3074	3472	3518	3819	NA	NA	NA	NA	13883	90	44
	1394	1575	1596	1732					6297	2286	1125
155 Ton 60 Hz High Eff	3915	4428	3448	3961	NA	NA	NA	NA	15752	108	45
	1776	2009	1564	1797					7145	2736	1140



# Installation - Mechanical

**Table 6 Lifting Weights and CG Dimensions (Refer to Figure 14 - Figure 15)**

Unit	W1	W2	W3	W4	W5	W6	W7	W8	Shipping Weight	Xcg	Ycg
	lbs kg	lbs kg	lbs kg	lbs kg	lbs kg	lbs kg	lbs kg	lbs kg	lbs kg	in mm	in mm
155 Ton 60 Hz Std Eff	2967	3453	3399	3790	NA	NA	NA	NA	13608	90	45
	1346	1566	1542	1719					6173	2286	1140
170 Ton 50 Hz High Eff	4055	4587	3604	4136	NA	NA	NA	NA	16382	108	45
	1839	2081	1635	1876					7431	2743	1140
170 Ton 50 Hz Std Eff	3071	3581	3562	3963	NA	NA	NA	NA	14177	90	45
	1393	1624	1616	1798					6431	2296	1140
170Ton 60 Hz High Eff	3932	4452	3467	3987	NA	NA	NA	NA	15838	108	45
	1784	2019	1573	1808					7184	2738	1140
170 Ton 60 Hz Std Eff	2972	3463	3409	3804	NA	NA	NA	NA	13647	90	45
	1348	1571	1546	1725					6190	2289	1140
185 Ton 50 Hz High Eff	4585	5283	4161	4860	NA	NA	NA	NA	18889	126	45
	2080	2396	1888	2204					8568	3211	1151
185 Ton 50 Hz Std Eff	4088	4629	3589	4129	NA	NA	NA	NA	16435	108	45
	1854	2100	1628	1873					7455	2733	1140
185 Ton 60 Hz High Eff	4462	5201	4039	4778	NA	NA	NA	NA	18479	126	46
	2024	2359	1832	2167					8382	3211	1158
185 Ton 60 Hz Std Eff	4042	4501	3551	4010	NA	NA	NA	NA	16105	108	45
	1834	2042	1611	1819					7305	2733	1133
200 Ton 50 Hz High Eff	4713	5336	4223	4846	NA	NA	NA	NA	19118	126	45
	2138	2420	1916	2198					8672	3200	1140
200 Ton 50 Hz Std Eff	4116	4654	3672	4211	NA	NA	NA	NA	16654	108	45
	1867	2111	1666	1910					7554	2746	1140
200 Ton 60 Hz High Eff	4654	5271	4158	4775	NA	NA	NA	NA	18858	126	45
	2111	2391	1886	2166					8554	3198	1140
200 Ton 60 Hz Std Eff	4087	4622	3640	4175	NA	NA	NA	NA	16524	108	45
	1854	2097	1651	1894					7495	2746	1140
225 Ton 60 Hz Std Eff	4646	5313	4163	4830	NA	NA	NA	NA	18952	126	45
	2108	2410	1888	2191					8597	3200	1146
250 Ton 60 Hz Std Eff	4713	5336	4223	4846	NA	NA	NA	NA	19118	126	45
	2138	2420	1916	2198					8672	3200	1140
250 Ton 50 Hz High Eff	4303	3872	4188	3756	4111	3679	NA	NA	23909	174	42
	1954	1758	1901	1705	1866	1670			10855	4422	1067
250 Ton 50 Hz Std Eff	3534	3104	3918	3488	4174	3744	NA	NA	21962	183	42
	1605	1409	1779	1583	1895	1700			9971	4638	1062
275 Ton 50 Hz High Eff	4366	3959	4618	4211	4872	4465	NA	NA	26492	200	42
	1982	1797	2097	1912	2212	2027			12027	5070	1077
275 Ton 50 Hz Std Eff	4611	4136	4276	3801	4057	3577	NA	NA	24458	171	42
	2093	1878	1941	1725	1842	1624			11104	4338	1062
275 Ton 60 Hz High Eff	4214	3877	4501	4111	4789	4399	NA	NA	25891	201	42
	1913	1760	2043	1866	2174	1997			11754	5093	1077
275 Ton 60 Hz Std Eff	4287	3877	4149	3739	4057	3647	NA	NA	23758	174	42
	1946	1760	1884	1698	1842	1656			10786	4415	1069
300 Ton 50 Hz High Eff	3836	3508	3689	3360	3526	3197	3379	3050	27544	220	42
	1742	1592	1675	1526	1601	1451	1534	1385	12505	5575	1074
300 Ton 50 Hz Std Eff	4360	3948	4476	4064	4593	4182	NA	NA	25623	197	42
	1980	1792	2032	1845	2085	1899			11633	4999	1074
300 Ton 60 Hz High Eff	3799	3508	3689	3360	3526	3197	3379	3050	27508	219	42
	1725	1593	1675	1525	1601	1451	1534	1385	12489	5573	1074
300 Ton 60 Hz Std Eff	4488	4105	4527	4144	4593	4182	NA	NA	26039	195	43
	2038	1864	2055	1881	2085	1899			11822	4956	1080
350 Ton 50 Hz High Eff	4173	4152	4053	4032	3927	3905	3808	3787	31836	235	44
	1895	1885	1840	1830	1783	1773	1729	1719	14453	5956	1125



# Installation - Mechanical

**Table 6 Lifting Weights and CG Dimensions (Refer to Figure 14 - Figure 15)**

Unit	W1	W2	W3	W4	W5	W6	W7	W8	Shipping Weight	Xcg	Ycg
	lbs kg	lbs kg	lbs kg	lbs kg	lbs kg	lbs kg	lbs kg	lbs kg	lbs kg	in mm	in mm
350 Ton 50 Hz Std Eff	3778	3757	3675	3654	3566	3545	3465	3444	28882	235	44
	1715	1705	1668	1659	1619	1610	1573	1563	13113	5961	1125
350 Ton 60 Hz High Eff	4036	4017	3912	3893	3782	3763	3660	3641	30703	234	44
	1832	1824	1776	1767	1717	1708	1661	1653	13939	5949	1125
350 Ton 60 Hz Std Eff	4283	3877	4754	4348	5229	4823	NA	NA	27315	204	43
	1944	1760	2158	1974	2374	2190			12401	5179	1080
375 Ton 50 Hz High Eff	4502	4479	4244	4221	3863	3841	3592	3569	32311	261	44
	2044	2034	1927	1916	1754	1744	1631	1620	14669	6632	1125
375 Ton 50 Hz Std Eff	4332	4298	3984	3950	3618	3584	3274	3240	30279	227	44
	1967	1951	1809	1793	1643	1627	1486	1471	13747	5761	1123
400 Ton 50 Hz High Eff	4341	4265	4367	4291	4406	4330	4433	4357	34791	273	44
	1971	1936	1983	1948	2000	1966	2013	1978	15795	6939	1118
400 Ton 50 Hz Std Eff	4195	4173	4075	4053	3950	3928	3832	3810	32014	235	44
	1904	1894	1850	1840	1793	1783	1740	1730	14534	5956	1125
400 Ton 60 Hz High Eff	4341	4265	4367	4291	4406	4330	4433	4357	34790	273	44
	1971	1936	1983	1948	2000	1966	2013	1978	15795	6939	1120
400 Ton 60 Hz Std Eff	4195	4173	4075	4053	3950	3928	3832	3810	32016	234	44
	1905	1895	1850	1840	1793	1783	1740	1730	14535	5954	1125
450 Ton 60 Hz Std Eff	4532	4509	4273	4251	3892	3870	3621	3598	32545	261	44
	2057	2047	1940	1930	1767	1757	1644	1633	14775	6634	1125
500 Ton 60 Hz Std Eff	4359	4283	4385	4309	4424	4348	4451	4375	34935	273	44
	1979	1945	1991	1956	2008	1974	2021	1986	15860	6939	1118
<b>Remote Evaporator Aluminum Fins</b>											
140 Ton 50 Hz High Eff	2033	2292	1972	2244	NA	NA	NA	NA	8542	86	45
	922	1040	895	1018					3875	2179	1138
140 Ton 50 Hz Std Eff	2030	2287	1967	2238	NA	NA	NA	NA	8522	86	45
	921	1038	892	1015					3866	2177	1138
140 Ton 60 Hz High Eff	2030	2288	1967	2238	NA	NA	NA	NA	8522	86	45
	921	1038	892	1015					3866	2177	1138
140 Ton 60 Hz Std Eff	2026	2283	1961	2232	NA	NA	NA	NA	8502	86	45
	919	1036	889	1013					3857	2177	1138
155 Ton 50 Hz High Eff	2725	2944	2119	2337	NA	NA	NA	NA	10125	104	44
	1236	1335	961	1060					4593	2637	1115
155 Ton 50 Hz Std Eff	2139	2305	2087	2265	NA	NA	NA	NA	8795	86	44
	970	1046	947	1027					3989	2177	1113
155 Ton 60 Hz High Eff	2612	2918	1975	2281	NA	NA	NA	NA	9786	103	45
	1185	1323	896	1034					4439	2619	1138
155 Ton 60 Hz Std Eff	2031	2285	1968	2236	NA	NA	NA	NA	8520	86	45
	921	1037	893	1014					3865	2177	1135
170 Ton 50 Hz High Eff	2749	3073	2128	2451	NA	NA	NA	NA	10400	104	45
	1247	1394	965	1112					4717	2637	1138
170 Ton 50 Hz Std Eff	2138	2415	2133	2411	NA	NA	NA	NA	9097	87	45
	970	1096	967	1094					4126	2197	1135
170 Ton 60 Hz High Eff	2626	2938	1990	2302	NA	NA	NA	NA	9856	103	45
	1191	1332	903	1044					4471	2621	1138
170 Ton 60 Hz Std Eff	2033	2291	1971	2243	NA	NA	NA	NA	8538	86	45
	922	1039	894	1018					3873	2179	1138
185 Ton 50 Hz High Eff	3034	3485	2423	2875	NA	NA	NA	NA	11817	122	45
	1376	1581	1099	1304					5360	3106	1153
185 Ton 50 Hz Std Eff	2786	3118	2116	2449	NA	NA	NA	NA	10469	103	45
	1264	1414	960	1111					4749	2621	1138
185 Ton 60 Hz High Eff	2911	3403	2300	2793	NA	NA	NA	NA	11407	122	46
	1320	1544	1043	1267					5174	3101	1166



# Installation - Mechanical

**Table 6 Lifting Weights and CG Dimensions (Refer to Figure 14 - Figure 15)**

Unit	W1	W2	W3	W4	W5	W6	W7	W8	Shipping Weight	Xcg	Ycg
	lbs kg	lbs kg	lbs kg	lbs kg	lbs kg	lbs kg	lbs kg	lbs kg	lbs kg	in mm	in mm
185 Ton 60 Hz Std Eff	2740	2991	2079	2329	NA	NA	NA	NA	10139	103	44
	1243	1357	943	1057					4599	2619	1123
200 Ton 50 Hz High Eff	3156	3531	2478	2853	NA	NA	NA	NA	12019	122	45
	1432	1602	1124	1294					5452	3091	1138
200 Ton 50 Hz Std Eff	2811	3140	2196	2525	NA	NA	NA	NA	10672	104	45
	1275	1424	996	1146					4841	2644	1138
200 Ton 60 Hz High Eff	3097	3466	2413	2782	NA	NA	NA	NA	11759	121	45
	1405	1572	1095	1262					5334	3084	1138
200 Ton 60 Hz Std Eff	2781	3108	2163	2490	NA	NA	NA	NA	10542	104	45
	1262	1410	981	1129					4782	2639	1138
225 Ton 60 Hz Std Eff	3096	3516	2425	2845	NA	NA	NA	NA	11880	122	45
	1404	1595	1100	1290					5389	3091	1148
250 Ton 60 Hz Std Eff	3156	3531	2478	2853	NA	NA	NA	NA	12019	122	45
	1432	1602	1124	1294					5452	3091	1138
<b>Remote Evaporator Copper Fins</b>											
140 Ton 50 Hz High Eff	2506	2883	2697	3031	NA	NA	NA	NA	11116	88	45
	1137	1308	1223	1375					5042	2245	1140
140 Ton 50 Hz Std Eff	2503	2878	2691	3025	NA	NA	NA	NA	11096	88	45
	1135	1305	1221	1372					5033	2245	1140
140 Ton 60 Hz High Eff	2503	2878	2691	3025	NA	NA	NA	NA	11096	88	45
	1135	1306	1221	1372					5033	2245	1140
140 Ton 60 Hz Std Eff	2499	2874	2685	3019	NA	NA	NA	NA	11076	88	45
	1134	1303	1218	1369					5024	2245	1140
155 Ton 50 Hz High Eff	3472	3810	2963	3301	NA	NA	NA	NA	13545	107	44
	1575	1728	1344	1497					6144	2710	1123
155 Ton 50 Hz Std Eff	2612	2896	2811	3051	NA	NA	NA	NA	11369	88	44
	1185	1313	1275	1384					5157	2243	1120
155 Ton 60 Hz High Eff	3359	3783	2819	3244	NA	NA	NA	NA	13206	106	45
	1524	1716	1279	1471					5990	2700	1140
155 Ton 60 Hz Std Eff	2505	2876	2692	3022	NA	NA	NA	NA	11094	88	45
	1136	1305	1221	1371					5032	2245	1138
170 Ton 50 Hz High Eff	3496	3938	2972	3414	NA	NA	NA	NA	13820	107	45
	1586	1786	1348	1549					6269	2708	1140
170 Ton 50 Hz Std Eff	2611	3006	2857	3198	NA	NA	NA	NA	11671	89	45
	1184	1363	1296	1450					5294	2258	1138
170 Ton 60 Hz High Eff	3373	3803	2834	3265	NA	NA	NA	NA	13276	106	45
	1530	1725	1286	1481					6022	2700	1140
170 Ton 60 Hz Std Eff	2506	2882	2695	3030	NA	NA	NA	NA	11112	88	45
	1137	1307	1223	1374					5040	2245	1140
185 Ton 50 Hz High Eff	3969	4570	3471	4072	NA	NA	NA	NA	16082	125	45
	1800	2073	1575	1847					7295	3180	1151
185 Ton 50 Hz Std Eff	3532	3984	2960	3412	NA	NA	NA	NA	13889	106	45
	1602	1807	1343	1548					6300	2697	1140
185 Ton 60 Hz High Eff	3846	4487	3349	3990	NA	NA	NA	NA	15672	125	46
	1745	2035	1519	1810					7109	3178	1161
185 Ton 60 Hz Std Eff	3487	3857	2923	3293	NA	NA	NA	NA	13559	106	45
	1581	1749	1326	1494					6150	2697	1130
200 Ton 50 Hz High Eff	4092	4615	3527	4050	NA	NA	NA	NA	16284	125	45
	1856	2094	1600	1837					7386	3167	1140
200 Ton 50 Hz Std Eff	3557	4006	3040	3489	NA	NA	NA	NA	14092	107	45
	1613	1817	1379	1583					6392	2713	1140
200 Ton 60 Hz High Eff	4033	4551	3462	3979	NA	NA	NA	NA	16024	125	45
	1829	2064	1570	1805					7269	3165	1140

# Installation - Mechanical

**Table 6** Lifting Weights and CG Dimensions (Refer to Figure 14 - Figure 15)

Unit	W1	W2	W3	W4	W5	W6	W7	W8	Shipping Weight	Xcg	Ycg
	lbs kg	lbs kg	lbs kg	lbs kg	lbs kg	lbs kg	lbs kg	lbs kg	lbs kg	in mm	in mm
200 Ton 60 Hz Std Eff	3528	3974	3007	3453	NA	NA	NA	NA	13962	107	45
	1600	1802	1364	1566					6333	2710	1140
225 Ton 60 Hz Std Eff	4031	4600	3473	4042	NA	NA	NA	NA	16145	125	45
	1828	2086	1575	1833					7323	3167	1148
250 Ton 60 Hz Std Eff	4092	4615	3527	4050	NA	NA	NA	NA	16284	125	45
	1856	2094	1600	1837					7386	3167	1140

**Table 7** Remote Evaporator Lifting Weights

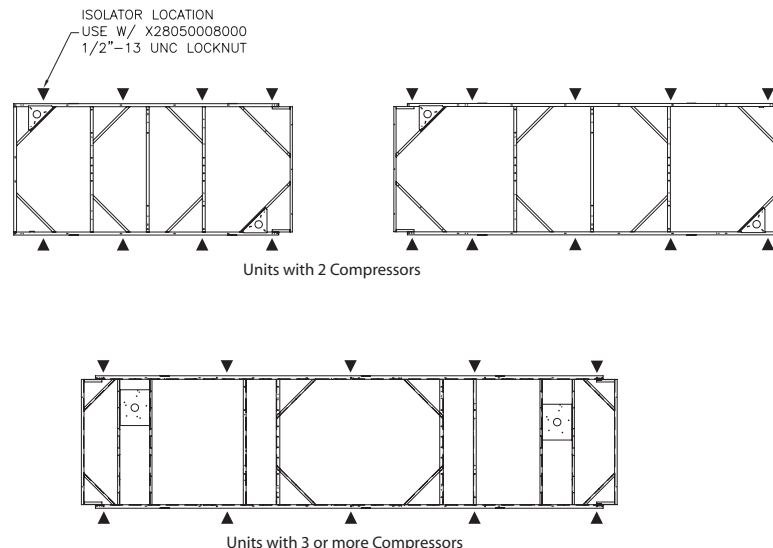
Tonnage	Standard Eff								Premium Eff				
	140	155	170	185	200	225	250	140	155	170	185	200	
lbs	2487	2525	2528	2556	2600	2797	2846	2528	2556	2600	2797	2846	
Kg	1128	1145	1146	1159	1179	1268	1291	1146	1159	1179	1268	1291	

## Isolation and Sound Emission

The most effective form of isolation is to locate the unit away from any sound sensitive area. Structurally transmitted sound can be reduced by elastomeric vibration eliminators. Spring isolators are not recommended. Consult an acoustical engineer in critical sound applications.

For maximum isolation effect, isolate water lines and electrical conduit. Wall sleeves and rubber isolated piping hangers can be used to reduce the sound transmitted through water piping. To reduce the sound transmitted through electrical conduit, use flexible electrical conduit.

State and local codes on sound emissions should always be considered. Since the environment in which a sound source is located affects sound pressure, unit placement must be carefully evaluated. Sound power levels for Trane air-cooled Series R® chillers are available on request.



**Figure 17** Unit Isolator Locations



# Installation - Mechanical

**Table 8 Unit Isolators**

Tonnage	Efficiency	Frequency	Unit Type	Condenser Fin Material	Isolator Part Number	Quantity
140	Std/High	50/60	Packaged	AL	X10140305620	8
140	Std/High	50/60	Remote	AL	X10140305610	8
140	Std/High	50/60	Packaged/Remote	Cu	X10140305620	8
155	Std/High	50/60	Packaged	AL	X10140305620	8
155	Std/High	50/60	Remote	AL	X10140305610	8
155	Std/High	50/60	Packaged/Remote	Cu	X10140305620	8
170	Std/High	50/60	Packaged	AL	X10140305620	8
170	Std/High	50/60	Remote	AL	X10140305610	8
170	Std/High	50/60	Packaged/Remote	Cu	X10140305620	8
185	Std	50/60	Packaged	AL	X10140305620	8
185	High	50/60	Packaged	AL	X10140305620	10
185	Std	50/60	Remote	AL	X10140305610	8
185	High	50/60	Remote	AL	X10140305610	10
185	Std	50/60	Packaged	Cu	X10140305620	8
185	High	50/60	Packaged	Cu	X10140305620	10
185	Std	50/60	Remote	Cu	X10140305620	8
185	High	50/60	Remote	Cu	X10140305620	10
200	Std	50/60	Packaged	AL	X10140305620	8
200	High	50/60	Packaged	AL	X10140305620	10
200	Std	50/60	Remote	AL	X10140305610	8
200	High	50/60	Remote	AL	X10140305610	10
200	Std	50/60	Packaged	Cu	X10140305620	8
200	High	50/60	Packaged	Cu	X10140305620	10
200	Std	50/60	Remote	Cu	X10140305620	8
200	High	50/60	Remote	Cu	X10140305620	10
225	Std	50/60	Packaged	AL	X10140305620	10
225	Std	50/60	Remote	AL	X10140305610	10
225	Std	50/60	Packaged/Remote	Cu	X10140305620	10
225	High	60	Packaged	Al/Cu	X10140305620	10
250	Std	50/60	Packaged	AL	X10140305620	10
250	Std	50/60	Remote	AL	X10140305610	10
250	Std	50/60	Packaged/Remote	Cu	X10140305620	10
250	High	60	Packaged	Al/Cu	X10140305620	10
250	Std	50	Packaged	Al/Cu	X10140305630	10
250	High	50	Packaged	Al/Cu	X10140305640	10
275	Std/High	50/60	Packaged	Al/Cu	X10140305640	10
300	Std/High	50/60	Packaged	Al/Cu	X10140305640	10
350	Std	60	Packaged	Al/Cu	X10140305640	10
350	Std	50	Packaged	Al/Cu	X10140305640	10
350	High	50/60	Packaged	Al/Cu	X10140305640	10
375	Std/High	50	Packaged	Al/Cu	X10140305640	10
400	Std/High	50/60	Packaged	Al/Cu	X10140305640	10
450	Std/High	60	Packaged	Al/Cu	X10140305640	10
500	Std	60	Packaged	Al/Cu	X10140305640	10

## Noise Considerations

Locate the outdoor unit away from sound sensitive areas. If required, install rubber vibration isolators in all water piping and use flexible electrical conduit. Consult an acoustical engineer for critical applications. Also refer to Trane Engineering Bulletins for application information on RTAC chillers.

# Installation - Mechanical

## Foundation

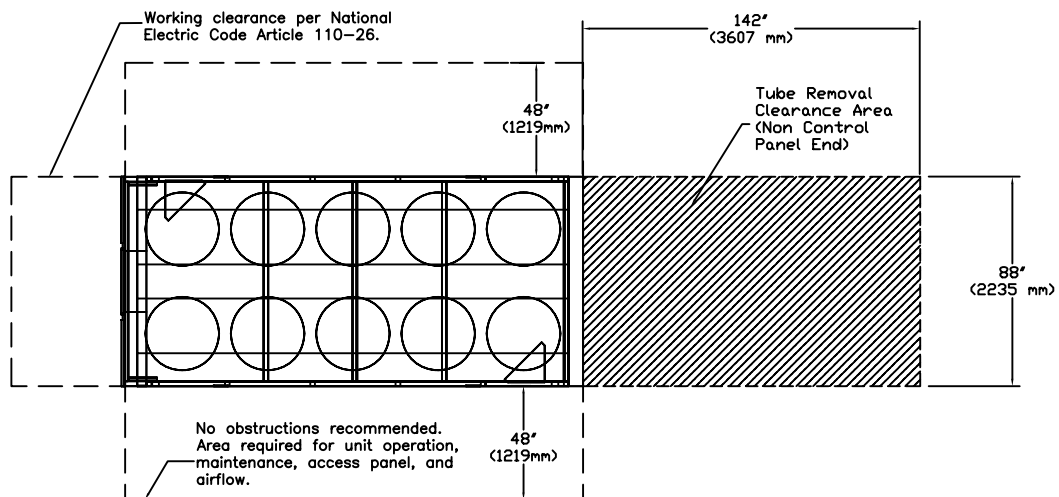
Provide rigid, non-warping mounting pads or a concrete foundation of sufficient strength and mass to support the outdoor unit operating weight (i.e., including completed piping, and full operating charges of refrigerant, oil and water). Refer to [Table 1](#) through [Table 5](#) in the General Information section for unit operating weights. Once in place, the outdoor unit must be level within 1/4" (6 mm) over its length and width.

The Trane Company is not responsible for equipment problems resulting from an improperly designed or constructed foundation.

*NOTE: To allow for cleaning under the condensing coil, it is recommended that an opening be left between the unit base and the concrete pad.*

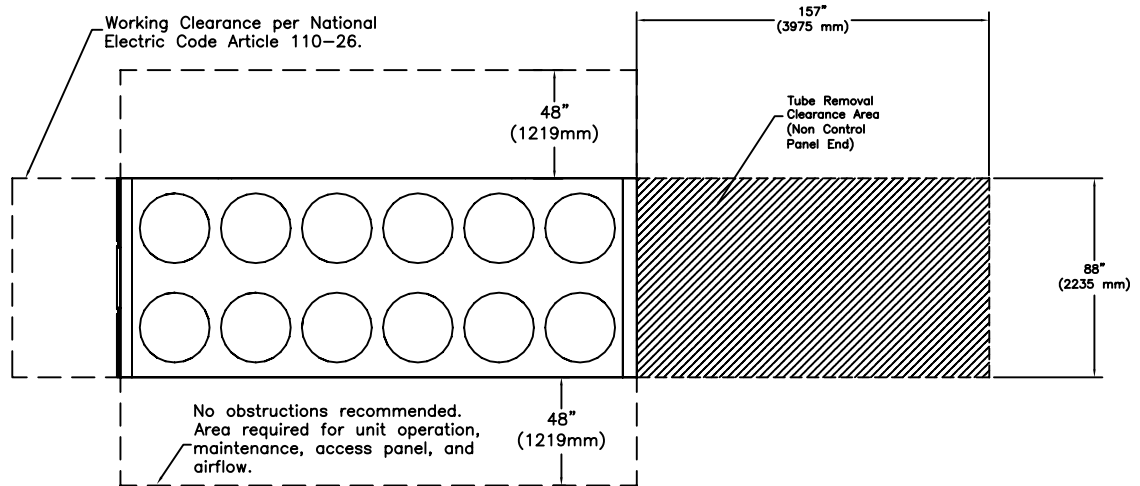
## Clearances

Provide enough space around the outdoor unit to allow the installation and maintenance personnel unrestricted access to all service points. Refer to submittal drawings for the unit dimensions. A minimum of 4 feet (1.2 m) is recommended for compressor service. Provide sufficient clearance for the opening of control panel doors. Refer to [Figure 18](#) through [Figure 19](#) for minimum clearances. In all cases, local codes which require additional clearances will take precedence over these recommendations.

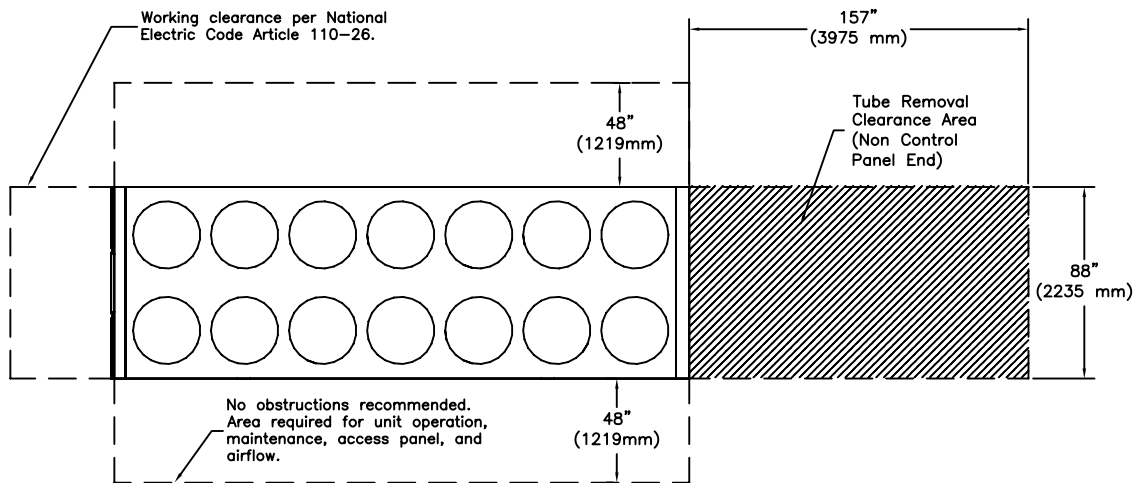


**Figure 18 Recommended Unit Clearances 15-foot bases**

# Installation - Mechanical

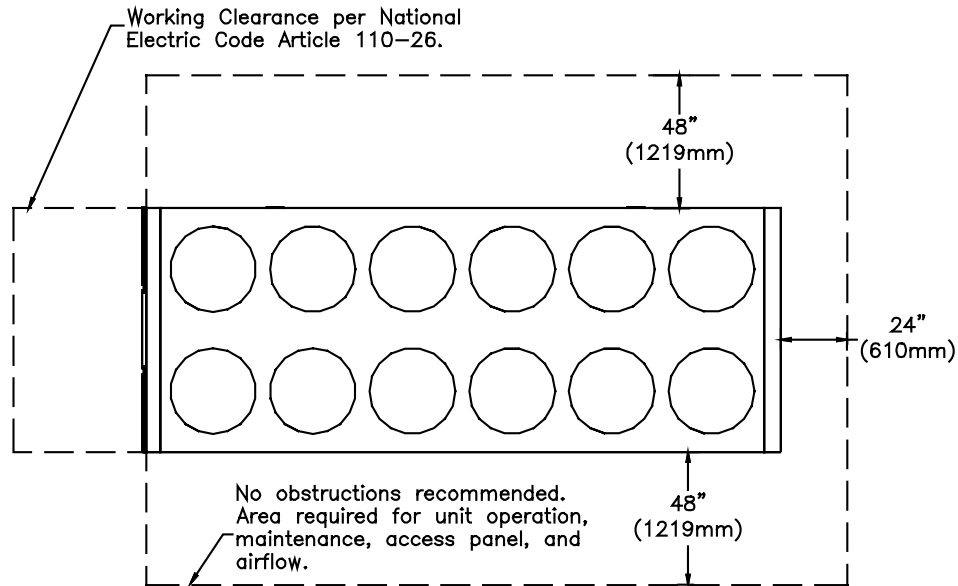


**Figure 19 Recommended Unit Clearances 18-21 foot bases**

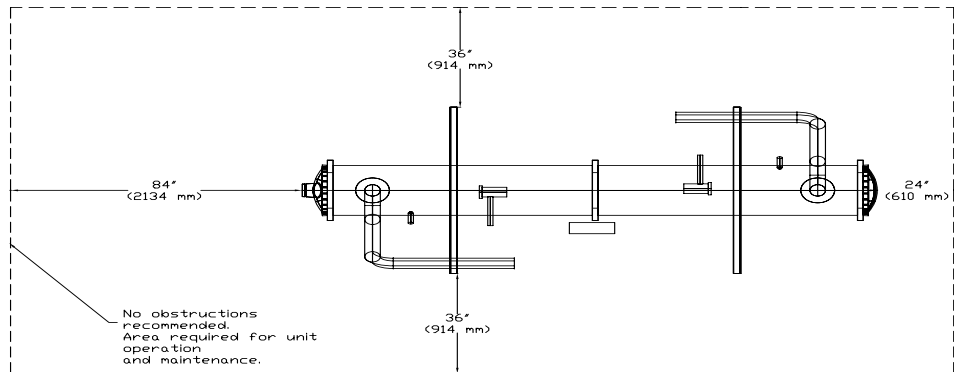


**Figure 20 Recommended Unit Clearances 30-45 foot bases**

## Installation - Mechanical



**Figure 21 Recommended Remote Evaporator Unit Clearances 15-30 foot bases**



**Figure 22 Recommended Evaporator Clearance**

Unobstructed flow of condenser air is essential to maintain chiller capacity and operating efficiency. When determining unit placement, give careful consideration to assuring a sufficient flow of air across the condenser heat transfer surface. Two detrimental conditions are possible and must be avoided if optimum performance is to be achieved: warm air recirculation and coil starvation.

Warm air recirculation occurs when discharge air from the condenser fans is recycled back to the condenser coil inlet. Coil starvation occurs when free airflow to (or from) the condenser is restricted.

Both warm air recirculation and coil starvation cause reduction in unit efficiency and capacity due to the increased head pressures.



## Installation - Mechanical

---

Debris, trash, supplies etc. should not be allowed to accumulate in the vicinity of the unit. Supply air movement may draw debris into the condenser coil, blocking spaces between coil fins and causing coil starvation. Special consideration should be given to low ambient units. Condenser coils and fan discharge must be kept free of snow or other obstructions to permit adequate airflow for satisfactory unit operation.

In situations where equipment must be installed with less clearance than recommended, such as frequently occurs in retrofit and rooftop applications, restricted airflow is common. The Main Processor will direct the unit to make as much chilled water as possible given the actual installed conditions. Consult your Trane sales engineer for more details.

*NOTE: If the outdoor unit configuration requires a variance to the clearance dimensions, contact your Trane Sales Office Representative. Also refer to Trane Engineering Bulletins for application information on RTAC chillers.*

### Unit Isolation and Leveling

For additional reduction of sound and vibration, install the optional neoprene isolators.

Construct an isolated concrete pad for the unit or provide concrete footings at the unit mounting points. Mount the unit directly to the concrete pads or footings.

Level the unit using the base rail as a reference. The unit must be level within 1/4-in (6 mm) over the entire length and width. Use shims as necessary to level the unit.

### Neoprene Isolator Installation

1. Secure the isolators to the mounting surface using the mounting slots in the isolator base plate. Do not fully tighten the isolator mounting bolts at this time.
2. Align the mounting holes in the base of the unit with the threaded positioning pins on the top of the isolators.
3. Lower the unit onto the isolators and secure the isolator to the unit with a nut. Maximum isolator deflection should be 1/4 inch (6 mm).
4. Level the unit carefully. Fully tighten the isolator mounting bolts.

### Drainage

Provide a large capacity drain for water vessel drain-down during shutdown or repair. The evaporator is provided with a drain connection. All local and national codes apply. The vent on the top of the evaporator waterbox is provided to prevent a vacuum by allowing air into the evaporator for complete drainage.

### Evaporator Water Piping

Thoroughly flush all water piping to the unit before making the final piping connections to the unit.

### Evaporator Piping

Components and layout will vary slightly, depending on the location of connections and the water source.

## CAUTION Evaporator Damage!

**The chilled water connections to the evaporator are to be “victaulic” type connections. Do not attempt to weld these connections, as the heat generated from welding can cause microscopic and macroscopic fractures on the cast iron waterboxes that can lead to premature failure of the waterbox. To prevent damage to chilled water components, do not allow evaporator pressure (maximum working pressure) to exceed 150 psig (10.5 bar).**



## Installation - Mechanical

---

Provide shutoff valves in lines to the gauges to isolate them from the system when they are not in use. Use rubber vibration eliminators to prevent vibration transmission through the water lines. If desired, install thermometers in the lines to monitor entering and leaving water temperatures. Install a balancing valve in the leaving water line to control water flow balance. Install shutoff valves on both the entering and leaving water lines so that the evaporator can be isolated for service.

### CAUTION Use Piping Strainers!

**To prevent evaporator damage, pipe strainers must be installed in the water supplies to protect components from water born debris. Trane is not responsible for equipment-only-damage caused by water born debris.**

“Piping components” include all devices and controls used to provide proper water system operation and unit operating safety. These components and their general locations are given below.

#### Entering Chilled Water Piping

- Air vents (to bleed air from system).
- Water pressure gauges with shutoff valves.
- Vibration eliminators.
- Shutoff (isolation) valves. Thermometers (if desired).
- Clean-out tees.
- Pipe strainer.

#### Leaving Chilled Water Piping

- Air vents (to bleed air from system).
- Water pressure gauges with shutoff valves. Vibration eliminators.
- Shutoff (isolation) valves.
- Thermometers.
- Clean-out tees.
- Balancing valve.
- Flow Switch

#### Evaporator Drain

A 1/2 inch drain connection is located under the outlet end of the evaporator waterbox. This may be connected to a suitable drain to permit evaporator drainage during unit servicing. A shutoff valve must be installed on the drain line.

#### Evaporator Flow Switch

Specific connection and schematic wiring diagrams are shipped with the unit. Some piping and control schemes, particularly those using a single water pump for both chilled and hot water, must be analyzed to determine how and or if a flow sensing device will provide desired operation.

Follow the manufacturer’s recommendations for selection and installation procedures. General guidelines for flow switch installation are outlined below

1. Mount the switch upright, with a minimum of 5 pipe diameters of straight horizontal run on each side. Do not install close to elbows, orifices or valves.

*NOTE: The arrow on the switch must point in the direction of flow.*

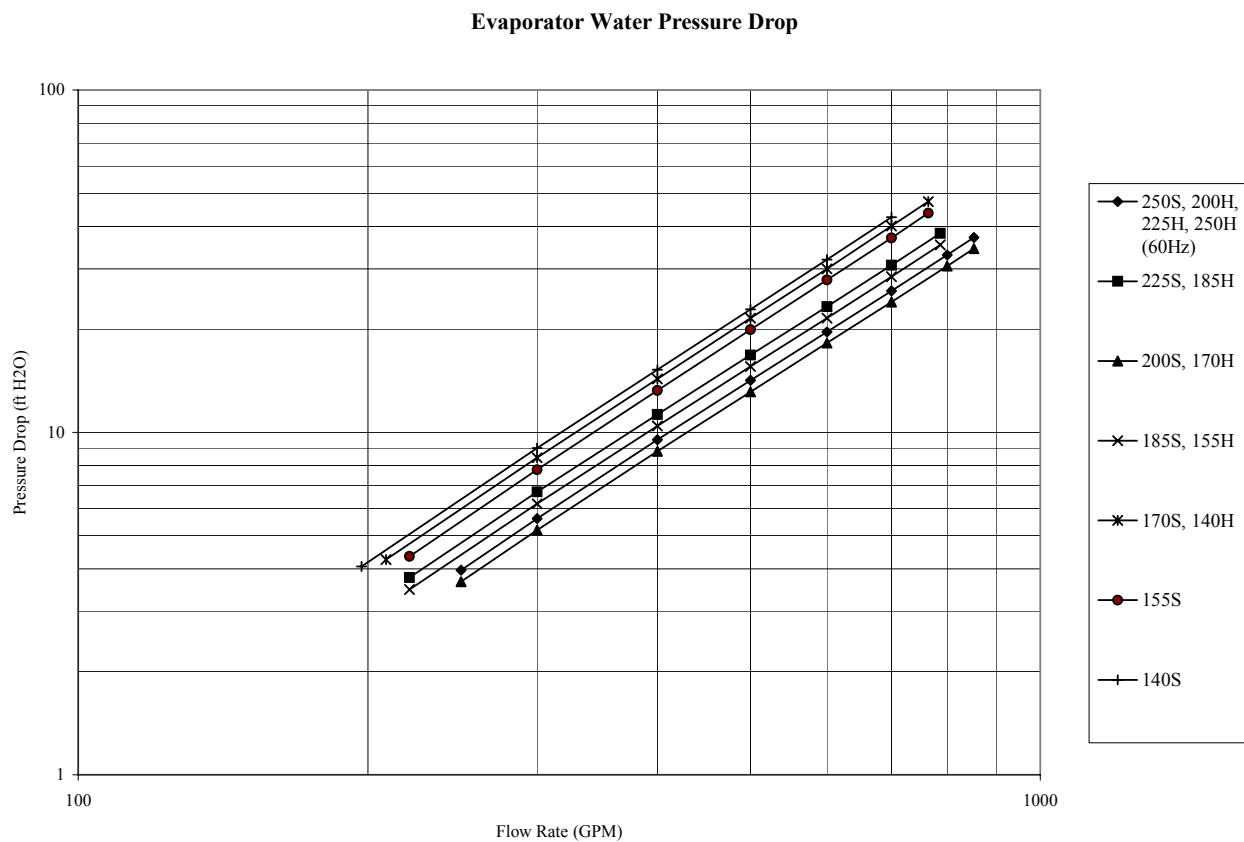
## Installation - Mechanical

- To prevent switch fluttering, remove all air from the water system.

*NOTE: The CH530 provides a 6-second time delay after a "loss-of-flow" diagnostic before shutting the unit down. Contact a qualified service representative if nuisance machine shutdowns persist.*

- Adjust the switch to open when water flow falls below the minimum flow rate.  
Evaporator data is given in the General Information section. Flow switch contacts are closed on proof of water flow.
- Install a pipe strainer in the entering evaporator water line to protect components from waterborne debris.

### Evaporator Water Pressure Drop RTAC 140 - 250 Ton



**Figure 23** Evaporator Water Pressure Drop



# Installation - Mechanical

## Evaporator Water Pressure Drop RTAC 250 - 500 Ton

Water-Side Pressure Drop vs Flow Rate

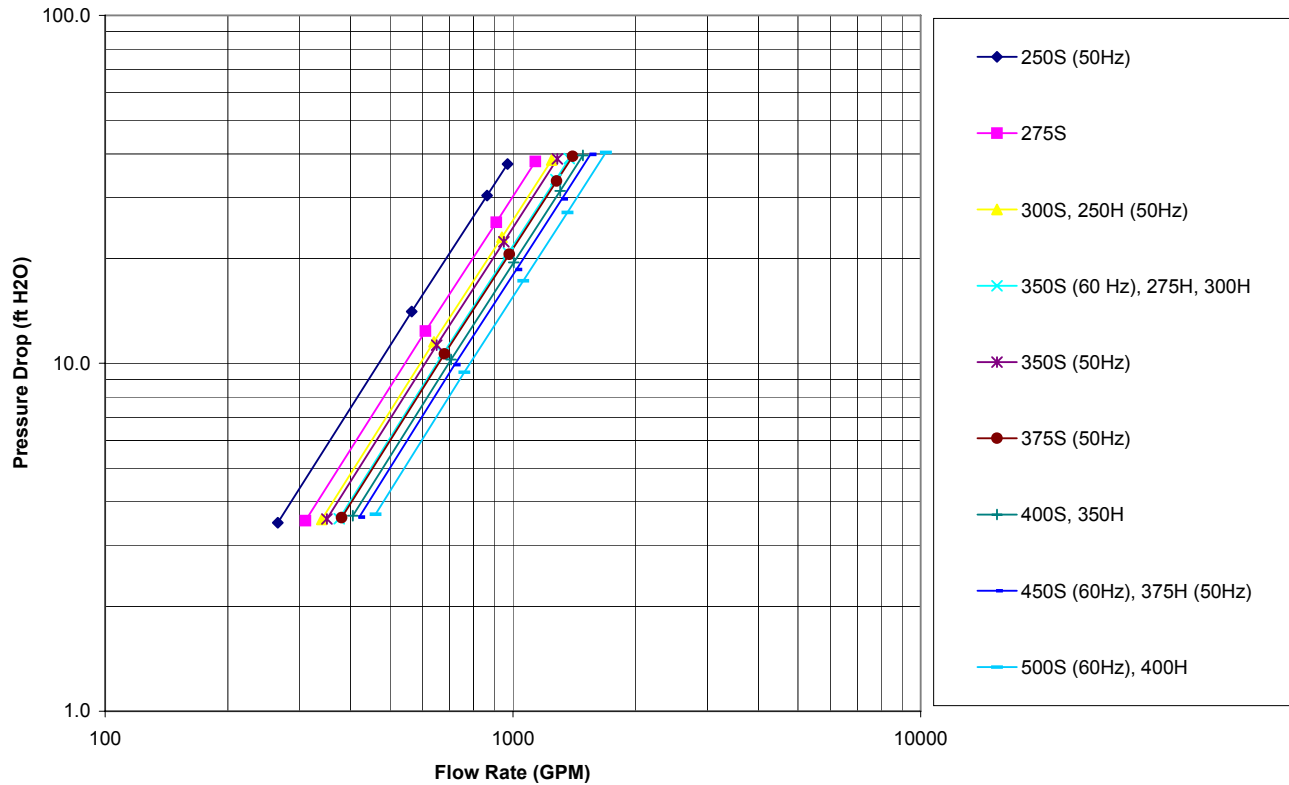


Figure 24 Evaporator Water Pressure Drop

### CAUTION Proper Water Treatment!

The use of untreated or improperly treated water in a unit may result in scaling, erosion, corrosion, algae or slime. It is recommended that the services of a qualified water treatment specialist be engaged to determine what water treatment, if any, is required. Trane assumes no responsibility for equipment failures which result from untreated or improperly treated water, or saline or brackish water.

If using an acidic commercial flushing solution, construct a temporary bypass around the unit to prevent damage to internal components of the evaporator.

Dirt, scale, products of corrosion and other foreign material will adversely affect heat transfer between the water and system components. Foreign matter in the chilled water system can also increase pressure drop and, consequently, reduce water flow. Proper water treatment must be determined locally, depending on the type of system and local water characteristics.

## Installation - Mechanical

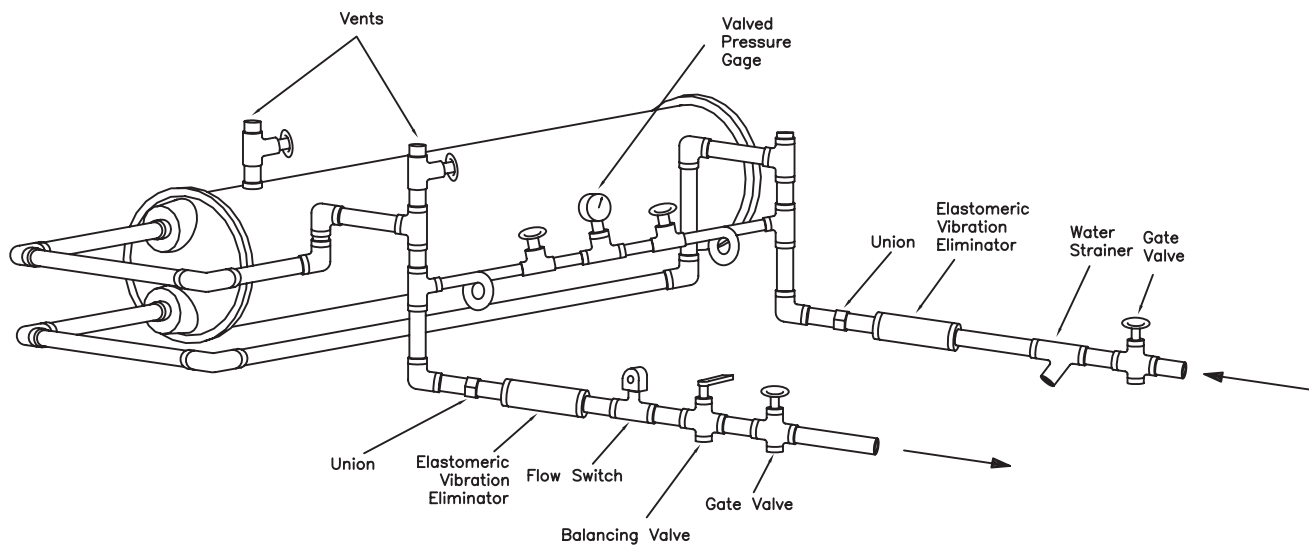
Neither salt nor brackish water is recommended for use in Trane air-cooled Series R<sup>®</sup> chillers. Use of either will lead to a shortened life to an indeterminable degree. The Trane Company encourages the employment of a reputable water treatment specialist, familiar with local water conditions, to assist in this determination and in the establishment of a proper water treatment program.

Using untreated or improperly treated water in these units may result in inefficient operation and possible tube damage. Consult a qualified water treatment specialist to determine whether treatment is needed. The following disclamatory label is provided on each RTAC unit:

*NOTE: The use of improperly treated or untreated water in this equipment may result in scaling, erosion, corrosion, algae or slime. The services of a qualified water treatment specialist should be engaged to determine what treatment, if any, is advisable. The Trane Company warranty specifically excludes liability for corrosion, erosion or deterioration of Trane equipment.*

### Water Pressure Gauges

Install field-supplied pressure components as shown in [Figure 25](#). Locate pressure gauges or taps in a straight run of pipe; avoid placement near elbows, etc. Be sure to install the gauges at the same elevation on each shell if the shells have opposite-end water connections.



**Figure 25 Suggested Piping for Typical RTAC Evaporator**

*NOTE: Once the unit is installed at a site, one vertical or one diagonal unit support can be permanently removed if it creates an obstruction for water piping.*

To read manifolded pressure gauges, open one valve and close the other (depending upon the reading desired). This eliminates errors resulting from differently calibrated gauges installed at unmatched elevations.



# Installation - Mechanical

---

## Water Pressure Relief Valves

### CAUTION Shell Damage!

**To prevent shell damage, install pressure relief valves in the evaporator water system.**

Install a water pressure relief valve in the evaporator inlet piping between the evaporator and the inlet shutoff valve, as shown in [Figure 25](#). Water vessels with close-coupled shutoff valves have a high potential for hydrostatic pressure buildup on a water temperature increase. Refer to applicable codes for relief valve installation guidelines.

### Freeze Protection

If the unit will remain operational at subfreezing ambient temperatures, the chilled water system must be protected from freezing. Heaters are factory-installed on the packaged unit evaporator and will help protect it from freezing in ambient temperatures down to -20°F (-29°C).

Install heat tape on all water piping, pumps, water box nozzles and other components that may be damaged if exposed to freezing temperatures. Heat tape must be designed for low ambient temperature applications. Heat tape selection should be based on the lowest expected ambient temperature.

Add a non-freezing, low temperature, corrosion inhibiting, heat transfer fluid may also be added to the chilled water system. The solution must be strong enough to provide protection against ice formation at the lowest anticipated ambient temperature. Refer to [Table 1](#) through [Table 5](#) in the General Information section for evaporator water storage capacities.

*NOTE: Use of glycol type antifreeze reduces the cooling capacity of the unit and must be considered in the design of the system specifications.*

### CAUTION Evaporator Damage!

**ALL unit chilled water pumps must be controlled by the Trane CH530 to avoid catastrophic damage to the evaporator due to freezing. Refer to RLC-PRB012-EN.**

### Low Evaporator Refrigerant Cutout and % Glycol Recommendations

1. Solution freeze point is 4 deg F below operating point saturation temperature.
2. LRTC is 4 deg F below freeze point.

#### Procedure

1. Is operating condition contained within [Table 9](#)? If no see "Special" below.
2. For leaving fluid temperatures greater than 40 deg F, use settings for 40 deg F.
3. Select operating conditions from [Table 9](#).
4. Read off recommended % glycol.
5. Go to [Table 10](#). From the % glycol.

## Installation - Mechanical

---

### Important

1. Additional glycol beyond the recommendations will adversely effect unit performance. The unit efficiency will be reduced and the saturated evaporator temperature will be reduced. For some operating conditions this effect can be significant.
2. If additional glycol is used, then use the actual % glycol to establish the low refrigerant cutout setpoint.
3. The minimum low refrigerant cutout setpoint allowed is -5 deg F. The minimum is established by the solubility limits of the oil in the refrigerant.

### Specials

The following constitute a special that must be calculated by engineering:

1. Freeze inhibitor other than Ethylene Glycol or Propylene Glycol.
2. Fluid delta T outside the range 4 to 16 deg F.
3. Unit configuration other than Standard, Standard with extra pass, and Premium.
4. % Glycol greater than maximum in column in [Table 10](#).

Special should all be calculated by engineering. The purpose of calculating is to make sure that design saturation temperature is greater than 3 deg F. Additionally, the calculation must verify that the fluid freeze point is a minimum of 4 deg. F lower that the design saturation temperature. The low evaporator temperature cutout will be 4 deg F below the freeze point or -5 deg F, whichever is greater.



# Installation - Mechanical

**Table 9 Glycol Recommendations**

	Ethylene Glycol							Propylene Glycol							
	DT	4	6	8	10	12	14	16	4	6	8	10	12	14	16
	[F]														
	[C]	-15	-14	-13	-12	-11	-10	-9	-15	-14	-13	-12	-11	-10	-9
Leaving Water Temperature (F/C)	38	-	5	5	5	5	6	-	-	6	6	7	7	8	-
	34	-	11	11	11	12	-	-	-	13	13	15	17	-	-
	30	-	15	16	17	18	-	-	-	19	21	-	-	-	-
	28	-	18	18	19	-	-	-	-	22	-	-	-	-	-
	26	-	20	21	22	-	-	-	-	25	-	-	-	-	-
	24	-	22	23	26	-	-	-	-	-	-	-	-	-	-
	22	-	24	26	-	-	-	-	-	-	-	-	-	-	-
	20	-	26	30	-	-	-	-	-	-	-	-	-	-	-
	18	-	29	-	-	-	-	-	-	-	-	-	-	-	-
	16	-	31	-	-	-	-	-	-	-	-	-	-	-	-
	14	30	-	-	-	-	-	-	-	-	-	-	-	-	-
	12	32	-	-	-	-	-	-	-	-	-	-	-	-	-
	10.4	34	-	-	-	-	-	-	-	-	-	-	-	-	-
	-12														

These tables represent the MINIMUM RECOMMENDED glycol percentages for each operating condition

Operation is not recommended at certain operating conditions as some chillers may not satisfy maximum or minimum velocity requirements or minimum performance requirements. Contact Trane Sales Representative for more information regarding the operating limits of a particular chiller.

**Table 10 Recommended Low Evaporator Refrigerant Cutout and % Glycol**

% Glycol	Ethylene Glycol				Propylene Glycol			
	Low Refrig. Temp Cutout		Solution Freeze Point		Low Refrig. Temp Cutout		Solution Freeze Point	
	°F	°C	°F	°C	°F	°C	°F	°C
0	28.0	-2.2	32	0	28.0	-2.2	32.0	0
5	25.0	-3.9	29	-1.7	25.3	-3.7	29.3	-1.5
10	21.5	-5.8	25.5	-3.6	22.4	-5.3	26.4	-3.1
15	17.5	-8.1	21.5	-5.8	19.1	-7.2	23.1	-4.9
20	12.8	-10.7	16.8	-8.4	15.3	-9.3	19.3	-7.1
25	7.4	-13.7	11.4	-11.4	10.8	-11.8	14.8	-9.6
30	1.1	-17.2	5.1	-15.0	5.3	-14.8	9.3	-12.6
35	-5.0	-20.6	-2.3	-19.1	-1.3	-19.5	2.7	-16.3
40	-5.0	-20.6	-10.8	-23.8	-5.0	-20.6	-5.2	-20.7
45	-5.0	-20.6	-20.7	-29.3	-5.0	-20.6	-14.6	-25.9
50	-5.0	-20.6	-32.1	-35.6	-5.0	-20.6	-25.8	-32.1
54	-5.0	-20.6	-42.3	-41.3	-5.0	-20.6	-36.1	-37.8

Chilled Water Temperature Cutout should be set to 5°F below the lowest allowable Chilled Water Set Point bases on the %Glycol.

## Installation - Mechanical

### Remote Evaporator Option

---

The **RTAC 140-250 ton** outdoor unit with the Remote Evaporator option is shipped as two pieces: the outdoor unit (condensing) and the evaporator. Short suction line connections are provided with the outdoor condensing unit. The remote evaporator is shipped complete, with factory-mounted electronic expansion valves, water temperature sensors, suction pressure transducers, liquid level control sensors, all factory wired to a ribbon cable. Solenoid valves and drain valves are wired to a relay board in the terminal box. The installing contractor is required to provide and install the following:

- 2-wire, twisted shielded communication line between the remote evaporator terminal box and the Condensing Unit's control panel
- 115 VAC single phase power supply to the remote evaporator terminal box
- 2 liquid lines
- 2 suction lines
- Suction accumulator as specified

*NOTE: A unit ordered as a remote evaporator must also be ordered with either the wide or low ambient option. The fan inverters are necessary for proper control.*

### System Configuration and Interconnecting Refrigerant Piping

The system may be configured in any of the four arrangements shown in [Figure 26](#). The configurations and their associated elevations, along with the total distance between the remote evaporator and the compressor/condenser section, play a critical role in determining suction and liquid line sizes. This will also affect field refrigerant and oil charges. Consequently, there are physical limits which must not be violated if the system is to operate as designed. Please note the following requirements for field installation:

1. The remote evaporator **MUST** be matched with its respective outdoor condensing unit.
2. The circuit number on the outdoor condensing unit must match the circuit number on the evaporator, i.e. circuit #1 on the outdoor condensing unit must be connected with circuit # 1 on the remote evaporator and likewise for circuit #2. RTAC Circuit Capacities are shown in General Data Tables.

### CAUTION

#### Equipment Damage!

**If the circuits are crossed, serious equipment damage may occur.**

3. Piping between the evaporator and outdoor unit can not exceed 200 actual feet and/or an equivalent length of 300 feet.

*NOTE: The latter includes the equivalent length of all associated field installed fittings, valves, accessories and straight lengths of interconnecting piping.*

4. Horizontal portions of suction lines must be downward sloping toward the compressor at least 1/2 inch for each 10 feet run. This promotes the movement of oil in the direction of gas flow.
5. Suction lines must be insulated.
6. The line sizes defined are to be used only for 40-60 F leaving water temperature and/or full load ice-making applications.



## Installation - Mechanical

### Remote Evaporator Option

---

7. [Figure 26](#), drawing 1 depicts an installation where the remote evaporator elevation is the same as that of the outdoor condensing unit. The suction and liquid lines are horizontal or down flowing only.  

The suction and liquid lines can be put under ground or in a trench. The temperature of the suction lines must never exceed the temperature of the compressor. The line can be below the compressors a maximum of 15 ft.
8. [Figure 26](#), drawing 2 shows a variation to drawing 1. The remote evaporator and outdoor condensing unit are at the same elevation but interconnecting piping may be installed up to 15 feet above the base elevation. Refer to [Table 13](#) to determine the required length of the suction accumulator line. A full size suction accumulator is required at the evaporator and 50% of the value is required at the condensing unit.
9. A refrigerant drain valve is installed at the bottom of the evaporator for freeze protection. This drain valve is a normally open, pilot operated valve which remains closed unless there is a **potential freezing situation detected via low evap temperatures or low water temperatures or a power failure**. If the drain valve is opened the installed suction accumulator must be capable of holding the entire evaporator charge. Refer to [Table 13](#) for sizing.
10. For installations where the remote evaporator is at a lower elevation than the outdoor condensing unit as shown in [Figure 26](#), drawing 3, the elevation difference is not to exceed 100 feet. An inverted liquid line trap at the condensing unit is required to prevent unwanted free cooling. The apex of the liquid line trap should be at a height above the condenser coils. A suction accumulator must be installed at the evaporator. Refer to [Table 13](#) for sizing.
11. When the elevation of the remote evaporator exceeds that of the outdoor condensing unit as shown in [Figure 26](#), drawing 4, the elevation difference is determined by [Table 11](#). The suction accumulator line must be installed according to [Table 13](#). It is very important, for proper control and operation of the chiller, that the elevation requirements given in [Table 11](#) are **not** exceeded. It should also be noted that in this configuration the suction accumulator is installed at the condensing section.  

Note: The height is limited by the available subcooling.
12. Compressor & oil separator heaters must be on at least 24 hours prior to compressor start.

# Installation - Mechanical

## Remote Evaporator Option

Figure 1: Remote Evaporator Installation  
No Elevation Difference  
Suction and Liquid Lines Routed no Higher than Top of Suction Connection Entering the Compressor.

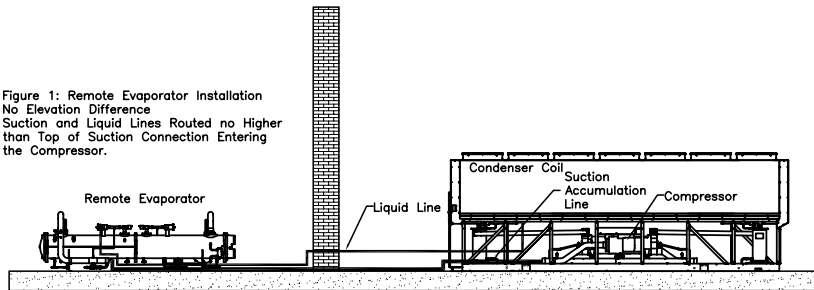


Figure 2: Remote Evaporator Installation  
No Elevation Difference  
Suction and Liquid Lines 15 Feet or Less.

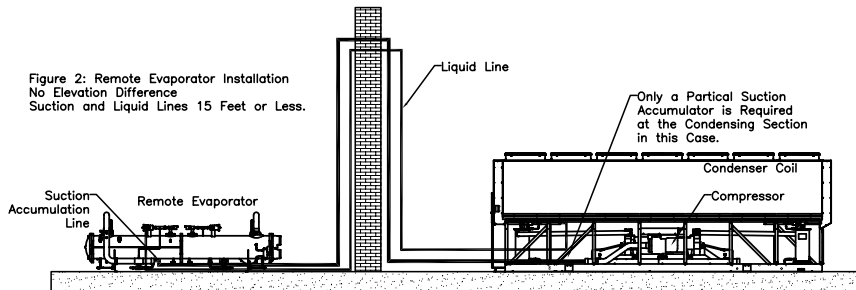


Figure 3: Remote Evaporator Installation  
Condenser Unit Above Evaporator.

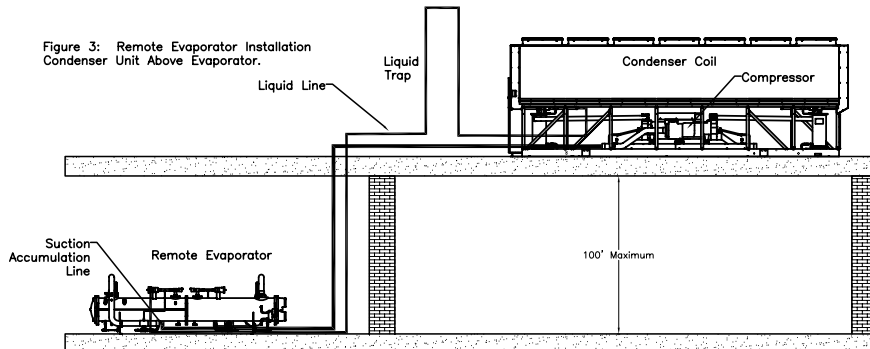


Figure 4: Remote Evaporator Installation  
Condenser Unit Below Evaporator

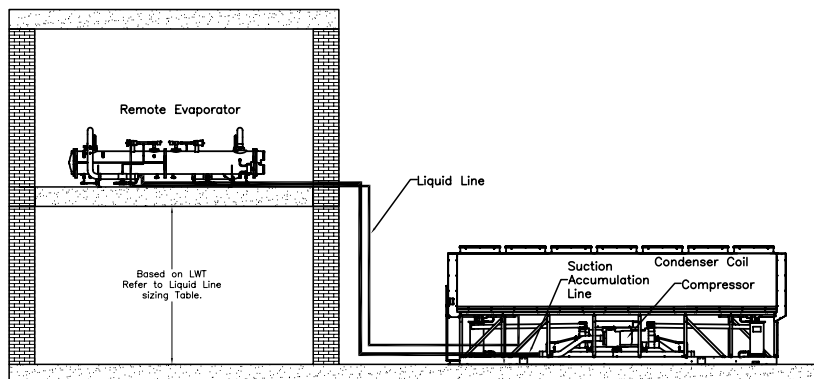


Figure 26 Remote Evaporator Installations



# Installation - Mechanical Remote Evaporator Option

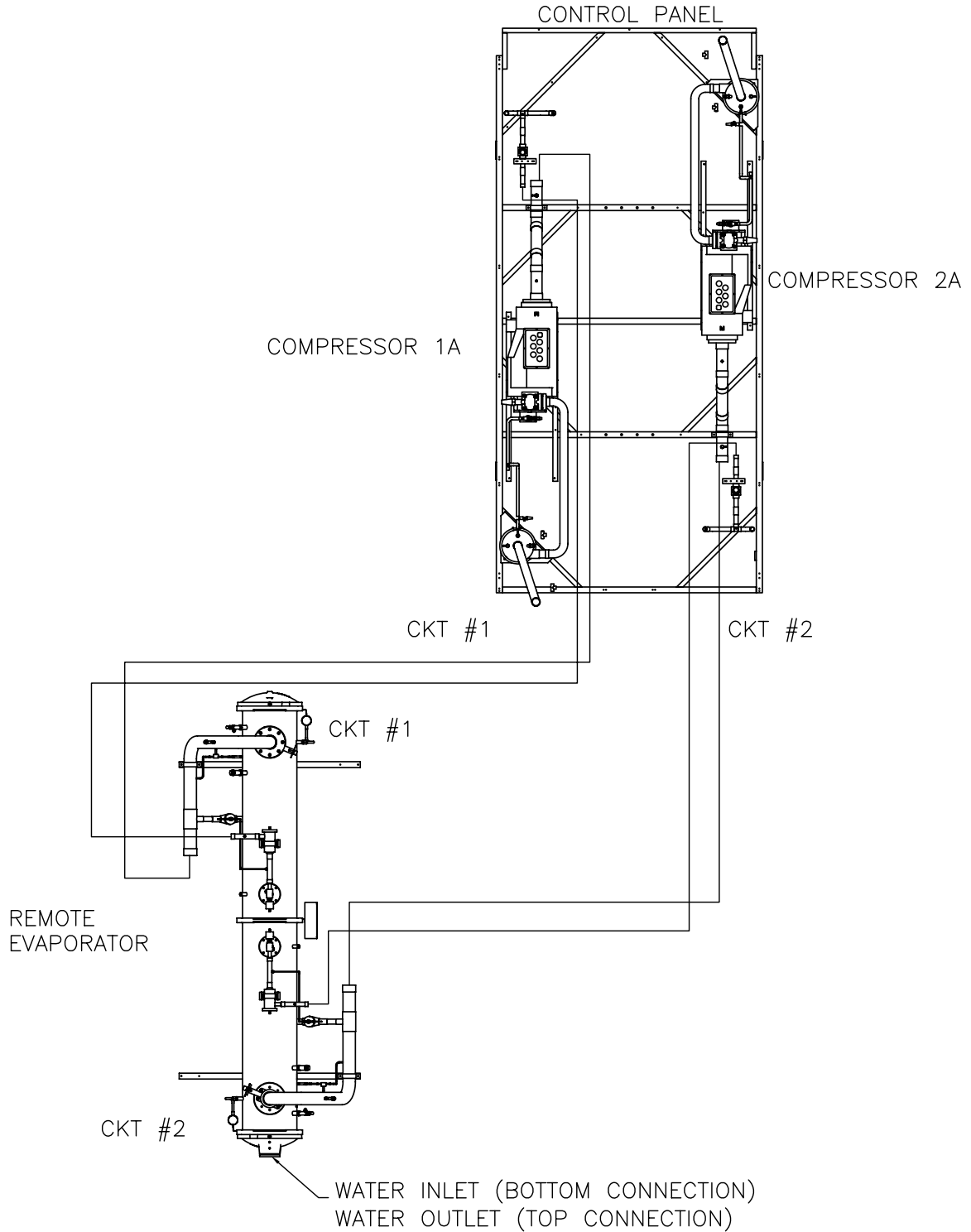


Figure 27 Circuit Identification



# Installation - Mechanical Remote Evaporator Option

## RTAC 140-250 Ton Remote Evaporator Liquid Line Sizes

70-ton Circuit																	
40-50F				Height (ft)					50-60F								
Lvg. Water	0	1 to 5	6 to 10	11 to 15	16 to 20	21 to 25	26 to 30	31 to 35	Lvg. Water	0	1 to 5	6 to 10	11 to 15	16 to 20	21 to 25	26 to 30	
Total Equiv. Length (ft)	25	1.375	1.375	1.375	1.375	1.375	1.375	N/A	25	1.375	1.375	1.375	1.375	1.375	1.375	2.125	
	50	1.375	1.375	1.375	1.375	1.375	1.375	N/A	50	1.375	1.375	1.375	1.375	1.375	1.625	2.125	
	75	1.375	1.375	1.375	1.375	1.375	1.375	1.625	N/A	75	1.375	1.375	1.375	1.375	1.375	1.625	N/A
	100	1.375	1.375	1.375	1.375	1.375	1.375	1.625	N/A	100	1.375	1.375	1.375	1.375	1.625	2.125	N/A
	125	1.375	1.375	1.375	1.375	1.375	1.625	1.625	N/A	125	1.375	1.375	1.375	1.625	1.625	2.125	N/A
	150	1.375	1.375	1.375	1.375	1.375	1.625	N/A	N/A	150	1.375	1.375	1.375	1.625	1.625	2.125	N/A
	175	1.375	1.375	1.375	1.375	1.625	1.625	N/A	N/A	175	1.375	1.375	1.625	1.625	1.625	2.125	N/A
	200	1.375	1.375	1.375	1.375	1.625	1.625	N/A	N/A	200	1.375	1.625	1.625	1.625	2.125	2.125	N/A
	225	1.375	1.375	1.375	1.625	1.625	1.625	N/A	N/A	225	1.375	1.625	1.625	1.625	2.125	2.125	N/A
	250	1.375	1.375	1.375	1.625	1.625	N/A	N/A	N/A	250	1.625	1.625	1.625	1.625	2.125	2.125	N/A
	275	1.375	1.375	1.625	1.625	1.625	N/A	N/A	N/A	275	1.625	1.625	1.625	2.125	2.125	2.125	N/A
300	1.375	1.375	1.625	1.625	1.625	N/A	N/A	N/A	300	1.625	1.625	1.625	2.125	2.125	2.125	N/A	

85-ton Circuit																
40-50F				Height (ft)					50-60F							
Lvg. Water	0	1 to 5	6 to 10	11 to 15	16 to 20	21 to 25	26 to 30	31 to 35	Lvg. Water	0	1 to 5	6 to 10	11 to 15	16 to 20	21 to 25	26 to 30
Total Equiv. Length (ft)	25	1.375	1.375	1.375	1.375	1.375	2.125	N/A	25	1.375	1.375	1.375	1.375	2.125	N/A	N/A
	50	1.375	1.375	1.375	1.375	1.375	1.625	N/A	50	1.375	1.375	1.375	1.625	2.125	N/A	N/A
	75	1.375	1.375	1.375	1.375	1.375	1.625	N/A	75	1.375	1.375	1.625	1.625	N/A	N/A	N/A
	100	1.375	1.375	1.375	1.375	1.625	1.625	N/A	100	1.375	1.625	1.625	2.125	N/A	N/A	N/A
	125	1.375	1.375	1.375	1.625	1.625	2.125	N/A	125	1.375	1.625	1.625	2.125	N/A	N/A	N/A
	150	1.375	1.375	1.375	1.625	1.625	2.125	N/A	150	1.625	1.625	1.625	2.125	N/A	N/A	N/A
	175	1.375	1.375	1.625	1.625	1.625	2.125	N/A	175	1.625	1.625	2.125	2.125	N/A	N/A	N/A
	200	1.375	1.625	1.625	1.625	2.125	2.125	N/A	200	1.625	1.625	2.125	2.125	N/A	N/A	N/A
	225	1.375	1.625	1.625	1.625	2.125	2.125	N/A	225	1.625	2.125	2.125	2.125	N/A	N/A	N/A
	250	1.625	1.625	1.625	1.625	2.125	2.125	N/A	250	1.625	2.125	2.125	2.125	N/A	N/A	N/A
	275	1.625	1.625	1.625	1.625	2.125	2.125	N/A	275	1.625	2.125	2.125	2.125	N/A	N/A	N/A
300	1.625	1.625	1.625	2.125	2.125	2.125	N/A	300	2.125	2.125	2.125	2.125	N/A	N/A	N/A	

100-ton Circuit																
40-50F				Height (ft)					50-60F							
Lvg. Water	0	1 to 5	6 to 10	11 to 15	16 to 20	21 to 25	26 to 30	31 to 35	Lvg. Water	0	1 to 5	6 to 10	11 to 15	16 to 20	21 to 25	26 to 30
Total Equiv. Length (ft)	25	1.625	1.625	1.625	1.625	1.625	1.625	1.625	25	1.625	1.625	1.625	1.625	1.625	1.625	1.625
	50	1.625	1.625	1.625	1.625	1.625	1.625	1.625	50	1.625	1.625	1.625	1.625	1.625	1.625	1.625
	75	1.625	1.625	1.625	1.625	1.625	1.625	1.625	75	1.625	1.625	1.625	1.625	1.625	1.625	2.125
	100	1.625	1.625	1.625	1.625	1.625	1.625	2.125	100	1.625	1.625	1.625	1.625	1.625	1.625	2.125
	125	1.625	1.625	1.625	1.625	1.625	1.625	2.125	125	1.625	1.625	1.625	1.625	1.625	2.125	2.125
	150	1.625	1.625	1.625	1.625	1.625	1.625	2.125	150	1.625	1.625	1.625	1.625	1.625	2.125	2.125
	175	1.625	1.625	1.625	1.625	1.625	1.625	2.125	175	1.625	1.625	1.625	1.625	2.125	2.125	2.125
	200	1.625	1.625	1.625	1.625	1.625	2.125	2.125	200	1.625	1.625	1.625	2.125	2.125	2.125	2.125
	225	1.625	1.625	1.625	1.625	1.625	2.125	2.125	225	1.625	1.625	1.625	2.125	2.125	2.125	2.125
	250	1.625	1.625	1.625	1.625	1.625	2.125	2.125	250	1.625	1.625	2.125	2.125	2.125	2.125	2.625
	275	1.625	1.625	1.625	1.625	2.125	2.125	2.125	275	1.625	1.625	2.125	2.125	2.125	2.125	2.625
300	1.625	1.625	1.625	1.625	2.125	2.125	2.125	300	1.625	2.125	2.125	2.125	2.125	2.125	2.625	

120-ton Circuit																
40-50F				Height (ft)					50-60F							
Lvg. Water	0	1 to 5	6 to 10	11 to 15	16 to 20	21 to 25	26 to 30	31 to 35	Lvg. Water	0	1 to 5	6 to 10	11 to 15	16 to 20	21 to 25	26 to 30
Total Equiv. Length (ft)	25	1.625	1.625	1.625	1.625	1.625	1.625	2.125	25	1.625	1.625	1.625	1.625	1.625	2.125	N/A
	50	1.625	1.625	1.625	1.625	1.625	1.625	2.125	50	1.625	1.625	1.625	1.625	1.625	2.125	N/A
	75	1.625	1.625	1.625	1.625	1.625	1.625	2.625	75	1.625	1.625	1.625	1.625	2.125	2.625	N/A
	100	1.625	1.625	1.625	1.625	1.625	1.625	2.625	100	1.625	1.625	1.625	2.125	2.125	2.625	N/A
	125	1.625	1.625	1.625	1.625	1.625	2.125	2.625	125	1.625	1.625	1.625	2.125	2.125	2.625	N/A
	150	1.625	1.625	1.625	1.625	1.625	2.125	2.625	150	1.625	1.625	1.625	2.125	2.125	2.625	N/A
	175	1.625	1.625	1.625	1.625	2.125	2.125	2.625	175	1.625	2.125	2.125	2.125	2.125	2.625	N/A
	200	1.625	1.625	1.625	1.625	2.125	2.125	2.625	200	2.125	2.125	2.125	2.125	2.125	2.625	N/A
	225	1.625	1.625	1.625	2.125	2.125	2.125	2.625	225	2.125	2.125	2.125	2.125	2.125	N/A	N/A
	250	1.625	1.625	1.625	2.125	2.125	2.125	2.625	250	2.125	2.125	2.125	2.125	2.625	N/A	N/A
	275	1.625	1.625	2.125	2.125	2.125	2.125	2.625	275	2.125	2.125	2.125	2.125	2.625	N/A	N/A
300	1.625	2.125	2.125	2.125	2.125	2.125	2.625	300	2.125	2.125	2.125	2.125	2.625	N/A	N/A	

Table 11 Liquid Line Sizes for Remote Evaporators (typical type L copper O.D.)

### Line Sizing

To determine the appropriate outside diameter for field installed liquid and suction lines, it is first necessary to establish the equivalent length of pipe for each line. It is also necessary to know the capacity (tons) of each circuit. Circuit capacities for each RTAC unit are listed in the General Data Tables in Section 1.



# Installation - Mechanical

## Remote Evaporator Option

**Table 12** Equivalent Lengths of Non-Ferrous Valves and Fittings (feet)

Line Size Inches OD	Globe Valve	Short Angle Valve	Short Radius ELL	Long Radius ELL
1-1/8	87	29	2.7	1.9
1-3/8	102	33	3.2	2.2
1-5/8	115	34	3.8	2.6
2-1/8	141	39	5.2	3.4
2-5/8	159	44	6.5	4.2
3-1/8	185	53	8	5.1
3-5/8	216	66	10	6.3
4-1/8	248	76	12	7.3

### Liquid Line Sizing Steps

The steps to compute liquid line size are as follows:

1. Compute the actual length of field installed piping.
2. Multiply the length from step # 1 by 1.5 to estimate the equivalent length.
3. Refer to [Table 11](#) to determine the outside diameter that corresponds to the equivalent length computed in step # 2 for the height and leaving water temperature of interest.

Note: If the condenser is at the same elevation or above the evap, use the 0 ft. column.

4. With the outside diameter found in step # 3, use [Table 12](#) to determine the equivalent lengths of each fitting in the field installed piping.
5. Sum the equivalent lengths of all the field installed elbows and valves.
6. Add the length found in step # 5 to the actual length from step # 1. This is your new equivalent line length.
7. Using [Table 11](#) again, find the outside diameter that corresponds to the new equivalent line length from step # 6. If it is the same as step #3, this is the final equivalent length. Otherwise, proceed to the next step.
8. Using [Table 12](#) and the new outside diameter found in step # 7, find the equivalent line length of each valve and fitting, and sum them.
9. Add the length found in step # 8 to the actual length from step # 1. This is the new equivalent line length.
10. With the equivalent line length found in step # 9, use [Table 11](#) to select the proper outside diameter for the liquid lines. If the same as in step #7, this is your final equivalent line length. Otherwise, repeat step #7.

# Installation - Mechanical

## Remote Evaporator Option

Required Length in Feet of Field Installed Suction Line Accumulator

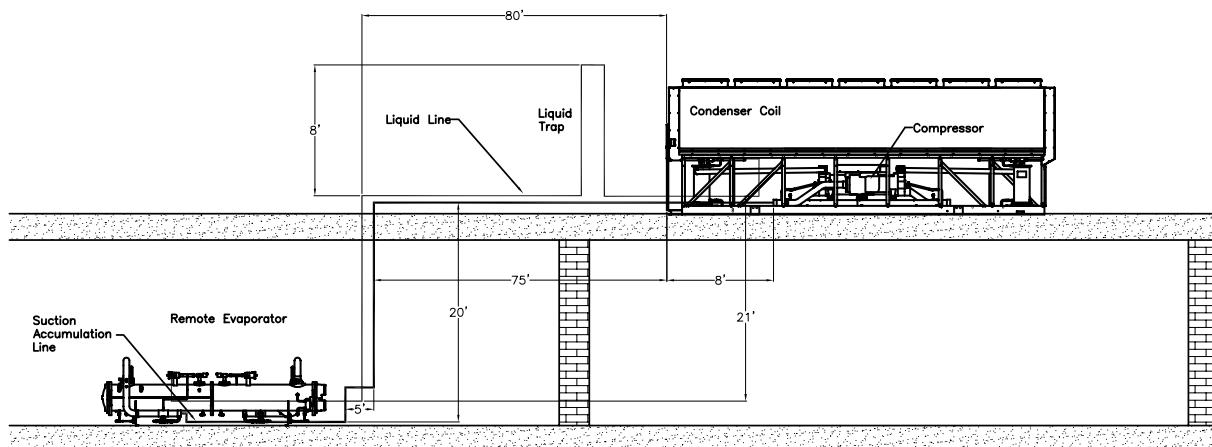
Actual ft of field installed liquid line	70 Ton Circuit <sup>(1)</sup>			85 Ton Circuit			100 Ton Circuit			120 Ton Circuit		
	1 3/8" O.D. Field Installed Liquid Line	1 5/8" O.D. Field Installed Liquid Line	2 1/8" O.D. Field Installed Liquid Line	1 3/8" O.D. Field Installed Liquid Line	1 5/8" O.D. Field Installed Liquid Line	2 1/8" O.D. Field Installed Liquid Line	1 5/8" O.D. Field Installed Liquid Line	2 1/8" O.D. Field Installed Liquid Line	2 5/8" O.D. Field Installed Liquid Line	1 5/8" O.D. Field Installed Liquid Line	2 1/8" O.D. Field Installed Liquid Line	2 5/8" O.D. Field Installed Liquid Line
	Length of 3 5/8" Suction Accumulator			Length of 3 5/8" Suction Accumulator			Length of 4 1/8" Suction Accumulator			Length of 4 1/8" Suction Accumulator		
10	43	44	45	52	52	53	43	44	46	52	53	54
20	45	46	49	53	54	57	45	47	50	53	55	58
30	46	48	52	54	56	60	46	49	53	55	58	62
40	48	50	55	56	58	63	48	52	57	56	60	66
50	49	52	59	57	60	67	49	55	61	58	63	70
60	51	54	62	59	62	70	51	57	65	59	66	74
70	52	56	65	60	64	73	53	60	69	61	68	78
80	53	58	69	62	66	77	54	62	73	62	71	81
90	55	60	72	63	68	80	56	65	77	64	73	85
100	56	62	75	64	70	83	57	68	81	66	76	89
110	58	64	79	66	72	87	59	70	85	67	79	93
120	59	66	82	67	74	90	60	73	89	69	81	97
130	61	68	85	69	76	93	62	75	93	70	84	101
140	62	70	89	70	78	97	63	78	97	72	86	105
150	64	72	92	72	80	100	65	81	101	73	89	109
160	65	74	95	73	82	103	67	83	105	75	92	113
170	66	76	99	75	84	107	68	86	108	76	94	117
180	68	78	102	76	86	110	70	88	112	78	97	121
190	69	79	105	77	88	113	71	91	116	80	99	125
200	71	81	109	79	90	117	73	94	120	81	102	129

(1) Note: Circuit 2 (M1) of 155 Ton Premium Unit requires an additional 10 feet of Suction Accumulator length.

**Table 13 Required Length of Field Installed Suction Accumulator**

*NOTE: Location and quantity of suction accumulator is dependent upon the unit configuration.*

### Example Liquid Line Sizing



**Figure 28 Liquid Line Sizing Example**



# Installation - Mechanical

## Remote Evaporator Option

For this example, refer to [Table 11](#), [Table 12](#) and [Figure 28](#). Assume a 70 ton circuit and a leaving water temperature of 49 degrees F.

- From [Figure 28](#), the actual length of field installed piping is:

$$80 + 8 + 8 + 21 = 117 \text{ feet}$$

- Estimate equivalent line length:

$$117 \text{ feet} \times 1.5 = 175 \text{ feet}$$

- From [Table 11](#) for a 70 ton circuit, for 175 equivalent feet the OD is 1.375 inches.

Note: use the 0 ft. column since the condenser is above the evap

- In [Figure 28](#) there are six long-radius elbows. From [Table 12](#), for 1.375 inch elbows, the equivalent feet is:

$$6 \text{ elbows} \times 2.2 \text{ feet} = 13.2 \text{ feet}$$

- Adding equivalent feet from step #4 to step #1 gives:

$$13.2 \text{ feet} + 117 \text{ feet} = 130.2 \text{ feet}$$

- From [Table 11](#), for a 70 ton circuit, for 125 equivalent feet (nearest to 130.2), the O.D. is 1- 3/8 inches.

$$\text{Liquid Line size} = 1\text{-}3/8 \text{ inches}$$

### Suction Line Sizing Steps

**Table 14 Suction Line Sizes**

Vertical/Upflow and Horizontal/Downflow Suction Lines O.D. (Type L Copper)				
LWT (F)	70 ton circuit	85ton circuit	100 ton circuit	120 ton circuit
40 - 60	3 5/8"	3 5/8"	4 1/8"	4 1/8"

The steps to compute suction line size are as follows:

- Break the suction line into it's Vertical/Upflow and Horizontal/Downflow components.
- From [Table 14](#), select the appropriate Vertical/Upflow suction line outside diameter according to the circuit tonnage. This is the diameter of the upflow suction line and any fittings in the upflow line.
- From [Table 14](#), select the appropriate Horizontal/Downflow suction line outside diameter according to the circuit tonnage. This is the diameter of the upflow suction line and any fittings in the upflow line.

*NOTE: The diameters of the upflow, and horizontal or downflow portions of the suction line may differ depending on the application.*

### Example Suction Line Sizing

For this example, refer to [Table 14](#) and [Figure 28](#) assume a 70 ton circuit and a leaving water temperature of 49 degrees F.

- From [Table 14](#), the vertical/upflow suction line is: 3 5/8" O.D.
- From [Table 14](#), the horizontal/downflow line is: 3 5/8" O.D.

*NOTE: In this example, the horizontal line is pitched downward in the direction of flow.*



# Installation - Mechanical

## Remote Evaporator Option

---

### Suction Accumulator Sizing

Use [Table 13](#) to calculate length and size of the required suction accumulator(s).

#### Example of Suction Accumulator Line Sizing

Use [Figure 28](#) and the same assumptions from the liquid line sizing example to calculate the suction accumulator line size and length.

In this case the accumulator is installed at the evaporator.

1. Use the 70 ton circuit column.
2. From the liquid line sizing example, use a field installed liquid line of: 1.375 (1 3/8") inches
3. The actual feet of liquid line installed is: 117 feet
4. The size of the suction accumulator is: 3 5/8 inches
5. The length of the suction line accumulator is: 59 feet

### Piping Installation Procedures

The outdoor unit and the evaporator are shipped with a 25 psig holding pressure of dry nitrogen. Do not relieve this pressure until field installation of the refrigerant piping is to be accomplished. This will require the removal of the temporary pipe caps.

*NOTE: Use Type L refrigerant-grade copper tubing only.*

The refrigerant lines must be isolated to prevent line vibration from being transferred to the building. Do not secure the lines rigidly to the building at any point.

All horizontal suction lines should be pitched downward, in the direction of flow, at a slope of 1/2 inch per 10 feet of run.

Do not use a saw to remove end caps, as this may allow copper chips to contaminate the system. Use a tubing cutter or heat to remove the end caps.

When sweating copper joints, flow dry nitrogen through the system. This prevents scale formation and the possible formation of an explosive mixture of R-134a and air. This will also prevent the formation of toxic phosgene gas, which occurs when refrigerant is exposed to open flame.

### **⚠ WARNING** **Hazardous Gas!**

**To prevent injury or death, due to explosion and/or inhalation of phosgene gas, purge the system thoroughly with dry nitrogen while sweating connections. Use a pressure regulator in the line between the unit and the high pressure nitrogen cylinder to avoid over-pressurization and possible explosion. Failure to use a nitrogen purge and pressure regulator could result in death or serious injury or equipment damage.**



# Installation - Mechanical

## Remote Evaporator Option

### Refrigerant Sensors

All necessary refrigerant devices, transducers and solenoids are factory installed and wired to the evaporator terminal box.

### Refrigerant Pressure Relief Valve Venting

#### **⚠ WARNING**

#### **Hazardous Gases!**

**Consult local regulations for any special relief line requirements. Refrigerant vented into a confined equipment room could displace available oxygen to breathe, causing possible asphyxiation or other serious health risks. Failure to follow these recommendations could result in death or serious injury.**

Vent pipe size must conform to the ANSI/ASHRAE Standard 15 for vent pipe sizing. All federal, state, and local codes take precedence over any suggestions stated in this manual.

All relief valve venting is the responsibility of the installing contractor.

All RTAC remote evaporator units use evaporator pressure relief valves (Figure 29) that must be vented to the outside of the building.

Relief valve connection sizes and locations are shown in the unit submittals. Refer to local codes for relief valve vent line sizing information.

#### **Caution**

#### **Equipment Damage!**

**Do not exceed vent piping code specifications. Failure to comply with specifications may result in capacity reduction, unit damage and/or relief valve damage.**

Relief valve discharge setpoints and capacities rates are given in Table 12. Once the relief valve has opened, it will re-close when pressure is reduced to a safe level.

Once opened, relief valves may have a tendency to leak and must be replaced.

Pressure relief valve discharge capacities will vary with shell diameter and length and also compressor displacement. Discharge venting capacity should be calculated as required by ASHRAE Standard 15-94. Do not adjust relief valve setting in the field.

**Table 15 Pressure Relief Valve Data**

Valve Location	Discharge Setpoint (psi)	Number of Valves	Rated Capacity per Relief Valve (lba/min.)	Field Connection Pipe Size (in NPT)	Factory Shell Side Connection (in)
Evap	200	2	28.9	3/4	7/8 - 14

#### **Leak Test and Evacuation**

After installation of the refrigerant piping, thoroughly test the system for leaks. Pressure test the system at pressures required by local codes.

# Installation - Mechanical

## Remote Evaporator Option

### ⚠ WARNING

#### Hazard of Explosion!

Use only dry nitrogen with a pressure regulator for pressurizing unit. Do not use acetylene, oxygen or compressed air or mixtures containing them for pressure testing. Do not use mixtures of a hydrogen containing refrigerant and air above atmospheric pressure for pressure testing as they may become flammable and could result in an explosion. Refrigerant, when used as a trace gas should only be mixed with dry nitrogen for pressurizing units. Failure to follow these recommendations could result in death or serious injury or equipment or property-only damage.

For field evacuation, use a rotary-type vacuum pump capable of pulling a vacuum of 500 microns or less. Follow the pump manufacturer's instructions for proper use of the pump. The line used to connect the pump to the system should be copper and be the largest diameter that can be practically used. A larger line size with minimum flow resistance can significantly reduce evacuation time.

Use the ports on the suction service valves and the liquid line shutoff valves for access to the system for evacuation. Ensure that the suction service valve, the liquid line shutoff valve, the oil line shutoff valve and any field installed valves are open in the proper position before evacuating.

Insulate the entire suction line and the suction accumulator line. Where the line is exposed to the weather, wrap it with weatherproof tape and seal with weatherproof compound.

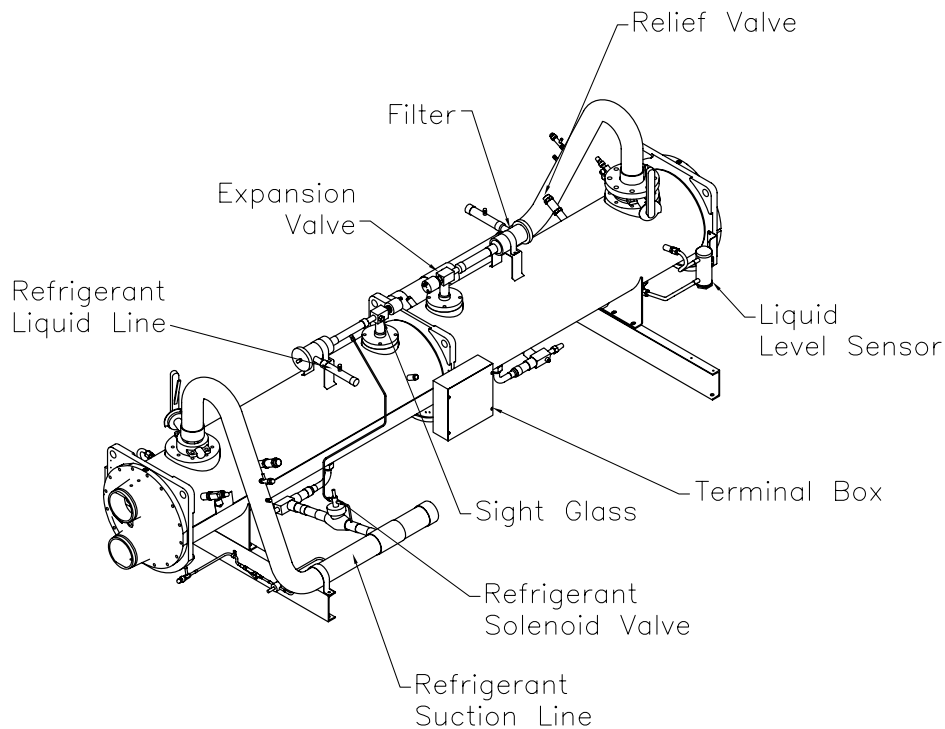
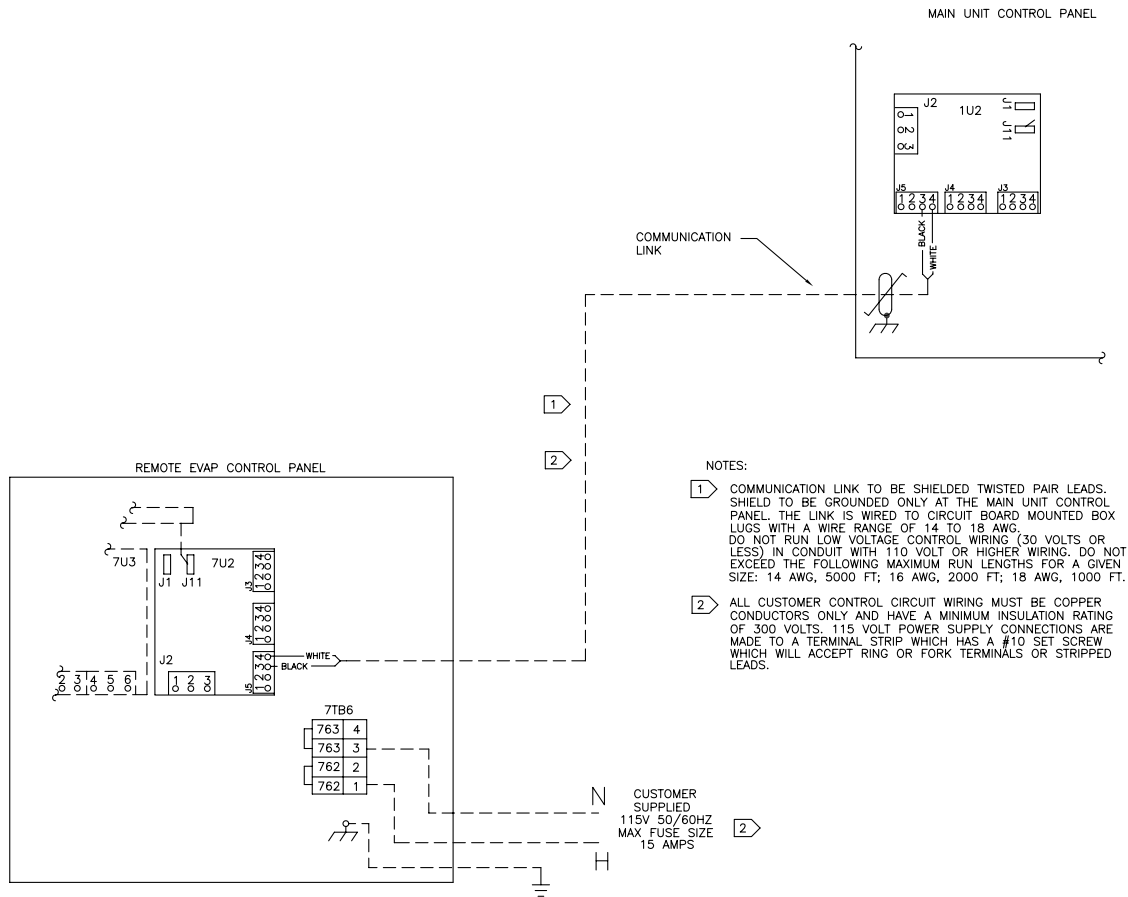


Figure 29 Remote Evaporator

# Installation - Mechanical

## Remote Evaporator Option



**Figure 30** Field Wiring between Remote Evaporator and Condensing Unit

## Refrigerant and Additional Oil Charge

### Refrigerant Charge Determination

The approximate amount of refrigerant charge required by the system must be determined by referring to [Table 16](#) and must be verified by running the system and checking subcooling.

**Table 16** Field Installed Piping Charge

Pipe O.D. (in)	Suction Line lbs of R134a per 100ft	Liquid Line lbs of R134a per 100ft
1-3/8	N/A	62.4
1-5/8	N/A	88.3
2-1/8	N/A	153.6
2-5/8	N/A	236.9
3-1/8	5.0	N/A
3-5/8	6.8	N/A
4-1/8	8.8	N/A



## Installation - Mechanical Remote Evaporator Option

---

1. To determine the appropriate charge, first refer to the General Data Tables in Section 1 to establish the required charge without the field-installed piping.
2. Next, determine the charge required for the field-installed piping by referring to [Table 16](#).
3. Sum the values of step 1 and step 2 to determine the circuit charge.

*NOTE: The amounts of refrigerant listed in [Table 16](#) are per 100 feet of pipe. Requirements will be in direct proportion to the actual length of piping.*

### **Oil Charge Determination**

The unit is factory charged with the amount of oil required by the system, without the field-installed piping. The amount of the additional oil required is dependent upon the amount of refrigerant that is added to the system for the field installed piping.

Use the following formula to calculate the amount of oil to be added:

Pints of Oil = [lbs of R-134a added for field-installed piping]/100



## Installation - Electrical

---

### General Recommendations

All wiring must comply with local codes and the National Electric Code. Typical field wiring diagrams are included at the end of the manual. Minimum circuit ampacities and other unit electrical data are on the unit nameplate and in [Table 17](#) through [Table 19](#). See the unit order specifications for actual electrical data. Specific electrical schematics and connection diagrams are shipped with the unit.

### **⚠ WARNING**

#### **Hazardous Voltage w/Capacitors!**

**Disconnect all electric power, including remote disconnects before servicing. Follow proper lockout/tagout procedures to ensure the power cannot be inadvertently energized. For variable frequency drives or other energy storing components provided by Trane or others, refer to the appropriate manufacturer's literature for allowable waiting periods for discharge of capacitors. Verify with an appropriate voltmeter that all capacitors have discharged. Failure to disconnect power and discharge capacitors before servicing could result in death or serious injury.**

**Note: For additional information regarding the safe discharge of capacitors, see PROD-SVB06A-EN or PROD-SVB06A-FR**

### **CAUTION**

#### **Use Copper Conductors Only!**

**Unit terminals are not designed to accept other types of conductors. Failure to use copper conductors may result in equipment damage.**

#### **Important!**

**Do not allow conduit to interfere with other components, structural members or equipment. Control voltage (115V) wiring in conduit must be separate from conduit carrying low voltage (<30V) wiring.**

**Caution: To prevent control malfunctions, do not run low voltage wiring (<30V) in conduit with conductors carrying more than 30 volts.**



# Installation - Electrical

**Table 17 Unit Electrical Data for Std. Efficiency at All Ambient Operation**

Unit Size	Rated Voltage	# of Power Conns (1)	Unit Wiring			Motor Data							
			MCA (3) Ckt1/Ckt2	Max. Fuse, HACR Breaker or MOP (11) Ckt1/Ckt2	Rec. Time Delay or RDE (4) Ckt1/Ckt2	Compressor (Each)			Fans (Each)				
						Qty	RLA (5) Ckt1/Ckt2	XLRA (8) Ckt1/Ckt2	YLRA (8) Ckt1/Ckt2	Qty. Ckt1/Ckt2	kW	FLA	Control VA (7)
<b>RTAC 140</b>	200/60/3	1	660	800	800	2	270-270	1498-1498	487-487	8	1.5	6.5	0.83
	200/60/3	2	364/364	600/600	450/450	2	270/270	1498/1498	487/487	4/4	1.5	6.5	0.83
	230/60/3	1	581	800	700	2	235-235	1314-1314	427-427	8	1.5	6.5	0.83
	230/60/3	2	320/320	500/500	400/400	2	235/235	1314/1314	427/427	4/4	1.5	6.5	0.83
	380/60/3	1	348	450	400	2	142-142	801-801	260-260	8	1.5	3.5	0.83
	380/60/3	2	192/192	300/300	250/250	2	142/142	801/801	260/260	4/4	1.5	3.5	0.83
	460/60/3	1	290	400	350	2	118-118	652-652	212-212	8	1.5	3.0	0.83
	460/60/3	2	160/160	250/250	200/200	2	118/118	652/652	212/212	4/4	1.5	3.0	0.83
	575/60/3	1	232	300	300	2	94-94	520-520	172-172	8	1.5	2.5	0.83
	575/60/3	2	128/128	200/200	175/175	2	94/94	520/520	172/172	4/4	1.5	2.5	0.83
	400/50/3	1	333	450	400	2	138-138	774-774	259-259	8	0.9	2.8	0.83
	400/50/3	2	184/184	300/300	250/250	2	138/138	774/774	259/259	4/4	0.9	2.8	0.83
<b>RTAC 155</b>	200/60/3	1	730	1000	1000	2	320-270	1845-1498	600-701	9	1.5	6.5	0.83
	200/60/3	2	433/364	700/600	600/450	2	320/270	1845/1498	600/701	5/4	1.5	6.5	0.83
	230/60/3	1	641	800	800	2	278-235	1556-1314	506-571	9	1.5	6.5	0.83
	230/60/3	2	380/320	600/500	450/400	2	278/235	1556/1314	506/571	5/4	1.5	6.5	0.83
	380/60/3	1	380	500	450	2	168-142	973-801	316-260	9	1.5	3.5	0.83
	380/60/3	2	228/192	350/300	300/250	2	168/142	973/801	316/260	5/4	1.5	3.5	0.83
	460/60/3	1	319	450	400	2	139-118	774-652	252-212	9	1.5	3.0	0.83
	460/60/3	2	189/160	300/250	225/200	2	139/118	774/652	252/212	5/4	1.5	3.0	0.83
	575/60/3	1	255	350	300	2	111-94	631-528	205-172	9	1.5	2.5	0.83
	575/60/3	2	152/128	250/200	200/175	2	111/94	631/528	205/172	5/4	1.5	2.5	0.83
	400/50/3	1	373	500	450	2	168-138	896-796	291-259	9	0.9	2.8	0.83
	400/50/3	2	224/184	350/300	300/250	2	168/138	896/796	291/259	5/4	0.9	2.8	0.83
<b>RTAC 170</b>	200/60/3	1	785	1000	1000	2	320-320	1845-1845	600-600	10	1.5	6.5	0.83
	200/60/3	2	433/433	700/700	600/600	2	320/320	1845/1845	600/600	5/5	1.5	6.5	0.83
	230/60/3	1	691	800	800	2	278-278	1556-1556	506-506	10	1.5	6.5	0.83
	230/60/3	2	380/380	600/600	450/450	2	278/278	1556/1556	506/506	5/5	1.5	6.5	0.83
	380/60/3	1	413	500	500	2	168-168	973-973	316-316	10	1.5	3.5	0.83
	380/60/3	2	228/228	350/350	300/300	2	168/168	973/973	316/316	5/5	1.5	3.5	0.83
	460/60/3	1	343	450	400	2	139-139	774-774	252-252	10	1.5	3.0	0.83
	460/60/3	2	189/189	300/300	225/225	2	139/139	774/774	252/252	5/5	1.5	3.0	0.83
	575/60/3	1	275	350	350	2	111-111	631-631	205-205	10	1.5	2.5	0.83
	575/60/3	2	152/152	250/250	200/200	2	111/111	631/631	205/205	5/5	1.5	2.5	0.83
	400/50/3	1	406	500	450	2	168-168	896-896	291-291	10	0.9	2.8	0.83
	400/50/3	2	224/224	350/350	300/300	2	168/168	896/896	291/291	5/5	0.9	2.8	0.83
<b>RTAC 185</b>	200/60/3	1	874	1200	1000	2	386-320	2156-1845	701-600	11	1.5	6.5	0.83
	200/60/3	2	522/433	800/700	700/600	2	386/320	2156/1845	701/600	6/5	1.5	6.5	0.83
	230/60/3	1	770	1000	1000	2	336-278	1756-1556	571-506	11	1.5	6.5	0.83
	230/60/3	2	459/380	700/600	600/450	2	336/278	1756/1556	571/506	6/5	1.5	6.5	0.83
	380/60/3	1	460	600	600	2	203-168	1060-973	345-316	11	1.5	3.5	0.83
	380/60/3	2	275/228	450/350	350/300	2	203/168	1060/973	345/316	6/5	1.5	3.5	0.83
	460/60/3	1	382	500	450	2	168-139	878-774	285-252	11	1.5	3.0	0.83
	460/60/3	2	228/189	350/300	300/225	2	168/139	878/774	285/252	6/5	1.5	3.0	0.83
	575/60/3	1	306	400	350	2	134-111	705-631	229-205	11	1.5	2.5	0.83
	575/60/3	2	183/152	300/250	225/200	2	134/111	705/631	229/205	6/5	1.5	2.5	0.83
	400/50/3	1	446	600	500	2	198-168	1089-896	354-291	11	0.9	2.8	0.83
	400/50/3	2	264/224	450/350	350/300	2	198/168	1089/896	354/291	6/5	0.9	2.8	0.83



# Installation - Electrical

**Table 17 Unit Electrical Data for Std. Efficiency at All Ambient Operation**

Unit Size	Rated Voltage	Unit Wiring			Motor Data								
		# of Power Conns (1)	MCA (3) Ckt1/Ckt2	Max. Fuse, HACR Breaker or MOP (11) Ckt1/Ckt2	Rec. Time Delay or RDE (4) Ckt1/Ckt2	Compressor (Each)			Fans (Each)				
						Qty	RLA (5) Ckt1/Ckt2	XLRA (8) Ckt1/Ckt2	YLRA (8) Ckt1/Ckt2	Qty. Ckt1/Ckt2	kW	FLA	Control VA (7)
<b>RTAC 200</b>	200/60/3	1	947	1200	1200	2	386-386	2156-2156	701-701	12	1.5	6.5	0.83
	200/60/3	2	522/522	800/800	700/700	2	386/386	2156/2156	701/701	6/6	1.5	6.5	0.83
	230/60/3	1	834	1000	1000	2	336-336	1756-1756	571-571	12	1.5	6.5	0.83
	230/60/3	2	459/459	700/700	600/600	2	336/336	1756/1756	571/571	6/6	1.5	6.5	0.83
	380/60/3	1	499	700	600	2	203-203	1060-1060	345-345	12	1.5	3.5	0.83
	380/60/3	2	275/275	450/450	350/350	2	203/203	1060/1060	345/345	6/6	1.5	3.5	0.83
	460/60/3	1	414	500	500	2	168-168	878-878	285-285	12	1.5	3.0	0.83
	460/60/3	2	228/228	350/350	300/300	2	168/168	878/878	285/285	6/6	1.5	3.0	0.83
	575/60/3	1	323	450	400	2	134-134	705-705	229-229	12	1.5	2.5	0.83
	575/60/3	2	183/183	300/300	225/225	2	134/134	705/705	229/229	6/6	1.5	2.5	0.83
400/50/3	1	479	600	600	2	198-198	1089-1089	354-354	12	0.9	2.8	0.83	
400/50/3	2	264/264	450/450	350/350	2	198/198	1089/1089	354/354	6/6	0.9	2.8	0.83	
<b>RTAC 225</b>	200/60/3	1	1045	1200	1200	2	459-386	2525-2156	821-701	13	1.5	6.5	0.83
	200/60/3	2	620/522	1000/800	800/700	2	459/386	2525/2156	821/701	7/6	1.5	6.5	0.83
	230/60/3	1	920	1200	1200	2	399-336	2126-1756	691-571	13	1.5	6.5	0.83
	230/60/3	2	545/459	800/700	700/600	2	399/336	2126/1756	691/571	7/6	1.5	6.5	0.83
	380/60/3	1	551	700	700	2	242-203	1306-1060	424-345	13	1.5	3.5	0.83
	380/60/3	2	327/275	500/450	400/350	2	242/203	1306/1060	424/345	7/6	1.5	3.5	0.83
	460/60/3	1	457	600	600	2	200-168	1065-878	346-285	13	1.5	3.0	0.83
	460/60/3	2	271/228	450/350	350/300	2	200/168	1065/878	346/285	7/6	1.5	3.0	0.83
	575/60/3	1	367	500	450	2	160-134	853-705	277-229	13	1.5	2.5	0.83
	575/60/3	2	218/183	350/300	300/225	2	160/134	853/705	277/229	7/6	1.5	2.5	0.83
<b>RTAC 250</b>	200/60/3	1	1124	1200	1200	2	459-459	2525-2525	821-821	14	1.5	6.5	0.83
	200/60/3	2	620/620	1000/1000	800/800	2	459/459	2525/2525	821/821	7/7	1.5	6.5	0.83
	230/60/3	1	989	1200	1200	2	399-399	2126-2126	691-691	14	1.5	6.5	0.83
	230/60/3	2	545/545	800/800	700/700	2	399/399	2126/2126	691/691	7/7	1.5	6.5	0.83
	380/60/3	1	594	800	700	2	242-242	1306-1306	424-424	14	1.5	3.5	0.83
	380/60/3	2	327/327	500/500	400/400	2	242/242	1306/1306	424/424	7/7	1.5	3.5	0.83
	460/60/3	1	492	600	600	2	200-200	1065-1065	346-346	14	1.5	3.0	0.83
	460/60/3	2	271/271	450/450	350/350	2	200/200	1065/1065	346/346	7/7	1.5	3.0	0.83
	575/60/3	1	395	500	500	2	160-160	853-853	277-277	14	1.5	2.5	0.83
	575/60/3	2	218/218	350/350	300/300	2	160/160	853/853	277/277	7/7	1.5	2.5	0.83
400/50/3	1	563	700	700	3	138-138-198	796-796-1089	259-259-354	14	0.9	2.8	1.2	
400/50/3	2	333/265	450/450	400/350	3	138/138/198	796/796/1089	259/259/354	8/6	0.9	2.8	1.2	
<b>RTAC 275</b>	200/60/3	1	NA										
	200/60/3	2	785/522	1000/800	1000/700	3	320/320/386	1845/1845/2156	600/600/701	10/6	1.5	6.5	1.2
	230/60/3	1	NA										
	230/60/3	2	681/459	800/700	800/600	3	278/278/336	1556/1556/1756	506/506/571	10/6	1.5	6.5	1.2
	380/60/3	1	NA										
	380/60/3	2	413/275	500/450	500/350	3	168/168/203	973/973/1060	316/316/345	10/6	1.5	3.5	1.2
	460/60/3	1	536	700	600	3	139-139-168	774-774-878	252-252-285	16	1.5	3.0	1.2
	460/60/3	2	343/228	450/350	400/300	3	139/139/168	774/774/878	252/252/285	10/6	1.5	3.0	1.2
	575/60/3	1	430	500	500	3	111-111-134	631-631-705	205-205-229	16	1.5	2.5	1.2
	575/60/3	2	275/183	350/300	350/225	3	111-111/134	631/631/705	205/205/229	10/6	1.5	2.5	1.2
400/50/3	1	629	800	700	3	168-168-198	896-896-1089	291-291-354	16	0.9	2.8	1.2	
400/50/3	2	406/265	500/450	450/350	3	168/168/198	896/896/1089	291/291/254	10/6	0.9	2.8	1.2	



# Installation - Electrical

**Table 17 Unit Electrical Data for Std. Efficiency at All Ambient Operation**

Unit Size	Rated Voltage	# of Power Conns (1)	Unit Wiring			Motor Data								
			MCA (3) Ckt1/Ckt2	Max. Fuse, HACR Breaker or MOP (11) Ckt1/Ckt2	Rec. Time Delay or RDE (4) Ckt1/Ckt2	Compressor (Each)			Fans (Each)		Control VA (7)			
						Qty	RLA (5) Ckt1/Ckt2	XLRA (8) Ckt1/Ckt2	YLRA (8) Ckt1/Ckt2	Qty. Ckt1/Ckt2		kW		
<b>RTAC 300</b>	200/60/3	1	NA											
	200/60/3	2	947/522	1200/800	1200/700	3	386/386/386	2156/2156/2156	701/701/701	12/6	1.5	6.5	1.2	
	230/60/3	1	NA											
	230/60/3	2	834/459	1000/700	1000/600	3	336/336/336	1756/1756/1756	571/571/571	12/6	1.5	6.5	1.2	
	380/60/3	1	NA											
	380/60/3	2	499/275	700/450	600/350	3	203/203/203	1060/1060/1060	345/345/345	12/6	1.5	3.5	1.2	
	460/60/3	1	600	700	700	3	168-168-168	878-878-878	285-285-285	18	1.5	3.0	1.2	
	460/60/3	2	414/228	500/350	500/300	3	168/168/168	878/878/878	285/285/285	12/6	1.5	3.0	1.2	
	575/60/3	1	481	600	600	3	134-134-134	705-705-705	229-229-229	18	1.5	2.5	1.2	
	575/60/3	2	332/183	450/300	400/225	3	134/134/134	705/705/705	229/229/229	12/6	1.5	2.5	1.2	
<b>RTAC 350</b>	400/50/3	1	694	800	800	3	198-198-198	1089-1089-1089	354-354-354	18	0.9	2.8	1.2	
	400/50/3	2	480/265	600/450	600/350	3	198/198/198	1089/1089/1089	354/354/354	12/6	0.9	2.8	1.2	
	200/60/3	1	NA											
	200/60/3	2	1124/522	1200/800	1200/700	3	459/459/386	1845/1845/1845/1845	821/821/701	14/6	1.5	6.5	1.2	
	230/60/3	1	NA											
	230/60/3	2	989/459	1200/700	1200/600	3	399/399/336	1556/1556/1556/1556	691/691/571	14/6	1.5	6.5	1.2	
	380/60/3	1	NA											
	380/60/3	2	594/275	800/450	700/350	3	242/242/203	973/973/973/973	424/424/345	14/6	1.5	3.5	1.2	
	460/60/3	1	678	800	800	3	200-200-168	774-774-774-774	346-346-285	20	1.5	3.0	1.2	
	460/60/3	2	492/228	600/350	600/300	3	200/200/168	774/774/774/774	346/346/285	14/6	1.5	3.0	1.2	
<b>RTAC 375</b>	575/60/3	1	544	700	600	3	160-160-134	631-631-631-631	277-277-229	20	1.5	2.5	1.2	
	575/60/3	2	395/183	500/300	450/225	3	160/160/134	631/631/631/631	277/277/229	14/6	1.5	2.5	1.2	
	400/50/3	1	770	800	800	4	168-168-168-168	896-896-896-896	291-291-291-291	20	0.9	2.8	1.59	
	400/50/3	2	406/406	500/500	450/450	4	168/168/168/168	896/896/896/896	291/291/291/291	10/10	0.9	2.8	1.59	
	400/50/3	1	844	1000	1000	4	198-198-168-168	1089-1089-896-896	354-354-291-291	22	0.9	2.8	1.59	
	400/50/3	2	480/406	600/500	600/450	4	198/198/168/168	1089/1089/896/896	354/354/291/291	12/10	0.9	2.8	1.59	
	<b>RTAC 400</b>	200/60/3	1	NA										
		200/60/3	2	947/947	1200/1200	1200/1200	4	386/386/386/386	2156/2156/2156/2156	701/701/701/701	14/14	1.5	6.5	1.59
		230/60/3	1	NA										
		230/60/3	2	834/834	1000/1000	1000/1000	4	336/336/336/336	1756/1756/1756/1756	571/571/571/571	14/14	1.5	6.5	1.59
380/60/3		1	NA											
380/60/3		2	499/499	700/700	600/600	4	203/203/203/203	1060/1060/1060/1060	345/345/345/345	14/14	1.5	3.5	1.59	
460/60/3		1	786	800	800	4	168-168-168-168	878-878-878-878	285-285-285-285	28	1.5	3.0	1.59	
460/60/3		2	414/414	500/500	500/500	4	168/168/168/168	878/878/878/878	285/285/285/285	14/14	1.5	3.0	1.59	
575/60/3		1	630	700	700	4	134-134-134-134	705-705-705-705	229-229-229-229	28	1.5	2.5	1.59	
575/60/3		2	332/332	450/450	400/400	4	134/134/134/134	705/705/705/705	229/229/229/229	14/14	1.5	2.5	1.59	
<b>RTAC 400</b>	400/50/3	1	909	1000	1000	4	198-198-198-198	1089-1089-1089-1089	354-354-354-354	28	0.9	2.8	1.59	
	400/50/3	2	480/480	600/600	600/600	4	198/198/198/198	1089/1089/1089/1089	354/354/354/354	14/14	0.9	2.8	1.59	



# Installation - Electrical

**Table 17 Unit Electrical Data for Std. Efficiency at All Ambient Operation**

Unit Size	Rated Voltage	# of Power Conns (1)	Unit Wiring			Motor Data								
			MCA (3) Ckt1/Ckt2	Max. Fuse, HACR Breaker or MOP (11) Ckt1/Ckt2	Rec. Time Delay or RDE (4) Ckt1/Ckt2	Compressor (Each)			Fans (Each)		Control VA (7)			
						Qty	RLA (5) Ckt1/Ckt2	XLRA (8) Ckt1/Ckt2	YLRA (8) Ckt1/Ckt2	Qty. Ckt1/Ckt2		kW		
<b>RTAC 450</b>	200/60/3	1	NA											
	200/60/3	2	1124/947	1200/1200	1200/1200	4	459/459/386/386	2525/2525/2156/2156	821/821/701/701	14/12	1.5	6.5	1.59	
	230/60/3	1	NA											
	230/60/3	2	989/834	1200/1000	1200/1000	4	399/399/336/336	2126/2126/1756/1756	691/691/571/571	14/12	1.5	6.5	1.59	
	380/60/3	1	NA											
	380/60/3	2	594/499	800/700	700/600	4	242/242/203/203	1306/1306/1060/1060	424/424/345/345	14/12	1.5	3.5	1.59	
	460/60/3	1	864	1000	1000	4	200-200-168-168	1065-1065-878-878	346-346-285-285	26	1.5	3.0	1.59	
	460/60/3	2	492/414	600/500	600/500	4	200/200/168/168	1065/1065/878/878	346/346/285/285	14/12	1.5	3.0	1.59	
<b>RTAC 500</b>	200/60/3	1	NA											
	200/60/3	2	1124/1124	1200/1200	1200/1200	4	459/459/459/459	2525/2525/2525/2525	821/821/821/821	14/14	1.5	6.5	1.59	
	230/60/3	1	NA											
	230/60/3	2	989/989	1200/1200	1200/1200	4	399/399/399/399	2126/2126/2126/2126	691/691/691/691	14/14	1.5	6.5	1.59	
	380/60/3	1	NA											
	380/60/3	2	594/594	800/800	700/700	4	242/242/242/242	1306/1306/1306/1306	424/424/424/424	14/14	1.5	3.5	1.59	
	460/60/3	1	929	1000	1000	4	200-200-200-200	1065-1065-1065-1065	346-346-346-346	28	1.5	3.0	1.59	
	460/60/3	2	490/490	600/600	600/600	4	200/200/200/200	1065/1065/1065/1065	346/346/346/346	14/14	1.5	3.0	1.59	
<b>RTAC 500</b>	575/60/3	1	745	800	800	4	160-160-160-160	853-853-853-853	277-277-277-277	28	1.5	2.5	1.59	
	575/60/3	2	393/393	500/500	450/450	4	160/160/160/160	853/853/853/853	277/277/277/277	14/14	1.5	2.5	1.59	

**Notes:**

- As standard, 140-250 ton (60 Hz) units and 140-200 ton (50Hz) units have a single point power connection. Optional dual point power connections are available. As standard, 275-500 ton (60Hz) units and 250-400 ton (50Hz) units have dual point power connections. Optional single point power connections are available on 380V, 460V 575V/50 Hz and 400V/50 Hz units.
- Max Fuse or HACR type breaker = 225 percent of the largest compressor RLA plus 100 percent of the second compressor RLA, plus the sum of the condenser fan FLA per NEC 440-22. (Use FLA per circuit, NOT FLA for the entire unit).
- MCA - Minimum Circuit Ampacity - 125 percent of largest compressor RLA plus 100 percent of the second compressor RLA plus the sum of the condenser fans FLAs per NEC 440-33.
- RECOMMENDED TIME DELAY OR DUAL ELEMENT (RDE) FUSE SIZE: 150 percent of the largest compressor RLA plus 100 percent of the second compressor RLA and the sum of the condenser fan FLAs.
- RLA - Rated Load Amps - rated in accordance with UL Standard 1995.
- Local codes may take precedence.
- Control VA includes operational controls only. Does not include evaporator heaters.
- XLRA - Locked Rotor Amps - based on full winding (x-line) start units. YLRA for wye-delta starters is ~1/3 of LRA of x-line units.
- Voltage Utilization Range:

Rated Voltage	200/60/3	230/60/3	380/60/3	460/60/3	575/60/3	400/50/3
Use Range	180-220	208-254	342-418	414-506	516-633	360-440
- A separate 115/60/1, 20 amp or 220/50/1, 15 amp customer provided power connection is required to power the evaporator heaters (1640 watts).
- If factory circuit breakers are supplied with the chiller, then these values represent Maximum Overcurrent Protection (MOP).



# Installation - Electrical

**Table 18 Unit Electrical Data for High Efficiency at Std. Ambient Operation**

Unit Size	Rated Voltage	Unit Wiring				Motor Data							
		# of Power Conns (1)	MCA (3) Ckt1/Ckt2	Max. Fuse, HACR Breaker or MOP (11) Ckt1/Ckt2	Rec. Time Delay or RDE (4) Ckt1/Ckt 2	Compressor (Each)			Fans (Each)				
						Qty	RLA (5) Ckt1/Ckt2	XLRA (8) Ckt1/Ckt2	YLRA (8) Ckt1/Ckt2	Qty. Ckt1/Ckt2	kW	FLA	Control VA (7)
<b>RTAC 140</b>	200/60/3	1	648	800	800	2	259-259	1498-1498	487-487	10	1.5	6.5	0.83
	200/60/3	2	356/356	600/600	450/450	2	259/259	1498/1498	487/487	5/5	1.5	6.5	0.83
	230/60/3	1	572	700	700	2	225-225	1314-1314	427-427	10	1.5	6.5	0.83
	230/60/3	2	314/314	500/500	400/400	2	225/225	1314/1314	427/427	5/5	1.5	6.5	0.83
	380/60/3	1	341	450	400	2	136-136	801-801	260-260	10	1.5	3.5	0.83
	380/60/3	2	188/188	300/300	225/225	2	136/136	801/801	260/260	5/5	1.5	3.5	0.83
	460/60/3	1	285	350	350	2	113-113	652-652	212-212	10	1.5	3.0	0.83
	460/60/3	2	157/157	250/250	200/200	2	113/113	652/652	212/212	5/5	1.5	3.0	0.83
	575/60/3	1	228	300	250	2	90-90	520-520	172-172	10	1.5	2.5	0.83
	575/60/3	2	125/125	200/200	150/150	2	90/90	520/520	172/172	5/5	1.5	2.5	0.83
	400/50/3	1	325	450	400	2	132-132	774-774	259-259	10	0.9	2.8	0.83
	400/50/3	2	179/179	300/300	225/225	2	132/132	774/774	259/259	5/5	0.9	2.8	0.83
<b>RTAC 155</b>	200/60/3	1	712	1000	800	2	305-259	1845-1498	600-487	11	1.5	6.5	0.83
	200/60/3	2	421/356	700/600	500/450	2	305/259	1845/1498	600/487	6/5	1.5	6.5	0.83
	230/60/3	1	628	800	700	2	265-225	1556-1314	506-427	11	1.5	6.5	0.83
	230/60/3	2	371/314	600/500	450/400	2	265/225	1556/1314	506/427	6/5	1.5	6.5	0.83
	380/60/3	1	376	500	416	2	161-136	973-801	316-260	11	1.5	3.5	0.83
	380/60/3	2	222/188	350/300	300/225	2	161/136	973/801	316/260	6/5	1.5	3.5	0.83
	460/60/3	1	313	400	350	2	133-113	774-652	252-212	11	1.5	3.0	0.83
	460/60/3	2	185/157	300/250	225/200	2	133/113	774/652	252/212	6/5	1.5	3.0	0.83
	575/60/3	1	250	350	300	2	106-90	631-528	205-172	11	1.5	2.5	0.83
	575/60/3	2	148/125	250/200	175/150	2	106/90	631/528	205/172	6/5	1.5	2.5	0.83
	400/50/3	1	363	500	450	2	160-132	896-796	291-259	11	0.9	2.8	0.83
	400/50/3	2	217/179	350/300	300/225	2	160/132	896/796	291/259	6/5	0.9	2.8	0.83
<b>RTAC 170</b>	200/60/3	1	765	1000	1000	2	305-305	1845-1845	600-600	12	1.5	6.5	0.83
	200/60/3	2	421/421	700/700	500/500	2	305/305	1845/1845	600/600	6/6	1.5	6.5	0.83
	230/60/3	1	675	800	800	2	265-265	1556-1556	506-506	12	1.5	6.5	0.83
	230/60/3	2	371/371	600/600	450/450	2	265/265	1556/1556	506/506	6/6	1.5	6.5	0.83
	380/60/3	1	404	500	450	2	161-161	973-973	316-316	12	1.5	3.5	0.83
	380/60/3	2	222/222	350/350	300/300	2	161/161	973/973	316/316	6/6	1.5	3.5	0.83
	460/60/3	1	336	450	400	2	133-133	774-774	252-252	12	1.5	3.0	0.83
	460/60/3	2	185/185	300/300	225/225	2	133/133	774/774	252/252	6/6	1.5	3.0	0.83
	575/60/3	1	269	350	300	2	106-106	631-631	205-205	12	1.5	2.5	0.83
	575/60/3	2	148/148	250/250	175/175	2	106/106	631/631	205/205	6/6	1.5	2.5	0.83
	400/50/3	1	394	500	450	2	160-160	896-896	291-291	12	0.9	2.8	0.83
	400/50/3	2	217/217	350/350	300/300	2	160/160	896/896	291/291	6/6	0.9	2.8	0.83
<b>RTAC 185</b>	200/60/3	1	856	1200	1000	2	373-305	2156-1845	701-600	13	1.5	6.5	0.83
	200/60/3	2	512/421	800/700	700/500	2	373/305	2156/1845	701/600	7/6	1.5	6.5	0.83
	230/60/3	1	755	1000	1000	2	324-265	1756-1556	571-506	13	1.5	6.5	0.83
	230/60/3	2	451/371	700/600	600/450	2	324/265	1756/1556	571/506	7/6	1.5	6.5	0.83
	380/60/3	1	452	600	500	2	196-161	1060-973	345-316	13	1.5	3.5	0.83
	380/60/3	2	270/222	450/350	350/300	2	196/161	1060/973	345/316	7/6	1.5	3.5	0.83
	460/60/3	1	375	500	450	2	162-133	878-774	285-252	13	1.5	3.0	0.83
	460/60/3	2	224/185	350/300	300/225	2	162/133	878/774	285/252	7/6	1.5	3.0	0.83
	575/60/3	1	301	400	350	2	130-106	705-631	229-205	13	1.5	2.5	0.83
	575/60/3	2	180/148	300/250	225/175	2	130/106	705/631	229/205	7/6	1.5	2.5	0.83
	400/50/3	1	433	600	500	2	189-160	1089-896	354-291	13	0.9	2.8	0.83
	400/50/3	2	256/217	400/350	350/300	2	189/160	1089/896	354/291	7/6	0.9	2.8	0.83



# Installation - Electrical

**Table 18 Unit Electrical Data for High Efficiency at Std. Ambient Operation**

Unit Size	Rated Voltage	Unit Wiring				Motor Data							
		# of Power Conns (1)	MCA (3) Ckt1/Ckt2	Max. Fuse, HACR Breaker or MOP (11) Ckt1/Ckt2	Rec. Time Delay or RDE (4) Ckt1/Ckt 2	Compressor (Each)			Fans (Each)				
						Qty	RLA (5) Ckt1/Ckt2	XLRA (8) Ckt1/Ckt2	YLRA (8) Ckt1/Ckt2	Qty. Ckt1/Ckt2	kW	FLA	Control VA (7)
<b>RTAC 200</b>	200/60/3	1	931	1200	1200	2	373-373	2156-2156	701-701	14	1.5	6.5	0.83
	200/60/3	2	512/512	800/800	700/700	2	373/373	2156/2156	701/701	7/7	1.5	6.5	0.83
	230/60/3	1	820	1000	1000	2	324-324	1756-1756	571-571	14	1.5	6.5	0.83
	230/60/3	2	451/451	700/700	600/600	2	324/324	1756/1756	571/571	7/7	1.5	6.5	0.83
	380/60/3	1	490	600	600	2	196-196	1060-1060	345-345	14	1.5	3.5	0.83
	380/60/3	2	270/270	450/450	350/350	2	196/196	1060/1060	345/345	7/7	1.5	3.5	0.83
	460/60/3	1	407	500	450	2	162-162	878-878	285-285	14	1.5	3.0	0.83
	460/60/3	2	224/224	350/350	300/300	2	162/162	878/878	285/285	7/7	1.5	3.0	0.83
	575/60/3	1	328	450	400	2	130-130	705-705	229-229	14	1.5	2.5	0.83
	575/60/3	2	180/180	300/300	225/225	2	130/130	705/705	229/229	7/7	1.5	2.5	0.83
400/50/3	1	464	600	600	2	189-189	1089-1089	354-354	14	0.9	2.8	0.83	
400/50/3	2	256/256	400/400	350/350	2	189/189	1089/1089	354/354	7/7	0.9	2.8	0.83	
<b>RTAC 225</b>	200/60/3	1	1023	1200	1200	2	447-373	2525-2156	821-701	14	1.5	6.5	0.83
	200/60/3	2	611/506	1000/800	800/600	2	447/373	2525/2156	821/701	8/6	1.5	6.5	0.83
	230/60/3	1	900	1200	1000	2	388-224	2126-1756	691-571	14	1.5	6.5	0.83
	230/60/3	2	537/544	800/700	700/600	2	388/324	2126/1756	691/571	8/6	1.5	6.5	0.83
	380/60/3	1	539	700	600	2	235-196	1306-1060	424-345	14	1.5	3.5	0.83
	380/60/3	2	322/266	500/450	400/350	2	235/196	1306/1060	424/345	8/6	1.5	3.5	0.83
	460/60/3	1	447	600	500	2	194-162	1065-878	346-285	14	1.5	3.0	0.83
	460/60/3	2	267/221	450/350	350/300	2	194/162	1065/878	346/285	8/6	1.5	3.0	0.83
	575/60/3	1	359	500	400	2	155-130	853-705	277-229	14	1.5	2.5	0.83
	575/60/3	2	214/178	350/300	300/225	2	155/130	853/705	277/229	8/6	1.5	2.5	0.83
<b>RTAC 250</b>	200/60/3	1	1110	1200	1200	2	447-447	2525-2525	821-821	16	1.5	6.5	0.83
	200/60/3	2	611/611	1000/1000	800/800	2	447/447	2525/2525	821/821	8/8	1.5	6.5	0.83
	230/60/3	1	977	1200	1200	2	388-388	2126-2126	691-691	16	1.5	6.5	0.83
	230/60/3	2	537/537	800/800	700/700	2	388/388	2126/2126	691/691	8/8	1.5	6.5	0.83
	380/60/3	1	585	800	700	2	235-235	1306-1306	424-424	16	1.5	3.5	0.83
	380/60/3	2	322/322	500/500	400/400	2	235/235	1306/1306	424/424	8/8	1.5	3.5	0.83
	460/60/3	1	485	600	600	2	194-194	1065-1065	346-346	16	1.5	3.0	0.83
	460/60/3	2	267/267	450/450	350/350	2	194/194	1065/1065	346/346	8/8	1.5	3.0	0.83
	575/60/3	1	389	500	450	2	155-155	853-853	277-277	7/4	1.5	2.5	0.83
	575/60/3	2	214/214	350/350	300/300	2	155/155	853/853	277/277	8/8	1.5	2.5	0.83
400/50/3	1	546	700	600	3	132-132-189	796-796-1089	259-259-354	16	0.9	2.8	1.2	
400/50/3	2	325/254	450/400	400/350	3	132/132/189	796/796/1089	259/259/354	10/6	0.9	2.8	1.2	
<b>RTAC 275</b>	200/60/3	1	NA										
	200/60/3	2	765/506	1000/800	1000/600	3	305/305/373	1845/1845/2156	600/600/701	12/6	1.5	6.5	1.2
	230/60/3	1	NA										
	230/60/3	2	675/444	800/700	800/600	3	265/265/324	1556/1556/1756	506/506/571	12/6	1.5	6.5	1.2
	380/60/3	1	NA										
	380/60/3	2	405/266	500/450	450/350	3	161/161/196	973/973/1060	316/316/345	12/6	1.5	3.5	1.2
	460/60/3	1	523	600	600	3	133-133-162	774-774-878	252-252-285	18	1.5	3.0	1.2
	460/60/3	2	336/221	450/350	400/300	3	133/133/162	774-774/878	252/252/285	12/6	1.5	3.0	1.2
	575/60/3	1	420	500	450	3	106-106-130	631-631-705	205-205-229	18	1.5	2.5	1.2
	575/60/3	2	269/178	350/300	300/225	3	106/106/130	631/631/705	205/205/229	12/6	1.5	2.5	1.2
400/50/3	1	607	700	700	3	160-160-189	896-896-1089	291-291-354	18	0.9	2.8	1.2	
400/50/3	2	394/254	500/400	450/350	3	160/160/189	896/896/1089	291/291/254	12/6	0.9	2.8	1.2	



# Installation - Electrical

**Table 18 Unit Electrical Data for High Efficiency at Std. Ambient Operation**

Unit Size	Rated Voltage	Unit Wiring				Motor Data								
		# of Power Conns (1)	MCA (3) Ckt1/Ckt2	Max. Fuse, HACR Breaker or MOP (11) Ckt1/Ckt2	Rec. Time Delay or RDE (4) Ckt1/Ckt 2	Compressor (Each)				Fans (Each)				
						Qty	RLA (5) Ckt1/Ckt2	XLRA (8) Ckt1/Ckt2	YLRA (8) Ckt1/Ckt2	Qty. Ckt1/Ckt2	kW	FLA	Control VA (7)	
<b>RTAC 300</b>	200/60/3	1	NA											
	200/60/3	2	931/506	1200/800	1200/600	3	373/373/373	2156/2156/2156	701/701/701	14/6	1.5	6.5	1.2	
	230/60/3	1	NA											
	230/60/3	2	820/444	1000/700	1000/600	3	324/324/324	1756/1756/1756	571/571/571	14/6	1.5	6.5	1.2	
	380/60/3	1	NA											
	380/60/3	2	490/266	600/450	600/350	3	196/196/196	1060/1060/1060	345/345/345	14/6	1.5	3.5	1.2	
	460/60/3	1	587	700	700	3	162-162 - 162	878-878-878	285-285-285	20	1.5	3.0	1.2	
	460/60/3	2	407/221	500/350	450/300	3	162/162/162	878/878/878	285/285/285	14/6	1.5	3.0	1.2	
	575/60/3	1	473	500	500	3	130-130-130	705-705-705	229-229-229	20	1.5	2.5	1.2	
	575/60/3	2	328/178	450/300	400/225	3	130/130/130	705/705/705	229/229/229	14/6	1.5	2.5	1.2	
<b>RTAC 350</b>	400/50/3	1	671	800	800	3	189-189-189	1089-1089-1089	354-354-354	20	0.9	2.8	1.2	
	400/50/3	2	465/254	600/400	600/350	3	189/189/189	1089/1089/1089	354/354/354	14/6	0.9	2.8	1.2	
	200/60/3	1	NA											
	200/60/3	2	765/765	1000/1000	1000/1000	4	305/305/305/305	1845/1845/1845/1845	600/600/600/600	12/12	1.5	6.5	1.2	
	230/60/3	1	NA											
	230/60/3	2	675/675	800/800	800/800	4	265/265/265/265	1556/1556/1556/1556	506/506/506/506	12/12	1.5	6.5	1.2	
	380/60/3	1	NA											
	380/60/3	2	405/405	500/500	450/450	4	161/161/161/161	973/973/973/973	316/316/316/316	12/12	1.5	3.5	1.2	
	460/60/3	1	638	700	700	4	133-133-133-133	774-774-774-774	252-252-252-252	24	1.5	3.0	1.2	
	460/60/3	2	336/336	450/450	400/400	4	133/133/133/133	774/774/774/774	252/252/252/252	12/12	1.5	3.0	1.2	
<b>RTAC 375</b>	575/60/3	1	511	600	600	4	106-106-106-106	631-631-631-631	205-205-205-205	24	1.5	2.5	1.2	
	575/60/3	2	269/269	350/350	300/300	4	106/106/106/106	631/631/631/631	205/205/205/205	12/12	1.5	2.5	1.2	
	400/50/3	1	748	800	800	4	160-160-160-160	896-896-896-896	291-291-291-291	24	0.9	2.8	1.59	
	400/50/3	2	394/394	500/500	450/450	4	160/160/160/160	896/896/896/896	291/291/291/291	12/12	0.9	2.8	1.59	
	400/50/3	1	819	1000	1000	4	189-189-160-160	1089-1089-896-896	354-354-291-291	26	0.9	2.8	1.59	
	400/50/3	2	465/394	600/500	600/450	4	189/189/160/160	1089/1089/896/896	254/254/291/291	14/12	0.9	2.8	1.59	



# Installation - Electrical

**Table 18 Unit Electrical Data for High Efficiency at Std. Ambient Operation**

Unit Size	Rated Voltage	Unit Wiring				Motor Data								
		# of Power Conns (1)	MCA (3) Ckt1/Ckt2	Max. Fuse, HACR Breaker or MOP (11) Ckt1/Ckt2	Rec. Time Delay or RDE (4) Ckt1/Ckt 2	Compressor (Each)				Fans (Each)				
						Qty	RLA (5) Ckt1/Ckt2	XLRA (8) Ckt1/Ckt2	YLRA (8) Ckt1/Ckt2	Qty. Ckt1/Ckt2	kW	FLA	Control VA (7)	
RTAC 400	200/60/3	1	NA											
	200/60/3	2	931/931	1200/1200	1200/1200	4	373/373/373/373	2156/2156/2156/2156	701/701/701/701	14/14	1.5	6.5	1.59	
	230/60/3	1	NA											
	230/60/3	2	820/820	1000/1000	1000/1000	4	324/324/324/324	1756/1756/1756/1756	571/571/571/571	14/14	1.5	6.5	1.59	
	380/60/3	1	NA											
	380/60/3	2	490/490	600/600	600/600	4	196/196/196/196	1060/1060/1060/1060	345/345/345/345	14/14	1.5	3.5	1.59	
	460/60/3	1	773	800	800	4	162-162-162-162	878-878-878-878	285-285-285-285	28	1.5	3.0	1.59	
	460/60/3	2	407/407	500/500	450/450	4	162/162/162/162	878/878/878/878	285/285/285/285	14/14	1.5	3.0	1.59	
	575/60/3	1	623	700	700	4	130-130-130-130	705-705-705-705	229-229-229-229	28	1.5	2.5	1.59	
	575/60/3	2	328/328	450/450	400/400	4	130/130/130/130	705/705/705/705	229/229/229/229	14/14	1.5	2.5	1.59	
	400/50/3	1	882	1000	1000	4	189-189-189-189	1089-1089-1089-1089	354-354-354-354	28	0.9	2.8	1.59	
	400/50/3	2	465/465	600/600	600/600	4	189/189/189/189	1089/1089/1089/1089	354/354/354/354	14/14	0.9	2.8	1.59	

**Notes:**

- As standard, 140-250 ton (60 Hz) units and 140-200 ton (50Hz) units have a single point power connection. Optional dual point power connections are available. As standard, 275-500 ton (60Hz) units and 250-400 ton (50Hz) units have dual point power connections. Optional single point power connections are available on 380V, 460V 575V/50 Hz and 400V/50 Hz units.
- Max Fuse or HACR type breaker = 225 percent of the largest compressor RLA plus 100 percent of the second compressor RLA, plus the sum of the condenser fan FLA per NEC 440-22. (Use FLA per circuit, NOT FLA for the entire unit).
- MCA - Minimum Circuit Ampacity - 125 percent of largest compressor RLA plus 100 percent of the second compressor RLA plus the sum of the condenser fans FLAs per NEC 440-33.
- RECOMMENDED TIME DELAY OR DUAL ELEMENT (RDE) FUSE SIZE: 150 percent of the largest compressor RLA plus 100 percent of the second compressor RLA and the sum of the condenser fan FLAs.
- RLA - Rated Load Amps - rated in accordance with UL Standard 1995.
- Local codes may take precedence.
- Control VA includes operational controls only. Does not include evaporator heaters.
- XLRA - Locked Rotor Amps - based on full winding (x-line) start units. YLRA for wye-delta starters is ~1/3 of LRA of x-line units.
- Voltage Utilization Range:

Rated Voltage	200/60/3	230/60/3	380/60/3	460/60/3	575/60/3	400/50/3
Use Range	180-220	208-254	342-418	414-506	516-633	360-440
- A separate 115/60/1, 20 amp or 220/50/1, 15 amp customer provided power connection is required to power the evaporator heaters (1640 watts).
- If factory circuit breakers are supplied with the chiller, then these values represent Maximum Overcurrent Protection (MOP).



# Installation - Electrical

**Table 19 Unit Electrical Data for High Efficiency at High Ambient Operation**

Unit Size	Rated Voltage	Unit Wiring				Motor Data							
		# of Power Conns (1)	MCA (3) Ckt1/Ckt2	Max. Fuse, HACR Breaker or MOP (11) Ckt1/Ckt2	Rec. Time Delay or RDE (4) Ckt1/Ckt 2	Compressor (Each)				Fans (Each)			
						Qty	RLA (5) Ckt1/Ckt2	XLRA (8) Ckt1/Ckt2	YLRA (8) Ckt1/Ckt2	Qty. Ckt1/Ckt2	kW	FLA	Control VA (7)
<b>RTAC 140</b>	200/60/3	1	673	800	800	2	270-270	1498-1498	487-487	10	1.5	6.5	0.83
	200/60/3	2	370/370	600/600	450/450	2	270/270	1498/1498	487/487	5/5	1.5	6.5	0.83
	230/60/3	1	594	700	700	2	235-235	1314-1314	427-427	10	1.5	6.5	0.83
	230/60/3	2	327/327	500/500	400/400	2	235/235	1314/1314	427/427	5/5	1.5	6.5	0.83
	380/60/3	1	355	400	400	2	142-142	801-801	260-260	10	1.5	3.5	0.83
	380/60/3	2	195/195	300/300	250/250	2	142/142	801/801	260/260	5/5	1.5	3.5	0.83
	460/60/3	1	296	400	350	2	118-118	652-652	212-212	10	1.5	3.0	0.83
	460/60/3	2	163/163	250/250	200/200	2	118/118	652/652	212/212	5/5	1.5	3.0	0.83
	575/60/3	1	237	300	300	2	94-94	520-520	172-172	10	1.5	2.5	0.83
	575/60/3	2	130/130	200/200	175/175	2	94/94	520/520	172/172	5/5	1.5	2.5	0.83
400/50/3	1	339	450	400	2	138-138	774-774	259-259	10	0.9	2.8	0.83	
400/50/3	2	187/187	300/300	225/225	2	138/138	774/774	259/259	5/5	0.9	2.8	0.83	
<b>RTAC 155</b>	200/60/3	1	742	1000	1000	2	320-270	1845-1498	600-487	11	1.5	6.5	0.83
	200/60/3	2	439/370	700/600	600/450	2	320/270	1845/1498	600/487	6/5	1.5	6.5	0.83
	230/60/3	1	654	800	800	2	278-235	1556-1314	506-427	11	1.5	6.5	0.83
	230/60/3	2	387/327	600/500	500/400	2	278/235	1556/1314	506/427	6/5	1.5	6.5	0.83
	380/60/3	1	391	500	450	2	168-142	973-801	316-260	11	1.5	3.5	0.83
	380/60/3	2	231/195	350/300	300/250	2	168/142	973/801	316/260	6/5	1.5	3.5	0.83
	460/60/3	1	325	450	400	2	139-118	774-652	252-212	11	1.5	3.0	0.83
	460/60/3	2	192/163	300/250	225/200	2	139/118	774/652	252/212	6/5	1.5	3.0	0.83
	575/60/3	1	261	350	300	2	111-94	631-528	205-172	11	1.5	2.5	0.83
	575/60/3	2	154/130	250/200	200/175	2	111/94	631/528	205/172	6/5	1.5	2.5	0.83
400/50/3	1	379	500	450	2	168-138	896-796	291-259	11	0.9	2.8	0.83	
400/50/3	2	227/187	350/300	300/225	2	168/138	896/796	291/259	6/5	0.9	2.8	0.83	
<b>RTAC 170</b>	200/60/3	1	798	1000	1000	2	320-320	1845-1845	600-600	12	1.5	6.5	0.83
	200/60/3	2	439/439	700/700	600/600	2	320/320	1845/1845	600/600	6/6	1.5	6.5	0.83
	230/60/3	1	704	800	800	2	278-278	1556-1556	506-506	12	1.5	6.5	0.83
	230/60/3	2	387/387	600/600	500/500	2	278/278	1556/1556	506/506	6/6	1.5	6.5	0.83
	380/60/3	1	420	500	500	2	168-168	973-973	316-316	12	1.5	3.5	0.83
	380/60/3	2	231/231	350/350	300/300	2	168/168	973/973	316/316	6/6	1.5	3.5	0.83
	460/60/3	1	349	450	400	2	139-139	774-774	252-252	12	1.5	3.0	0.83
	460/60/3	2	192/192	300/300	225/225	2	139/139	774/774	252/252	6/6	1.5	3.0	0.83
	575/60/3	1	280	350	350	2	111-111	631-631	205-205	12	1.5	2.5	0.83
	575/60/3	2	154/154	250/250	200/200	2	111/111	631/631	205/205	6/6	1.5	2.5	0.83
400/50/3	1	412	500	500	2	168-168	896-896	291-291	12	0.9	2.8	0.83	
400/50/3	2	227/227	350/350	300/300	2	168/168	896/896	291/291	6/6	0.9	2.8	0.83	
<b>RTAC 185</b>	200/60/3	1	887	1200	1000	2	386-320	2156-1845	701-600	13	1.5	6.5	0.83
	200/60/3	2	528/439	800/700	700/600	2	386/320	2156/1845	701/600	7/6	1.5	6.5	0.83
	230/60/3	1	783	1000	1000	2	336-278	1756-1556	571-506	13	1.5	6.5	0.83
	230/60/3	2	466/387	800/600	600/500	2	336/278	1756/1556	571/506	7/6	1.5	6.5	0.83
	380/60/3	1	467	600	600	2	203-168	1060-973	345-316	13	1.5	3.5	0.83
	380/60/3	2	278/231	450/350	350/300	2	203/168	1060/973	345/316	7/6	1.5	3.5	0.83
	460/60/3	1	388	500	450	2	168-139	878-774	285-252	13	1.5	3.0	0.83
	460/60/3	2	231/192	350/300	300/225	2	168/139	878/774	285/252	7/6	1.5	3.0	0.83
	575/60/3	1	311	450	350	2	134-111	705-631	229-205	13	1.5	2.5	0.83
	575/60/3	2	185/154	300/250	225/200	2	134/111	705/631	229/205	7/6	1.5	2.5	0.83
400/50/3	1	445	600	500	2	198-168	1089-896	354-291	13	0.9	2.8	0.83	
400/50/3	2	267/227	450/350	350/300	2	198/168	1089/896	354/291	7/6	0.9	2.8	0.83	



# Installation - Electrical

**Table 19 Unit Electrical Data for High Efficiency at High Ambient Operation**

Unit Size	Rated Voltage	Unit Wiring				Motor Data							
		# of Power Conns (1)	MCA (3) Ckt1/Ckt2	Max. Fuse, HACR Breaker or MOP (11) Ckt1/Ckt2	Rec. Time Delay or RDE (4) Ckt1/Ckt 2	Compressor (Each)				Fans (Each)			
						Qty	RLA (5) Ckt1/Ckt2	XLRA (8) Ckt1/Ckt2	YLRA (8) Ckt1/Ckt2	Qty, Ckt1/Ckt2	kW	FLA	Control VA (7)
RTAC 200	200/60/3	1	960	1200	1200	2	386-386	2156-2156	701-701	14	1.5	6.5	0.83
	200/60/3	2	528/528	800/800	700/700	2	386/386	2156/2156	701/701	7/7	1.5	6.5	0.83
	230/60/3	1	847	1000	1000	2	336-336	1756-1756	571-571	14	1.5	6.5	0.83
	230/60/3	2	466/466	800/800	600/600	2	336/336	1756/1756	571/571	7/7	1.5	6.5	0.83
	380/60/3	1	506	700	600	2	203-203	1060-1060	345-345	14	1.5	3.5	0.83
	380/60/3	2	278/278	450/450	350/350	2	203/203	1060/1060	345/345	7/7	1.5	3.5	0.83
	460/60/3	1	420	500	500	2	168-168	878-878	285-285	14	1.5	3.0	0.83
	460/60/3	2	231/231	350/350	300/300	2	168/168	878/878	285/285	7/7	1.5	3.0	0.83
	575/60/3	1	337	450	400	2	134-134	705-705	229-229	14	1.5	2.5	0.83
	575/60/3	2	185/185	300/300	225/225	2	134/134	705/705	229/229	7/7	1.5	2.5	0.83
	400/50/3	1	485	600	600	2	198-198	1089-1089	354-354	14	0.9	2.8	0.83
400/50/3	2	267/267	450/450	350/350	2	198/198	1089/1089	354/354	7/7	0.9	2.8	0.83	
RTAC 225	200/60/3	1	1051	1200	1200	2	459-358	2525-2156	821-701	14	1.5	6.5	0.83
	200/60/3	2	626/522	1000/800	800/700	2	459/358	2525/2156	821/701	8/6	1.5	6.5	0.83
	230/60/3	1	926	1200	1200	2	399-336	2126-1756	691-571	14	1.5	6.5	0.83
	230/60/3	2	551/459	800/700	700/600	2	399/336	2126/1756	691/571	8/6	1.5	6.5	0.83
	380/60/3	1	555	700	700	2	242-203	1306-1060	424-345	14	1.5	3.5	0.83
	380/60/3	2	331/275	500/450	400/350	2	242/203	1306/1060	424/345	8/6	1.5	3.5	0.83
	460/60/3	1	460	600	600	2	200-168	1065-878	346-285	14	1.5	3.0	0.83
	460/60/3	2	274/228	450/350	350/300	2	200/168	1065/878	346/285	8/6	1.5	3.0	0.83
	575/60/3	1	369	500	450	2	160-134	853-705	277-229	14	1.5	2.5	0.83
	575/60/3	2	220/183	350/300	300/225	2	160/134	853/705	277/229	8/6	1.5	2.5	0.83
RTAC 250	200/60/3	1	1137	1200	1200	2	459-459	2525-2525	821-821	16	1.5	6.5	0.83
	200/60/3	2	626/626	1000/1000	800/800	2	459/459	2525/2525	821/821	8/8	1.5	6.5	0.83
	230/60/3	1	1002	1200	1200	2	399-399	2126-2126	691-691	16	1.5	6.5	0.83
	230/60/3	2	551/551	800/800	700/700	2	399/399	2126/2126	691/691	8/8	1.5	6.5	0.83
	380/60/3	1	601	800	700	2	242-242	1306-1306	424-424	16	1.5	3.5	0.83
	380/60/3	2	331/331	500/500	400/400	2	242/242	1306/1306	424/424	8/8	1.5	3.5	0.83
	460/60/3	1	498	600	600	2	200-200	1065-1065	346-346	16	1.5	3.0	0.83
	460/60/3	2	274/274	450/450	350/350	2	200/200	1065/1065	346/346	8/8	1.5	3.0	0.83
	575/60/3	1	400	500	450	2	160-160	853-853	277-277	16	1.5	2.5	0.83
	575/60/3	2	220/220	350/350	300/300	2	160/160	853/853	277/277	8/8	1.5	2.5	0.83
	400/50/3	1	569	700	700	3	138-138-198	796-796-1089	259-259-354	16	0.9	2.8	1.2
	400/50/3	2	339/265	450/450	400/350	3	138/138/198	796/796/1089	259/259/354	10/6	0.9	2.8	1.2
RTAC 275	200/60/3	1	NA										
	200/60/3	2	798/522	1000/800	1000/700	3	320/320/386	1845/1845/2156	600/600/701	12/6	1.5	6.5	1.2
	230/60/3	1	NA										
	230/60/3	2	704/459	800/700	800/600	3	278/278/336	1556/1556/1756	506/506/571	12/6	1.5	6.5	1.2
	380/60/3	1	NA										
	380/60/3	2	420/275	500/450	500/350	3	168/168/203	973/973/1060	316/316/345	12/6	1.5	3.5	1.2
	460/60/3	1	542	700	600	3	139-139-168	774-774-878	252-252-285	18	1.5	3.0	1.2
	460/60/3	2	349/228	450/350	400/300	3	139/139/168	774/774/878	252/252/285	12/6	1.5	3.0	1.2
	575/60/3	1	435	500	500	3	111-111-134	631-631-705	205-205-229	18	1.5	2.5	1.2
	575/60/3	2	280/183	350/300	350/225	3	111/111/134	631/631/705	205/205/229	12/6	1.5	2.5	1.2
	400/50/3	1	634	800	700	3	168-168-168	896-896-1089	291-291-354	18	0.9	2.8	1.2
	400/50/3	2	412/265	500/450	500/350	3	168/168/168	896/896/1089	291/291/254	12/6	0.9	2.8	1.2



# Installation - Electrical

**Table 19 Unit Electrical Data for High Efficiency at High Ambient Operation**

Unit Size	Rated Voltage	Unit Wiring				Motor Data								
		# of Power Conns (1)	MCA (3) Ckt1/Ckt2	Max. Fuse, HACR Breaker or MOP (11) Ckt1/Ckt2	Rec. Time Delay or RDE (4) Ckt1/Ckt 2	Compressor (Each)				Fans (Each)				
						Qty	RLA (5) Ckt1/Ckt2	XLRA (8) Ckt1/Ckt2	YLRA (8) Ckt1/Ckt2	Qty. Ckt1/Ckt2	kW	FLA	Control VA (7)	
<b>RTAC 300</b>	200/60/3	1	NA											
	200/60/3	2	960522	1200/800	1200/700	3	386/386/386	2156/2156/2156	701/701/701	14/6	1.5	6.5	1.2	
	230/60/3	1	NA											
	230/60/3	2	847/459	1000/700	1000/600	3	336/336/336	1756/1756/1756	571/571/571	14/6	1.5	6.5	1.2	
	380/60/3	1	NA											
	380/60/3	2	506/275	700/450	600/350	3	203/203/203	1060/1060/1060	345/345/345	14/6	1.5	3.5	1.2	
	460/60/3	1	606	700	700	3	168-168-168	878-878-878	285-285-285	20	1.5	3.0	1.2	
	460/60/3	2	420/228	500/350	500/300	3	168/168/168	878/878/878	285/285/285	14/6	1.5	3.0	1.2	
	575/60/3	1	486	600	600	3	134-134-134	705-705-705	229-229-229	20	1.5	2.5	1.2	
	575/60/3	2	337/183	450/300	400/225	3	134/134/134	705/705/705	229/229/229	14/6	1.5	2.5	1.2	
400/50/3	1	700	800	800	3	198-198-198	1089-1089-1089	354-354-354	20	0.9	2.8	1.2		
400/50/3	2	485/265	600/450	600/350	3	198/198/198	1089/1089/1089	354/354/354	14/6	0.9	2.8	1.2		
<b>RTAC 350</b>	200/60/3	1	NA											
	200/60/3	2	798/798	1000/1000	1000/1000	4	320/320/320/320	1845/1845/1845/1845	600/600/600/600	12/12	1.5	6.5	1.2	
	230/60/3	1	NA											
	230/60/3	2	704/704	800/800	800/800	4	278/278/278/278	1556/1556/1556/1556	506/506/506/506	12/12	1.5	6.5	1.2	
	380/60/3	1	NA											
	380/60/3	2	420/420	500/500	500/500	4	168/168/168/168	973/973/973/973	316/316/316/316	12/12	1.5	3.5	1.2	
	460/60/3	1	663	700	700	4	139-139-139-139	774-774-774-774	252-252-252-252	24	1.5	3.0	1.2	
	460/60/3	2	349/349	450/450	400/400	4	139/139/139/139	774/774/774/774	252/252/252/252	12/12	1.5	3.0	1.2	
	575/60/3	1	532	600	600	4	111-111-111-111	631-631-631-631	205-205-205-205	24	1.5	2.5	1.2	
	575/60/3	2	280/280	350/350	350/350	4	111/111/111/111	631/631/631/631	205/205/205/205	12/12	1.5	2.5	1.2	
400/50/3	1	782	800	800	4	168-168-168-168	896-896-896-896	291-291-291-291	24	0.9	2.8	1.59		
400/50/3	2	412/412	500/500	500/500	4	168/168/168/168	896/896/896/896	291/291/291/291	12/12	0.9	2.8	1.59		
<b>RTAC 375</b>	400/50/3	1	855	1000	1000	4	198-198-168-168	1089-1089-896-896	354-354-291-291	26	0.9	2.8	1.59	
	400/50/3	2	485/412	600/500	600/500	4	198/198/168/168	1089/1089/896/896	254/254/291/291	14/12	0.9	2.8	1.59	



# Installation - Electrical

**Table 19 Unit Electrical Data for High Efficiency at High Ambient Operation**

Unit Size	Rated Voltage	Unit Wiring				Motor Data								
		# of Power Conns (1)	MCA (3) Ckt1/Ckt2	Max. Fuse, HACR Breaker or MOP (11) Ckt1/Ckt2	Rec. Time Delay or RDE (4) Ckt1/Ckt 2	Compressor (Each)				Fans (Each)				
						Qty	RLA (5) Ckt1/Ckt2	XLRA (8) Ckt1/Ckt2	YLRA (8) Ckt1/Ckt2	Qty. Ckt1/Ckt2	kW	FLA	Control VA (7)	
RTAC 400	200/60/3	1	NA											
	200/60/3	2	960/960	1200/1200	1200/1200	4	386/386/386/386	2156/2156/2156/2156	701/701/701/701	14/14	1.5	6.5	1.59	
	230/60/3	1	NA											
	230/60/3	2	847/847	1000/1000	1000/1000	4	336/336/336/336	1756/1756/1756/1756	571/571/571/571	14/14	1.5	6.5	1.59	
	380/60/3	1	NA											
	380/60/3	2	505/506	700/700	600/600	4	203/203/203/203	1060/1060/1060/1060	345/345/345/345	14/14	1.5	3.5	1.59	
	460/60/3	1	798	800	800	4	168-168-168-168	878-878-878-878	285-285-285-285	28	1.5	3.0	1.59	
	460/60/3	2	420/420	500/500	500/500	4	168/168/168/168	878/878/878/878	285/285/285/285	14/14	1.5	3.0	1.59	
	575/60/3	1	640	700	700	4	134-134-134-134	705-705-705-705	229-229-229-229	28	1.5	2.5	1.59	
	575/60/3	2	337/337	450/450	400/400	4	134/134/134/134	705/705/705/705	229/229/229/229	14/14	1.5	2.5	1.59	
400/50/3	1	920	1000	1000	4	198-198-198-198	1089-1089-1089-1089	354-354-354-354	28	0.9	2.8	1.59		
400/50/3	2	485/485	600/600	600/600	4	198/198/198/198	1089/1089/1089/1089	354/354/354/354	14/14	0.9	2.8	1.59		

**Notes:**

- As standard, 140-250 ton (60 Hz) units and 140-200 ton (50Hz) units have a single point power connection. Optional dual point power connections are available. As standard, 275-500 ton (60Hz) units and 250-400 ton (50Hz) units have dual point power connections. Optional single point power connections are available on 380V, 460V 575V/50 Hz and 400V/50 Hz units.
  - Max Fuse or HACR type breaker = 225 percent of the largest compressor RLA plus 100 percent of the second compressor RLA, plus the sum of the condenser fan FLA per NEC 440-22. (Use FLA per circuit, NOT FLA for the entire unit).
  - MCA - Minimum Circuit Ampacity - 125 percent of largest compressor RLA plus 100 percent of the second compressor RLA plus the sum of the condenser fans FLAs per NEC 440-33.
  - RECOMMENDED TIME DELAY OR DUAL ELEMENT (RDE) FUSE SIZE: 150 percent of the largest compressor RLA plus 100 percent of the second compressor RLA and the sum of the condenser fan FLAs.
  - RLA - Rated Load Amps - rated in accordance with UL Standard 1995.
  - Local codes may take precedence.
  - Control VA includes operational controls only. Does not include evaporator heaters.
  - XLRA - Locked Rotor Amps - based on full winding (x-line) start units. YLRA for wye-delta starters is ~1/3 of LRA of x-line units.
- Voltage Utilization Range:
- |               |          |          |          |          |          |          |
|---------------|----------|----------|----------|----------|----------|----------|
| Rated Voltage | 200/60/3 | 230/60/3 | 380/60/3 | 460/60/3 | 575/60/3 | 400/50/3 |
| Use Range     | 180-220  | 208-254  | 342-418  | 414-506  | 516-633  | 360-440  |
- A separate 115/60/1, 20 amp or 220/50/1, 15 amp customer provided power connection is required to power the evaporator heaters (1640 watts).
  - If factory circuit breakers are supplied with the chiller, then these values represent Maximum Overcurrent Protection (MOP).



# Installation - Electrical

---

## Installer-Supplied Components

Customer wiring interface connections are shown in the electrical schematics and connection diagrams that are shipped with the unit. The installer must provide the following components if not ordered with the unit:

- Power supply wiring (in conduit) for all field-wired connections.
- All control (interconnecting) wiring (in conduit) for field supplied devices.
- Fused-disconnect switches or circuit breakers.
- Power factor correction capacitors. (optional)

## Power Supply Wiring

All power supply wiring must be sized and selected accordingly by the project engineer in accordance with NEC Table 310-16.

## **⚠ WARNING**

### **Hazardous Voltage w/Capacitors!**

**Disconnect all electric power, including remote disconnects before servicing. Follow proper lockout/tagout procedures to ensure the power cannot be inadvertently energized. For variable frequency drives or other energy storing components provided by Trane or others, refer to the appropriate manufacturer's literature for allowable waiting periods for discharge of capacitors. Verify with an appropriate voltmeter that all capacitors have discharged. Failure to disconnect power and discharge capacitors before servicing could result in death or serious injury.**

**Note: For additional information regarding the safe discharge of capacitors, see PROD-SVB06A-EN or PROD-SVB06A-FR**

All wiring must comply with local codes and the National Electrical Code. The installing (or electrical) contractor must provide and install the system interconnecting wiring, as well as the power supply wiring. It must be properly sized and equipped with the appropriate fused disconnect switches.

The type and installation location(s) of the fused disconnects must comply with all applicable codes.

## **CAUTION**

### **Use Copper Conductors Only!**

**Unit terminals are not designed to accept other types of conductors. Failure to use copper conductors may result in equipment damage.**

Cut holes into the sides of the control panel for the appropriately-sized power wiring conduits. The wiring is passed through these conduits and connected to the terminal blocks, optional unit-mounted disconnects, or HACR type breakers. Refer to [Figure 31](#).

To provide proper phasing of 3-phase input, make connections as shown in field wiring diagrams and as stated on the WARNING label in the starter panel. For additional information on proper phasing, refer to "Unit Voltage Phasing." Proper equipment ground must be provided to each ground connection in the panel (one for each customer-supplied conductor per phase).



## Installation - Electrical

115 volt field-provided connections (either control or power) are made through knockouts on the lower left side of the panel (Figure 31). Additional grounds may be required for each 115 volt power supply to the unit. Green lugs are provided for 115V customer wiring.



Figure 31 Starter Panel

### Control Power Supply

The unit is equipped with a control power transformer; it is not necessary to provide additional control power voltage to the unit.

All units are factory-connected for appropriate labeled voltages except for the 400V/50Hz units which need the control power transformer (1T1) reconnected as noted below.

*NOTE: Important! As shipped, a normal 400 volt unit control power transformer is wired on the 400 volt tap (H3). Reconnect the appropriate transformer wire lead 126A to the tap (H2) for 380V/50Hz power supply or lead 126A to the tap H4 for the 415V/50 Hz power supply. It is also necessary to adjust the "unit voltage" setting using TechView (Configuration-Custom Tab).*

### Heater Power Supply and Convenience Outlet (Packaged Units Only)

The evaporator shell is insulated from ambient air and protected from freezing temperatures by two thermostatically-controlled immersion heaters and two strip heaters. Whenever the water temperature drops to approximately 37°F (2.8°C), the thermostat energizes the heaters. The heaters will provide protection from ambient temperatures down to -20°F (-29°C).

It is required to provide an independent power source (115V 60Hz-20 amp, 220V 50Hz-15 amp), with a fused-disconnect. The heaters are factory-wired back to the unit control panel.



## Installation - Electrical

---

### CAUTION

#### Heat Tape!

**Control panel main processor does not check for loss of power to the heat tape nor does it verify thermostat operation. A qualified technician must verify power to the heat tape and confirm operation of the heat tape thermostat to avoid catastrophic damage to the evaporator.**

A convenience outlet is also optional, which shares the same power supply as the heaters on 140-250 ton units. Be aware that when the heater is operating, the convenience outlet amperage draw will be reduced accordingly.

*NOTE: The convenience outlet is optional. The heaters are required.*

### Interconnecting Wiring

#### Chilled Water Flow (Pump) Interlock

The Model RTAC Series R<sup>®</sup> chiller **requires** a field-supplied control voltage contact input through a flow proving switch 5S1 and an auxiliary contact 5K1 AUX. Connect the proving switch and auxiliary contact to 1TB5-8 and 1U11 J3-2. Refer to the field wiring for details. The auxiliary contact can be BAS signal, starter contactor auxiliary, or any signal which indicates the pump is running. A flow switch is still required and cannot be omitted.

#### Chilled Water Pump Control

An evaporator water pump output relay closes when the chiller is given a signal to go into the Auto mode of operation from any source. The contact is opened to turn off the pump in the event of most machine level diagnostics to prevent the build up of pump heat.

### CAUTION

#### Evaporator Damage!

**IMPORTANT: ALL unit chilled water pumps must be controlled by the Trane CH530 to avoid catastrophic damage to the evaporator due to freezing. Refer to RLC-PRB012-EN.**

The relay output from 1U10 is required to operate the Evaporator Water Pump (EWP) contactor. Contacts should be compatible with 115/240 VAC control circuit. The EWP relay operates in different modes depending on CH530 or Tracer commands, if available, or service pumpdown (See maintenance section). Normally, the EWP relay follows the AUTO mode of the chiller. Whenever the chiller has no diagnostics and is in the AUTO mode, regardless of where the auto command is coming from, the normally open relay is energized. When the chiller exits the AUTO mode, the relay is timed open for an adjustable (using TechView) 0 to 30 minutes. The non-AUTO modes in which the pump is stopped, include Reset (88), Stop (00), External Stop (100), Remote Display Stop (600), Stopped by Tracer (300), Low Ambient Run Inhibit (200), and Ice Building complete (101).

Regardless of whether the chiller is allowed to control the pump on a full-time basis, if the MP calls for a pump to start and water does not flow, the evaporator may be damaged catastrophically. It is the responsibility of the installing contractor and/or the customer to ensure that a pump will start when called upon by the chiller controls.



# Installation - Electrical

**Table 20 Pump Relay Operation**

Chiller Mode	Relay Operation
Auto	Instant close
Ice Building	Instant close
Tracer Override	Close
Stop	Timed Open
Ice Complete	Instant Open
Diagnostics	Instant Open

*NOTE: Exceptions are listed below.*

When going from Stop to Auto, the EWP relay is energized immediately. If evaporator water flow is not established in 4 minutes and 15 sec., the CH530 de-energizes the EWP relay and generates a non-latching diagnostic. If flow returns (e.g. someone else is controlling the pump), the diagnostic is cleared, the EWP is re-energized, and normal control resumed.

If evaporator water flow is lost once it had been established, the EWP relay remains energized and a non-latching diagnostic is generated. If flow returns, the diagnostic is cleared and the chiller returns to normal operation.

In general, when there is either a non-latching or latching diagnostic, the EWP relay is turned off as though there was a zero time delay. Exceptions (see above table) whereby the relay continues to be energized occur with:

A Low Chilled Water Temp. diagnostic (non-latching) (unless also accompanied by an Evap Leaving Water Temperature Sensor Diagnostic)

or

A starter contactor interrupt failure diagnostic, in which a compressor continues to draw current even after commanded to have shutdown

or

A Loss of Evaporator Water Flow diagnostic (non-latching) and the unit is in the AUTO mode, after initially having proven evaporator water flow.

### Alarm and Status Relay Outputs (Programmable Relays)

A programmable relay concept provides for enunciation of certain events or states of the chiller, selected from a list of likely needs, while only using four physical output relays, as shown in the field wiring diagram. The four relays are provided (generally with a Quad Relay Output LLID) as part of the Alarm Relay Output Option. The relay's contacts are isolated Form C (SPDT), suitable for use with 120 VAC circuits drawing up to 2.8 amps inductive, 7.2 amps resistive, or 1/3 HP and for 240 VAC circuits drawing up to 0.5 amp resistive.

The list of events/states that can be assigned to the programmable relays can be found in [Table 21](#). The relay will be energized when the event/state occurs.

**Table 21 Alarm and Status Relay Output Configuration Table**

	Description
Alarm - Latching	This output is true whenever there is any active diagnostic that requires a manual reset to clear, that affects either the Chiller, the Circuit, or any of the Compressors on a circuit. This classification does not include informational diagnostics.
Alarm - Auto Reset	This output is true whenever there is any active diagnostic that could automatically clear, that affects either the Chiller, the Circuit, or any of the Compressors on a circuit. This classification does not include informational diagnostics.
Alarm	This output is true whenever there is any diagnostic affecting any component, whether latching or automatically clearing. This classification does not include informational diagnostics



# Installation - Electrical

**Table 21 Alarm and Status Relay Output Configuration Table**

	Description
Alarm Ckt 1	This output is true whenever there is any diagnostic effecting Refrigerant Circuit 1, whether latching or automatically clearing, including diagnostics affecting the entire chiller. This classification does not include informational diagnostics.
Alarm Ckt 2	This output is true whenever there is any diagnostic affecting Refrigerant Circuit 2 whether latching or automatically clearing, including diagnostics effecting the entire chiller. This classification does not include informational diagnostics.
Chiller Limit Mode (with a 20 minute filter)	This output is true whenever the chiller has been running in one of the Unloading types of limit modes (Condenser, Evaporator, Current Limit or Phase Imbalance Limit) continuously for the last 20 minutes.
Circuit 1 Running	This output is true whenever any compressors are running (or commanded to be running) on Refrigerant Circuit 1, and false when no compressors are commanded to be running on that circuit.
Circuit 2 Running	This output is true whenever any compressors are running (or commanded to be running) on Refrigerant Circuit 2, and false when no compressors are commanded to be running on that circuit.
Chiller Running	This output is true whenever any compressors are running (or commanded to be running) on the chiller and false when no compressors are commanded to be running on the chiller.
Maximum Capacity (software 18.0 or later)	This output is true whenever the chiller has reached maximum capacity or had reached its maximum capacity and since that time has not fallen below 70% average current relative to the rated ARI current for the chiller. The output is false when the chiller falls below 70% average current and, since that time, had not reestablished maximum capacity.

### Relay Assignments Using TechView

CH530 Service Tool (TechView) is used to install the Alarm and Status Relay Option package and assign any of the above list of events or status to each of the four relays provided with the option. The relays to be programmed are referred to by the relay's terminal numbers on the LLID board 1U12.

The default assignments for the four available relays of the RTAC Alarm and Status Package Option are:

**Table 22 Default Assignments**

Relay	
Relay 1 Terminals J2 -12,11,10:	Alarm
Relay 2 Terminals J2 - 9,8,7:	Chiller Running
Relay 3 Terminals J2-6,5,4:	Maximum Capacity (software 18.0 or later)
Relay 4 Terminals J2-3,2,1:	Chiller Limit

If any of the Alarm/Status relays are used, provide electrical power, 115 VAC with fused-disconnect to the panel and wire through the appropriate relays (terminals on 1U12 (EUR=A4-5)). Provide wiring (switched hot, neutral, and ground connections) to the remote annunciation devices. Do not use power from the chiller's control panel transformer to power these remote devices. Refer to the field diagrams which are shipped with the unit.

### Low Voltage Wiring

The remote devices described below require low voltage wiring. All wiring to and from these remote input devices to the Control Panel must be made with shielded, twisted pair conductors. Be sure to ground the shielding only at the panel.

**To prevent control malfunctions, do not run low voltage wiring (<30 V) in conduit with conductors carrying more than 30 volts.**

### Emergency Stop

CH530 provides auxiliary control for a customer specified/installed latching trip out. When this customer-furnished remote contact 5K14 is provided, the chiller will run normally when the contact is closed. When the contact opens, the unit will trip on a manually resettable diagnostic. This condition requires manual reset at the chiller switch on the front of the control panel.

Connect low voltage leads to terminal strip locations on 1U4. Refer to the field diagrams that are shipped with the unit.



## Installation - Electrical

---

Silver or gold-plated contacts are recommended. These customer-furnished contacts must be compatible with 24 VDC, 12 mA resistive load.

### External Auto/Stop

If the unit requires the external Auto/Stop function, the installer must provide leads from the remote contacts 5K15 to the proper terminals of the LLID 1U4 on the control panel.

The chiller will run normally when the contacts are closed. When either contact opens, the compressor(s), if operating, will go to the RUN:UNLOAD operating mode and cycle off. Unit operation will be inhibited. Closure of the contacts will permit the unit to return to normal operation.

Field-supplied contacts for all low voltage connections must be compatible with dry circuit 24 VDC for a 12 mA resistive load. Refer to the field diagrams that are shipped with the unit.

### External Circuit Lockout – Circuit #1 and Circuit #2

CH530 provides auxiliary control of a customer specified or installed contact closure, for individual operation of either Circuit #1 or #2. If the contact is closed, the refrigerant circuit will not operate 1K15 and 1K16.

Upon contact opening, the refrigerant circuit will run normally. This feature is used to restrict total chiller operation, e.g. during emergency generator operations.

Connections to 1U5 are shown in the field diagrams that are shipped with the unit.

These customer-supplied contact closures must be compatible with 24 VDC, 12 mA resistive load. Silver or gold plated contacts are recommended.

### Ice Building Option

CH530 provides auxiliary control for a customer specified/installed contact closure for ice building if so configured and enabled. This output is known as the Ice Building Status Relay. The normally open contact will be closed when ice building is in progress and open when ice building has been normally terminated either through Ice Termination setpoint being reached or removal of the Ice Building command. This output is for use with the ice storage system equipment or controls (provided by others) to signal the system changes required as the chiller mode changes from “ice building” to “ice complete”. When contact 5K18 is provided, the chiller will run normally when the contact is open.

CH530 will accept either an isolated contact closure (External Ice Building command) or a Remote Communicated input (Tracer) to initiate and command the Ice Building mode.

CH530 also provides a “Front Panel Ice Termination Setpoint”, settable through TechView, and adjustable from 20 to 31°F (-6.7 to -0.5°C) in at least 1°F (1°C) increments.

*NOTE: When in the Ice Building mode, and the evaporator entering water temperature drops below the ice termination setpoint, the chiller terminates the Ice Building mode and changes to the Ice Building Complete Mode.*

## CAUTION

### Evaporator Damage!

**Freeze inhibitor must be adequate for the leaving water temperature. Failure to do so will result in damage to system components.**

Techview must also be used to enable or disable Ice Machine Control. This setting does not prevent the Tracer from commanding Ice Building mode.

Upon contact closure, the CH530 will initiate an ice building mode, in which the unit runs fully loaded at all times. Ice building shall be terminated either by opening the contact or based on the entering evaporator water temperature. CH530 will not



## Installation - Electrical

permit the ice building mode to be reentered until the unit has been switched out of ice building mode (open 5K18 contacts) and then switched back into ice building mode (close 5K18 contacts.)

In ice building, all limits (freeze avoidance, evaporator, condenser, current) will be ignored. All safeties will be enforced.

If, while in ice building mode, the unit gets down to the freeze stat setting (water or refrigerant), the unit will shut down on a manually resettable diagnostic, just as in normal operation.

Connect leads from 5K18 to the proper terminals of 1U7. Refer to the field diagrams which are shipped with the unit.

Silver or gold-plated contacts are recommended. These customer furnished contacts must be compatible with 24 VDC, 12 mA resistive load.

### External Chilled Water Setpoint (ECWS) Option

The CH530 provides inputs that accept either 4-20 mA or 2-10 VDC signals to set the external chilled water setpoint (ECWS). This is not a reset function. The input defines the set point. This input is primarily used with generic BAS (building automation systems). The chilled water setpoint set via the DynaView or through digital communication with Tracer (Comm3). The arbitration of the various chilled water setpoint sources is described in the flow charts at the end of the section.

The chilled water setpoint may be changed from a remote location by sending either a 2-10 VDC or 4-20 mA signal to the 1U6, terminals 5 and 6 LLID. 2-10 VDC and 4-20 mA each correspond to a 10 to 65°F (-12 to 18°C) external chilled water setpoint.

The following equations apply:

	Voltage Signal	Current Signal
As generated from external source	$VDC=0.1455*(ECWS)+0.5454$	$mA=0.2909*(ECWS)+1.0909$
As processed by CH530	$ECWS=6.875*(VDC)-3.75$	$ECWS=3.4375*(mA)-3.75$

If the ECWS input develops an open or short, the LLID will report either a very high or very low value back to the main processor. This will generate an informational diagnostic and the unit will default to using the Front Panel (DynaView) Chilled Water Setpoint.

TechView Service Tool is used to set the input signal type from the factory default of 2-10 VDC to that of 4-20 mA. TechView is also used to install or remove the External Chilled Water Setpoint option as well as a means to enable and disable ECWS.

### External Current Limit Setpoint (ECLS) Option

Similar to the above, the CH530 also provides for an optional External Current Limit Setpoint that will accept either a 2-10 VDC (default) or a 4-20 mA signal. The Current Limit Setting can also be set via the DynaView or through digital communication with Tracer (Comm 3). The arbitration of the various sources of current limit is described in the flow charts at the end of this section. The External Current Limit Setpoint may be changed from a remote location by hooking up the analog input signal to the 1 U6 LLID terminals 2 and 3. Refer to the following paragraph on Analog Input Signal Wiring Details. The following equations apply for ECLS:

	Voltage Signal	Current Signal
As generated from external source	$VDC+0.133*(\%)-6.0$	$mA=0.266*(\%)-12.0$
As processed by UCM	$\%=7.5*(VDC)+45.0$	$\%=3.75*(mA)+45.0$

## Installation - Electrical

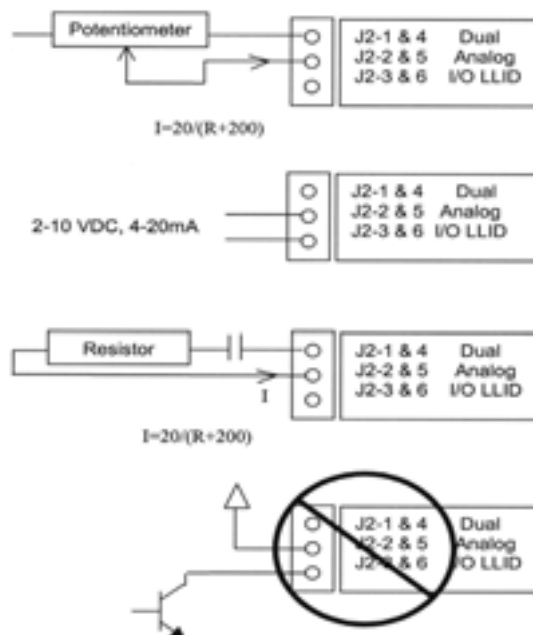
If the ECLS input develops an open or short, the LLID will report either a very high or very low value back to the man processor. This will generate an informational diagnostic and the unit will default to using the Front Panel (DynaView) Current Limit Setpoint.

The TechView Service Tool must be used to set the input signal type from the factory default of 2-10 VDC to that of 4-20 mA current. TechView must also be used to install or remove the External Current Limit Setpoint Option for field installation, or can be used to enable or disable the feature (if installed).

ECLS and ECWS Analog Input Signal Wiring Details:

Both the ECWS and ECLS can be connected and setup as either a 2-10 VDC (factory default), 4-20 mA, or resistance input (also a form of 4-20mA) as indicated below. Depending on the type to be used, the TechView Service Tool must be used to configure the LLID and the MP for the proper input type that is being used. This is accomplished by a setting change on the Custom Tab of the Configuration View within TechView.

The J2-3 and J2-6 terminal is chassis grounded and terminal J2- 1 and J2-4 can be used to source 12 VDC. The ECLS uses terminals J2-2 and J2-3. ECWS uses terminals J2-5 and J2-6. Both inputs are only compatible with high-side current sources.



**Figure 32** Wiring Examples for ECLS and ECWS

### Chilled Water Reset (CWR)

CH530 resets the chilled water temperature set point based on either return water temperature, or outdoor air temperature. Return Reset is standard, Outdoor Reset is optional.

The following shall be selectable:

- One of three Reset Types: None, Return Water Temperature Reset, Outdoor Air Temperature Reset, or Constant Return Water Temperature Reset.
- Reset Ratio Set Points.

For outdoor air temperature reset there shall be both positive and negative reset ratio's.

## Installation - Electrical

- Start Reset Set Points.
- Maximum Reset Set Points.

The equations for each type of reset are as follows:

### Return

$$CWS' = CWS + \text{RATIO} (\text{START RESET} - (\text{TWE} - \text{TWL}))$$

and  $CWS' \geq CWS$

and  $CWS' - CWS \leq \text{Maximum Reset}$

### Outdoor

$$CWS' = CWS + \text{RATIO} * (\text{START RESET} - \text{TOD})$$

and  $CWS' \geq CWS$

and  $CWS' - CWS \leq \text{Maximum Reset}$

### where

CWS' is the new chilled water set point or the "reset CWS"

CWS is the active chilled water set point before any reset has occurred, e.g. normally Front Panel, Tracer, or ECWS

RESET RATIO is a user adjustable gain

START RESET is a user adjustable reference

TOD is the outdoor temperature

TWE is entering evap. water temperature

TWL is leaving evap. water temperature

MAXIMUM RESET is a user adjustable limit providing the maximum amount of reset. For all types of reset,  $CWS' - CWS \leq \text{Maximum Reset}$ .

Reset Type	Reset Ratio Range	Start Reset Range	Maximum Reset Range	Increment English Units	Increment SI Units	Factory Default Value
Return:	10 to 120%	4 to 30 F (2.2 to 16.7 C)	0 to 20 F (0.0 to 11.1 C)	1%	1%	50%
Outdoor	80 to -80%	50 to 130 F (10 to 54.4 C)	0 to 20 F (0.0 to 11.1 C)	1%	1%	10%

In addition to Return and Outdoor Reset, the MP provides a menu item for the operator to select a Constant Return Reset. Constant Return Reset will reset the leaving water temperature set point so as to provide a constant entering water temperature. The Constant Return Reset equation is the same as the Return Reset equation except on selection of Constant Return Reset, the MP will automatically set Ratio, Start Reset, and Maximum Reset to the following.

RATIO = 100%

START RESET = Design Delta Temp.

MAXIMUM RESET = Design Delta Temp.

The equation for Constant Return is then as follows:

$$CWS' = CWS + 100\% (\text{Design Delta Temp.} - (\text{TWE} - \text{TWL}))$$

and  $CWS' \geq CWS$

and  $CWS' - CWS \leq \text{Maximum Reset}$

When any type of CWR is enabled, the MP will step the Active CWS toward the desired CWS' (based on the above equations and setup parameters) at a rate of 1 degree F every 5 minutes until the Active CWS equals the desired CWS'. This applies when the chiller is running.



# Installation - Electrical

When the chiller is not running the CWS is reset immediately (within one minute) for Return Reset and at a rate of 1 degree F every 5 minutes for Outdoor Reset. The chiller will start at the Differential to Start value above a fully reset CWS or CWS' for both Return and Outdoor Reset.

## Communications Interface options

### Optional Tracer Communications Interface

This option allows the Tracer CH530 controller to exchange information (e.g. operating setpoints and Auto/Standby commands) with a higher-level control device, such as a Tracer Summit or a multiple-machine controller. A shielded, twisted pair connection establishes the bi-directional communications link between the Tracer CH530 and the building automation system.

**To prevent control malfunctions, do not run low voltage wiring (<30 V) in conduit with conductors carrying more than 30 volts.**

Field wiring for the communication link must meet the following requirements:

- All wiring must be in accordance with the NEC and local codes.
- Communication link wiring must be shielded, twisted pair wiring (Belden 8760 or equivalent). See the table below for wire size selection:

**Table 23 Wire Size**

Wire Size	Maximum Length of Communication Wire
14 AWG (2.5 mm <sup>2</sup> )	5,000 FT (1525 m)
16 AWG (1.5 mm <sup>2</sup> )	2,000 FT (610 m)
18 AWG (1.0 mm <sup>2</sup> )	1,000 FT (305 m)

- The communication link cannot pass between buildings.
- All units on the communication link can be connected in a "daisy chain" configuration.

### LonTalk Communications Interface for Chillers (LCI-C)

CH530 provides an optional LonTalk Communication Interface (LCI-C) between the chiller and a Building Automation System (BAS). An LCI-C LLID shall be used to provide "gateway" functionality between a LonTalk compatible device and the Chiller. The inputs/outputs include both mandatory and optional network variables as established by the LonMark Functional Chiller Profile 8040.

### Installation Recommendations

- 22 AWG Level 4 unshielded communication wire recommended for most LCI-C installations
- LCI-C link limits: 4500 feet, 60 devices
- Termination resistors are required
  - 105 ohms at each end for Level 4 wire
  - 82 ohms at each end for Trane "purple" wire
- LCI-C topology should be daisy chain
- Zone sensor communication stubs limited to 8 per link, 50 feet each (maximum)
- One repeater can be used for an additional 4500 feet, 60 devices, 8 communication stubs

# Installation - Electrical

**Table 24 LonTalk Points List**

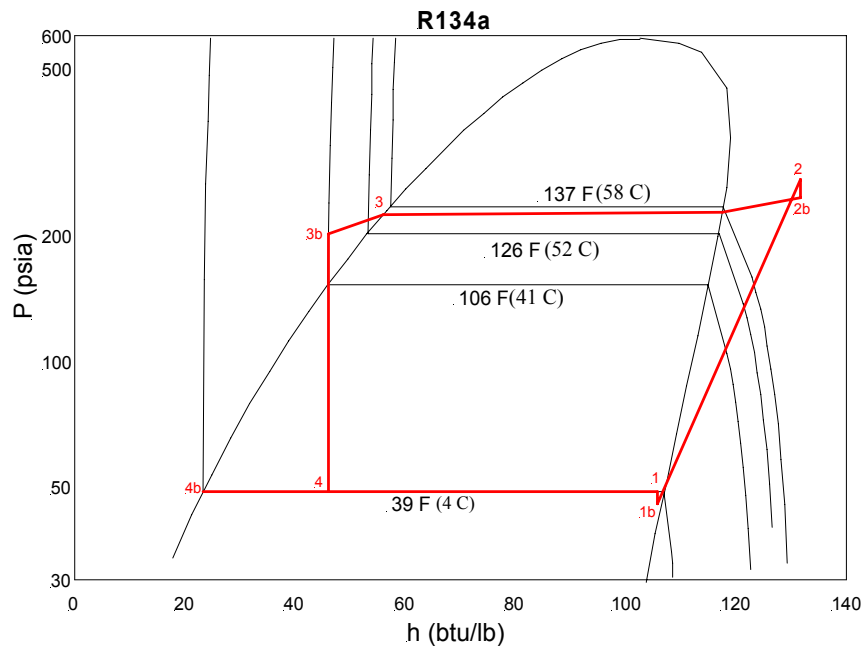
<b>LonTalk Communications Interface</b>			
<b>Inputs</b>	<b>Variable type</b>		<b>SNVT_Type</b>
Chiller Enable/Disable	binary	start(1)/stop(0)	SNVT_switch
Chilled Water Setpoint	analog	temperature	SNVT_temp_p
Current Limit Setpoint	analog	% current	SNVT_lev_percent
Chiller Mode	Note 1		SNVT_hvac_mode
<b>Outputs</b>	<b>Variable type</b>		<b>SNVT_Type</b>
Outputs	Variable type		SNVT_Type
Chiller On/Off	binary	on(1)/off(0)	SNVT_switch
Active Chilled Water Setpoint	analog	temperature	SNVT_temp_p
Percent RLA	analog	% current	SNVT_lev_percent
Active Current Limit Setpoint	analog	% current	SNVT_lev_percent
Leaving Chilled Water Temperature	analog	temperature	SNVT_temp_p
Entering Chilled Water Temperature	analog	temperature	SNVT_temp_p
Entering Condenser Water Temperature	analog	temperature	SNVT_temp_p
Leaving Condenser Water Temperature	analog	temperature	SNVT_temp_p
Alarm Description	Note 2		SNVT_str_asc
Chiller Status	Note 3		SNVT_chlr_status
Note 1: Chiller Mode is used to place the chiller into an alternate mode; Cool or Ice Build			
Note 2: Alarm Description denotes alarm severity and target. Severity: no alarm, warning, normal shutdown, immediate shutdown Target: Chiller, Platform, Ice Building (Chiller is refrigerant circuit and Platform is control circuit)			
Note 3: Chiller Status describes Chiller Run Mode and Chiller Operating Mode. Run Modes: Off, Starting, Running, Shutting Down Operating Modes: Cool, Ice Build States: Alarm, Run Enabled, Local Control, Limited, CHW Flow, Cond Flow			

## Operating Principles

This section contains an overview of the operation and maintenance of RTAC units equipped with CH530 control systems. It describes the overall operating principles of the RTAC design.

### Refrigeration Cycle

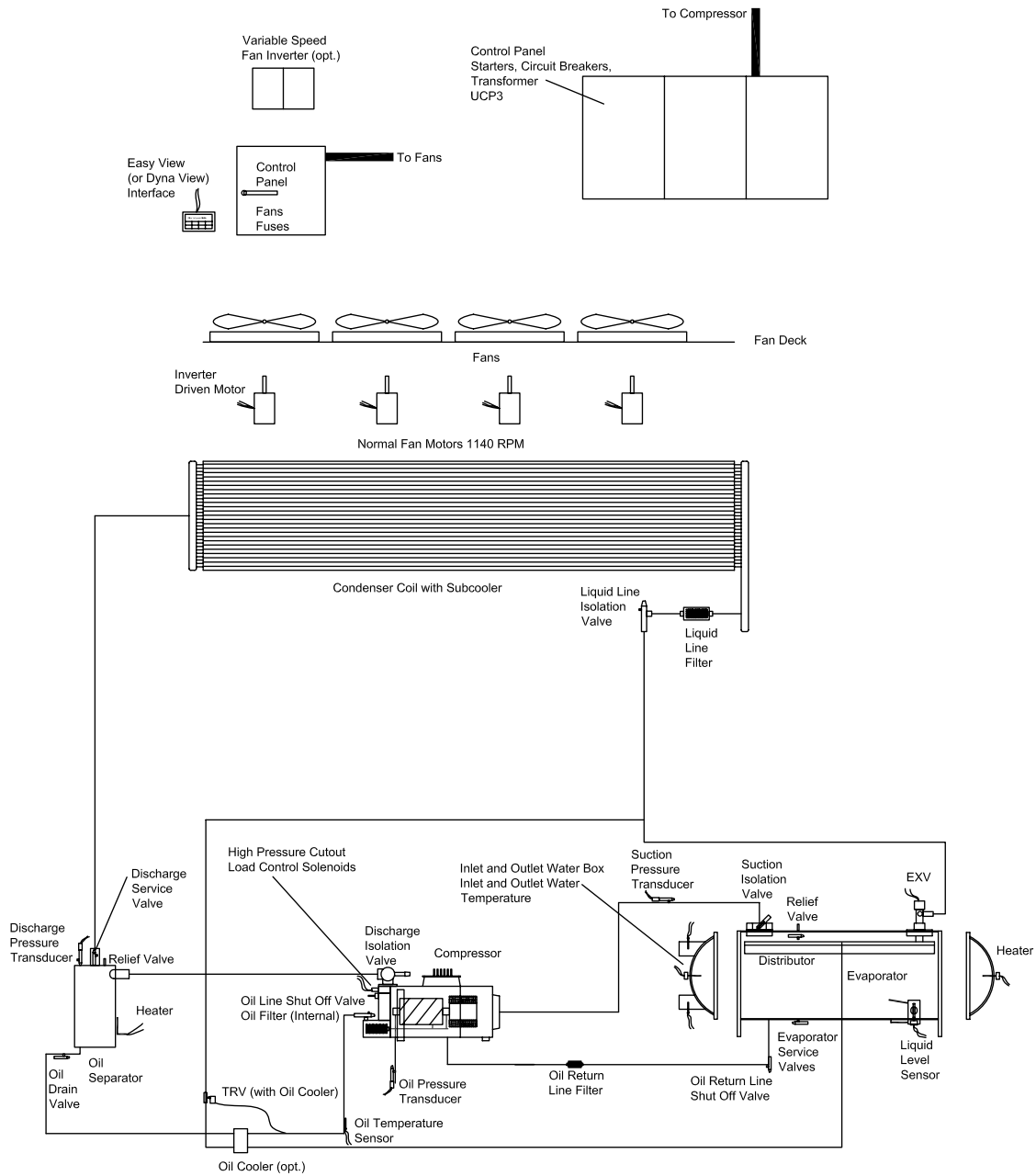
The refrigeration cycle of the RTAC chiller is similar to that of the RTAA air cooled water chiller. The exception is that the evaporating and condensing temperatures have been increased to allow for optimization of the chiller and reduced foot print. The refrigeration cycle is represented in the pressure enthalpy diagram in [Figure 33](#). Key state points are indicated on the figure. The cycle for the full load ARI design point is represented in the plot.



**Figure 33** Pressure Enthalpy (P-h) diagram of RTAC chiller

The RTAC chiller uses a shell and tube evaporator design with refrigerant evaporating on the shell side and water flowing inside tubes having enhanced surfaces (states 4 to 1). The suction lines and bolt pads are designed to minimize pressure drop (states 1 to 1b). The compressor is a twin-rotor helical rotary compressor designed similarly to the compressors offered in other Trane Screw Compressor Based Chillers (states 1b to 2). The discharge lines include a highly efficient oil separation system that virtually removes all oil from the refrigerant stream going to the heat exchangers (states 2 to 2b). De-superheating, condensing and sub-cooling is accomplished in a fin and tube air cooled heat exchanger where refrigerant is condensed in the tube (states 2b to 3b). Refrigerant flow through the system is balanced by an electronic expansion valve (states 3b to 4).

# Operating Principles



**Figure 34 System Schematic**



# Operating Principles

---

## Refrigerant R134a

The RTAC chiller uses environmentally friendly R134a. Trane believes that responsible refrigerant practices are important to the environment, our customers, and the air conditioning industry. All technicians who handle refrigerants must be certified. The Federal Clean Air Act (Section 608) sets forth the requirements for handling, reclaiming, recovering and recycling of certain refrigerants and the equipment that is used in these service procedures. In addition, some states or municipalities may have additional requirements that must also be adhered to for responsible management of refrigerants. Know the applicable laws and follow them.

R134a is a medium pressure refrigerant. It may not be used in any condition that would cause the chiller to operate in a vacuum without a purge system. RTAC is not equipped with a purge system. Therefore, the RTAC chiller may not be operated in a condition that would result in a saturated condition in the chiller of  $-15^{\circ}\text{F}$  ( $-26^{\circ}\text{C}$ ) or lower.

R134a requires the use of specific POE oils as designated on the unit nameplate.

**Important!** The RTAC units must only operate with R-134a and Trane Oil 00048.

## Compressor

The compressor is a semi-hermetic, direct-drive rotary type compressor. Each compressor has only four moving parts: two rotors that provide compression and male and female load-control valves. The male rotor is attached to the motor and the female rotor is driven by the male rotor. The rotors and motor are supported by bearings.

The helical rotary compressor is a positive displacement device. Refrigerant vapor from the evaporator is drawn into the suction opening of the compressor (state 1b), through a suction strainer screen across the motor (which provides motor cooling) and into the intake of the compressor rotors. The gas is then compressed and discharged through a check valve and into the discharge line (state 2).

There is no physical contact between the rotors and the compressor housing. The rotors contact each other at the point where the driving action between the male and female rotors occurs. Oil is injected into the rotors of the compressor, coating the rotors and the compressor housing interior. Although this oil does provide rotor lubrication, its primary purpose is to seal the clearance spaces between the rotors and compressor housing. A positive seal between these internal parts enhances compressor efficiency by limiting leakage between the high pressure and low pressure cavities.

Capacity control is accomplished by means of a female step load-control valve and a male control valve. The female step valve is the first stage of loading after the compressor starts and the last stage of unloading before the compressor shuts down. The male control valve is positioned by a piston cylinder along the length of the male rotor. Compressor capacity is dictated by the position of the loading valve relative to the rotors. When the valve slides toward the discharge end of the rotors compressor capacity is reduced.

## Condenser and Subcooler

The condenser and subcooler are similar to the condenser used in RTAA chillers. The heat exchanger consists of  $3/8''$  tubes that contain the refrigerant, large fins that are in the air flow and fans that draw air through the fins. Heat is transferred from the refrigerant through the tubes and fins to the air.

High pressure gas from the compressor enters the tubes of the condenser through a distribution header (state 2b). As refrigerant flows through the tubes, the heat of compression and cooling load are rejected to the air. In this process the refrigerant is de-superheated, condensed (states 2b to 3) and finally subcooled (states 3 to 3b) to a temperature slightly above the ambient air temperature. The subcooled liquid refrigerant is collected in the leaving header where it is transferred to the liquid line (state 3b).

A controls algorithm always runs as many fans as possible without reducing the differential pressure (discharge minus suction) below the setpoint (60 psid or 4.2 bar). If a warm enough ambient is sensed, all the fans will run. If the ambient is cooler,



## Operating Principles

---

some fans are shut off to maintain the pressure differential. Fan staging depends on the chiller load, evaporator pressure, condenser effectiveness, ambient temperature, and numbers and sizes of fans installed on the circuit.

The algorithm pre-starts fans (based on ambient and water temperatures) when a circuit starts the compressor. (For rare conditions such as during some pull-downs, a steady fan state would either violate the 60 psid (4.2 bar) setpoint or cause a high pressure cut-out; in those conditions a fan will cycle on and off.)

For up to two minutes after chiller start-up, the setpoint is 35 psi (2.45 bar) difference, and then before the controls adjust gradually over half a minute up to 60 psi (4.2 bar).

### Expansion Valve

Pressure drop occurs in an electronic expansion valve. The unit controller (CH530) uses the valve to regulate the flow through the liquid line to match the flow produced by the compressor. The valve has a variable orifice that is modulated by a stepper motor.

High pressure, subcooled liquid refrigerant enters the expansion valve from the liquid line. As refrigerant passes through the valve the pressure is dropped substantially, which results in vaporization of some of the refrigerant. The heat of vaporization is supplied by the two phase mixture resulting in low temperature low pressure refrigerant which is supplied to the evaporator (state 4) to provide cooling.

### Evaporator

The evaporator is composed of a liquid-vapor distributor and falling film evaporator.

A liquid-vapor refrigerant mixture enters the distributor (state 4). The mixture is distributed over the length of the evaporator tubes (state 4b). Liquid is evenly distributed over the length of the evaporator tubes by the two-phase distribution system. A portion of the liquid boils as it falls by gravity from tube to tube, wetting all the tubes of the evaporator. To ensure that the tubes at the bottom of the evaporator do not experience "dry out," a liquid pool is maintained in the bottom few inches of the bundle. Tubes located in the bottom of the evaporator will evaporate the liquid refrigerant by boiling (pool boiling).

Heat is transferred from the water or glycol inside the tubes to the liquid refrigerant as the film of refrigerant evaporates on the surface of the tube. Thin film heat transfer requires a smaller temperature difference for a given amount of heat transfer than nucleate boiling, which is the heat transfer process used in flooded evaporators. Hence, efficiency is enhanced by the use of falling film evaporation. Additionally, the evaporator requires less refrigerant than a comparable flooded evaporator and the evaporator boils the entire refrigerant supply at constant pressure. Refrigerant vapor exits the evaporator through the suction line (state 1).

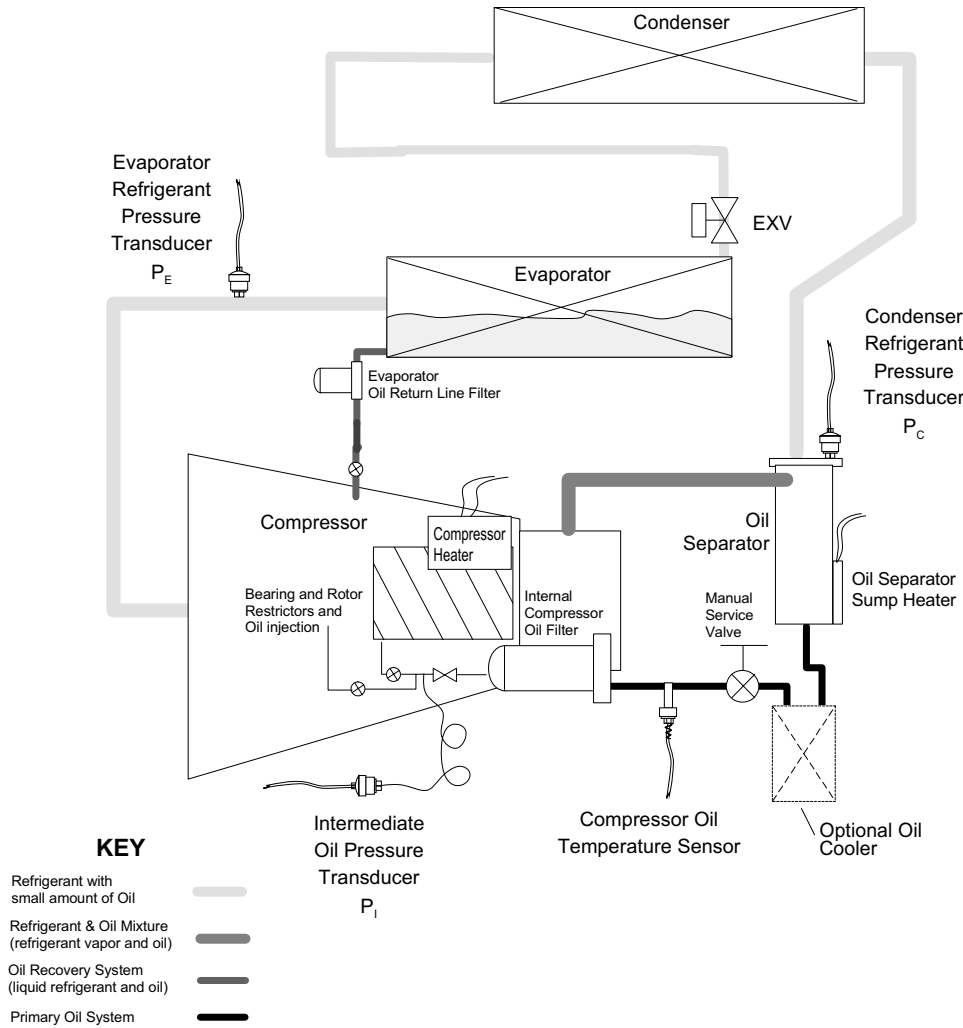
### Oil System

Screw compressors require large quantities of oil for lubricating and sealing the rotors and lubricating the bearings. This oil is mixed with refrigerant at the discharge of the compressor. To enhance the performance of the heat exchanger surfaces an oil separation system is placed into the discharge line. The oil separator is located between the compressor and the condenser. It separates oil using highly efficient centrifugal force. Approximately 99.5% of the oil is removed from the refrigerant in the separator.

Oil that is removed from the refrigerant falls by gravity into the oil sump. This oil is directed back to the compressor through the oil lines. Internal to the compressor is a high efficiency filter to clean the oil before it is delivered to the rotors and bearings. Once oil is injected into the compressor rotors it mixes with the refrigerant again and is delivered back to the discharge line.

# Operating Principles

Oil that gets past the oil separators flows through the condenser, subcooler and expansion valve into the evaporator. This oil is collected in the pool of refrigerant that is maintained in the bottom of the evaporator. A small amount of oil and refrigerant from this pool (state 4b) is returned through a line that is connected to the compressor down stream of the motor. This oil and refrigerant mixes with the refrigerant vapor that was drawn out of the evaporator, prior to injection into the compressor rotors.



**Figure 35 RTAC Oil System**



# Controls Interface

---

## CH530 Communications Overview

The Trane CH530 control system that runs the chiller consists of several elements:

- The main processor collects data, status, and diagnostic information and communicates commands to the starter module and the LLID (for Low Level Intelligent Device) bus. The main processor has an integral display (DynaView).
- Higher level modules (e.g. starter) exist only as necessary to support system level control and communications. The starter module provides control of the starter when starting, running, and stopping the chiller motor. It also processes its own diagnostics and provides motor and compressor protection.
- Low level intelligent device (LLID) bus. The main processor communicates to each input and output device (e.g. temperature and pressure sensors, low voltage binary inputs, analog input/output) all connected to a four-wire bus, rather than the conventional control architecture of signal wires for each device.
- The communication interface to a building automation system (BAS).
- A service tool to provide all service/maintenance capabilities.

Main processor and service tool (TechView) software is downloadable from [www.Trane.com](http://www.Trane.com). The process is discussed later in this section under TechView Interface.

DynaView provides bus management. It has the task of restarting the link, or filling in for what it sees as "missing" devices when normal communications has been degraded. Use of TechView may be required.

The CH530 uses the IPC3 protocol based on RS485 signal technology and communicating at 19.2 Kbaud to allow 3 rounds of data per second on a 64-device network. A typical four-compressor RTAC will have around 50 devices.

Most diagnostics are handled by the DynaView. If a temperature or pressure is reported out of range by a LLID, the DynaView processes this information and calls out the diagnostic. The individual LLIDs are not responsible for any diagnostic functions. The only exception to this is the Starter module.

*NOTE: It is imperative that the CH530 Service Tool (TechView) be used to facilitate the replacement of any LLID or reconfigure any chiller component. TechView is discussed later in this section.*

## Controls Interface

Each chiller is equipped with a DynaView interface. The DynaView has the capability to display information to the operator including the ability to adjust settings. Multiple screens are available and text is presented in multiple languages as factory-ordered or can be easily downloaded from [www.trane.com](http://www.trane.com).

TechView can be connected to either the DynaView module and provides further data, adjustment capabilities, diagnostics information using downloadable software.

## DynaView Interface

The DynaView share the same enclosure design: weatherproof and durable plastic for use as a stand-alone device on the outside of the unit or mounted nearby.

The display on DynaView is a 1/4 VGA display with a resistive touch screen and an LED backlight. The display area is approximately 4 inches wide by 3 inches high (102mm x 60mm).

## Controls Interface

---



**Figure 36** DynaView

### Key Functions

In this touch screen application, key functions are determined completely by software and change depending upon the subject matter currently being displayed. The basic touch screen functions are outlined below.

### Radio Buttons

Radio buttons show one menu choice among two or more alternatives, all visible. (It is the AUTO button in [Figure 36](#).) The radio button model mimics the buttons used on old-fashioned radios to select stations. When one is pressed, the one that was previously pressed “pops out” and the new station is selected. In the DynaView model the possible selections are each associated with a button. The selected button is darkened, presented in reverse video to indicate it is the selected choice. The full range of possible choices as well as the current choice is always in view.

### Spin Value Buttons

Spin values are used to allow a variable setpoint to be changed, such as leaving water setpoint. The value increases or decreases by touching the increment (+) or decrement (-) arrows.

### Action Buttons

Action buttons appear temporarily and provide the user with a choice such as **Enter** or **Cancel**.

### Hot Links

Hot links are used to navigate from one view to another view.

### File Folder Tabs

File folder tabs are used to select a screen of data. Just like tabs in a file folder, these serve to title the folder/screen selected, as well as provide navigation to other screens. In DynaView, the tabs are in one row across the top of the display. The folder tabs are separated from the rest of the display by a horizontal line. Vertical lines separate the tabs from each other. The folder that is selected has no horizontal line under

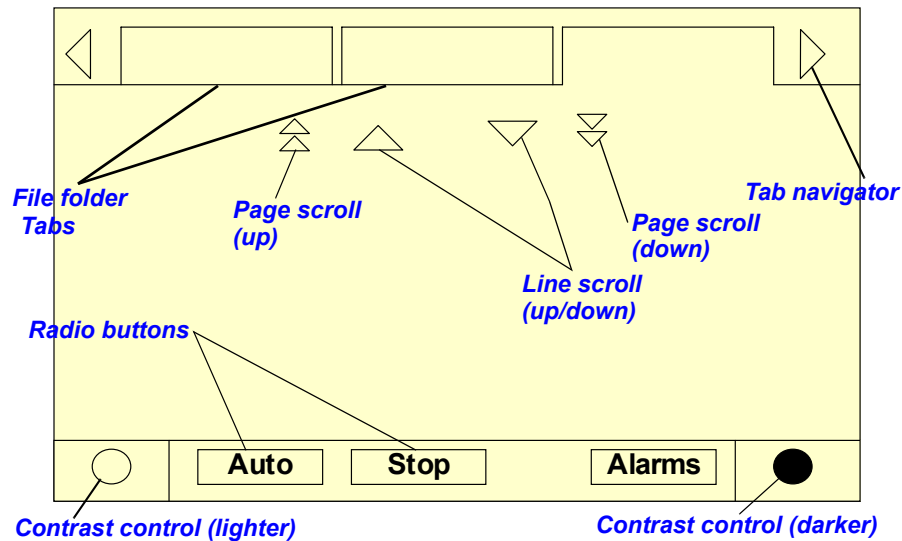
# Controls Interface

its tab, thereby making it look like a part of the current folder (as would an open folder in a file cabinet). The user selects a screen of information by touching the appropriate tab.

## Display Screens

### Basic Screen Format

The basic screen format appears as:



The file folder tabs across the top of the screen are used to select the various display screens.

Scroll arrows are added if more file tabs (choices) are available. When the tabs are at the left most position, the left navigator will not show and only navigation to the right will be possible. Likewise when the right most screen is selected, only left navigation will be possible.

The main body of the screen is used for description text, data, setpoints, or keys (touch sensitive areas). The Chiller Mode is displayed here.

The double up arrows cause a page-by-page scroll either up or down. The single arrow causes a line by line scroll to occur. At the end of the page, the appropriate scroll bar will disappear.

A double arrow pointing to the right indicates more information is available about the specific item on that same line. Pressing it will bring you to a subscreen that will present the information or allow changes to settings.

The bottom of the screen (Fixed Display) is present in all screens and contains the following functions. The **left circular area** is used to reduce the contrast/viewing angle of the display. **The right circular area** is used to increase the contrast/viewing angle of the display. The contrast may require re-adjustment at ambient temperatures significantly different from those present at last adjustment.

The other functions are critical to machine operation. The AUTO and STOP keys are used to enable or disable the chiller. The key selected is in black (reverse video). The chiller will stop when the STOP key is touched and after completing the Run Unload mode.

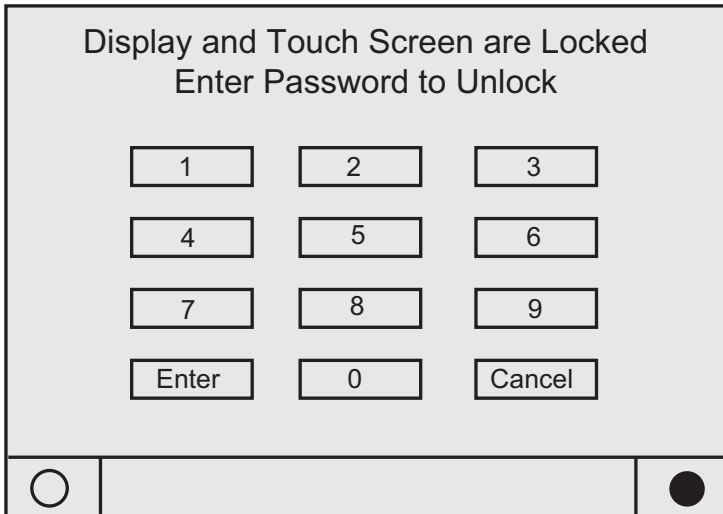
Touching the AUTO key will enable the chiller for active cooling if no diagnostic is present. (A separate action must be taken to clear active diagnostics.)

The AUTO and STOP keys, take precedence over the Enter and Cancel keys. (While a setting is being changed, AUTO and STOP keys are recognized even if Enter or Cancel has not been pressed.)

## Controls Interface

The ALARMS button appears only when an alarm is present, and blinks (by alternating between normal and reverse video) to draw attention to a diagnostic condition. Pressing the ALARMS button takes you to the corresponding tab for additional information.

### Front Panel Lockout Feature

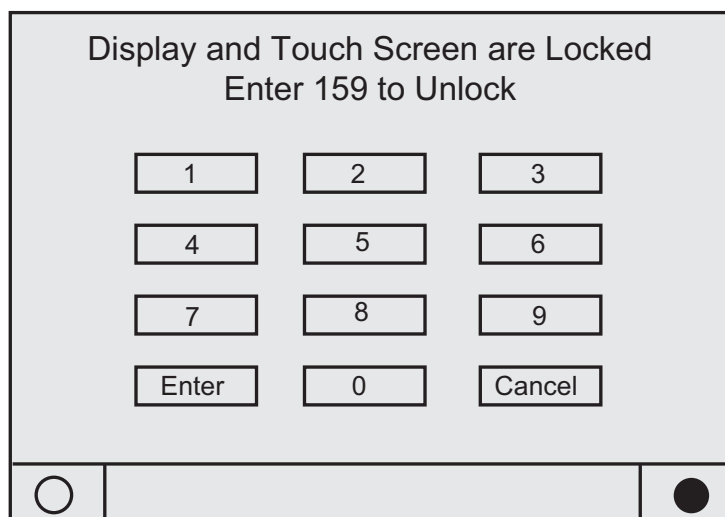


*NOTE: The DynaView display and Touch Screen Lock screen is shown below. This screen is used if the Display and touch screen and lock feature is enabled. Thirty minutes after the last keystroke, this screen is displayed and the Display and Touch Screen is locked out until the sequence "159 <ENTER>" is pressed.*

Until the proper password is entered, there will be no access to the DynaView screens including all reports, setpoints, and Auto/Stop/Alarms/Interlocks.

The password "159" is not programmable from either DynaView or TechView.

### Front Panel Display During Cold Ambients



# Controls Interface

If the Display and Touch Screen Lock feature is disabled, the following screen is automatically displayed if the DynaView Temperature is below freezing and has been 30 minutes after the last keystroke. Note: This feature is provided to avoid unintended actuations of the keypad, which can occur due to ice build-up on the DynaView's exterior surfaces. Also be aware that at extremes of temperatures, the LCD display screen will change its contrast from the optimal adjustment made at more normal temperatures. It can appear washed out or blacked out. Simply pressing the lower right contrast control on the screen will return the display to readable condition.

*NOTE: All screens shown in this section are typical. Some screens show all display options available, only one of which may appear on a line.*

## Modes Screen

The Mode Screen is only found on software revisions 18 and later. This screen provides a display for the top level operating mode for each of the components and sub-components of the chiller (i.e. Chiller, Circuits, and Compressors) that exist on the Chiller as it is configured. The modes are displayed as text only without the hex codes.

In software revisions 17.0 and earlier, the top level mode and the sub mode for each component was displayed on the respective component tab on the first two lines. The mode display of the first three lines of the Compressor and Chiller Screen tabs is eliminated with the addition of the Mode Screen

	Modes	Chiller	Compressor	▶
Chiller Mode:		Running		▶▶
Circuit 1 Mode:		Running - Limit		▶▶
Cprsr 1A Mode:		Running		▶▶
Cprsr 1B Mode:		Running		▶▶
Circuit 2 Mode:		Run Inhibit		▶▶
Cprsr 2A Mode:		Stopped		▶▶
Cprsr 2B Mode:		Stopped		▶▶
	○	<b>Auto</b>	Stop	●



# Controls Interface

Table 25 Chiller Modes

Chiller Modes	Description
<b>Top Level Mode</b>	
<b>Sub-modes</b>	
Stopped	The chiller is not running and cannot run without intervention. Further information is provided by the sub-mode:
Local Stop	Chiller is stopped by DynaView Stop button command - cannot be remotely overridden.
Panic Stop	Chiller is stopped by the DynaView Panic Stop (by pressing Stop button twice in succession) - previous shutdown was manually commanded to shutdown immediately without a run-unload or pumpdown cycle - cannot be remotely overridden.
Diagnostic Shutdown - Manual Reset	The chiller is stopped by a diagnostic that requires manual intervention to reset.
Other sub-modes are possible in conjunction with at least one of the above modes - See items below for their descriptions: Diagnostic Shutdown - Auto Reset Start Inhibited by Low Cond Temp Start Inhibited by Low Ambient Temp Start Inhibited by External Source Start Inhibited by BAS Waiting for BAS Communications Ice Building to Normal Transition Ice Building is Complete Design Note: Maximum Capacity was eliminated as a annunciator mode prior to any release	
Run Inhibit	The chiller is currently being inhibited from starting (and running), but may be allowed to start if the inhibiting or diagnostic condition is cleared. Further information is provided by the sub-mode:
Diagnostic Shutdown - Auto Reset	The entire chiller is stopped by a diagnostic that may automatically clear.
Start Inhibited by Low Cond Temp	The chiller is inhibited from starting by Low Condenser Temperature- Inhibit is active below either 25°F (can be disabled with proper freeze protection) or 0°F (limit set by design, cannot be disabled). As an exception, this will not stop a chiller already running.
Start Inhibited by Low Ambient Temp	The chiller is inhibited from starting (and running) by an outdoor air ambient temperature lower than a specified temperature - per user adjustable settings and can be disabled.
Start Inhibited by External Source	The chiller is inhibited from starting (and running) by the "external stop" hardwired input.



# Controls Interface

Table 25 Chiller Modes

Chiller Modes	Description
<b>Top Level Mode</b>	
<b>Sub-modes</b>	
Start Inhibited by BAS	The chiller is inhibited from starting (and running) by command from a Building Automation System via the digital communication link (com 3 or com 5).
Waiting for BAS Communications	This is a transient mode - 15-min. max, and is only possible if the chiller is in the Auto - Remote command mode. After a power up reset, it is necessary to wait for valid communication from a Building Automation System (Tracer) to know whether to run or stay inhibited. Either valid communication will be received from the Building Automation System (e.g. Tracer), or a communication diagnostic ultimately will result. In the latter case the chiller will revert to Local control.
Ice Building to Normal Transition	The chiller is inhibited from running for a brief period of time if it is commanded from active ice building mode into normal cooling mode via the ice building hardwired input or Tracer. This allows time for the external system load to "switchover" from an ice bank to the chilled water loop, and provides for a controlled pull down of the loop's warmer temperature. This mode is not seen if the ice making is automatically terminated on return brine temperature per the mode below.
Ice Building is Complete	The chiller is inhibited from running as the Ice Building process has been normally terminated on the return brine temperature. The chiller will not start unless the ice building command (hardwired input or Building Automation System command) is removed or cycled.
Auto	The chiller is not currently running but can be expected to start at any moment given that the proper conditions and interlocks are satisfied. Further information is provided by the sub-mode:
Waiting For Evap Water Flow	The chiller will wait up to 4 minutes in this mode for evaporator water flow to be established per the flow switch hardwired input.
Waiting for Need to Cool	The chiller will wait indefinitely in this mode, for an evaporator leaving water temperature higher than the Chilled Water Setpoint plus the Differential to Start.
Starting	The chiller is going through the necessary steps to allow the lead circuit and lead compressor to start.
No Sub Modes	
Running	At least one circuit and one compressor on the chiller are currently running. Further information is provided by the sub-mode:



# Controls Interface

**Table 25 Chiller Modes**

<b>Chiller Modes</b>	<b>Description</b>
<b>Top Level Mode</b>	
<b>Sub-modes</b>	
Unit is Building Ice	The chiller is running in the Ice Building Mode, and either at or moving towards full capacity available. Ice mode is terminated either with the removal of the ice mode command or with the return brine temperature falling below the Ice Termination Setpoint.
Running - Limited	At least one circuit and one compressor on the chiller are currently running, but the operation of the chiller as a whole is being actively limited by the controls.
Capacity Limited by High Evap Water Temp	This mode will occur if both the OA temperature is above 40°F and the Evap Leaving Water Temperature is above 75°F as is often the case in a high temperature pull-down. While in this mode, no compressors will be allowed to load past their minimum load capacity step, but it will not inhibit compressor staging. This mode is necessary to prevent nuisance trips due to Compressor Overcurrent or High Pressure Cutout. Reasonable pull-down rates can still be expected despite this limit.

**Table 26 Circuit Modes**

<b>Circuit Modes</b>	<b>Description</b>
<b>Top Level Mode</b>	
<b>Sub-modes</b>	
Stopped	The given circuit is not running and cannot run without intervention. Further information is provided by the sub-mode:
Front Panel Lockout	The circuit is manually locked out by the circuit lockout setting - the nonvolatile lockout setting is accessible through either the Dyna-View or TechView.
Diagnostic Shutdown - Manual Reset	The circuit has been shutdown on a latching diagnostic.
Other sub-modes are possible in conjunction with at least one of the above modes - See items below for their descriptions: Diagnostic Shutdown - Auto Reset Start Inhibited by External Source Start Inhibited by BAS	
Run Inhibit	The given circuit is currently being inhibited from starting (and running), but may be allowed to start if the inhibiting or diagnostic condition is cleared. Further information is provided by the sub-mode:
Diagnostic Shutdown - Auto Reset	The circuit has been shutdown on a diagnostic that may clear automatically.
Start Inhibited by External Source	The circuit is inhibited from starting (and running) by its "external circuit lockout" hardwired input.
Start Inhibited by BAS	The circuit is inhibited from starting (and running) by command from a Building Automation System via the digital communication link (com 3 or com 5).



# Controls Interface

**Table 26 Circuit Modes**

<b>Circuit Modes</b>	<b>Description</b>
<b>Top Level Mode</b>	
<b>Sub-modes</b>	
Auto	The given circuit is not currently running but can be expected to start at any moment given that the proper conditions and interlocks are satisfied.
No Sub Modes	
Starting	The given circuit is going through the necessary steps to allow the lead compressor on that circuit to start.
No Sub Modes	
Running	At least one compressor on the given circuit is currently running. Further information is provided by the sub-mode:
Establishing Min. Cap - Low Diff pressure	The circuit is experiencing low system differential pressure and is being force loaded, irregardless Chilled Water Temperature Control, to develop pressure sooner.
Running - Limited	At least one compressor on the given circuit is currently running, but the capacity of the circuit is being actively limited by the controls. Further information is provided by the sub-mode:
Capacity Limited by High Cond Press	The circuit is experiencing condenser pressures at or near the condenser limit setting. Compressors on the circuit will be unloaded to prevent exceeding the limits.
Capacity Limited by Low Evap Rfgt Temp	The circuit is experiencing saturated evaporator temperatures at or near the Low Refrigerant Temperature Cutout setting. Compressors on the circuit will be unloaded to prevent tripping.
Capacity Limited by Low Liquid Level	The circuit is experiencing low refrigerant liquid levels and the EXV is at or near full open. The compressors on the circuit will be unloaded to prevent tripping.
Shutting Down	The given circuit is still running but shutdown is imminent. The circuit is going through either a compressor run-unload mode or a circuit operational pumpdown to dry out the evaporator (cold OA ambient only). Shutdown is necessary due to one (or more) of the following sub-modes:
Operational Pumpdown	The circuit is in the process shutting down by performing an operational pumpdown just prior to stopping the last running compressor. The EXV is commanded closed. Pumpdown will terminate when both the liquid level and the evap pressure
Front Panel Lockout	The circuit has been manually locked out by the circuit lockout setting and is in the process of shutting down - the nonvolatile lockout setting is accessible through either the DynaView or TechView.
Diagnostic Shutdown - Manual Reset	The circuit is in the process of shutdown due to a latching diagnostic.
Diagnostic Shutdown - Auto Reset	The circuit is in the process of shutdown due to a diagnostic that may automatically clear.
Start Inhibited by External Source	The circuit is in the process of shutdown due to a command from the external circuit lockout hardwired input.
Start Inhibited by BAS	The circuit is in the process of shutdown due to a command from the Building Automation System (e.g. Tracer)
Service Override	The given circuit is in a Service Override mode
Service Pumpdown	The circuit is running with fan control, via a manual command to perform a Service Pumpdown. Its respective EXV is being held wide open, but the manual liquid line service valve should be closed.



# Controls Interface

**Table 27 Compressor Modes**

Compressor Modes	Description
<b>Top Level Mode</b>	
<b>Sub-modes</b>	
Stopped	The given compressor is not running and cannot run without intervention. Further information is provided by the sub-mode:
Diagnostic Shutdown - Manual Reset	The compressor has been shutdown on a latching diagnostic.
Service Tool Lockout	The compressor has been shutdown due to a command from the TechView Service Tool to be "locked out" and inoperative. This setting is nonvolatile and operation can only be restored by using TechView to "unlock" it.
Other sub-modes are possible in conjunction with at least one of the above modes - See items below for their descriptions: Diagnostic Shutdown - Auto Reset Restart Inhibit	
Run Inhibit	The given compressor is currently being inhibited from starting (and running*), but may be allowed to start if the inhibiting or diagnostic condition is cleared. Further information is provided by the sub-mode:
Diagnostic Shutdown - Auto Reset	The compressor has been shutdown on a diagnostic that may clear automatically.
Restart Inhibit	The compressor is currently unable to start due to its restart inhibit timer. A given compressor is not allowed to start until 5 minutes has expired since its last start.
Auto	The given compressor is not currently running but can be expected to start at any moment given that the proper conditions occur.
No Sub Modes	
Starting	The given compressor is going through the necessary steps to allow it to start. (This mode is short and transitory)
No Sub Modes	
Running	The given compressor is currently running. Further information is provided by the sub-mode:
Establishing Min. Capacity - High Oil Temp	The compressor is running and is being forced loaded to its step load point, without regard to the leaving water temperature control, to prevent tripping on high oil temperature.
Running - Limited	The given compressor is currently running, but its capacity is being actively limited by the controls. Further information is provided by the sub-mode:
Capacity Limited by High Current	The compressor is running and its capacity is being limited by high currents. The current limit setting is 120% RLA (to avoid overcurrent trips) or lower as set by the compressor's "share" of the active current limit (demand limit) setting for the entire chiller.
Capacity Limited by Phase Unbalance	The compressor is running and its capacity is being limited by excessive phase current unbalance.
Shutting Down	The given compressor is still running but shutdown is imminent. The compressor is going through either a run-unload mode or is the active compressor in the operational pumpdown cycle for its circuit. Shutdown is either normal (no sub-mode displayed) or due the following sub-modes:
Diagnostic Shutdown - Manual Reset	The compressor is in the process of shutdown due to a latching diagnostic.

# Controls Interface

**Table 27 Compressor Modes**

Compressor Modes	Description
<b>Top Level Mode</b>	
<b>Sub-modes</b>	
Diagnostic Shutdown - Auto Reset	The compressor is in the process of shutdown due to a diagnostic that may clear automatically.
Service Tool Lockout	The compressor is in the process of shutdown due to a command from the TechView Service Tool to be "locked out" and inoperative. This setting is nonvolatile and operation can only be restored by using TechView to "unlock" it.

## Chiller Screen

The chiller screen is a summary of the chiller activity.

Modes	Chiller	Compressor	▶
Evap Leaving Water Temperature:			44.0 F
Evap Entering Water Temperature:			54.0 F
Active Chilled Water Setpoint:		▶▶	44.0 F
Active Current Limit Setpoint:		▶▶	100 %
Outdoor Air Temperature:			72.0 F
Software Version:			18.0
<input type="radio"/>	Auto	Stop	<input checked="" type="radio"/>

**Table 28 Chiller Screen**

Description	Resolution	Units
Evap Leaving Water Temperature	X.X	F / C
Evap Entering Water Temperature	X.X	F / C
Active Chilled Water Setpoint	X.X	F / C
Active Current Limit Setpoint	X	% RLA
Out Door Temperature	X.X	F / C
Software Type	RTA	Text
Software Version	X.XX	Text

## Compressor Screen

The compressor screen displays information for the one, two, three, or four compressors in the format shown. The top line of radio buttons allows you to select the compressor of interest. The next three lines show the compressor operating mode. The compressor radio buttons and the compressor operating mode lines don't change as you scroll down in the menu.

The top screen has no upward scroll keys. The single arrow down scrolls the screen one line at a time. As soon as the display is one line away from the top, the upward pointing arrow appears.

The last screen has a single arrow to scroll upward one line at a time. When in the last position, the single down arrow disappears.



# Controls Interface

Each compressor has its own screen depending on which radio key is pressed. When toggling between compressor screens, say to compare starts and run time, the same lines can be seen without additional key strokes. For example, toggling from the bottom of the compressor 1A menu accesses the top of the compressor 2A menu.

Modes	Chiller	Compressor	▶
▼	<b>1A</b>	1B	2A
Amps L1 L2 L3:		55.0	56.2 54.3
% RLA:		86.0	88.4 84.3
Unit Volts:		460	
Oil Temperature:		95.0	F
Intermediate Oil Pressure:		102.9	psig
Suction Pressure:		32.6	psig
○	<b>Auto</b>	Stop	●

**Table 29 Compressor Screen**

Description	Resolution	Units
Amps L1 L2 L3	XXX	Amps
% RLA L1 L2 L3	X.X	% RLA
Unit Volts	XXX	Volts
Oil Temperature	X.X	F / C
Intermediate Oil Pressure	X.X	Pressure
Suction Pressure	X.X	Pressure
Starts/ Run Hours	X, XX:XX	hr:min

## Refrigerant Screen

The refrigerant screen displays those aspects of the chiller related to the refrigerant circuits.

◀	Chiller	Compressor	Rfgt.	▶
			<u>Ckt 1</u>	<u>Ckt 2</u>
Cond Rfgt Pressure:		185.0	185.0	psig
Sat Cond Rfgt Temp:		125.0	125.0	F
Evap Rfgt Pressure:		30.0	30.0	psig
Sat Evap Rfgt Temp:		34.0	34.0	F
Evap Approach Temp:		4.0	4.0	F
Rfgt Liquid Level:		0.1	-0.1	in
○	<b>Auto</b>	Stop		●

# Controls Interface

**Table 30 Refrigerant Screen**

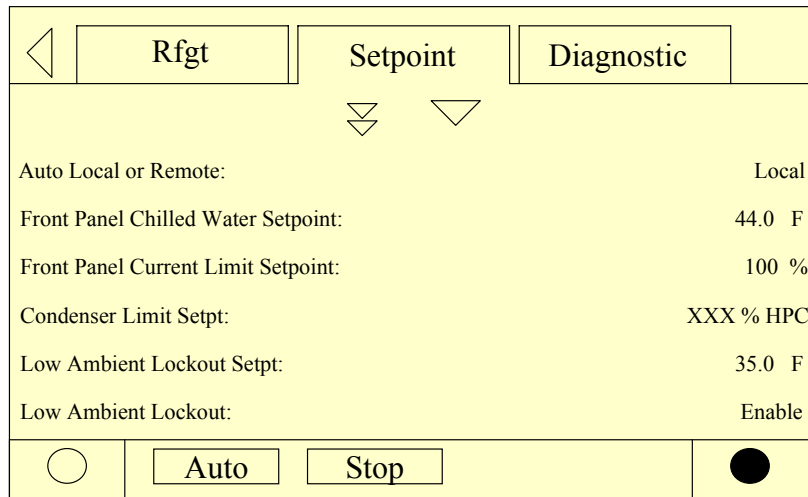
Description	Resolution	Units
Cond Rfgt Pressure Ckt1/Ckt2	X.X	Pressure
Sat Cond Rfgt Temp Ckt1/Ckt2	X.X	F / C
Evap Rfgt Pressure Ckt1/Ckt2	X.X	Pressure
Sat Evap Rfgt Temp Ckt1/Ckt2	X.X	F / C
Evap Approach Temp Ckt1/Ckt2	X.X	F / C
Rfgt Liquid Level Ckt1/Ckt2	X.X	Height

## Setpoint Screen

The setpoint screen is a two-part screen. Screen 1 lists all setpoints available to change along with their current value. The operator selects a setpoint to change by touching either the verbal description or setpoint value. Doing this causes the screen to switch to Screen 2.

In Screen 1 the language setpoint will always be the last setpoint in the list. This will facilitate language changes by placing that control in a standard position across all CH.530 product lines.

Screen 2 displays the current value of the chosen setpoint in the upper ½ of the display. It is displayed in a changeable format consistent with its type. Binary setpoints are considered to be simple two state enumeration and will use radio buttons. Analog setpoints are displayed as spin buttons. The lower half of the screen is reserved for help screens.



**Table 31 Setpoint Screen**

Description	Resolution or Text	Units
Auto Local or Remote	Remote/Local	Text
Front Panel Chilled Water Setpoint	X.X	F / C
Front Panel Current Limit Setpoint	XXX	% RLA
Differential to Start	X.X	Temperature
Differential to Stop	X.X	Temperature
Condenser Limit Setpoint	Enable/Disable	Text
Low Ambient Lockout Setpoint	X.X	Temperature
Low Ambient Lockout	Enable/Disable	Text
Ice Build	Enable/Disable	Text
Front Panel Ice Termination Setpoint	X.X	Temperature



# Controls Interface

**Table 31 Setpoint Screen**

Description	Resolution or Text	Units
Comp 1A Pumpdown	Pumpdown/Abort	Text
Comp 1B Pumpdown	Pumpdown/Abort	Text
Comp 2A Pumpdown	Pumpdown/Abort	Text
Comp 2B Pumpdown	Pumpdown/Abort	Text
EXV Ckt 1 Open	Auto/Open	Text
EXV Ckt 2 Open	Auto/Open	Text
Front Panel Ckt 1 Lockout	Locked Out/Not Locked Out	Text
Front Panel Ckt 2 Lockout	Locked Out/Not Locked Out	Text
Ext Chilled Water Setpoint	X.X	F / C
Ext Current Limit Setpoint	XXX	% RLA
Date Format	mmm dd yyyy, dd mm yyyy	Text
Date		Text
Time Format	12 hr, 24 hr	Text
Time of Day		Text
Keypad/Display Lockout	Enable/Disable	Text
Display Units	SI, English	Text
Pressure Units	Absolute, Gauge	Text
Language Selection	Downloaded from TechView	Text

**Table 32 Setpoint Options/Conditions Displayed**

Option	Condition(s)	Explanation
Ice Building	Enable/Disable	If feature is installed, operation can be initiated or stopped
Cprsr Pumpdown <sup>1</sup>	Avail	Pumpdown is allowed: only with unit in Stop or when circuit is locked out
	Not Avail	Pumpdown is not allowed because unit is operating or pumpdown has been completed
	Pumpdown	State is displayed while pumpdown is in progress
EXV Ckt Open (For Authorized Service Use Only <sup>2</sup> )	Avail	Indicates EXV is closed but can be opened manually since unit is in Stop or circuit is locked out
	Not Avail	EXV is closed but cannot be opened manually since unit is operating
	Open	State is displayed when EXV is open. Unit will not start with EXV manually set open, but will initiate valve closure first.
Ckt Lockout	Locked Out	Circuit is locked out at Front Panel; other circuit may be available to run
	Not Locked Out	Circuit is not locked out and is available to run
Ext. Chilled Water Setpt	Enable/Disable	Allows unit to control setpoint; otherwise another loop controller in line will control, as optionally wired.
Ext. Current Limit Setpt	Enable/Disable	Allows unit to control setpoint; otherwise another loop controller in line will control, as optionally wired.

Notes:

<sup>1</sup> Pumpdown procedure are discussed in Maintenance section 10.

<sup>2</sup> Used for liquid level control or to recover from pumpdown

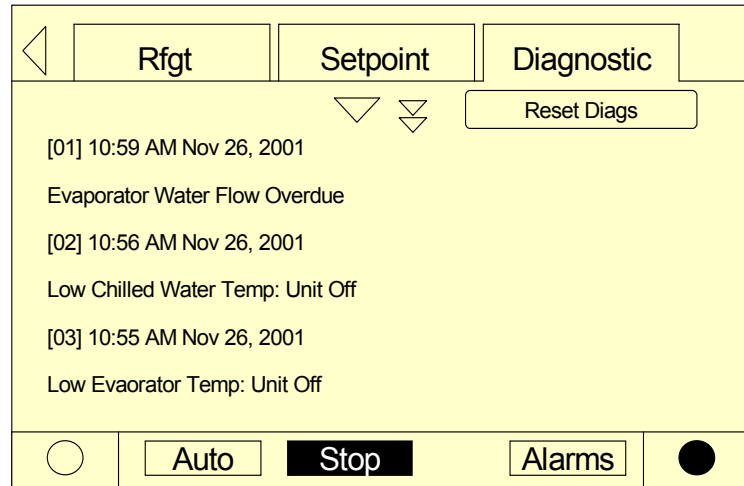
## Diagnostic Screen

The diagnostic screen (shown following) is accessible by either pressing the blinking ALARMS key or by pressing the **Diagnostic** tab on the screen tab selection.

A hex code and a verbal description appears on the display as shown typically above. This is the last active diagnostic. Pressing the "Reset All Active Diagnostics" will reset all active diagnostics regardless of type, machine or refrigerant circuit. Compressor diagnostics, which hold off only one compressor, are treated as circuit diagnos-

## Controls Interface

tics, consistent with the circuit to which they belong. One circuit not operating will not shut the chiller down. Viewing the "Compressor" screen will indicate whether a circuit is not operating and for what reason.



A complete listing of diagnostics and codes is included in the Diagnostic Section.

### Power-Up

On Power-Up, DynaView will progress through three screens:

*First Screen, Version # of the Boot, full version # displayed.*

This screen will display for 5 seconds and move on to the second screen. The contrast will also be adjustable from this screen.

*Second Screen, Application or No Application.*

This screen will display for 5 seconds "A Valid Application Is Present" or "A Valid Application Is Not Present" and move on to the third screen.

*Third Screen, First screen of the Application, the Chiller Tab.*

### Display Formats

#### Units

Temperature settings are in °F or °C, depending on Display Units settings. Settings can be entered in tenths or whole degrees depending on a menu setting at the TechView.

Dashes ("—") appearing in a temperature or pressure report, indicates that the value is invalid or not applicable.

#### Languages

English plus two alternate languages may be installed with DynaView and will reside in the main processor. English will always be available. Alternate languages must be installed using TechView, Software Download View.

## TechView

Figure 37 TechView



TechView is the PC (laptop) based tool used for servicing Tracer CH530. Technicians that make any chiller control modification or service any diagnostic with Tracer CH530 must use a laptop running the software application "TechView." TechView is a Trane application developed to minimize chiller downtime and aid the technicians understanding of chiller operation and service requirements.

*NOTE: Important: Performing any Tracer CH530 service functions should be done only by a properly trained service technician. Please contact your local Trane service agency for assistance with any service requirements.*

TechView software is available via Trane.com.

(<http://www.trane.com/commercial/software/tracerch530/>)

This download site provides a user the TechView installation software and CH530 main processor software that must be loaded onto your PC in order to service a CH530 main processor. The TechView service tool is used to load software into the Tracer CH530 main processor.



# TechView

---

## Minimum PC requirements to install and operate TechView

- Pentium II or higher processor
- 128Mb RAM
- 1024 x 768 resolution of display
- 56K modem
- 9-pin RS-232 serial connection
- Operating system - Windows 2000
- Microsoft Office (MS Word, MS Access, MS Excel)
- Parallel Port (25-pin) or USB Port

*NOTE: TechView was designed for the preceding listed laptop configuration. Any variation will have unknown results. Therefore, support for TechView is limited to only those operating systems that meet the specific configuration listed here. Only computers with a Pentium II class processor or better are supported; Intel Celeron, AMD, or Cyrix processors have not been tested.*

TechView is also used to perform any CH530 service or maintenance function. Servicing a CH530 main processor includes:

- Updating main processor software
- Monitoring chiller operation
- Viewing and resetting chiller diagnostics
- Low Level Intelligent Device (LLID) replacement and binding
- Main processor replacement and configuration modifications
- Setpoint modifications
- Service overrides

## Unit View

Unit view is a summary for the system organized by chiller subsystem. This provides an overall view of chiller operating parameters and gives you an "at-a-glance" assessment of chiller operation.

The Control Panel tab displays important operating information for the unit and allows you to change several key operating parameters. The panel is divided into four or more sub-panels (depending on the number of circuits in the unit).

The Operating Mode tab displays the unit, circuit and compressor top level operating modes.

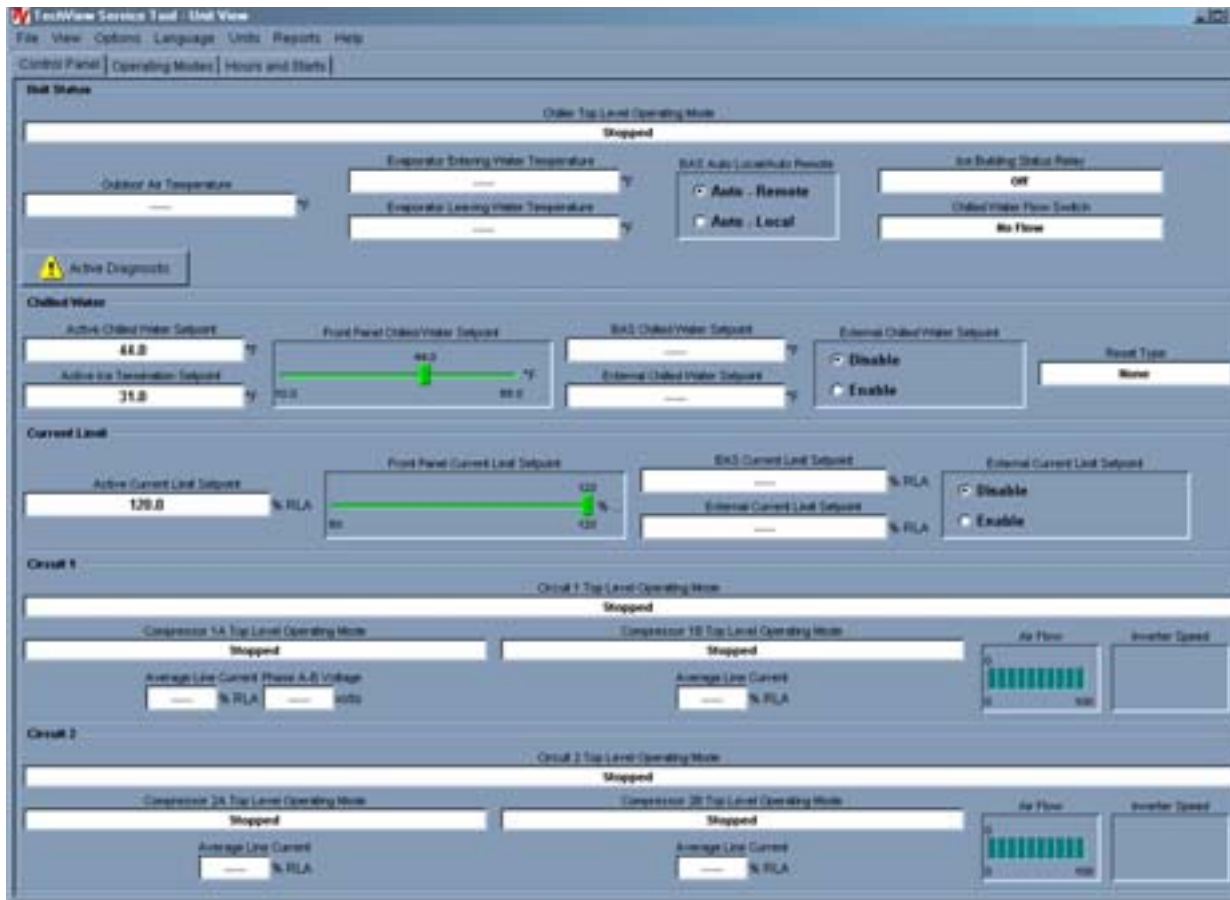
The Hours and Starts tab displays the number a hours (total) a compressor has run and the number of times the compressor has started. This window plays a key role in evaluating maintenance requirements.



# TechView

Upon successful Local Connect Tech View will display UNIT VIEW.  
RTAC Unit View is shown below

Figure 38 Unit View



# TechView

## Compressor Service View

The Compressor View provides convenient access to service functions for pumping down circuits and test starting compressors. Various operational lockouts allow operation of the rest of the chiller while some parts are awaiting repair.

Figure 39 Compressor Service View



Table 33 Compressor Service View Items

Description	Settings
Front Panel Circuit Lock Out	Locked/Unlocked
Electronic Expansion Valve	Open/Auto
Compressor Lockout	Locked/Unlocked
Compressor test	Start
Pumpdown (suction pressure is displayed)	Start/Abort

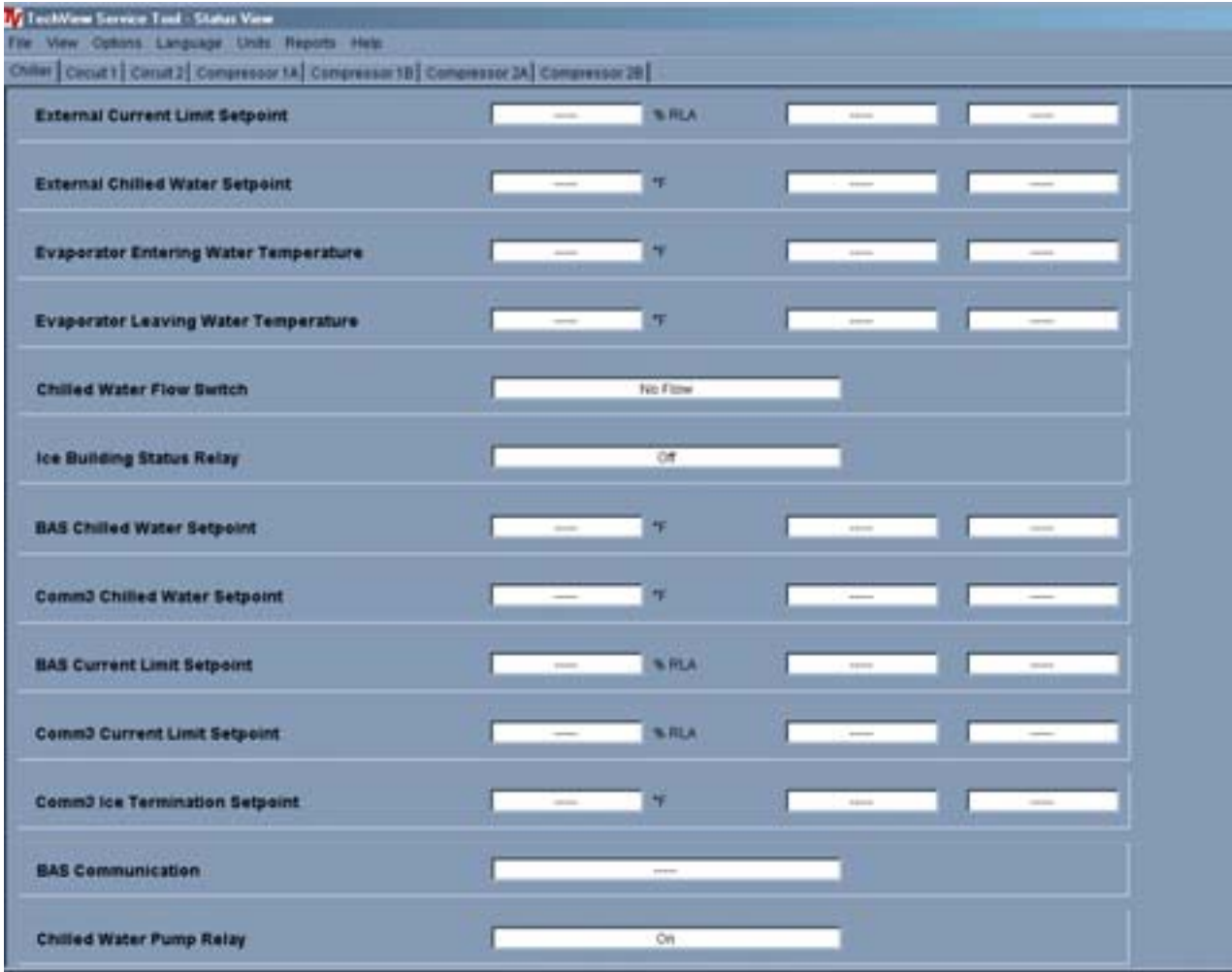


# TechView

## Status View

Status View displays, in real time, all non-setpoint data organized by subsystem tabs. As data changes on the chiller it is automatically updated in Status View.

Figure 40 Status View





# TechView

**Table 34 Status View Items**

<b>Tab</b>	<b>Text</b>	<b>Units</b>
Chiller	Chiller Top Level Operating Mode	Text
	Chiller Sub Operating Mode	Text
	Operating Mode	Text
	Chiller Sub Operating Mode	Text
	Front Panel Auto/Stop	Text
	Outdoor Air Temperature	Temperature
	External Auto/Stop	Auto/Stop
	External Emergency Stop	Auto/Stop
	Active Chilled Water Setpoint	Temperature
	Active Current Limit Setpoint	Temperature
	Active Ice Termination Setpoint	Temperature
	External Current Limit Setpoint	% RLA
	External Chilled Water Setpoint	Temperature
	Evaporator Entering Water Temperature	Temperature
	Evaporator Leaving Water Temperature	Temperature
	Chilled Water Flow Switch	Flow/NoFlow
	Ice Building Status Relay	Ice Build/Normal
	Comm3 Chilled Water Setpoint	Temperature
	BAS Chilled Water Setpoint	Temperature
	BAS Current Limit Setpoint	% RLA
	Comm3 Current Limit Setpoint	% RLA
	Comm3 Ice Termination Setpoint	Temperature
	BAS Communication	Text
Chilled Water Pump Relay	on/off	
Compressor	Compressor 1 Operating Mode	Text
	Compressor 1 Sub Mode	Text
	Compressor 1 Top Level Operating Mode	Text
	Run Hours	Integer
	Starts	Integer
	Phase A-B Voltage	Volts
	Average Line Current	Amps
	Line 1 Current	Amps
	Line 2 Current	Amps
	Line 3 Current	Amps
	Line 1 Current	% RLA
	Line 2 Current	% RLA



# TechView

**Table 34**    **Status View Items**

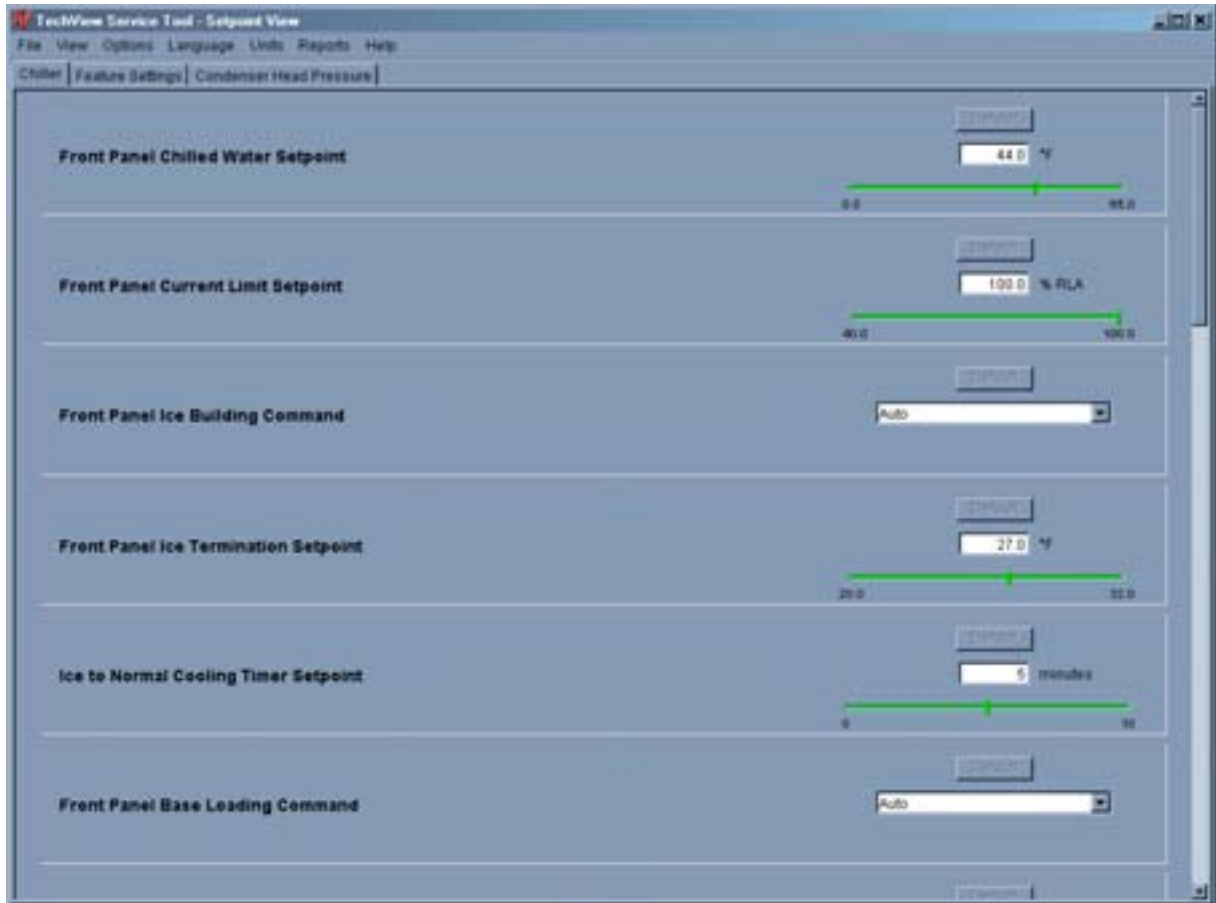
<b>Tab</b>	<b>Text</b>	<b>Units</b>
Compressor	Line 3 Current	% RLA
	Maximum Line Current	Amps
	Supply Oil Temperature	Temperature
	Intermediate Oil Pressure	Pressure
	Female Step Loader	Loaded/Unloaded
	High Pressure Cutout Switch	Tripped/Not Tripped
Circuit	Circuit Sub Mode	Text
	Circuit Top Level Operating Mode	Text
	External Hardwired Lockout	Locked/Not locked
	Front Panel Lockout	Locked/Not locked
	Air Flow	%
	Inverter Speed	% Full Speed
	Condenser Refrigerant Pressure	Pressure
	Saturated Condenser Refrigerant Temperature	Temperature
	Differential Refrigerant Pressure	Pressure
	Evaporator Refrigerant Pressure	Pressure
	Saturated Evaporator Refrigerant Temperature	Temperature
	EXV Position	% Open
	Evaporator Refrigerant Liquid Level	in

# TechView

## Setpoint View

Setpoint view displays the active setpoints and allows you to make changes.

Figure 41 Setpoint View



### Setpoint List

The center of the window displays the scrollable list of setpoint panels.

### Setpoint Enumeration Panel

A setpoint numeric panel contains a label with the setpoint description and a pull-down list showing the active value and the other selections. The Default button returns the setpoint to the product's factory setting. The text field is updated when the change is complete.

## TechView

---

### Setpoint Numeric Panel

A setpoint numeric panel contains a label with the setpoint description, a Default button, a text field with a unit label, and a slider.



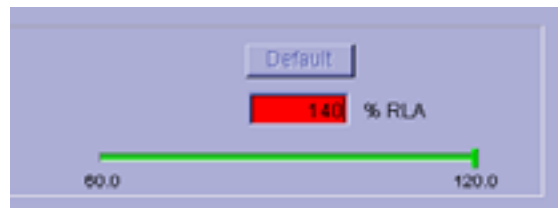
The Default button changes the setpoint to the product's factory setting. The text field and slider are updated when the change is complete.

You can change a setpoint with the text field or with the slider. When you click on the entry field, the change setpoint dialog displays to coordinate the setpoint change.

You can change the display units for a setpoint by clicking on the unit label next to the entry field.

### Change Setpoint

The change setpoint window allows you to enter a new value for the setpoint into a text field. If the entered value is outside the given range, the background turns red.



# TechView

**Table 35 Setpoints View Items**

<b>Tab</b>	<b>Text</b>	<b>Min Value</b>	<b>Max Value</b>	<b>Default Value</b>	<b>Unit Type</b>
Chiller	Front Panel Display Units	English, SI		English	Display Units
Chiller	Front Panel Chilled Water Setpoint	10 (-12.22)	65 (18.33)	44 (6.67)	Temp Deg F(C)
Chiller	Front Panel Current Limit Setpoint	60	120	120	Percent
Chiller	Differential to Stop	0.5 (0.2777)	2.5 (1.388)	2.0 (1.111)	Differential Temp Deg F(C)
Chiller	Differential to Start	1.0 (0.555)	30 (16.666)	2 (1.111)	Differential Temp Deg F(C)
Chiller	Leaving Water Temp Cutout	0.0 (-17.78)	36.0 (2.22)	36.0 (2.22)	Temp Deg F(C)
Chiller	Low Refrigerant Temp Cutout	-5.0 (-20.56)	36.0 (2.22)	28.0 (-2.22)	Temp Deg F(C)
Chiller	Front Panel Condenser Limit Setpoint	80	120	90	Percent
Chiller	Low Ambient Lockout Setpoint	-10 (-23.333)	70 (21.111)	25 (-3.89)	Temp Deg F(C)
Chiller	Low Ambient Lockout	Enable, Disable		Enable	Enabled / Disabled
Chiller	Front Panel Ice Termination Setpoint	20 (-6.67)	31 (-0.56)	31 (-0.56)	Temp Deg F(C)
Chiller	External Ice Building Input	Enable, Disable		Disable	Enabled / Disabled
Chiller	Under/Over Voltage Protection	Enable, Disable		Disable	Enabled / Disabled
Chiller	Local Atmospheric Pressure	9.93 (68.5)	16.0 (110.3)	14.7 (101.3)	Absolute Pressure psia(Kpa)
Chiller	Design Delta Temperature	4 (2.22)	30 (16.666)	10 (5.6)	Differential Temp Deg F(C)
Chiller	Reset Type	None, Return, Outdoor, Constant Return		None	RstTyp
Chiller	Return Reset Ratio	10	120	50	Percent
Chiller	Return Start Reset	4.0 (2.22)	30.0 (16.666)	10.0 (5.56)	Differential Temp Deg F(C)
Chiller	Return Maximum Reset	0	20 (11.11)	5.0 (2.78)	Differential Temp Deg F(C)
Chiller	Outdoor Reset Ratio	-80	80	10	Percent
Chiller	Outdoor Start Reset	50 (10)	130 (54.44)	90 (32.22)	Temp Deg F(C)



# TechView

**Table 35** Setpoints View Items

<b>Tab</b>	<b>Text</b>	<b>Min Value</b>	<b>Max Value</b>	<b>Default Value</b>	<b>Unit Type</b>
Chiller	Outdoor Maximum Reset	0	20 (11.11)	5 (2.78)	Differential Temp Deg F(C)
Chiller	External Chilled Water Setpoint	Enable, Disable		Disable	Enabled / Disabled
Chiller	External Current Limit Setpoint	Enable, Disable		Disable	Enabled / Disabled
Chiller	Evaporator Water Pump Off Delay	0	30	1	Minutes
Chiller	Chilled Water Setpoint Filter Settling Time	30	1800	200	Seconds
Chiller	Compressor Staging Deadband	0.4 (0.222)	4.0 (2.222)	0.05 (0.2778)	Differential Temp Deg F(C)

# TechView

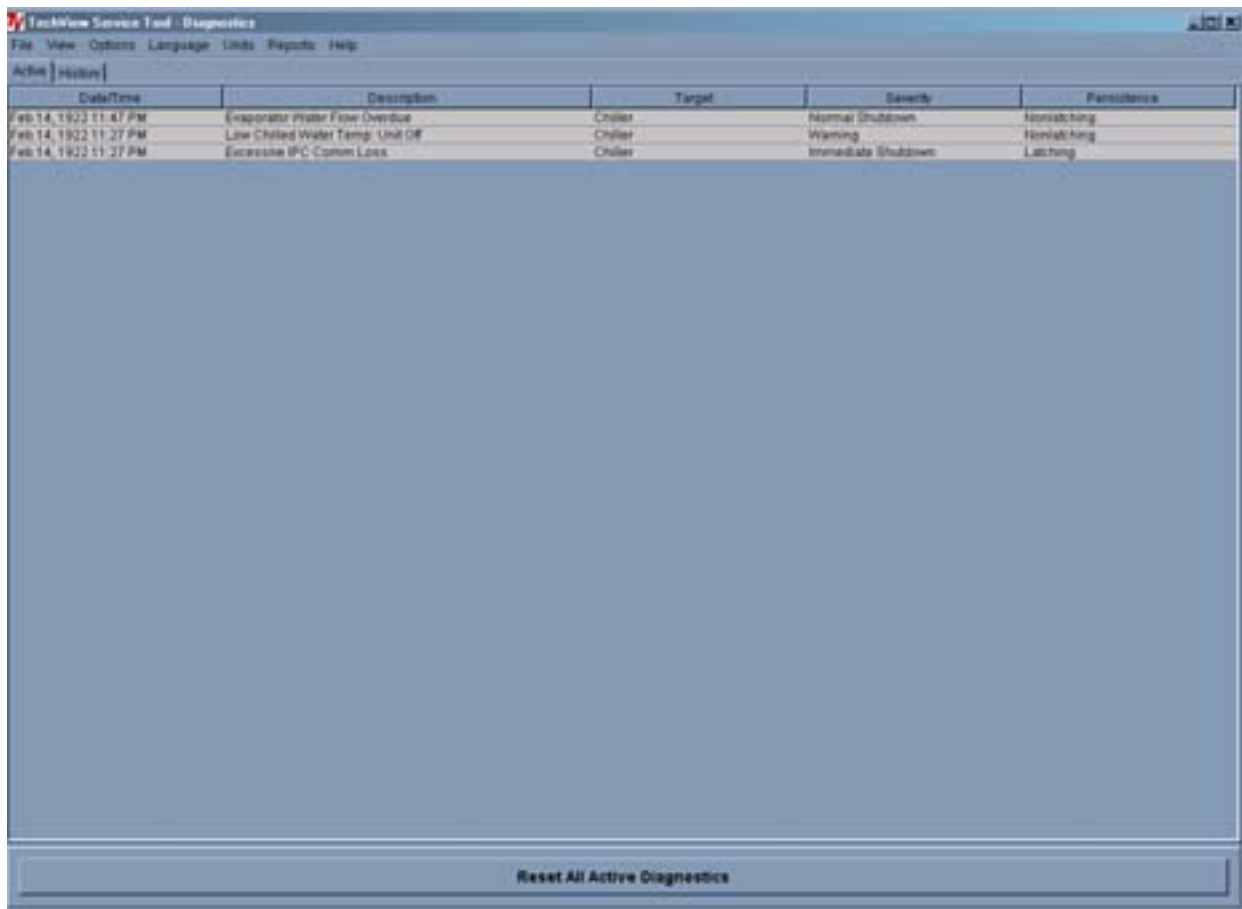
## Diagnostics View

This window lists the active and inactive (history) diagnostics. There can be up to 60 diagnostics, both active and historic. For example, if there were 5 active diagnostics, the possible number of historic diagnostics would be 55. You can also reset active diagnostics here, (i.e., transfer active diagnostics to history and allow the chiller to regenerate any active diagnostics).

Resetting the active diagnostics may cause the chiller to resume operation.

The Active and History diagnostics have separate tabs. A button to reset the active diagnostics displays when either tab is selected

Figure 42 Diagnostic View

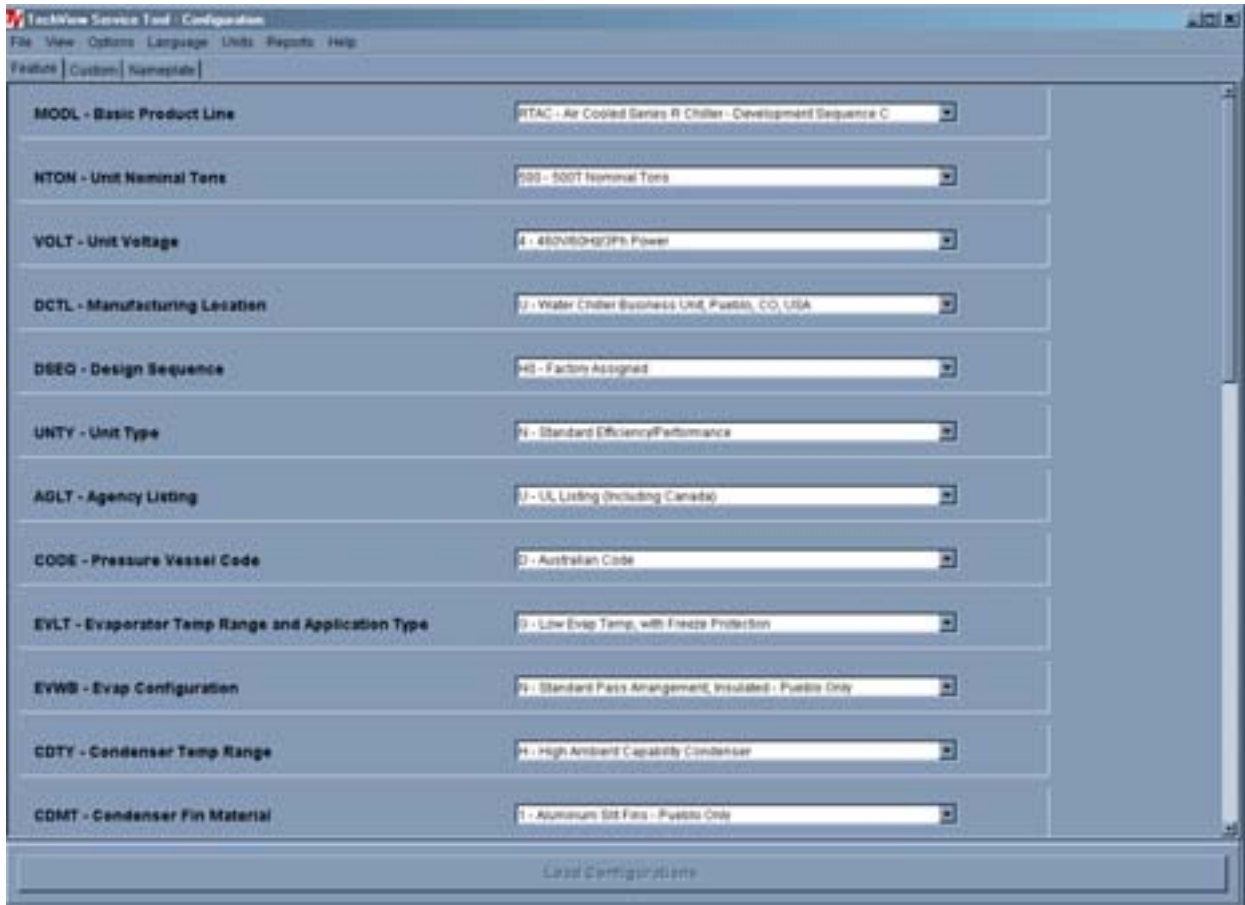


# TechView

## Configuration View

This view displays the active configuration and allows you to make changes.

Figure 43 Configuration View



Configuration View allows you to define the chiller's components, ratings, and configuration settings. These are all values that determine the required installed devices, and how the chiller application is run in the main processor. For example, a user may set an option to be installed with Configuration View, which will require devices to be bound using Binding View. And when the main processor runs the chiller application, the appropriate steps are taken to monitor required inputs and control necessary outputs.

Any changes made in the Configuration View, on any of the tabs, will modify the chiller configuration when you click on the Load Configuration button (located at the base of the window). The Load Configuration button uploads the new configuration settings into the main processor.

Any changes made to the configuration will change the unit model number and the confirmation code (CRC). If changes are made to the unit configuration the new model number and CRC should be recorded.



# TechView

Selecting the Undo All button will undo any configuration setting changes made during the present TechView connection and since the last time the Load Configuration button was selected. .

**Table 36 Configuration View Items**

Tab	Item	Default	Description
Feature	Basic Product Line		RTAC - Air Cooled Series R Chiller
	Unit Nominal Capacity		140 Nominal Tons
			155 Nominal Tons
			170 Nominal Tons
			185 Nominal Tons
			200 Nominal Tons
			225 Nominal Tons
			250 Nominal Tons
			275 Nominal Tons
			300 Nominal Tons
			350 Nominal Tons
		375 Nominal Tons	
		400 Nominal Tons	
		450 Nominal Tons	
		500 Nominal Tons	
Unit Voltage		A - 200V/60Hz/3Ph power	
		K - 220V/50Hz/3 Ph power	
		C - 230V/60Hz/3Ph power	
		J - 380V/60Hz/3Ph power	
		D - 400V/50Hz/3Ph power	
Manufacturing Location		4 - 460V/60Hz/3Ph power	
		5 - 575V/60Hz/3Ph power	
		U - Water Chiller Business Unit - Pueblo	
		E - Epinal Business Unit -Charmes	
		XX - Factory/ABU Assigned	
Design Sequence		XX - Factory/ABU Assigned	
Unit Type		N - Standard Efficiency/Performance	
		H - High Efficiency/Performance	
Agency Listing		N - No agency listing	
		U - C/UL listing	
Pressure Vessel Code		A - ASME pressure vessel code	
		C - Canadian code	
		D - Australian code	
		L - Chinese code	
		R - Vietnamese code	
		S - Special	
Evaporator Temperature Range & Application Type		F - Standard Temp. with Frz Prot	
		R - Rem Evap, Std Temp, No Frz Prot	
		G - Low Temp, with Frz Prot	
Evaporator Configuration		N - Standard pass arrangement, insulated	
Condenser Temperature Range		N - Standard ambient range 25-115 deg F	
		H - High ambient capability 25-125 deg F	
		L - Low ambient capability 0-115 deg F	
		W - Wide ambient capability 0-125 deg F	
Condenser Fin Material		1 - Standard aluminum slit fins	
		2 - Copper fins, non-slit fins	
		4 - Complete Coat aluminum fins	



# TechView

**Table 36 Configuration View Items**

Tab	Item	Default	Description
Feature	Condenser Fan/Motor Configuration		N - Condenser fans with ODP motors W - Low Noise fans T - Condenser fans with TEAO motors
	Compressor Motor Starter Type		X - Across-the-line starters Y - Wye-delta closed transition starters
	Incoming Power Line Connection		1 - Single point power connection 2 - Dual point power connection (1/ckt)
	Power Line Connection Type		T - Terminals only D - Non-fused disconnect switch(es) C - Circuit Breaker(s), HACR-rated
	Unit Operator Interface		E - Easy-View operator interface D -Dyna-View operator interface
	Remote Interface		N - No remote interface C - Tracer Comm 3 interface L -Lon Talk Communication interface (LCI)
	Control Input Accessories/Options		N -No remote input R -Remote leaving water temp stpt C -Remote current limit setpoint B -Remote lvg. temp.setpoint and remote current limit setpoint
	Control Output Accessories/Options		N -No output options A -Alarm relay C -Icemaking D -Icemaking and alarm relay
	Short Circuit Rating		0 - No short circuit withstand rating 5 -10000A SCR 4 -35000A SCR 6 -65000A SCR
	Electrical Accessories and Export Packing		N - No flow switches F - NEMA-1 flow switch - 150 psi E - Vapor Proof FS - 150 psi
	Control Panel Accessories		N - No convenience outlet A - 15A 115V convenience outlet (60HZ)
	Refrigerant Service Valves		0 - No suction services valves 1 - Suction service valves
	Compressor Sound Attenuator Option		0 - No sound attenuator 1 - Factory installed sound attenuator
	Appearance Options		N - No appearance options A - Architectural louvered panels C - Half Louvers G - Access guards B - Access guards and half louvers P - Painted unit L - Painted unit with full louvered panels H - Painted unit with half louvered panels K - Painted unit with access guards W - Painted w/access guards and half louvers

# TechView

**Table 36 Configuration View Items**

Tab	Item	Default	Description
Features	Installation Accessories		N - No installation accessories R - Neoprene Isolators F - Flanged water connection kit G - Neoprene isolators and flange wtr conn kit
	Factory Test		0 - No factory run test
	Control, Label, and Literature Language		E - English G - Chinese
	Special Order		X - Standard catalog configuration S - Unit has special order feature
Custom	Comm 3 ICD address	55	1-64 REM = C
	Status Relay #1 J2-10,11,12	Alarm - Latching	None, Alarm - Latching (Active diagnostic persistence latching), Alarm - Auto reset (Active diagnostic persistence non-latching), Alarm (Active diagnostic persistence latching or non-latching), Alarm Ckt1 (Active diagnostic persistence latching or non-latching), Alarm Ckt2 (Active diagnostic persistence latching or non-latching), Chiller Limit Mode (With 20 minute filter), Circuit 1 Running, Circuit 2 Running, Maximum Capacity COOP = A, D or X
	Status Relay #2 J2-7,8,9	Chiller Running	
	Status Relay #3 J2-4,5,6	Maximum Capacity	
	Status Relay #4 J2-1,2,3	Chiller Limit Mode	
	Phase Unbalance Trip	30	10-50%
	Phase Unbalance Grace Period	90	30-255 Sec
	Maximum Acceleration Time	3	1-255 Sec
	Starter Feature	All Enabled	Contactors Integrity Test, Phase Reversal Detect, Phase Unbalance Detect
	External Chilled Water Setpoint Detection	2-10 VDC	2-10 VDC, 4-20 mA CIOP = C or B
	External Current Limit Water Setpoint Detection	2-10 VDC	2-10 VDC, 4-20 mA CIOP = C or B
	Custom Unit Voltage	400	380,400,415 VOLT = D

Nameplate The **Model Number** field contains the model number stored in the EasyView or DynaView.

The **Confirm Code** field contains the confirm code stored in the EasyView or DynaView. The confirm code is a four-digit hex value that is a mathematical calculation of the model number. This number has one to one correlation to a specific model number and is used to verify that the model number was entered properly.

The **Serial Number** field contains the serial number stored in the EasyView or DynaView.

This model number and confirmation code must be know when the main processor requires replacement.

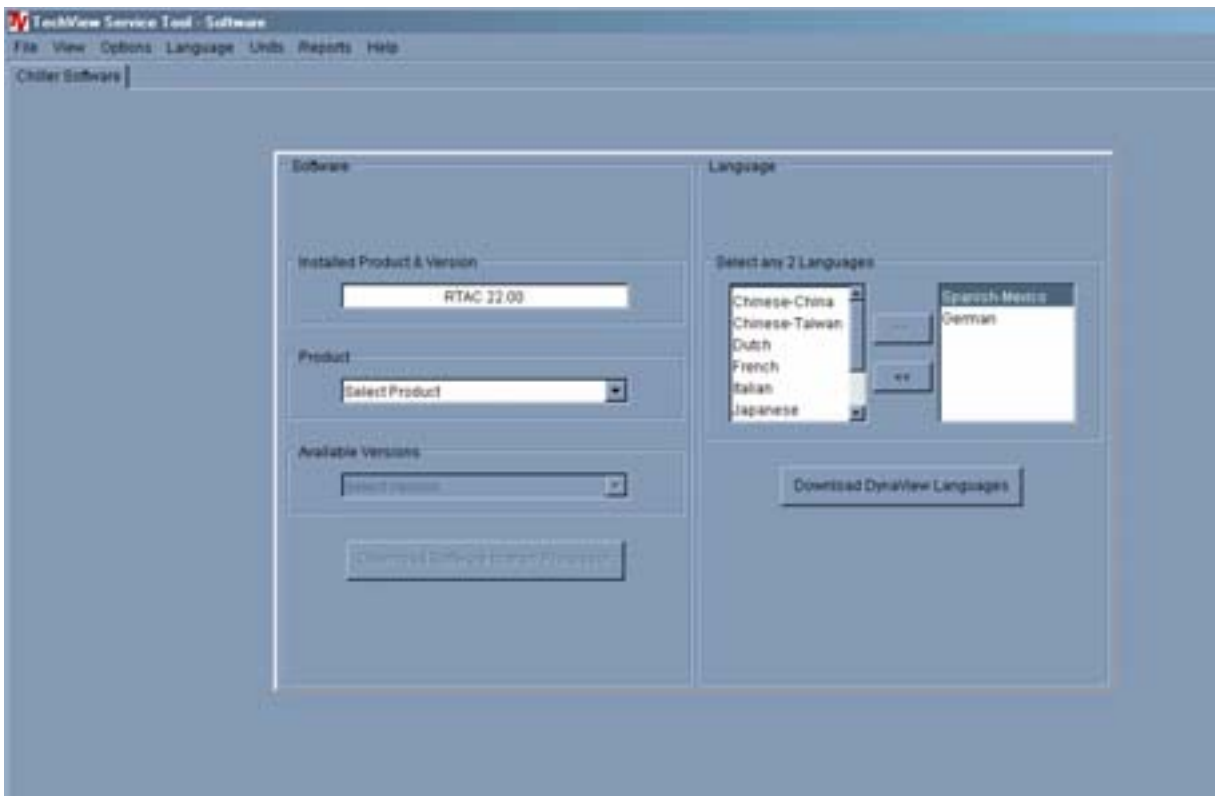
# TechView

## Software View

Software view allows you to verify the version of chiller software currently running on the EasyView or DynaView and download a new version of chiller software to the EasyView or DynaView.

You can also add up to two available languages to load into the DynaView. Loading an alternate language file allows the DynaView to display its text in the selected alternate language, English will always be available.

Figure 44 Software View



# TechView

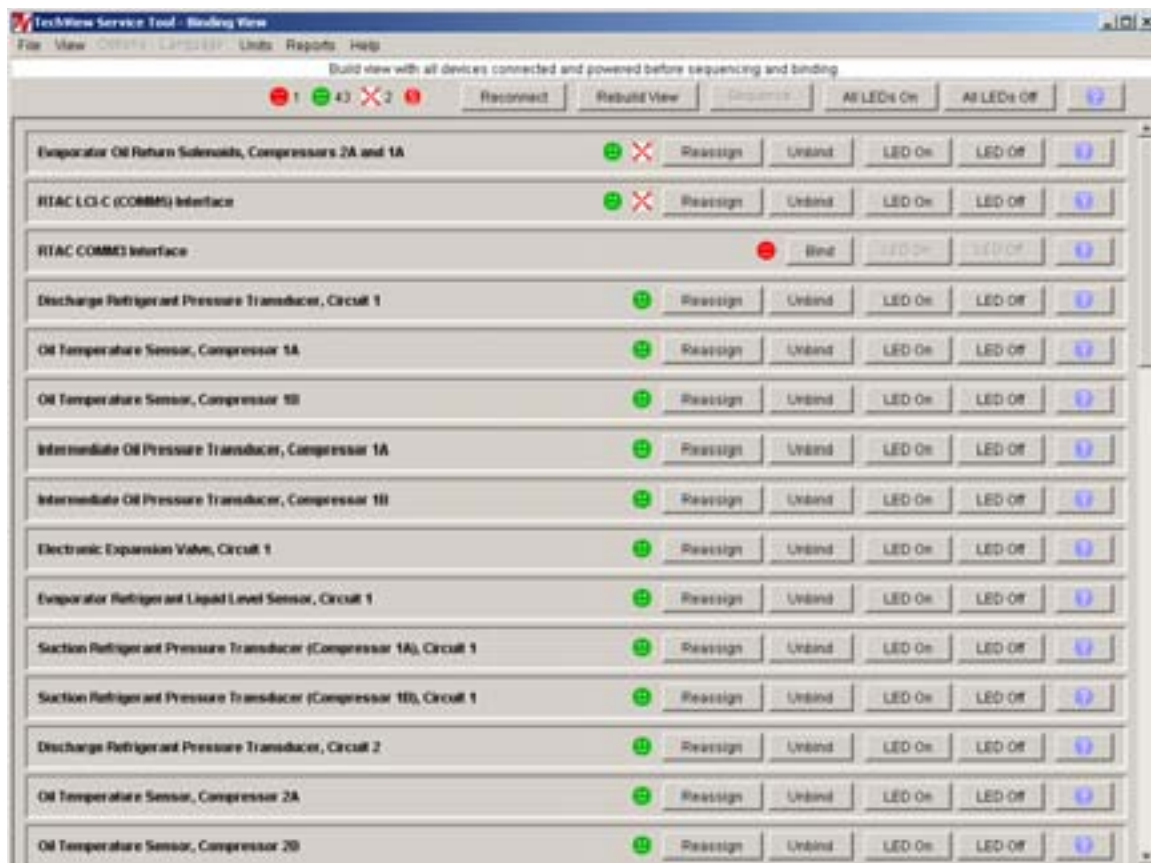
## Binding View

Binding View allows you to assess the status of the network and all the devices connected as a whole, or the status of individual devices by using status icons and function buttons.

Binding View is essentially a table depicting what devices and options are actually discovered on the network bus (and their communication status) versus what is required to support the configuration defined by the feature codes and categories. Binding View allows you to add, remove, modify, verify, and reassign devices and options in order to match the configuration requirements.

Whenever a device is installed, it must be correctly configured to communicate and to function as intended. This process is called binding. Some features of Binding View are intended to serve a second purpose; that is diagnosing problems with communication among the devices.

Figure 45 Binding View





# TechView

---

## Replacing or Adding Devices

If a device is communicating but incorrectly configured, it might not be necessary to replace it. If the problem with the device is related to communication, attempt to rebind it, and if the device becomes correctly configured, it will then communicate properly.

If a device that needs to be replaced is still communicating, it should be unbound. Otherwise, it will be necessary to rebuild the CH530 network image for Binding View to discover that it has been removed. An unbound device stops communicating and allows a new device to be bound in its place.

It is good practice to turn the power off while detaching and attaching devices to the CH530 network. Be sure to keep power on the service tool computer. After power is restored to the CH530 network, the reconnect function in Binding View restores communication with the network. If the service tool computer is turned off, you must restart TechView and Binding View.

If a device is not communicating, the binding function displays a window to request manual selection of the device to be bound. Previously-selected devices are deselected when the function starts. When manual selection is confirmed, exactly one device must be selected; if it is the correct type, it is bound. If the desired device cannot be selected or if multiple devices are accidentally selected, you can close the manual selection window by clicking on No and repeat the bind function.

## Software Download

### Instructions for First Time TechView Users

This information can also be found at <http://www.trane.com/commercial/software/tracerch530/>.

1. Create a folder called "CH530" on your C:\ drive. You will select and use this folder in subsequent steps so that downloaded files are easy to locate.
2. Download the Java Runtime installation utility file onto your PC in the CH530 folder (please note that this does not install Java Runtime, it only downloads the installation utility).
  - Click on the latest version of Java Runtime shown in the TechView Download table.
  - Select "Save this program to disk" while downloading the files (do not select "Run this program from its current location").
3. Download the TechView installation utility file onto your PC in the CH530 folder (please note that this does not install TechView, it only downloads the installation utility).
  - Click on the latest version of TechView shown in the TechView Download table.
  - Select "Save this program to disk" while downloading the files (do not select "Run this program from its current location").
4. Remember where you downloaded the files (the "CH530" folder). You will need to locate them to finish the installation process.

## TechView

---

5. Proceed to “Main Processor Software Download” page and read the instructions to download the latest version of main processor installation files.  
Note: you will first select the chiller type to obtain the available file versions.
6. Select the product family. A table with the download link will appear for that product family.
7. Download the main processor software onto your PC in the CH530 folder (please note that this does not install the main processor, it only downloads the installation utility).
  - To do this, click on the latest version of the main processor.
  - Select “Save this program to disk” while downloading the files (do not select “Run this program from its current location”).
8. Remember where you downloaded the files (the “CH530” folder). You will need to locate them to finish the installation process.
9. To complete the installation process, locate the installation utilities you downloaded into the CH530 folder. If necessary, use your PC’s file manager to locate the downloaded files.
10. Install the applications in the following order by double-clicking on the install program and following the installation prompts:
  - Java Runtime Environment (JRE\_VXXX.exe)  
Note: During the Java Runtime Environment installation, you may be prompted to “select the default Java Runtime for the system browsers...” Do not select any system browsers at this step. There should be no default browsers selected for proper operation.
  - TechView (6200-0347-VXXX.exe)
  - The main processor (6200-XXXX-XX-XX.exe).
  - The main processor program will self extract to the proper folder within the TechView program directory, provided the TechView program is properly installed on the C:\ drive.
11. Connect your PC to the CH530 main processor using a standard 9-pin male/9-pin female RS-232 cable.
12. Run the TechView software by selecting the TechView icon placed on your desktop during the installation process. The “Help...About” menu can be viewed to confirm proper installation of latest versions.



# Diagnostics

The following Diagnostic Table contains all diagnostics possible arranged alphabetically by the name assigned to each diagnostic. Not all diagnostics are available unless TechView is installed.

### Legend to Diagnostics Table

**Hex Code:** 3-digit code used to uniquely identify diagnostics.

**Diagnostic Name:** Name of the diagnostic as it appears at DynaView and/or TechView displays.

**Severity:** Defines the action of the above effect. *Immediate* means an instantaneous shutdown of the affected portion. *Normal* means routine or friendly shutdown of the affected portion. *Special Mode* means a particular mode of operation is invoked, but without shutdown, and *Info* means an Informational Note or Warning is generated.

**Persistence:** Defines whether or not the diagnostic and its effects are to be manually reset (Latched), or can be either manually or automatically reset (Nonlatched).

**Criteria:** Quantitatively defines the criteria used in generating the diagnostic and, if nonlatching, the criteria for auto reset.

**Reset Level:** Defines the lowest level of manual diagnostic reset command which can clear the diagnostic. The manual diagnostic reset levels in decreasing order of priority are: Local, Remote and Info. For example, a diagnostic that has a reset level of Remote, can be reset by either a remote diagnostic reset command or by a local diagnostic reset command, but not by the lower priority Info Reset command.

Hex Code	Diagnostic Name and Source	Severity	Persistence	Criteria	Reset Level
398	BAS Communication Lost	Special	NonLatch	The BAS was setup as "installed" at the MP and the Comm 3 LLID lost communications with the BAS for 15 contiguous minutes after it had been established. Refer to Section on Setpoint Arbitration to determine how setpoints and operating modes may be effected by the comm loss. The chiller follows the value of the Tracer Default Run Command which can be previously written by Tracer and stored nonvolatily by the MP (either use local or shutdown).	Remote
390	BAS Failed to Establish Communication	Special	NonLatch	The BAS was setup as "installed" and the BAS did not communicate with the MP within 15 minutes after power-up. Refer to Section on Setpoint Arbitration to determine how setpoints and operating modes may be effected. Note: The original requirement for this was 2 minutes, but was implemented at 15 minutes for RTAC.	Remote
2E6	Check Clock	Info	Latch	The real time clock had detected loss of its oscillator at some time in the past. This diagnostic can be effectively cleared only by writing a new value to the chiller's time clock using the TechView or DynaView's "set chiller time" functions.	Remote
8A	Chilled Water Flow (Entering Water Temperature)	Info	NonLatch	The entering evaporator water temp fell below the leaving evaporator water temp. by more than 2°F for 100 °F-sec. For RTAC this diagnostic cannot reliably indicate loss of flow, but can warn of improper flow direction through the evaporator, misbound temperature sensors, or other system problems	Remote
5EF	Comm Loss: Chilled Water Flow Switch	Immediate	Latch	Continual loss of communication between the MP and the Functional ID has occurred for a 30 second period.	Remote
5F2	Comm Loss: Cond Rfgt Pressure, Circuit #1	Immediate	Latch	Same as Comm Loss: Chilled Water Flow Switch	Remote
5F3	Comm Loss: Cond Rfgt Pressure, Circuit #2	Immediate	Latch	Same as Comm Loss: Chilled Water Flow Switch	Remote
694	Comm Loss: Electronic Expansion Valve, Circuit #1	Normal	Latch	Same as Comm Loss: Chilled Water Flow Switch	Remote
695	Comm Loss: Electronic Expansion Valve, Circuit #2	Normal	Latch	Same as Comm Loss: Chilled Water Flow Switch	Remote
5DE	Comm Loss: Emergency Stop	Normal	Latch	Same as Comm Loss: Chilled Water Flow Switch	Remote
68E	Comm Loss: Evap Oil Return Valve, Cprsr 1A	Normal	Latch	Same as Comm Loss: Chilled Water Flow Switch	Remote
69E	Comm Loss: Evap Oil Return Valve, Cprsr 1B	Normal	Latch	Same as Comm Loss: Chilled Water Flow Switch	Remote
68F	Comm Loss: Evap Oil Return Valve, Cprsr 2A	Normal	Latch	Same as Comm Loss: Chilled Water Flow Switch	Remote



# Diagnostics

Hex Code	Diagnostic Name and Source	Severity	Persis-tence	Criteria	Reset Level
69F	Comm Loss: Evap Oil Return Valve, Cprsr 2B	Normal	Latch	Same as Comm Loss: Chilled Water Flow Switch	Remote
5E4	Comm Loss: Evaporator Entering Water Temperature	Special Mode	Latch	Same as Comm Loss: Chilled Water Flow Switch	Remote
5E3	Comm Loss: Evaporator Leaving Water Temperature	Normal	Latch	Same as Comm Loss: Chilled Water Flow Switch	Remote
6BB	Comm Loss: Evaporator Rfgt Drain Valve - Ckt 1	Normal	Latch	Same as Comm Loss: Chilled Water Flow Switch	Remote
6BC	Comm Loss: Evaporator Rfgt Drain Valve - Ckt 2	Normal	Latch	Same as Comm Loss: Chilled Water Flow Switch	Remote
688	Comm Loss: Evaporator Rfgt Liquid Level, Circuit #1	Immediate	Latch	Same as Comm Loss: Chilled Water Flow Switch	Remote
689	Comm Loss: Evaporator Rfgt Liquid Level, Circuit #2	Immediate	Latch	Same as Comm Loss: Chilled Water Flow Switch	Remote
5F0	Comm Loss: Evaporator Rfgt Pressure, Circuit #1	Immediate	Latch	Continual loss of communication between the MP and the Functional ID has occurred for a 30 second period. Note: This diagnostic is replaced by diagnostic 5FB below with Rev 15.0	Remote
5F1	Comm Loss: Evaporator Rfgt Pressure, Circuit #2	Immediate	Latch	Continual loss of communication between the MP and the Functional ID has occurred for a 30 second period. Note: This diagnostic is replaced by diagnostic 5FD below with Rev 15.0	Remote
5F8	Comm Loss: Evaporator Water Pump Control	Normal	Latch	Same as Comm Loss: Chilled Water Flow Switch	Remote
5DD	Comm Loss: External Auto/ Stop	Normal	Latch	Same as Comm Loss: Chilled Water Flow Switch	Remote
5E9	Comm Loss: External Chilled Water Setpoint	Special Mode	NonLatch	Continual loss of communication between the MP and the Functional ID has occurred for a 30 second period. Chiller shall discontinue use of the External Chilled Water Setpoint source and revert to the next higher priority for setpoint arbitration	Remote
5DF	Comm Loss: External Circuit Lockout, Circuit #1	Special Mode	Latch	Continual loss of communication between the MP and the Functional ID has occurred for a 30 second period. MP will nonvolatly hold the lockout state (enabled or disabled) that was in effect at the time of comm loss.	Remote
5E0	Comm Loss: External Circuit Lockout, Circuit #2	Special Mode	Latch	Same as Comm Loss: External Circuit Lockout, Circuit #1	Remote
5EA	Comm Loss: External Current Limit Setpoint	Special Mode	NonLatch	Continual loss of communication between the MP and the Functional ID has occurred for a 30 second period. Chiller shall discontinue use of the External Current limit setpoint and revert to the next higher priority for Current Limit setpoint arbitration	Remote
680	Comm Loss: Fan Control Circuit #1, Stage #1	Normal	Latch	Same as Comm Loss: Chilled Water Flow Switch	Remote
681	Comm Loss: Fan Control Circuit #1, Stage #2	Normal	Latch	Same as Comm Loss: Chilled Water Flow Switch	Remote
682	Comm Loss: Fan Control Circuit #1, Stage #3	Normal	Latch	Same as Comm Loss: Chilled Water Flow Switch	Remote
683	Comm Loss: Fan Control Circuit #1, Stage #4	Normal	Latch	Same as Comm Loss: Chilled Water Flow Switch	Remote
684	Comm Loss: Fan Control Circuit #2, Stage #1	Normal	Latch	Same as Comm Loss: Chilled Water Flow Switch	Remote
685	Comm Loss: Fan Control Circuit #2, Stage #2	Normal	Latch	Same as Comm Loss: Chilled Water Flow Switch	Remote
686	Comm Loss: Fan Control Circuit #2, Stage #3	Normal	Latch	Same as Comm Loss: Chilled Water Flow Switch	Remote
687	Comm Loss: Fan Control Circuit #2, Stage #4	Normal	Latch	Same as Comm Loss: Chilled Water Flow Switch	Remote
68C	Comm Loss: Fan Inverter Fault, Circuit #1 or Circuit #1, Drive 1	Special Mode	Latch	Continual loss of communication between the MP and the Functional ID has occurred for a 30 second period. Operate the remaining fans as fixed speed fan deck.	Remote
68D	Comm Loss: Fan Inverter Fault, Circuit #1, Drive 2	Special Mode	Latch	Same as Comm Loss: Fan Inverter Fault, Circuit #1 or Circuit #1, Drive 1	Remote
69A	Comm Loss: Fan Inverter Fault, Circuit #2 or Circuit #2, Drive 1	Special Mode	Latch	Same as Comm Loss: Fan Inverter Fault, Circuit #1 or Circuit #1, Drive 1	Remote
69B	Comm Loss: Fan Inverter Fault, Circuit #2, Drive 2	Special Mode	Latch	Same as Comm Loss: Fan Inverter Fault, Circuit #1 or Circuit #1, Drive 1	Remote
68A	Comm Loss: Fan Inverter Power, Circuit #1 or Circuit #1 Drive 1 and 2	Normal	Latch	Same as Comm Loss: Fan Inverter Fault, Circuit #1 or Circuit #1, Drive 1	Remote



# Diagnostics

Hex Code	Diagnostic Name and Source	Severity	Persistence	Criteria	Reset Level
698	Comm Loss: Fan Inverter Power, Circuit #2 or Circuit #2 Drive 1 and 2	Normal	Latch	Same as Comm Loss: Fan Inverter Fault, Circuit #1 or Circuit #1, Drive 1	Remote
68B	Comm Loss: Fan Inverter Speed Command, Circuit #1 or Circuit #1 Drive 1 and 2	Special Mode	Latch	Same as Comm Loss: Fan Inverter Fault, Circuit #1 or Circuit #1, Drive 1	Remote
699	Comm Loss: Fan Inverter Speed Command, Circuit #2 or Circuit #2 Drive 1 and 2	Special Mode	Latch	Same as Comm Loss: Fan Inverter Fault, Circuit #1 or Circuit #1, Drive 1	Remote
5D9	Comm Loss: Female Step Load Compressor 1A	Normal	Latch	Same as Comm Loss: Chilled Water Flow Switch	Remote
5DA	Comm Loss: Female Step Load Compressor 1B	Normal	Latch	Same as Comm Loss: Chilled Water Flow Switch	Remote
5DB	Comm Loss: Female Step Load Compressor 2A	Normal	Latch	Same as Comm Loss: Chilled Water Flow Switch	Remote
5DC	Comm Loss: Female Step Load Compressor 2B	Normal	Latch	Same as Comm Loss: Chilled Water Flow Switch	Remote
5EB	Comm Loss: High Pressure Cutout Switch, Cprsr 1A	Immediate	Latch	Same as Comm Loss: Chilled Water Flow Switch	Remote
5EC	Comm Loss: High Pressure Cutout Switch, Cprsr 1B	Immediate	Latch	Same as Comm Loss: Chilled Water Flow Switch	Remote
5ED	Comm Loss: High Pressure Cutout Switch, Cprsr 2A	Immediate	Latch	Same as Comm Loss: Chilled Water Flow Switch	Remote
5EE	Comm Loss: High Pressure Cutout Switch, Cprsr 2B	Immediate	Latch	Same as Comm Loss: Chilled Water Flow Switch	Remote
5E1	Comm Loss: Ice-Machine Control	Special Mode	Latch	Continual loss of communication between the MP and the Functional ID has occurred for a 30 second period. Chiller shall revert to normal (non-ice building) mode regardless of last state.	Remote
5FA	Comm Loss: Ice-Making Status	Special Mode	Latch	Same as Comm Loss: Ice-Machine Control	Remote
5F4	Comm Loss: Intermediate Oil Pressure, Cprsr 1A	Immediate	Latch	Same as Comm Loss: Chilled Water Flow Switch	Remote
5F5	Comm Loss: Intermediate Oil Pressure, Cprsr 1B	Immediate	Latch	Same as Comm Loss: Chilled Water Flow Switch	Remote
5F6	Comm Loss: Intermediate Oil Pressure, Cprsr 2A	Immediate	Latch	Same as Comm Loss: Chilled Water Flow Switch	Remote
5F7	Comm Loss: Intermediate Oil Pressure, Cprsr 2B	Immediate	Latch	Same as Comm Loss: Chilled Water Flow Switch	Remote
69D	Comm Loss: Local BAS Interface	Special Mode	Latch	Same as Comm Loss: Chilled Water Flow Switch	Remote
5D2	Comm Loss: Male Port Load Compressor 1A	Normal	Latch	Same as Comm Loss: Chilled Water Flow Switch	Remote
5D4	Comm Loss: Male Port Load Compressor 1B	Normal	Latch	Same as Comm Loss: Chilled Water Flow Switch	Remote
5D6	Comm Loss: Male Port Load Compressor 2A	Normal	Latch	Same as Comm Loss: Chilled Water Flow Switch	Remote
5D8	Comm Loss: Male Port Load Compressor 2B	Normal	Latch	Same as Comm Loss: Chilled Water Flow Switch	Remote
5D1	Comm Loss: Male Port Unload Compressor 1A	Normal	Latch	Same as Comm Loss: Chilled Water Flow Switch	Remote
5D3	Comm Loss: Male Port Unload Compressor 1B	Normal	Latch	Same as Comm Loss: Chilled Water Flow Switch	Remote
5D5	Comm Loss: Male Port Unload Compressor 2A	Normal	Latch	Same as Comm Loss: Chilled Water Flow Switch	Remote
5D7	Comm Loss: Male Port Unload Compressor 2B	Normal	Latch	Same as Comm Loss: Chilled Water Flow Switch	Remote
5E5	Comm Loss: Oil Temperature, Circuit #1 or Cprsr 1A	Normal	Latch	Same as Comm Loss: Chilled Water Flow Switch	Remote
5E6	Comm Loss: Oil Temperature, Circuit #2 or Cprsr 2A	Normal	Latch	Same as Comm Loss: Chilled Water Flow Switch	Remote
696	Comm Loss: Oil Temperature, Cprsr 1B	Normal	Latch	Same as Comm Loss: Chilled Water Flow Switch	Remote
697	Comm Loss: Oil Temperature, Cprsr 2B	Normal	Latch	Same as Comm Loss: Chilled Water Flow Switch	Remote



# Diagnostics

Hex Code	Diagnostic Name and Source	Severity	Persis-tence	Criteria	Reset Level
5E2	Comm Loss: Outdoor Air Temperature	Normal	Latch	Continual loss of communication between the MP and the Functional ID has occurred for a 30 second period. Note that if this diagnostic occurs, operational pumpdown will be performed regardless of the last valid temperature	Remote
690	Comm Loss: Starter 1A	Immediate	Latch	Same as Comm Loss: Chilled Water Flow Switch	Local
691	Comm Loss: Starter 1B	Immediate	Latch	Same as Comm Loss: Chilled Water Flow Switch	Local
692	Comm Loss: Starter 2A	Immediate	Latch	Same as Comm Loss: Chilled Water Flow Switch	Local
693	Comm Loss: Starter 2B	Immediate	Latch	Same as Comm Loss: Chilled Water Flow Switch	Local
6AC	Comm Loss: Starter Panel High Temperature Limit - Panel 1, Cprsr 1B	Info	Latch	Same as Comm Loss: Chilled Water Flow Switch	Local
6AB	Comm Loss: Starter Panel High Temperature Limit - Panel 1, Cprsr 2A	Info	Latch	Same as Comm Loss: Chilled Water Flow Switch	Local
6AD	Comm Loss: Starter Panel High Temperature Limit - Panel 2, Cprsr 2B	Info	Latch	Same as Comm Loss: Chilled Water Flow Switch	Local
6A0	Comm Loss: Status/Annunciation Relays	Info	Latch	Same as Comm Loss: Chilled Water Flow Switch	Remote
5FB	Comm Loss: Suction Pressure Cprsr 1A	Immediate	Latch	Continual loss of communication between the MP and the Functional ID has occurred for a 30 second period. Circuit target if no isolation valves, Compressor target if isolation valves or simplex. Design Note: In the case of manifolded compressors w/o isolation valves, the occurrence of this diagnostic will also generate a comm loss with the nonexistent Suction Press Cprsr 2B in order to accomplish circuit shutdown.	Remote
5FC	Comm Loss: Suction Pressure Cprsr 1B	Immediate	Latch	Continual loss of communication between the MP and the Functional ID has occurred for a 30 second period. Design Note: For circuits with manifolded compressors w/o isolation valve option, this diagnostic will occur with the preceding diagnostic, even though this transducer is not required or installed.	Remote
5FD	Comm Loss: Suction Pressure Cprsr 2A	Immediate	Latch	Same as Comm Loss: Suction Pressure Cprsr 1A	Remote
5FE	Comm Loss: Suction Pressure Cprsr 2B	Immediate	Latch	Same as Comm Loss: Suction Pressure Cprsr 1B	Remote
2A1	Condenser Fan Variable Speed Drive Fault - Circuit 1 (Drive 1)	Special Mode	Latch	The MP has received a fault signal from the respective condenser fan Variable Speed Inverter Drive, and unsuccessfully attempted (5 times within 1 minute of each other) to clear the fault. The 4th attempt removes power from the inverter to create a power up reset. If the fault does not clear, the MP will revert to constant speed operation without the use of the inverter's fan. The inverter must be manually bypassed, and fan outputs rebound, for full fixed speed fan operation.	Remote
5B4	Condenser Fan Variable Speed Drive Fault - Circuit 1 Drive 2	Special Mode	Latch	Same as Condenser Fan Variable Speed Drive Fault - Circuit 1 (Drive 1)	Remote
2A2	Condenser Fan Variable Speed Drive Fault - Circuit 2 (Drive 1)	Special Mode	Latch	Same as Condenser Fan Variable Speed Drive Fault - Circuit 1 (Drive 1)	Remote
5B5	Condenser Fan Variable Speed Drive Fault - Circuit 2 (Drive 2)	Special Mode	Latch	Same as Condenser Fan Variable Speed Drive Fault - Circuit 1 (Drive 1)	Remote
5B8	Condenser Refrigerant Pressure Transducer - Circuit 1	Immediate	Latch	Bad Sensor or LLID	Remote
5B9	Condenser Refrigerant Pressure Transducer - Circuit 2	Immediate	Latch	Bad Sensor or LLID	Remote
FD	Emergency Stop	Immediate	Latch	EMERGENCY STOP input is open. An external interlock has tripped. Time to trip from input opening to unit stop shall be 0.1 to 1.0 seconds.	Local
8E	Evaporator Entering Water Temperature Sensor	Info	Latch	Bad Sensor or LLID a. Normal operation, no effects on control. b. Chiller shall remove any Return or Constant Return Chilled Water Reset, if it was in effect. Apply slew rates per Chilled Water Reset spec.	Remote
AB	Evaporator Leaving Water Temperature Sensor	Normal	Latch	Bad Sensor or LLID	Remote
27D	Evaporator Liquid Level Sensor - Circuit 1	Immediate	Latch	Bad Sensor or LLID	Remote
3F9	Evaporator Liquid Level Sensor - Circuit 2	Immediate	Latch	Bad Sensor or LLID	Remote



# Diagnostics

Hex Code	Diagnostic Name and Source	Severity	Persistence	Criteria	Reset Level
6B9	Evaporator Rfght Drain - Circuit 1	NA	Latch	This diagnostic is effective only with Remote Evap units. The liquid level of the respective evaporator was not seen to be below the level of -21.2 mm (0.83 in) within 5 minutes of the commanded opening of its Drain Valve Solenoid. The diagnostic will not be active if the drain valve is commanded closed.	Remote
6BA	Evaporator Rfght Drain - Circuit 2	NA	Latch	Same as Evaporator Rfght Drain - Circuit 1	Remote
ED	Evaporator Water Flow Lost	Immediate	NonLatch	a. The chilled water flow switch input was open for more than 6-10 contiguous seconds. b. This diagnostic does not de-energize the evap pump output c. 6-10 seconds of contiguous flow shall clear this diagnostic. d. Even though the pump times out in the STOP modes, this diagnostic shall not be called out in the STOP modes. Note that this diagnostic will not light the red diagnostic light on the Easy View display.	Remote
384	Evaporator Water Flow Overdue	Normal	NonLatch	Evaporator water flow was not proven within 4.25 minutes (RTAC Rev 20 and earlier) or 20 minutes (RTAC Rev 21) of the Chilled water pump relay being energized. With SW Rev 17.0 and earlier, the diagnostic will de-energize the Chilled Water Pump output. It will be re-energized if the diagnostic clears with the return of flow and the chiller will be allowed to restart normally (to accommodate external control of pump) With SW Rev 18.0 and later, the pump command status will not be effected. Note that this diagnostic will not light the red diagnostic light on the EasyView display.	Remote
5C4	Excessive Loss of Comm	Immediate	Latch	Loss of comm with 75% or more of the LLIDs configured for the system has been detected. This diagnostic will suppress the callout of all subsequent comm loss diagnostics. Check power supply(s) and power disconnects - troubleshoot LLIDS buss using TechView	Remote
87	External Chilled Water Setpoint	Info	NonLatch	a. Function Not "Enabled": no diagnostics. b. "Enabled ": Out-Of-Range Low or Hi or bad LLID, set diagnostic, default CWS to next level of priority (e.g. Front Panel SetPoint). This Info diagnostic will automatically reset if the input returns to the normal range.	Remote
89	External Current Limit Setpoint	Info	NonLatch	Same as External Chilled Water Setpoint	Remote
1C6	High Differential Refrigerant Pressure - Circuit 1	Normal	Latch	The system differential pressure for the respective circuit was above 275 Psid for 2 consecutive samples or more than 10 seconds.	Remote
1C7	High Differential Refrigerant Pressure - Circuit 2	Normal	Latch	Same as High Differential Refrigerant Pressure - Circuit 1	Remote
584	High Evaporator Liquid Level - Circuit 1	Normal	Latch	The liquid level sensor is seen to be at or near its high end of range for 80 contiguous minutes while the compressor is running. (The diagnostic timer will hold, but not clear when the circuit is off). Design: 80% or more of bit count corresponding to +21.2 mm or more liquid level for 80 minutes)	Remote
5B7	High Evaporator Liquid Level - Circuit 2	Normal	Latch	Same as High Evaporator Liquid Level - Circuit 1	Remote
6B8	High Evaporator Refrigerant Pressure	Immediate	NonLatch	The evaporator refrigerant pressure of either circuit has risen above 190 psig. The evaporator water pump relay will be de-energized to stop the pump regardless of why the pump is running. The diagnostic will auto reset and the pump will return to normal control when all of the evaporator pressures fall below 185 psig. This diagnostic has severity of Immediate because if an evaporator pressure reads high without being invalid, the pump would be shut off but the chiller could keep running. Evap water flow diagnostics are not active if the pump is commanded off, only if the pump is commanded on but flow does not occur as expected.	Remote
1DE	High Oil Temperature - Compressor 1A	Immediate	Latch	The respective oil temperature as supplied to the compressor, exceeded 200°F for 2 consecutive samples or for over 10 seconds. Note: As part of the Compressor High Temperature Limit Mode (aka Minimum Limit), the running compressor's female load step will be forced loaded when its oil temperature exceeds 190F and returned to normal control when the oil temperature falls below 170°F.	Remote
1E0	High Oil Temperature - Compressor 1B	Immediate	Latch	Same as High Oil Temperature - Compressor 1A	Remote
1DD	High Oil Temperature - Compressor 2A	Immediate	Latch	Same as High Oil Temperature - Compressor 1A	Remote
1DF	High Oil Temperature - Compressor 2B	Immediate	Latch	Same as High Oil Temperature - Compressor 1A	Remote
F5	High Pressure Cutout - Compressor 1A	Immediate	Latch	A high pressure cutout was detected on Compressor 1A; trip at 315 ± 5 PSIG. Note: Other diagnostics that may occur as an expected consequence of the HPC trip will be suppressed from annunciation. These include Phase Loss, Power Loss, and Transition Complete Input Open.	Local
F6	High Pressure Cutout - Compressor 1B	Immediate	Latch	Same as High Pressure Cutout - Compressor 1A	Local



# Diagnostics

Hex Code	Diagnostic Name and Source	Severity	Persis-tence	Criteria	Reset Level
BE	High Pressure Cutout - Compressor 2A	Immediate	Latch	Same as High Pressure Cutout - Compressor 1A	Local
BF	High Pressure Cutout - Compressor 2B	Immediate	Latch	Same as High Pressure Cutout - Compressor 1A	Local
5BE	Intermediate Oil Pressure Transducer - Compressor 1A	Immediate	Latch	Bad Sensor or LLID	Remote
5BF	Intermediate Oil Pressure Transducer - Compressor 1B	Immediate	Latch	Bad Sensor or LLID	Remote
5C0	Intermediate Oil Pressure Transducer - Compressor 2A	Immediate	Latch	Bad Sensor or LLID	Remote
5C1	Intermediate Oil Pressure Transducer - Compressor 2B	Immediate	Latch	Bad Sensor or LLID	Remote
C5	Low Chilled Water Temp: Unit Off	Special Mode	NonLatch	The leaving chilled water temp. fell below the leaving water temp cutout setting for 30 degree F seconds while the Chiller is in the Stop mode, or in Auto mode with no compressors running. Energize Evap Water pump Relay until diagnostic auto resets, then return to normal evap pump control. Automatic reset occurs when the temp rises 2°F (1.1°C) above the cutout setting for 30 minutes.	Remote
C6	Low Chilled Water Temp: Unit On	Immediate and Special Mode	NonLatch	The chilled water temp. fell below the cutout setpoint for 30 degree F Seconds while the compressor was running. Automatic reset occurs when the temperature rises 2 °F (1.1°C) above the cutout setting for 2 minutes. This diagnostic shall not de-energize the Evaporator Water Pump Output.	Remote
1AE	Low Differential Refrigerant Pressure - Circuit 1	Immediate	Latch	The system differential pressure for the respective circuit was below 35 Psid for more than 2000 Psid-sec with either a 1 minute (single cprsr circuit) or 2.5 minute (manifolded cprsr circuit) ignore time from the start of the circuit.	Remote
1AF	Low Differential Refrigerant Pressure - Circuit 2	Immediate	Latch	Same as Low Differential Refrigerant Pressure - Circuit 1	Remote
583	Low Evaporator Liquid Level - Circuit 1	Info	NonLatch	The liquid level sensor is seen to be at or near its low end of range for 80 contiguous minutes while the compressor is running. Design: 20% or less of bit count corresponding to -21.2 mm or less liquid level for 80 minutes)	Remote
5B6	Low Evaporator Liquid Level - Circuit 2	Info	NonLatch	Same as Low Evaporator Liquid Level - Circuit 1	Remote
194	Low Evaporator Refrigerant Temperature - Circuit 1	Immediate	Latch	a. The inferred Saturated Evap Refrigerant Temperature (calculated from suction pressure transducer(s)) dropped below the Low Refrigerant Temperature Cutout Setpoint for 120°F-sec (8°F-sec max rate) while the circuit was running after the ignore period had expired. The integral is held at zero for the ignore time (which is a function of outdoor air temp) following the circuit startup and the integral will be limited to never trip in less than 15 seconds, i.e. the error term shall be clamped to 8°F. The minimum LRTC setpoint is -5°F (18.7 Psia) the point at which oil separates from the refrigerant. b. During the timeout of the trip integral, the unload solenoid(s) of the running compressors on the circuit, shall be energized continuously. Normal load/unload operation will be resumed if the trip integral is reset by return to temps above the cutout setpoint.	Remote
195	Low Evaporator Refrigerant Temperature - Circuit 2	Immediate	Latch	Same as Low Evaporator Refrigerant Temperature - Circuit 1	Remote
6B3	Low Evaporator Temp - Ckt 1: Unit Off	Special Mode	NonLatch	Any of the evap sat temps fell below the water temp cutout setting while the respective evap liquid level was greater than -21.2mm for 30 degree F seconds while Chiller is in the Stop mode, or in Auto mode with no compressors running. Energize Evap Water pump Relay until diagnostic auto resets, then return to normal evap pump control. Automatic reset occurs when either the evap temp rises 2°F (1.1°C) above the cutout setting or the liquid level falls below -21.2mm for 30 minutes	Remote
6B3	Low Evaporator Temp - Ckt 2: Unit Off	Special Mode	NonLatch	Same as Low Evaporator Temp - Ckt 1: Unit Off	Remote
198	Low Oil Flow - Compressor 1A	Immediate	Latch	The intermediate oil pressure transducer for this compressor was out of the acceptable pressure range for 15 seconds, while the Delta Pressure was greater than 35 Psid.; Acceptable range is $0.50 > (PC-PI) / (PC-PE)$ for the first 2.5 minutes of operation, and $0.25 > (PC-PI) / (PC-PE)$ thereafter,	Local
199	Low Oil Flow - Compressor 1B	Immediate	Latch	Same as Low Oil Flow - Compressor 1A	Local
19A	Low Oil Flow - Compressor 2A	Immediate	Latch	Same as Low Oil Flow - Compressor 1A	Local
19B	Low Oil Flow - Compressor 2B	Immediate	Latch	Same as Low Oil Flow - Compressor 1A	Local



# Diagnostics

Hex Code	Diagnostic Name and Source	Severity	Persis-tence	Criteria	Reset Level
B5	Low Suction Refrigerant Pressure - Circuit 1	Immediate	Latch	a. The Suction Refrigerant Pressure (or either of the compressor suction pressures) dropped below 10 Psia just prior to compressor start (after EXV preposition). b. The pressure fell below 16 Psia while running after the ignore time had expired, or fell below 10 Psia (or 5 Psia in software prior to Oct'02) before the ignore time had expired. The ignore time is function of outdoor air temperature. Note: Part b. is identical to Low Evaporator Refrigerant Temperature diagnostic except for the trip integral and trip point settings.	Local
B6	Low Suction Refrigerant Pressure - Circuit 2	Immediate	Latch	Same as Low Suction Refrigerant Pressure - Circuit 1	Local
B7	Low Suction Refrigerant Pressure - Cprsr 1B	Immediate	Latch	Same as Low Suction Refrigerant Pressure - Circuit 1	Local
B8	Low Suction Refrigerant Pressure - Cprsr 2B	Immediate	Latch	Same as Low Suction Refrigerant Pressure - Circuit 1	Local
BA	Motor Current Overload - Compressor 1A	Immediate	Latch	Compressor current exceeded overload time vs. trip characteristic. For A/C products Must trip = 140% RLA, Must hold=125%, nominal trip 132.5% in 30 seconds	Local
BB	Motor Current Overload - Compressor 1B	Immediate	Latch	Same as Motor Current Overload - Compressor 1A	Local
BC	Motor Current Overload - Compressor 2A	Immediate	Latch	Same as Motor Current Overload - Compressor 1A	Local
BD	Motor Current Overload - Compressor 2B	Immediate	Latch	Same as Motor Current Overload - Compressor 1A	Local
1AD	MP Application Memory CRC Error	Immediate	Latch	Memory error criteria TBD	Remote
6A1	MP: Could not Store Starts and Hours	Info	Latch	MP has determined there was an error with the previous power down store. Starts and Hours may have been lost for the last 24 hours.	Remote
5FF	MP: Invalid Configuration	Immediate	Latch	MP has an invalid configuration based on the current software installed	Remote
6A2	MP: Non-Volatile Block Test Error	Info	Latch	MP has determined there was an error with a block in the Non-Volatile memory. Check settings.	Remote
69C	MP: Non-Volatile Memory Reformat	Info	Latch	MP has determined there was an error in a sector of the Non-Volatile memory and it was reformatted. Check settings.	Remote
D9	MP: Reset Has Occurred	Info	NonLatch	The main processor has successfully come out of a reset and built its application. A reset may have been due to a power up, installing new software or configuration. This diagnostic is immediately and automatically cleared and thus can only be seen in the Historic Diagnostic List in TechView	Remote
1E1	Oil Flow Fault - Compressor 1A	Immediate	Latch	The Intermediate Oil Pressure Transducer for this cprsr is reading a pressure either above its respective circuit's Condenser Pressure by 15 Psia or more, , or below its respective Suction Pressure 10 Psia or more for 30 seconds continuously.	Local
1E2	Oil Flow Fault - Compressor 1B	Immediate	Latch	Same as Oil Flow Fault - Compressor 1A	Local
5A0	Oil Flow Fault - Compressor 2A	Immediate	Latch	Same as Oil Flow Fault - Compressor 1A	Local
5A1	Oil Flow Fault - Compressor 2B	Immediate	Latch	Same as Oil Flow Fault - Compressor 1A	Local
1E6	Oil Temperature Sensor - Cprsr 1B	Normal	Latch	Bad Sensor or LLID	Remote
1E8	Oil Temperature Sensor - Cprsr 2B	Normal	Latch	Bad Sensor or LLID	Remote
1E5	Oil Temperature Sensor -Cprsr 1A	Normal	Latch	Bad Sensor or LLID	Remote
1E7	Oil Temperature Sensor -Cprsr 2A	Normal	Latch	Bad Sensor or LLID	Remote
A1	Outdoor Air Temperature Sensor	Normal	Latch	Bad Sensor or LLID. Note that if this diagnostic occurs, operational pumpdown will be performed regardless of the last valid temperature	Remote
D7	Over Voltage	Normal	NonLatch	a. Line voltage above + 10% of nominal. [Must hold = + 10 % of nominal. Must trip = + 15 % of nominal. Reset differential = min. of 2% and max. of 4%. Time to trip = minimum of 1 min. and maximum of 5 min.] Design: Nom. trip: 60 seconds at greater than 112.5%, + or - 2.5%, Auto Reset at 109% or less.	Remote
19C	Phase Loss - Compressor 1A	Immediate	Latch	a) No current was sensed on one or two of the current transformer inputs while running or starting (See Nonlatching Power Loss Diagnostic for all three phases lost while running). Must hold = 20% RLA. Must trip = 5% RLA. Time to trip shall be longer than guaranteed reset on Starter Module at a minimum, 3 seconds maximum. Actual design trippoint is 10%. The actual design trip time is 2.64 seconds. b) If Phase reversal protection is enabled and current is not sensed on one or more current xformer inputs. Logic will detect and trip in a maximum of 0.3 second from compressor start.	Local



# Diagnostics

Hex Code	Diagnostic Name and Source	Severity	Persistence	Criteria	Reset Level
19D	Phase Loss - Compressor 1B	Immediate	Latch	Same as Phase Loss - Compressor 1A	Local
19E	Phase Loss - Compressor 2A	Immediate	Latch	Same as Phase Loss - Compressor 1A	Local
19F	Phase Loss - Compressor 2B	Immediate	Latch	Same as Phase Loss - Compressor 1A	Local
184	Phase Reversal - Compressor 1A	Immediate	Latch	A phase reversal was detected on the incoming current. On a compressor startup the phase reversal logic must detect and trip in a maximum of .3 second from compressor start.	Local
185	Phase Reversal - Compressor 1B	Immediate	Latch	Same as Phase Reversal - Compressor 1A	Local
186	Phase Reversal - Compressor 2A	Immediate	Latch	Same as Phase Reversal - Compressor 1A	Local
187	Phase Reversal - Compressor 2B	Immediate	Latch	Same as Phase Reversal - Compressor 1A	Local
1A0	Power Loss - Compressor 1A	Immediate	NonLatch	The compressor had previously established currents while running and then all three phases of current were lost. Design: Less than 10% RLA, trip in 2.64 seconds. This diagnostic will preclude the Phase Loss Diagnostic and the Transition Complete Input Opened Diagnostic from being called out. To prevent this diagnostic from occurring with the intended disconnect of main power, the minimum time to trip must be greater than the guaranteed reset time of the Starter module. Note: This diagnostic prevents nuisance latching diagnostics due to a momentary power loss - It does not protect motor/compressor from uncontrolled power reapplication. See Momentary Power Loss Diagnostic for this protection. This diagnostic is not active during the start mode before the transition complete input is proven. Thus a random power loss during a start would result in either a "Starter Fault Type 3" or a "Starter Did Not Transition" latching diagnostic.	Remote
1A1	Power Loss - Compressor 1B	Immediate	NonLatch	Same as Power Loss - Compressor 1A	Remote
1A2	Power Loss - Compressor 2A	Immediate	NonLatch	Same as Power Loss - Compressor 1A	Remote
1A3	Power Loss - Compressor 2B	Immediate	NonLatch	Same as Power Loss - Compressor 1A	Remote
8C	Pumpdown Terminated - Circuit 1	Info	NonLatch	The pumpdown cycle for this circuit was terminated abnormally due to excessive time or due to a specific set of diagnostic criteria - but w/o associated latching diagnostics	Remote
8D	Pumpdown Terminated - Circuit 2	Info	NonLatch	Same as Pumpdown Terminated - Circuit 1	Remote
1B2	Severe Current Imbalance - Compressor 1A	Immediate	Latch	A 30% Current Imbalance has been detected on one phase relative to the average of all 3 phases for 90 continuous seconds.	Local
1B3	Severe Current Imbalance - Compressor 1B	Immediate	Latch	Same as Severe Current Imbalance - Compressor 1A	Local
1B4	Severe Current Imbalance - Compressor 2A	Immediate	Latch	Same as Severe Current Imbalance - Compressor 1A	Local
1B5	Severe Current Imbalance - Compressor 2B	Immediate	Latch	Same as Severe Current Imbalance - Compressor 1A	Local
5CD	Starter 1A Comm Loss: MP	Immediate	Latch	Starter has had a loss of communication with the MP for a 15 second period.	Local
6A7	Starter 1A Dry Run Test	Immediate	Latch	While in the Starter Dry Run Mode either 50 % Line Voltage was sensed at the Potential Transformers or 10 % RLA Current was sensed at the Current Transformers.	Local
5CE	Starter 1B Comm Loss: MP	Immediate	Latch	Starter has had a loss of communication with the MP for a 15 second period.	Local
6A8	Starter 1B Dry Run Test	Immediate	Latch	While in the Starter Dry Run Mode either 50 % Line Voltage was sensed at the Potential Transformers or 10 % RLA Current was sensed at the Current Transformers.	Local
5CF	Starter 2A Comm Loss: MP	Immediate	Latch	Starter has had a loss of communication with the MP for a 15 second period.	Local
6A9	Starter 2A Dry Run Test	Immediate	Latch	While in the Starter Dry Run Mode either 50 % Line Voltage was sensed at the Potential Transformers or 10 % RLA Current was sensed at the Current Transformers.	Local
5D0	Starter 2B Comm Loss: MP	Immediate	Latch	Starter has had a loss of communication with the MP for a 15 second period.	Local
6AA	Starter 2B Dry Run Test	Immediate	Latch	While in the Starter Dry Run Mode either 50 % Line Voltage was sensed at the Potential Transformers or 10 % RLA Current was sensed at the Current Transformers.	Local



# Diagnostics

Hex Code	Diagnostic Name and Source	Severity	Persistence	Criteria	Reset Level
CC	Starter Contactor Interrupt Failure - Compressor 2A	Special Mode	Latch	Detected compressor currents greater than 10% RLA on any or all phases when the compressor was commanded off. Detection time shall be 5 second minimum and 10 seconds maximum. On detection and until the controller is manually reset: generate diagnostic, energize the appropriate alarm relay, continue to energize the Evap Pump Output, continue to command the affected compressor off, fully unload the effected compressor and command a normal stop to all other compressors. For as long as current continues, perform liquid level and fan control on the circuit effected.	Local
CA	Starter Contactor Interrupt Failure - Compressor 1A	Special Mode	Latch	Same as Starter Contactor Interrupt Failure - Compressor 2A	Local
CB	Starter Contactor Interrupt Failure - Compressor 1B	Special Mode	Latch	Same as Starter Contactor Interrupt Failure - Compressor 2A	Local
CD	Starter Contactor Interrupt Failure - Compressor 2B	Special Mode	Latch	Same as Starter Contactor Interrupt Failure - Compressor 2A	Local
180	Starter Did Not Transition - Compressor 1A	Immediate	Latch	The Starter Module did not receive a transition complete signal in the designated time from its command to transition. The must hold time from the Starter Module transition command is 1 second. The Must trip time from the transition command is 6 seconds. Actual design is 2.5 seconds. This diagnostic is active only for Y-Delta, Auto-Transformer, Primary Reactor, and X-Line Starters.	Local
181	Starter Did Not Transition - Compressor 1B	Immediate	Latch	Same as Starter Did Not Transition - Compressor 1A	Local
182	Starter Did Not Transition - Compressor 2A	Immediate	Latch	Same as Starter Did Not Transition - Compressor 1A	Local
183	Starter Did Not Transition - Compressor 2B	Immediate	Latch	Same as Starter Did Not Transition - Compressor 1A	Local
6A3	Starter Failed to Arm/Start - Cprsr 1A	Info	Latch	Starter failed to arm or start within the allotted time (15 seconds).	Local
6A4	Starter Failed to Arm/Start - Cprsr 1B	Info	Latch	Same as Starter Failed to Arm/Start - Cprsr 1A	Local
6A5	Starter Failed to Arm/Start - Cprsr 2A	Info	Latch	Same as Starter Failed to Arm/Start - Cprsr 1A	Local
6A6	Starter Failed to Arm/Start - Cprsr 2B	Info	Latch	Same as Starter Failed to Arm/Start - Cprsr 1A	Local
1E9	Starter Fault Type I - Compressor 1A	Immediate	Latch	This is a specific starter test where 1M(1K1) is closed first and a check is made to ensure that there are no currents detected by the CT's. If currents are detected when only 1M is closed first at start, then one of the other contactors is shorted.	Local
1EA	Starter Fault Type I - Compressor 1B	Immediate	Latch	Same as Starter Fault Type I - Compressor 1A	Local
1EB	Starter Fault Type I - Compressor 2A	Immediate	Latch	Same as Starter Fault Type I - Compressor 1A	Local
1EC	Starter Fault Type I - Compressor 2B	Immediate	Latch	Same as Starter Fault Type I - Compressor 1A	Local
1ED	Starter Fault Type II - Compressor 1A	Immediate	Latch	a. This is a specific starter test where the Shorting Contactor (1K3) is individually energized and a check is made to ensure that there are no currents detected by the CT's. If current is detected when only S is energized at Start, then 1M is shorted. b. This test in a. above applies to all forms of starters (Note: It is understood that many starters do not connect to the Shorting Contactor.).	Local
1EE	Starter Fault Type II - Compressor 1B	Immediate	Latch	Same as Starter Fault Type II - Compressor 1A	Local
1EF	Starter Fault Type II - Compressor 2A	Immediate	Latch	Same as Starter Fault Type II - Compressor 1A	Local
1F0	Starter Fault Type II - Compressor 2B	Immediate	Latch	Same as Starter Fault Type II - Compressor 1A	Local
1F1	Starter Fault Type III - Compressor 1A	Immediate	Latch	As part of the normal start sequence to apply power to the compressor, the Shorting Contactor (1K3) and then the Main Contactor (1K1) were energized. 1.6 seconds later there were no currents detected by the CT's for the last 1.2 Seconds on all three phases. The test above applies to all forms of starters except Adaptive Frequency Drives.	Local
1F2	Starter Fault Type III - Compressor 1B	Immediate	Latch	Same as Starter Fault Type III - Compressor 1A	Local
1F3	Starter Fault Type III - Compressor 2A	Immediate	Latch	Same as Starter Fault Type III - Compressor 1A	Local
1F4	Starter Fault Type III - Compressor 2B	Immediate	Latch	Same as Starter Fault Type III - Compressor 1A	Local
5C7	Starter Module Memory Error Type 1 - Starter 2A	Info	Latch	Checksum on RAM copy of the Starter LLID configuration failed. Configuration recalled from EEPROM.	Local



# Diagnostics

Hex Code	Diagnostic Name and Source	Severity	Persistence	Criteria	Reset Level
5C8	Starter Module Memory Error Type 1 - Starter 2B	Info	Latch	Same as Starter Module Memory Error Type 1 - Starter 2A	Local
5C5	Starter Module Memory Error Type 1 Starter 1A	Info	Latch	Same as Starter Module Memory Error Type 1 - Starter 2A	Local
5C6	Starter Module Memory Error Type 1-Starter 1B	Info	Latch	Same as Starter Module Memory Error Type 1 - Starter 2A	Local
5C9	Starter Module Memory Error Type 2 - Starter 1A	Immediate	Latch	Same as Starter Module Memory Error Type 1 - Starter 2A	Local
5CA	Starter Module Memory Error Type 2 - Starter 1B	Immediate	Latch	Same as Starter Module Memory Error Type 1 - Starter 2A	Local
5CB	Starter Module Memory Error Type 2 - Starter 2A	Immediate	Latch	Same as Starter Module Memory Error Type 1 - Starter 2A	Local
5CC	Starter Module Memory Error Type 2 - Starter 2B	Immediate	Latch	Same as Starter Module Memory Error Type 1 - Starter 2A	Local
6B1	Starter Panel High Temperature Limit - Panel 1, Cprsr 1B	Special Mode	NonLatch	Starter Panel High Limit Thermostat (170°F) trip was detected. Note: Other diagnostics that may occur as an expected consequence of the Panel High Temp Limit trip will be suppressed from annunciation. These include Phase Loss, Power Loss, and Transition Complete Input Open for Cprsr 1B	Local
6B0	Starter Panel High Temperature Limit - Panel 1, Cprsr 2A	Special Mode	NonLatch	Same as Starter Panel High Temperature Limit - Panel 1, Cprsr 1B	Local
6B2	Starter Panel High Temperature Limit - Panel 2, Cprsr 2B	Special Mode	NonLatch	Same as Starter Panel High Temperature Limit - Panel 1, Cprsr 1B	Local
5BA	Suction Refrigerant Pressure Transducer - Circuit 1, Compressor 1A	Immediate	Latch	Bad Sensor or LLID Circuit target if no isolation valves, Compressor target if isolation valves. Design Note: In the case of manifolded compressors w/o isolation valves, the occurrence of this diagnostic will also generate a comm loss with the nonexistent Suction Press Cprsr 1B in order to accomplish circuit shutdown.	Remote
5BB	Suction Refrigerant Pressure Transducer - Circuit 1, Compressor 1B	Immediate	Latch	Same as Suction Refrigerant Pressure Transducer - Circuit 1, Compressor 1A	Remote
5BC	Suction Refrigerant Pressure Transducer - Circuit 2, Compressor 2A	Immediate	Latch	Same as Suction Refrigerant Pressure Transducer - Circuit 1, Compressor 1A	Remote
5BD	Suction Refrigerant Pressure Transducer - Circuit 2, Compressor 2B	Immediate	Latch	Same as Suction Refrigerant Pressure Transducer - Circuit 1, Compressor 1A	Remote
5B0	Transition Complete Input Opened - Compressor 1A	Immediate	Latch	The Transition Complete input was found to be opened with the compressor motor running after a successful completion of transition. This is active only for Y-Delta, Auto-Transformer, Primary Reactor, and X-Line Starters. To prevent this diagnostic from occurring as the result of a power loss to the contactors, the minimum time to trip must be greater than the trip time for the power loss diagnostic.	Local
5B1	Transition Complete Input Opened - Compressor 1B	Immediate	Latch	Same as Transition Complete Input Opened - Compressor 1A	Local
5B2	Transition Complete Input Opened - Compressor 2A	Immediate	Latch	Same as Transition Complete Input Opened - Compressor 1A	Local
5B3	Transition Complete Input Opened - Compressor 2B	Immediate	Latch	Same as Transition Complete Input Opened - Compressor 1A	Local
5AC	Transition Complete Input Shorted - Compressor 1A	Immediate	Latch	The Transition Complete input was found to be shorted before the compressor was started. This is active for all electromechanical starters.	Local
5AD	Transition Complete Input Shorted - Compressor 1B	Immediate	Latch	Same as Transition Complete Input Opened - Compressor 2B	Local
5AE	Transition Complete Input Shorted - Compressor 2A	Immediate	Latch	Same as Transition Complete Input Opened - Compressor 2B	Local
5AF	Transition Complete Input Shorted - Compressor 2B	Immediate	Latch	Same as Transition Complete Input Opened - Compressor 2B	Local



# Diagnostics

Hex Code	Diagnostic Name and Source	Severity	Persistence	Criteria	Reset Level
D8	Under Voltage	Normal	NonLatch	a. Line voltage below - 10% of nominal or the Under/Overvoltage transformer is not connected. [Must hold = - 10 % of nominal. Must trip = - 15 % of nominal. Reset differential = min. of 2% and max. of 4%. Time to trip = min. of 1 min. and max. of 5 min.] Design: Nom. trip: 60 seconds at less than 87.5%, + or - 2.8% at 200V or + or - 1.8% at 575V, Auto Reset at 90% or greater.	Remote
771	Very Low Evaporator Refrigerant Pressure - Circuit 1	Immediate	Latch	The evaporator pressure dropped below 10 psia (or 5 psia in software prior to Oct '02) regardless of whether or not compressors are running on that circuit. This diagnostic was created to prevent compressor failures due to crossbinding by forcing an entire chiller shutdown. If a given compressor or circuit is locked out, the suction pressure transducer(s) associated with it, will be excluded from causing this diagnostic.	Local
772	Very Low Evaporator Refrigerant Pressure - Circuit 2	Immediate	Latch	Same as Very Low Evaporator Refrigerant Pressure - Circuit 1	Local



# Pre-Start Checkout

---

## Installation Checklist

Complete this checklist as the unit is installed and verify that all recommended procedures are accomplished before the unit is started. This checklist does not replace the detailed instructions given in the "Installation -Mechanical" and "Installation -Electrical" sections of this manual. Read both sections completely, to become familiar with the installation procedures, prior to beginning the work.

### Receiving

- Verify that the unit nameplate data corresponds to the ordering information.
- Inspect the unit for shipping damage and any shortages of materials. Report any damage or shortage to the carrier.

### Unit Location and Mounting

- Inspect the location desired for installation and verify adequate service access clearances.
- Provide drainage for evaporator water.
- Remove and discard all shipping materials (cartons, etc.)
- Install optional rubber isolators, if required.
- Level the unit and secure it to the mounting surface.

### Unit Piping

- Flush all water piping before making final connections to the unit.

## CAUTION

### Proper Water Treatment!

**The use of untreated or improperly treated water in the Unit may result in scaling, erosion, corrosion, algae or slime. It is recommended that the services of a qualified water treatment specialist be engaged to determine what water treatment, if any, is required. Trane assumes no responsibility for equipment failures which result from untreated or improperly treated water, or saline or brackish water.**

**If using an acidic commercial flushing solution, construct a temporary bypass around the unit to prevent damage to internal components of the evaporator.**

- Connect the chilled water piping to the evaporator.
- Install pressure gauges and shutoff valves on the chilled water inlet and outlet to the evaporator.
- Install a water strainer in the entering chilled water line.
- Install a balancing valve and flow switch (recommended) in the leaving chilled water line.
- Install a drain with shutoff valve or a drain plug on the evaporator waterbox.
- Vent the chilled water system at high points in the system piping.
- Apply heat tape and insulation, as necessary, to protect all exposed piping from freeze-up.



## Pre-Start Checkout

---

### Electrical Wiring

#### **⚠ WARNING**

#### **Hazardous Voltage w/Capacitors!**

Disconnect all electric power, including remote disconnects before servicing. Follow proper lockout/tagout procedures to ensure the power cannot be inadvertently energized. For variable frequency drives or other energy storing components provided by Trane or others, refer to the appropriate manufacturer's literature for allowable waiting periods for discharge of capacitors. Verify with an appropriate voltmeter that all capacitors have discharged. Failure to disconnect power and discharge capacitors before servicing could result in death or serious injury.

**Note:** For additional information regarding the safe discharge of capacitors, see PROD-SVB06A-EN or PROD-SVB06A-FR

#### **Live Electrical Components!**

During installation, testing, servicing and troubleshooting of this product, it may be necessary to work with live electrical components. Have a qualified licensed electrician or other individual who has been properly trained in handling live electrical components perform these tasks. Failure to follow all electrical safety precautions when exposed to live electrical components could result in death or serious injury.

#### **CAUTION**

#### **Use Copper Conductors Only!**

**Unit terminals are not designed to accept other types of conductors. Failure to use copper conductors may result in equipment damage.**

- Connect the unit power supply wiring with fused-disconnect to the terminal block or lugs (or unit-mounted disconnect) in the power section of the control panel.
- Connect power supply wiring to the evaporator heaters.
- Connect power supply wiring to the chilled water pump.
- Connect power supply wiring to any auxiliary heat tapes.
- Connect the flow switch and then connect to the proper terminals.
- Connect the chilled water pump to the proper terminals.
- For the External Auto/Stop function, install wiring from remote contacts (5K14, 5K15) to the proper terminals on the circuit board.
- Connect the power supply for the convenience outlet, if it is separate from the evaporator heater.

#### **CAUTION**

#### **Information in Interconnecting Wiring!**

**Chilled Water Pump Interlock and External Auto/Stop must be adhered to or equipment damage may occur.**



## Pre-Start Checkout

---

- If alarm and status relay outputs are used, install leads from the panel to the proper terminals on circuit board.
- If the emergency stop function is used, install low voltage leads to terminals on circuit board.
- Connect separate power for the External Emergency Stop option, if applicable.
- If the ice making-option is used, install leads on 5K18 to the proper terminals on 1U7.
- Connect separate power supply for ice making status circuit, if applicable.

### General

When installation is complete, but prior to putting the unit into service, the following pre-start procedures must be reviewed and verified correct:

### **⚠ WARNING**

#### **Hazardous Voltage w/Capacitors!**

**Disconnect all electric power, including remote disconnects before servicing. Follow proper lockout/tagout procedures to ensure the power cannot be inadvertently energized. For variable frequency drives or other energy storing components provided by Trane or others, refer to the appropriate manufacturer's literature for allowable waiting periods for discharge of capacitors. Verify with an appropriate voltmeter that all capacitors have discharged. Failure to disconnect power and discharge capacitors before servicing could result in death or serious injury.**

**Note: For additional information regarding the safe discharge of capacitors, see PROD-SVB06A-EN or PROD-SVB06A-FR**

1. Inspect all wiring connections in the compressor power circuits (disconnects, terminal block, contactors, compressor junction box terminals, etc.) to be sure they are clean and tight.

### **CAUTION**

#### **Connections!**

**Verify all connections are made. Loose connections can cause overheating and undervoltage conditions at the compressor motor.**

2. Open all refrigerant valves in the discharge, liquid, suction, oil and oil return lines.

### **CAUTION**

#### **Compressor Damage!**

**Catastrophic damage to the compressor will occur if the oil line shut off valve or the isolation valves are left closed on unit start-up.**

3. Check the power supply voltage to the unit at the main power fused-disconnect switch. Voltage must be within the voltage utilization range and also stamped on the unit nameplate. Voltage imbalance must not exceed 3%.
4. Check the unit power phasing L1-L2-L3 in the starter to be sure that it has been installed in an "ABC" phase sequence.



## Pre-Start Checkout

---

### CAUTION

#### Compressor Damage!

**It is imperative that L1, L2, L3 in the starter be connected in the A-B-C phase sequence to prevent equipment damage due to reverse rotation.**

5. Fill the evaporator chilled water circuit. Vent the system while it is being filled. Open the vents on the top of the evaporator waterbox while filling and close when filling is completed.

### CAUTION

#### Proper Water Treatment!

**The use of untreated or improperly treated water in the unit may result in scaling, erosion, corrosion, algae or slime. It is recommended that the services of a qualified water treatment specialist be engaged to determine what water treatment, if any, is required. Trane assumes no responsibility for equipment failures which result from untreated or improperly treated water, or saline or brackish water.**

### CAUTION

#### Use Piping Strainers!

**To prevent evaporator damage, pipe strainers must be installed in the water supplies to protect components from water born debris. Trane is not responsible for equipment-only-damage caused by water born debris.**

6. Close the fused-disconnect switch(es) that supplies power to the chilled water pump starter.
7. Start the chilled water pump to begin circulation of the water. Inspect all piping for leakage and make any necessary repairs.
8. With water circulating through the system, adjust water flow and check water pressure drop through the evaporator.
9. Adjust the chilled water flow switch for proper operation.
10. Reapply power to complete procedures.
11. Prove all Interlock and Interconnecting Wiring Interlock and External as described in the Electrical Installation section.
12. Check and set, as required, all CH530 menu items.
13. Stop the chilled water pump.
14. Energize compressor and oil separator heaters 24 hours prior to unit start-up.

#### Unit Voltage Power Supply

Voltage to the unit must meet the criteria given in the Installation-Electrical Section. Measure each leg of the supply voltage at the unit's main power fused- disconnect. If the measured voltage on any leg is not within specified range, notify the supplier of the power and correct the situation before operating the unit.

## Pre-Start Checkout

---

### CAUTION

#### Equipment Damage!

**Provide adequate voltage to the unit. Failure to do so can cause control components to malfunction and shorten the life of relay contact, compressor motors and contactors.**

#### Unit Voltage Imbalance

Excessive voltage imbalance between the phases of three-phase system can cause motors to overheat and eventually fail. The maximum allowable imbalance is 3%. Voltage imbalance is determined using the following calculations:

$$\% \text{ Imbalance} = [(V_x - V_{\text{ave}}) \times 100] / V_{\text{ave}}$$

$$V_{\text{ave}} = (V_1 + V_2 + V_3) / 3$$

$V_x$  = phase with the greatest difference from  $V_{\text{ave}}$  (without regard to the sign)

For example, if the three measured voltages are 221, 230, and 227 volts, the average would be:

$$(221 + 230 + 227) / 3 = 226$$

The percentage of the imbalance is then:

$$[100(221 - 226)] / 226 = 2.2\%$$

This exceeds the maximum allowable (2%) by 0.2 percent.

#### Unit Voltage Phasing

### CAUTION

#### Compressor Damage!

**It is imperative that L1, L2, L3 in the starter be connected in the A-B-C phase sequence to prevent equipment damage due to reverse rotation.**

It is important that proper rotation of the compressors be established before the unit is started. Proper motor rotation requires confirmation of the electrical phase sequence of the power supply. The motor is internally connected for clockwise rotation with the incoming power supply phased A, B, C.

Basically, voltages generated in each phase of a polyphase alternator or circuit are called phase voltages. In a three-phase circuit, three sine wave voltages are generated, differing in phase by 120 electrical degrees. The order in which the three voltages of a three-phase system succeed one another is called phase sequence or phase rotation. This is determined by the direction of rotation of the alternator. When rotation is clockwise, phase sequence is usually called "ABC," when counterclockwise, "CBA."

This direction may be reversed outside the alternator by interchanging any two of the line wires. It is this possible interchange of wiring that makes a phase sequence indicator necessary if the operator is to quickly determine the phase rotation of the motor.

Proper compressor motor electrical phasing can be quickly determined and corrected before starting the unit. Use a quality instrument, such as the Associated Research Model 45 Phase Sequence Indicator, and follow this procedure.

1. Press the STOP key on the CH530.
2. Open the electrical disconnect or circuit protection switch that provides line power to the line power terminal block(s) in the starter panel (or to the unit-mounted disconnect).



## Pre-Start Checkout

### **⚠ WARNING**

#### **Hazardous Voltage w/Capacitors!**

**Disconnect all electric power, including remote disconnects before servicing. Follow proper lockout/tagout procedures to ensure the power cannot be inadvertently energized. For variable frequency drives or other energy storing components provided by Trane or others, refer to the appropriate manufacturer's literature for allowable waiting periods for discharge of capacitors. Verify with an appropriate voltmeter that all capacitors have discharged. Failure to disconnect power and discharge capacitors before servicing could result in death or serious injury.**

**Note: For additional information regarding the safe discharge of capacitors, see PROD-SVB06A-EN or PROD-SVB06A-FR**

3. Connect the phase sequence indicator leads to the line Power terminal block, as follows:

Phase Seq. Lead	Terminal
Black (Phase A)	L1
Red (Phase B)	L2
Yellow (Phase C)	L3

4. Turn power on by closing the unit supply power fused-disconnect switch.
5. Read the phase sequence on the indicator. The "ABC" LED on the face of the phase indicator will glow if phase is "ABC."
6. If the "CBA" indicator glows instead, open the unit main power disconnect and switch two line leads on the line power terminal block(s) (or the unit mounted disconnect). Re-close the main power disconnect and recheck the phasing.

### **CAUTION**

#### **Compressor Damage!**

**Do not interchange any load leads that are from the unit contactors or the motor terminals. Doing so may damage the equipment.**

7. Reopen the unit disconnect and disconnect the phase indicator.

#### **Water System Flow Rates**

Establish a balanced chilled water flow through the evaporator. The flow rates should fall between the minimum and maximum values given on the pressure drop curves. Chilled water flow rates below the minimum values will result in laminar flow, which reduces heat transfer and causes either loss of EXV control or repeated nuisance, low temperature, cutouts. Flow rates that are too high can cause tube erosion in the evaporator.

#### **Water System Pressure Drop**

Measure water pressure drop through the evaporator at the field-installed pressure taps on the system water piping. Use the same gauge for each measurement. Do not include valves, strainers fittings in the pressure drop readings.

Pressure drop readings should be approximately those shown in the Pressure Drop Charts in the Mechanical Installation section.



## **Pre-Start Checkout**

---

### **CH530 Set-Up**

Use of TechView service tool is required to view and adjust most settings. Refer to the Controls Interface section for instruction on adjustment of the settings.



# Unit Start-Up Procedures

---

## Daily Unit Start-Up

The time line for sequence of operation is shown at the end of this section and depicts the nominal delays and sequences that a chiller would experience during a typical operational cycle. The time line begins with a power up of the main power to the chiller. The sequence assumes a 2 circuit, 2 compressor air-cooled RTAC chiller with no diagnostics or malfunctioning components. External events such as the operator placing the chiller in Auto or Stop, chilled water flow through the evaporator, and application of load to the chilled water loop causing loop water temperature increases are depicted and the chillers responses to those events are shown, with appropriate delays noted. The effects of diagnostics, and other external interlocks other than evaporator water flow proving, are not considered. The response of the EasyView Display is also depicted on the time line.

*NOTE: Unless the CH530 TechView and building automation system are controlling the chilled water pump, the manual unit start sequence is as follows. Operator actions are noted.*

## CAUTION

### Compressor Damage!

**Ensure that the compressor and oil separator heaters have been operating for a minimum of 24 hours before starting. Failure to do so may result in equipment damage.**

## General

If the pre-start checkout, has been completed, the unit is ready to start.

1. Press the STOP key on the CH530.
2. As necessary, adjust the setpoint values in the CH530 menu using TechView.
3. Close the fused-disconnect switch for the chilled water pump. Energize the pump(s) to start water circulation.
4. Check the service valves on the discharge line, suction line, oil line and liquid line for each circuit. These valves must be open (backseated) before starting the compressors.

## CAUTION

### Compressor Damage!

**Catastrophic damage to the compressor will occur if the oil line shut off valve or the isolation valves are left closed on unit start-up.**

5. Press the AUTO key. If the chiller control calls for cooling and all safety interlocks are closed, the unit will start. The compressor(s) will load and unload in response to the leaving chilled water temperature.
6. Verify that the chilled water pump runs for at least one minute after the chiller is commanded to stop (for normal chilled water systems).



## Unit Start-Up Procedures

---

Once the system has been operating for approximately 30 minutes and has become stabilized, complete the remaining start-up procedures, as follows:

1. Check the evaporator refrigerant pressure and the condenser refrigerant pressure under Refrigerant Report on the CH530 TechView. The pressures are referenced to sea level (14.6960 psia).
2. Check the EXV sight glasses after sufficient time has elapsed to stabilize the chiller. The refrigerant flow past the sight glasses should be clear. Bubbles in the refrigerant indicate either low refrigerant charge or excessive pressure drop in the liquid line or a stuck open expansion valve. A restriction in the line can sometimes be identified by a noticeable temperature differential between the two sides of the restriction. Frost will often form on the line at this point. Proper refrigerant charges are shown in the General Information Section.

*NOTE: Important! A clear sight glass alone does not mean that the system is properly charged. Also check system subcooling, liquid level control and unit operating pressures.*

3. Measure the system subcooling.
4. A shortage of refrigerant is indicated if operating pressures are low and subcooling is also low. If the operating pressures, sight glass, superheat and subcooling readings indicate a refrigerant shortage, gas-charge refrigerant into each circuit, as required. With the unit running, add refrigerant vapor by connecting the charging line to the suction service valve and charging through the backseat port until operating conditions become normal.

### **CAUTION** **Refrigerant!**

**If both suction and discharge pressures are low but sub-cooling is normal, a problem other than refrigerant shortage exists. Do not add refrigerant, as this may result in overcharging the circuit.**

**Use only refrigerants specified on the unit nameplate (HFC 134a) and Trane OIL00048. Failure to do so may cause compressor damage and improper unit operation.**

### **Seasonal Unit Start-Up Procedure**

1. Close all valves and re-install the drain plugs in the evaporator.
2. Service the auxiliary equipment according to the start-up/maintenance instructions provided by the respective equipment manufacturers.
3. Close the vents in the evaporator chilled water circuits.
4. Open all the valves in the evaporator chilled water circuits.
5. Open all refrigerant valves to verify they are in the open condition.
6. If the evaporator was previously drained, vent and fill the evaporator and chilled water circuit. When all air is removed from the system (including each pass), install the vent plugs in the evaporator water boxes.
7. Check the adjustment and operation of each safety and operating control.
8. Close all disconnect switches.
9. Refer to the sequence for daily unit startup for the remainder of the seasonal startup.



## Unit Start-Up Procedures

---

### System Restart After Extended Shutdown

Follow the procedures below to restart the unit after extended shutdown:

1. Verify that the liquid line service valves, oil line, compressor discharge service valves and suction service valves are open (backseated).

### CAUTION

#### Compressor Damage!

**Catastrophic damage to the compressor will occur if the oil line shut off valve or the isolation valves are left closed on unit start-up.**

2. Check the oil separator oil level (see Maintenance Procedures section).
3. Fill the evaporator water circuit. Vent the system while it is being filled. Open the vent on the top of the evaporator and condenser while filling and close when filling is completed.

### CAUTION

#### Proper Water Treatment!

**The use of untreated or improperly treated water in the unit may result in scaling, erosion, corrosion, algae or slime. It is recommended that the services of a qualified water treatment specialist be engaged to determine what water treatment, if any, is required. Trane assumes no responsibility for equipment failures which result from untreated or improperly treated water, or saline or brackish water.**

4. Close the fused-disconnect switches that provides power to the chilled water pump.
5. Start the evaporator water pump and, while water is circulating, inspect all piping for leakage. Make any necessary repairs before starting the unit.
6. While the water is circulating, adjust the water flows and check the water pressure drops through the evaporator. Refer to "Water System Flow Rates" and "Water System Pressure Drop".
7. Adjust the flow switch on the evaporator piping for proper operation.
8. Stop the water pump. The unit is now ready for start-up as described in "Start-Up Procedures".



# Unit Shutdown Procedures

---

## Temporary Shutdown And Restart

To shut the unit down for a short time, use the following procedure:

1. Press the STOP key on the CH530. The compressors will continue to operate and, after an unloading period (which may be followed by pumpdown cycle in outdoor ambients below 50°F), will stop when the compressor contactors de-energize.
2. CH530 pump control will turn off the pump (after a minimum 1 min. delay) when the STOP key is pressed and automatically restart the pump when the unit starts normally.
3. The unit will start normally, provided the following conditions exist:
  - The CH530 receives a call for cooling and the differential-to-start is above the setpoint.
  - All system operating interlocks and safety circuits are satisfied.

## Extended Shutdown Procedure

The following procedure is to be followed if the system is to be taken out of service for an extended period of time, e.g. seasonal shutdown:

1. Test the unit for refrigerant leaks and repair as necessary.
2. Open the electrical disconnect switches for the chilled water pump. Lock the switches in the "OPEN" position.

## CAUTION Chilled Water Pump!

**Lock the chilled water pump disconnects open, to prevent pump damage.**

3. Close all chilled water supply valves. Drain the water from the evaporator.
4. With the water drained from evaporator, the "customer provided" power for the 120-volt evaporator heaters (terminated at 1TB4...terminals 1 & 2) must be must disconnect.

These heaters consist of 1 well heater in each evaporator end (or water box), and the heat tape, which is wrapped around the bundle itself. They are energized by a klixon temperature control mounted on the side of the evaporator, which energizes at or below 37°F. outside air temp. If there is no liquid in the evaporator and the temp drops below 37 degrees, both of the well heaters will burn up because they have no liquid to transfer their heat into.

5. Open the unit main electrical disconnect and unit-mounted disconnect (if installed) and lock on the "OPEN" position. If the optional control power transformer is not installed, open and lock the 115V disconnect.



## Unit Shutdown Procedure

---

### CAUTION

#### Disconnect Power!

**Lock the disconnects in the "OPEN" position to prevent accidental start-up and damage to the system when it has been setup for extended shutdown.**

6. At least every three months (quarterly), check the refrigerant pressure in the unit to verify that the refrigerant charge is intact.



## Periodic Maintenance

---

Perform all maintenance procedures and inspections at the recommended intervals. This will prolong the life of the chiller and minimize the possibility of costly failures.

Use an "Operator's Log," such as that shown at the end of the section, to record an operating history for the unit. The log serves as a valuable diagnostic tool for service personnel. By observing trends in operating conditions, an operator can anticipate and prevent problem situations before they occur. If the unit does not operate properly during maintenance inspections, refer to "Diagnostics and Troubleshooting".

After the unit has been operating for approximately 30 minutes and the system has stabilized, check the operating conditions and complete the procedures below:

### Weekly Maintenance

While unit is running in stable conditions.

1. Check MP pressure for evaporator, condenser and intermediate oil.
2. Observe liquid line sight glass on EXV.
3. If liquid line sight glass has bubbles measure the subcooling entering the EXV. The subcooling should never be less than 4 °F under any circumstances.

**A clear sightglass alone does not mean that the system is properly charged. Also check the rest of the system operating conditions.**

4. Inspect the entire system for unusual conditions and inspect the condenser coils for dirt and debris. If the coils are dirty, refer to coil cleaning.

### Monthly Maintenance

1. Perform all weekly maintenance procedures.
2. Record the system subcooling.
3. Make any repairs necessary.

### Annual Maintenance

1. Perform all weekly and monthly procedures.
2. Check oil sump oil level while unit is off.

*NOTE: Routine changing of the oil is not required. Use an oil analysis to determine the condition of the oil.*

3. Have a qualified laboratory perform a compressor oil analysis to determine system moisture content and acid level. This analysis is a valuable diagnostic tool.
4. Contact a qualified service organization to leak test the chiller, to check operating and safety controls, and to inspect electrical components for deficiencies.
5. Inspect all piping components for leakage and damage. Clean out any inline strainers.
6. Clean and repaint any areas that show signs of corrosion.
7. Clean the condenser coils.



## Periodic Maintenance

---

### **⚠ WARNING**

#### **Hazardous Voltage w/Capacitors!**

Disconnect all electric power, including remote disconnects before servicing. Follow proper lockout/tagout procedures to ensure the power cannot be inadvertently energized. For variable frequency drives or other energy storing components provided by Trane or others, refer to the appropriate manufacturer's literature for allowable waiting periods for discharge of capacitors. Verify with an appropriate voltmeter that all capacitors have discharged. Failure to disconnect power and discharge capacitors before servicing could result in death or serious injury.

**Note:** For additional information regarding the safe discharge of capacitors, see PROD-SVB06A-EN or PROD-SVB06A-FR

8. Check and tighten all electrical connections as necessary.



# Periodic Maintenance

RTAC Start-up Test Log			
Job Name		Job Location	
Model #			
CRC #		Serial #	
Sales Order #	Ship Date	Job Elevation (ft. above sea level)	
Starter Data:		Start-up Only	
Manufacturer		Chiller Appearance on arrival:	
Type: (wye-delta or x-line)		Machine gauge pressure:	ckt1/ckt2
Vendor ID #/ Model #:		Machine CH.530 pressure	ckt1/ckt2
Volts	Amps	Hz	Unit R-134a Charge lbs
Compressor Data:		Unit oil charge (OIL00048) gal	
Compressor A:		Pressure Test (if required)	
	Model #:	Vacuum after leak test= mm	
	Serial #	Standing Vacuum test= mm rise in hrs	
	RLA	Current Transformers	
	KW	Part number ("X" code and 2-digit extension)	
	Volts	X	
	HZ	X	
Compressor B:		X	
	Model #:	X	
	Serial #	X	
	RLA	X	
	KW	Summary of Options Installed	
	Volts	Y N	Tracer Communications Interface
	HZ	Y N	Ice Making
Compressor C:		Y N	Other
	Model #:	Y N	Other
	Serial #	Y N	Other
	RLA	Evap Design Conditions	
	KW	GPM	PSID
	Volts	Entering Water:	Leaving Water:
	HZ	% Glycol:	
Compressor D:		Type of Glycol:	
	Model #:		
	Serial #	Evap Actual Conditions	
	RLA	GPM	PSID
	KW	Entering Water:	Leaving Water:
	Volts	% Glycol:	
	HZ	Type of Glycol:	

Owner Witness Signature: \_\_\_\_\_



# Periodic Maintenance

RTAC Unit Configuration		
Job Name		Job Location
Model #		
Serial #		CRC#
Sales Order #	Ship Date	Job Elevation (ft. above sea level)
Setpoint View *		
Front Panel Degree Units (circle one)		F or C
Front Panel Chilled Water Setpoint		
Front Panel Current Limit		
Differential to Stop		
Differential to Start		
Leaving Water Temperature Cutout		
Low Refrigerant Temperature Cutout		
Condenser Limit		
Low Ambient Lockout Setpoint		
Low Ambient Lockout (circle one)		Enable or Disable
Under/Over Voltage Protection		Enable or Disable
Local Atmospheric Pressure		psi
Design Delta T		F or C
Reset Type (circle one)		None Return Reset Type Outdoor Air Temp. Constant Return
Return Reset Ratio		%
Return Start Reset		
Return Max Reset		
Outdoor Reset Ratio		%
Outdoor Start Reset		
Outdoor Max Reset		
Chilled Water Pump Delay Time		minutes
Chilled Water Setpoint Filtering Settling Time		sec
Compressor Staging Deadband		
Compressor Service View **		
Unit Status:		
Circuit 1 Control		
Front Panel Circuit Lockout (circle one)		Locked or Unlocked
Electronic Expansion Valve (circle one)		Open or Auto
Circuit 2 Control		
Front Panel Circuit Lockout (circle one)		Locked or Unlocked
Electronic Expansion Valve (circle one)		Open or Auto
Configuration ***		
Nameplate		
Model #		
Confirm Code		
Serial Number		

Note:

\* Using Techview, click on "View" and then click "Setpoint View" Log accordingly.

\*\* Using Techview, click on "View" and then click "Compressor Service View" Log accordingly.

\*\*\* Using Techview, click on "View" and then click "Configuration" (Nameplate Tab) Log accordingly.



# Periodic Maintenance

RTAC Chiller Log						
Job Name			Job Location			
Model #			Serial #			
<b>Status View: *</b>						
<b>Chiller Tab:</b>	15 min	30 min	45 min	15 min	30 min	45 min
Operating Mode						
Outdoor Air Temperature <i>F or C</i>						
Active Chill Water Setpoint <i>F or C</i>						
Active Current Limit Setpoint						
Evaporator Entering Water Temp. <i>F or C</i>						
Evaporator Leaving Water Temp. <i>F or C</i>						
	<b>Circuit 1 Tab</b>			<b>Circuit 2 Tab</b>		
External Hardwired Lockout	Not Locked out/ Locked out			Not Locked out/ Locked out		
Front Panel Lockout	Not Locked out/ Locked out			Not Locked out/ Locked out		
	15 min	30 min	45 min	15 min	30 min	45 min
AirFlow %						
Inverter Speed %						
Condenser Refrigerant Pressure <i>psig/kPa</i>						
Saturated Condenser Rfgt. Temp. <i>F or C</i>						
Differential Refrigerant Pressure <i>psid/kPa</i>						
Evaporator Refrigerant Pressure <i>psig/kPa</i>						
Saturated Evaporator Rfgt.Temp. <i>F or C</i>						
EXV Position %						
Evaporator Rfgt Liquid Level <i>inches/mm</i>						
	<b>Compressor 1A Tab</b>			<b>Compressor 1B Tab</b>		
Operating Mode						
Hours	Hrs/mins			Hrs/mins		
Starts						
	15 min	30 min	45 min	15 min	30 min	45 min
Phase A - B Voltage <i>volts</i>						
Average Line Current <i>%RLA</i>						
Line 1 current <i>amps</i>						
Line 2 current <i>amps</i>						
Line 3 current <i>amps</i>						
Line 1 current <i>%RLA</i>						
Line 2 current <i>%RLA</i>						
Line 3 current <i>%RLA</i>						
Evaporator Oil Return Solenoid	open / closed	open / closed	open / closed	open / closed	open / closed	open / closed
Supply Oil Temperature <i>F or C</i>						
Intermediate Oil Pressure <i>psig/kPa</i>						
Female Step solenoid	load / unload	load / unload	load / unload	load / unload	load / unload	load / unload
High Pressure Cutout switch	Good / Tripped	Good / Tripped	Good / Tripped	Good / Tripped	Good / Tripped	Good / Tripped
<b>Comments:</b>						



# Periodic Maintenance

	Compressor 2A Tab			Compressor 2B Tab		
Operating Mode						
Hours	Hrs/mins			Hrs/mins		
Starts						
	15 min	30 min	45 min	15 min	30 min	45 min
Phase A - B Voltage <i>volts</i>						
Average Line Current <i>%RLA</i>						
Line 1 current <i>amps</i>						
Line 2 current <i>amps</i>						
Line 3 current <i>amps</i>						
Line 1 current <i>%RLA</i>						
Line 2 current <i>%RLA</i>						
Line 3 current <i>%RLA</i>						
Evaporator Oil Return Solenoid	open / closed	open / closed	open / closed	open / closed	open / closed	open / closed
Supply Oil Temperature <i>F or C</i>						
Intermediate Oil Pressure <i>psig/kPa</i>						
Female Step solenoid	load / unload	load / unload	load / unload	load / unload	load / unload	load / unload
High Pressure Cutout switch	Good / Tripped	Good / Tripped	Good / Tripped	Good / Tripped	Good / Tripped	Good / Tripped
<b>Comments:</b>						

# Maintenance Procedures

---

## Refrigerant and Oil Charge Management

Proper oil and refrigerant charge is essential for proper unit operation, unit performance, and environmental protection. Only trained and licensed service personnel should service the chiller.

### Some symptoms of a refrigerant under-charged unit:

- Low subcooling
- Higher than normal discharge superheat
- Bubbles in EXV sight glass
- Low liquid level diagnostic
- Larger than normal evaporator approach temperatures (leaving water temperature - saturated evaporator temperature)
- Low evaporator refrigerant temperature limit
- Low refrigerant temperature cutout diagnostic
- Fully open expansion valve
- Possible whistling sound coming from liquid line (due to high vapor velocity)
- High condenser + subcooler pressure drop

### Some symptoms of a refrigerant over-charged unit:

- High subcooling
- Evaporator liquid level higher than centerline after shut down
- Larger than normal condenser approach temperatures (entering condenser saturated temperature – entering air temperature)
- Condenser pressure limit
- High pressure cutout diagnostic
- More than normal number of fans running
- Erratic fan control
- Higher than normal compressor power
- Very low discharge superheat at startup
- Compressor rattle or grinding sound at startup

### Some symptoms of an oil over-charged unit:

- Larger than normal evaporator approach temperatures (leaving water temperature - saturated evaporator temperature)
- Low evaporator refrigerant temperature limit
- Erratic liquid level control
- Low unit capacity
- Low discharge superheat (especially at high loads)
- Low liquid level diagnostics
- High oil sump level after normal shut down

### Some symptoms of an oil under-charged unit:

- Compressor rattle or grinding sound
- Lower than normal pressure drop through oil system
- Seized or welded compressors



# Maintenance Procedures

---

- Low oil sump level after normal shut down
- Lower than normal oil concentrations in evaporator

## **R134a Field Charging Procedure**

Be certain that the electrical power to the unit is disconnected before performing this procedure.

### **⚠ WARNING**

#### **Hazardous Voltage w/Capacitors!**

**Disconnect all electric power, including remote disconnects before servicing. Follow proper lockout/tagout procedures to ensure the power cannot be inadvertently energized. For variable frequency drives or other energy storing components provided by Trane or others, refer to the appropriate manufacturer's literature for allowable waiting periods for discharge of capacitors. Verify with an appropriate voltmeter that all capacitors have discharged. Failure to disconnect power and discharge capacitors before servicing could result in death or serious injury.**

**Note: For additional information regarding the safe discharge of capacitors, see PROD-SVB06A-EN or PROD-SVB06A-FR**

## **Factory (initial) Refrigerant Charging Procedure**

The initial charging procedure should be followed the first time the unit is charged in the factory, as well as for charging any time after the charge has been completely removed from the entire system in the event of repair.

1. As part of automatic vacuum/charge procedure, verify that the EXVs are OPEN.
2. Attach vacuum hoses to evaporator service valves (one per circuit). Open service valves.
3. Attach charging hoses to the charging port on the liquid line filter (one per circuit). The filters contain a port with a ¼" (6mm) flare.
4. Begin semi-automatic vacuum procedure.
5. When vacuum is complete (indicated), manually isolate the unit from vacuum.
6. Charge unit through the filter housing port per Table 1 - Table 5.
7. When charging is complete, shut evaporator service valve and disconnect vacuum and charging hoses.

## **Field Refrigerant Charging Procedure**

Follow this procedure when the unit is empty of all refrigerant and under a vacuum. Add the charge through the evaporator service valve.

### **CAUTION**

#### **Evaporator Damage!**

**Water must be flowing through the evaporator during the entire charging process to avoid freezing and rupturing of the evaporator tubes. Charge first with vapor to avoid freezing tubes.**

1. Note the weight of the amount of charge removed. Compare it to Table 1 - Table 5. A difference in charge may indicate a leak.

## Maintenance Procedures

---

2. Attach charging hose to evaporator service valve (3/8" (9mm) flare). Open service valve.
3. Add charge to evaporator to bring total circuit charge up to the level indicated in the above chart.
4. Close service valve and disconnect charging hose.

### **Adding charge:**

This procedure should be followed when adding charge to an undercharged unit. When low charge is indicated by low subcooling in the liquid line, charge should be added until sufficient subcooling is achieved.

1. Attach charging hose to evaporator service valve (3/8" (9mm) flare). Open service valve.
2. Add 10 pounds of refrigerant (R-134a) charge.
3. Close valve, remove charging hose and start unit. Monitor subcooling.
4. If subcooling is still insufficient, return to step #1.

*NOTE: Proper subcooling can be determined from run log history, service experience, or by contacting Trane technical service.*

### **Charge Isolation in the high or low side of system**

All the refrigerant may be trapped into the high side (condenser) of the unit for maintenance on the compressor or low side. With the suction line service valve option, charge may also be isolated in the evaporator for maintenance on the compressor or the high side. It is preferable to isolate the charge in the evaporator, if this option is available.

### **High side charge isolation procedure:**

1. Make sure circuit is off.
2. Shut liquid line service valve.
3. Shut oil return line service valve.
4. Start circuit with the service tool in charge isolation mode:
  - All fans will turn on
  - EXV will open 100%
  - Oil return line solenoid (if included) will open
  - Unit will start at minimum load
  - Unit will run until it cuts out on low pressure (~6 psia) (0.41 bar)
  - Monitor pressure with a suction gauge
5. When unit trips, the discharge check valve will close.
6. Close discharge isolation valve.
7. Close oil line shut off valve.
8. Remove the remainder of the charge with transfer pump.

*NOTE: Recommendation: Do not pump remaining charge into high side. This may introduce non condensable gasses and other contaminants into the unit.*

9. The low side and compressor may be serviced at this time.



# Maintenance Procedures

**Table 37 Charge Holding Capabilities on High Side**

Nominal Circuit Capacity	Nominal Circuit Charge lb	Condenser Charge Holding Capacity @ 60% full 90° ambient lb	Charge in Oil Separator lb	% Oil Separator Level
70	165	118.1	46.9	97.7
85	175	134.3	40.7	86.0
100	215	163.7	51.3	56.0
120	225	187.9	37.1	41.2
170	365	203.4	161.6	100.0%
200	415	282.0	133	86.1 %
240	460	325.6	134.4	86.9 %

Circuit varies slightly with efficiency and unit configuration

*NOTE: Units with a design sequence of A0 did not have enough capacity in the condenser to hold the entire charge. Table 37 lists the amount of charge that would flood the oil separator if the charge was isolated in the high side. For this reason, when getting the unit back to running condition, care must be taken to drive the refrigerant out of the oil separator using the oil separator heaters.*

**Returning unit to running condition:**

1. Open all valves.
2. Manually open EXV for 15 minutes to allow refrigerant to drain to evaporator by gravity (ensure water is flowing in the evaporator prior to opening the EXV).
3. Let unit sit with heaters on to drive refrigerant out of oil and warm up compressor bearings. Depending upon ambient conditions, this may take up to 24 hours. Ensure the UCM is powered so the pump may be energized if it detects a freeze condition.
4. Once the oil level has returned to normal, the unit can be put back into operation.

**Low side charge isolation procedure:**

After normal shut down under some conditions most of the charge resides in the evaporator. Running cold water through the evaporator may also drive much of the refrigerant to the evaporator.

1. Make sure circuit is off.
2. Close suction line isolation valve.
3. Close oil return line service valve.
4. Close liquid line service valve.
5. Manually open EXV.
6. Use a liquid pump or vacuum pump to move refrigerant from the condenser to evaporator. The liquid pump will only be effective if there is a lot of charge in the condenser. It may be connected to the condenser drain port on the liquid line isolation valve.

*NOTE: If a pump is to be used, connect it before closing this valve. This port is only isolated when the valve is back seated.*

*If a vacuum pump is used, then connect it to the discharge line service valve near the oil separator.*

*A vacuum pump will be required for part of the procedure.*



## Maintenance Procedures

---

The evaporator is large enough to hold all the charge for any unit to below the center-line of the shell. Therefore, no special precautions are required to restart the unit after isolating the charge in the evaporator.

### Refrigerant Filter Replacement Procedure

A dirty filter is indicated by a temperature gradient across the filter, corresponding to a pressure drop. If the temperature downstream of the filter is 8°F (4.4°C) lower than the upstream temperature, the filter should be replaced. A temperature drop can also indicate that the unit is undercharged. Ensure proper subcooling before taking temperature readings.

1. With the unit off, verify that the EXV is closed. Close liquid line isolation valve. On units with remote evaporators or oil cooling circuits, close ball valve on oil cooler liquid line.
2. Attach hose to service port on liquid line filter flange.
3. Evacuate refrigerant from liquid line and store.
4. Remove hose.
5. Depress schrader valve to equalize pressure in liquid line with atmospheric pressure.
6. Remove bolts that retain filter flange.
7. Remove old filter element.
8. Inspect replacement filter element and lubricate o-ring with Trane OIL00048.

*NOTE: Do not use mineral oil. It will contaminate the system.*

9. Install new filter element in filter housing.
10. Inspect flange gasket and replace if damaged.
11. Install flange and torque bolts to 14-16 lb-ft (19-22 n-m).
12. Attach vacuum hose and evacuate liquid line.
13. Remove vacuum hose from liquid line and attach charging hose.
14. Replace stored charge in liquid line.
15. Remove charging hose.
16. Open liquid line isolation valve. On units with remote evaporators or oil cooler circuits, open oil cooler liquid line ball valve.

### Lubrication System

The lubrication system has been designed to keep most of the oil lines filled with oil as long as there is a proper oil level in the oil sump.

The total oil charge can be removed by draining the oil system, oil return line from the evaporator, the evaporator, and the compressor. Very small quantities of oil may be found in other components.

Like many machines, an excessive oil charge can cause operational problems. Special care should always be taken to avoid adding extra oil.

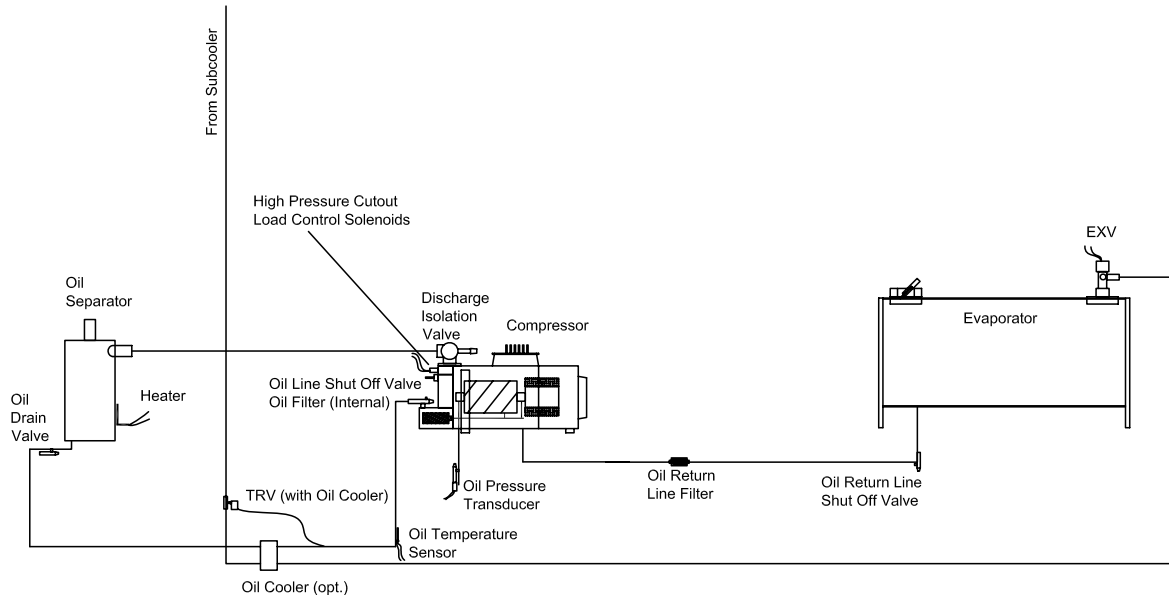
Units that exhibit the symptoms of an oil overcharge at high loads may still run fine at light loads. An oil overcharged unit may result in an evaporator limit warning or even a low liquid level or low evap temp (LRTC) diagnostic. An oil overcharged unit may exhibit increased approach temperatures and decreased overall unit efficiency.

### Oil Charging Procedure

Proper charging of the oil system is critical to the reliability of the compressor and chiller. Too little oil can cause the compressor to run hot and inefficient. When taken to an extreme, low oil level may result in instant failure of the compressor. Too much

## Maintenance Procedures

oil will result in high oil circulation rates which will foul the condenser and evaporator performance. This will result in inefficient operation of the chiller. Taken to an extreme, high oil levels may result in erratic expansion valve control or shut down of the chiller due to low evaporator refrigerant temperature. Too much oil may contribute to long term bearing wear. Additionally, excessive compressor wear is probable when the compressor is started with the oil lines dry.



**Figure 46 Oil System Schematic**

Oil system consists of the following components:

- Compressor
- Oil separator
- Discharge line with service valve
- Oil line from separator to compressor
- Oil line drain (lowest point in system)
- Oil cooler - optional
- Oil temperature sensor
- Oil line shut off valve with flare service connection
- Oil filter (internal to compressor) with flare fitting service connection and schrader valve
- Oil flow control valve (internal to the compressor after the filter)
- Oil return line from evaporator with shut off valve and strainer

Refer to Table 1 - Table 5 for the standard oil charge for each circuit.

*NOTE: Recommendation: check the oil level in the sump using a sight glass or a manometer, attached to charging hoses.*

# Maintenance Procedures

**Table 38 Oil Charging Data**

Circuit (Tons)	Approximate sump oil level after running "normal" conditions (in)	Normal quantity of oil in refrigeration system (evaporator/condenser) lb (gal)
70	7	1.1 (0.14)
85	6	1.1 (0.14)
100	7	1.8 (0.23)
120	7	1.8 (0.23)
170	8	3.5 (0.44)
200	8	3.5 (0.44)
240	8	3.5 (0.44)

1. To **measure oil level**, use the oil drain valve on the oil line and a service valve on the discharge line. This measurement can only be made when the circuit is not running.

**Note:** The level is measured from the bottom of the separator and 1" must be subtracted for the thickness of the bottom plate.

2. The initial oil charge should be approximately at the level in the above chart. This is the approximate oil level if all the oil is in the oil lines, filter and oil sump and the unit is in vacuum so that there is no refrigerant dissolved in the oil.
3. After the unit has run for a while, the oil level in the sump can vary greatly. However, if the unit has run "normal" conditions for a long time the level should resemble the level in the above chart. (+1" to -4" (25 to -101mm) is acceptable.)

The field charging procedure depends on the circumstances that resulted in the need for oil charge.

1. Some service procedures may result in loss of small quantities of oil which must be replaced (oil analysis, filter replacement, re-tubing the evaporator, etc.).
2. Additionally, some maintenance procedures may result in virtually all of the oil being removed (compressor motor burn or total removal of the charge to trouble shoot a unit).
3. Finally, leaks may result in a loss of oil that must be replaced.

### Factory (initial) Oil Charging Procedure

The initial charging procedure should be followed any time the unit is new or has had all of the oil removed.

4. If the isolation valves is closed, then the charge may be trapped in the evaporator. In either case, the high side of the system should not be pressurized.
5. The oil line shut off valve must be open to allow the oil to pass into the oil lines and the oil separator.
6. The oil charging port is a ¼" (6mm) flare fitting with a schrader valve that is on the side of the oil filter housing. This is the port that must be used to add oil into the compressor so that the filter and lines are full at the first start of the compressor.
7. On single compressor circuits all the oil should be put into the circuit through the oil charging port on the compressor filter housing. On two compressor circuits put approximately ½ of the oil into the unit through each of the two oil charging ports on the two compressors.
8. Oil may be put into the unit using either of two methods:



# Maintenance Procedures

---

## CAUTION Equipment Damage!

**Use only Trane OIL00048 in the RTAC units to avoid any catastrophic damage to the compressor or unit.**

- Have the unit in vacuum. Note that the vacuum connection should be made on the unit at the service valve that is on the discharge line. Hook up the oil charging hose to the oil charging fitting and submerge the other end into the oil container. Let the vacuum draw the required amount of oil into the unit.
- Have the unit at the same pressure as the oil. Hook up the oil charging hose to the oil charging fitting and the other end to an oil pump. Use the pump to draw oil out of the oil container and push the required amount of oil into the unit.

*NOTE: The compressor filter has an internal shut off valve that will prevent oil from entering the compressor while the compressor is not running. Therefore, there is no concern about flooding the compressor with oil.*

### Field Oil Charging Procedure

Use the initial charging procedure under the following circumstances:

- When virtually all of the oil has been removed.
- If the oil charge is removed from the compressor and oil system only but the unit has been run for less than 15 minutes.
- If the oil charge is removed from the compressor and oil system only and the unit has been run for more than 15 minutes. However, reduce the amount of oil added to the unit by the normal quantity of oil in refrigeration system.

*NOTE: This procedure can be followed even with the refrigerant charge isolated in the evaporating section of the unit.*

**If small quantities of oil were removed to service refrigeration components**, such as the evaporator, simply replace the oil that was removed into the serviced component prior to vacuum and recharge of the refrigerant.

**If oil was removed from the compressor only to service a compressor or change the oil filter** follow this procedure:

1. If the compressor is a new compressor or has been removed from the system and reworked, add 1 quart (2 lb.) oil to the motor cavity prior to installing the compressor into the chiller.
2. Install the compressor in the system. Make sure that the filter shut off valve is closed. Other compressor isolation valves may also be closed depending upon the service that was completed. For example, changing the oil filter would require the compressor to be isolated and pulled into vacuum.

*NOTE: Make sure that compressor is not pressurized.*

3. Open the flare fitting on the oil line shut off valve.
4. Open the flare fitting on the filter housing. This is the port that must be used to put oil into the compressor.
5. Install charging hose on oil charging port (with schrader valve) and the other on the oil canister.
6. Lift the oil canister, or use a pump, to pour oil into the filter housing.

## Maintenance Procedures

---

7. When oil comes out of the flare fitting on the oil line shut off valve the filter is full. Stop adding oil.
8. Put the cap on the flare on the oil line shut off valve, remove the charging hose and put the cap back on the flare on the filter housing.
9. Vacuum the compressor (low side) and prepare it for inclusion in the system. There is a service valve on the suction line and on the evaporator. Use these valves to vacuum the compressor.
10. Open the oil line shut off valve. Severe damage to the compressor can result if the oil line shut off valve is closed when the compressor is started.

### CAUTION

#### Compressor Damage!

**Catastrophic damage to the compressor will occur if the oil line shut off valve or the isolation valves are left closed on unit start-up.**

11. Open the other compressor isolation valves.

*NOTE: This procedure assumes that the oil that is put into the filter housing does not have contaminants such as non-condensable gases. The oil forces these gases out of the filter and oil line shut off valve without the need to pull a vacuum on this small volume. If the oil has been in an open container or is otherwise contaminated, then this small volume must be subject to vacuum as well. However, the filter cavity is full of oil. Therefore, be sure to use a flash tank in line with the vacuum pump to make sure that oil, that is pulled out of the filter cavity, does not slug the vacuum pump.*

#### Evaporator tube replacement

The units were designed for installation of the tubes from the end of the evaporator opposite the control panel end.

The following units will need to have the circuit 2 control panel removed to replace tubes in the evaporator.

- 30' Base - 3 compressor units
- 36' Base - 3 compressor units

### CAUTION

#### Evaporator Damage!

**The tubes are rolled at both ends and in the center. When replacing tubes, take care to ensure that the tube is removed and rolled into the center tube sheet properly. Failure to do so could result in damage to the tubes and improper operation of the system.**

#### Compressor Replacement

If a compressor needs to be replaced follow the procedures listed below.

1. Isolate the refrigerant charge outside of the compressor and close all four valves leading to the compressor. This includes the oil line service valve located on the oil filter cover of the compressor, the valve on the oil return line from the evaporator, the discharge service valve, and the suction service valve. In the event that the optional suction service valve was not ordered with the unit, insure that the liquid line service valve is closed.



## Maintenance Procedures

---

2. Disconnect power to the chiller. Remove the electrical junction box cover and disconnect the wires.

**⚠ WARNING**  
**Hazardous Voltage!**

**Disconnect all electric power, including remote disconnects before servicing. Follow proper lockout/tagout procedures to ensure the power can not be inadvertently energized. Failure to disconnect power before servicing could result in death or serious injury.**

3. Evacuate the compressor through the service fitting provided. If the unit does not have suction service valves, this will include evacuating the low side of the system as well. Disconnect all four lines attached to the compressor, as well as the junction box. Remove three screws from the bottom of the compressor.
4. Remove the compressor by sliding it out of the chiller onto a well supported skid or other platform. The compressor is very heavy, so insure that the support is sturdy. A piece of 1x4 lumber placed between the isolators works well to support the compressor feet as it is pulled from the chiller.
5. Install the new compressor. Reinstall all lines, wires, and screws. Open the service valves, and trim charge as required.

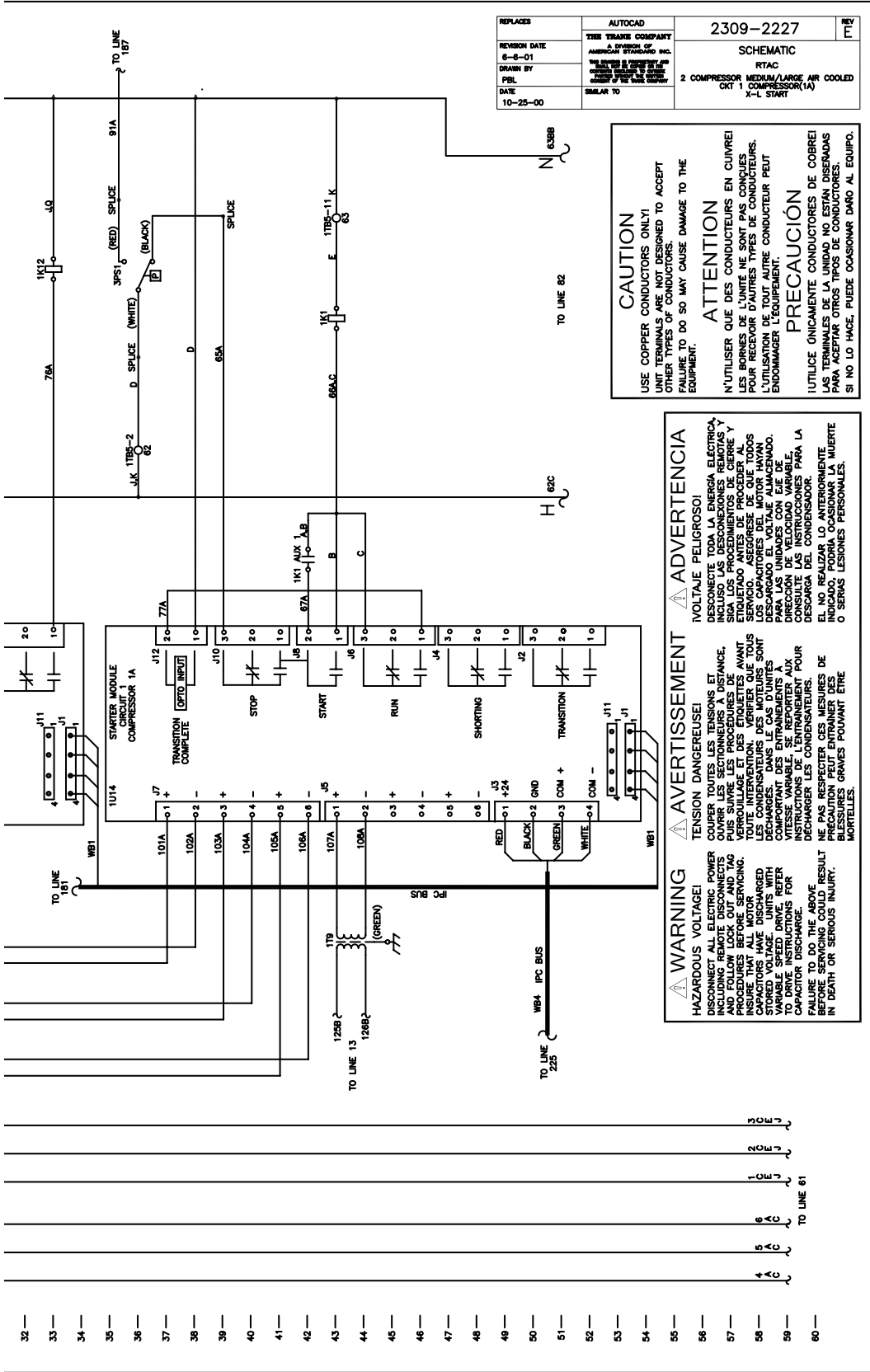


## Unit Wiring

This section provides field wiring diagrams, electrical schematics and connection diagrams for 140-500 ton RTAC units.

<b>Drawing Number</b>	<b>Description</b>	<b>Page</b>
2309-2227	Schematic, M&L, X-L, Ckt 1	166
2309-2228	Schematic, M&L, X-L, Ckt 2	168
2309-2229	Schematic, M&L, Y-D, Ckt 1	170
2309-2230	Schematic, M&L, Y-D, Ckt 2	172
2309-1988	Schematic, 3&4 Comp, Comp 1A, X-L	174
2309-1989	Schematic, 3&4 Comp, Comp 1B, X-L	176
2309-1990	Schematic, 3&4 Comp, Comp 1A, Y-D	178
2309-1991	Schematic, 3&4 Comp, Comp 1B, Y-D	180
2309-1996	Schematic, 3 Comp, Comp 2A, X-L	182
2309-1997	Schematic, 3 Comp, Comp 2A, Y-D	184
2309-1999	Schematic, Fans, 3 Comp, Ckt2	186
2309-2201	Schematic, 4 Comp, Comp 2A, X-L	188
2309-2202	Schematic, 4 Comp, Comp 2B, X-L	190
2309-2203	Schematic, 4 Comp, Comp 2A, Y-D	192
2309-2204	Schematic, 4 Comp, Comp 2B, Y-D	194
2309-2241	Schematic, Fans, Medium, 140&155 Std	196
2309-2242	Schematic, Fans, Medium, all others	198
2309-2231	Schematic, Fans, Large (225&250 Prem)	200
2309-4876	Schematic, Fans, 3&4 Comp, Ckt1, Low Volt	202
2309-1992	Schematic, Fans, 3&4 Comp, Ckt1, High Volt	204
2309-2217	Schematic, Fans, 3 Comp, Ckt1, 250T, 50Hz, Std	206
2309-4877	Schematic, Fans, 4 Comp, Ckt2, Low Volts	208
2309-2205	Schematic, Fans, 4 Comp, Ckt2, High Volt	210
2309-1352	Schematic, Control, M&L	212
2309-4880	Schematic, Controls, 3&4 Comp, Ckt1	214
2309-4882	Schematic, Controls/Legend/Bus, 3 Comp, Ckt2	216
2309-4883	Schematic, Controls, 4 Compressor, Ckt2	218
2309-1353	Schematic, Legend/LLID Bus, M&L	220
2309-4881	Schematic, Legend/LLID Bus, 3&4 Comp, Ckt1	222
2309-4884	Schematic, Legend/LLID Bus, 4 Comp, Ckt2	224
2309-2243	Schematic, Fans, M&L, Inverters	226
2309-4899	Schematic; Remote Evap	228
2309-4871	Component Location, 2 Comp	230
2309-4874	Component Location, 3 Comp	232
2309-4873	Component Location, 4 Comp	234
2309-2219	Schematic, 3&4 Comp, Single Source Panel	236
2309-2222	Field Wiring, 3&4 Comp, Dual Source Pwr	238
2309-2248	Field Layout, All	240
2309-2239	Field Layout, 3&4 Comp	242
2309-2208	Field Wiring, All	244
2309-2246	Customer Lug Size	245
2309-2223	Field Wiring, 3&4 Comp, Single Source Pwr	246
2309-4872	Component Location, Remte Evap	248
2309-1974	Field Wiring, Remote Evap	250





REPLACES	AUTOCAD
REVISION DATE	6-8-01
DRAWN BY	FBI
DATE	10-25-00

THE TRANE COMPANY A DIVISION OF AMERICAN STANDARD INC. 1000 W. WASHINGTON ST. MILWAUKEE, WI 53224 TEL: 414.224.2000	
SIMILAR TO	

2309-2227	REV E
SCHEMATIC	
RTAC	
2 COMPRESSOR SYSTEM LARGE AIR COOLED CKT 1 COMPRESSOR(A)	
X-1 START	

**CAUTION**  
USE COPPER CONDUCTORS ONLY!  
UNIT TERMINALS ARE NOT DESIGNED TO ACCEPT OTHER TYPES OF CONDUCTORS.  
OTHERWISE, IT MAY CAUSE DAMAGE TO THE EQUIPMENT.

**ATTENTION**  
N'UTILISER QUE DES CONDUCTEURS EN CUIVRE!  
LES BORNES DE L'UNITÉ NE SONT PAS CONÇUES POUR RECEVOIR D'AUTRES TYPES DE CONDUCTEURS.  
L'UTILISATION DE TOUT AUTRE CONDUCTEUR PEUT ENDOMMAGER L'ÉQUIPEMENT.

**PRECAUCIÓN**  
UTILICE ÚNICAMENTE CONDUCTORES DE COBRE!  
LAS TERMINALES DE LA UNIDAD NO ESTÁN DISEÑADAS PARA ACEPTAR OTROS TIPOS DE CONDUCTORES.  
SI NO LO HACE, PUEDE OCASIONAR DAÑO AL EQUIPO.

**WARNING**  
HAZARDOUS VOLTAGE!  
DISCONNECT ALL ELECTRIC POWER BEFORE SERVICING.  
FOLLOW LOCK OUT AND TAG OUT PROCEDURES.  
CAPACITORS HAVE STORED ENERGY AND WILL DISCHARGE.  
REFER TO THE SERVICE MANUAL FOR CAPACITOR DISCHARGE PROCEDURES.  
FAILURE TO DO THE ABOVE BEFORE SERVICING COULD RESULT IN DEATH OR SERIOUS INJURY.

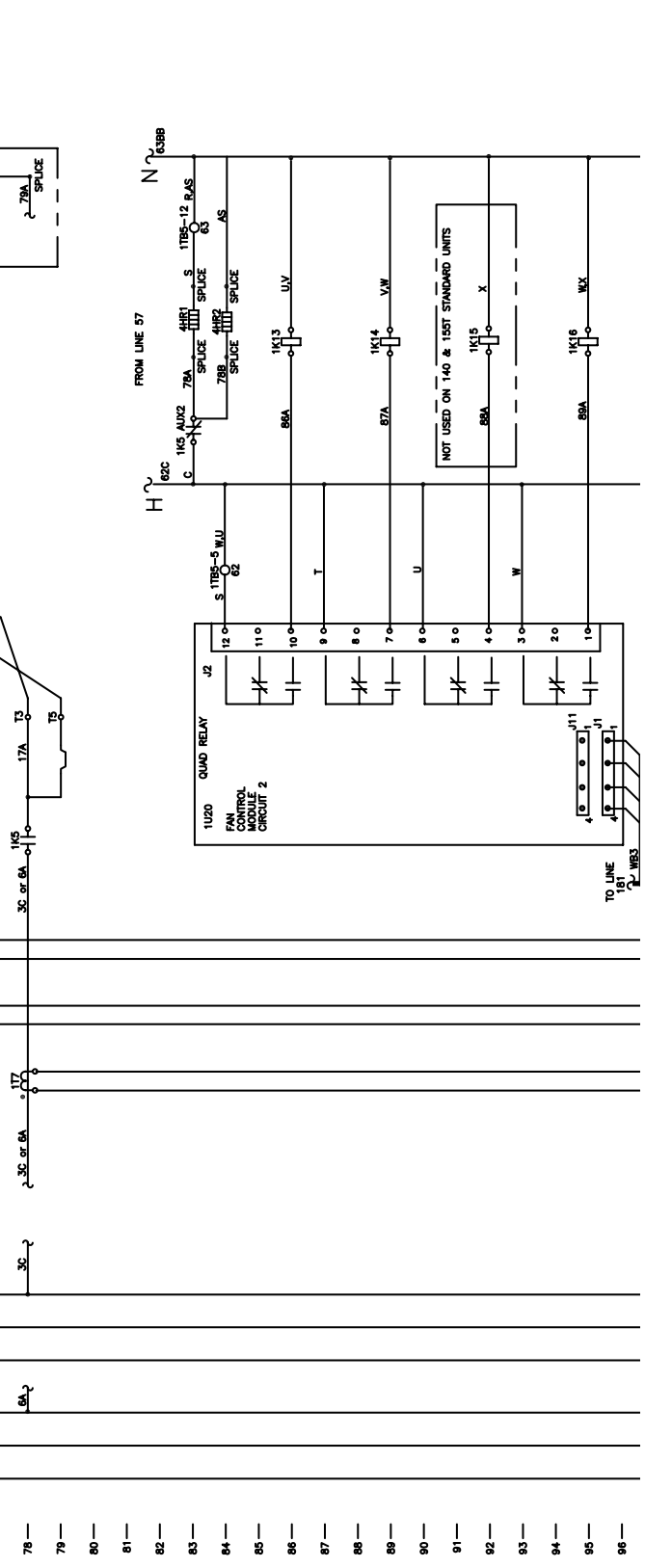
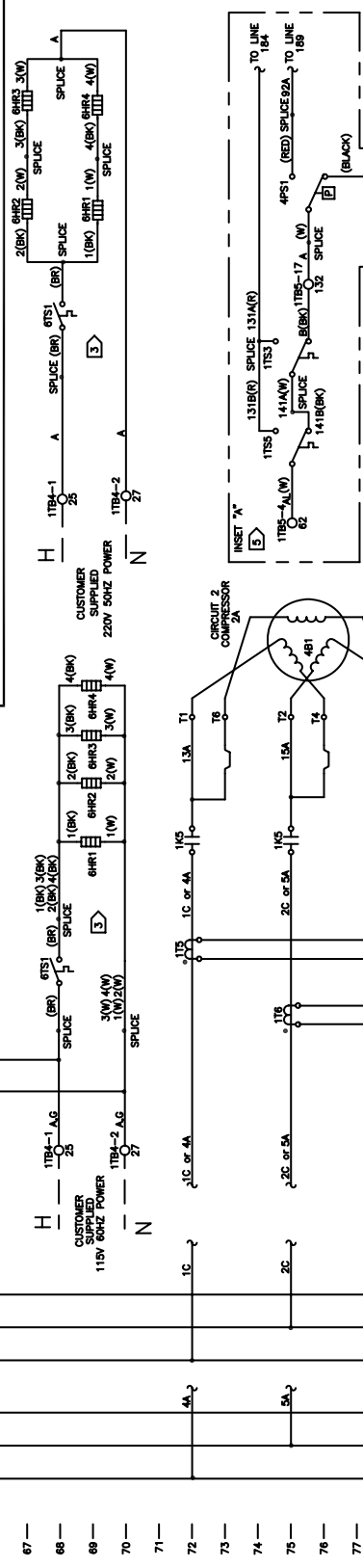
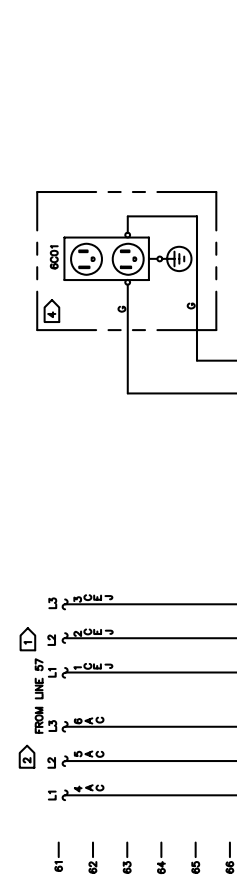
**AVERTISSEMENT**  
TENSION DANGEREUSE!  
COUPER TOUTES LES TENSIONS AVANT LE TRAVAIL.  
SUIVRE LES PROCÉDURES DE VERROUILLAGE ET DES ÉTIQUETTES AVANT LE TRAVAIL.  
LES CONDENSATEURS DES UNITÉS ONT DE L'ÉNERGIE STOCKÉE ET SE DÉCHARGENT.  
CONSULTEZ LE MANUEL DE SERVICE POUR LES PROCÉDURES DE DÉCHARGEMENT DES CONDENSATEURS.  
NE PAS RESPECTER CES MESURES DE PRÉCAUTION PEUT ENTRAINER DES BLESSURES GRAVES POUVANT ÊTRE MORTELLES.

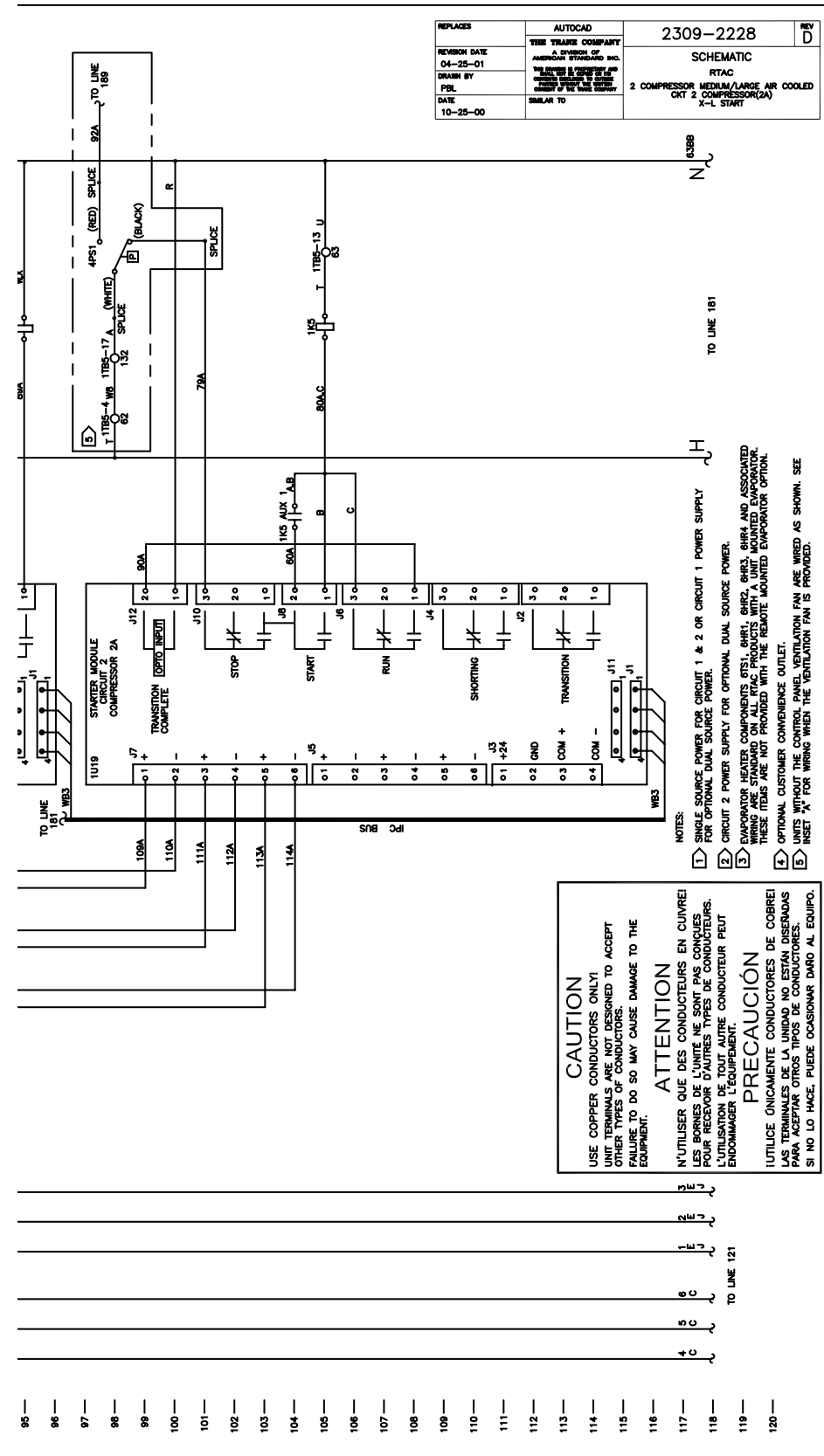
**ADVERTENCIA**  
¡VOLTAJE PELIGROSO!  
DESCONECTE TODA LA ENERGÍA ELÉCTRICA ANTES DE TRABAJAR.  
SIGA LOS PROCEDIMIENTOS DE CERRADO Y ETIQUETADO ANTES DE PROCEDER AL TRABAJO.  
LOS CAPACITORES DEL MOTOR HAN SIDO DESCARGADOS EL VOLTAJE ALMACENADO PARA LAS UNIDADES CON EJE DE CIERRE.  
CONSULTE LAS INSTRUCCIONES PARA LA DESCARGA DEL CONDENSADOR.  
EL NO REALIZAR LO ANTERIORMENTE INDICADO, PODRÍA OCASIONAR LA MUERTE O SERIAS LESIONES PERSONALES.

**HAZARDOUS VOLTAGE!**  
DISCONNECT ALL ELECTRIC POWER INCLUDING REMOTE DISCONNECTS AND FOLLOW LOCK OUT AND TAG PROCEDURES BEFORE SERVICING. INSURE THAT ALL MOTOCHARGED CAPACITORS HAVE DISCHARGED TO DRIVE INSTRUCTIONS FOR CAPACITOR DISCHARGE. FAILURE TO DO THE ABOVE BEFORE SERVICING COULD RESULT IN DEATH OR SERIOUS INJURY.

**AVERTISSEMENT TENSION DANGEREUSE!**  
COUPER TOUTES LES TENSIONS ET PUIS SUIVRE LES PROCEDURES DE VERIFICATION AVANT LE SERVICE. ASSUREZ-VOUS QUE TOUS LES CONDENSATEURS DES MOTEURS SONT DECHARGES. DANS LE CAS D'UNITES MOTOCHARGES, SUIVRE LES INSTRUCTIONS POUR LA DECHARGE DES CONDENSATEURS. NE PAS RESPECTER CES MESURES DE PREVENTION PEUT ENTRAÎNER LA MORT OU DES BLESSURES GRAVES POUVANT ETRE MORTELLES.

**ADVERTENCIA VOLTAJE PELIGROSO!**  
DESCONECTE TODA LA ENERGIA ELECTRICA INCLUIDO LAS DESCONEXIONES REMOTAS SIGA LOS PROCEDIMIENTOS DE CIERRE Y VERIFICACION ANTES DE SERVICIAR. ASSEGURESE DE QUE TODOS LOS CAPACITORES DEL MOTOR HAYAN DESCARGADO EL VOLTAJE ALMACENADO. EN EL CASO DE UNIDADES MOTOCHARGADAS, SIGA LAS INSTRUCCIONES PARA LA DESCARGA DEL CONDENSADOR. EL NO REALIZAR LO ANTERIORMENTE PODRIA ENTRAÑAR LA MUERTE O SERIAS LESIONES PERSONALES.





REPLACES	AUTOCAD	2309-2228	REV
REVISION DATE	THE YERGEN COMPANY		D
04-25-01	A DIVISION OF		
DRAWN BY	ALBERTSON STRONG, INC.	SCHEMATIC	
PBL	THE YERGEN COMPANY	RTAC	
DATE	10-25-00	2 COMPRESSOR MEDIUM-LARGE AIR COOLED	
	SIMILAR TO	CKT 2 COMPRESSOR(A)	
		X-L START	

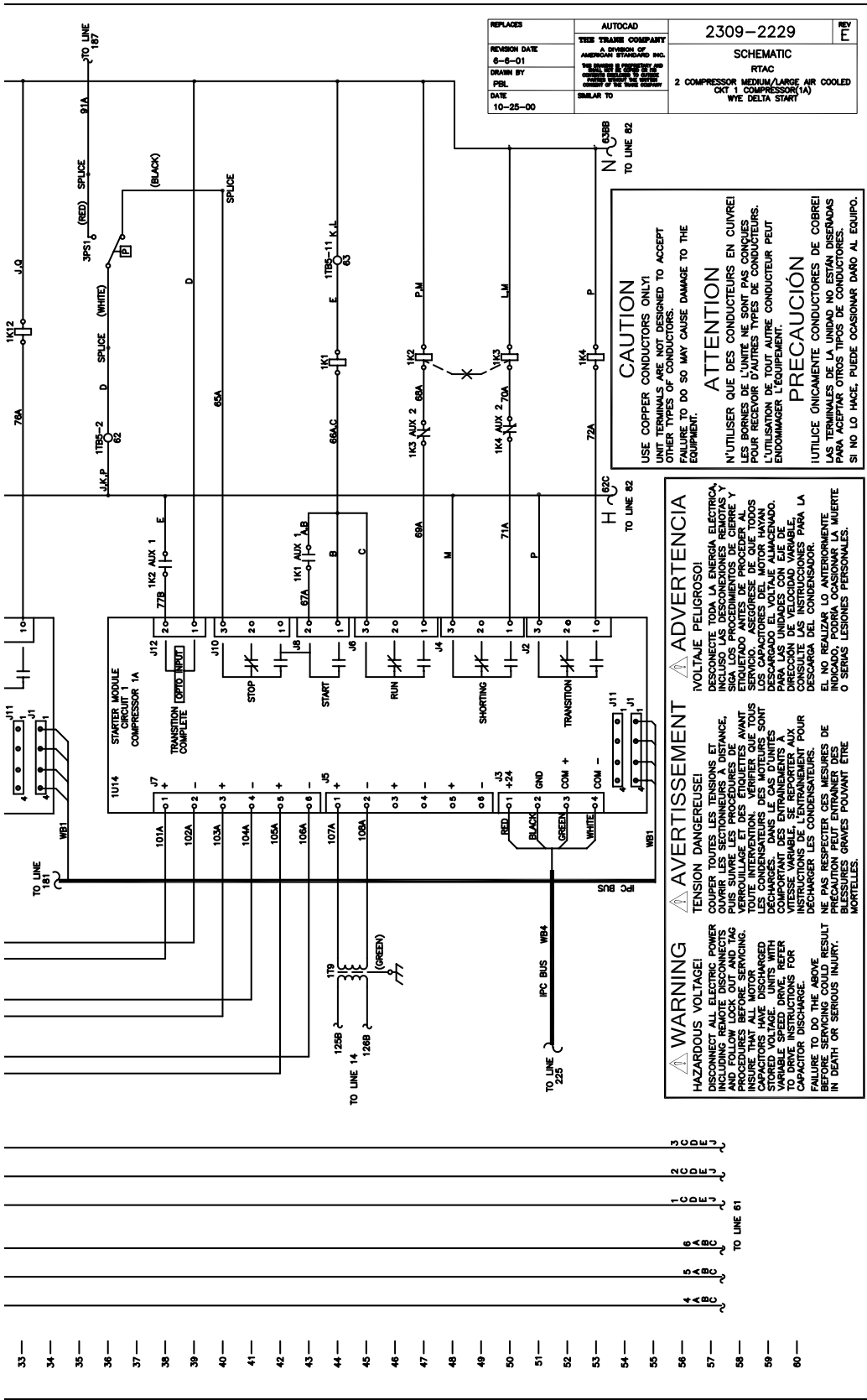
- NOTES:
- 1) SINGLE SOURCE POWER FOR CIRCUIT 1 & 2 OR CIRCUIT 1 POWER SUPPLY FOR OPTIONAL DUAL SOURCE POWER.
  - 2) CIRCUIT 2 POWER SUPPLY FOR OPTIONAL DUAL SOURCE POWER.
  - 3) EVAPORATOR HEATER COMPONENTS 6TS1, 6HR1, 6HR2, 6HR3, 6HR4 AND ASSOCIATED WIRING ARE STANDARD ON ALL RTAC PRODUCTS WITH A UNIT MOUNTED EVAPORATOR. THESE ITEMS ARE NOT PROVIDED WITH THE REMOTE MOUNTED EVAPORATOR OPTION.
  - 4) OPTIONAL CUSTOMER COMMENCE OUTLET.
  - 5) UNITS WITHOUT THE CONTROL PANEL VENTILATION FAN ARE WIRED AS SHOWN. SEE INSET 'X' FOR WIRING WHEN THE VENTILATION FAN IS PROVIDED.

**CAUTION**  
 USE COPPER CONDUCTORS ONLY!  
 UNIT TERMINALS ARE NOT DESIGNED TO ACCEPT OTHER TYPES OF CONDUCTORS.  
 FAILURE TO DO SO MAY CAUSE DAMAGE TO THE EQUIPMENT.

**ATTENTION**  
 N'UTILISER QUE DES CONDUCTEURS EN CUIVRE!  
 LES BORNES DE L'UNITÉ NE SONT PAS CONÇUES POUR ACCEPTER D'AUTRES TIPOUS DE CONDUCTEURS.  
 L'UTILISATION DE TOUT AUTRE CONDUCTEUR PEUT ENDOMMAGER L'ÉQUIPEMENT.

**PRECAUCIÓN**  
 ¡UTILICE ÚNICAMENTE CONDUCTORES DE COBRE!  
 LAS TERMINALES DE LA UNIDAD NO ESTÁN DISEÑADAS PARA ACEPTAR OTROS TIPOS DE CONDUCTORES.  
 SI NO LO HACE, PUEDE OCASIONAR DAÑO AL EQUIPO.

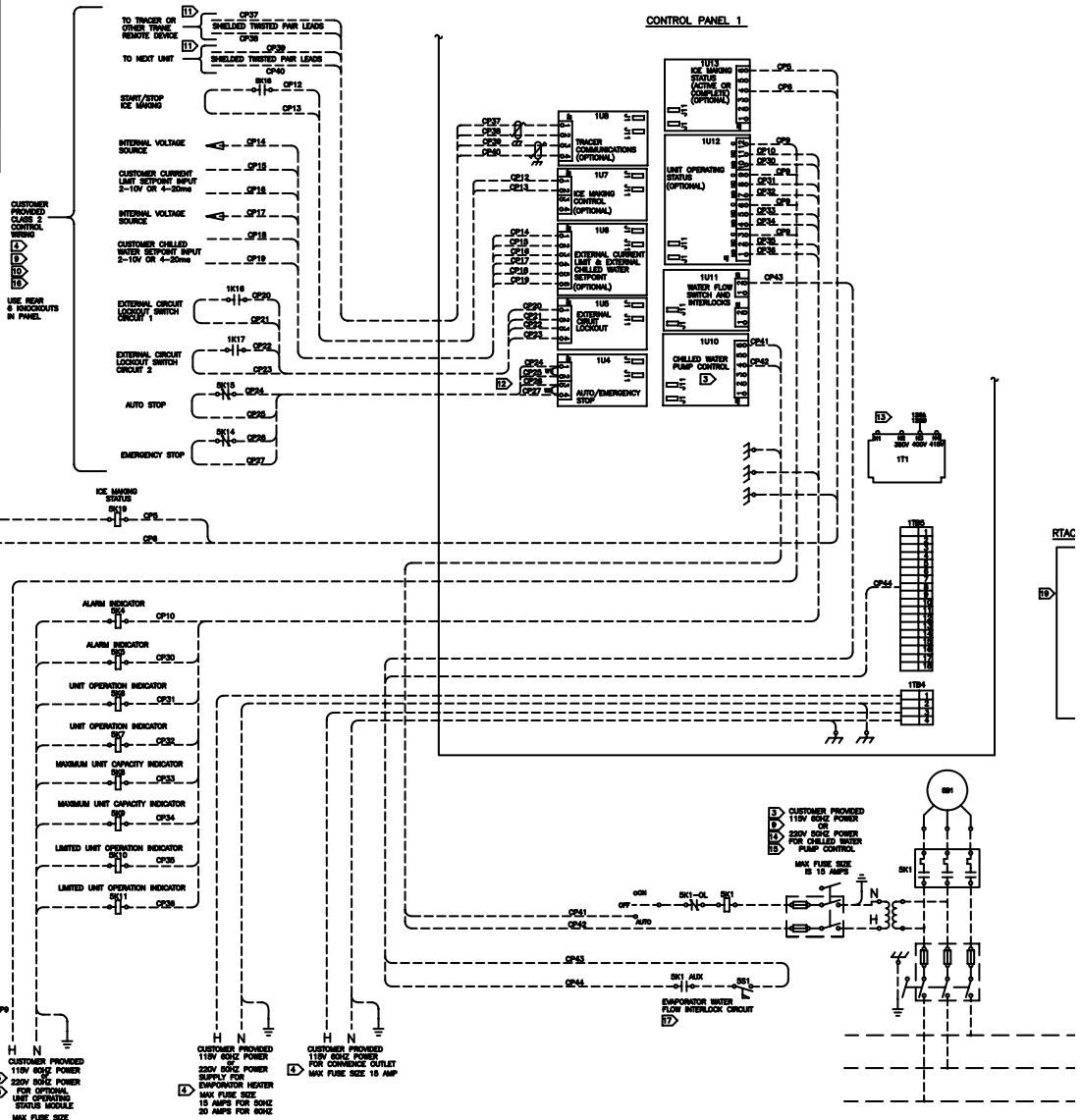




**CAUTION**  
USE COPPER CONDUCTORS ONLY!  
UNIT TERMINALS ARE NOT DESIGNED TO ACCEPT OTHER TYPES OF CONDUCTORS.  
FAILURE TO DO SO MAY CAUSE DAMAGE TO THE EQUIPMENT.

**ATTENTION**  
UTILISER QUE DES CONDUCTEURS EN CUIVRE!  
LES BORNES DE L'UNITÉ NE SONT PAS CONÇUES POUR RECEVOIR D'AUTRES TYPES DE CONDUCTEURS.  
L'UTILISATION DE TOUT AUTRE CONDUCTEUR PEUT ENDOMMAGER L'ÉQUIPEMENT.

**PRECAUCIÓN**  
UTILICE ÚNICAMENTE CONDUCTORES DE COBRE!  
LAS TERMINALES DE LA LÍNEA NO ESTÁN DISEÑADAS PARA ACEPTAR OTROS TIPOS DE CONDUCTORES.  
SI NO LO HACE, PUEDE OCASIONAR DAÑO AL EQUIPO.



**WARNING**  
HAZARDOUS VOLTAGE!  
DISCONNECT ALL ELECTRIC POWER INCLUDING REMOTE DISCONNECTS AND FOLLOW LOCK OUT AND TAG PROCEDURES BEFORE SERVICING. INSURE THAT ALL MOTOR CAPACITORS HAVE DISCHARGED STORED VOLTAGE. UNITS WITH VARIABLE SPEED DRIVE, REFER TO OWNER INSTRUCTIONS FOR CAPACITOR DISCHARGE. FAILURE TO DO THE ABOVE BEFORE SERVICING COULD RESULT IN DEATH OR SERIOUS INJURY.

**AVERTISSEMENT**  
TENSION DANGEREUSE!  
COUPER TOUTES LES TENSIONS ET SUIVRE LES PROCÉDURES DE DÉBRANCHEMENT ET DES ÉTIQUETTES AVANT TOUTE INTERVENTION. ASSURER QUE TOUS LES CONDENSATEURS DES MOTEURS SONT DÉCHARGÉS. DANS LE CAS D'UNITÉS COMPORTANT DES ENTRAÎNEMENTS À VITESSE VARIABLE, SE RÉFÉRER AUX INSTRUCTIONS DE L'ENTRAÎNEMENT POUR DÉCHARGER LES CONDENSATEURS. NE PAS RESPECTER CES MESURES DE PRÉCAUTION PEUT ENTRAINER DES BLESSURES GRAVES POUVANT ÊTRE MORTELLES.

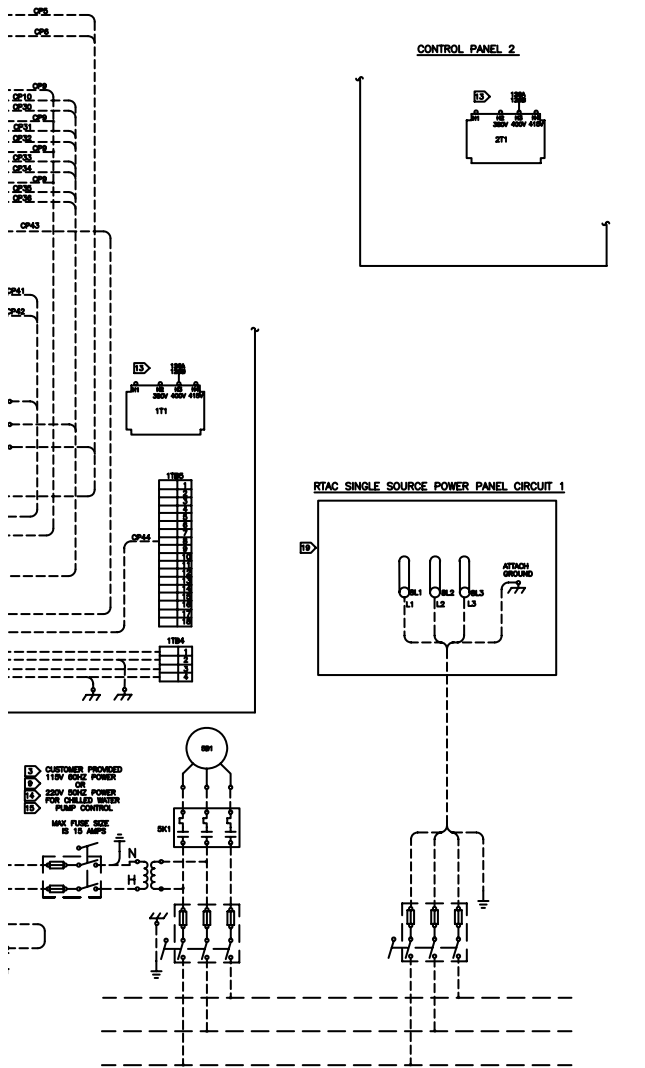
**ADVERTENCIA**  
VOLTAJE PELIGROSO!  
DESCONECTE TODA LA ENERGÍA ELÉCTRICA, INCLUIDO LAS DESCONECCIONES REMOTAS, Y SIGA LOS PROCEDIMIENTOS DE CERRAJE Y ETIQUETADO ANTES DE PROCEDER AL SERVICIO. ASEGURESE DE QUE TODOS LOS CAPACITORES DEL MOTOR HAYAN DESCARGADO EL VOLTAJE ALMACENADO. PARA LAS UNIDADES CON EJE DE FRECUENCIA DE VELOCIDAD VARIABLE, CONSULTE LAS INSTRUCCIONES PARA LA DESCARGA DEL CONDENSADOR. EL NO REALIZAR LO ANTERIORMENTE MENCIONADO, PUEDE OCASIONAR LA MUERTE O SERIAS LESIONES PERSONALES.

- GENERAL NOTES:**
- CAUTION-DO NOT ENERGIZE THE UNIT UNTIL CHECK OUT AND STARTUP PROCEDURES HAVE BEEN COMPLETED.
  - ALL MOTORS ARE PROTECTED FROM PRIMARY SINGLE PHASE FAILURES.
  - CAUTION-TIME CONTROL MUST BE USED TO PROVIDE PUMP CONTROL. EVAPORATOR CHILLED WATER PUMP MUST BE CONTROLLED BY THE GRILLER OUTPUT. FAILURE TO COMPLY WITH THIS REQUIREMENT MAY RESULT IN DAMAGE TO THE UNIT.
  - THE FOLLOWING FEATURES ARE OPTIONAL AND MAY OR MAY NOT BE PROVIDED. CUSTOMER PROVIDED WIRING FOR ALL STANDARD FEATURES AND OPTIONS IS SHOWN ON THIS DIAGRAM. OPTIONAL FEATURES ARE SO NOTED.
- LOW VOLTAGE OPTIONS (CLASS 2)**
- TRACER COMMUNICATION INTERFACE**
- ICE MAKING START/STOP**
- EXTERNAL CURRENT LIMIT AND EXTERNAL CHILLED WATER SETPOINT**
- 115 VOLT OPTIONS FOR 80HZ, OR 230 VOLT OPTIONS FOR 60HZ.**
- ICE MAKING STATUS**
- UNIT OPERATING STATUS MODULE**
- EVAPORATOR HEATER (FREEZE PROTECTION), STANDARD WITH UNIT MOUNTED EVAPORATOR. NOT USED WITH REMOTE EVAPORATOR OPTION.**
- CONVEGENCE OUTLET IS AVAILABLE ONLY ON 80HZ UNITS.**
- LINE VOLTAGE OPTIONS**
- SINGLE OR DUAL SOURCE POWER MAY BE SPECIFIED. THIS DRAWING COVERS THE SINGLE SOURCE POWER OPTION. WHEN SINGLE SOURCE POWER IS SPECIFIED AN ADDITIONAL PANEL IS PROVIDED FOR FIELD POWER WIRING. THIS PANEL IS AVAILABLE ONLY WITH TERMINAL BLOCKS OR LUGS. IN THIS CASE CONTROL PANELS 1 AND 2 ARE ALWAYS PROVIDED WITH A SINGLE TRIP TYPE CIRCUIT BREAKER.**

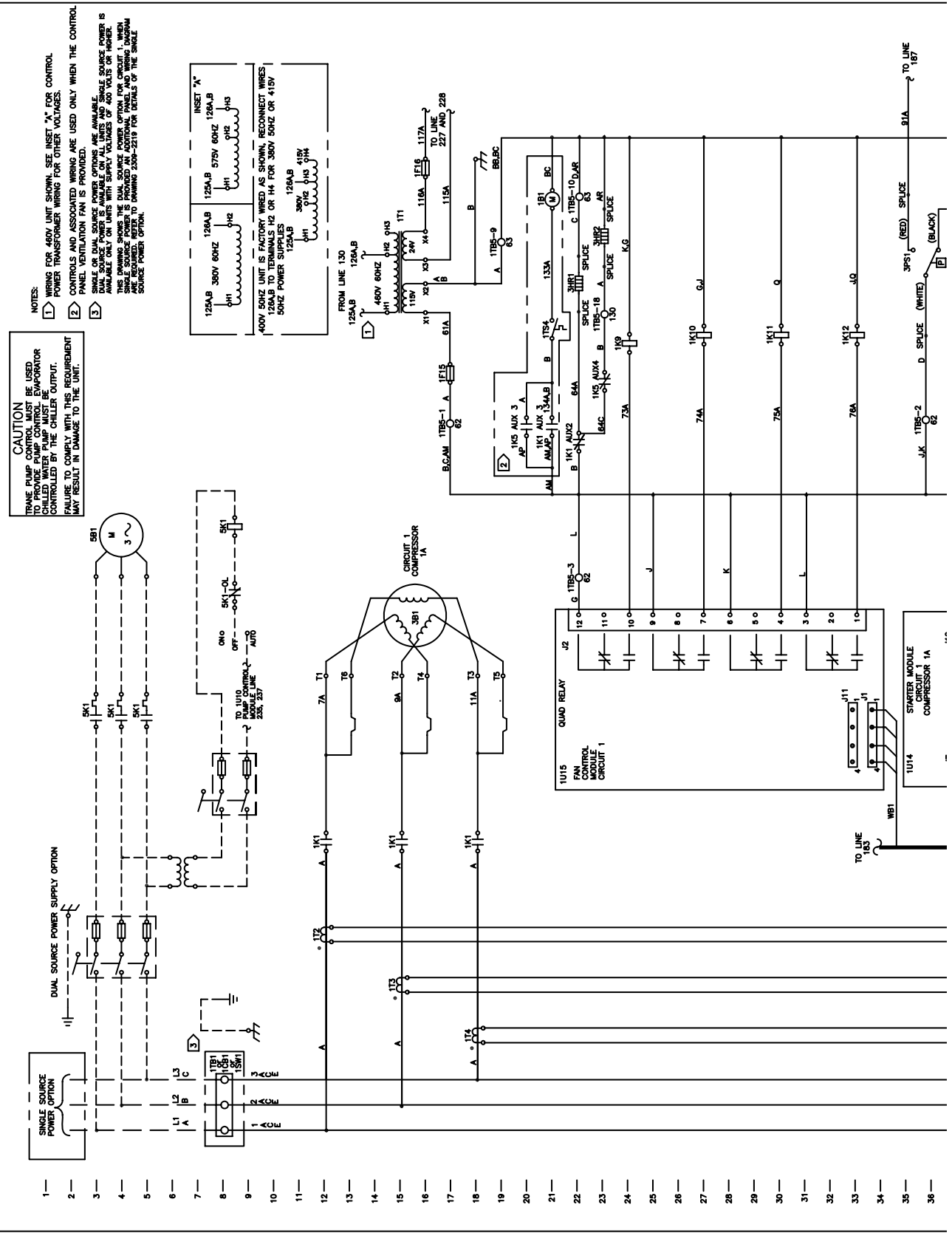
- WIRING REQUIREMENTS**
- RECOMMENDED FIELD WIRING CONNECTIONS ARE SHOWN BY DOTTED LINES.
  - ALL FIELD WIRING MUST BE IN ACCORDANCE WITH THE NATIONAL ELECTRICAL CODE (NEC) AND ALL LOCAL APPLICABLE CODES.
  - ALL UNIT WIRING MUST BE COPPER CONDUCTORS ONLY AND 12 AWG. ALL FIELD WIRING MUST BE COPPER CONDUCTORS ONLY AND 12 AWG. THE HEAT TAPE AND/OR CONVEGENCE OUTLET AND THE #10 SET SCREW WHICH WILL ACCEPT RING OR FORK TERMINALS OR THE FOLLOWING MAXIMUM RUN LENGTHS FOR A GIVEN SIZE: 14 AWG, 10 FT; 12 AWG, 16 FT; 10 AWG, 25 FT; 8 AWG, 40 FT; 6 AWG, 60 FT; 4 AWG, 100 FT.
  - SHIELDED TRINITEC PAIR LEADS ARE REQUIRED FOR CONNECTIONS TO SHIELD SHOULD BE GROUNDING AT THE FACTOR CONTROL PANEL END.
  - THE CONTACTS FOR THESE FEATURES ARE JAMPERS AT THE FACTOR CONTROL PANEL. IT IS DESIRED REMOVE THE JAMPERS AND CONNECT TO THE FACTOR CONTROL PANEL.
  - AS SHIPPED THE NORMAL 400 VOLT UNIT CONTROL POWER TRANSFER LEADS 10A & 10B SHOULD BE RECONNECTED TO THE APPROPRIATE FACTOR CONTROL PANEL.
  - GROUND ALL CUSTOMER PROVIDED 115 VOLT POWER SUPPLIES AS PER LOCAL ELECTRICAL CODES.
- CONTACT INTENS AND REQUIREMENTS**
- UNIT PROVIDED DRY CONTACTS FOR THE EVAPORATOR PUMP CONTROL STATUS RELAY (1U10, 1U13, & 1U15) ARE RATED FOR 7.2 AMPS RESISTIVE LOADS. THE RATED FOR 5 AMPS GENERAL PURPOSE DRY AT :
  - CUSTOMER SUPPLIED CONTACTS FOR ALL LOW VOLTAGE CONNECTIONS FOR A 12 IN RESISTIVE LOAD SHOWN ON GOLD PLATED CONTACTS AT :
  - FUSE SWITCH AND INTERLOCK CONTACTS MUST BE ACCEPTABLE FOR :
  - THE FIELD PROVIDED INDICATORS MAY BE RELAYS (AS SHOWN), LIGHTS, OR BELL SIGNALS. THE DUPLICATE FUNCTIONS MAY BE COMPLETED BY EITHER OR BOTH OF EACH OF THE 4 SPOT RELAYS ON THE OPTIONAL UNIT OPERATING STATUS MODULE. THE FUNCTIONS OF THE OPERATING STATUS MODULE RELAYS ARE PER :

REPLACEMENT FUSE SIZES						
FUSE PROTECT FUNCTION	UNIT SIZE	UNIT VOLTAGE	DESIGNATION	VOLTS	CLASS	AMPS
CONTROL POWER TRANSFORMER PRIMARY	280 TO 300	ALL	1F1-1F6/1F3-1F8/2F1-2F4/2F3-2F8	250	CE	25
		200/240	1F3/1F4/2F3/2F4	250	CE	25
		330/360		250	CE	6
		480/540		250	CE	3.5
CONTROL POWER TRANSFORMER 115 VOLT SEC.	ALL	200/240	1F15/2F15	250	CE	6
		330/360	1F14/2F14	250	CE	6
		480/540		250	CE	6
		575/630		250	CE	6
CONTROL POWER TRANSFORMER 24 VOLT SEC.	ALL	200/240	1F12/2F12	250	CE	10
		330/360	1F11/2F11	250	CE	10
EVAPORATOR HEAT AND OR HEATER TRANSFORMER PRI.	280/300/350/360	240/280/330/360	1F12-1F22/2F12-2F22	250	CE	10
		575/630		250	CE	6.25

REVISION	AUTOCAD	2309-2223	REV
REVISION DATE	DATE	DESCRIPTION	BY
4-8-01	04/08/01	FIELD WIRING	EE
11-27-00	11/27/00	LARGE AIR COOLED UNITS WITH 3 OR 4 COMPRESSORS	EE



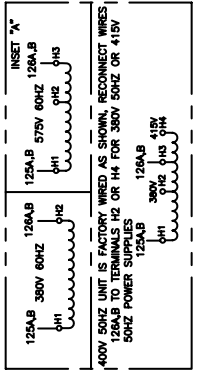
- WIRING REQUIREMENTS**
5. RECOMMENDED FIELD WIRING CONNECTIONS ARE SHOWN BY DOTTED LINES
  6. ALL FIELD WIRING MUST BE IN ACCORDANCE WITH THE NATIONAL ELECTRIC CODE AND STATE AND LOCAL REQUIREMENTS. EXPORT UNIT WIRING MUST COMPLY WITH LOCAL APPLICABLE CODES.
  7. ALL UNIT POWER WIRING MUST BE COPPER CONDUCTORS ONLY AND HAVE A MINIMUM TEMPERATURE INSULATION RATING OF 90 DEGREES C. SEE UNIT MANUALS FOR MINIMUM CIRCUIT AMPACITY AND MAXIMUM FUSE SIZE REQUIREMENTS. THE POWER WIRING WIRE SIZE PROVIDED ON THE VARIOUS UNITS IS SHOWN ON DRAWING 2309-2244.
  8. ALL CUSTOMER CONTROL CIRCUIT WIRING MUST BE COPPER CONDUCTORS ONLY AND HAVE A MINIMUM INSULATION RATING OF 300 VOLTS. EXCEPT AS NOTED ALL CUSTOMER WIRING CONNECTIONS ARE MADE TO CIRCUIT BOARD MOUNTED BOX LUGS WITH A WIRE RANGE OF 14 TO 18 AWG. THE WIRE TAPE AND/OR CONDUIT OUTLET AND THE GROUND SIDE OF THE FLOW SWITCH GO TO TERMINAL STRIPS WITH A #10 SET SCREW WHICH WILL ACCEPT RING OR PONY TERMINALS OR STRIPPED WIRE LEADS.
  9. DO NOT RUN LOW VOLTAGE CONTROL WIRING (90 VOLTS OR LESS) IN CONDUIT WITH 110 VOLT OR HIGHER WIRING. DO NOT EXCEED THE FOLLOWING MAXIMUM RUN LENGTHS FOR A GIVEN SIZE: 14 AWG, 3000 FT; 16 AWG, 2000 FT; 18 AWG, 1000 FT.
  10. CHASSIS GROUND WIRE LEADS ARE PROVIDED FOR CONNECTIONS TO THE COMMUNICATIONS INTERFACE MODULE (114). THE SHIELD SHOULD BE GROUNDING AT THE RTAC CONTROL PANEL END.
  11. THE CONTACTS FOR THESE FEATURES ARE JAMPERS AT THE FACTORY BY JAMPERS W1 & W2 TO ENABLE UNIT OPERATION. IF REMOTE CONTROL IS DESIRED REMOVE THE JAMPERS AND CONNECT TO THE DESIRED CONTROL CIRCUIT.
  12. AS SHOWN THE NORMAL AND HOLD UNIT CONTROL POWER TRANSFORMERS ARE WIRING ON THE 240 VOLT TAP (W2). TRANSFORMER LEADS 128A & 128B SHOULD BE RECONNECTED TO THE APPROPRIATE TAP FOR THE 380 (W3) OR 415 (W4) VOLT POWER SUPPLIES.
  13. GROUND ALL CUSTOMER PROVIDED 115 VOLT POWER SUPPLIES AS REQUIRED BY CODES. GREEN GROUND SCREWS ARE PROVIDED IN THE UNIT CONTROL PANEL.
- CONTACT RATINGS AND REQUIREMENTS**
14. UNIT PROVIDED DRY CONTACTS FOR THE EVAPORATOR PUMP CONTROL, THE UNIT OPERATING STATUS RELAYS & THE ICE MAKING STATUS RELAY (1110, 1115 & 1113) ARE RATED FOR 7.2 AMPS RESISTIVE, 2.88 AMPS INDUCTIVE, OR 1/3 HP, 7.2 FLA AT 120 VOLTS 60 HZ. CONTACTS ARE RATED FOR 8 AMPS GENERAL PURPOSE DUTY AT 240 VOLTS. THE MAX FUSE SIZE FOR ANY OF THESE CIRCUITS IS 15 AMPS.
  15. CUSTOMER SUPPLIED CONTACTS FOR ALL LOW VOLTAGE CONNECTIONS MUST BE COMPATIBLE WITH DRY CIRCUIT 24 VOLTS DC FOR A 15 mA RESISTIVE LOAD. SILVER OR GOLD PLATED CONTACTS ARE RECOMMENDED.
  16. FLOW SWITCH AND INTERLOCK CONTACTS MUST BE ACCEPTABLE FOR USE IN A 120 VOLT 1mA CIRCUIT, OR A 250 VOLT 2mA CIRCUIT.
  17. THE FIELD PROVIDED INDICATORS MAY BE RELAYS (AS SHOWN), LIGHTS OR ALARMS DEVICES. FOUR DUPLICATE FUNCTIONS ARE SHOWN. THE DUPLICATE FUNCTIONS MAY BE COMBINED TO EITHER OR BOTH OF THE NORMALLY OPEN OR NORMALLY CLOSED RELAY CONTACTS OF EACH OF THE 4 SPST RELAYS ON THE OPTIONAL UNIT OPERATING STATUS MODULE.
- THE FUNCTIONS OF THE OPERATING STATUS MODULE RELAYS ARE PROGRAMMABLE. DEFAULT FUNCTIONS ARE SHOWN. SEE IOM FOR DETAILS.



**CAUTION**  
 TRANE PUMP CONTROLS MUST BE USED TO PROVIDE PROPER WATER FLOW. FAILURE TO COMPLY WITH THIS REQUIREMENT MAY RESULT IN DAMAGE TO THE UNIT.

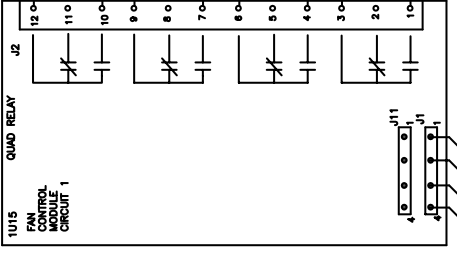
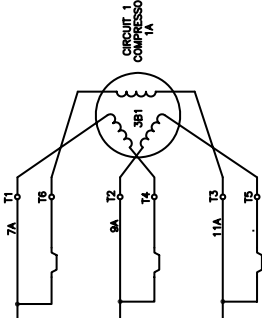
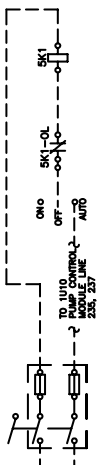
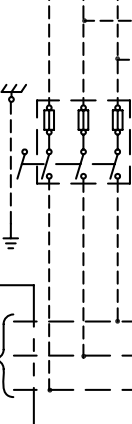
- NOTES:
- 1 WIRING FOR 460V UNIT SHOWN. SEE INSET "A" FOR CONTROL PUMP TRANSFORMER WIRING FOR OTHER VOLTAGES.
  - 2 CONTROLS AND ASSOCIATED WIRING ARE USED ONLY WHEN THE CONTROL PANEL VENTILATION FAN IS PROVIDED.
  - 3 SINGLE OR DUAL SOURCE POWER OPTIONS ARE AVAILABLE.

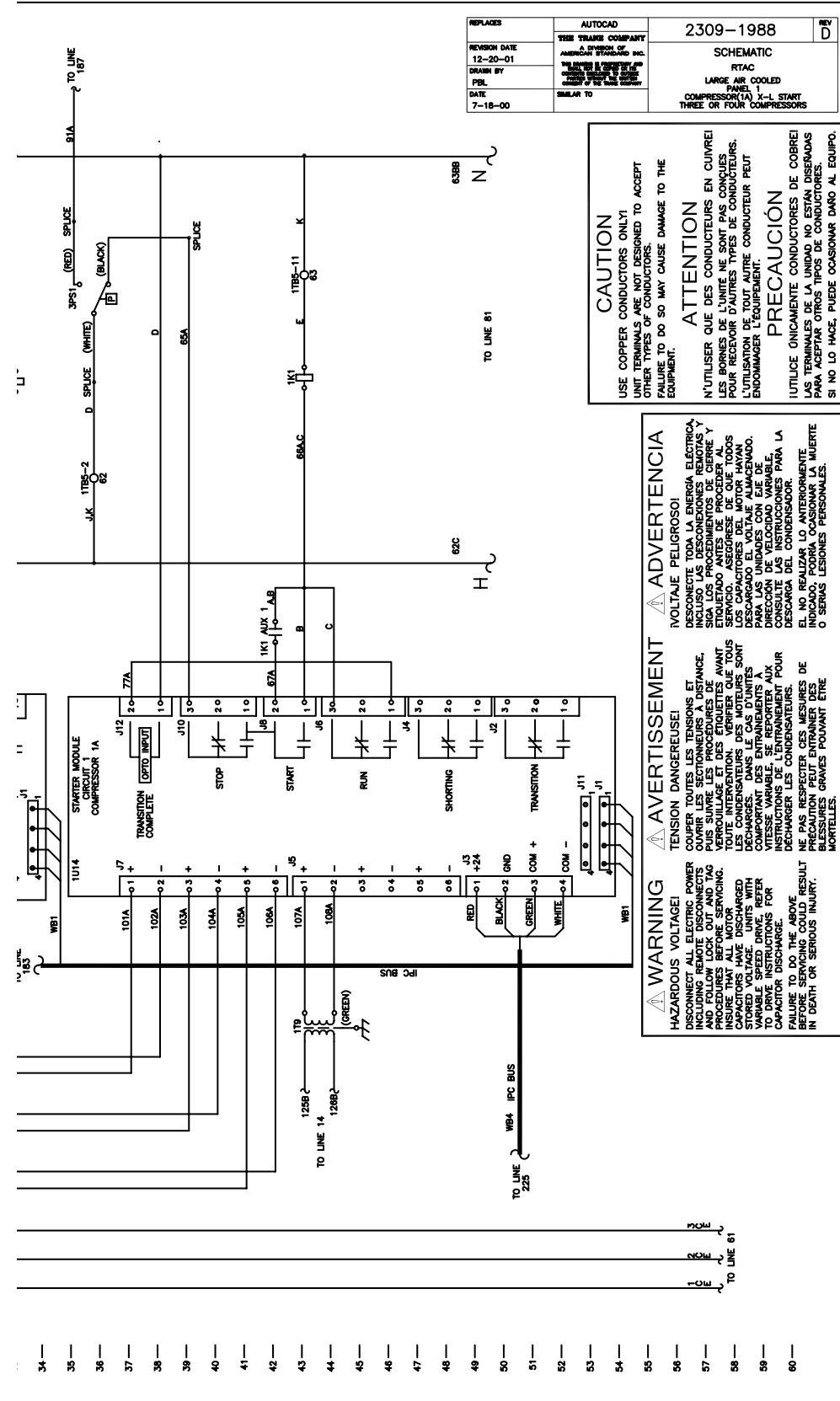
DUAL SOURCE POWER IS AVAILABLE ON ALL UNITS AND SINGLE SOURCE POWER IS AVAILABLE ON ALL UNITS. THIS DRAWING SHOWS THE DUAL SOURCE POWER OPTION FOR CIRCUIT 1. WHEN SINGLE SOURCE POWER IS PROVIDED AN ADDITIONAL PANEL AND WIRING DIAGRAM MUST BE PROVIDED TO DRAWING 230P-2519 FOR DETAILS OF THE SINGLE SOURCE POWER OPTION.



460V 50HZ UNIT IS FACTORY WIRED AS SHOWN. RECONNECT WIRES 125A,B TO TERMINALS H2 OR H4 FOR 380V 50HZ OR 415V 50HZ POWER SUPPLIES.

DUAL SOURCE POWER SUPPLY OPTION





REPLACES	AUTOCAD	2309-1988	D
REVISION DATE	THE TRANE COMPANY A DIVISION OF AMERICAN STANDARD INC. 11000 W. CENTER ST. MILWAUKEE, WIS. 53224 TEL. 414-771-1000 FAX 414-771-1001	SCHEMATIC	
DESIGNED BY	PER	RTAC	
DATE	7-18-00	LARGE AIR COOLED COMPRESSOR PANEL 1 - ALL START THREE OR FOUR COMPRESSORS	

**CAUTION**  
USE COPPER CONDUCTORS ONLY!  
UNIT TERMINALS ARE NOT DESIGNED TO ACCEPT  
OTHER TYPES OF CONDUCTORS.  
FAILURE TO DO SO MAY CAUSE DAMAGE TO THE  
EQUIPMENT.

**ATTENTION**  
N'UTILISER QUE DES CONDUCTEURS EN CUIVRE!  
LES BORNES DE L'UNITÉ NE SONT PAS CONÇUES  
POUR RECEVOIR D'AUTRES TYPES DE CONDUCTEURS.  
L'UTILISATION DE TOUT AUTRE CONDUCTEUR PEUT  
ENDOMMAGER L'ÉQUIPEMENT.

**PRECAUCIÓN**  
¡UTILICE ÚNICAMENTE CONDUCTORES DE COBRE!  
LAS TERMINALES DE LA UNIDAD NO ESTÁN DISEÑADAS  
PARA ACEPTAR OTROS TIPOS DE CONDUCTORES.  
SI NO LO HACE, PUEDE OCASIONAR DAÑO AL EQUIPO.

**WARNING** ⚠️ **AVERTISSEMENT** ⚠️ **ADVERTENCIA** ⚠️

**HAZARDOUS VOLTAGE!**  
DISCONNECT ALL ELECTRIC POWER  
INCLUDING REMOTE DISCONNECTS  
BEFORE SERVICING.  
INSURE THAT ALL MOTOR  
CAPACITORS HAVE DISCHARGED  
BEFORE SERVICING.  
VARIABLE SPEED DRIVERS FOR  
CAPACITOR DISCHARGE.

**TENSION DANGEREUSE!**  
COUPER TOUTES LES TENSIONS ET  
OUVRIER LES SECTIONNEURS À DISTANCE,  
AVANT LE SERVICE.  
VÉRIFIER QUE TOUTES LES  
CONDENSATEURS DES MOTEURS SONT  
DÉCHARGÉS AVANT LE SERVICE.  
LES CONDENSATEURS À VITESSE  
VARIABLE SONT À DÉCHARGER  
AVANT LE SERVICE.

**VOLTAJE PELIGROSO!**  
DESCONECTE TODA LA ENERGÍA ELÉCTRICA  
INCLUSO LAS DESCONEXIONES REMOTAS Y  
ETIQUETADO ANTES DE PROCEDER AL  
SERVICIO. ASEGURESE DE QUE TODOS  
LOS CONDENSADORES DEL MOTOR HAYAN  
DESCHARGADO ANTES DEL SERVICIO.  
PARA LAS UNIDADES CON EJE DE  
DIRECCIÓN DE VELOCIDAD VARIABLE,  
DESCARGAR LOS CONDENSADORES PARA LA  
REPARACIÓN DEL EQUIPO.

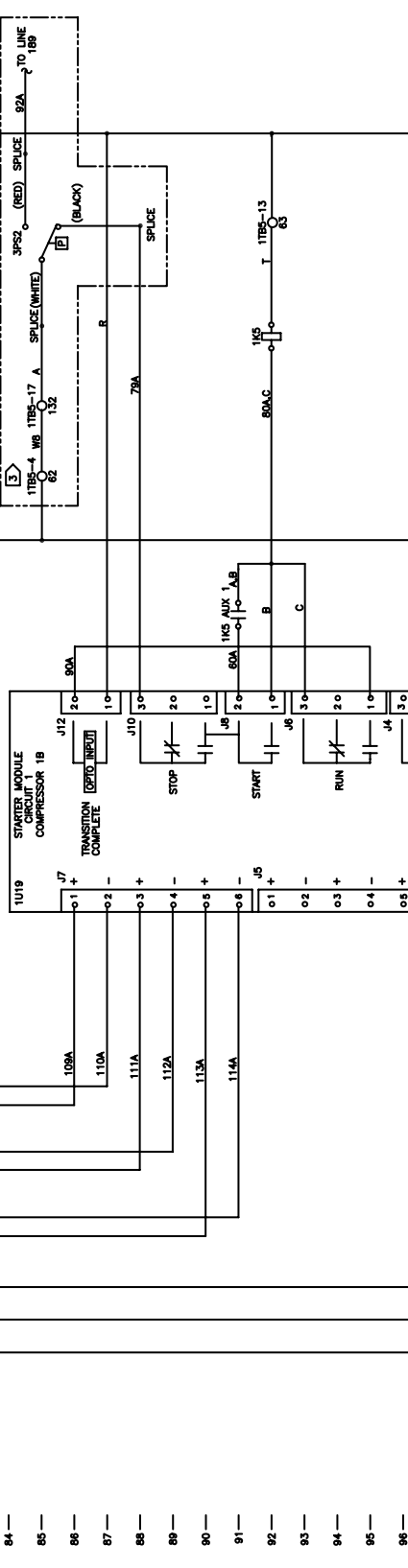
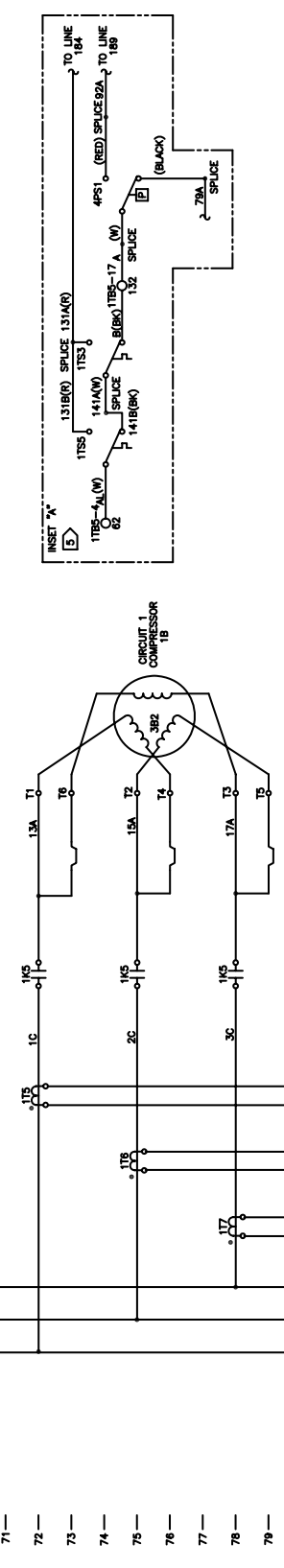
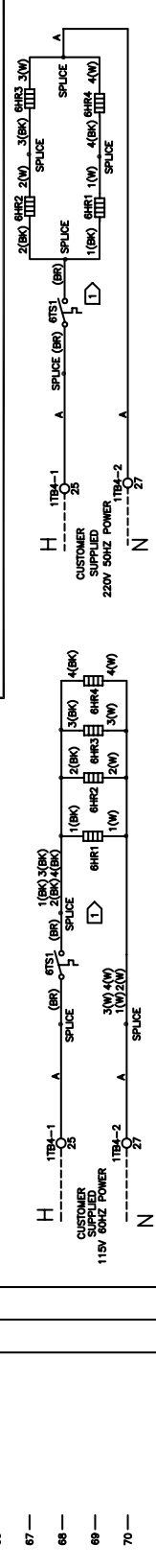
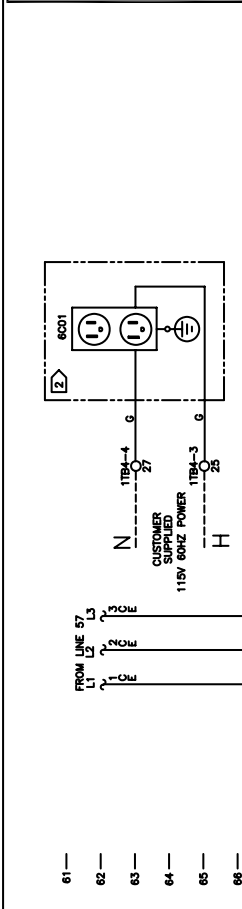
**NE PAS RESPECTER CES MESURES DE  
PRECAUTION PEUT ENTRAINER DES  
BLESSURES GRAVES POUVANT ÊTRE  
MORTELLES.**

**EL NO REALIZAR LO ANTERIORMENTE  
INDICADO, PODRÍA OCASIONAR LA MUERTE  
O SERIAS LESIONES PERSONALES.**

**HAZARDOUS VOLTAGE!**  
DISCONNECT ALL ELECTRIC POWER INCLUDING REMOTE DISCONNECTS AND FOLLOW LOCK OUT AND TAG INSURE THE ALTERNATOR SERVICING. CAPACITORS HAVE DISCHARGED STORED VOLTAGE UNITS WITH TO DRIVE INSTRUCTIONS FOR CAPACITOR DISCHARGE. FAILURE TO DO THE ABOVE BEFORE SERVICING COULD RESULT IN DEATH OR SERIOUS INJURY.

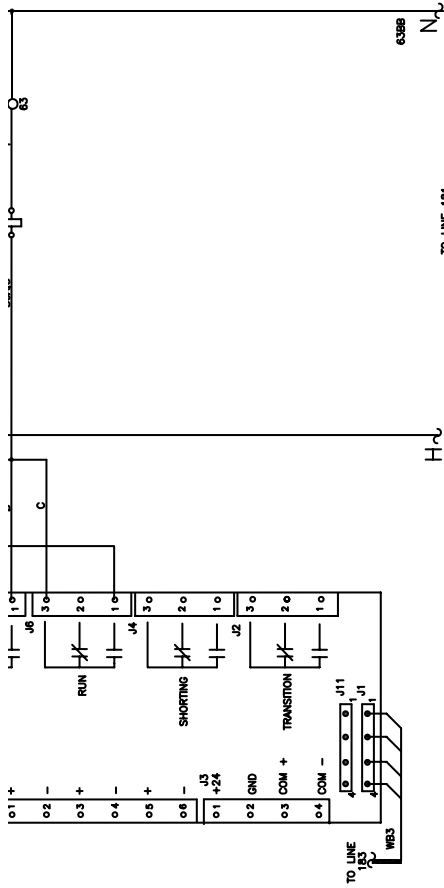
**AVERTISSEMENT DANGEREUX!**  
TENSION TOUTES LES TENSIONS ET OUVRIRE LES SECTIONNEURS A DISTANCE. PLUS SUIVRE LES PROCEDURES DE SAUVEGARDE. TOUJOURS VÉRIFIER QUE TOUS LES CONDENSATEURS DES MOTEURS SONT DÉCHARGÉS. DANS LE CAS D'UNITÉS DE STOCKAGE DE TENSION, SUIVRE LES INSTRUCTIONS POUR LA DÉCHARGE DES CONDENSATEURS. NE PAS RESPECTER CES MESURES DE SÉCURITÉ PEUT CAUSER LA MORT OU DES BLESSURES GRAVES POUVANT ÊTRE MORTELLES.

**ADVERTENCIA**  
VOLTAJE PELIGROSO!  
DESCONECTE TODA LA ENERGÍA ELÉCTRICA INCLUIDO LAS DESCONECCIONES REMOTAS Y SIGA LOS PROCEDIMIENTOS DE CIERRE Y SERVICIO. SIEMPRE VERIFIQUE QUE TODOS LOS CAPACITORES DEL MOTOR HAYAN SIDO DESCARGADOS. EN EL CASO DE UNIDADES DE ALMACENAMIENTO DE TENSION, SIGA LAS INSTRUCCIONES PARA LA DESCARGA DEL CONDENSADOR. EL NO REALIZAR LO ANTERIORMENTE PODRÍA CAUSAR LA MUERTE O SERIAS LESIONES PERSONALES.



- 61 —
- 62 —
- 63 —
- 64 —
- 65 —
- 66 —
- 67 —
- 68 —
- 69 —
- 70 —
- 71 —
- 72 —
- 73 —
- 74 —
- 75 —
- 76 —
- 77 —
- 78 —
- 79 —
- 80 —
- 81 —
- 82 —
- 83 —
- 84 —
- 85 —
- 86 —
- 87 —
- 88 —
- 89 —
- 90 —
- 91 —
- 92 —
- 93 —
- 94 —
- 95 —
- 96 —

92 —  
 93 —  
 94 —  
 95 —  
 96 —  
 97 —  
 98 —  
 99 —  
 100 —  
 101 —  
 102 —  
 103 —  
 104 —  
 105 —  
 106 —  
 107 —  
 108 —  
 109 —  
 110 —  
 111 —  
 112 —  
 113 —  
 114 —  
 115 —  
 116 —  
 117 —  
 118 —  
 119 —  
 120 —



TO LINE 121

REPLACES	AUTOCAD	2309-1989	REV D
REVISION DATE	12-12-01		
DESIGNED BY	THE TRANE COMPANY A DIVISION OF AMERICAN STANDARD INC.		
DATE	7-18-00		
		SCHMATIC	
		RTAC	
		LARGE AIR COOLED	
		PANEL	
		COMPRESSOR(S) X-L START	
		THREE OR FOUR COMPRESSORS	

- NOTES:
- 1) EVAPORATOR HEATER COMPONENTS (R1S1, RHR1, RHR2, RHR3, RHR4 AND ASSOCIATED WIRING ARE PROVIDED WITH THE REMOTE EVAPORATOR OPTION.
  - 2) OPTIONAL CUSTOMER CONVENIENCE OUTLET.
  - 3) UNITS WITHOUT THE CONTROL PANEL VENTILATION FAN ARE WIRED AS SHOWN. SEE INSET "A" FOR WIRING WHEN THE VENTILATION FAN IS PROVIDED.

**CAUTION**

USE COPPER CONDUCTORS ONLY!  
 UNIT TERMINALS ARE NOT DESIGNED TO ACCEPT  
 OTHER TYPES OF CONDUCTORS.  
 FAILURE TO DO SO MAY CAUSE DAMAGE TO THE  
 EQUIPMENT.

**ATTENTION**

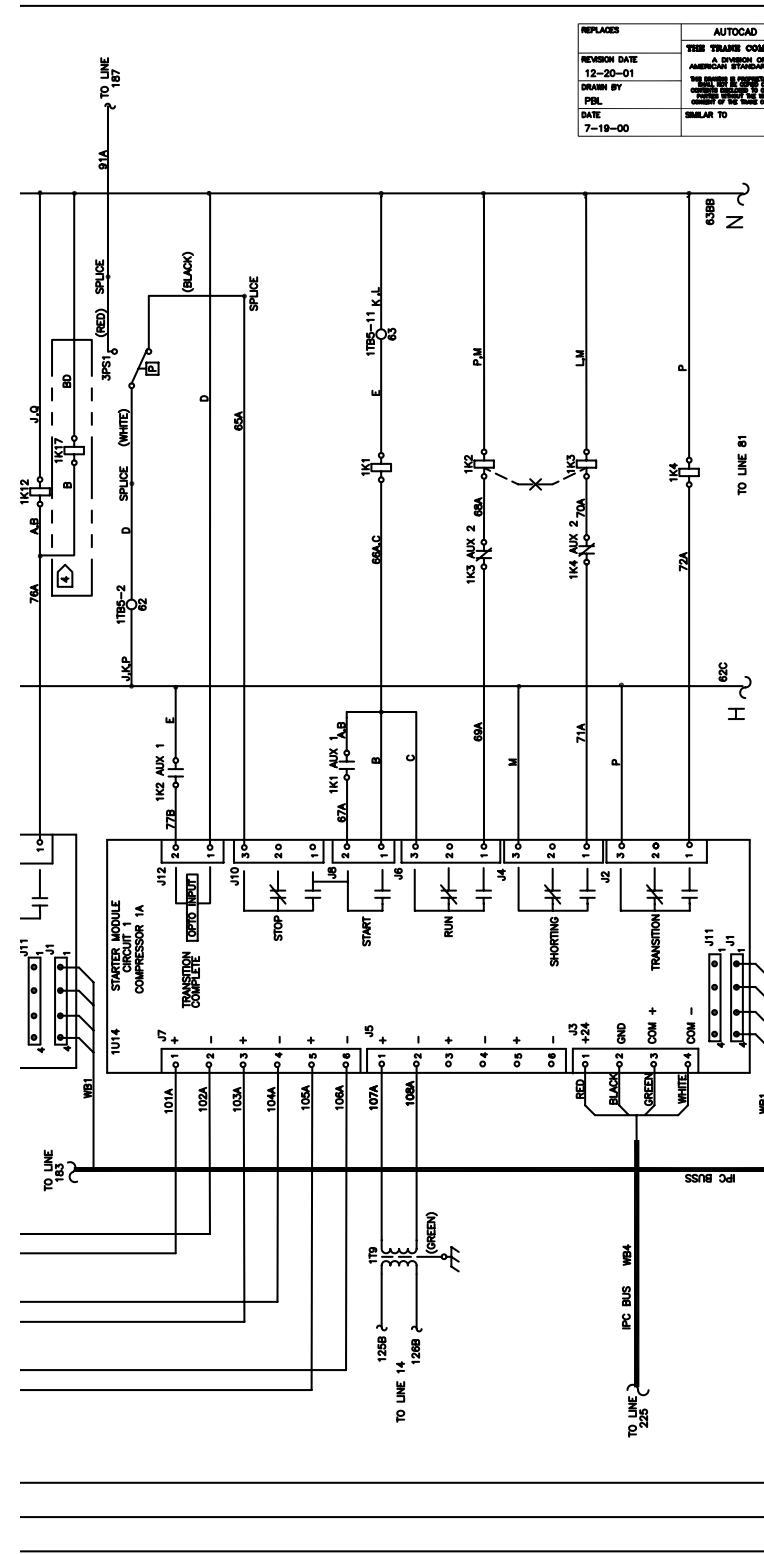
N'UTILISER QUE DES CONDUCTEURS EN CUIVRE!  
 LES TERMINAUX DE LA UNITÉ NE SONT PAS CONÇUS  
 POUR RECEVOIR D'AUTRES TIPIOS DE CONDUCTEURS.  
 L'UTILISATION DE TOUT AUTRE CONDUCTEUR PEUT  
 ENDOMMAGER L'ÉQUIPEMENT.

**PRECAUCIÓN**

¡UTILICE ÚNICAMENTE CONDUCTORES DE COBRE!  
 LAS TERMINALES DE LA UNIDAD NO ESTÁN DISEÑADAS  
 PARA ACEPTAR OTROS TIPOS DE CONDUCTORES.  
 SI NO LO HACE, PUEDE OCASIONAR DAÑO AL EQUIPO.

TO LINE 121





REPLACES	AUTOCAD
REVISION DATE	THE TRANE COMPANY 12-20-01
DRAWN BY	AMERICAN FURNACE & HEATING CO. 11/20/01
DATE	7-19-00
	SIMILAR TO

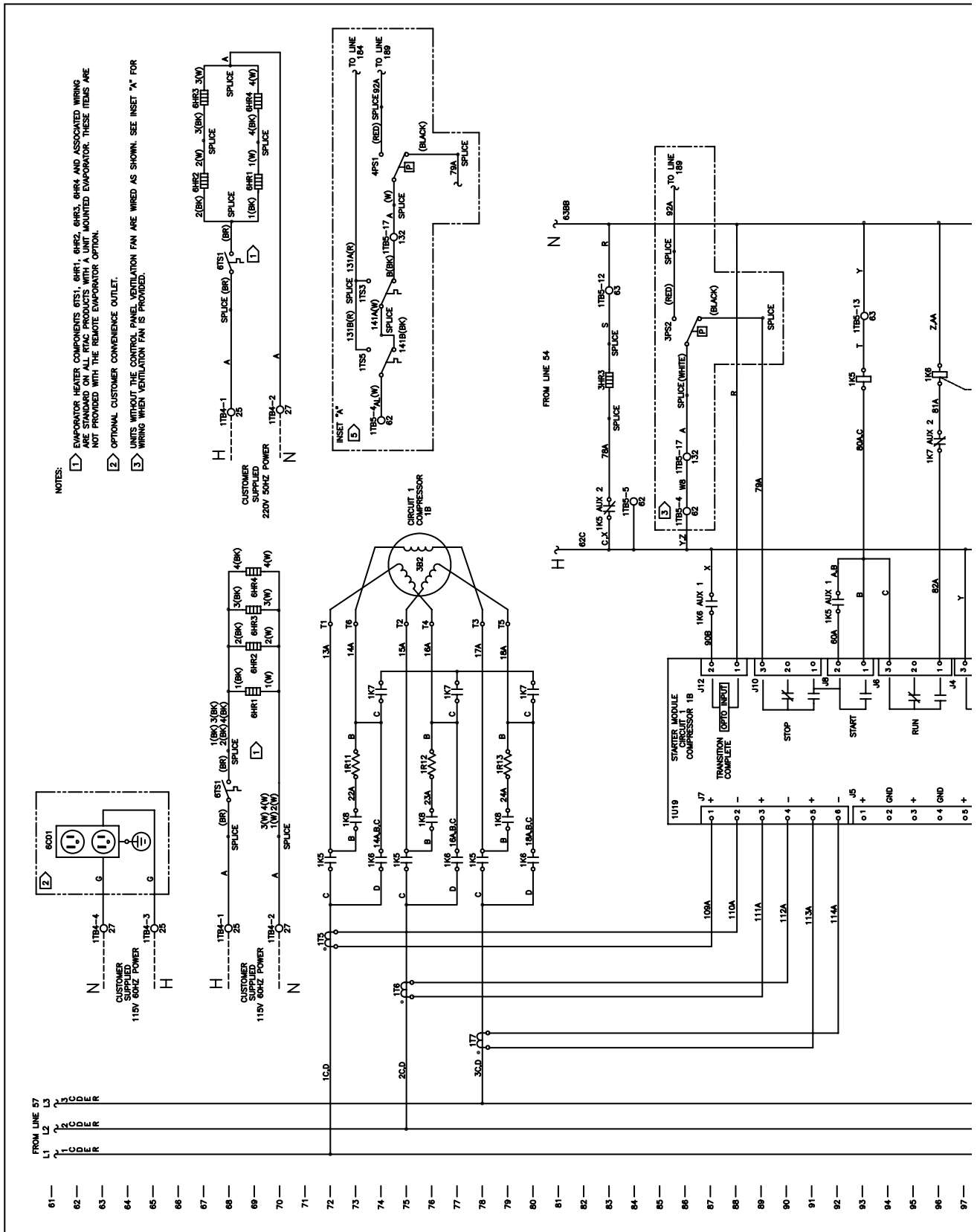
2309-1990	REV
SCHEMATIC	
RTAC	
LARGE AIR COOLED	
PANEL	
COMPRESSOR TYPE-DELTA	
THREE OR FOUR COMPRESSORS	

**HAZARDOUS VOLTAGE!**  
DISCONNECT ALL ELECTRIC POWER INCLUDING REMOTE DISCONNECTS BEFORE SERVICING.  
INSURE THAT ALL MOTOR CAPACITORS HAVE DISCHARGED TO DRIVE INSTRUCTIONS FOR CAPACITOR DISCHARGE.  
FAILURE TO DO THE ABOVE RESULT IN DEATH OR SERIOUS INJURY.

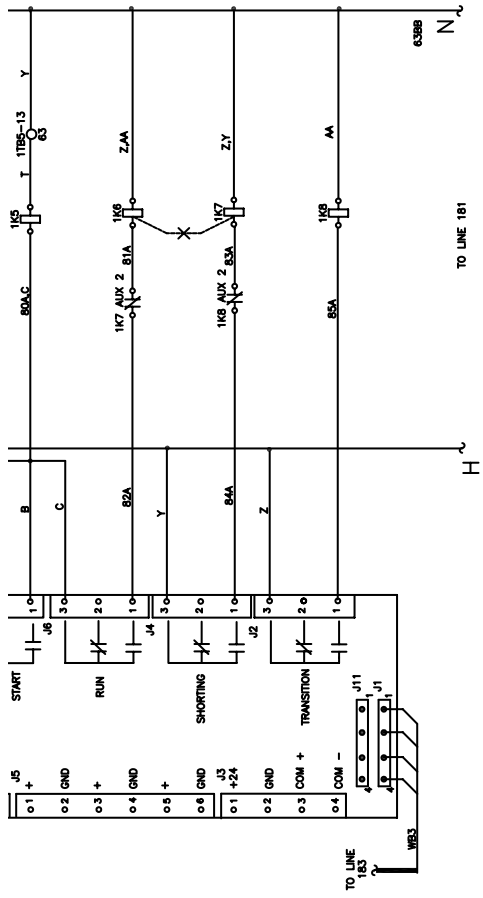
**WARNING**  
TENSION DANGEREUSE!  
COUPER TOUTES LES TENSIONS ET OUVRIER LES SECTIONNEURS A DISTANCE, AVANT DE PROCEDER AU VERROUILLAGE ET DES ETIQUETTES.  
TOUTE INTERVENTION, VERIFIER QUE TOUTS LES CONDENSATEURS DES MOTEURS SONT DECHARGES.  
SE REPORTER AUX INSTRUCTIONS POUR LE DECHARGEMENT DES CONDENSATEURS.  
NE PAS RESPECTER CES MESURES DE PRECAUTION PEUT ENTRAINER DES BLESSURES GRAVES POUVANT ETRE MORTELLES.

**AVVERTISSEMENT**  
¡VOLTAJE PELIGROSO!  
DESCONECTE TODA LA ENERGIA ELECTRICA, INCLUIDO LAS DESCONEXIONES REMOTAS Y LA DESCONEXION DE LOS SECCIONNEURS, ANTES DE PROCEDER AL SERVICIO.  
ASEGURESE DE QUE TODOS LOS CAPACITORES DEL MOTOR HAYAN SIDO DESCARGADOS.  
PARA LAS UNIDADES CON ELE DE DIRECCION DE VELOCIDAD VARIABLE, CONSULTAR LAS INSTRUCCIONES PARA LA DESCARGA DE LOS CONDENSADORES.  
EL NO REALIZAR LO ANTERIORMENTE INDICADO, PODRIA OCASIONAR LA MUERTE O SERIAS LESIONES PERSONALES.

- NOTES:
1. WIRING FOR 460V OR 200V UNIT SHOWN. SEE INSET "A" FOR CONTROL POWER TRANSFORMER WIRING FOR OTHER VOLTAGES.
  2. CONTROLS AND ASSOCIATED WIRING ARE USED ONLY WHEN THE CONTROL PANEL VENTILATION FAN IS PROVIDED.
  3. SINGLE OR DUAL SOURCE POWER OPTIONS ARE AVAILABLE. DUAL SOURCE POWER IS AVAILABLE ON ALL UNITS AND SINGLE SOURCE POWER IS AVAILABLE ON 125B AND 128B TRANSFORMER OPTIONS. THIS DRAWING SHOWS THE SINGLE SOURCE POWER OPTION. FOR MORE DETAILS ON THIS OPTION, REFER TO DRAWING 2309-2219 FOR DETAILS OF THE SINGLE SOURCE POWER OPTION.
  4. CONTROLS KIT 7 & ASSOCIATED WIRING ARE USED ONLY ON 275 TON OR LARGER UNITS. REFER TO DRAWING 2309-4079 NOTE 1 FOR DETAILS ON ITS USE.



83 —  
84 —  
85 —  
86 —  
87 —  
88 —  
89 —  
90 —  
91 —  
92 —  
93 —  
94 —  
95 —  
96 —  
97 —  
98 —  
99 —  
100 —  
101 —  
102 —  
103 —  
104 —  
105 —  
106 —  
107 —  
108 —  
109 —  
110 —  
111 —  
112 —  
113 —  
114 —  
115 —  
116 —  
117 —  
118 —  
119 —  
120 —



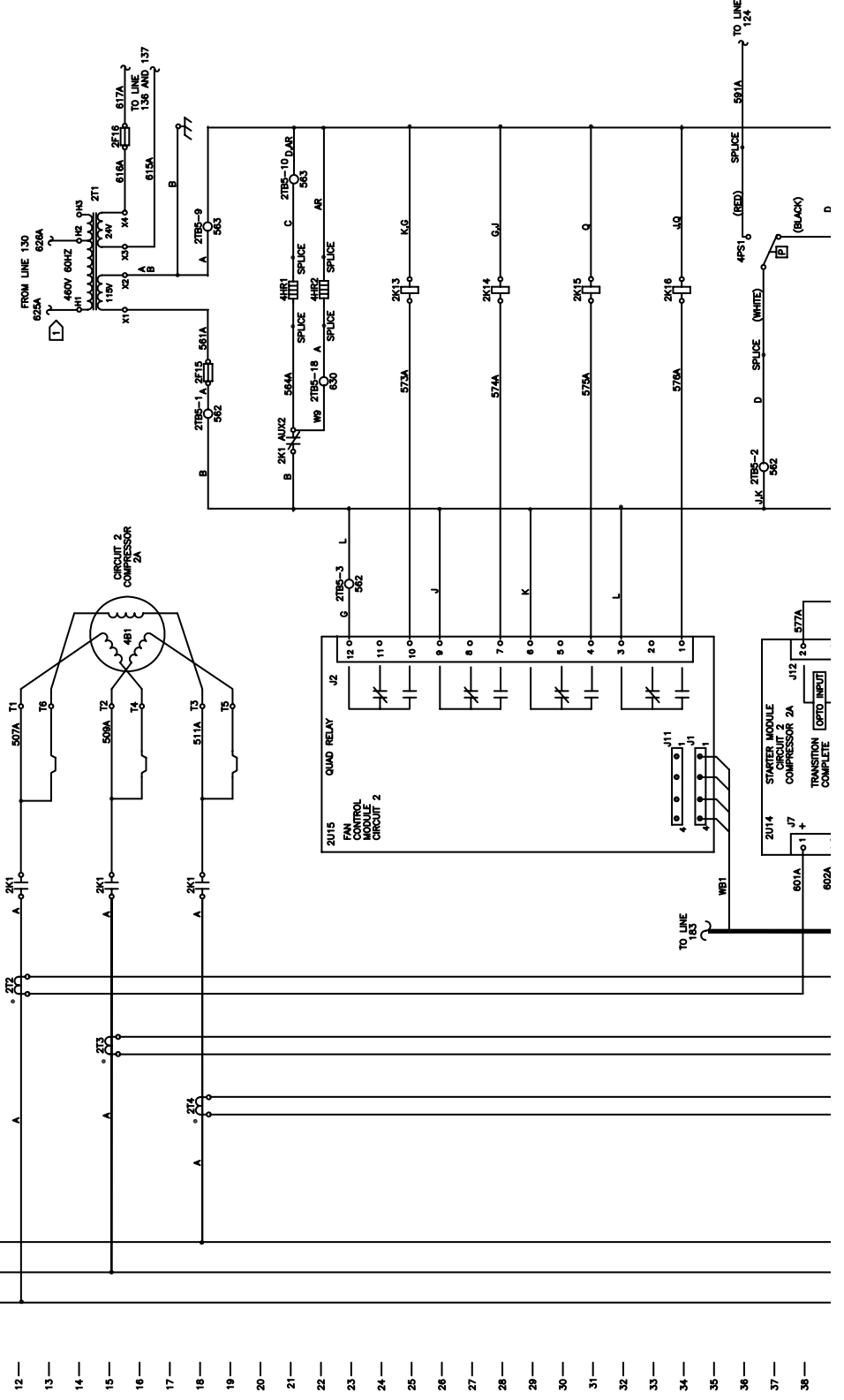
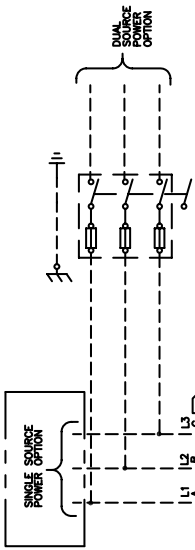
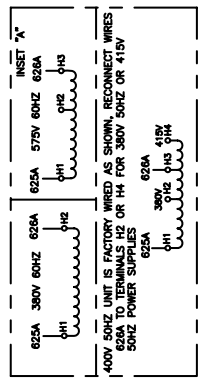
REPLACES	AUTOCAD	2309-1991	REV
REVISION DATE	THIS TRANE COMPANY		D
12-12-01	AMERICAN STANDARD OF		
DRAWN BY	TRANE TRANE COMPANY		
FBL	AMERICAN STANDARD OF		
DATE	SIMILAR TO		
7-19-00			

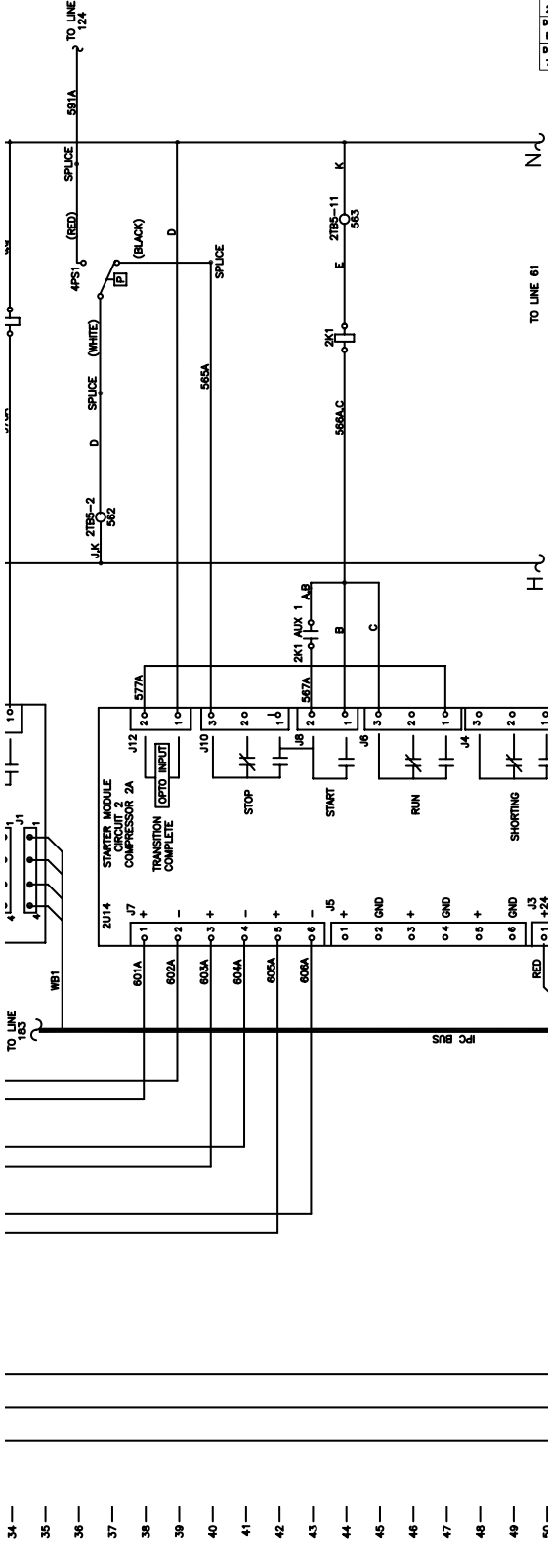
SCHEMATIC  
RTAC  
LARGE AIR COOLED  
COMPRESSOR (18)  
PAGE 1  
WYE-DELTA START  
THREE OR FOUR COMPRESSORS

**WARNING** ⚠️ **AVERTISSEMENT** ⚠️ **ADVERTENCIA** ⚠️  
HAZARDOUS VOLTAGE! TENSION DANGEREUSE! VOLTAGE PELIGROSO!  
DISCONNECT ALL ELECTRIC POWER INCLUDING REMOTE DISCONNECTS AND FUSES EACH TIME BEFORE SERVICING. TOUVER LE CIRCUIT DÉBRANCHÉ ET DÉBRANCHER LES SECTIONNEURS À DISTANCE, Y COMPRIS LES SECTIONNEURS REMOTS, À CHAQUE FOIS AVANT TOUTE INTERVENTION. DESCONECTE TODA LA ENERGIA ELECTRICA, INCLUIDO LAS DESCONEXIONES REMOTAS Y FUSIBLES, EN CADA MOMENTO ANTES DE PROCEDER AL SERVICIO. ASEGURESE DE QUE TODOS LOS CAPACITORES DEL MOTOR HAYAN SIDO DESCARGADOS Y REPERCUSION PARA LAS UNIDADES CON ELE DE DIRECCION DE VELOCIDAD VARIABLE. CONSULTA LAS INSTRUCCIONES PARA LA DRECCION DE VELOCIDAD VARIABLE. EL NO REALIZAR LO ANTERIORMENTE INICADO, PODRIA OCASIONAR LA MUERTE O SERIAS LESIONES PERSONALES.

**CAUTION** ⚠️ **PRECAUCIÓN** ⚠️ **ATTENTION** ⚠️  
USE COPPER CONDUCTORS ONLY! UNIT TERMINALS ARE NOT DESIGNED TO ACCEPT OTHER TYPES OF CONDUCTORS. FAILURE TO DO SO MAY CAUSE DAMAGE TO THE EQUIPMENT.  
N'UTILISER QUE DES CONDUCTEURS EN CUIVRE! LAS BORNES DE L'UNITÉ NE SONT PAS CONÇUES POUR RECEVOIR D'AUTRES TYPES DE CONDUCTEURS. SI NO LO HACE, PUEDE OCASIONAR DAÑO AL EQUIPO.  
UTILICE ÚNICAMENTE CONDUCTORES DE COBRE! LAS TERMINALES DE LA UNIDAD NO ESTÁN DISEÑADAS PARA ACEPTAR OTROS TIPOS DE CONDUCTORES.

NOTES:  
 1 WIRING FOR 460V 60HZ UNIT SHOWN SEE INSET "A" FOR CONTROL POWER TRANSFORMER WIRING FOR OTHER VOLTAGES.  
 2 SINGLE OR DUAL SOURCE POWER OPTIONS ARE AVAILABLE. AVAILABLE ONLY ON UNITS WITH SUPPLY VOLTAGES OF 400 VOLTS OR HIGHER. THIS DRAWING SHOWS THE DUAL SOURCE POWER OPTION FOR CIRCUIT 2. WHEN SINGLE SOURCE POWER IS PROVIDED AN ADDITIONAL PANEL AND WIRING DIAGRAM ARE REQUIRED. REFER TO DRAWING 2309-2219 FOR DETAILS OF THE SINGLE SOURCE POWER OPTION.





REPLACES	AUTOCAD	2309-1996	REV
REVISION DATE	THE TRANE COMPANY		C
7-5-01	AMERICAN POWER INC.		
DRAWN BY	THE TRANE COMPANY		
P.B.L.	AMERICAN POWER INC.		
DATE	7-31-00		
		SCHMATIC	
		RTAC	
		LARGE AIR COOLED	
		COMPRESSOR(2A) X-L-1 START	
		PANEL 2	
		THREE COMPRESSORS	

**CAUTION**  
USE COPPER CONDUCTORS ONLY!  
OTHER TYPES OF CONDUCTORS DESIGNED TO ACCEPT  
FAILURE TO DO SO MAY CAUSE DAMAGE TO THE  
EQUIPMENT.

**ATTENTION**  
N'UTILISER QUE DES CONDUCTEURS EN CUIVRE!  
LES BORNES DE L'UNITÉ NE SONT PAS CONÇUES  
POUR RECEVOIR D'AUTRES TYPES DE CONDUCTEURS.  
L'UTILISATION DE TOUT AUTRE CONDUCTEUR PEUT  
ENDOMMAGER L'ÉQUIPEMENT.

**PRECAUCIÓN**  
UTILICE ÚNICAMENTE CONDUCTORES DE COBRE!  
LAS TERMINALES DE LA UNIDAD NO ESTÁN DISEÑADAS  
PARA ACEPTAR OTROS TIPOS DE CONDUCTORES.  
SI NO LO HACE, PUEDE OCASIONAR DAÑO AL EQUIPO.

**AVERTISSEMENT**  
TENSION DANGEREUSE!  
Ouvrir toutes les tensions et  
plus suivre les procédures de  
toute intervention. Vérifier que  
les condensateurs des moteurs sont  
déchargés. Dans le cas d'unités  
à vitesse variable, se reporter aux  
instructions de l'entraînement pour  
décharger les condensateurs.

**ADVERTENCIA**  
¡VOLTAJE PELIGROSO!  
DESCONECTE TODA LA ENERGÍA ELÉCTRICA  
INCLUSO LAS DESCONEXIONES REMOVIDAS  
SIGA LOS PROCEDIMIENTOS DE CIERRE Y  
SEGURIDAD ANTES DE QUE TOQUE  
LOS CAPACITORES DEL MOTOR HAYAN  
DESCARGADO EL VOLTAJE ALMACENADO.  
EN CASO DE UNIDADES A VELOCIDAD VARIABLE,  
CONSULTE LAS INSTRUCCIONES PARA LA  
DESCARGA DEL CONDENSADOR.

EL NO REALIZAR LO ANTERIORMENTE  
PUEDE CAUSAR LESIONES PERSONALES,  
O SERIAS LESIONES PERSONALES.

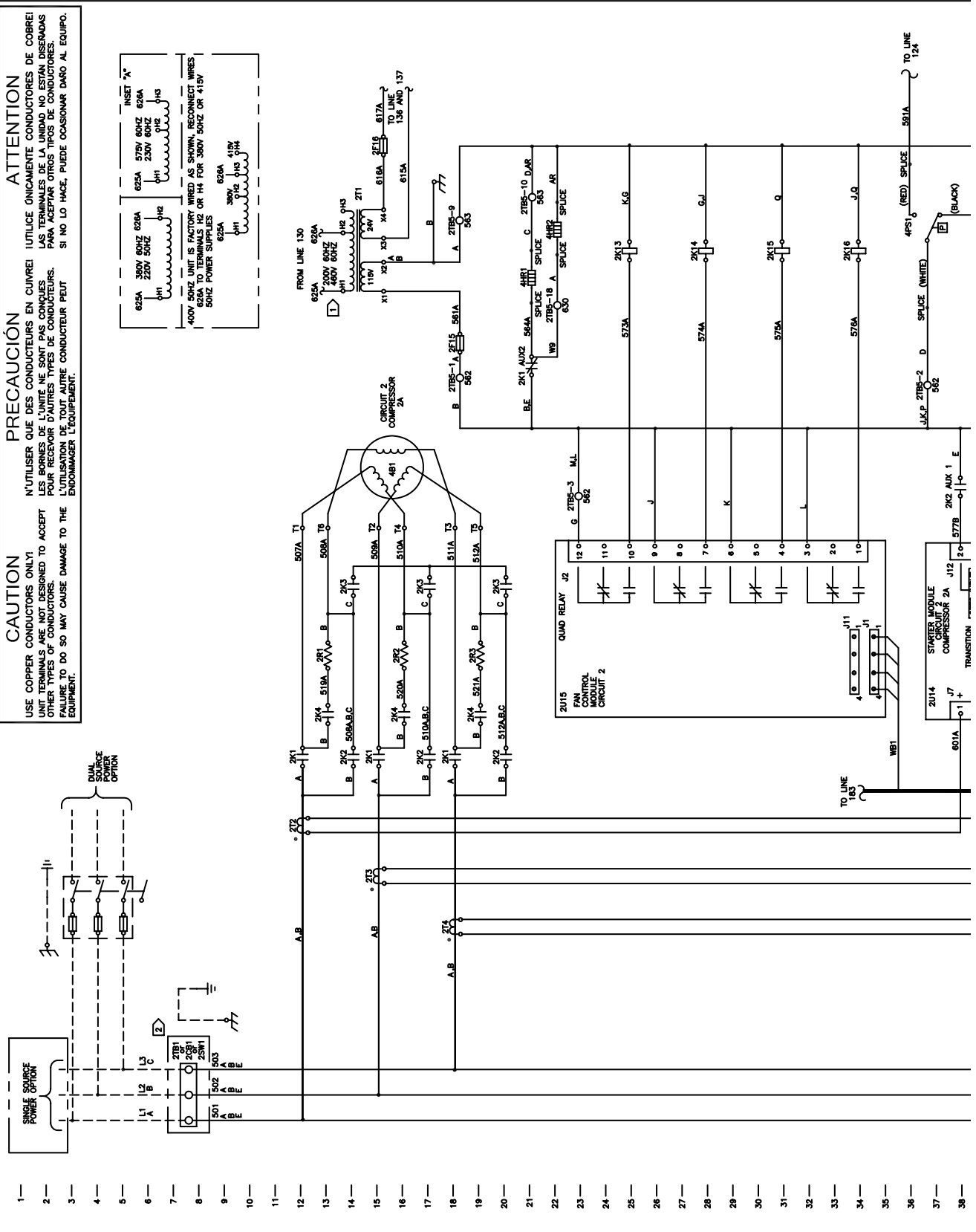
**WARNING**  
HAZARDOUS VOLTAGE!  
DISCONNECT ALL ELECTRIC POWER  
INCLUDING REMOTE DISCONNECTS  
AND FOLLOW LOCK OUT AND TAG  
PROCEDURES BEFORE ANY SERVICE.  
INSURE THAT BEFORE ANY SERVICE  
CAPACITORS HAVE DISCHARGED  
STORED VOLTAGE. UNITS WITH  
VARIABLE SPEED DRIVES REFER  
TO DRIVE INSTRUCTIONS FOR  
CAPACITOR DISCHARGE.

NE PAS RESPECTER CES MESURES DE  
SECURITE AVANT DE FAIRE DES  
BLESSES GRAVES POUVANT ETRE  
MORTELLES.

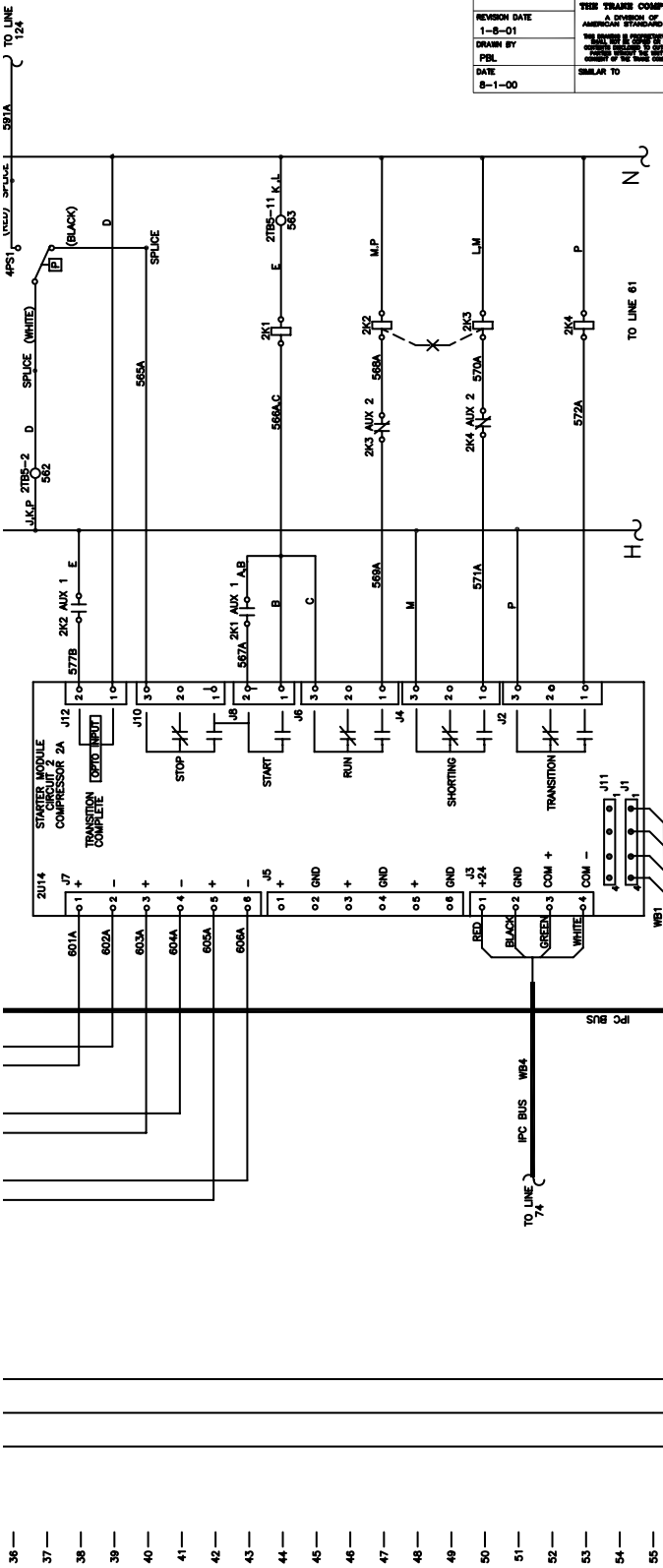
**WARNING**  
HAZARDOUS VOLTAGE!  
DISCONNECT ALL ELECTRIC POWER  
INCLUDING REMOTE DISCONNECTS  
AND FOLLOW LOCK OUT AND TAG  
PROCEDURES BEFORE ANY SERVICE.  
INSURE THAT BEFORE ANY SERVICE  
CAPACITORS HAVE DISCHARGED  
STORED VOLTAGE. UNITS WITH  
VARIABLE SPEED DRIVES REFER  
TO DRIVE INSTRUCTIONS FOR  
CAPACITOR DISCHARGE.

NE PAS RESPECTER CES MESURES DE  
SECURITE AVANT DE FAIRE DES  
BLESSES GRAVES POUVANT ETRE  
MORTELLES.

- 34 —
- 35 —
- 36 —
- 37 —
- 38 —
- 39 —
- 40 —
- 41 —
- 42 —
- 43 —
- 44 —
- 45 —
- 46 —
- 47 —
- 48 —
- 49 —
- 50 —
- 51 —
- 52 —
- 53 —
- 54 —
- 55 —
- 56 —
- 57 —
- 58 —
- 59 —
- 60 —



- 1 —
- 2 —
- 3 —
- 4 —
- 5 —
- 6 —
- 7 —
- 8 —
- 9 —
- 10 —
- 11 —
- 12 —
- 13 —
- 14 —
- 15 —
- 16 —
- 17 —
- 18 —
- 19 —
- 20 —
- 21 —
- 22 —
- 23 —
- 24 —
- 25 —
- 26 —
- 27 —
- 28 —
- 29 —
- 30 —
- 31 —
- 32 —
- 33 —
- 34 —
- 35 —
- 36 —
- 37 —
- 38 —



REPLACES	AUTOCAD	2309-1997	C 2
REVISION DATE	THE TRANE COMPANY	SCHEMATIC	
1-8-01	A DIVISION OF AMERICAN STANDARD INC.	RTAC	
DRAWN BY	REVISIONS TO THIS DRAWING WILL BE MADE BY THE TRANE COMPANY	LARGE AIR COOLED FAN COMPRESSOR(2A) WYE-DELTA THREE COMPRESSORS	
PBL	SIMILAR TO		
DATE			
8-1-00			

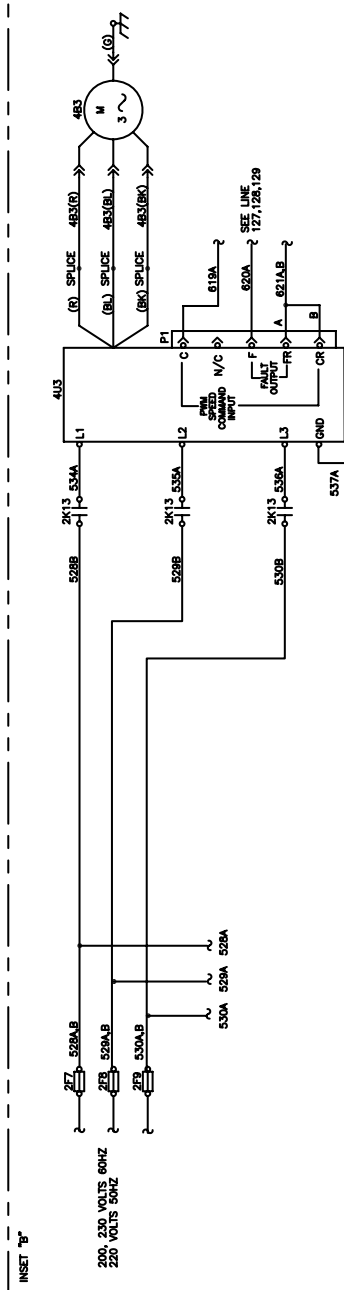
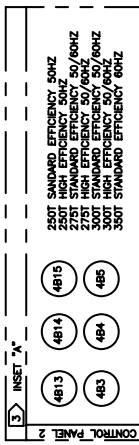
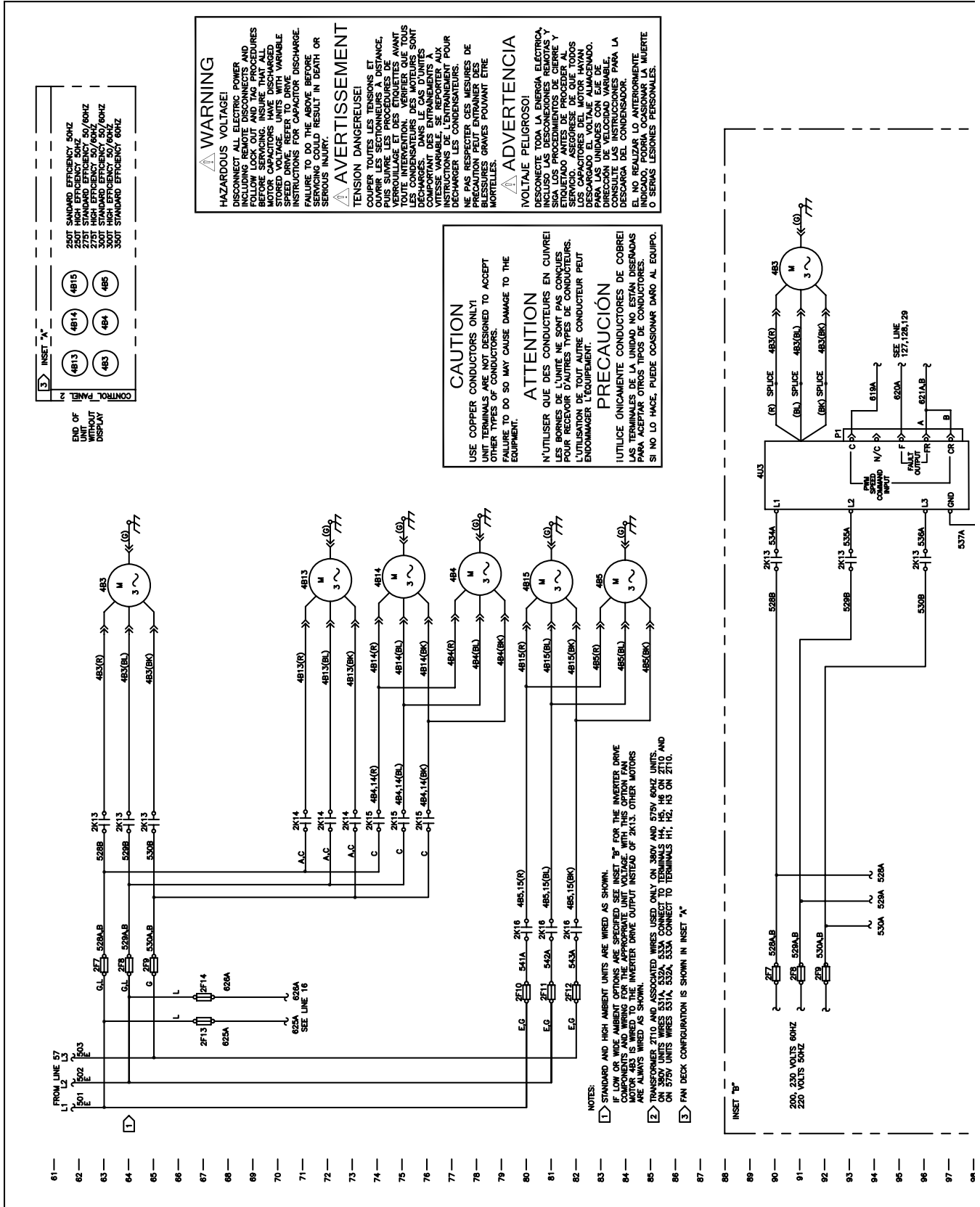
**WARNING** HAZARDOUS VOLTAGE!  
DISCONNECT ALL ELECTRIC POWER INCLUDING REMOTE DISCONNECTS AND FOLLOW LOCK OUT AND TAG PROCEDURES BEFORE SERVICING. CAPACITORS HAVE DISCHARGED STORED VOLTAGE. UNITS WITH CAPACITORS MUST BE DISCHARGED TO DRIVE INSTRUCTIONS FOR CAPACITOR DISCHARGE. FAILURE TO DO THE ABOVE BEFORE SERVICING COULD RESULT IN DEATH OR SERIOUS INJURY.

**AVERTISSEMENT** TENSION DANGEREUSE!  
COUPER TOUTES LES TENSIONS ET OUVRIER LES SECTIONNEURS A DISTANCE PLUS SUIVRE LES PROCEDURES DE VERROUILLAGE ET DES ETIQUETTES AVANT LE SERVICER. LES CONDENSATEURS DES MOTEURS SONT DECHARGES. DANS LE CAS D'UNITES A CONDENSATEURS, LES UNITES DOIVENT ETRE DECHARGES AVANT DE SERVICER. NE PAS RESPECTER CES MESURES DE SECURITE PEUT RESULTER EN MORTS OU BLESSURES GRAVES POUVANT ETRE MORTELLES.

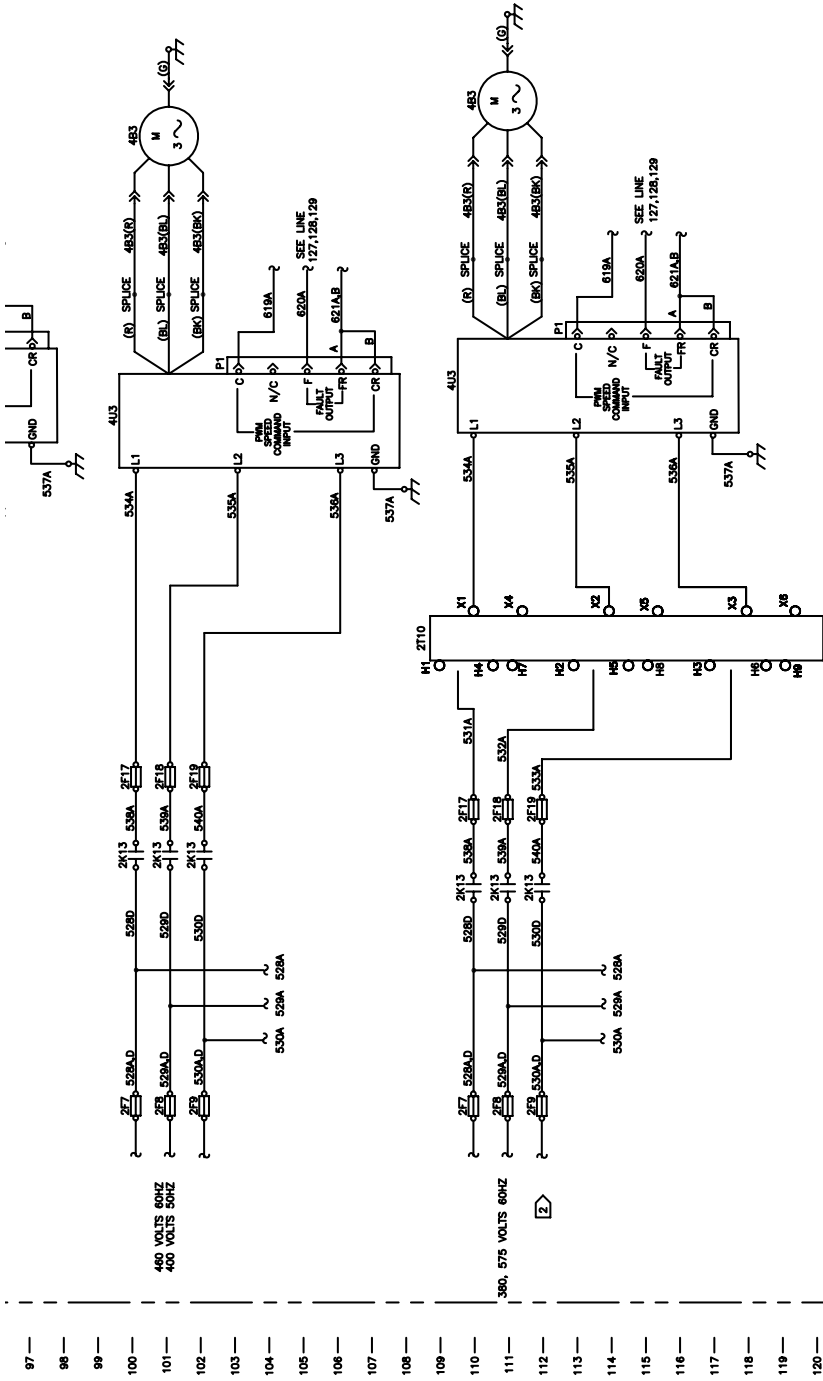
**ADVERTENCIA** VOLTAJE PELIGROSO!  
DESCONECTE TODA LA ENERGIA ELECTRICA INCLUIDO LAS DESCONEXIONES REMOTAS Y SIGA LOS PROCEDIMIENTOS DE CIERRE Y VERROUILLAJE ANTES DE SERVICIAR. LOS CONDENSADORES DEL MOTOR HAYAN DESCARGADO EL VOLTAJE ALMACENADO. EN EL CASO DE UNIDADES CON CONDENSADORES, LAS UNIDADES DEBEN SER DESCARGADAS ANTES DE SERVICIAR. CONSULTA LAS INSTRUCCIONES PARA LA DESCARGA DEL CONDENSADOR. EL NO REALIZAR LO ANTERIORMENTE PUEDE RESULTAR EN LA MUERTE O SERIAS LESIONES PERSONALES.

- NOTES:
1. WIRING FOR 480V OR 200V 60HZ UNIT SHOWN. SEE INSET "A" FOR CONTROL POWER TRANSFORMER WIRING FOR OTHER VOLTAGES.
  2. SINGLE OR DUAL SOURCE POWER OPTIONS ARE AVAILABLE. DUAL SOURCE POWER IS AVAILABLE ON ALL UNITS AND SINGLE SOURCE POWER IS AVAILABLE ONLY ON UNITS WITH SUPPLY VOLTAGES OF 400 VOLTS OR HIGHER. THIS DRAWING SHOWS THE DUAL SOURCE POWER OPTION FOR CIRCUIT 2. WHEN USING THE SINGLE SOURCE POWER OPTION, REFER TO DRAWING 2309-2219 FOR DETAILS OF THE SINGLE SOURCE POWER OPTION.

36 —  
37 —  
38 —  
39 —  
40 —  
41 —  
42 —  
43 —  
44 —  
45 —  
46 —  
47 —  
48 —  
49 —  
50 —  
51 —  
52 —  
53 —  
54 —  
55 —  
56 —  
57 —  
58 —  
59 —  
60 —



REPLACES	AUTOCAD	2309-1999	REV
REVISION DATE	THE TRANE COMPANY A DIVISION OF AMERICAN STANDARD INC.		C
2-20-01			
DRAWN BY	DESIGNED & CHECKED BY		
TR	RTAC		
DATE	8-7-00		
	SIMILAR TO		
		SCHMATIC	
		RTAC	
		LARGE AIR COOLED	
		FANS	
		PANEL 2	
		THREE COMPRESSORS	



**HAZARDOUS VOLTAGE!**

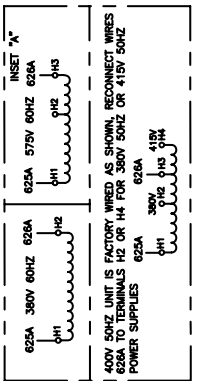
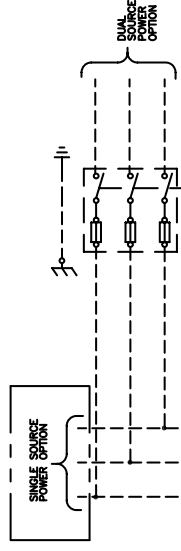
DISCONNECT ALL ELECTRIC POWER FROM THE UNIT BEFORE SERVICING AND FOLLOW LOCK OUT AND TAG PROCEDURES BEFORE SERVICING. INSURE THAT ALL MOTOR WINDINGS ARE COMPLETELY DISCHARGED. ALWAYS USE THE CORRECT WIRE GAUGE AND WIRE TYPE FOR THE APPLICATION. ALWAYS USE THE CORRECT WIRE COLOR AND WIRE SIZE. ALWAYS USE THE CORRECT WIRE GAUGE AND WIRE TYPE FOR THE APPLICATION. ALWAYS USE THE CORRECT WIRE COLOR AND WIRE SIZE. ALWAYS USE THE CORRECT WIRE GAUGE AND WIRE TYPE FOR THE APPLICATION. ALWAYS USE THE CORRECT WIRE COLOR AND WIRE SIZE.

**WARNING**

TENSION DANGEREUSE! COUPER TOUTES LES TENSIONS ET SUIVRE LES PROCEDURES DE VERROUILLAGE ET DES ETIQUETTES AVANT TOUTE INTERVENTION. VERIFIER QUE TOUTES LES UNITES SONT COMPLETEMENT DECHARGES. TOUJOURS UTILISER LE BON CALIBRE DE FIL ET LE BON TYPE DE FIL POUR L'APPLICATION. TOUJOURS UTILISER LE BON CALIBRE DE FIL ET LE BON TYPE DE FIL POUR L'APPLICATION. TOUJOURS UTILISER LE BON CALIBRE DE FIL ET LE BON TYPE DE FIL POUR L'APPLICATION. TOUJOURS UTILISER LE BON CALIBRE DE FIL ET LE BON TYPE DE FIL POUR L'APPLICATION.

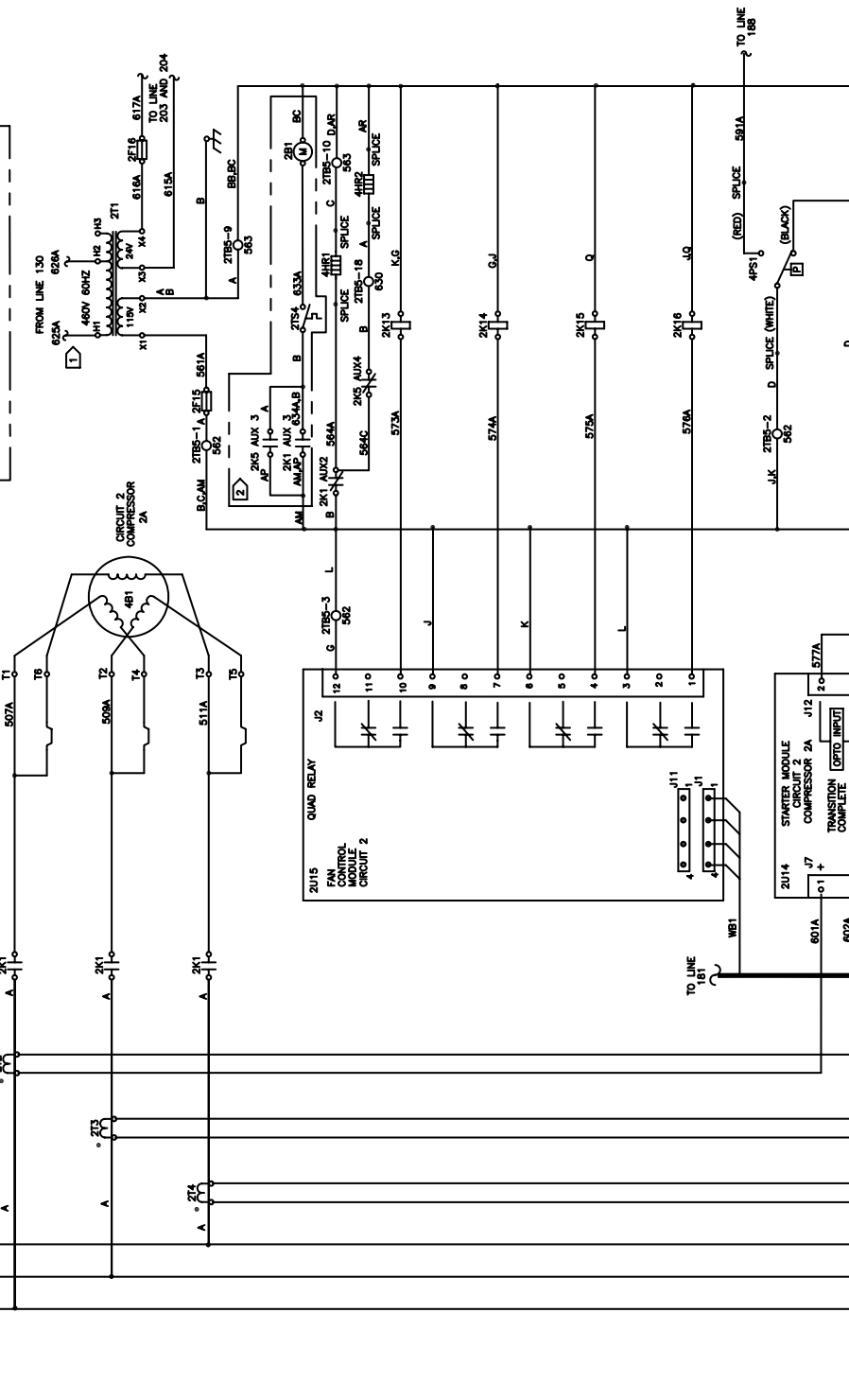
**AVERTISSEMENT**

VOLTAJE PELIGROSO! DESCONECTE TODA LA ENERGIA ELECTRICA DE LA UNIDAD ANTES DE REALIZAR CUALQUIER SERVICIO. SIGA LOS PROCEDIMIENTOS DE CERRAJE Y ETIQUETADO ANTES DE PROCEDER AL SERVICIO. ASEGURESE DE QUE TODOS LOS UNIDADES SEAN COMPLETAMENTE DESCARGADO EL VOLTAJE ALMACENADO. SIEMPRE UTILICE EL CORRECTO GAUGE Y TIPO DE CABLE PARA LA DIRECCION DE VELOCIDAD VARIABLE, SIEMPRE UTILICE EL CORRECTO GAUGE Y TIPO DE CABLE PARA LA DIRECCION DE VELOCIDAD VARIABLE. SIEMPRE UTILICE EL CORRECTO GAUGE Y TIPO DE CABLE PARA LA DIRECCION DE VELOCIDAD VARIABLE. SIEMPRE UTILICE EL CORRECTO GAUGE Y TIPO DE CABLE PARA LA DIRECCION DE VELOCIDAD VARIABLE.

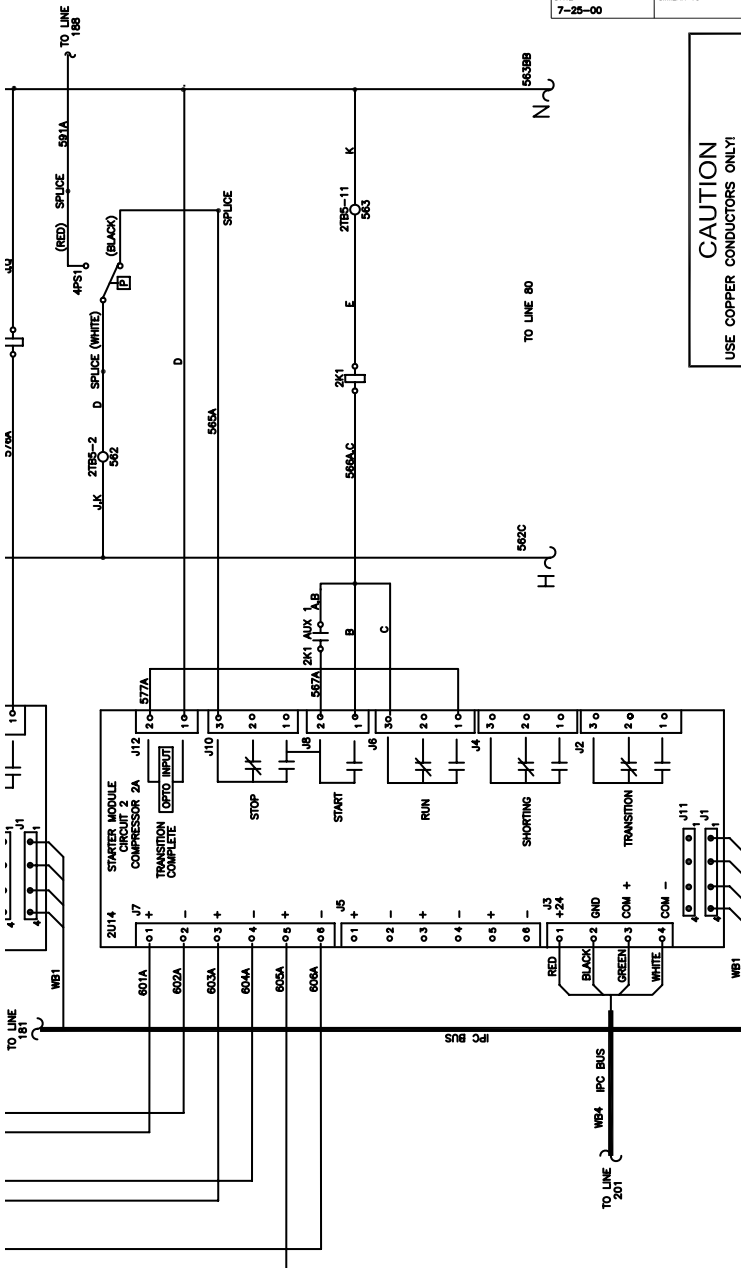


400V 50HZ UNIT IS FACTORY WIRED AS SHOWN. RECONNECT WIRES 622A TO TERMINALS H2 OR H4 FOR 380V 50HZ OR 415V 50HZ POWER SUPPLIES

- 1 —
- 2 —
- 3 —
- 4 —
- 5 —
- 6 —
- 7 —
- 8 —
- 9 —
- 10 —
- 11 —
- 12 —
- 13 —
- 14 —
- 15 —
- 16 —
- 17 —
- 18 —
- 19 —
- 20 —
- 21 —
- 22 —
- 23 —
- 24 —
- 25 —
- 26 —
- 27 —
- 28 —
- 29 —
- 30 —
- 31 —
- 32 —
- 33 —
- 34 —
- 35 —
- 36 —
- 37 —



35 —  
36 —  
37 —  
38 —  
39 —  
40 —  
41 —  
42 —  
43 —  
44 —  
45 —  
46 —  
47 —  
48 —  
49 —  
50 —  
51 —  
52 —  
53 —  
54 —  
55 —  
56 —  
57 —  
58 —  
59 —  
60 —



NOTES:  
 1 WIRING FOR 480V 60HZ UNIT SHOWN. SEE INSET "A" FOR CONTROL POWER TRANSFORMER WIRING FOR OTHER VOLTAGES.  
 2 PANEL VENTILATION FAN IS PROVIDED.  
 3 DUAL SOURCE POWER OPTION IS AVAILABLE FOR ALL UNITS AND SINGLE SOURCE POWER IS AVAILABLE ONLY ON UNITS WITH SUPPLY VOLTAGES OF 400 VOLTS OR HIGHER. THIS DRAWING SHOWS THE DUAL SOURCE POWER OPTION FOR CIRCUIT 2. WHEN SINGLE SOURCE POWER IS PROVIDED AN ADDITIONAL PANEL AND WIRING DIAGRAM POWER OPTION. REFER TO DRAWING 2309-2219 FOR DETAILS OF THE SINGLE SOURCE POWER OPTION.

REPLACES	AUTOCAD	2309-2201	REV
REVISION DATE	THIS TRAINER COMPANY		C
DESIGNED BY	A DIVISION OF AMERICAN STANDARD INC.	SCHMATIC	
DATE	7-25-00	RTAC	
		LARGE AIR COOLED COMPRESSOR(2A) X-L START	
		FOUR COMPRESSORS	

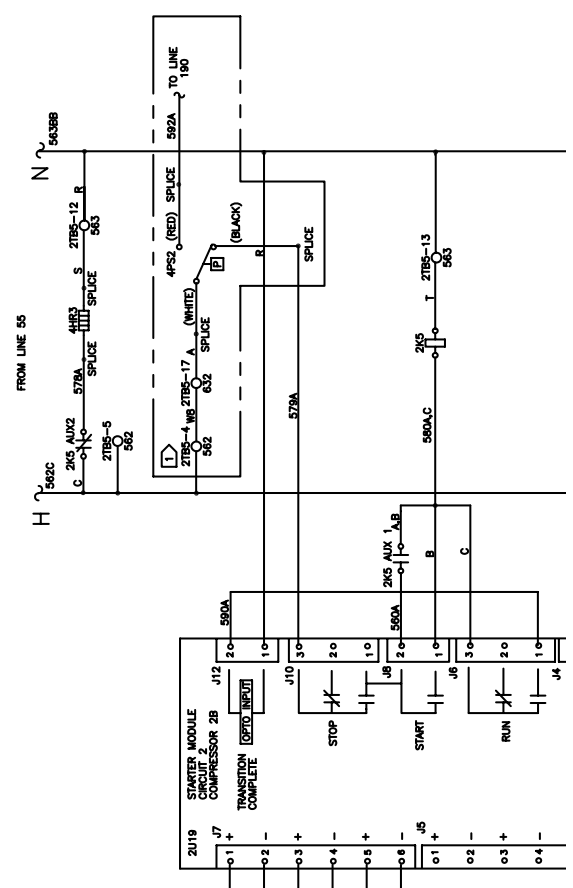
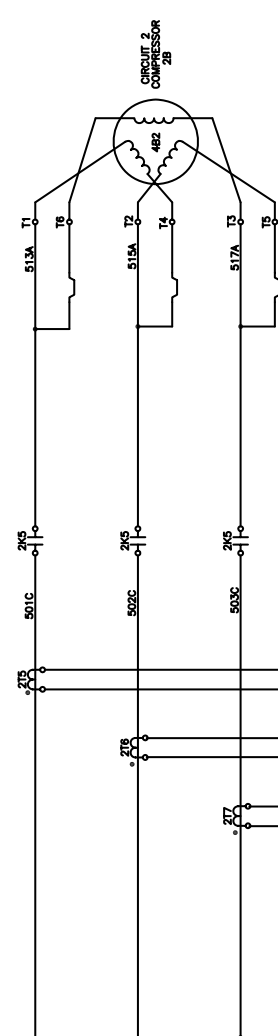
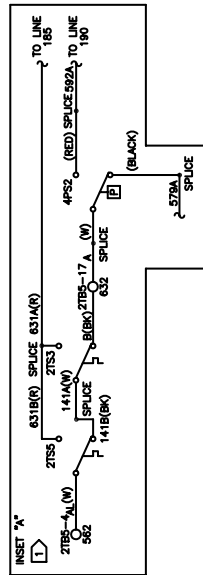
**CAUTION**  
 USE COPPER CONDUCTORS ONLY!  
 UNIT TERMINALS ARE NOT DESIGNED TO ACCEPT OTHER TYPES OF CONDUCTORS.  
 FAILURE TO DO SO MAY CAUSE DAMAGE TO THE EQUIPMENT.

**ATTENTION**  
 N'UTILISER QUE DES CONDUCTEURS EN CUIVRE!  
 LES BORNES DE L'UNITE NE SONT PAS CONÇUES POUR RECEVOIR D'AUTRES TYPES DE CONDUCTEURS.  
 L'USAGE D'UN AUTRE TYPE DE CONDUCTEUR PEUT ENDOMMAGER L'EQUIPEMENT.

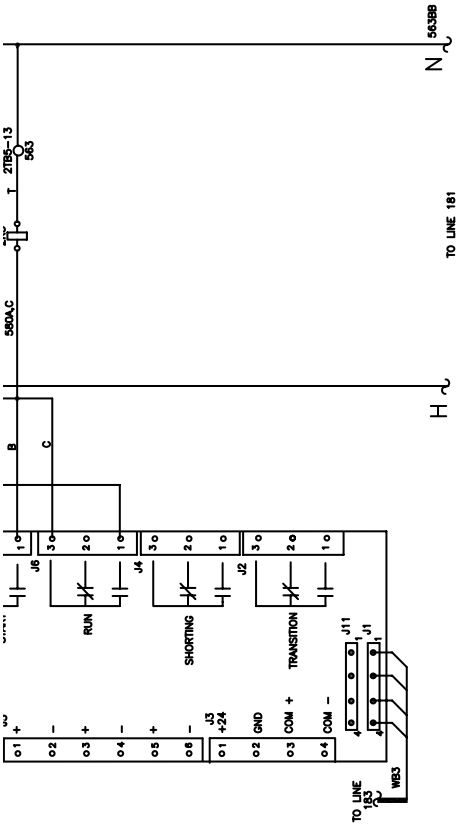
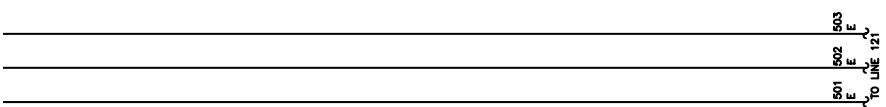
**PRECAUCIÓN**  
 ¡UTILICE ÚNICAMENTE CONDUCTORES DE COBRE!  
 LAS TERMINALES DE LA UNIDAD NO ESTÁN DISEÑADAS PARA ACEPTAR OTROS TIPOS DE CONDUCTORES.  
 SI NO LO HACE, PUEDE OCASIONAR DAÑO AL EQUIPO.

FROM LINE 57  
 L1 L3  
 501 502 503  
 504 505

61—  
 62—  
 63—  
 64—  
 65—  
 66—  
 67—  
 68—  
 69—  
 70—  
 71—  
 72—  
 73—  
 74—  
 75—  
 76—  
 77—  
 78—  
 79—  
 80—  
 81—  
 82—  
 83—  
 84—  
 85—  
 86—  
 87—  
 88—  
 89—  
 90—  
 91—  
 92—  
 93—  
 94—  
 95—  
 96—  
 97—



93 —  
94 —  
95 —  
96 —  
97 —  
98 —  
99 —  
100 —  
101 —  
102 —  
103 —  
104 —  
105 —  
106 —  
107 —  
108 —  
109 —  
110 —  
111 —  
112 —  
113 —  
114 —  
115 —  
116 —  
117 —  
118 —  
119 —  
120 —



NOTES:  
 1 UNITS WITHOUT THE CONTROL PANEL VENTILATION FAN ARE WIRED AS SHOWN.  
 SEE INSET 'X' FOR WIRING WHEN THE VENTILATION FAN IS PROVIDED.

REPLACES	AUTOCAD	2309-2202	REV C
REVISION DATE	THIS TRANE COMPANY	SCHEMATIC	
1-8-03	AMERICA'S TRANE DIVISION	RTAC	
DRAWN BY	TRANE TRANE COMPANY INC.	LARGE AIR COOLED COMPRESSOR(2S) X-L START PANEL	
PBL	TRANE TRANE COMPANY INC.	FOUR COMPRESSORS	
DATE	7-26-00		

**HAZARDOUS VOLTAGE!**  
 DISCONNECT ALL ELECTRIC POWER TO THE UNIT BEFORE SERVICING AND FOLLOW LOCK OUT AND TAG PROCEDURES BEFORE SERVICING. FAILURE TO FOLLOW THESE PROCEDURES MAY RESULT IN DEATH OR SERIOUS INJURY. REFER TO THE SERVICE MANUAL FOR VARIABLE SPEED DRIVE. REFER TO THE SERVICE MANUAL FOR CAPACITOR DISCHARGE PROCEDURES FOR FAILURE TO DO THE ABOVE BEFORE SERVICING COULD RESULT IN DEATH OR SERIOUS INJURY.

**AVERTISSEMENT**  
 TENSION DANGEREUSE!  
 COUPER TOUTES LES TENSIONS ET SUIVRE LES PROCEDURES DE VERROUILLAGE ET DES ETIQUETTES AVANT DE PROCEDER AU SERVICE. NE PAS OUBLIER DE SUIVRE LES PROCEDURES DE VERROUILLAGE ET DES ETIQUETTES AVANT DE PROCEDER AU SERVICE. LA NECESSITE DE SUIVRE LES PROCEDURES DE VERROUILLAGE ET DES ETIQUETTES AVANT DE PROCEDER AU SERVICE PEUT CAUSER LA MORT. VOUS POUVEZ ETRE BLESSE, MORTUellement, SI VOUS NE SUIVEZ PAS LES PROCEDURES DE VERROUILLAGE ET DES ETIQUETTES AVANT DE PROCEDER AU SERVICE. VOUS POUVEZ ETRE BLESSE, MORTUellement, SI VOUS NE SUIVEZ PAS LES PROCEDURES DE VERROUILLAGE ET DES ETIQUETTES AVANT DE PROCEDER AU SERVICE. VOUS POUVEZ ETRE BLESSE, MORTUellement, SI VOUS NE SUIVEZ PAS LES PROCEDURES DE VERROUILLAGE ET DES ETIQUETTES AVANT DE PROCEDER AU SERVICE.

**ADVERTENCIA**  
 VOLTAJE PELIGROSO!  
 DESCONECTE TODA LA ENERGIA ELECTRICA DE LA UNIDAD ANTES DE SERVICIAR Y SIGA LOS PROCEDIMIENTOS DE CIERRE Y ETIQUETADO ANTES DE PROCEDER AL SERVICIO. NO OLVIDE SIGUIR LOS PROCEDIMIENTOS DE CIERRE Y ETIQUETADO ANTES DE PROCEDER AL SERVICIO. USTED PUEDE SER HERIDO O MORTUAMENTE SI NO SIGUE LOS PROCEDIMIENTOS DE CIERRE Y ETIQUETADO ANTES DE PROCEDER AL SERVICIO. USTED PUEDE SER HERIDO O MORTUAMENTE SI NO SIGUE LOS PROCEDIMIENTOS DE CIERRE Y ETIQUETADO ANTES DE PROCEDER AL SERVICIO. USTED PUEDE SER HERIDO O MORTUAMENTE SI NO SIGUE LOS PROCEDIMIENTOS DE CIERRE Y ETIQUETADO ANTES DE PROCEDER AL SERVICIO.

**CAUTION**  
 USE COPPER CONDUCTORS ONLY!  
 UNIT TERMINALS ARE NOT DESIGNED TO ACCEPT OTHER TYPES OF CONDUCTORS.  
 FAILURE TO DO SO MAY CAUSE DAMAGE TO THE EQUIPMENT.

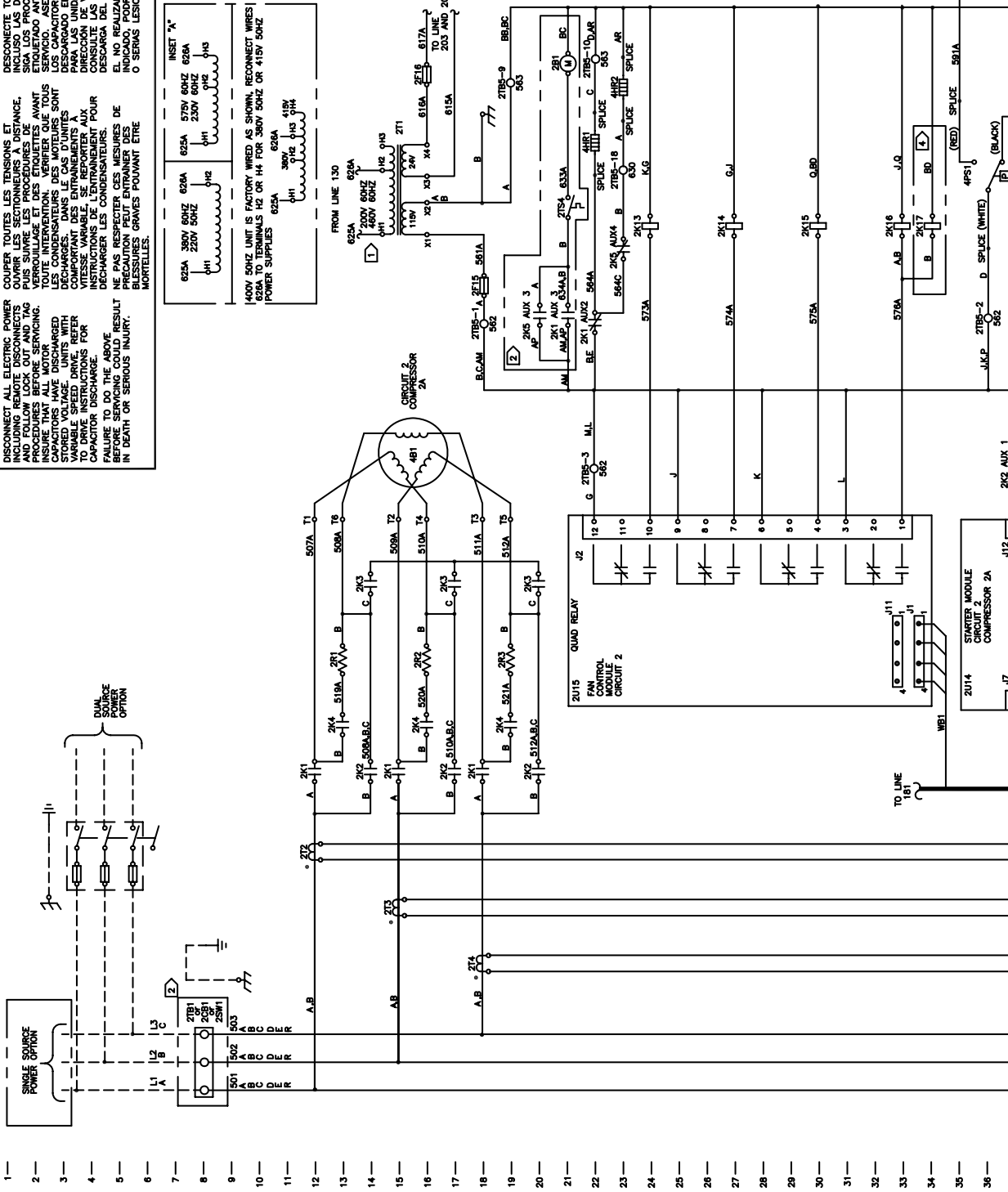
**PRECAUCIÓN**  
 N'UTILISER QUE DES CONDUCTEURS EN CUIVRE!  
 LES BORNES DE L'UNITE NE SONT PAS CONÇUES POUR RECEVOIR D'AUTRES TYPES DE CONDUCTEURS.  
 L'UTILISATION DE TOUT AUTRE CONDUCTEUR PEUT ENDOMMAGER L'EQUIPEMENT.

**ATTENTION**  
 UTILISEZ UNICAMENTE CONDUCTORES DE COBRE!  
 LAS TERMINALES DE LA UNIDAD NO ESTAN DISEÑADAS PARA ACEPTAR OTROS TIPOS DE CONDUCTORES.  
 SI NO LO HACE, PUEDE OCASIONAR DAÑO AL EQUIPO.

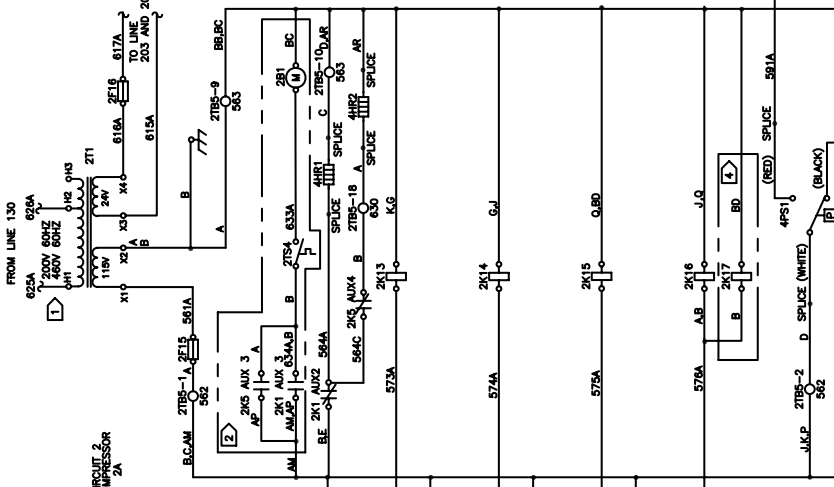
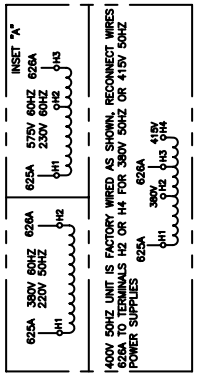
**HAZARDOUS VOLTAGE!**  
DISCONNECT ALL ELECTRIC POWER INCLUDING REMOTE DISCONNECTS AND FOLLOW LOCK OUT AND TAG PROCEDURES BEFORE SERVICING. INSURE THAT ALL MOTOR CAPACITORS HAVE DISCHARGED. STORED VOLTAGE UNITS WITH CAPACITORS MUST BE KEPT TO DRIVE INSTRUCTIONS FOR CAPACITOR DISCHARGE. FAILURE TO DO THE ABOVE BEFORE SERVICING COULD RESULT IN DEATH OR SERIOUS INJURY.

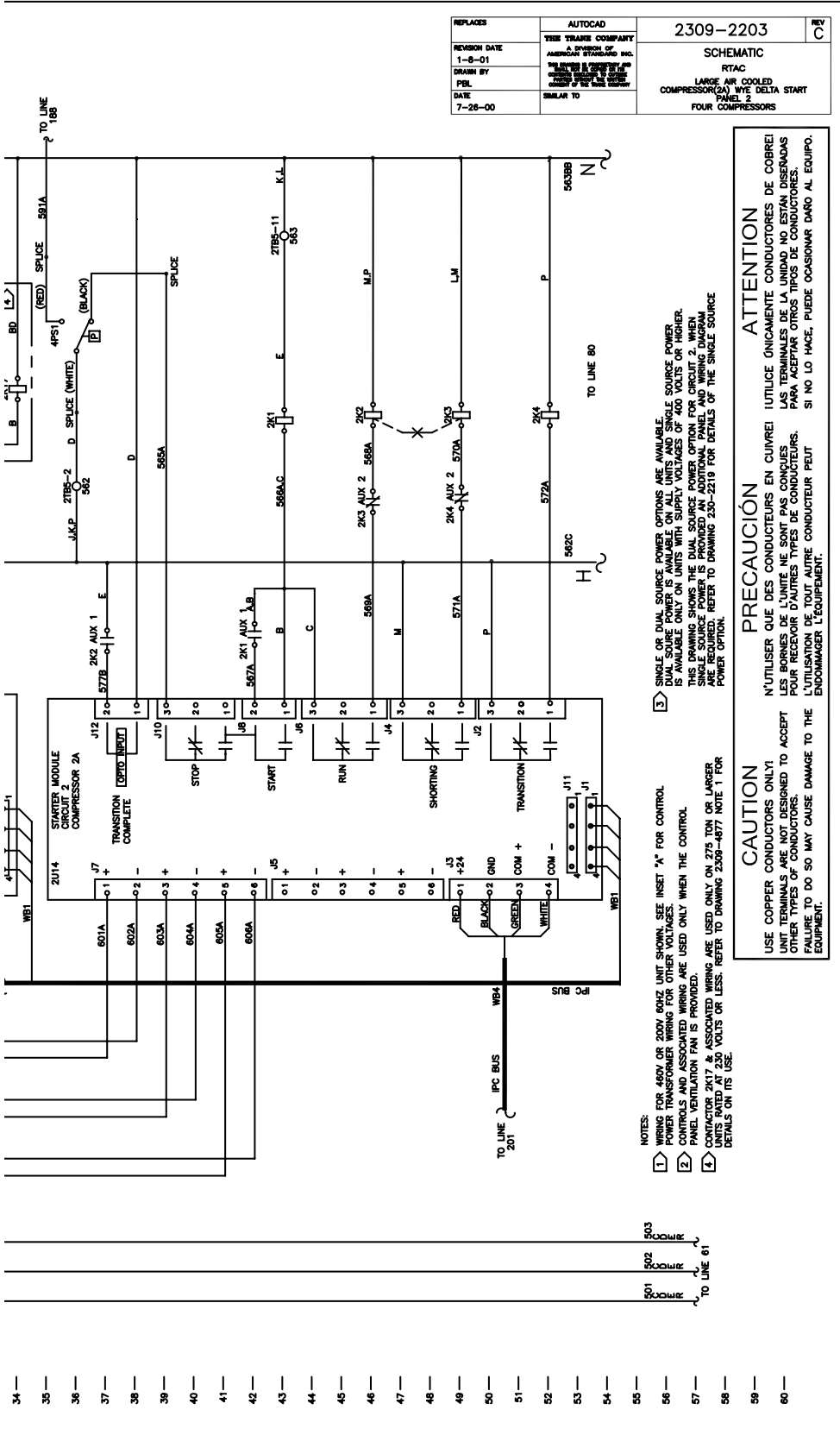
**AVERTISSEMENT**  
TENSION DANGEREUSE!  
COUPER TOUTES LES TENSIONS ET OUVRIRE LES SECTIONNEURS A DISTANCE. PLUS SUIVRE LES PROCEDURES DE VERIFICATION. ASSUREZ-VOUS QUE TOUS LES CONDENSATEURS DES MOTEURS SONT DECHARGES. DANS LE CAS D'UNITES A TENSION ALIENEES, IL FAUT SUIVRE LES INSTRUCTIONS POUR LE DECHARGEMENT DES CONDENSATEURS. NE PAS RESPECTER CES MESURES DE SECURITE PEUT CAUSER LA MORT OU DES BLESSURES GRAVES POUVANT ETRE MORTELLES.

**ADVERTENCIA**  
VOLTAJE PELIGROSO!  
DESCONECTE TODA LA ENERGIA ELECTRICA INCLUIDO LAS DESCONEXIONES REMOTAS Y SIGA LOS PROCEDIMIENTOS DE CIERRE Y VERIFICACION ANTES DE SERVICIO. ASEGURESE DE QUE TODOS LOS CAPACITORES DEL MOTOR HAYAN DESCARGADO EL VOLTAJE ALIENENADO. EN EL CASO DE UNIDADES CON TENSION VARIABLE, SIGA LAS INSTRUCCIONES PARA LA DESCARGA DEL CONDENSADOR. EL NO REALIZAR LO ANTERIORMENTE MENCIONADO PUEDE RESULTAR EN MUERTE O SERIAS LESIONES PERSONALES.



- 1 —
- 2 —
- 3 —
- 4 —
- 5 —
- 6 —
- 7 —
- 8 —
- 9 —
- 10 —
- 11 —
- 12 —
- 13 —
- 14 —
- 15 —
- 16 —
- 17 —
- 18 —
- 19 —
- 20 —
- 21 —
- 22 —
- 23 —
- 24 —
- 25 —
- 26 —
- 27 —
- 28 —
- 29 —
- 30 —
- 31 —
- 32 —
- 33 —
- 34 —
- 35 —
- 36 —





REPLACES	AUTOCAD	2309-2203	REV
REVISION DATE	TECH TRAINER COMPANY		C
1-8-01	AMERICAN SCHOOL OF BUSINESS TRAINING INC.	SCHEMATIC	
DRAWN BY	THE TRAINER COMPANY	RTAC	
PBL	AMERICAN SCHOOL OF BUSINESS TRAINING INC.	LARGE AIR COOLED COMPRESSOR(2A) WYE DELTA START	
DATE	CONTROL PANEL	PANEL 2	
7-28-00	SIMILAR TO	FOUR COMPRESSORS	

- NOTES:
- 1) WIRING FOR 485V OR 208V LINE SUPPLY. SEE INSET "A" FOR CONTROL POWER TRANSFORMER WIRING FOR OTHER VOLTAGES.
  - 2) CONTROLS AND ASSOCIATED WIRING ARE USED ONLY WHEN THE CONTROL PANEL VENTILATION FAN IS PROVIDED.
  - 3) SINGLE OR DUAL SOURCE POWER OPTIONS ARE AVAILABLE. DUAL SOURCE POWER IS AVAILABLE ON ALL UNITS AND SINGLE SOURCE POWER IS AVAILABLE ONLY ON UNITS WITH SUPPLY VOLTAGES OF 400 VOLTS OR HIGHER. THIS DRAWING SHOWS THE DUAL SOURCE POWER OPTION FOR CIRCUIT 2. WHEN THE SINGLE SOURCE POWER OPTION IS USED, THE WIRING AND PANEL WIRING ARE REQUIRED. REFER TO DRAWING 230-2210 FOR DETAILS OF THE SINGLE SOURCE POWER OPTION.
  - 4) CONTACTOR 2K17 & ASSOCIATED WIRING ARE USED ONLY ON 275 TON OR LARGER UNITS RATED AT 230 VOLTS OR LESS. REFER TO DRAWING 2309-4877 NOTE 1 FOR DETAILS ON ITS USE.

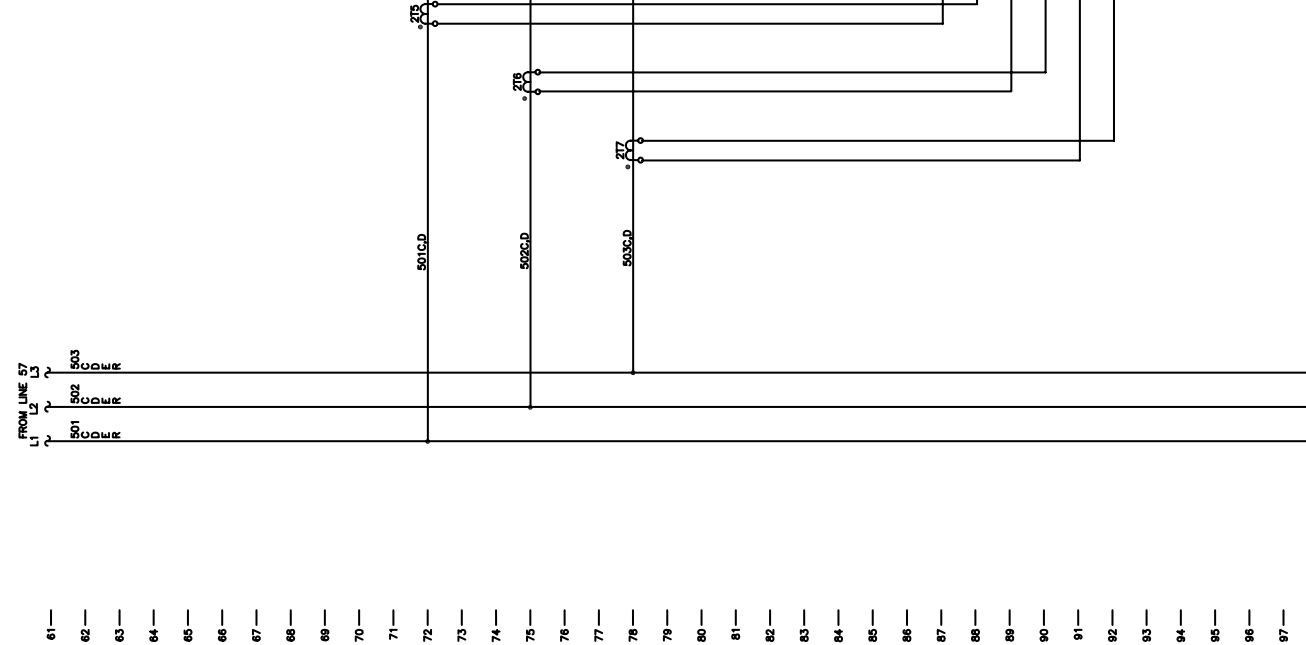
**CAUTION**  
 USE COPPER CONDUCTORS ONLY!  
 IF THE WIRING IS NOT DESIGNED TO ACCEPT OTHER TYPES OF CONDUCTORS, FAILURE TO DO SO MAY CAUSE DAMAGE TO THE EQUIPMENT.

**PRECAUCIÓN**  
 UTILIZAR ÚNICAMENTE CONDUCTORES DE COBRE!  
 SI NO LO HACE, PUEDE OCASIONAR DAÑO AL EQUIPO.

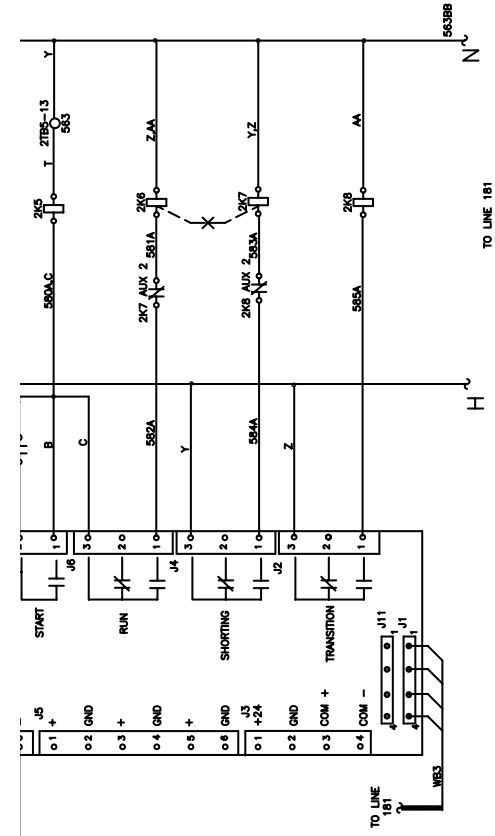
**CAUTION** USE COPPER CONDUCTORS ONLY!  
 UNIT TERMINALS ARE NOT DESIGNED TO ACCEPT OTHER TYPES OF CONDUCTORS.  
 FAILURE TO DO SO MAY CAUSE DAMAGE TO THE EQUIPMENT.

**PRECAUCIÓN** N'UTILISER QUE DES CONDUCTEURS EN CUIVRE!  
 LES BORNES DE L'UNITÉ NE SONT PAS CONÇUES POUR RECEVOIR D'AUTRES TYPES DE CONDUCTEURS.  
 L'ÉCLAUSEMENT À FAIRE AVEC UN CONDUCTEUR PEUT ENDOMMAGER L'ÉQUIPEMENT.

**ATTENTION** UTILISER UNICAMENTE CONDUCTORES DE COBRE!  
 LAS TERMINALES DE LA UNIDAD NO ESTÁN DISEÑADAS PARA ACEPTAR OTROS TIPOS DE CONDUCTORES.  
 SI NO LO HACE, PUEDE CAUSAR DAÑO AL EQUIPO.



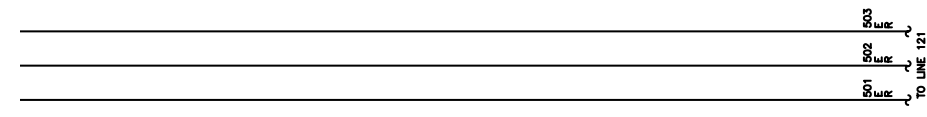
93 —  
94 —  
95 —  
96 —  
97 —  
98 —  
99 —  
100 —  
101 —  
102 —  
103 —  
104 —  
105 —  
106 —  
107 —  
108 —  
109 —  
110 —  
111 —  
112 —  
113 —  
114 —  
115 —  
116 —  
117 —  
118 —  
119 —  
120 —

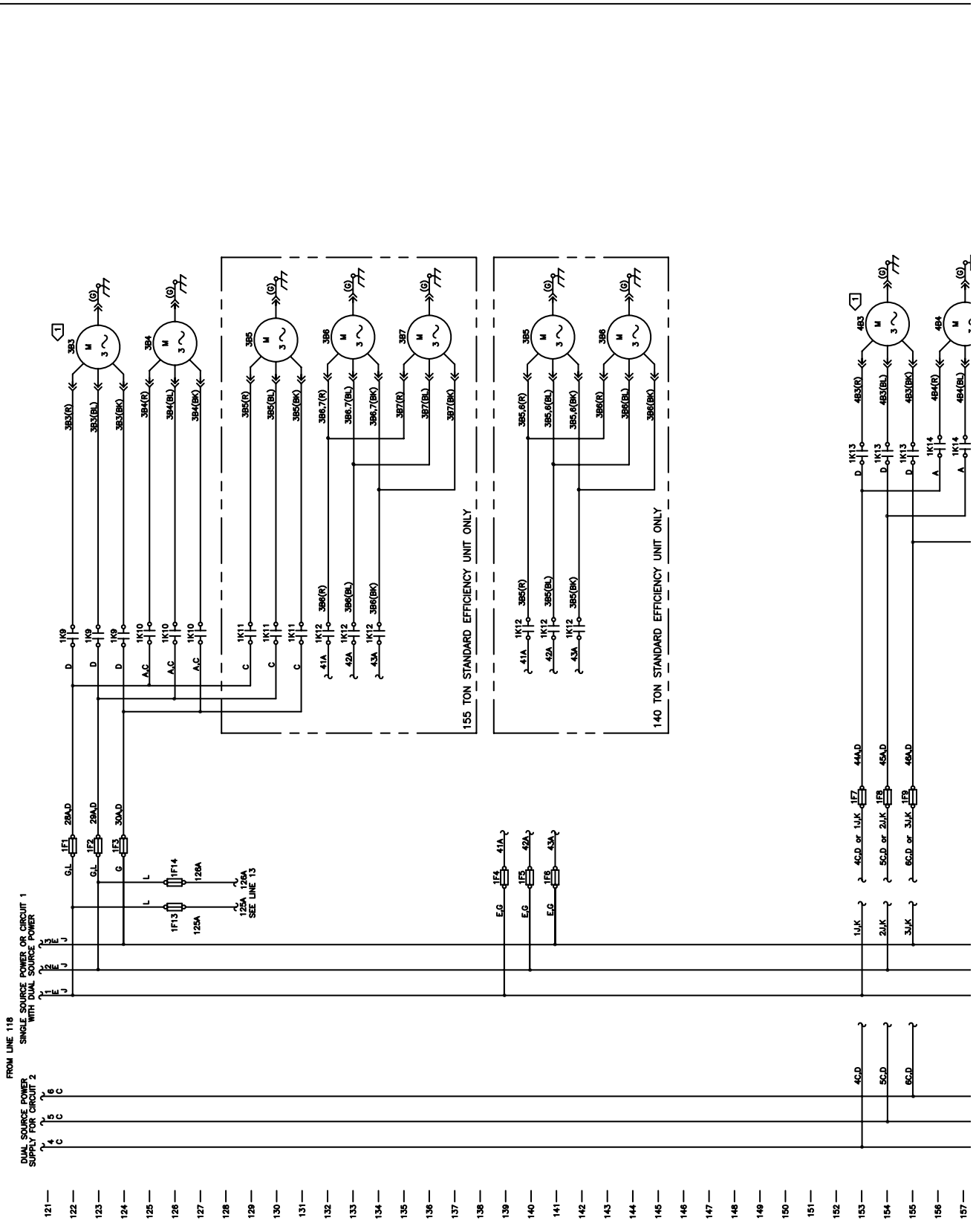


NOTES:  
 1 UNITS WITHOUT THE CONTROL PANEL VENTILATION FAN ARE WIRED AS SHOWN.  
 SEE INSET "X" FOR WIRING WHEN THE VENTILATION FAN IS PROVIDED.

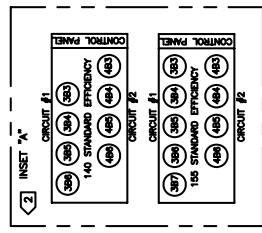
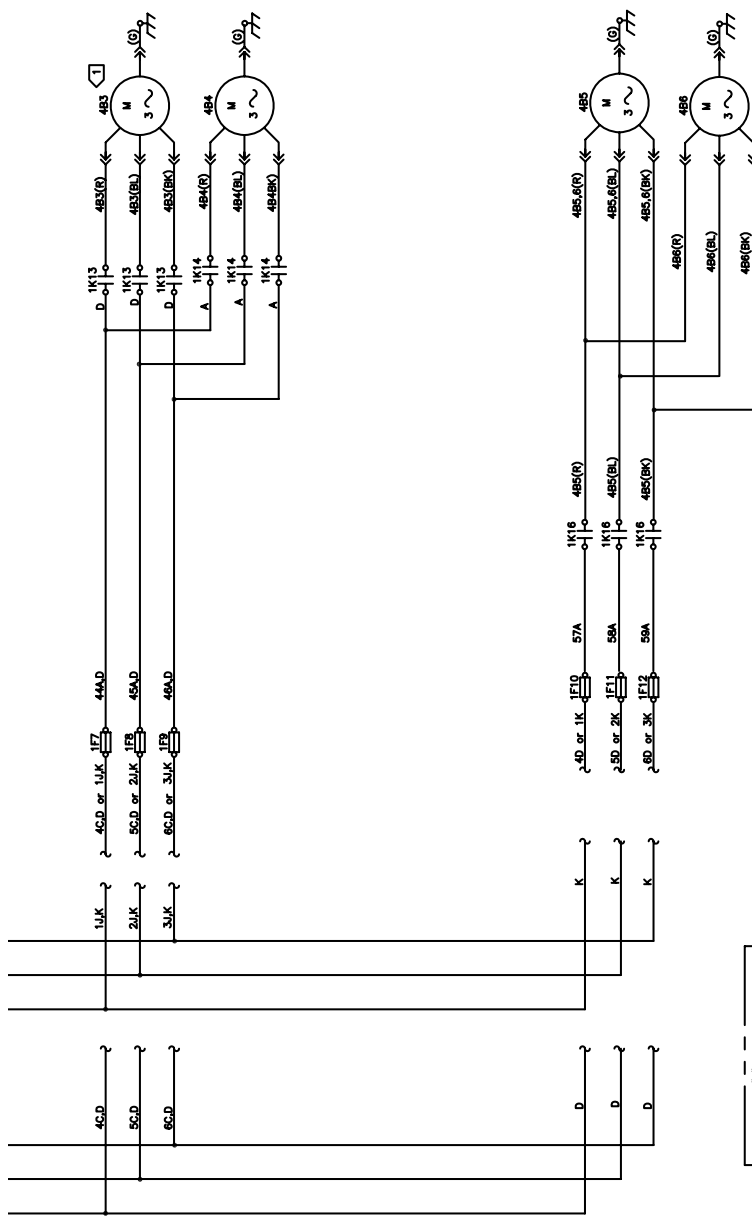
REPLACES	AUTOCAD	2309-2204	REV
REVISION DATE	TRIN TRAINER COMPANY		C
DRAWN BY	A SPECIALIST OF AMERICAN TRAINER INC.	SCHEMATIC	
PBL	MANUFACTURED BY	RTAC	
DATE	7-26-00	LAGAN AIR COOLED COMPRESSOR(2S) WYE-DELTA START PANEL 2	
	SIMILAR TO	FOUR COMPRESSORS	

<p><b>WARNING</b></p> <p>HAZARDOUS VOLTAGE!</p> <p>DISCONNECT ALL ELECTRIC POWER INCLUDING REMOTE DISCONNECTS BEFORE SERVICING. INSURE THAT ALL MOTOR WINDINGS ARE DISCHARGED. STORED VOLTAGE EXISTS WITH VARIABLE SPEED DRIVE. REFER TO DRIVE INSTRUCTIONS FOR CAPACITOR DISCHARGE PROCEDURE.</p> <p>NE PAS RESPECTER CES MESURES DE PRECAUTION PEUT ENTRAINER DES BLESSURES GRAVES POUVANT ETRE MORTELLES.</p>	<p><b>AVERTISSEMENT</b></p> <p>TENSION DANGEREUSE!</p> <p>COUPER TOUTES LES TENSIONS ET COURIR LES SECTIONNERS A DISTANCE, Y COMPRIS LES DISCONNECTS REMOTE, AVANT DE PROCEDER A TOUTE INTERVENTION. VERIFIER QUE TOUTES LES UNITES MOTEUR SONT DECHARGES. DES TENSIONS STOCKEES EXISTENT DANS LES UNITES A VITESSE VARIABLE. SE REPORTER AUX INSTRUCTIONS POUR LA DECHARGE DES CONDENSATEURS.</p> <p>NO REALIZAR LO ANTERIORMENTE INDICADO, PODRIA OCASIONAR LA MUERTE O SERIAS LESIONES PERSONALES.</p>	<p><b>ADVERTENCIA</b></p> <p>VOLTAJE PELIGROSO!</p> <p>DESCONECTE TODA LA ENERGIA ELECTRICA, INCLUIDO LAS DESCONEXIONES REMOTAS, Y CORRE LAS SECCIONES A DISTANCIA, Y ETIQUETADO ANTES DE PROCEDER AL SERVICIO. ASEGURESE DE QUE TODOS LOS UNIDADES MOTOR SON DESCARGADOS. DES TENSIONES ALMACENADAS EXISTEN EN LAS UNIDADES CON EJE DE DIRECCION DE VELOCIDAD VARIABLE. REFERIRSE A LAS INSTRUCCIONES PARA LA DESCARGA DEL CONDENSADOR.</p>
--	---	--





151 —  
 152 —  
 153 —  
 154 —  
 155 —  
 156 —  
 157 —  
 158 —  
 159 —  
 160 —  
 161 —  
 162 —  
 163 —  
 164 —  
 165 —  
 166 —  
 167 —  
 168 —  
 169 —  
 170 —  
 171 —  
 172 —  
 173 —  
 174 —  
 175 —  
 176 —  
 177 —  
 178 —  
 179 —  
 180 —



**NOTES:**  
 1 FANS 385 AND 483 ARE WIRED AS SHOWN FOR UNITS WITHOUT THE LOW AMBIENT OR WIDE AMBIENT TEMPERATURE OPTION. SEE DRG 2309-2243 FOR 385 AND 483 FAN WIRING WITH LOW AMBIENT OR WIDE AMBIENT TEMPERATURE OPTIONS. ALL OTHER FANS ARE WIRED AS SHOWN.  
 2 FAN DECK CONFIGURATIONS FOR VARIOUS TONNAGES AND EFFICIENCIES ARE SHOWN IN INSET "A".

**WARNING** ⚠️ **HAZARDOUS VOLTAGE!**  
 DISCONNECT ALL ELECTRIC POWER INCLUDING REMOTE DISCONNECTS PRIOR TO ANY SERVICING OPERATIONS. INSURE THAT ALL MOTORS ARE STORED VOLTAGE UNITS WITH VARIABLE SPEED DRIVE. REFER TO DRIVE INSTRUCTIONS FOR CAPACITOR DISCHARGE PROCEDURES.  
 ⚠️ **AVERTISSEMENT** ⚠️ **TENSION DANGEREUSE!**  
 DÉCONNECTEZ TOUTE L'ÉNERGIE ÉLECTRIQUE Y COMPRIS LES DÉCONNECTEURS À DISTANCE. ASSUREZ-VOUS QUE TOUS LES MOTEURS SONT DÉCHARGÉS. RÉFÉREZ-VOUS À LA LITTÉRATURE D'INSTRUCTIONS POUR LES UNITÉS À VITESSE VARIABLE. VOUS POUVEZ ÊTRE BLESSÉS GRAVES POUVANT ÊTRE MORTELLES.

**ADVERTENCIA** ⚠️ **VOLTAJE PELIGROSO!**  
 DESCONECTE TODA LA ENERGÍA ELÉCTRICA, INCLUIDOS LOS DESCONNECTORES REMOTOS Y ETIQUETADO ANTES DE PROCEDER AL SERVICIO. ASEGURESE DE QUE TODOS LOS MOTORES ESTÉN SIN CARGA. REFERIRSE A LA LITERATURA DE INSTRUCCIONES PARA LAS UNIDADES CON EJE DE DIRECCIÓN DE VELOCIDAD VARIABLE. PUEDE OCASIONAR LESIONES PERSONALES O SERIAS LESIONES PERSONALES. EL NO REALIZAR LO ANTERIORMENTE INDICADO, PODRÍA OCASIONAR LA MUERTE O SERIAS LESIONES PERSONALES.

**CAUTION**  
 USE COPPER CONDUCTORS ONLY!  
 UNIT TERMINALS ARE NOT DESIGNED TO ACCEPT OTHER TYPES OF CONDUCTORS.  
 FAILURE TO DO SO MAY CAUSE DAMAGE TO THE EQUIPMENT.

**ATTENTION**  
 N'UTILISER QUE DES CONDUCTEURS EN CUIVRE!  
 LES BORNES DE L'UNITÉ NE SONT PAS CONÇUES POUR RECEVOIR D'AUTRES TYPES DE CONDUCTEURS.  
 L'UTILISATION DE TOUT AUTRE CONDUCTEUR PEUT ENDOMMAGER L'ÉQUIPEMENT.

**PRECAUCIÓN**  
 ¡UTILICE ÚNICAMENTE CONDUCTORES DE COBRE!  
 LAS TERMINALES DE LA UNIDAD NO ESTÁN DISEÑADAS PARA RECIBIR OTROS TIPOS DE CONDUCTORES.  
 SI NO LO HACE, PUEDE OCASIONAR DAÑO AL EQUIPO.

REPLACES 2309-1955	AUTOCAD	2309-2241	C
REVISION DATE 03-09-01	THE TRANE COMPANY A DIVISION OF AMERICAN TRANE CO. INC. BIRMINGHAM & FORT WORTH, TEXAS DESIGN & DRAWING DEPARTMENT	SCHEMATIC	
DRAWN BY PBL	SIMILAR TO	RTAC MEDIUM AIR COOLED FANS 140 AND 150T STANDARD EFFICIENCY UNITS	
DATE 01-03-01			

**CAUTION**

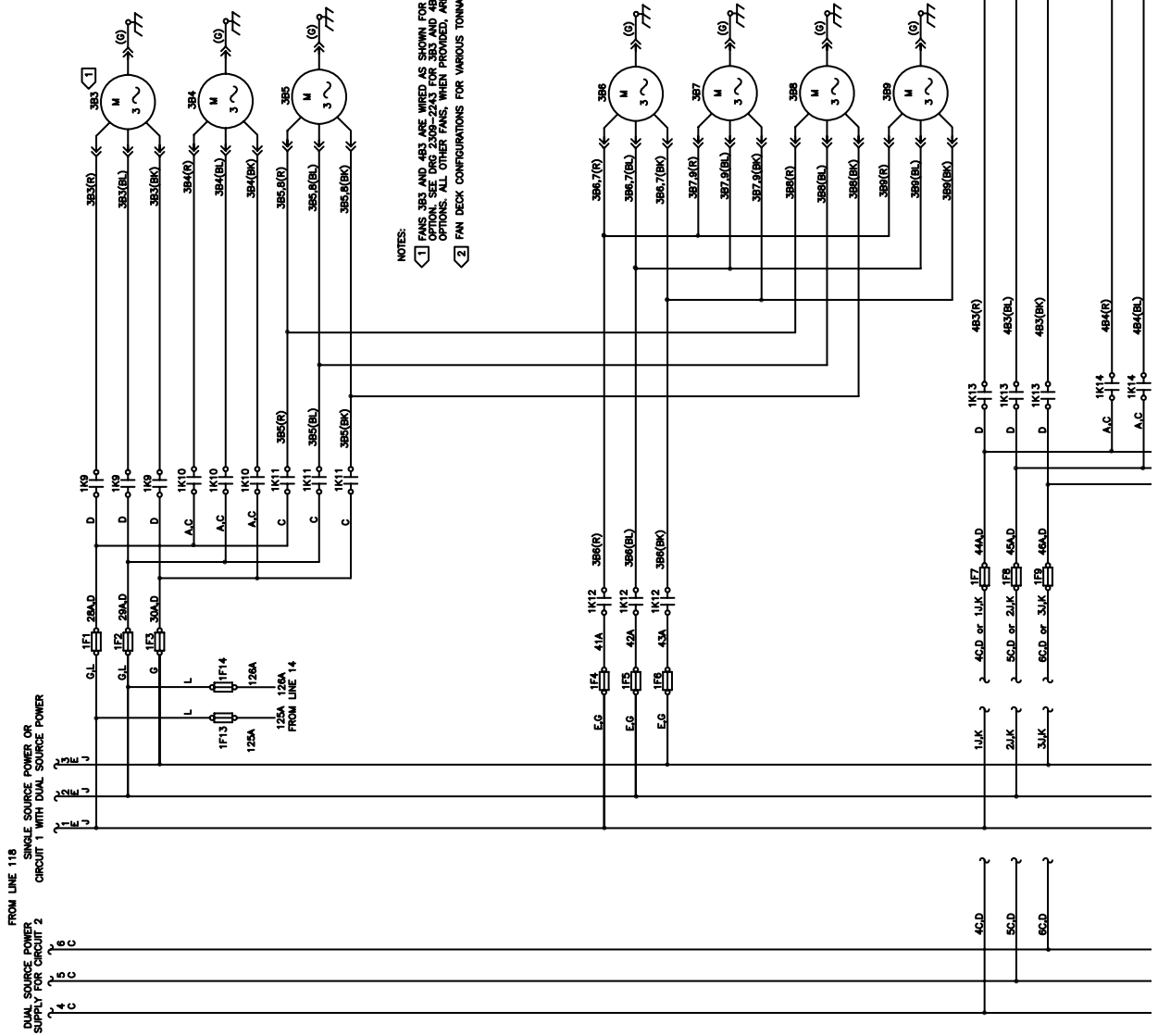
USE COPPER CONDUCTORS ONLY!  
UNIT TERMINALS ARE NOT DESIGNED TO ACCEPT OTHER TYPES OF CONDUCTORS.  
FAILURE TO DO SO MAY CAUSE DAMAGE TO THE EQUIPMENT.

**ATTENTION**

N'UTILISER QUE DES CONDUCTEURS EN CUIVRE!  
LES BORNES DE L'UNITÉ NE SONT PAS CONÇUES POUR RECEVOIR D'AUTRES TYPES DE CONDUCTEURS.  
L'UTILISATION DE TOUT AUTRE CONDUCTEUR PEUT ENDOMMAGER L'ÉQUIPEMENT.

**PRECAUCIÓN**

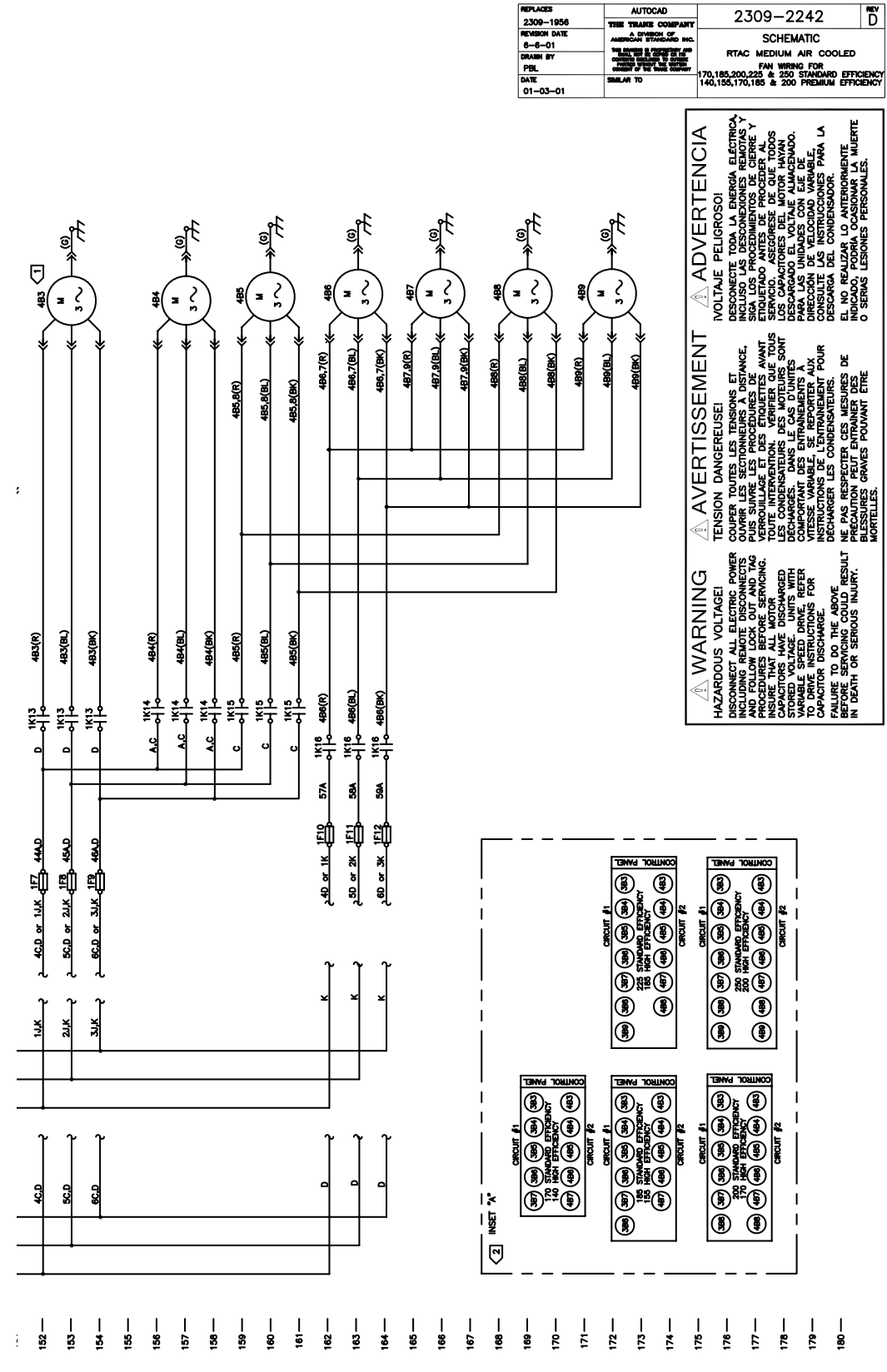
UTILICE ÚNICAMENTE CONDUCTORES DE COBRE!  
LAS TERMINALES DE LA UNIDAD NO ESTÁN DISEÑADAS PARA ACEPTAR OTROS TIPOS DE CONDUCTORES.  
SI NO LO HACE, PUEDE OCASIONAR DAÑO AL EQUIPO.



**NOTES:**

- 1 FANS 383 AND 483 ARE WIRED AS SHOWN FOR UNITS WITHOUT THE LOW AMBIENT OR WIDE AMBIENT TEMPERATURE OPTIONS. SEE DRAWING 22A FOR FANS 384 AND 484 WIRED AS SHOWN WITH LOW AMBIENT OR WIDE AMBIENT TEMPERATURE OPTIONS. ALL OTHER FANS, WHEN PROVIDED, ARE WIRED AS SHOWN. SEE FAN DECK ARRANGEMENT BELOW.
- 2 FAN DECK CONFIGURATIONS FOR VARIOUS TONNAGES AND EFFICIENCIES ARE SHOWN IN INSET "A".

- 121 —
- 122 —
- 123 —
- 124 —
- 125 —
- 126 —
- 127 —
- 128 —
- 129 —
- 130 —
- 131 —
- 132 —
- 133 —
- 134 —
- 135 —
- 136 —
- 137 —
- 138 —
- 139 —
- 140 —
- 141 —
- 142 —
- 143 —
- 144 —
- 145 —
- 146 —
- 147 —
- 148 —
- 149 —
- 150 —
- 151 —
- 152 —
- 153 —
- 154 —
- 155 —
- 156 —
- 157 —

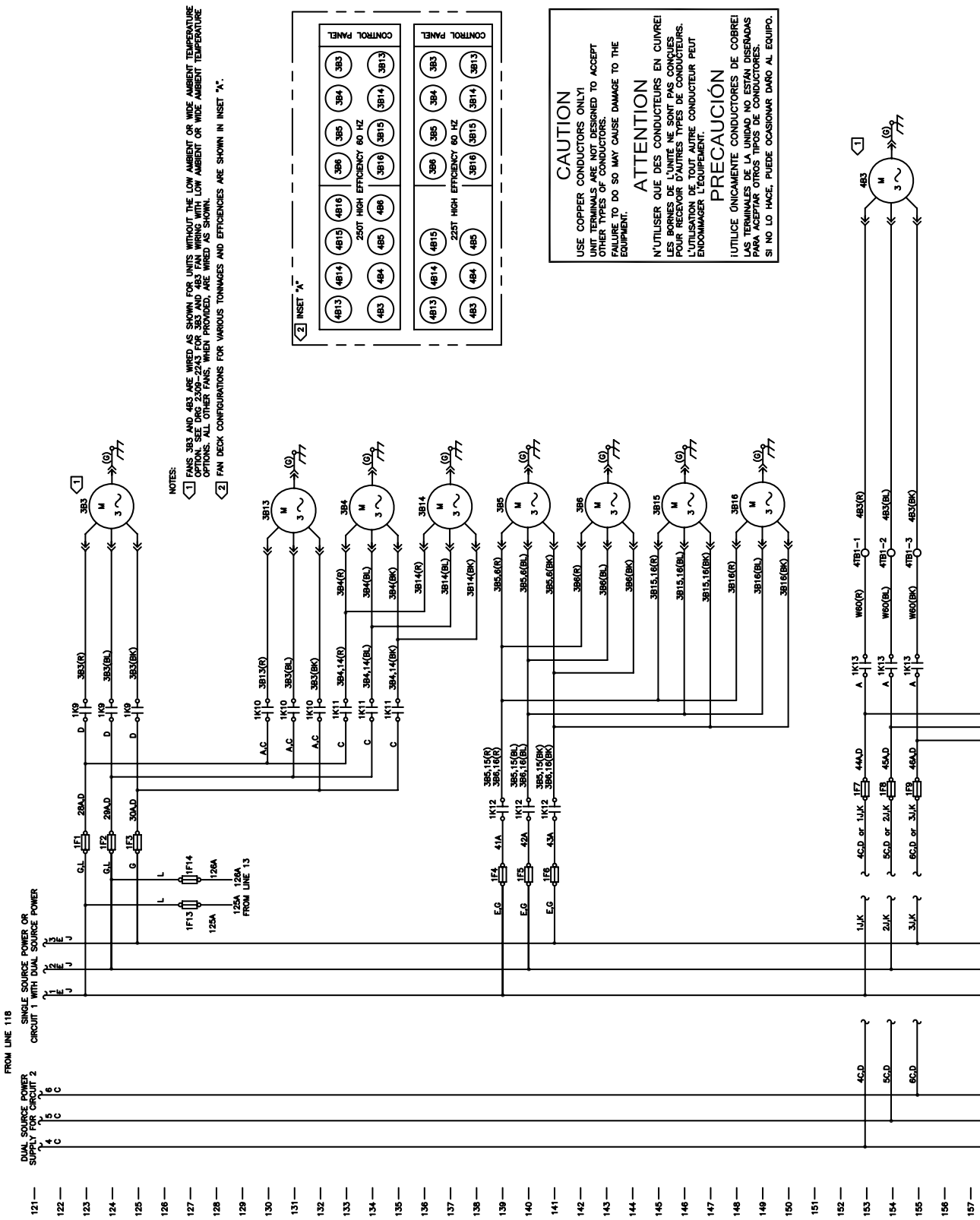


REPLACES 2309-1956	AUTOCAD THE TRANE COMPANY A DIVISION OF AMERSON CORPORATION 170, 185, 200, 225 & 250 STANDARD EFFICIENCY 140, 155, 170, 185 & 200 PREMIUM EFFICIENCY	2309-2242	REV D
REVISION DATE 8-6-01	DESIGNED BY PBL	SCHEMATIC RTAC MEDIUM AIR COOLED	
DATE 01-03-01	SIMILAR TO		

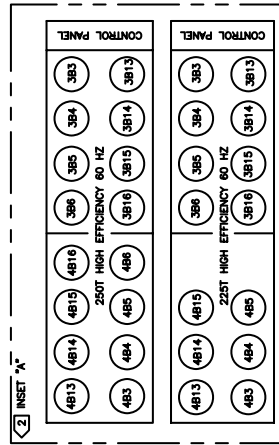
**⚠ WARNING**  
HAZARDOUS VOLTAGE!  
DISCONNECT ALL ELECTRIC POWER BEFORE SERVICING. FOLLOW LOCK OUT AND TAG PROCEDURES BEFORE SERVICING. INSURE THAT ALL MOTOR VOLTAGE IS DEPLETED. STORED VOLTAGE UNITS WITH VARIABLE SPEED DRIVE, REFER TO DRIVE INSTRUCTIONS FOR SERVICING. FAILURE TO DO THE ABOVE BEFORE SERVICING COULD RESULT IN DEATH OR SERIOUS INJURY.

**⚠ AVERTISSEMENT**  
TENSION DANGEREUSE!  
COUPER TOUTES LES TENSIONS ET SUIVRE LES PROCEDURES DE VERROUILLAGE ET DES ETIQUETTES AVANT TOUTE INTERVENTION. VERIFIER QUE TOUTES LES UNITES A VITESSE VARIABLE SONT DECHARGES DANS LE CAS D'UNITES COMPORTANT DES ENTRAÎNEMENTS A VITESSE VARIABLE. SE REFERER AUX INSTRUCTIONS POUR LE SERVICE DES UNITES A VITESSE VARIABLE. NE PAS RESPECTER CES MESURES DE PRECAUTION PEUT ENTRAÎNER DES BLESSURES GRAVES POUVANT ETRE MORTELLES.

**⚠ ADVERTENCIA**  
VOLTAJE PELIGROSO!  
DESCONECTE TODA LA ENERGIA ELECTRICA ANTES DE REALIZAR CUALQUIER SERVICIO. SIGA LOS PROCEDIMIENTOS DE CIERRE Y ETIQUETADO ANTES DE PROCEDER AL SERVICIO. ASEGURESE DE QUE TODOS LOS UNIDADES DE VELOCIDAD VARIABLE SON DESCARGADO EL VOLTAJE ALMACENADO. PARA LAS UNIDADES CON EJE DE DIRECCION DE VELOCIDAD VARIABLE, VERIFIQUE LAS INSTRUCCIONES PARA LA DESCARGA DEL CONDENSADOR. EL NO REALIZAR LO ANTERIORMENTE INDICADO, PODRIA OCASIONAR LA MUERTE O SERIAS LESIONES PERSONALES.



NOTES:  
 1 FANS 3B3 AND 4B3 ARE WIRED AS SHOWN FOR UNITS WITHOUT THE LOW AMBIENT OR WIDE AMBIENT TEMPERATURE OPTIONS. ALL OTHER FANS, WHEN PROVIDED, ARE WIRED AS SHOWN.  
 2 FAN BECK CONFIGURATIONS FOR VARIOUS TONNAGES AND EFFICIENCIES ARE SHOWN IN INSET "A".

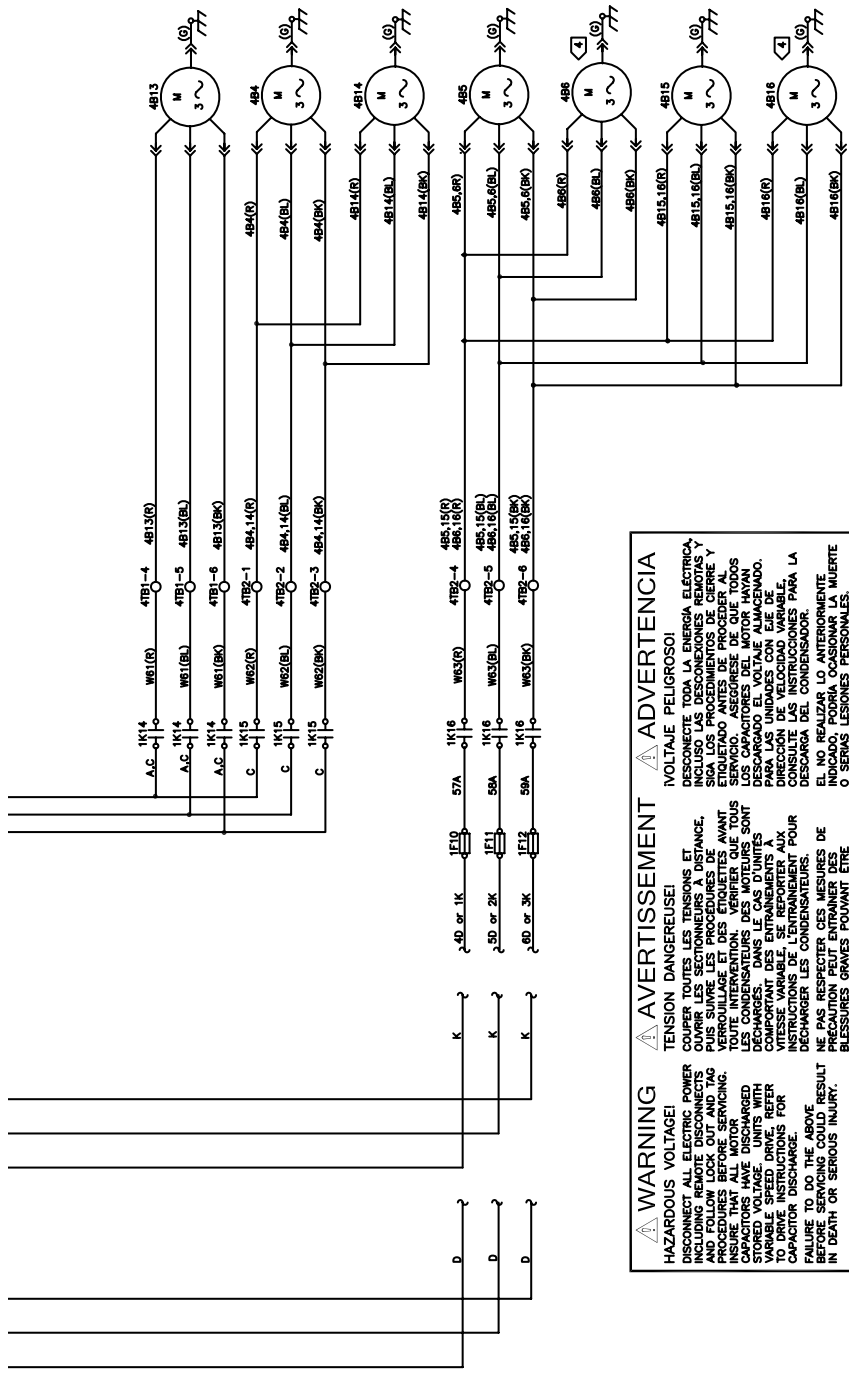


**CAUTION**  
 USE COPPER CONDUCTORS ONLY!  
 UNIT TERMINALS ARE NOT DESIGNED TO ACCEPT OTHER TYPES OF CONDUCTORS.  
 FAILURE TO DO SO MAY CAUSE DAMAGE TO THE EQUIPMENT.

**ATTENTION**  
 N'UTILISER QUE DES CONDUCTEURS EN CUIVRE!  
 LES BORNES DE L'UNITÉ NE SONT PAS CONÇUES POUR RECEVOIR D'AUTRES TYPES DE CONDUCTEURS.  
 L'UTILISATION DE TOUT AUTRE CONDUCTEUR PEUT ENDOMMAGER L'ÉQUIPEMENT.

**PRECAUCIÓN**  
 ¡UTILICE ÚNICAMENTE CONDUCTORES DE COBRE!  
 LAS TERMINALES DE LA UNIDAD NO ESTÁN DISEÑADAS PARA RECIBIR OTROS TIPOS DE CONDUCTORES.  
 SI NO LO HACE, PUEDE OCASIONAR DAÑO AL EQUIPO.

156 —  
 157 —  
 158 —  
 159 —  
 160 —  
 161 —  
 162 —  
 163 —  
 164 —  
 165 —  
 166 —  
 167 —  
 168 —  
 169 —  
 170 —  
 171 —  
 172 —  
 173 —  
 174 —  
 175 —  
 176 —  
 177 —  
 178 —  
 179 —  
 180 —



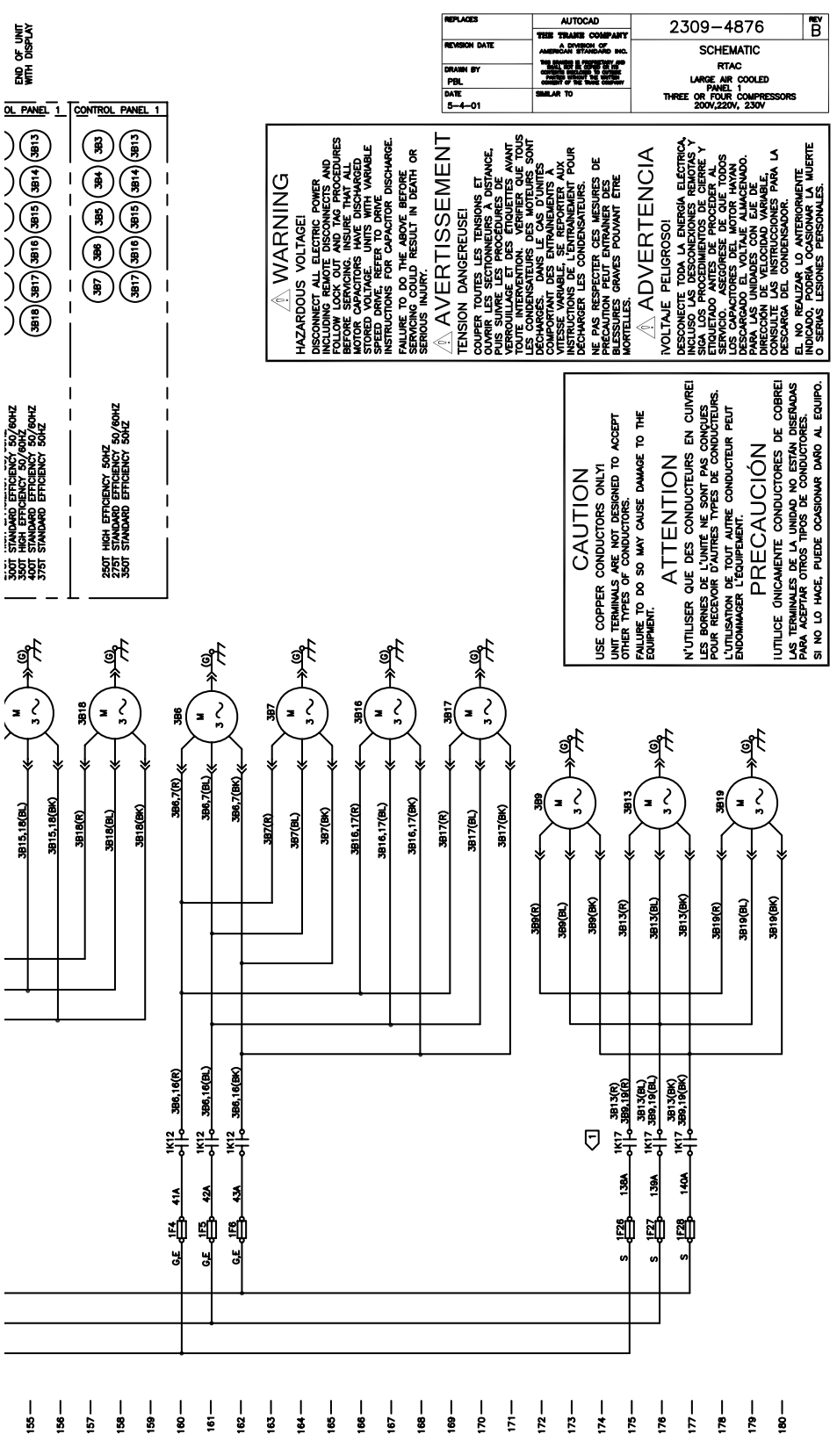
REPLACES	AUTOCAD	2309-2231	REV 1
REVISION DATE 6-6-01	THE STRAKE COMPANY A DIVISION OF AMERICAN STANDARD, INC. 10000 W. 10TH AVENUE DENVER, COLORADO 80231 TEL: 303-750-1000 FAX: 303-750-1001	SCHMATIC	
DRAWN BY PJM	SIMILAR TO	RTAC 2 COMPRESSOR LARGE AIR COOLED FANS 225/250T PREMIUM 60HZ	
DATE 10-25-00			

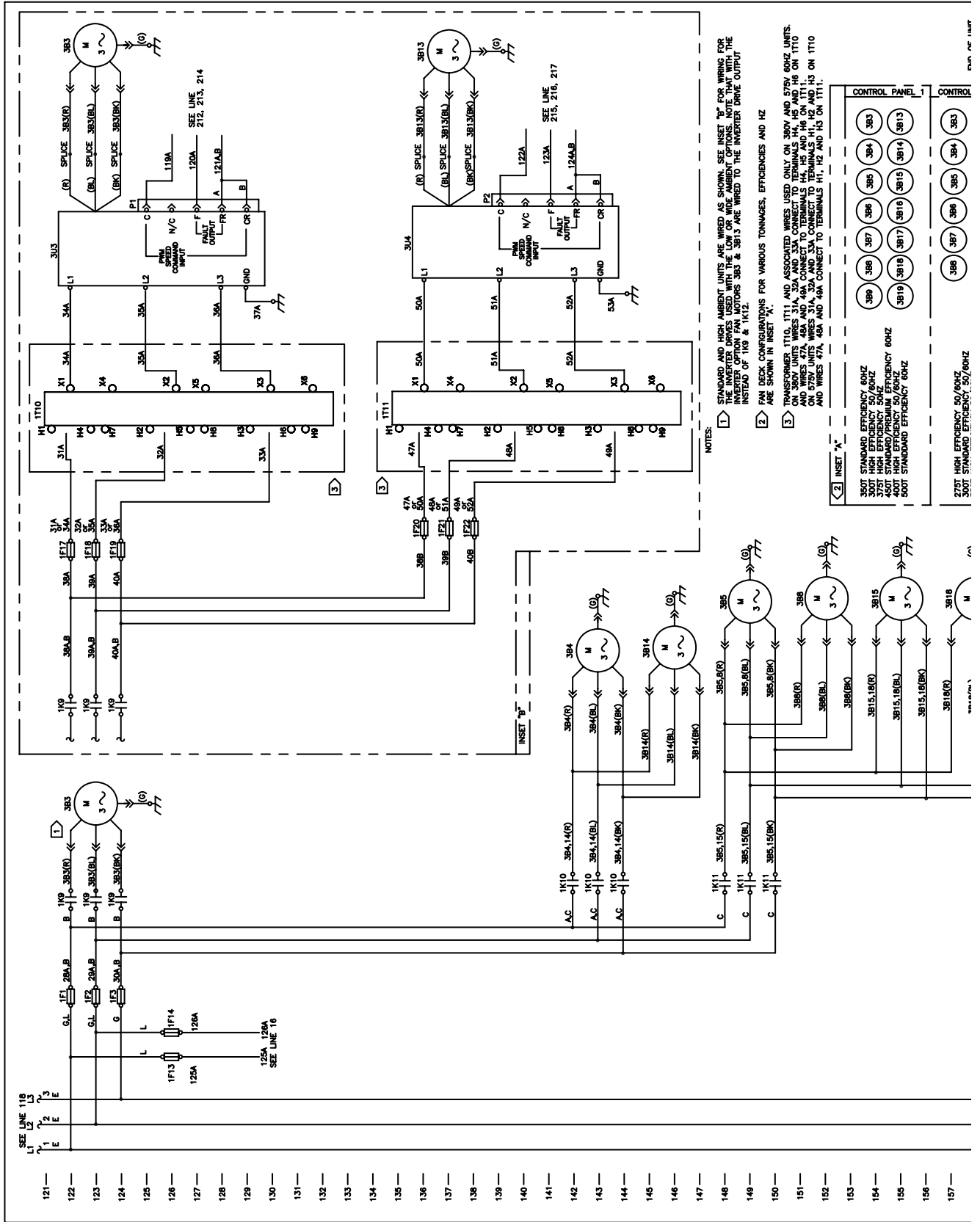
**HAZARDOUS VOLTAGE!** POWER INCLUDING REMOTE DISCONNECTS AND FOLLOW LOCK OUT AND TAG PROCEDURES BEFORE SERVICING. CAPACITORS HAVE DISCHARGED STORED VOLTAGE. UNITS WITH VARIABLE SPEED DRIVE REFER TO INSTRUCTIONS FOR CAPACITOR DISCHARGE. FAILURE TO DO THE ABOVE BEFORE SERVICING COULD RESULT IN DEATH OR SERIOUS INJURY.

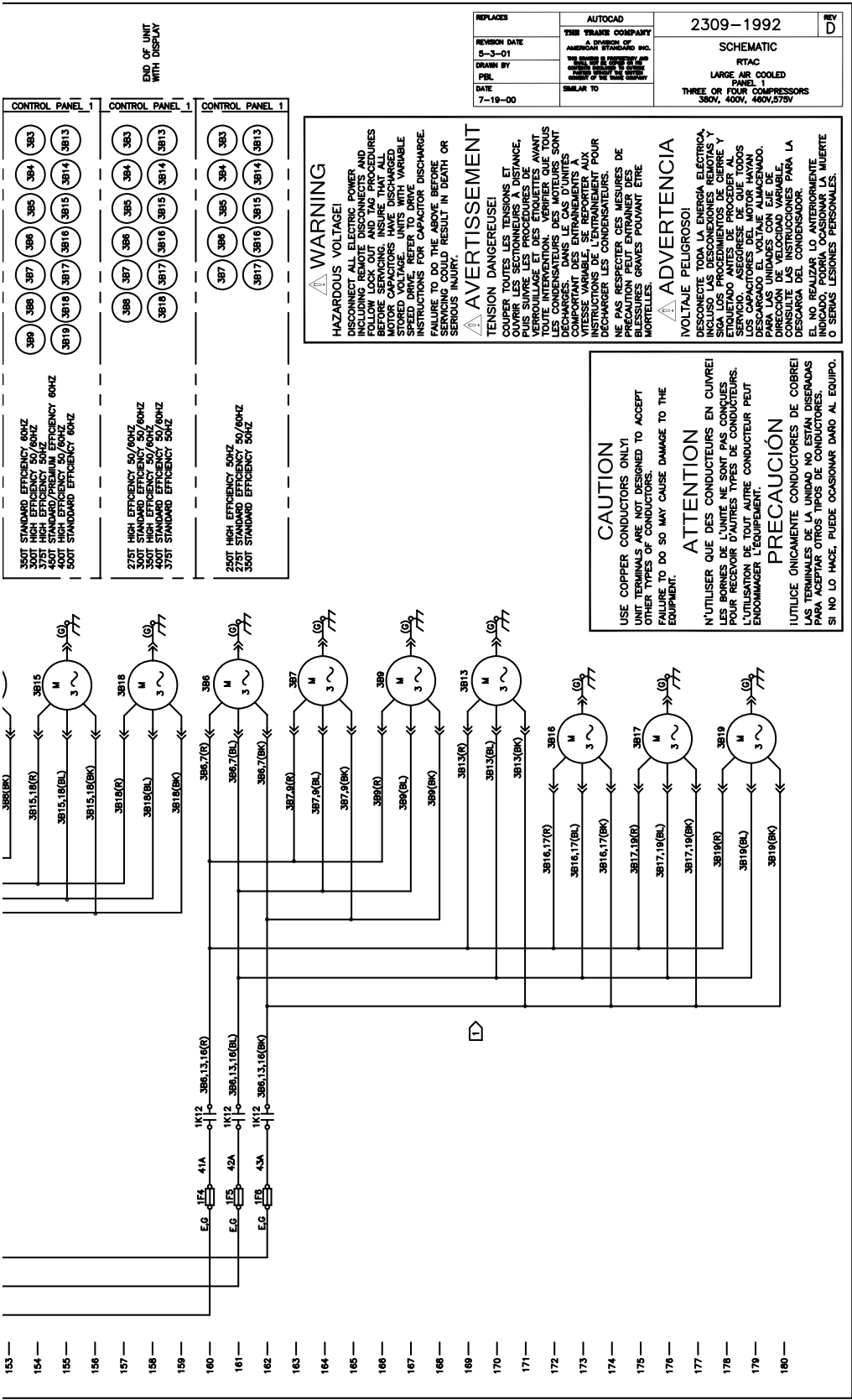
**AVERTISSEMENT** TENSION DANGEREUSE! OUVRIER LES SECTIONNEURS ET PLUS SUIVRE LES PROCEDURES DE VERROUILLAGE ET DES ETIQUETTES AVANT DE TRAVAILLER. LES CONDENSATEURS DES MOTEURS SONT DECHARGES. DANS LE CAS D'UNITES A COMMANDE A VITESSE VARIABLE, VOIR LES INSTRUCTIONS DE L'ENTRAINEMENT POUR DECHARGER LES CONDENSATEURS. NE PAS RESPECTER CES MESURES DE SECURITE AVANT DE COMMENCER LE TRAVAIL PEUT ENTRAÎNER DES BLESSURES GRAVES POUVANT ETRE MORTELLES.

**ADVERTENCIA** VOLTAJE PELIGROSO! DESCONECTE LOS SECCIONNEURS ELECTRICOS INCLUIDO LAS DESCONEXIONES REMOTAS Y SIGA LOS PROCEDIMIENTOS DE CIERRE Y ETIQUETADO ANTES DE PROCEDER AL TRABAJO. LOS CONDENSADORES DEL MOTOR HAYAN DESCARGADO EL VOLTAJE ALMACENADO. PARA LAS UNIDADES CON VELOCIDAD VARIABLE, CONSULTE LAS INSTRUCCIONES PARA LA DESCARGA DEL CONDENSADOR. EL NO REALIZAR LO ANTERIORMENTE INDICADO PODRIA CAUSAR LA MUERTE O SERIAS LESIONES PERSONALES.









REPLACES	AUTOCAD	2309-1992	D
REVISION DATE	THE TRANE COMPANY	SCHEMATIC	
5-3-01	AMERICAN STANDARD INC.	RTAC	
DRAWN BY	TRANE	LARGE AIR COOLED	
PBL	TRANE	THREE OR FOUR COMPRESSORS	
DATE	7-19-00	380V, 400V, 480V, 575V	

**⚠ WARNING**  
 HAZARDOUS VOLTAGE!  
 DISCONNECT ALL ELECTRIC POWER INCLUDING REMOTE DISCONNECTS AND CAPACITORS FROM ALL UNITS BEFORE SERVICING. INSURE THAT MOTOR CAPACITORS HAVE DISCHARGED. SERVICING UNITS WITH VARIABLE STORED VOLTAGE. UNITS WITH VARIABLE STORED VOLTAGE MUST FOLLOW THE INSTRUCTIONS FOR CAPACITOR DISCHARGE. FAILURE TO DO THE ABOVE BEFORE SERVICING COULD RESULT IN DEATH OR SERIOUS INJURY.

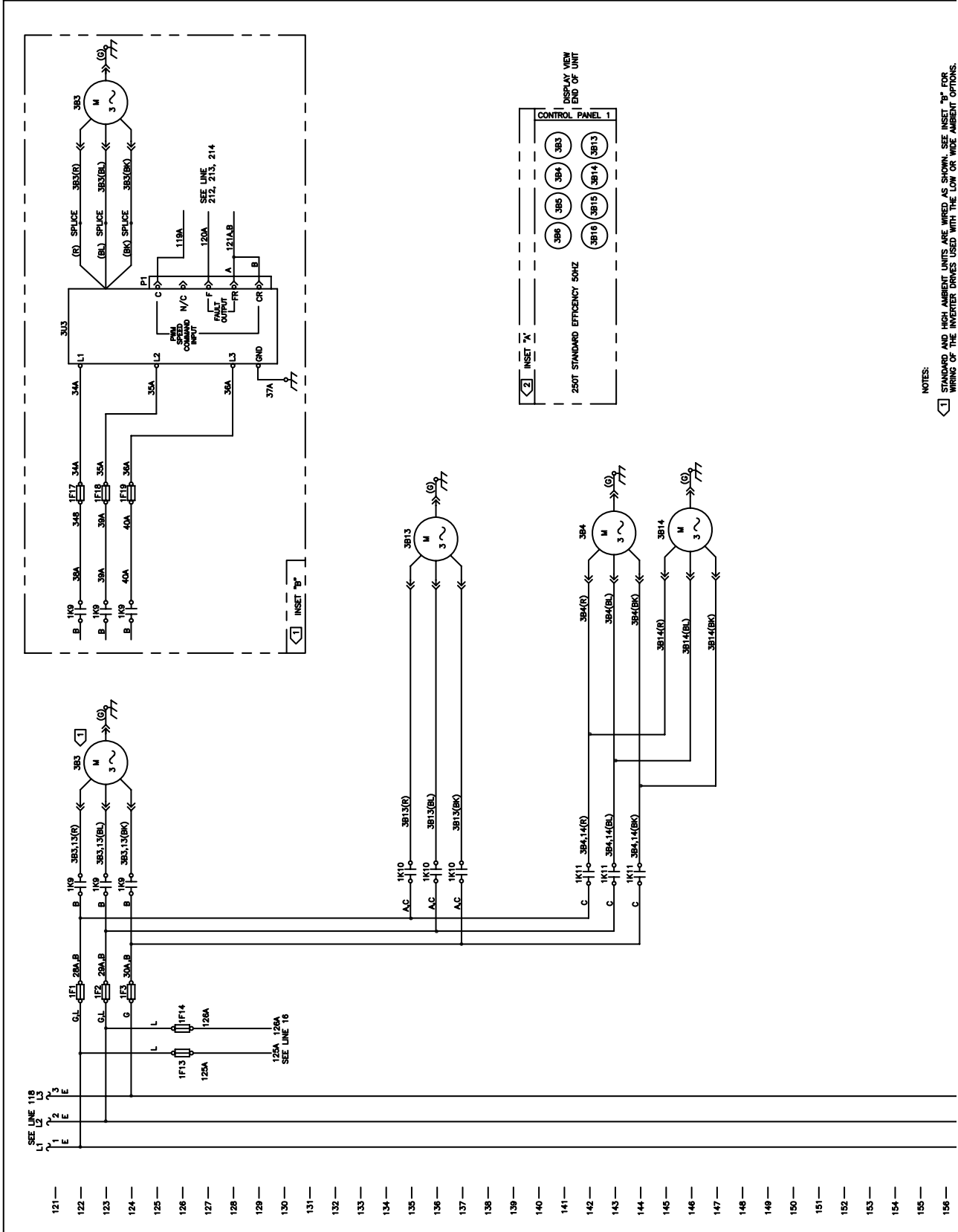
**⚠ AVERTISSEMENT**  
 TENSION DANGEREUSE!  
 DÉCONNECTER TOUS LES ÉLÉMENTS ET LES CONDENSATEURS D'ÉNERGIE AVANT DE RÉPARER. ASSURER QUE LES CONDENSATEURS DES MOTEURS DÉCHARGÉS. DANS LE CAS D'UNITÉS À TENSION VARIABLE À STOCKAGE D'ÉNERGIE, SUIVRE LES INSTRUCTIONS DE DÉCHARGEMENT POUR DÉCHARGER LES CONDENSATEURS. NE PAS RESPECTER CES MESURES DE PRÉCAUTION PEUT ENTRAINER DES BLESSURES GRAVES POUVANT ÊTRE MORTELLES.

**⚠ ADVERTENCIA**  
 ¡VOLTAJE PELIGROSO!  
 DESCONECTE TODA LA ENERGÍA ELÉCTRICA, INCLUIDO LAS DESCONEXIONES REMOTAS Y LOS CONDENSADORES DE LOS MOTORES ANTES DE PROCEDER AL SERVICIO. ASEGÚRESE DE QUE TODOS LOS CAPACITORES DEL MOTOR HAYAN SIDO DESCARGADOS. EN EL CASO DE UNIDADES CON TENSION VARIABLE, SIGA LAS INSTRUCCIONES PARA LA DIRECCION DE VELOCIDAD VARIABLE. CONSULTAR LAS INSTRUCCIONES PARA LA DIRECCION DE VELOCIDAD VARIABLE. SI NO SE REALIZAN LAS PRECAUCIONES INDICADAS, PODRIA OCASIONAR LA MUERTE O SERIAS LESIONES PERSONALES.

**CAUTION**  
 USE COPPER CONDUCTORS ONLY!  
 UNIT TERMINALS ARE NOT DESIGNED TO ACCEPT OTHER TYPES OF CONDUCTORS.  
 FAILURE TO DO SO MAY CAUSE DAMAGE TO THE EQUIPMENT.

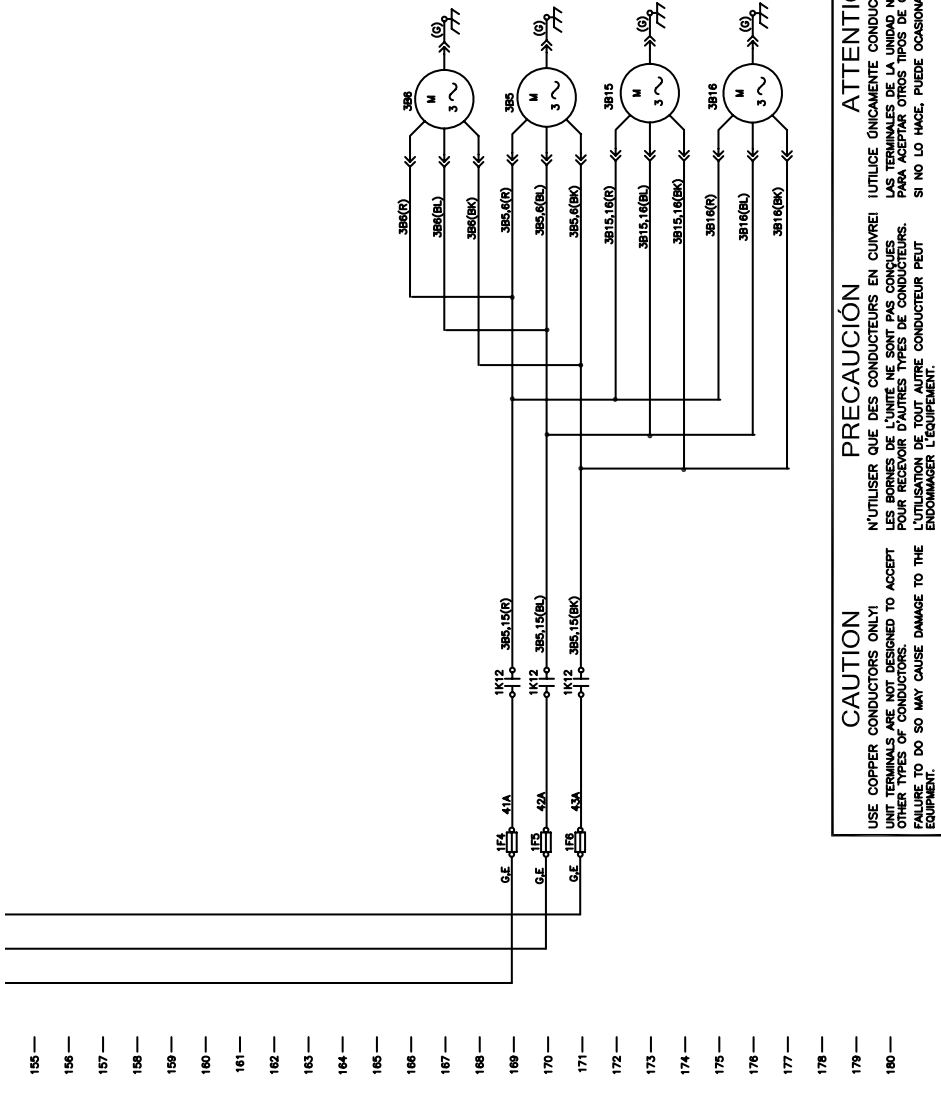
**ATTENTION**  
 N'UTILISER QUE DES CONDUCTEURS EN CUIVRE!  
 LES BORNES DE L'UNITÉ NE SONT PAS CONÇUES POUR RECEVOIR D'AUTRES TIPIES DE CONDUCTEURS.  
 L'UTILISATION D'UN AUTRE TIPIE DE CONDUCTEUR PEUT ENDOMMAGER L'ÉQUIPEMENT.

**PRECAUCIÓN**  
 ¡UTILICE ÚNICAMENTE CONDUCTORES DE COBRE!  
 LAS TERMINALES DE LA UNIDAD NO ESTÁN DISEÑADAS PARA ACEPTAR OTROS TIPOS DE CONDUCTORES.  
 SI NO LO HACE, PUEDE OCASIONAR DAÑO AL EQUIPO.



NOTES:  
 1 STANDARDS AND HIGH AMBERT UNITS ARE WIRED AS SHOWN. SEE INSET #2 FOR WIRING OF THE INVERTER DRIVES USED WITH THE LOW OR WIRE ABSENT OPTIONS.  
 2 INSET #2  
 3 INSET #3  
 4 INSET #4  
 5 INSET #5  
 6 INSET #6  
 7 INSET #7  
 8 INSET #8  
 9 INSET #9  
 10 INSET #10  
 11 INSET #11  
 12 INSET #12  
 13 INSET #13  
 14 INSET #14  
 15 INSET #15  
 16 INSET #16  
 17 INSET #17  
 18 INSET #18  
 19 INSET #19  
 20 INSET #20  
 21 INSET #21  
 22 INSET #22  
 23 INSET #23  
 24 INSET #24  
 25 INSET #25  
 26 INSET #26  
 27 INSET #27  
 28 INSET #28  
 29 INSET #29  
 30 INSET #30  
 31 INSET #31  
 32 INSET #32  
 33 INSET #33  
 34 INSET #34  
 35 INSET #35  
 36 INSET #36  
 37 INSET #37  
 38 INSET #38  
 39 INSET #39  
 40 INSET #40  
 41 INSET #41  
 42 INSET #42  
 43 INSET #43  
 44 INSET #44  
 45 INSET #45  
 46 INSET #46  
 47 INSET #47  
 48 INSET #48  
 49 INSET #49  
 50 INSET #50  
 51 INSET #51  
 52 INSET #52  
 53 INSET #53  
 54 INSET #54  
 55 INSET #55  
 56 INSET #56  
 57 INSET #57  
 58 INSET #58  
 59 INSET #59  
 60 INSET #60

- NOTES:
- 1 STANDARD AND HIGH AMBIENT UNITS ARE WIRED AS SHOWN. SEE INSET "B" FOR WIRING OF THE INVERTER DRIVE OPTION WITH THE LOW OR WIDE AMBIENT OPTIONS.
  - 2 FOR FAN DECK CONFIGURATION SEE INSET "A".



**WARNING**  
 HAZARDOUS VOLTAGE!  
 DISCONNECT ALL ELECTRIC POWER INCLUDING REMOTE DISCONNECTS AND FLOW SWITCHES FROM ALL UNITS BEFORE SERVICING. INSURE THAT MOTOR CAPACITORS HAVE DISCHARGED STORED VOLTAGE. SERVICING UNITS WITH VARIABLE SPEED DRIVES MUST FOLLOW THE INSTRUCTIONS FOR CAPACITOR DISCHARGE FAILURE TO DO THE ABOVE BEFORE SERVICING COULD RESULT IN DEATH OR SERIOUS INJURY.

**AVERTISSEMENT**  
 TENSION DANGEREUSE!  
 COUPER TOUTES LES DISTRIBUIONS ET FLOW SWITCHES AVANT LE TRAVAIL. ASSURER LA DISTANCE, VÉRIFICATION ET DES ÉTIQUETTES AVANT LE TRAVAIL. LES CONDENSATEURS DES MOTEURS SONT DÉCHARGÉS. DANS LE CAS D'UNITÉS À VITESSE VARIABLE, SUIVRE LES INSTRUCTIONS DE L'ENTRAÎNEMENT POUR DÉCHARGER LES CONDENSATEURS. NE PAS RESPECTER CES MESURES DE PRÉCAUTION PEUT ENTRAINER DES BLESSURES GRAVES POUVANT ÊTRE MORTELLES.

**ADVERTENCIA**  
 VOLTAJE PELIGROSO!  
 DESCONECTE TODA LA ENERGÍA ELÉCTRICA INCLUIDO LAS DESCONEXIONES REMOTAS Y FLOW SWITCHES ANTES DE PROCEDER AL SERVICIO. ASEGURESE DE QUE TODOS LOS CAPACITORES DEL MOTOR HAYAN DESCARGADO LA ENERGÍA ALMACENADA. PARA LAS UNIDADES CON ELE DE VELOCIDAD VARIABLE, CONSULTE LAS INSTRUCCIONES PARA LA DESCARGA DE LOS CONDENSADORES. EN LOS CASOS DE UNIDADES A VARIANTE INDICADO, PODRÁ OCASIONAR LA MUERTE O SERIAS LESIONES PERSONALES.

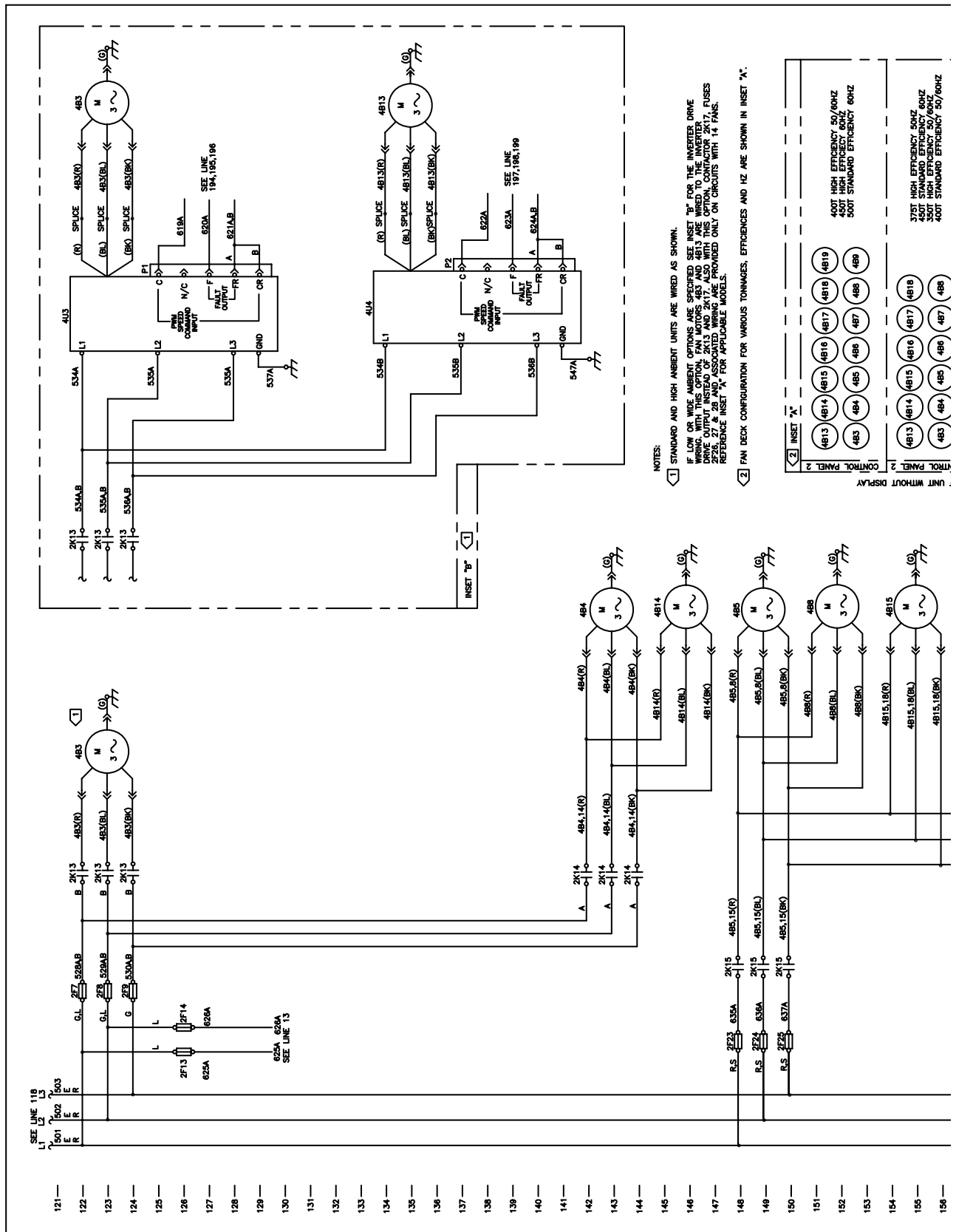
REPLACES	AUTOCAD	2309-2217	REV
REVISION DATE	THE TRANE COMPANY		C
DRAWN BY	AMERICAN OVERSEAS INC.		
PBL	TRANE TRANE COMPANY		
DATE	SIMILAR TO		
7-19-00			

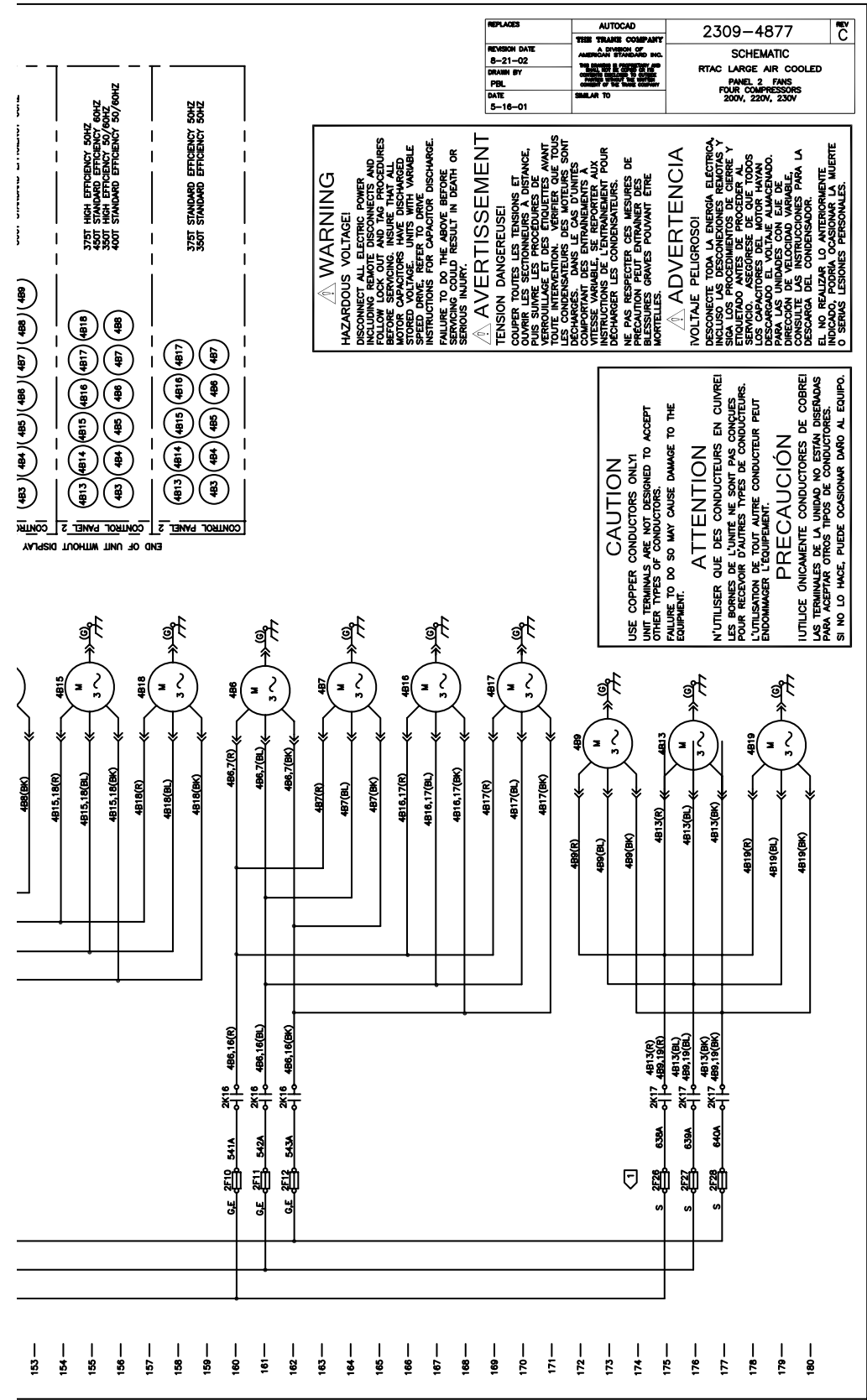
**SCHEMATIC**  
 RTAC  
 LARGE AIR COOLED  
 PANEL FANS  
 250T 50HZ STANDARD EFFICIENCY  
 THREE COMPRESSORS

**CAUTION**  
 USE COPPER CONDUCTORS ONLY!  
 UNIT TERMINALS ARE NOT DESIGNED TO ACCEPT OTHER TYPES OF CONDUCTORS.  
 FAILURE TO DO SO MAY CAUSE DAMAGE TO THE EQUIPMENT.

**PRECAUCIÓN**  
 N'UTILISER QUE DES CONDUCTEURS EN CUIVRE!  
 LES BORNES DE L'UNITÉ NE SONT PAS CONÇUES POUR RECEVOIR D'AUTRES TYPES DE CONDUCTEURS.  
 L'UTILISATION DE TOUT AUTRE CONDUCTEUR PEUT ENDOMMAGER L'EQUIPEMENT.

**ATTENTION**  
 UTILISEZ UNICAMENTE CONDUCTORES DE COBRE!  
 LAS TERMINALES DE LA UNIDAD NO ESTÁN DISEÑADAS PARA ACEPTAR OTROS TIPOS DE CONDUCTORES.  
 SI NO LO HACE, PUEDE OCASIONAR DAÑO AL EQUIPO.





- END OF UNIT WITHOUT DISPLAY
- CONTROL PANEL 2
- CONTROL PANEL 2
- (483) (484) (485) (486) (487) (488) (489)
  - (4813) (4814) (4815) (4816) (4817) (4818)
  - (483) (484) (485) (486) (487) (488)
  - (4813) (4814) (4815) (4816) (4817) (4818)
  - (483) (484) (485) (486) (487) (488)
- 375T HIGH EFFICIENCY 50HZ  
450T STANDARD EFFICIENCY 60HZ  
350T HIGH EFFICIENCY 50/60HZ  
400T STANDARD EFFICIENCY 50/60HZ
- 375T STANDARD EFFICIENCY 50HZ  
350T STANDARD EFFICIENCY 50HZ

REPLACES	AUTOCAD	2309-4877	C
REVISION DATE	THE TRANE COMPANY		
3-21-02	AMERICAN REFERENCE NO.		
DRAWN BY	DATE		
PRL	5-16-01		
	SIMILAR TO		

SCHMATIC  
RTAC LARGE AIR COOLED  
PANEL 2 FANS  
FOUR COMPRESSORS  
200V, 230V, 230V

**⚠ WARNING**  
HAZARDOUS VOLTAGE!  
DISCONNECT ALL ELECTRIC POWER FROM THE UNIT BEFORE SERVICING. FOLLOW LOCK OUT AND TAG PROCEDURES BEFORE SERVICING. INSURE THAT ALL SCREWDRIVERS AND OTHER METAL TOOLS ARE PROPERLY GROUNDED. DO NOT TOUCH ANY UNLabeled WIRING OR ELECTRICAL COMPONENTS WHILE THE UNIT IS ENERGIZED. REFER TO DRIVE INSTRUCTIONS FOR CAPACITOR DISCHARGE. FAILURE TO DO THE ABOVE BEFORE SERVICING MAY CAUSE DEATH OR SERIOUS INJURY.

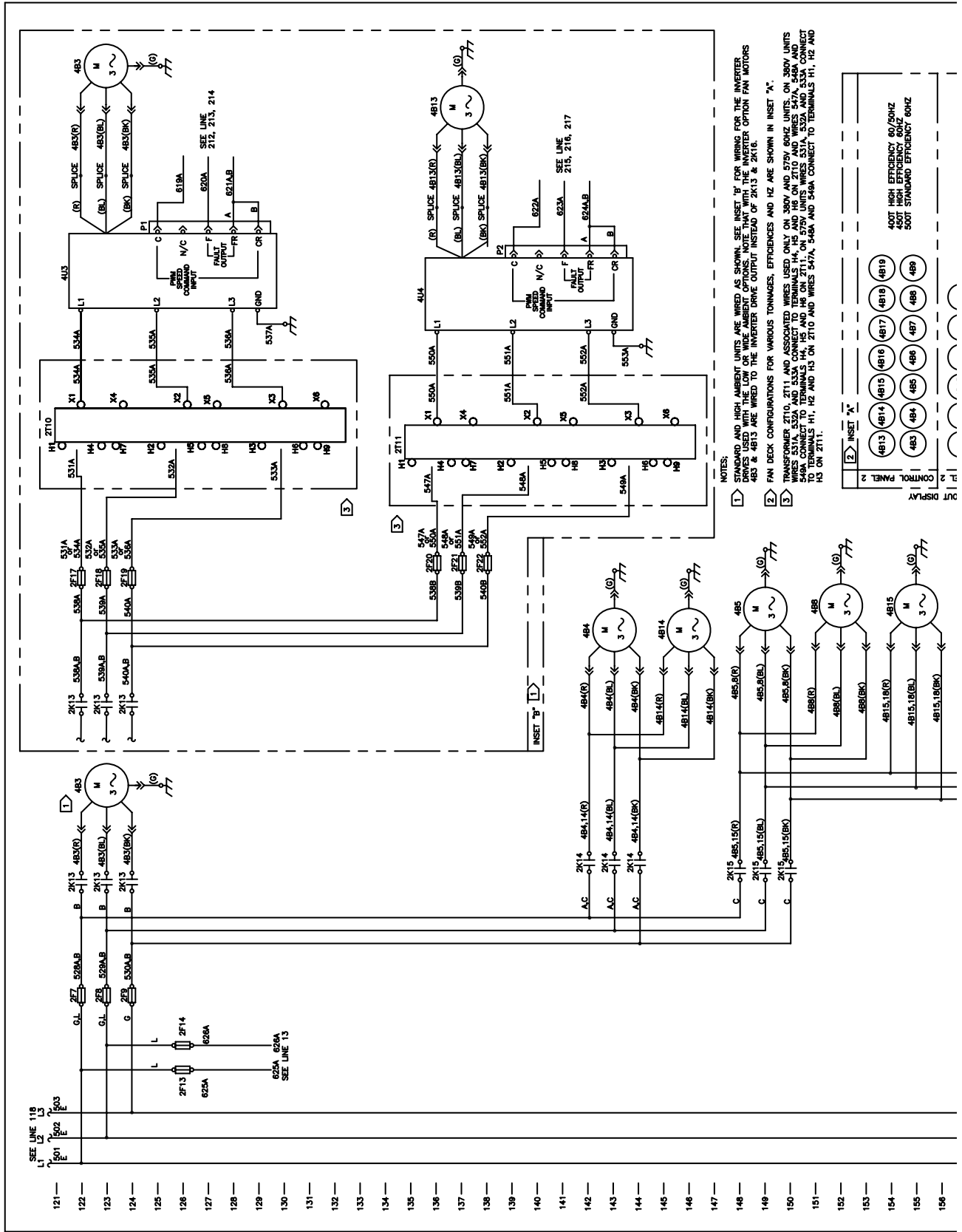
**⚠ AVERTISSEMENT**  
TENSION DANGEREUSE!  
COUPER TOUTES LES TENSIONS ET COUVRIR LES SECTIONNEURS A DISTANCE. PUIS SUIVRE LES PROCEDURES DE LOCK OUT ET TAG AVANT TOUTE INTERVENTION. ASSURER QUE TOUTES LES Outils METALLIQUES SONT BIEN GROUNDÉS. NE PAS TOUCHER LES CÂBLES NON ÉTIQUETÉS NI LES COMPOSANTS ÉLECTRIQUES TANT QUE L'UNITÉ EST ENERGIZÉE. SE REPORTER AUX INSTRUCTIONS DE L'ENTRAÎNEMENT POUR DÉCHARGER LES CONDENSATEURS. L'ÉCHÉC À SUIVRE LES PROCÉDURES CI-DESSUS PEUT CAUSER LA MORT OU DES BLESSURES GRAVES POUVANT ÊTRE MORTELLES.

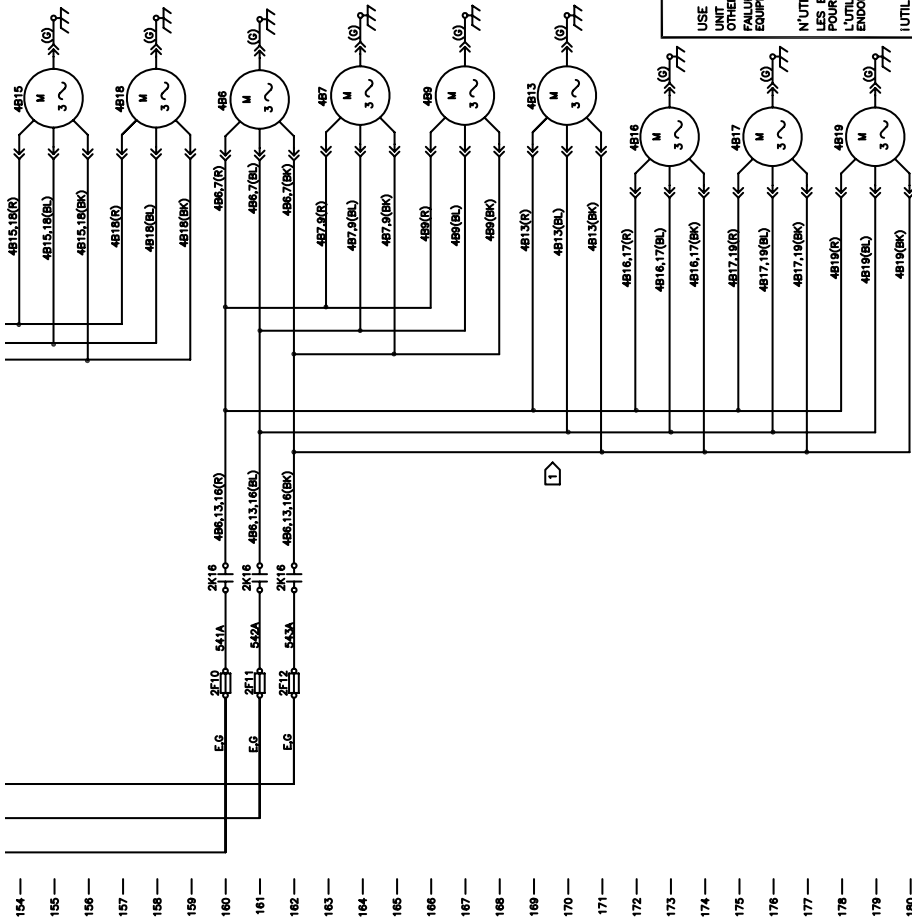
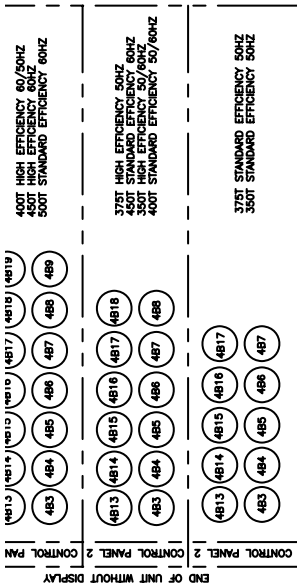
**⚠ ADVERTENCIA**  
VOLTAJE PELIGROSO!  
DESCONECTE TODA LA ENERGÍA ELÉCTRICA DE LA UNIDAD ANTES DE SERVICIAR. SIGA LOS PROCEDIMIENTOS DE CIERRE Y ETIQUETADO ANTES DE PROCEDER AL SERVICIO. ASEGURE QUE TODOS LOS Outils METÁLICOS ESTÉN BIEN GROUNDADOS. NO TOQUE NINGUNA WIRING O COMPONENTES ELÉCTRICOS MIENTRAS LA UNIDAD ESTÉ ENERGIZADA. CONSULTE LAS INSTRUCCIONES PARA LA DESCARGA DEL CONDENSADOR. EL NO REALIZAR LO ANTERIORMENTE INDICADO, PODRÁ OCASIONAR LA MUERTE O SERIAS LESIONES PERSONALES.

**CAUTION**  
USE COPPER CONDUCTORS ONLY!  
UNIT TERMINALS ARE NOT DESIGNED TO ACCEPT OTHER TYPES OF CONDUCTORS.  
FAILURE TO DO SO MAY CAUSE DAMAGE TO THE EQUIPMENT.

**ATTENTION**  
N'UTILISER QUE DES CONDUCTEURS EN CUIVRE!  
LES BORNES DE L'UNITÉ NE SONT PAS CONÇUES POUR RECEVOIR D'AUTRES TYPES DE CONDUCTEURS.  
L'UTILISATION DE TOUT AUTRE CONDUCTEUR PEUT ENDOMMAGER L'ÉQUIPEMENT.

**PRECAUCIÓN**  
UTILICE ÚNICAMENTE CONDUCTORES DE COBRE!  
LAS TERMINALES DE LA UNIDAD NO ESTÁN DISEÑADAS PARA RECIBIR OTROS TIPOS DE CONDUCTORES.  
SI NO LO HACE, PUEDE OCASIONAR DAÑO AL EQUIPO.





REPLACES	AUTOCAD	2309-2205	REV
REVISION DATE	THE TRANE COMPANY DIVISION OF AMERICAN OVERSEAS INC.	SCHEMATIC	C
DRAWN BY	RTAC LARGE AIR COOLED FAN PANEL 2 FANS FOUR COMPRESSORS 380V, 400V, 480V, 575V		
DATE	7-28-00		

**⚠ WARNING**  
 HAZARDOUS VOLTAGE!  
 DISCONNECT ALL ELECTRICAL POWER, INCLUDING REMOTE DISCONNECTS, AND FOLLOW LOCK OUT AND TAG PROCEDURES BEFORE SERVICING. INSURE THAT ALL CAPACITORS ARE FULLY CHARGED AND STORED VOLTAGE UNITS WITH VARIABLE SPEED DRIVE. REFER TO DRIVE INSTRUCTIONS FOR CAPACITOR DISCHARGE. FAILURE TO DO THE ABOVE BEFORE SERVICING COULD RESULT IN DEATH OR SERIOUS INJURY.

**⚠ AVERTISSEMENT**  
 TENSION DANGEREUSE!  
 COUPER TOUTES LES TENSIONS ET OUVRIER LES SECTIONNEURS A DISTANCE. NE PAS TOUCHER LES DISPOSITIFS DE VERROUILLAGE ET DES ETIQUETTES AVANT TOUTE INTERVENTION. VERIFIER QUE TOUTS LES CONDENSATEURS DES MOTEURS SONT COMPLETEMENT CHARGES. LES UNITES A VITESSE VARIABLE, SE REPORTER AUX INSTRUCTIONS DE LA LITRATURE POUR LA DISCHARGE DES CAPACITATEURS. NE PAS RESPECTER CES MESURES DE PRECAUTION PEUT ENTRAINER DES BLESSURES GRAVES POUVANT ETRE MORTELLES.

**⚠ ADVERTENCIA**  
 VOLTAJE PELIGROSO!  
 CORTAR TODAS LAS TENSIONES ELECTRICAS INCLUIDO LAS DESCONEXIONES REMOTAS Y SIGA LOS PROCEDIMIENTOS DE CIERRE Y ETIQUETADO ANTES DE PROCEDER AL SERVICIO. ASEGURESE DE QUE TODOS LOS CAPACITORES DEL MOTOR HAYAN DESCARGADO EL VOLTAJE ALMACENADO. PARA LAS UNIDADES CON VELOCIDAD VARIABLE, REFERIRSE A LAS INSTRUCCIONES PARA LA DESCARGA DEL CONDENSADOR. EL NO REALIZAR LO ANTERIORMENTE INCLUIDO EN LA LITRATURA PUEDE CAUSAR LA MUERTE O SERIAS LESIONES PERSONALES.

**CAUTION**  
 USE COPPER CONDUCTORS ONLY!  
 UNIT TERMINALS ARE NOT DESIGNED TO ACCEPT OTHER TYPES OF CONDUCTORS.  
 FAILURE TO DO SO MAY CAUSE DAMAGE TO THE EQUIPMENT.

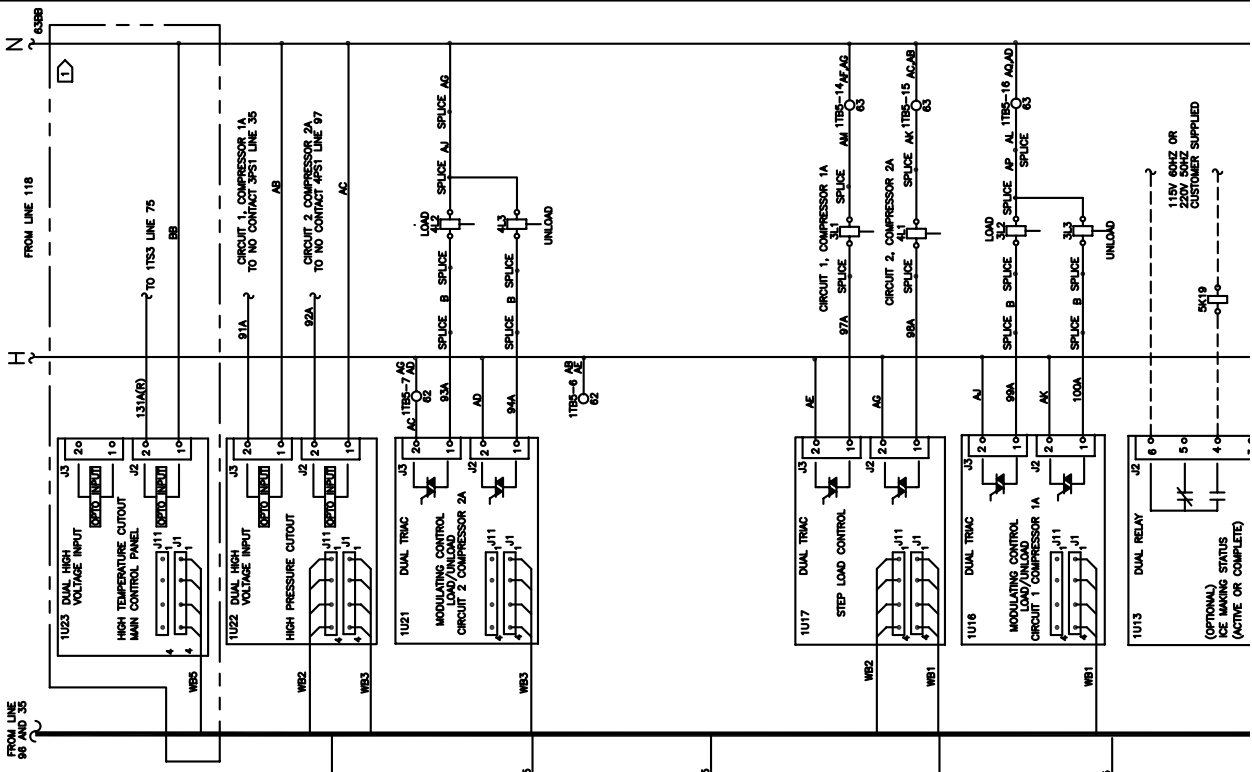
**ATTENTION**  
 N'UTILISER QUE DES CONDUCTEURS EN CUIVRE!  
 LES BORNES DE L'UNITÉ NE SONT PAS CONÇUES POUR RECEVOIR D'AUTRES TYPES DE CONDUCTEURS.  
 L'UTILISATION DE TOUT AUTRE CONDUCTEUR PEUT ENDOMMAGER L'EQUIPEMENT.

**PRECAUCIÓN**  
 ¡UTILICE ÚNICAMENTE CONDUCTORES DE COBRE!  
 LAS TERMINALES DE LA UNIDAD NO ESTÁN DISEÑADAS PARA ACEPTAR OTROS TIPOS DE CONDUCTORES.  
 SI NO LO HACE, PUEDE OCASIONAR DAÑO AL EQUIPO.

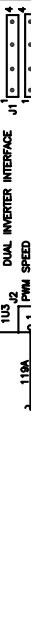
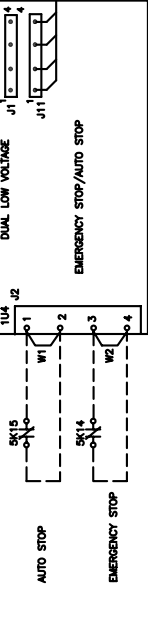
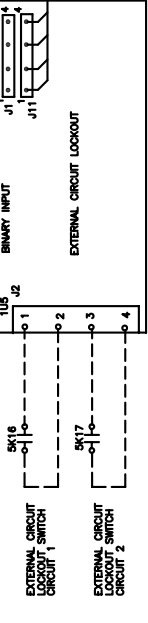
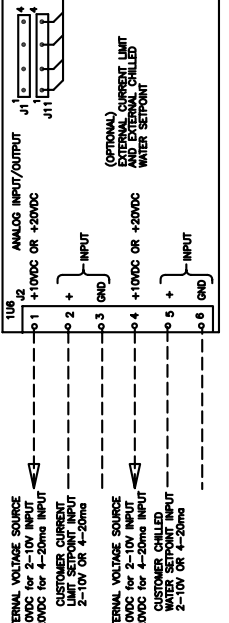
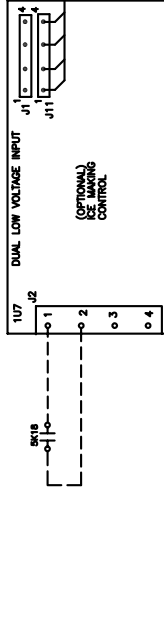
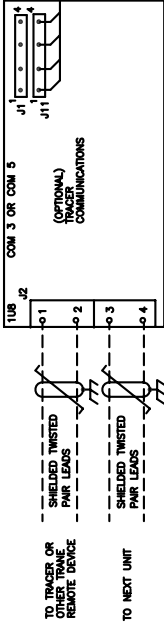
**WARNING** HAZARDOUS VOLTAGE!  
DISCONNECT ALL ELECTRIC POWER INCLUDING REMOTE DISCONNECTS AND FOLLOW LOCK OUT AND TAG PROCEDURES TO ALL WORKING CAPACITORS HAVE DISCHARGED CAPACITORS TESTED BY A QUALIFIED PERSONNEL TO DRIVE INSTRUCTIONS FOR FAILURE TO DO THE ABOVE RESULT IN DEATH OR SERIOUS INJURY.

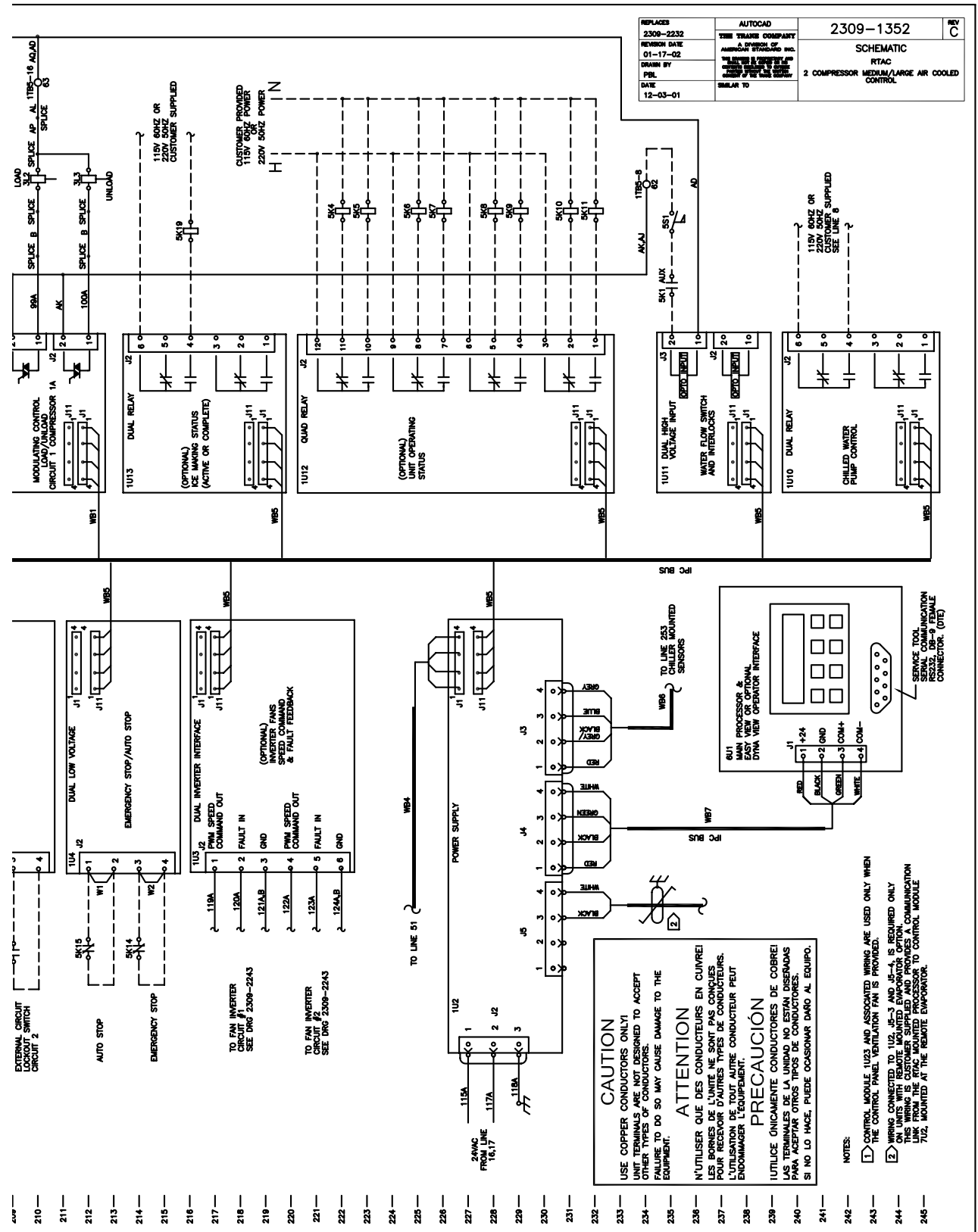
**AVERTISSEMENT** TENSION DANGEREUSE!  
COUPER TOUTES LES TENSIONS ET OUVRIER LES SECTIONNEURS A DISTANCE. SUIVRE LES PROCEDURES DE VERIFICATION DE LA TENSION AVANT TOUTE INTERVENTION. VERIFIER QUE TOUS LES CONDENSATEURS DES MOTEURS SONT DECHARGES ET TESTES PAR UN TECHNICIEN QUALIFIE POUR S'ASSURER QUE LES MOTEURS ONT UN COMPORTEMENT DES ENTRAIEMENTS A VITESSE VARIABLE. SE REPORTER AUX INSTRUCTIONS DE COUPE ET D'ENTRAIEMENT POUR PLUS DE DETAIL. NE PAS RESPECTER CES MESURES DE PRECAUTION PEUT ENTRAINER DES BLESSURES GRAVES POUVANT ETRE MORTELLES.

**ADVERTENCIA** VOLTAJE PELIGROSO!  
DESCONECTE TODA LA ENERGIA ELECTRICA INCLUIDO LAS DESCONEXIONES REMOTAS Y SIGA LOS PROCEDIMIENTOS DE CERRER Y VERIFICAR LA TENSION ANTES DE EMPEZAR CUALQUIER SERVICIO. ASEGURARSE DE QUE TODOS LOS CAPACITORES DEL MOTOR HAYAN SIDO DESCARGADOS Y PRUEBADOS POR UN TECNICO CALIFICADO PARA LAS UNIDADES CON EJE DE DIRECCION DE VELOCIDAD VARIABLE. CONSULTE LAS INSTRUCCIONES PARA LA OBTENCION DE MAS INFORMACION. EL NO REALIZAR LO ANTERIORMENTE INDICADO, PODRIA OCASIONAR LA MUERTE O SERIAS LESIONES PERSONALES.



- 181—
- 182—
- 183—
- 184—
- 185—
- 186—
- 187—
- 188—
- 189—
- 190—
- 191—
- 192—
- 193—
- 194—
- 195—
- 196—
- 197—
- 198—
- 199—
- 200—
- 201—
- 202—
- 203—
- 204—
- 205—
- 206—
- 207—
- 208—
- 209—
- 210—
- 211—
- 212—
- 213—
- 214—
- 215—
- 216—





REPLACES 2309-2232	AUTOCAD	2309-1352	REV C
REVISION DATE 01-17-02	THE TRANE COMPANY	SCHEMATIC	
DRAWN BY FBL	AMERICAN STANDARD, INC.	RTAC	
DATE 12-03-01	AMERICAN STANDARD, INC.	2 COMPRESSOR MEDIUM/LARGE AIR COOLED CONTROL	
SIMILAR TO			

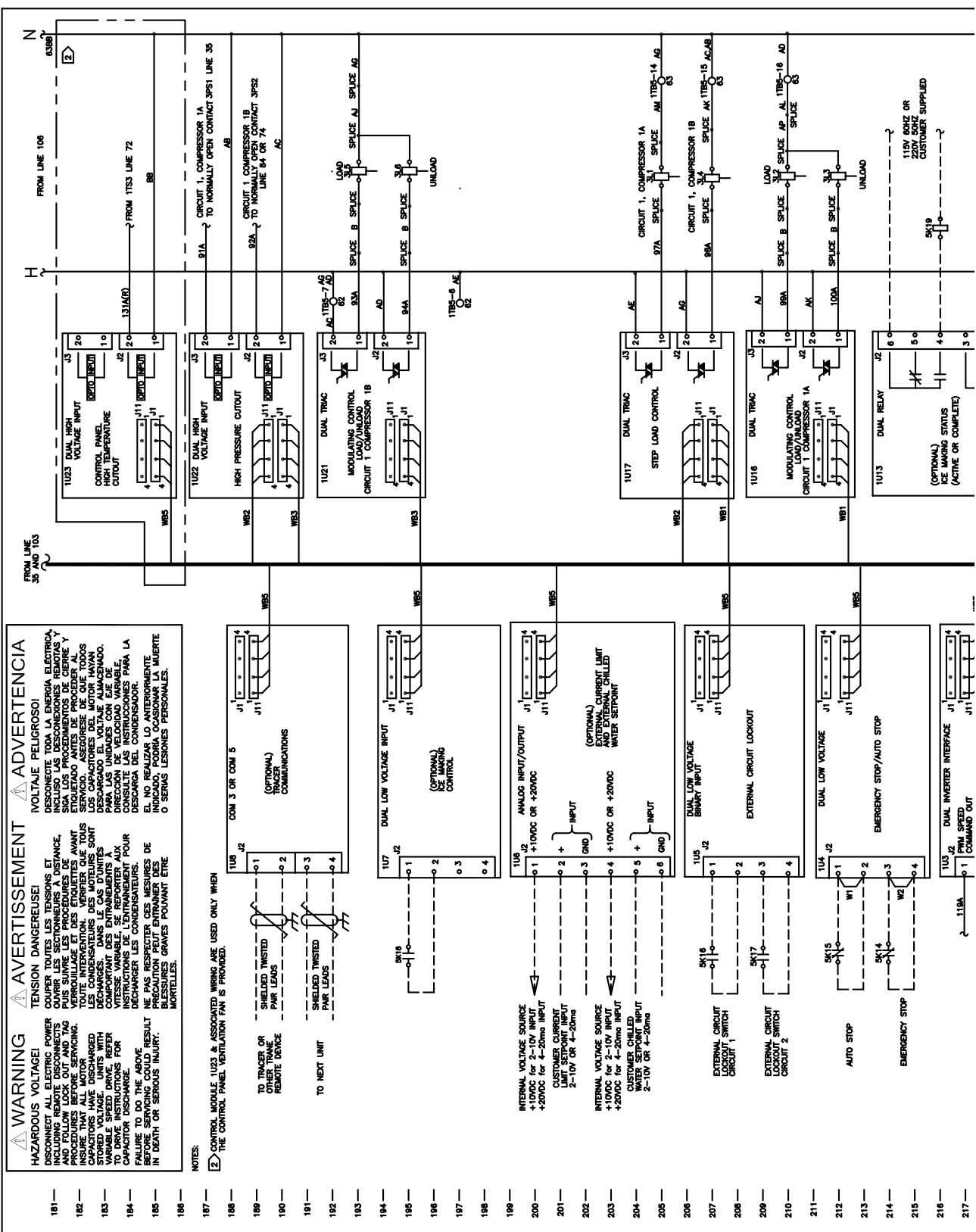
**CAUTION**  
USE COPPER CONDUCTORS ONLY.  
IF TERMINALS ARE DESIGNED TO ACCEPT OTHER TYPES OF CONDUCTORS, FAILURE TO DO SO MAY CAUSE DAMAGE TO THE EQUIPMENT.

**ATTENTION**  
N'UTILISER QUE DES CONDUCTEURS EN CUIVRE!  
LES BORNES DE L'UNITÉ NE SONT PAS CONÇUES POUR RECEVOIR D'AUTRES TYPES DE CONDUCTEURS. L'UTILISATION D'AUTRES CONDUCTEURS PEUT ENDOMMAGER L'ÉQUIPEMENT.

**PRECAUCIÓN**  
UTILICE ÚNICAMENTE CONDUCTORES DE COBRE!  
LAS TERMINALES DE LA UNIDAD NO ESTÁN DISEÑADAS PARA ACEPTAR OTROS TIPOS DE CONDUCTORES. SI NO LO HACE, PUEDE OCASIONAR DAÑO AL EQUIPO.

- NOTES:
- 1 CONTROL MODULE 1U8S AND ASSOCIATED WIRING ARE USED ONLY WHEN THE CONTROL PANEL VENTILATION FAN IS PROVIDED.
  - 2 WIRING CONNECTED TO U10, U11, AND U12 IS REQUIRED ONLY ON UNITS WITH REMOTE MOUNTED EMPLOYER OPTION. THIS WIRING IS CUSTOMER SUPPLIED AND PROVIDES A COMMUNICATION LINK BETWEEN THE REMOTE EMPLOYER TO CONTROL MODULE U12 MOUNTED AT THE REMOTE EMPLOYER.

210 —  
211 —  
212 —  
213 —  
214 —  
215 —  
216 —  
217 —  
218 —  
219 —  
220 —  
221 —  
222 —  
223 —  
224 —  
225 —  
226 —  
227 —  
228 —  
229 —  
230 —  
231 —  
232 —  
233 —  
234 —  
235 —  
236 —  
237 —  
238 —  
239 —  
240 —  
241 —  
242 —  
243 —  
244 —  
245 —



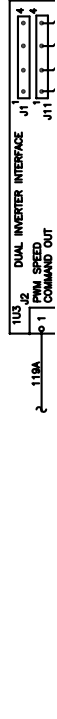
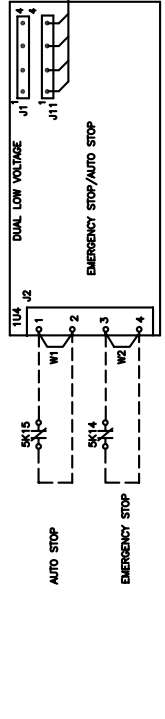
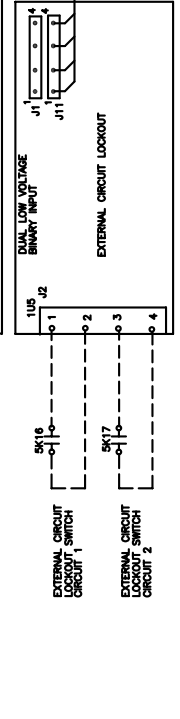
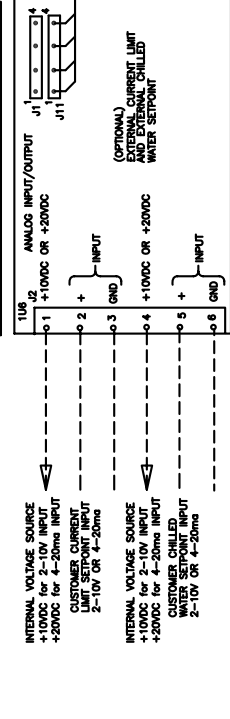
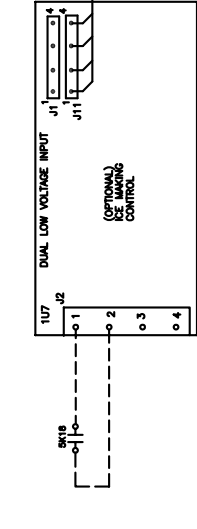
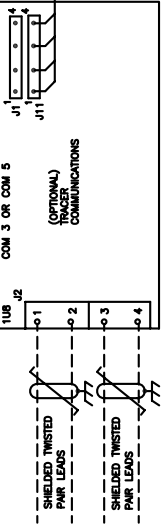
**HAZARDOUS VOLTAGE!**  
DISCONNECT ALL ELECTRIC POWER INCLUDING REMOTE DISCONNECTS AND FUSES BEFORE WORKING.  
INSURE THAT ALL MOTOR CAPACITORS HAVE DISCHARGED TO DRIVE INSTRUCTIONS FOR FAILURE SAFETY MAKE SURE THE FAILURE IS A SHORT CIRCUIT RESULT IN DEATH OR SERIOUS INJURY.

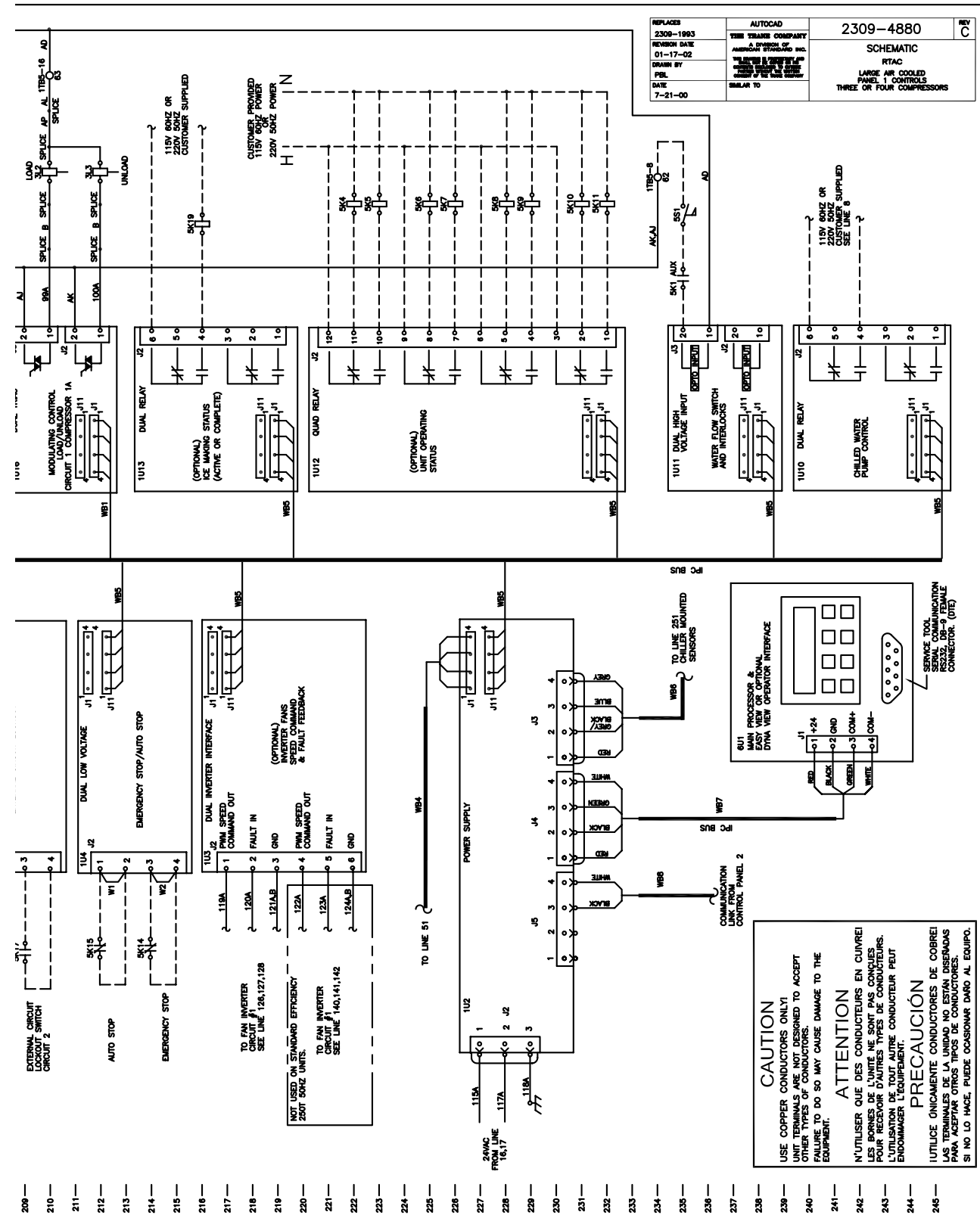
**AVERTISSEMENT**  
TENSION DANGEREUSE!  
COUPER TOUTES LES TENSIONS ET OUVRIER LES SECTIONNEURS A DISTANCE. ASSUREZ-VOUS QUE LES CONDENSATEURS DES MOTEURS SONT DÉCHARGÉS AVANT TOUTE INTERVENTION.  
VÉRIFIEZ QUE TOUTES LES UNITÉS ONT ÉTEINTE LA VITESSE VARIABLE, LA VITESSE VARIABLE, SE REPORTER AUX INSTRUCTIONS DE CONSTRUCTION POUR DÉCHARGER LES CONDENSATEURS. NE PAS RESPECTER CES MESURES DE PRÉCAUTION PEUT ENTRAINER DES BLESSURES GRAVES POUVANT ÊTRE MORTELLES.

**ADVERTENCIA**  
VOLTAJE PELIGROSO!  
DESCONECTE TODA LA ENERGÍA ELÉCTRICA, INCLUIDO LAS DESCONEXIONES REMOTAS Y LOS FUSIBLES ANTES DE PROCEDER AL SERVICIO. ASEGURESE DE QUE TODOS LOS CONDENSADORES DEL MOTOR HAYAN SIDO DESCARGADOS ANTES DE LA INTERVENCIÓN. PARA LAS UNIDADES CON EJE DE DIRECCIÓN DE VELOCIDAD VARIABLE, CONSULTE LAS INSTRUCCIONES PARA LA DESCONEXIÓN DE LA ENERGÍA ELÉCTRICA. EL NO REALIZAR LO ANTERIORMENTE INDICADO, PODRÍA OCASIONAR LA MUERTE O SERIAS LESIONES PERSONALES.

- 181 —
- 182 —
- 183 —
- 184 —
- 185 —
- 186 —
- 187 —
- 188 —
- 189 —
- 190 —
- 191 —
- 192 —
- 193 —
- 194 —
- 195 —
- 196 —
- 197 —
- 198 —
- 199 —
- 200 —
- 201 —
- 202 —
- 203 —
- 204 —
- 205 —
- 206 —
- 207 —
- 208 —
- 209 —
- 210 —
- 211 —
- 212 —
- 213 —
- 214 —
- 215 —
- 216 —
- 217 —

NOTES:  
② CONTROL MODULE 1U23 & ASSOCIATED WIRING ARE USED ONLY WHEN THE CONTROL PANEL VENTILATION FAN IS PROVIDED.



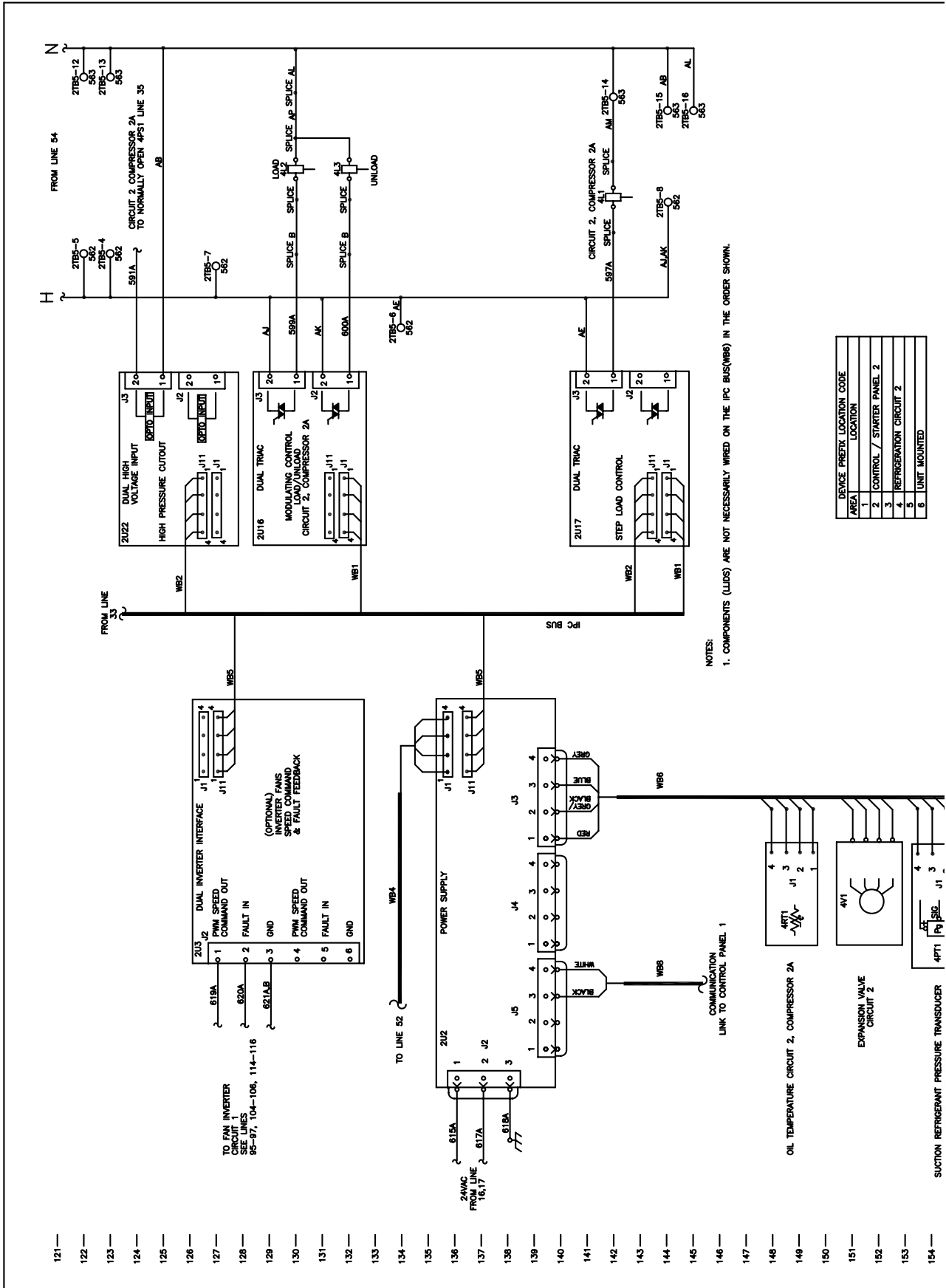


REPLACES 2308-1993	AUTOCAD	2309-4880	SCHEMATIC RTAC LARGE AIR COOLED PANEL 1 CONTROLS THREE OR FOUR COMPRESSORS
REVISION DATE 01-17-02	THE TRANE COMPANY		
DRAWN BY PEL	AMERICAN STANDARD INC.		
DATE 7-21-00	TRANE AIR CONDITIONING DIVISION		
SIMILAR TO			

**CAUTION**  
USE COPPER CONDUCTORS ONLY!  
AUTOMATICALLY ACCEPTED TO ACCEPT  
OTHER TYPES OF CONDUCTORS.  
FAILURE TO DO SO MAY CAUSE DAMAGE TO THE  
EQUIPMENT.

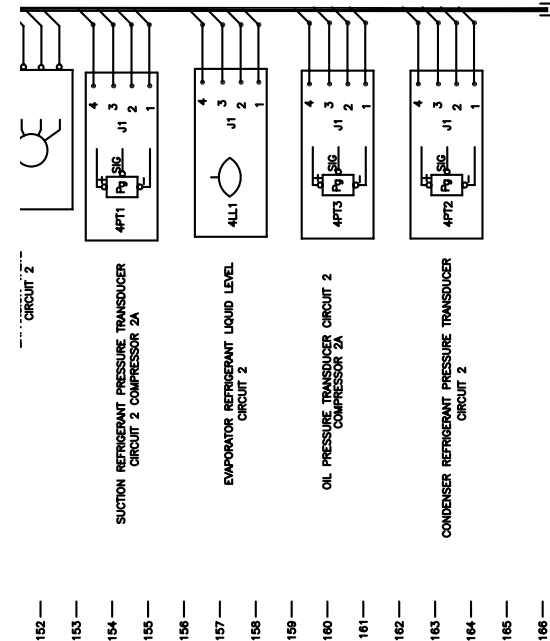
**ATTENTION**  
N'UTILISER QUE DES CONDUCTEURS EN CUIVRE!  
LES BORNES DE L'UNITE NE SONT PAS CONÇUES  
POUR RECEVOIR D'AUTRES TIPIES DE CONDUCTEURS.  
L'UTILISATION D'UN AUTRE CONDUCTEUR PEUT  
ENDOMMAGER L'EQUIPEMENT.

**PRECAUCION**  
¡UTILICE ÚNICAMENTE CONDUCTORES DE COBRE!  
LAS TERMINALES DE LA UNIDAD NO ESTÁN DISEÑADAS  
PARA ACEPTAR OTROS TIPOS DE CONDUCTORES.  
SI NO LO HACE, PUEDE OCASIONAR DAÑO AL EQUIPO.



NOTES:  
 1. COMPONENTS (LIDS) ARE NOT NECESSARILY WIRED ON THE IPC BUS(WB6) IN THE ORDER SHOWN.

AREA	DEVICE PREFIX	LOCATION CODE
1		LOCATION
2		CONTROL / STARTER PANEL 2
3		REFRIGERATION CIRCUIT 2
4		REFRIGERATION CIRCUIT 2
5		REFRIGERATION CIRCUIT 2
6		UNIT MOUNTED



2	CONTROL / STARTER PANEL 2
3	REFRIGERATION CIRCUIT 2
4	REFRIGERATION CIRCUIT 2
5	UNIT MOUNTED
6	UNIT MOUNTED

DEVICE DESIGNATION	LINE NUMBER	LEGEND	DESCRIPTION
<b>RTAC PANEL 1 COMPONENTS, LOCATION 1</b>			
20B1	7		HVAC CIRCUIT BREAKER FOR CUSTOMER WIRING, ELECTRICAL CIRCUIT 2
2F7-12	63-65,90-92		CONDENSER FAN FUSES, CIRCUIT 2
2F13-14	67		CONTROL POWER TRANSFORMER PRIMARY FUSES
2F15	18		CONTROL POWER TRANSFORMER SECONDARY FUSE, 115 VOLTAGE CIRCUIT
2F17-18	100-102,110,112		INVERTER DRIVE FUSES, CIRCUIT 2
2K1	44		START CONTACTOR, COMPRESSOR 2A
2K2	47		YD RUN CONTACTOR, COMPRESSOR 2A
2K3	53		YD TRANSISTOR CONTACTOR, COMPRESSOR 2A
2K4	55		YD TRANSISTOR CONTACTOR, COMPRESSOR 2A
2K13	25		CONDENSER FAN CONTACTOR, CIRCUIT 2
2K14	26		CONDENSER FAN CONTACTOR, CIRCUIT 2
2K15	31		CONDENSER FAN CONTACTOR, CIRCUIT 2
2K16	34		CONDENSER FAN CONTACTOR, CIRCUIT 2
2S91	7		MOLDED CASE SWITCH FOR CUSTOMER POWER WIRING, ELECTRICAL CIRCUIT 2
2T1	14		CONTROL POWER SUPPLY TRANSFORMER
2T2	12		CURRENT TRANSFORMER, COMPRESSOR 2A, LINE A
2T3	13		CURRENT TRANSFORMER, COMPRESSOR 2A, LINE B
2T4	18		CURRENT TRANSFORMER, COMPRESSOR 2A, LINE C
2T10	109		INTERMITTENT DRIVE POWER SUPPLY TRANSFORMER, CIRCUIT 2
2T11	14		TERMINAL BLOCK FOR CUSTOMER POWER WIRING, ELECTRICAL CIRCUIT 2
2T12	12		FACTORY CONTROL WIRING TERMINAL STRIP
2T13	13		FACTORY CONTROL WIRING TERMINAL STRIP
2T14	13		FACTORY CONTROL WIRING TERMINAL STRIP
2T15	135		POWER SUPPLY MODULE, CHSEN 2A, SPEED COMMAND AND FAULT FEEDBACK, CIRCUIT 2
2T16	136		POWER SUPPLY MODULE, CHSEN 2A, SPEED COMMAND AND FAULT FEEDBACK, CIRCUIT 2
2T17	137		STARTER MODULE, COMPRESSOR 2A
2U14	37		QUAD RELAY OUTPUT, FAN CONTROL, CIRCUIT 2
2U15	22		DUAL TRAC OUTPUT, MODULATING LOAD / UNLOAD, COMPRESSOR 2A
2U16	128		DUAL TRAC OUTPUT, STEP LOAD, COMPRESSORS 2A
2U17	140		DUAL TRAC OUTPUT, STEP LOAD, COMPRESSORS 2A
2U22	124		DUAL HV BINARY INPUT, HIGH PRESSURE OUTPUT, COMPRESSORS 2A
<b>RTAC REFRIGERANT COMPONENTS FOR CIRCUIT 2, LOCATION 4</b>			
4B1	15		MOTOR, COMPRESSOR 2A, CIRCUIT 2
4B3-15	69-120		CONDENSER FAN MOTORS, CIRCUIT 2
4H1	21		CONDENSER FAN HEATER, CIRCUIT 2
4H2	22		CONDENSER FAN HEATER, CIRCUIT 2
4L1	142		STEP LOAD CONTROL SOLENOID VALVE, COMPRESSOR 2A
4L2	130		PROPORTIONAL LOAD CONTROL SOLENOID VALVE, COMPRESSOR 2A
4L3	132		PROPORTIONAL UNLOAD CONTROL SOLENOID VALVE, COMPRESSOR 2A
4L11	157		EVAPORATOR REFRIGERANT LIQUID LEVEL SENSOR, CIRCUIT 2
4P1	35		HIGH PRESSURE OUTPUT SWITCH, COMPRESSOR 2A
4P2	164		LOW PRESSURE OUTPUT SWITCH, COMPRESSOR 2A
4P3	163		CONDENSER REFRIGERANT PRESSURE TRANSDUCER, CIRCUIT 2
4P4	180		OIL PRESSURE TRANSDUCER, COMPRESSOR 2A
4P5	180		OIL PRESSURE TRANSDUCER, COMPRESSOR 2A
4P6	90,148		OIL TEMPERATURE SENSOR, DRIVE MOTOR, CIRCUIT 2
4P7	110		TEMPERATURE SENSOR, DRIVE MOTOR, CIRCUIT 2
4V1	151		ELECTRONIC EXPANSION VALVE, CIRCUIT 2

**CAUTION**  
USE COPPER CONDUCTORS ONLY!  
UNIT TERMINALS ARE NOT DESIGNED TO ACCEPT OTHER TYPES OF CONDUCTORS.  
FAILURE TO DO SO MAY CAUSE DAMAGE TO THE EQUIPMENT.

**ATTENTION**  
N'UTILISER QUE DES CONDUCTEURS EN CUIVRE!  
LES BORNES DE L'UNITÉ NE SONT PAS CONÇUES POUR RECEVOIR D'AUTRES TYPES DE CONDUCTEURS.  
L'UTILISATION DE TOUT AUTRE CONDUCTEUR PEUT ENDOMMAGER L'ÉQUIPEMENT.

**PRECAUCIÓN**  
¡UTILICE ÚNICAMENTE CONDUCTORES DE COBRE!  
LAS TERMINALES DE LA UNIDAD NO ESTÁN DISEÑADAS PARA ACEPTAR OTROS TIPOS DE CONDUCTORES.  
SI NO LO HACE, PUEDE OCASIONAR DAÑO AL EQUIPO.

**HAZARDOUS VOLTAGE!**  
DISCONNECT ALL ELECTRIC POWER BEFORE WORKING ON THIS UNIT. LOCK OUT AND TAG OUT BEFORE SERVICING. INSURE THAT ALL MOTOR CAPACITORS ARE FULLY DISCHARGED. VARIABLE SPEED DRIVE, REFER TO DRIVE INSTRUCTIONS FOR CAPACITOR DISCHARGE. FAILURE TO DO THE ABOVE RESULT IN DEATH OR SERIOUS INJURY.

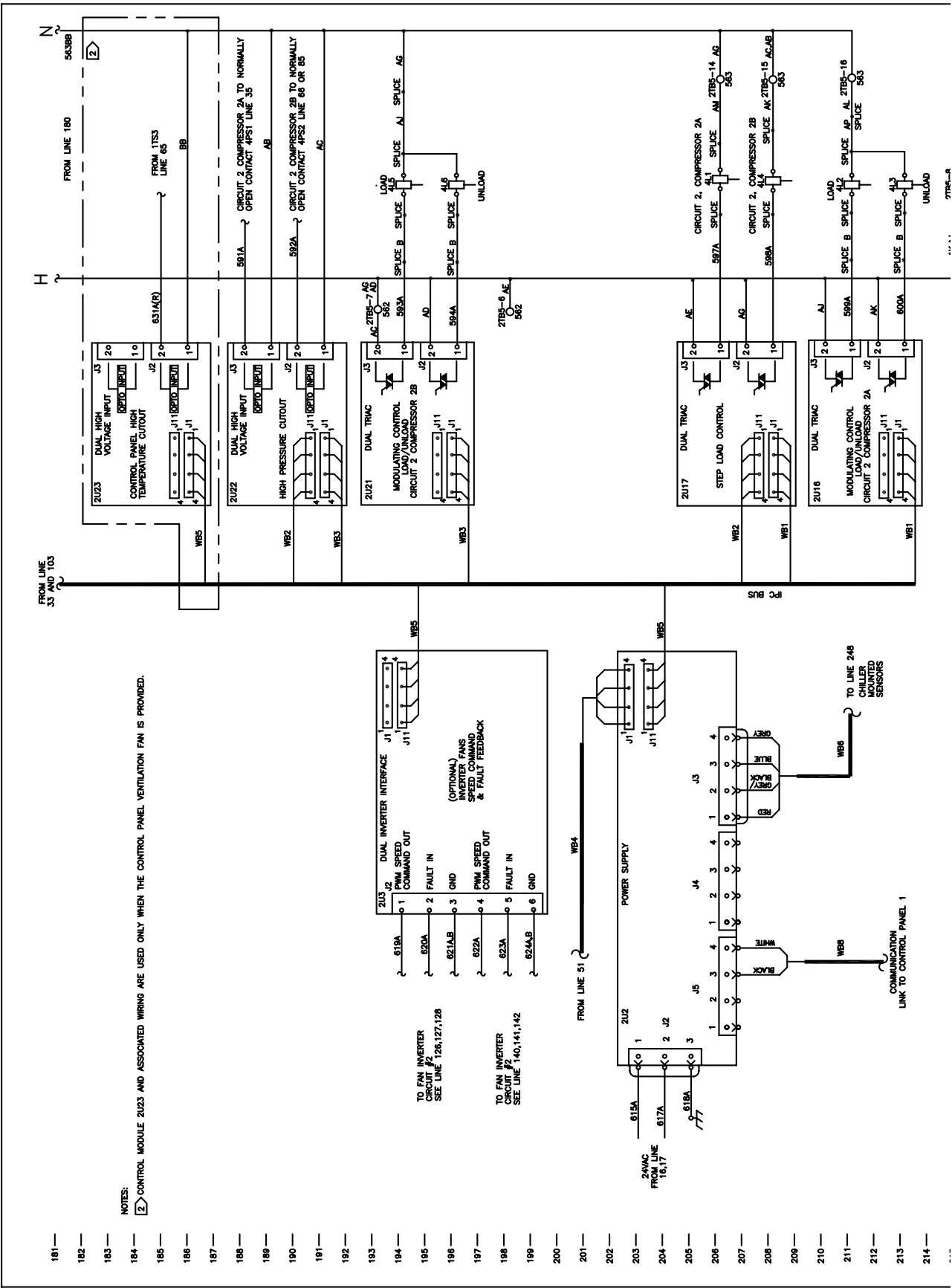
**AVERTISSEMENT**  
TENSION DANGEREUSE!  
COUPER TOUTES LES TENSIONS ET VERROUILLER LES DISPOSITIFS DE VERROUILLAGE ET DES ÉTIQUETTES AVANT TOUTE INTERVENTION. VÉRIFIER QUE TOUTES LES CAPACITÉS DES MOTEURS SONT DÉCHARGÉES. CAS D'UNITÉS À VITESSE VARIABLE, SE REPORTER AUX INSTRUCTIONS DE CONDUCTEURS POUR LE DÉCHARGEMENT DES CONDENSATEURS. NE PAS RESPECTER CES MESURES DE PRÉCAUTION PEUT ENTRAINER DES BLESSURES GRAVES POUVANT ÊTRE MORTELLES.

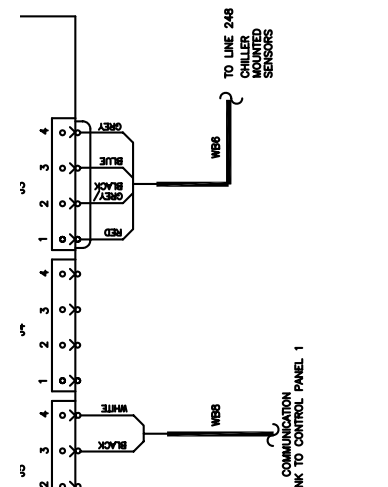
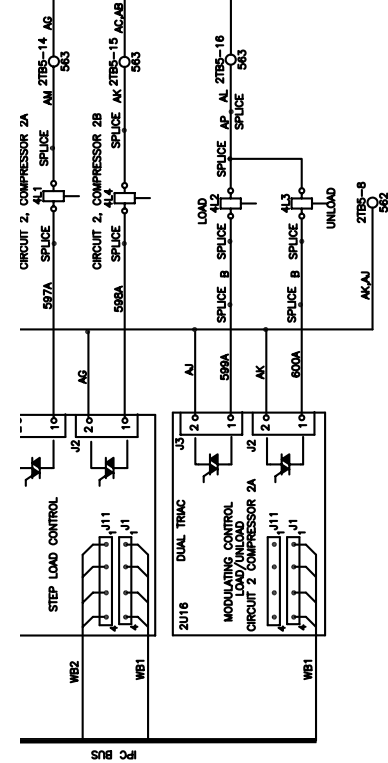
**ADVERTENCIA**  
¡VOLTAJE PELIGROSO!  
DESCONECTE TODA LA ENERGÍA ELÉCTRICA ANTES DE TRABAJAR EN ESTE EQUIPO. SIGA LOS PROCEDIMIENTOS DE CERRAJE Y ETIQUETADO ANTES DE PROCEDER AL SERVICIO. ASEGURESE DE QUE TODOS LOS CONDENSADORES DE LOS MOTORES SEAN DESCARGADOS. EL VOLTAJE VARIABLE PARA LAS UNIDADES CON ELE DE DIRECCIÓN DE VELOCIDAD VARIABLE, CONSULTE LAS INSTRUCCIONES PARA LA DESCARGA DE LAS CAPACITANCIAS. NO REALIZAR LO ANTERIORMENTE INDICADO, PODRÁ OCASIONAR LA MUERTE O SERIAS LESIONES PERSONALES.

REPLACES 2309-1998	AUTOCAD	2309-4882	CD
REVISION DATE 9-27-01	TRIK TRAK COMPANY A DIVISION OF AMERICAN OVERSEAS, INC. 1000 W. BROADWAY, SUITE 100 DALLAS, TEXAS 75201 TEL: 214-761-1000 FAX: 214-761-1001		
DRAWN BY PBL		SCHEMATIC	
DATE 8-1-00	SIMILAR TO	RTAC LARR AIR COOLED CONTROLS/LIQUID BUS PANEL 2 THREE COMPRESSORS	

181 —  
 182 —  
 183 —  
 184 —  
 185 —  
 186 —  
 187 —  
 188 —  
 189 —  
 190 —  
 191 —  
 192 —  
 193 —  
 194 —  
 195 —  
 196 —  
 197 —  
 198 —  
 199 —  
 200 —  
 201 —  
 202 —  
 203 —  
 204 —  
 205 —  
 206 —  
 207 —  
 208 —  
 209 —  
 210 —  
 211 —  
 212 —  
 213 —  
 214 —

NOTES:  
 ② CONTROL MODULE 2U23 AND ASSOCIATED WIRING ARE USED ONLY WHEN THE CONTROL PANEL VENTILATION FAN IS PROVIDED.





777

206 —  
207 —  
208 —  
209 —  
210 —  
211 —  
212 —  
213 —  
214 —  
215 —  
216 —  
217 —  
218 —  
219 —  
220 —  
221 —  
222 —  
223 —  
224 —  
225 —  
226 —  
227 —  
228 —  
229 —  
230 —  
231 —  
232 —  
233 —  
234 —  
235 —  
236 —  
237 —  
238 —  
239 —  
240 —

2309-2206	THE TRANE COMPANY	SCHEMATIC
REVISION DATE	AMERICAN STANDARD INC.	RTAC
9-27-01	REVISION 1	LARGE AIR COOLED
DRAWN BY	PBL	PANEL 2
DATE	7-26-00	FOUR COMPRESSORS
	SIMILAR TO	

**CAUTION**  
USE COPPER CONDUCTORS ONLY!  
UNEQUALS ARE NOT DESIGNED TO ACCEPT OTHER TYPES OF CONDUCTORS.  
FAILURE TO DO SO MAY CAUSE DAMAGE TO THE EQUIPMENT.

**ATTENTION**  
N'UTILISER QUE DES CONDUCTEURS EN CUIVRE!  
LES BORNES DE L'UNITE NE SONT PAS CONÇUES POUR RECEVOIR D'AUTRES TYPES DE CONDUCTEURS.  
L'UTILISATION DE TOUT AUTRE CONDUCTEUR PEUT ENDOMMAGER L'EQUIPEMENT.

**PRECAUCIÓN**  
UTILICE ÚNICAMENTE CONDUCTORES DE COBRE!  
LAS TERMINALES DE LA UNIDAD NO ESTÁN DISEÑADAS PARA ACEPTAR OTROS TIPOS DE CONDUCTORES.  
SI NO LO HACE, PUEDE OCASIONAR DAÑO AL EQUIPO.

**WARNING**  
HAZARDOUS VOLTAGE!  
DISCONNECT ALL ELECTRIC POWER FROM THE UNIT BEFORE SERVICING AND FOLLOW LOCK OUT AND TAG PROCEDURES BEFORE SERVICING. INSURE THAT ALL MOTOR CAPACITORS HAVE DISCHARGED. ALWAYS WEAR YOUR VARIABLE SPEED DRIVE. REFER TO DRIVE INSTRUCTIONS FOR CAPACITOR DISCHARGE. FAILURE TO DO THE ABOVE BEFORE SERVICING COULD RESULT IN DEATH OR SERIOUS INJURY.

**AVERTISSEMENT**  
TENSION DANGEREUSE!  
COUPER LE PUISSANCE ELECTRIQUE DE L'UNITE AVANT LE SERVICE ET SUIVRE LES PROCEDURES DE VERROUILLAGE ET DES ETIQUETTES AVANT TOUTE INTERVENTION. VEILLER QUE TOUS LES CONDENSATEURS DES MOTEURS SONT DECHARGES DANS LE CAS D'UNITES COMPORTANT DES ENTRAINEMENTS A VITESSE VARIABLE. SE REPORTER AUX INSTRUCTIONS DU MANUEL POUR DECHARGER LES CONDENSATEURS. NE PAS RESPECTER CES MESURES DE PRECAUTION PEUT ENTRAÎNER DES BLESSURES GRAVES POUVANT ETRE MORTELLES.

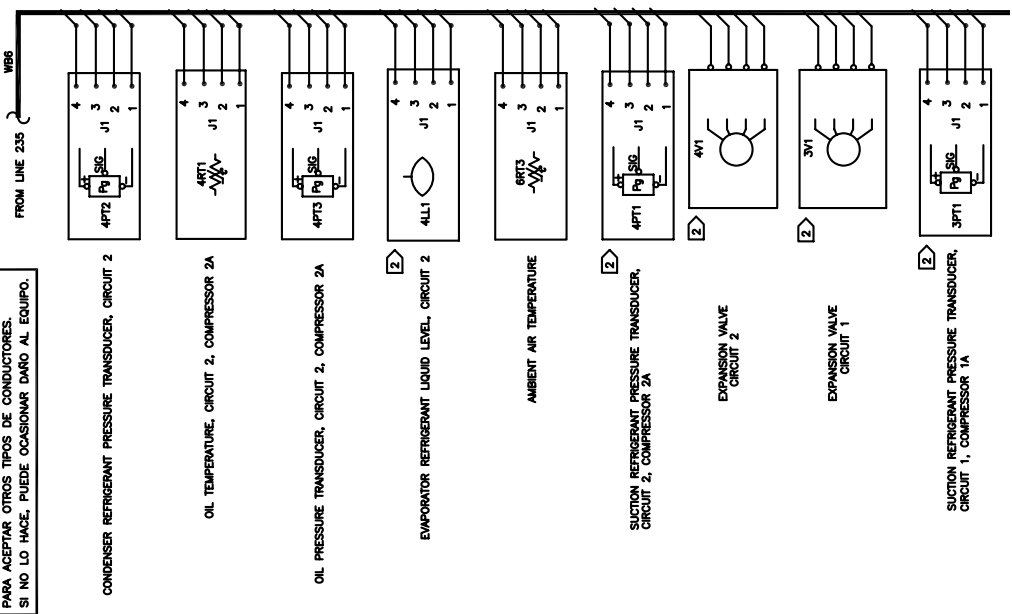
**ADVERTENCIA**  
VOLTAJE PELIGROSO!  
DESCONECTE TODA LA ENERGIA ELECTRICA DE LA UNIDAD ANTES DE SERVICIOS. SIGA LOS PROCEDIMIENTOS DE CIERRE Y ETIQUETADO ANTES DE PROCEDER AL SERVICIO. ASEGURESE DE QUE TODOS LOS CONDENSADORES DE LOS MOTORES SEAN DESCARGADOS EL VOLTAJE ALMACENADO. PARA LAS UNIDADES CON EJE DE DIRECCION DE VELOCIDAD VARIABLE, REFERIRSE A LAS INSTRUCCIONES PARA LA DESCARGA DEL CONDENSADOR. EL NO REALIZAR LO ANTERIORMENTE INDICADO, PODRIA OCASIONAR LA MUERTE O SERIAS LESIONES PERSONALES.

**CAUTION**  
 USE COPPER CONDUCTORS ONLY!  
 UNIT TERMINALS ARE NOT DESIGNED TO ACCEPT  
 OTHER TYPES OF CONDUCTORS.  
 FAILURE TO DO SO MAY CAUSE DAMAGE TO THE  
 EQUIPMENT.

**ATTENTION**  
 N'UTILISER QUE DES CONDUCTEURS EN CUIVRE!  
 LES BORNES D'UNITÉS NE SONT PAS CONÇUES  
 POUR ACCEPTER D'AUTRES TIPOUS DE CONDUCTEURS.  
 L'UTILISATION DE TOUT AUTRE CONDUCTEUR PEUT  
 ENDOMMAGER L'ÉQUIPEMENT.

**PRECAUCIÓN**  
 ¡UTILICE ÚNICAMENTE CONDUCTORES DE COBRE!  
 LAS TERMINALES DE LA UNIDAD NO ESTÁN DISEÑADAS  
 PARA ACEPTAR OTROS TIPOS DE CONDUCTORES.  
 SI NO LO HACE, PUEDE OCASIONAR DAÑO AL EQUIPO.

AREA	LOCATION	DEVICE PREFIX LOCATION CODE
1	CONTROL AND STARTER PANEL	
2	REFRIGERATION CIRCUIT 1	
3	REFRIGERATION CIRCUIT 2	
4	CUSTOMER REMOTELY INSTALLED	
5	CUSTOMER REMOTELY INSTALLED	
6	LIMIT MOUNTED	
7	REMOTE EWP	



DEVICE DESIGNATION	LINE NUMBER	DESCRIPTION
181	21	RTAC PANEL 1 COMPONENTS, LOCATION 1
182	6	MAIN VENTILATION FAN MOTOR, ELECTRICAL CIRCUIT 1
183	6	HACKER CIRCUIT BREAKER FOR CUSTOMER WIRING, ELECTRICAL CIRCUIT 2
184	103-105/108-114	CONDENSER FAN FUSES, CIRCUIT 2
185	103-105/108-114	CONDENSER FAN FUSES, CIRCUIT 1
186	18	CONTROL POWER TRANSFORMER PRIMARY FUSES
187	18	CONTROL POWER TRANSFORMER SECONDARY FUSES
188	18	INVERTER DRIVE FUSES, CIRCUIT 2
189	18	INVERTER DRIVE FUSES, CIRCUIT 1
190	3	START CONTACTOR, COMPRESSOR 1A
191	44	START CONTACTOR, COMPRESSOR 2A
192	47	YD SHORTING CONTACTOR, COMPRESSOR 1A
193	50	YD SHORTING CONTACTOR, COMPRESSOR 2A
194	53	YD TRANSITION CONTACTOR, COMPRESSOR 1A
195	56	YD TRANSITION CONTACTOR, COMPRESSOR 2A
196	106	YD RUN CONTACTOR, COMPRESSOR 1A
197	109	YD RUN CONTACTOR, COMPRESSOR 2A
198	111	YD SHORTING CONTACTOR, COMPRESSOR 2A
199	114	YD TRANSITION CONTACTOR, COMPRESSOR 1A
200	27	YD TRANSITION CONTACTOR, COMPRESSOR 2A
201	30	CONDENSER FAN CONTACTOR, CIRCUIT 1
202	30	CONDENSER FAN CONTACTOR, CIRCUIT 2
203	33	CONDENSER FAN CONTACTOR, CIRCUIT 1
204	33	CONDENSER FAN CONTACTOR, CIRCUIT 2
205	36	CONDENSER FAN CONTACTOR, CIRCUIT 1
206	36	CONDENSER FAN CONTACTOR, CIRCUIT 2
207	88	CONDENSER FAN CONTACTOR, CIRCUIT 1
208	88	CONDENSER FAN CONTACTOR, CIRCUIT 2
209	92	CONDENSER FAN CONTACTOR, CIRCUIT 1
210	92	CONDENSER FAN CONTACTOR, CIRCUIT 2
211	95	CONDENSER FAN CONTACTOR, CIRCUIT 1
212	95	CONDENSER FAN CONTACTOR, CIRCUIT 2
213	6	INCLUDED CASE SWITCH FOR CUSTOMER POWER WIRING, ELECTRICAL CIRCUIT 1
214	6	INCLUDED CASE SWITCH FOR CUSTOMER POWER WIRING, ELECTRICAL CIRCUIT 2
215	6	MOULDED CASE SWITCH FOR CUSTOMER POWER WIRING, ELECTRICAL CIRCUIT 1
216	6	MOULDED CASE SWITCH FOR CUSTOMER POWER WIRING, ELECTRICAL CIRCUIT 2
217	12	CURRENT TRANSFORMER, COMPRESSOR 1A, LINE A
218	12	CURRENT TRANSFORMER, COMPRESSOR 1A, LINE B
219	15	CURRENT TRANSFORMER, COMPRESSOR 1A, LINE C
220	15	CURRENT TRANSFORMER, COMPRESSOR 2A, LINE A
221	15	CURRENT TRANSFORMER, COMPRESSOR 2A, LINE B
222	15	CURRENT TRANSFORMER, COMPRESSOR 2A, LINE C
223	75	POTENTIAL TRANSFORMER, INVERTER DRIVE OVER VOLTAGE
224	43	POTENTIAL TRANSFORMER, INVERTER DRIVE OVER VOLTAGE
225	43	INVERTER DRIVE POWER SUPPLY TRANSFORMER, CIRCUIT 1
226	43	INVERTER DRIVE POWER SUPPLY TRANSFORMER, CIRCUIT 2
227	6	TERMINAL BLOCK FOR CUSTOMER POWER WIRING, ELECTRICAL CIRCUIT 1
228	6	TERMINAL BLOCK FOR CUSTOMER POWER WIRING, ELECTRICAL CIRCUIT 2
229	6	CUSTOMER CONTROL CABLE TERMINAL STRIP
230	6	FACTORY CONTROL WIRING TERMINAL STRIP
231	75	MAXIMUM TEMPERATURE LIMIT SWITCH 1, MAIN CONTROL PANEL
232	21	VENTILATION FAN ON/OFF TEMPERATURE CONTROL SWITCH, MAIN CONTROL PANEL
233	21	VENTILATION FAN ON/OFF TEMPERATURE CONTROL SWITCH, MAIN CONTROL PANEL
234	27	POWER SUPPLY MODULE TRACER VALVE
235	27	DUAL INVERTER INTERFACE, FAN SPEED COMMAND AND FAULT FEEDBACK, CIRCUIT 1 AND 2
236	212	DUAL LV BINARY INPUT, EXTERNAL EMERGENCY STOP AND EXTERNAL AUTO/STOP
237	207	DUAL LV BINARY INPUT, EXTERNAL CIRCUIT LOCKOUT, REFRIGERANT CIRCUIT 1 AND 2
238	207	DUAL LV BINARY INPUT, EXTERNAL CIRCUIT LOCKOUT, REFRIGERANT CIRCUIT 1 AND 2
239	194	DUAL LV BINARY INPUT, ICE MAKING CONTROL
240	188	COM 2 OR COM 5 COMMUNICATION INTERFACE, (EACHELON)
241	240	DUAL RELAY OUTPUT, CHILLED WATER PUMP CONTROL
242	211	DUAL RELAY OUTPUT, CHILLED WATER PUMP CONTROL
243	214	DUAL RELAY OUTPUT, ALARM AND STATUS RELAYS
244	35	DUAL RELAY OUTPUT, ICE MAKING STATUS RELAY
245	35	DUAL RELAY OUTPUT, ICE MAKING STATUS RELAY
246	209	DUAL TRAC OUTPUT, MODULATING LOAD/UNLOAD, COMPRESSOR 1A
247	209	DUAL TRAC OUTPUT, MODULATING LOAD/UNLOAD, COMPRESSOR 1A
248	88	STARTER MODULE, COMPRESSOR 2A, CIRCUIT 1
249	88	STARTER MODULE, COMPRESSOR 2A, CIRCUIT 2
250	83	DUAL TRAC OUTPUT, FAN CONTROL, COMPRESSOR 2A
251	192	DUAL TRAC OUTPUT, MODULATING LOAD/UNLOAD, COMPRESSOR 2A
252	187	DUAL HV BINARY INPUT, HIGH PRESSURE CUTOFF, COMPRESSORS 1A AND 2A
253	182	DUAL HV BINARY INPUT, HIGH PRESSURE CUTOFF, MAIN CONTROL PANEL
254	182	DUAL HV BINARY INPUT, HIGH PRESSURE CUTOFF, MAIN CONTROL PANEL
255	15	RTAC REFRIGERANT COMPONENTS FOR CIRCUIT 1, LOCATION 3
256	122-148	MOTOR, COMPRESSOR 1A, CIRCUIT 1
257	22	CONDENSER FAN MOTORS, CIRCUIT 1
258	22	CONDENSER FAN MOTORS, CIRCUIT 2
259	205	STEP LOAD CONTROL SOLENOID VALVE, COMPRESSOR 1A
260	210	PROPORTIONAL UNLOAD CONTROL SOLENOID VALVE, COMPRESSOR 1A
261	212	PROPORTIONAL UNLOAD CONTROL SOLENOID VALVE, COMPRESSOR 1A
262	288	EVAPORATOR REFRIGERANT LIQUID LEVEL SENSOR, CIRCUIT 1
263	279	EVAPORATOR REFRIGERANT PRESSURE TRANSDUCER, CIRCUIT 1, COMPRESSOR 1A
264	291	CONDENSER REFRIGERANT PRESSURE TRANSDUCER, CIRCUIT 1
265	291	CONDENSER REFRIGERANT PRESSURE TRANSDUCER, CIRCUIT 1
266	36	OIL PRESSURE TRANSDUCER, COMPRESSOR 1A
267	36	OIL PRESSURE TRANSDUCER, COMPRESSOR 1A
268	36	HIGH PRESSURE CUTOFF SWITCH, COMPRESSOR 1A
269	36	HIGH PRESSURE CUTOFF SWITCH, COMPRESSOR 1A
270	122,301,310,322	CONDENSER FAN INVERTER DRIVE, CIRCUIT 1
271	276	ELECTRONIC EXPANSION VALVE, CIRCUIT 1
272	75	RTAC REFRIGERANT COMPONENTS FOR CIRCUIT 2, LOCATION 4
273	152-179	MOTOR, COMPRESSOR 2A, CIRCUIT 2
274	83	CONDENSER FAN MOTORS, CIRCUIT 2
275	83	CONDENSER FAN MOTORS, CIRCUIT 2
276	207	STEP LOAD CONTROL SOLENOID VALVE, COMPRESSOR 2A
277	193	PROPORTIONAL UNLOAD CONTROL SOLENOID VALVE, COMPRESSOR 2A
278	195	PROPORTIONAL UNLOAD CONTROL SOLENOID VALVE, COMPRESSOR 2A
279	264	EVAPORATOR REFRIGERANT LIQUID LEVEL SENSOR, CIRCUIT 2
280	264	EVAPORATOR REFRIGERANT LIQUID LEVEL SENSOR, CIRCUIT 2
281	483-4816	SUCTION REFRIGERANT PRESSURE TRANSDUCER, CIRCUIT 2, COMPRESSOR 2A
282	4816	SUCTION REFRIGERANT PRESSURE TRANSDUCER, CIRCUIT 2, COMPRESSOR 2A
283	412	STEP LOAD CONTROL SOLENOID VALVE, COMPRESSOR 2A
284	412	PROPORTIONAL UNLOAD CONTROL SOLENOID VALVE, COMPRESSOR 2A
285	412	PROPORTIONAL UNLOAD CONTROL SOLENOID VALVE, COMPRESSOR 2A
286	412	PROPORTIONAL UNLOAD CONTROL SOLENOID VALVE, COMPRESSOR 2A
287	412	PROPORTIONAL UNLOAD CONTROL SOLENOID VALVE, COMPRESSOR 2A
288	412	PROPORTIONAL UNLOAD CONTROL SOLENOID VALVE, COMPRESSOR 2A
289	412	PROPORTIONAL UNLOAD CONTROL SOLENOID VALVE, COMPRESSOR 2A
290	412	PROPORTIONAL UNLOAD CONTROL SOLENOID VALVE, COMPRESSOR 2A
291	412	PROPORTIONAL UNLOAD CONTROL SOLENOID VALVE, COMPRESSOR 2A
292	412	PROPORTIONAL UNLOAD CONTROL SOLENOID VALVE, COMPRESSOR 2A
293	412	PROPORTIONAL UNLOAD CONTROL SOLENOID VALVE, COMPRESSOR 2A
294	412	PROPORTIONAL UNLOAD CONTROL SOLENOID VALVE, COMPRESSOR 2A
295	412	PROPORTIONAL UNLOAD CONTROL SOLENOID VALVE, COMPRESSOR 2A
296	412	PROPORTIONAL UNLOAD CONTROL SOLENOID VALVE, COMPRESSOR 2A
297	412	PROPORTIONAL UNLOAD CONTROL SOLENOID VALVE, COMPRESSOR 2A
298	412	PROPORTIONAL UNLOAD CONTROL SOLENOID VALVE, COMPRESSOR 2A
299	412	PROPORTIONAL UNLOAD CONTROL SOLENOID VALVE, COMPRESSOR 2A
300	412	PROPORTIONAL UNLOAD CONTROL SOLENOID VALVE, COMPRESSOR 2A
301	412	PROPORTIONAL UNLOAD CONTROL SOLENOID VALVE, COMPRESSOR 2A
302	412	PROPORTIONAL UNLOAD CONTROL SOLENOID VALVE, COMPRESSOR 2A
303	412	PROPORTIONAL UNLOAD CONTROL SOLENOID VALVE, COMPRESSOR 2A
304	412	PROPORTIONAL UNLOAD CONTROL SOLENOID VALVE, COMPRESSOR 2A
305	412	PROPORTIONAL UNLOAD CONTROL SOLENOID VALVE, COMPRESSOR 2A
306	412	PROPORTIONAL UNLOAD CONTROL SOLENOID VALVE, COMPRESSOR 2A
307	412	PROPORTIONAL UNLOAD CONTROL SOLENOID VALVE, COMPRESSOR 2A
308	412	PROPORTIONAL UNLOAD CONTROL SOLENOID VALVE, COMPRESSOR 2A
309	412	PROPORTIONAL UNLOAD CONTROL SOLENOID VALVE, COMPRESSOR 2A
310	412	PROPORTIONAL UNLOAD CONTROL SOLENOID VALVE, COMPRESSOR 2A
311	412	PROPORTIONAL UNLOAD CONTROL SOLENOID VALVE, COMPRESSOR 2A
312	412	PROPORTIONAL UNLOAD CONTROL SOLENOID VALVE, COMPRESSOR 2A
313	412	PROPORTIONAL UNLOAD CONTROL SOLENOID VALVE, COMPRESSOR 2A
314	412	PROPORTIONAL UNLOAD CONTROL SOLENOID VALVE, COMPRESSOR 2A
315	412	PROPORTIONAL UNLOAD CONTROL SOLENOID VALVE, COMPRESSOR 2A
316	412	PROPORTIONAL UNLOAD CONTROL SOLENOID VALVE, COMPRESSOR 2A
317	412	PROPORTIONAL UNLOAD CONTROL SOLENOID VALVE, COMPRESSOR 2A
318	412	PROPORTIONAL UNLOAD CONTROL SOLENOID VALVE, COMPRESSOR 2A
319	412	PROPORTIONAL UNLOAD CONTROL SOLENOID VALVE, COMPRESSOR 2A
320	412	PROPORTIONAL UNLOAD CONTROL SOLENOID VALVE, COMPRESSOR 2A
321	412	PROPORTIONAL UNLOAD CONTROL SOLENOID VALVE, COMPRESSOR 2A
322	412	PROPORTIONAL UNLOAD CONTROL SOLENOID VALVE, COMPRESSOR 2A
323	412	PROPORTIONAL UNLOAD CONTROL SOLENOID VALVE, COMPRESSOR 2A
324	412	PROPORTIONAL UNLOAD CONTROL SOLENOID VALVE, COMPRESSOR 2A
325	412	PROPORTIONAL UNLOAD CONTROL SOLENOID VALVE, COMPRESSOR 2A
326	412	PROPORTIONAL UNLOAD CONTROL SOLENOID VALVE, COMPRESSOR 2A
327	412	PROPORTIONAL UNLOAD CONTROL SOLENOID VALVE, COMPRESSOR 2A
328	412	PROPORTIONAL UNLOAD CONTROL SOLENOID VALVE, COMPRESSOR 2A
329	412	PROPORTIONAL UNLOAD CONTROL SOLENOID VALVE, COMPRESSOR 2A
330	412	PROPORTIONAL UNLOAD CONTROL SOLENOID VALVE, COMPRESSOR 2A
331	412	PROPORTIONAL UNLOAD CONTROL SOLENOID VALVE, COMPRESSOR 2A
332	412	PROPORTIONAL UNLOAD CONTROL SOLENOID VALVE, COMPRESSOR 2A
333	412	PROPORTIONAL UNLOAD CONTROL SOLENOID VALVE, COMPRESSOR 2A
334	412	PROPORTIONAL UNLOAD CONTROL SOLENOID VALVE, COMPRESSOR 2A
335	412	PROPORTIONAL UNLOAD CONTROL SOLENOID VALVE, COMPRESSOR 2A
336	412	PROPORTIONAL UNLOAD CONTROL SOLENOID VALVE, COMPRESSOR 2A
337	412	PROPORTIONAL UNLOAD CONTROL SOLENOID VALVE, COMPRESSOR 2A
338	412	PROPORTIONAL UNLOAD CONTROL SOLENOID VALVE, COMPRESSOR 2A
339	412	PROPORTIONAL UNLOAD CONTROL SOLENOID VALVE, COMPRESSOR 2A
340	412	PROPORTIONAL UNLOAD CONTROL SOLENOID VALVE, COMPRESSOR 2A
341	412	PROPORTIONAL UNLOAD CONTROL SOLENOID VALVE, COMPRESSOR 2A
342	412	PROPORTIONAL UNLOAD CONTROL SOLENOID VALVE, COMPRESSOR 2A
343	412	PROPORTIONAL UNLOAD CONTROL SOLENOID VALVE, COMPRESSOR 2A
344	412	PROPORTIONAL UNLOAD CONTROL SOLENOID VALVE, COMPRESSOR 2A
345	412	PROPORTIONAL UNLOAD CONTROL SOLENOID VALVE, COMPRESSOR 2A
346	412	PROPORTIONAL UNLOAD CONTROL SOLENOID VALVE, COMPRESSOR 2A
347	412	PROPORTIONAL UNLOAD CONTROL SOLENOID VALVE, COMPRESSOR 2A
348	412	PROPORTIONAL UNLOAD CONTROL SOLENOID VALVE, COMPRESSOR 2A
349	412	PROPORTIONAL UNLOAD CONTROL SOLENOID VALVE, COMPRESSOR 2A
350	412	PROPORTIONAL UNLOAD CONTROL SOLENOID VALVE, COMPRESSOR 2A
351	412	PROPORTIONAL UNLOAD CONTROL SOLENOID VALVE, COMPRESSOR 2A
352	412	PROPORTIONAL UNLOAD CONTROL SOLENOID VALVE, COMPRESSOR 2A
353	412	PROPORTIONAL UNLOAD CONTROL SOLENOID VALVE, COMPRESSOR 2A
354	412	PROPORTIONAL UNLOAD CONTROL SOLENOID VALVE, COMPRESSOR 2A
355	412	PROPORTIONAL UNLOAD CONTROL SOLENOID VALVE, COMPRESSOR 2A
356	412	PROPORTIONAL UNLOAD CONTROL SOLENOID VALVE, COMPRESSOR 2A
357	412	PROPORTIONAL UNLOAD CONTROL SOLENOID VALVE, COMPRESSOR 2A
358	412	PROPORTIONAL UNLOAD CONTROL SOLENOID VALVE, COMPRESSOR 2A
359	412	PROPORTIONAL UNLOAD CONTROL SOLENOID VALVE, COMPRESSOR 2A
360	412	PROPORTIONAL UNLOAD CONTROL SOLENOID VALVE, COMPRESSOR 2A
361	412	PROPORTIONAL UNLOAD CONTROL SOLENOID VALVE, COMPRESSOR 2A
362	412	PROPORTIONAL UNLOAD CONTROL SOLENOID VALVE, COMPRESSOR 2A
363	412	PROPORTIONAL UNLOAD CONTROL SOLENOID VALVE, COMPRESSOR 2A
364	412	PROPORTIONAL UNLOAD CONTROL SOLENOID VALVE, COMPRESSOR 2A
365	412	PROPORTIONAL UNLOAD CONTROL SOLENOID VALVE, COMPRESSOR 2A
366	412	PROPORTIONAL UNLOAD CONTROL SOLENOID VALVE, COMPRESSOR 2A
367	412	PROPORTIONAL UNLOAD CONTROL SOLENOID VALVE, COMPRESSOR 2A
368	412	PROPORTIONAL UNLOAD CONTROL SOLENOID VALVE, COMPRESSOR 2A
369	412	PROPORTIONAL UNLOAD CONTROL SOLENOID VALVE, COMPRESSOR 2A
370	412	PROPORTIONAL UNLOAD CONTROL SOLENOID VALVE, COMPRESSOR 2A
371	412	PROPORTIONAL UNLOAD CONTROL SOLENOID VALVE, COMPRESSOR 2A
372	412	PROPORTIONAL UNLOAD CONTROL SOLENOID VALVE, COMPRESSOR 2A
373	412	PROPORTIONAL UNLOAD CONTROL SOLENOID VALVE, COMPRESSOR 2A
374	412	PROPORTIONAL UNLOAD CONTROL SOLENOID VALVE, COMPRESSOR 2A
375	412	PROPORTIONAL UNLOAD CONTROL SOLENOID VALVE, COMPRESSOR 2A
376	412	PROPORTIONAL UNLOAD CONTROL SOLENOID VALVE, COMPRESSOR 2A
377	412	PROPORTIONAL UNLOAD CONTROL SOLENOID VALVE, COMPRESSOR 2A
378	412	PROPORTIONAL UNLOAD CONTROL SOLENOID VALVE, COMPRESSOR 2A
379	412	PROPORTIONAL UNLOAD CONTROL SOLENOID VALVE, COMPRESSOR 2A
380	412	PROPORTIONAL UNLOAD CONTROL SOLENOID VALVE, COMPRESSOR 2A

CONDENSER REFRIGERANT PRESSURE TRANSDUCER, CIRCUIT 2

OIL TEMPERATURE, CIRCUIT 2, COMPRESSOR 2A

OIL PRESSURE TRANSDUCER, CIRCUIT 2, COMPRESSOR 2A

EVAPORATOR REFRIGERANT LIQUID LEVEL, CIRCUIT 2

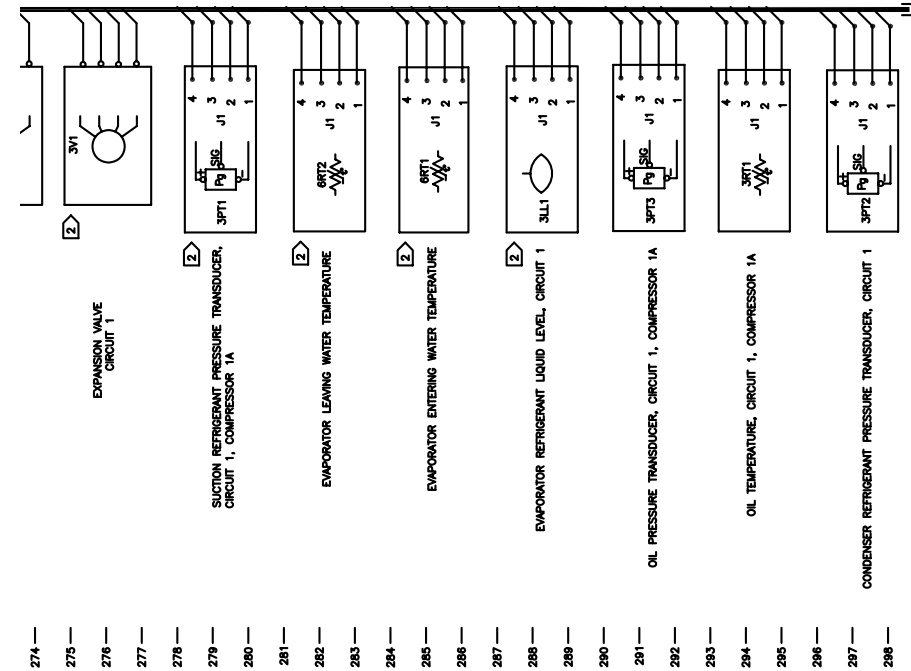
AMBIENT AIR TEMPERATURE

SUCTION REFRIGERANT PRESSURE TRANSDUCER, CIRCUIT 2, COMPRESSOR 2A

EXPANSION VALVE - CIRCUIT 2

EXPANSION VALVE - CIRCUIT 1

SUCTION REFRIGERANT PRESSURE TRANSDUCER, CIRCUIT 1, COMPRESSOR 1A



**NOTE**

1. COMPONENTS (LIDS) ARE NOT NECESSARILY WIRED ON THE IPC BUS(WB6) IN THE ORDER SHOWN.

2. ON PRODUCTS WITH THE REMOTE EVAPORATOR OPTION, THE FOLLOWING CONTROLS ARE LOCATED WITH THE REMOTE EVAPORATOR: 4L1, 4P11, 4P1, 3V1, 3P11, 8R11, 8R2, AND 3L11.

3. DEVICES 1F17-19, 1F20-22, 1T10 & 1T11 ARE ON MULTIPLE LINES ON DRG 2309-2243

3P11 3P12 3P13 3P14 3P15 3P16 3P17 3P18 3P19 3P20 3P21 3P22 3P23 3P24 3P25 3P26 3P27 3P28 3P29 3P30 3P31 3P32 3P33 3P34 3P35 3P36 3P37 3P38 3P39 3P40 3P41 3P42 3P43 3P44 3P45 3P46 3P47 3P48 3P49 3P50 3P51 3P52 3P53 3P54 3P55 3P56 3P57 3P58 3P59 3P60 3P61 3P62 3P63 3P64 3P65 3P66 3P67 3P68 3P69 3P70 3P71 3P72 3P73 3P74 3P75 3P76 3P77 3P78 3P79 3P80 3P81 3P82 3P83 3P84 3P85 3P86 3P87 3P88 3P89 3P90 3P91 3P92 3P93 3P94 3P95 3P96 3P97 3P98 3P99 3P100	279 280 281 282 283 284 285 286 287 288 289 290 291 292 293 294 295 296 297 298 299 300	<p>SUCTION REFRIGERANT PRESSURE TRANSDUCER, CIRCUIT 1, COMPRESSOR 1A CONDENSER REFRIGERANT PRESSURE TRANSDUCER, CIRCUIT 1 HIGH PRESSURE CUTOUT SWITCH, COMPRESSOR 1A OIL TEMPERATURE SENSOR, CIRCUIT 1, COMPRESSOR 1A CONDENSER FAN INVERTER DRIVE, CIRCUIT 1 ELECTRONIC EXPANSION VALVE, CIRCUIT 1</p> <p>RTAC REFRIGERANT COMPONENTS FOR CIRCUIT 2, LOCATION 4 MOTOR COMPRESSOR 2A, CIRCUIT 2 CONDENSER FAN MOTOR, CIRCUIT 2 COMPRESSOR HEATER, CIRCUIT 2 OIL SEPARATOR HEATER, CIRCUIT 2 PROPORTIONAL UNLOAD CONTROL SOLENOID VALVE, COMPRESSOR 2A PROPORTIONAL UNLOAD CONTROL SOLENOID VALVE, COMPRESSOR 2A EVAPORATOR REFRIGERANT LIQUID LEVEL SENSOR, CIRCUIT 2, COMPRESSOR 2A SUCTION REFRIGERANT PRESSURE TRANSDUCER, CIRCUIT 2, COMPRESSOR 2A CONDENSER REFRIGERANT PRESSURE TRANSDUCER, CIRCUIT 2 OIL PRESSURE TRANSDUCER, COMPRESSOR 2A OIL TEMPERATURE SENSOR, CIRCUIT 2, COMPRESSOR 2A TERMINAL STRIP FOR CONDENSER FAN FACTORY WIRING CONDENSER FAN INVERTER DRIVE, CIRCUIT 2 ELECTRONIC EXPANSION VALVE, CIRCUIT 2</p> <p>RTAC CUSTOMER SUPPLIED COMPONENTS, LOCATION 5 CHILLER WATER PUMP MOTOR UNIT STATUS RELAY, (PROGRAMMABLE) DEFAULT IS UNIT ALARM UNIT STATUS RELAY, (PROGRAMMABLE) DEFAULT IS UNIT ALARM UNIT STATUS RELAY, (PROGRAMMABLE) DEFAULT IS UNIT RUNNING UNIT STATUS RELAY, (PROGRAMMABLE) DEFAULT IS UNIT RUNNING UNIT STATUS RELAY, (PROGRAMMABLE) DEFAULT IS MAXIMUM UNIT CAPACITY UNIT STATUS RELAY, (PROGRAMMABLE) DEFAULT IS MAXIMUM UNIT CAPACITY UNIT STATUS RELAY, (PROGRAMMABLE) DEFAULT IS LIMITED UNIT OPERATION UNIT STATUS RELAY, (PROGRAMMABLE) DEFAULT IS LIMITED UNIT OPERATION EXTERNAL EMERGENCY STOP INPUT RELAY EXTERNAL AUTO / STOP INPUT RELAY EXTERNAL LOCKOUT INPUT RELAY FOR REFRIGERANT CIRCUIT 1 EXTERNAL INPUT RELAY TO ENABLE ICE MAKING ICE MAKING STATUS OUTPUT CHILLER WATER FLOW SWITCH</p> <p>RTAC UNIT MOUNTED COMMON COMPONENTS, LOCATION 6 CUSTOMER CONVENIENCE OUTLET (OPTIONAL) EVAPORATOR WATER HEATER (OPTIONAL) EVAPORATOR LEAVING WATER TEMPERATURE SENSOR AMBIENT AIR TEMPERATURE SENSOR TEMPERATURE CONTROL FOR EVAPORATOR WATER HEATER (OPTIONAL) EAST VIEW OR DNA VIEW DISPLAY AND INTERFACE</p> <p>RTAC REMOTE EVAP. MOUNTED COMPONENTS, LOCATION 7 POWER SUPPLY MODULE REMOTE EWP DUAL RELAY EVAPORATOR OIL RETURN CONTROL MODULE, CIRCUIT 1 AND 2 EVAPORATOR OIL RETURN SOLENOID VALVE CKT 1 24V TRANSFORMER EVAPORATOR REFRIGERANT LIQUID LEVEL SENSOR CKT 1 SUCTION REFRIGERANT PRESSURE TRANSDUCER CKT 1 SUCTION REFRIGERANT PRESSURE TRANSDUCER CKT 2 SUCTION REFRIGERANT PRESSURE TRANSDUCER CKT 2 EVAPORATOR LEAVING WATER TEMPERATURE SENSOR EXPANSION VALVE CKT 1 EXPANSION VALVE CKT 2 TERMINAL STRIP</p>
---	--	--

**WARNING**

HAZARDOUS VOLTAGE!  
DISCONNECT ALL ELECTRICAL POWER INCLUDING REMOTE DISCONNECTS FOLLOWING BEFORE ANY SERVICING. INSURE THAT ALL MOTOR CAPACITORS HAVE DISCHARGED STORED VOLTAGE. UNITS WITH CAPACITORS MUST BE LEFT TO DRIVE INSTRUCTIONS FOR CAPACITOR DISCHARGE. FAILURE TO DO THE ABOVE BEFORE SERVICING COULD RESULT IN DEATH OR SERIOUS INJURY.

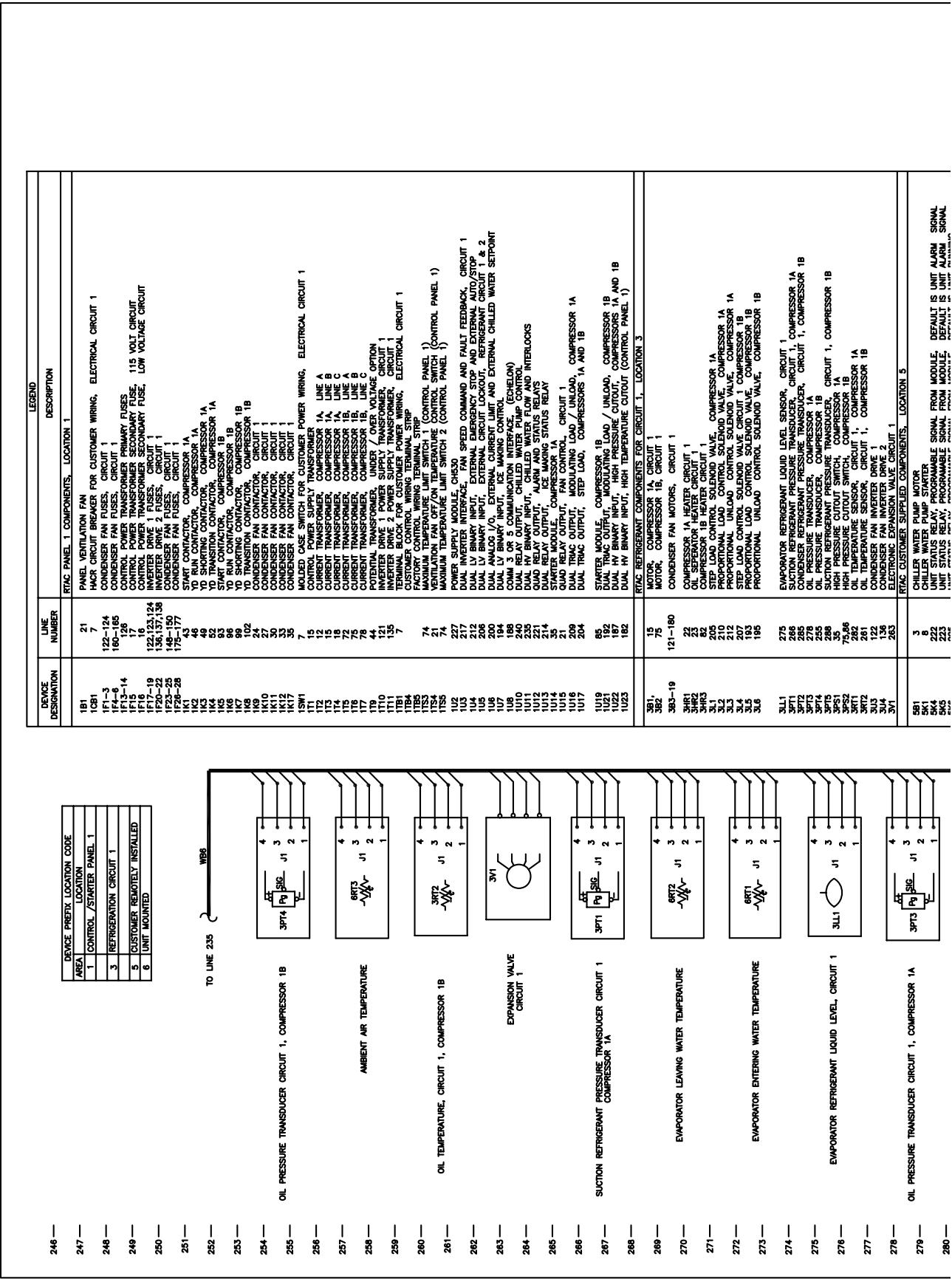
**AVERTISSEMENT**

TENSION DANGEREUSE!  
COUPER TOUTES LES TENSIONS ET OUVRIER LES SECTIONNEURS A DISTANCE, Y COMPRIS LES SECTIONNEURS REMOTES, AVANT DE COMMENCER LE SERVICE. ASSUREZ-VOUS DE QUE TOUS LES CAPACITORS DEL MOTOR HAYAN DESCARGADO EL VOLTAJE ALI CEMADO. LAS UNIDADES CON CAPACITORES DEBE DEJAR EN MARCHA LAS INSTRUCCIONES PARA LA DESCARGA DE LOS CAPACITORES. EL NO REALIZAR LO ANTERIORMENTE PODRIA RESULTAR EN LA MUERTE O SERIAS LESIONES PERSONALES.

**ADVERTENCIA**

VOLTAJE PELIGROSO!  
DESCONECTE TODA LA ENERGIA ELECTRICA INCLUIDO LAS DESCONECCIONES REMOTAS Y LOS SECCIONNEURS REMOTES ANTES DE COMENZAR EL SERVICIO. ASEGURESE DE QUE TODOS LOS CAPACITORES DEL MOTOR HAYAN DESCARGADO EL VOLTAJE ALI CEMADO. LAS UNIDADES CON CAPACITORES DEBE DEJAR EN MARCHA LAS INSTRUCCIONES PARA LA DESCARGA DE LOS CAPACITORES. EL NO REALIZAR LO ANTERIORMENTE PODRIA RESULTAR EN LA MUERTE O SERIAS LESIONES PERSONALES.

REPLACES 2309-2233	AUTOCAD THE TRANE COMPANY A DIVISION OF AMERICAN OVERSEAS AIR-CONDITIONING INC. THE TRANE COMPANY 2100 W. MICHIGAN AVE. GRAND RAPIDS, MI 49508 U.S.A.	2309-1353	REV 001
REVISION DATE		SCHMATIC	
DRAWN BY PBL		RTAC 2 COMPRESSOR MEDIUM/LARGE AIR COOLED	
DATE 12-04-01	SIMILAR TO	LEGEND/LID BUS	

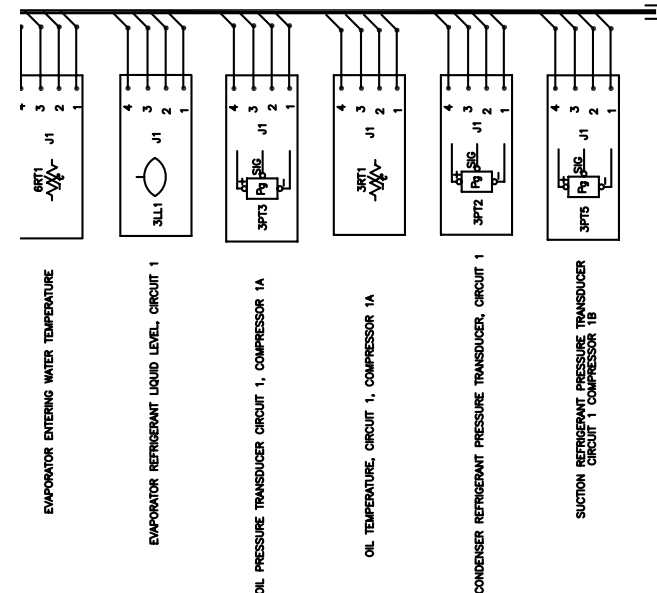


LINE NUMBER	DEVICE DESIGNATION	LEGEND DESCRIPTION
21	181	PANEL VENTILATION FAN
7	1081	HACR CIRCUIT BREAKER FOR CUSTOMER WIRING, ELECTRICAL CIRCUIT 1
122-124	1F1-3	CONDENSER FAN FUSES, CIRCUIT 1
160-165	1F4-614	CONTROL POWER TRANSFORMER PRIMARY FUSES
126	1F5	CONTROL POWER TRANSFORMER SECONDARY FUSE, 115 VOLT CIRCUIT
16	1F16	CONTROL POWER TRANSFORMER SECONDARY FUSE, LOW VOLTAGE CIRCUIT
122,123,124	1F17-19	INVERTER DRIVE 1 FUSES, CIRCUIT 1
136,137,138	1F20-22	INVERTER DRIVE 2 FUSES, CIRCUIT 1
172-175	1F23-26	CONDENSER FAN FUSES, CIRCUIT 1
43	1K1	START CONTACTOR, COMPRESSOR 1A
48	1K2	TO RUN CONTACTOR, COMPRESSOR 1A
52	1K3	TO TRANSITION CONTACTOR, COMPRESSOR 1A
53	1K4	START CONTACTOR, COMPRESSOR 1B
58	1K5	TO RUN CONTACTOR, COMPRESSOR 1B
68	1K6	TO TRANSITION CONTACTOR, COMPRESSOR 1B
102	1K8	CONDENSER FAN CONTACTOR, CIRCUIT 1
24	1K9	CONDENSER FAN CONTACTOR, CIRCUIT 1
37	1K10	CONDENSER FAN CONTACTOR, CIRCUIT 1
30	1K11	CONDENSER FAN CONTACTOR, CIRCUIT 1
33	1K12	CONDENSER FAN CONTACTOR, CIRCUIT 1
35	1K17	CONDENSER FAN CONTACTOR, CIRCUIT 1
7	1S1	MOLDED CASE SWITCH FOR CUSTOMER POWER WIRING, ELECTRICAL CIRCUIT 1
2	1S2	TRANSFORMER, COMPRESSOR 1A
12	1S3	TRANSFORMER, COMPRESSOR 1A, LINE A
15	1S4	CURRENT TRANSFORMER, COMPRESSOR 1A, LINE B
19	1S5	CURRENT TRANSFORMER, COMPRESSOR 1A, LINE C
23	1S6	CURRENT TRANSFORMER, COMPRESSOR 1B, LINE A
75	1S7	CURRENT TRANSFORMER, COMPRESSOR 1B, LINE B
78	1S8	CURRENT TRANSFORMER, COMPRESSOR 1B, LINE C
44	1S9	POTENTIAL TRANSFORMER, UNDER / OVER VOLTAGE OPTION
19	1S10	POTENTIAL TRANSFORMER, UNDER / OVER VOLTAGE OPTION
111	1S11	INVERTER DRIVE 2 POWER SUPPLY TRANSFORMER, CIRCUIT 1
135	1S12	INVERTER DRIVE 1 POWER SUPPLY TRANSFORMER, CIRCUIT 1
7	1S13	TERMINAL BLOCK FOR CUSTOMER POWER WIRING, ELECTRICAL CIRCUIT 1
74	1T1	MAXIMUM TEMPERATURE LIMIT SWITCH 1 (CONTROL PANEL 1)
21	1T2	VENTILATION FAN ON/OFF TEMPERATURE CONTROL SWITCH (CONTROL PANEL 1)
74	1T3	MAXIMUM TEMPERATURE LIMIT SWITCH 2 (CONTROL PANEL 1)
277	1U1	POWER SUPPLY MODULE, CHES3
277	1U2	POWER SUPPLY MODULE, CHES3
212	1U3	DUAL LV BINARY INPUT, EXTERNAL EMERGENCY STOP AND EXTERNAL AUTO/STOP
206	1U4	DUAL LV BINARY INPUT, EXTERNAL CIRCUIT LOCKOUT, REFRIGERANT CIRCUIT 1 & 2
200	1U5	DUAL ANALOG I/O, EXTERNAL CURRENT LIMIT AND EXTERNAL CHILLED WATER SETPOINT
200	1U6	COMM 3 OR 4 COMMUNICATION INTERFACE (TECHNOL)
184	1U7	DUAL RELAY OUTPUT, CHILLED WATER PUMP CONTROL
240	1U8	DUAL HV BINARY INPUT, CHILLED WATER FLOW AND INTERLOCKS
235	1U9	DUAL RELAY OUTPUT, ALICE MANN STATUS RELAYS
211	1U10	DUAL RELAY OUTPUT, ALICE MANN STATUS RELAY
35	1U11	STARTER MODULE, COMPRESSOR 1A
21	1U12	QUAD RELAY OUTPUT, FAN CONTROL, CIRCUIT 1
29	1U13	QUAD RELAY OUTPUT, MODULATING LOAD / UNLOAD, COMPRESSOR 1A
209	1U14	DUAL TRAC OUTPUT, STEP LOAD, COMPRESSORS 1A AND 1B
204	1U15	DUAL TRAC OUTPUT, STEP LOAD, COMPRESSORS 1A AND 1B
65	1U16	STARTER MODULE, COMPRESSOR 1B
187	1U17	DUAL HV BINARY INPUT, HIGH PRESSURE CUTOFF, COMPRESSORS 1A AND 1B
187	1U18	DUAL HV BINARY INPUT, HIGH PRESSURE CUTOFF, COMPRESSORS 1A AND 1B
182	1U19	DUAL HV BINARY INPUT, HIGH TEMPERATURE CUTOFF (CONTROL PANEL 1)
15	381	ETAC REFRIGERANT COMPONENTS FOR CIRCUIT 1, LOCATION 3
75	382	MOTOR, COMPRESSOR 1A, CIRCUIT 1
121-180	383-19	MOTOR, COMPRESSOR 1B, CIRCUIT 1
23	34R1	CONDENSER FAN MOTORS, CIRCUIT 1
82	34R2	CONDENSER FAN MOTORS, CIRCUIT 1
210	34R3	OIL SEPARATOR HEATER CIRCUIT 1
212	34R4	OIL SEPARATOR HEATER CIRCUIT 1
212	34R5	PROPORTIONAL UNLOAD CONTROL SOLENOID VALVE, COMPRESSOR 1A
207	34R6	PROPORTIONAL UNLOAD CONTROL SOLENOID VALVE, COMPRESSOR 1A
212	34R7	STEP LOAD CONTROL SOLENOID VALVE, CIRCUIT 1, COMPRESSOR 1B
34	34R8	STEP LOAD CONTROL SOLENOID VALVE, CIRCUIT 1, COMPRESSOR 1B
185	34R9	PROPORTIONAL UNLOAD CONTROL SOLENOID VALVE, COMPRESSOR 1B
185	34R10	PROPORTIONAL UNLOAD CONTROL SOLENOID VALVE, COMPRESSOR 1B
275	3L1	EVAPORATOR REFRIGERANT LIQUID LEVEL SENSOR, CIRCUIT 1
266	3PT1	SACTION REFRIGERANT PRESSURE TRANSDUCER, CIRCUIT 1, COMPRESSOR 1A
266	3PT2	SACTION REFRIGERANT PRESSURE TRANSDUCER, CIRCUIT 1, COMPRESSOR 1B
278	3PT3	OIL PRESSURE TRANSDUCER, COMPRESSOR 1A
278	3PT4	OIL PRESSURE TRANSDUCER, COMPRESSOR 1B
286	3PT5	SACTION REFRIGERANT PRESSURE TRANSDUCER, CIRCUIT 1, COMPRESSOR 1B
35	3PT6	SACTION REFRIGERANT PRESSURE TRANSDUCER, CIRCUIT 1, COMPRESSOR 1B
75,86	3PS2	HIGH PRESSURE CUTOFF SWITCH, COMPRESSOR 1A
281	3PT7	HIGH PRESSURE CUTOFF SWITCH, COMPRESSOR 1B
281	3PT8	OIL TEMPERATURE SENSOR, CIRCUIT 1, COMPRESSOR 1A
122	3PT9	OIL TEMPERATURE SENSOR, CIRCUIT 1, COMPRESSOR 1B
136	3PT10	CONDENSER FAN INVERTER DRIVE 2
136	3PT11	CONDENSER FAN INVERTER DRIVE 2
263	3PT12	ELECTRONIC EXPANSION VALVE CIRCUIT 1
3	5B1	ETAC CUSTOMER SUPPLIED COMPONENTS, LOCATION 5
222	5K4	CHILLER WATER PUMP MOTOR
223	5K5	UNIT STATUS RELAY, PROGRAMMABLE SIGNAL FROM MODULE, DEFAULT IS UNIT ALARM SIGNAL
223	5K6	UNIT STATUS RELAY, PROGRAMMABLE SIGNAL FROM MODULE, DEFAULT IS UNIT ALARM SIGNAL

272	EVAPORATOR ENTERING WATER TEMPERATURE	371	STEP LOAD CONTROL SOLENOID VALVE CIRCUIT 1 COMPRESSOR 1B PROPORTIONAL LOAD CONTROL SOLENOID VALVE, COMPRESSOR 1B PROPORTIONAL UNLOAD CONTROL SOLENOID VALVE, COMPRESSOR 1B
273		372	EVAPORATOR REFRIGERANT LIQUID LEVEL SENSOR, CIRCUIT 1
274		373	SUCTION REFRIGERANT PRESSURE TRANSDUCER, CIRCUIT 1, COMPRESSOR 1A
275		374	CONDENSER REFRIGERANT PRESSURE TRANSDUCER, CIRCUIT 1, COMPRESSOR 1B
276		375	OIL PRESSURE TRANSDUCER, COMPRESSOR 1A
277		376	SUCTION REFRIGERANT PRESSURE TRANSDUCER, CIRCUIT 1, COMPRESSOR 1B
278		377	HIGH PRESSURE CUTOUT SWITCH, COMPRESSOR 1A
279		378	CONDENSER FAN INVERTER DRIVE 1
280		379	CONDENSER FAN INVERTER DRIVE 2
281		380	RTAC CUSTOMER SUPPLIED COMPONENTS, LOCATION 5
282		381	CHILLER WATER PUMP MOTOR
283		382	UNIT STATUS RELAY, PROGRAMMABLE SIGNAL FROM MODULE, DEFAULT IS UNIT ALARM SIGNAL
284		383	UNIT STATUS RELAY, PROGRAMMABLE SIGNAL FROM MODULE, DEFAULT IS UNIT RUNNING
285		384	UNIT STATUS RELAY, PROGRAMMABLE SIGNAL FROM MODULE, DEFAULT IS MAXIMUM UNIT CAPACITY
286		385	UNIT STATUS RELAY, PROGRAMMABLE SIGNAL FROM MODULE, DEFAULT IS MAXIMUM UNIT CAPACITY
287		386	UNIT STATUS RELAY, PROGRAMMABLE SIGNAL FROM MODULE, DEFAULT IS LIMITED UNIT OPERATION
288		387	EXTERNAL EMERGENCY STOP INPUT RELAY
289		388	EXTERNAL AUTO STOP INPUT RELAY
290		389	EXTERNAL LOCKOUT INPUT RELAY FOR REFRIGERANT CIRCUIT 1
291		390	EXTERNAL LOCKOUT INPUT RELAY FOR REFRIGERANT CIRCUIT 2
292		391	ICE MAKING STATUS OUTPUT
293		392	CHILLER WATER FLOW SWITCH
294		393	RTAC UNIT MOUNTED COMMON COMPONENTS, LOCATION 6
295		394	CUSTOMER CONVENIENCE OUTLET
296		395	EVAPORATOR HEAT TAPE
297		396	EVAPORATOR ENTERING WATER TEMPERATURE SENSOR
298		397	EVAPORATOR LEAVING WATER TEMPERATURE SENSOR
299		398	TEMPERATURE CONTROL EVAPORATOR WATER HEATER
300		399	TEMPERATURE CONTROL EVAPORATOR WATER HEATER (OPTIONAL) EAST VIEW OR DINA VIEW DISPLAY AND INTERFACE

301	62	601	CUSTOMER CONVENIENCE OUTLET
302	68-71	602-4	EVAPORATOR HEAT TAPE
303	273	602-3	EVAPORATOR ENTERING WATER TEMPERATURE SENSOR
304	270	602	EVAPORATOR LEAVING WATER TEMPERATURE SENSOR
305	275	603	TEMPERATURE CONTROL EVAPORATOR WATER HEATER
306	68	604	TEMPERATURE CONTROL EVAPORATOR WATER HEATER (OPTIONAL) EAST VIEW OR DINA VIEW DISPLAY AND INTERFACE
307	238	605	TEMPERATURE CONTROL EVAPORATOR WATER HEATER (OPTIONAL) EAST VIEW OR DINA VIEW DISPLAY AND INTERFACE

NOTE  
1. COMPONENTS (LIDS) ARE NOT NECESSARILY WIRED ON THE IPC BUS(68) IN THE ORDER SHOWN.



REPLACES 2309-1994	AUTOCAD YERE TRANE COMPANY	2309-4881	D
REVISION DATE 9-27-01	AMERICAN STANDARD INC.	SCHEMATIC	
DRAWN BY FEL	REVISIONS 1. REVISED TO CORRECT THE MISPLACEMENT OF THE WATER HEATER COMPONENT	RTAC LARGE AIR COOLED LEGEND/LIJD BUS PANEL	
DATE 7-24-00	SIMILAR TO	THREE OR FOUR COMPRESSORS	

**CAUTION**  
USE COPPER CONDUCTORS ONLY!  
UNIT TERMINALS ARE NOT DESIGNED TO ACCEPT  
OTHER TYPES OF CONDUCTORS.  
FAILURE TO DO SO MAY CAUSE DAMAGE TO THE  
EQUIPMENT.

**ATTENTION**  
N'UTILISER QUE DES CONDUCTEURS EN CUIVRE!  
LES BORNES DE L'UNITÉ NE SONT PAS CONÇUES  
POUR RECEVOIR D'AUTRES TYPES DE CONDUCTEURS.  
L'UTILISATION D'AUTRE CONDUCTEUR PEUT  
ENDOMMAGER L'ÉQUIPEMENT.

**PRECAUCIÓN**  
UTILICE ÚNICAMENTE CONDUCTORES DE COBRE!  
LAS TERMINALES DE LA UNIDAD NO ESTÁN DISEÑADAS  
PARA ACEPTAR OTROS TIPOS DE CONDUCTORES.  
SI NO LO HACE, PUEDE OCASIONAR DAÑO AL EQUIPO.

**WARNING** ⚠️ **AVERTISSEMENT** ⚠️ **ADVERTENCIA** ⚠️

**HAZARDOUS VOLTAGE!** TENSION DANGEREUSE! VOLTAJE PELIGROSO!

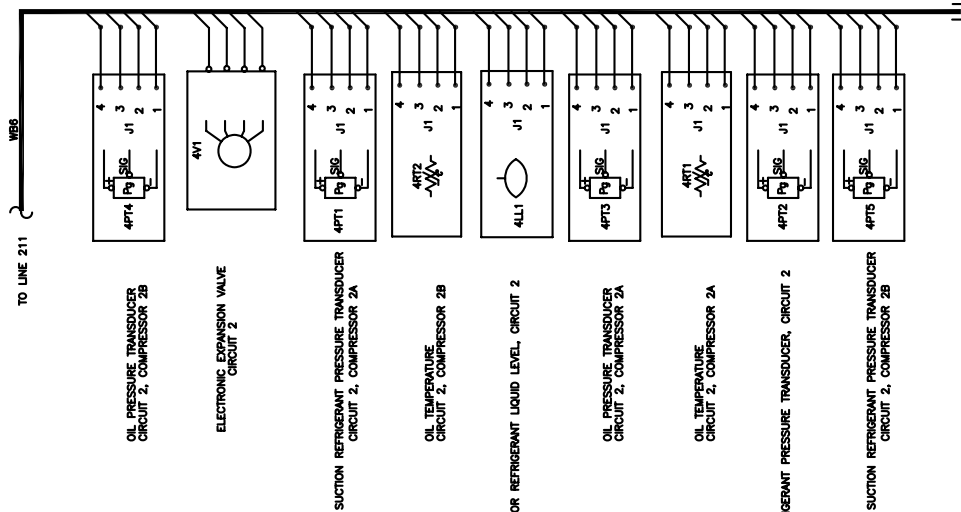
DISCONNECT ALL ELECTRIC POWER INCLUDING REMOTE DISCONNECTS AND FOLLOW LOCK OUT AND TAG INSURE THAT ALL MOTOR CAPACITORS HAVE DISCHARGED VOLTAGE BEFORE ATTEMPTING TO OUBLE INSTEAD ACTIONS FOR CAPACITOR DISCHARGE. FAILURE TO DO THE ABOVE BEFORE SERVICING COULD RESULT IN DEATH OR SERIOUS INJURY.

COUPER TOUTES LES TENSIONS ET PLUS SUIVRE LES PROCÉDURES DE TOUVE INTERVENTION. VÉRIFIER QUE TOUTS LES CAPACITORES DU MOTEUR HAYAN DÉCHARGÉS. DANS LE CAS D'UNITÉS DÉCHARGES, NE PAS RÉREALISER LES OPÉRATIONS DE L'ENTRAÎNEMENT POUR DÉCHARGER LES CONDENSATEURS. NE PAS RESPECTER CES MESURES DE PRÉCAUTION PEUT ENTRAINER DES BLESSURES GRAVES POSSANT ÊTRE MORTELLES.

DESCONECTE TODA LA ENERGÍA ELÉCTRICA, INCLUIDO LAS DESCONECCIONES REMOTAS Y SIGA LOS PROCEDIMIENTOS DE CIERRE Y SERVICIO. ASEGÚRESE DE QUE TODOS LOS CAPACITORES DEL MOTOR HAYAN DESCARGADO EL VOLTAJE ALMACENADO. ANTES DE REALIZAR LAS OPERACIONES DE MANTENIMIENTO DEL CONDENSADOR, CONSULTE LAS INSTRUCCIONES PARA LA DESCARGA DEL CONDENSADOR. EL NO REALIZAR LO ANTERIORMENTE INDICADO, PODRÍA OCASIONAR LA MUERTE O SERIAS LESIONES PERSONALES.

LINE NUMBER	DEVICE DESIGNATION	DESCRIPTION
241		
242		
243		
244		
245		
246		
247		
248		
249		
250		
251		
252		
253		
254		
255		
256		
257		
258		
259		
260		
261		
262		
263		
264		
265		
266		
267		
268		
269		
270		
271		
272		
273		
274		
275		

AREA	LOCATION	DESCRIPTION
1	CONTROL / STARTER PANEL 2	
2	REFRIGERATION CIRCUIT 2	
3		
4		
5		
6	UNIT MOUNTED	



NOTE  
1. COMPONENTS (LUIDS) ARE NOT NECESSARILY WIRED ON THE IPC BUS(WB8) IN THE ORDER SHOWN.

278 —  
 279 —  
 280 —  
 281 —  
 282 —  
 283 —  
 284 —  
 285 —  
 286 —  
 287 —  
 288 —  
 289 —  
 290 —  
 291 —  
 292 —  
 293 —  
 294 —  
 295 —  
 296 —  
 297 —  
 298 —  
 299 —  
 300 —

REPLACES 2309-2207	AUTOCAD	2309-4884	DR
REVISION DATE 9-27-01	THE TRANE COMPANY A DIVISION OF AMERICAN STANDARD INC.	SCHEMATIC RTAC LARGE AIR COOLED LEGEND/LIJD BUS PANEL 2 FOUR COMPRESSORS	
DRAWN BY PBL	THIS DRAWING IS THE PROPERTY OF THE TRANE COMPANY. IT IS TO BE USED ONLY FOR THE PROJECT AND SITE SPECIFICALLY IDENTIFIED ON THE DRAWING. IT IS NOT TO BE REPRODUCED OR COPIED IN ANY MANNER WITHOUT THE WRITTEN PERMISSION OF THE TRANE COMPANY.		
DATE 7-27-00	SIMILAR TO		

**WARNING**  
 HAZARDOUS VOLTAGE!  
 DISCONNECT ALL ELECTRIC POWER INCLUDING REMOTE DISCONNECTS AND FOLLOW LOCK OUT AND TAG PROCEDURES BEFORE SERVICING. INSURE UNITS ARE DISCHARGED. CAPACITORS HAVE STORED VOLTAGE. UNITS WITH VARIABLE SPEED DRIVES REFER TO THE SERVICE MANUAL FOR CAPACITOR DISCHARGE PROCEDURES. FAILURE TO DO THE ABOVE BEFORE SERVICING COULD RESULT IN DEATH OR SERIOUS INJURY.

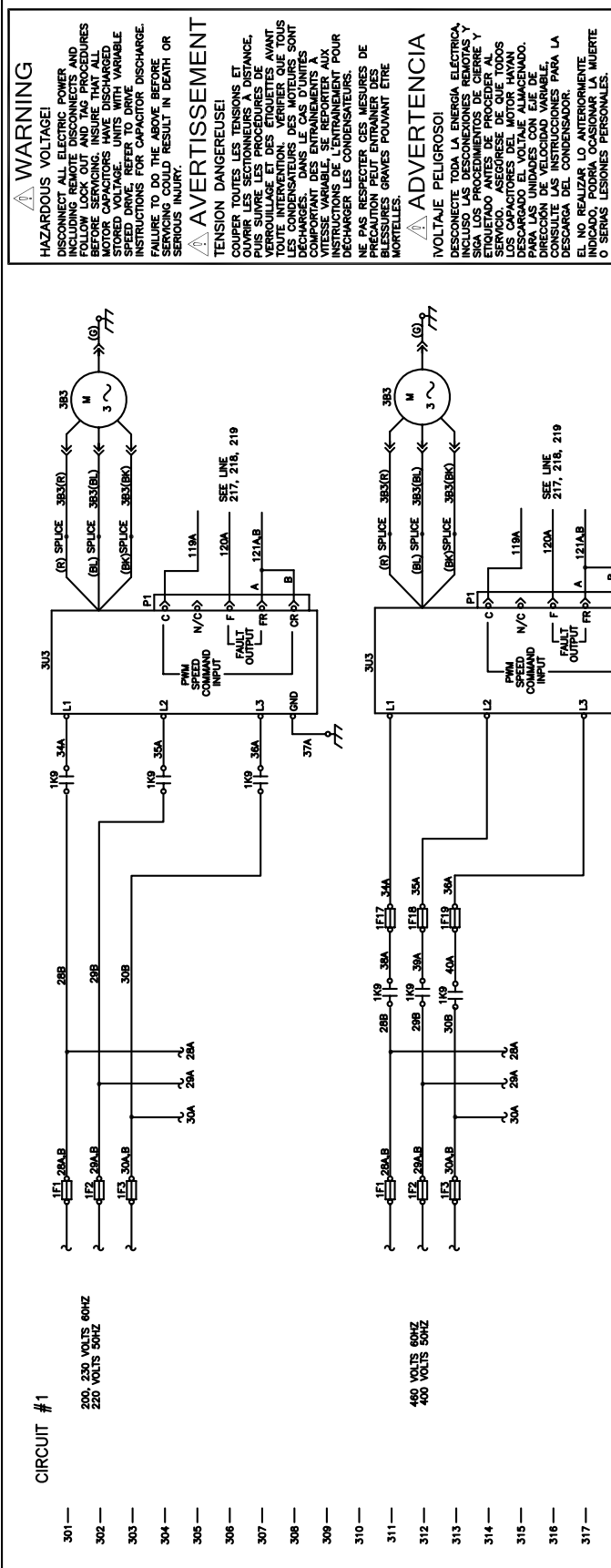
**AVERTISSEMENT**  
 TENSION DANGEREUSE!  
 COUPER TOUTES LES TENSIONS ET OUVRIR LES SECTIONNEURS A DISTANCE. PUIS SUIVRE LES PROCEDURES DE VERROUILLAGE ET D'ETIQUETAGE AVANT TOUT TRAVAIL DE SERVICING. LES CONDENSATEURS DES MOTEURS SONT DECHARGES. DANS LE CAS D'UNITES COMPORTANT DES EQUIPEMENTS A VITESSE VARIABLE, SE REFERER AUX INSTRUCTIONS DE L'ENTRAINEMENT POUR DECHARGER LES CONDENSATEURS. NE PAS RESPECTER CES MESURES DE PRECAUTION PEUT ENTRAINER DES BLESSURES GRAVES POUVANT ETRE MORTELLES.

**ADVERTENCIA**  
 VOLTAJE PELIGROSO!  
 DESCONECTE TODA LA ENERGIA ELECTRICA INCLUGO LAS DESCONEXIONES REMOTAS Y SIGA LOS PROCEDIMIENTOS DE CIERRE Y VERROUILLADO ANTES DE PROCEDER A CUALQUIER TIPO DE SERVICIO. LOS CAPACITORES DEL MOTOR HAYAN DESCARGADO EL VOLTAJE ALMACENADO. PARA LAS UNIDADES CON EJE DE VELOCIDAD VARIABLE, CONSULTE LAS INSTRUCCIONES PARA LA DESCARGA DEL CONDENSADOR. EL NO REALIZAR LO ANTERIORMENTE INDICADO, PODRIA OCASIONAR LA MUERTE O SERIAS LESIONES PERSONALES.

**CAUTION**  
 USE COPPER CONDUCTORS ONLY! UNIT TERMINALS ARE NOT DESIGNED TO ACCEPT OTHER TYPES OF CONDUCTORS. FAILURE TO DO SO MAY CAUSE DAMAGE TO THE EQUIPMENT.

**PRECAUCIÓN**  
 N'UTILISER QUE DES CONDUCTEURS EN CUIVRE! LES BORNES DE L'UNITÉ NE SONT PAS CONÇUES POUR RECEVOIR D'AUTRES TYPES DE CONDUCTEURS. L'UTILISATION DE TOUT AUTRE CONDUCTEUR PEUT ENDOMMAGER L'EQUIPEMENT.

**ATTENTION**  
 UTILICE ÚNICAMENTE CONDUCTORES DE COBRE! LAS TERMINALES DE LA UNIDAD NO ESTÁN DISEÑADAS PARA ACEPTAR OTROS TIPOS DE CONDUCTORES. SI NO LO HACE, PUEDE OCASIONAR DAÑO AL EQUIPO.

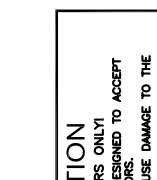
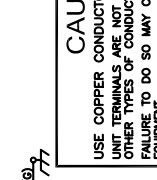
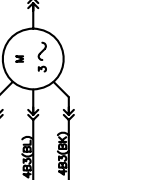
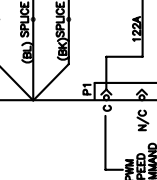
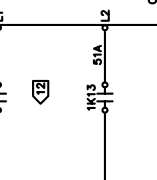
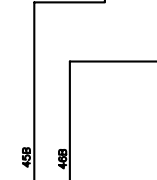
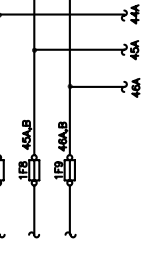


**CAUTION**  
 USE COPPER CONDUCTORS ONLY!  
 UNIT TERMINALS ARE NOT DESIGNED TO ACCEPT OTHER TYPES OF CONDUCTORS.

329 —  
330 —  
331 —  
332 —  
333 —  
334 —  
335 —  
336 —  
337 —  
338 —  
339 —  
340 —  
341 —  
342 —  
343 —  
344 —  
345 —  
346 —  
347 —  
348 —  
349 —  
350 —  
351 —  
352 —  
353 —  
354 —  
355 —  
356 —  
357 —  
358 —  
359 —  
360 —

CIRCUIT #2

200, 230 VOLTS 60HZ  
220 VOLTS 50HZ

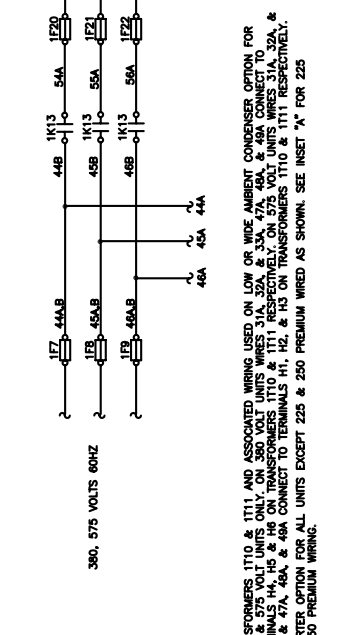
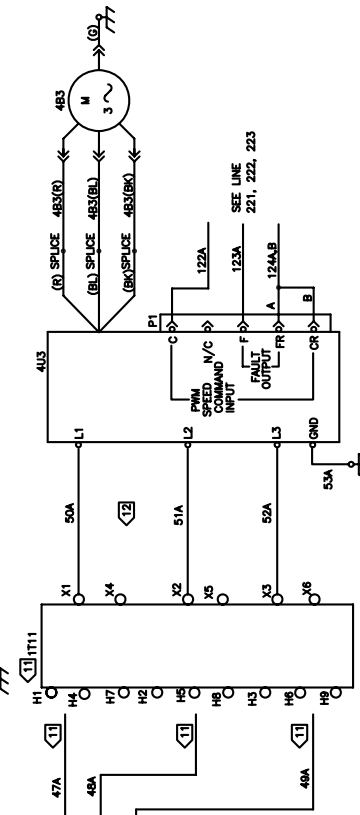
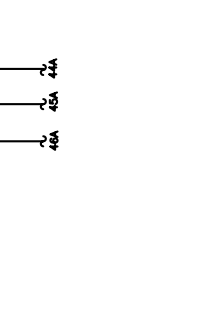
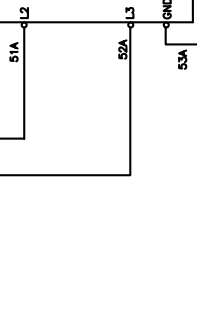
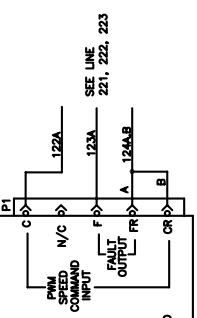
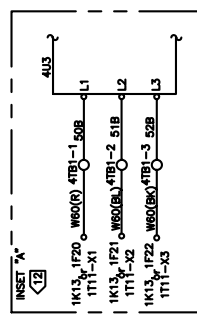


**CAUTION**  
USE COPPER CONDUCTORS ONLY!  
UNIT TERMINALS ARE NOT DESIGNED TO ACCEPT  
OTHER TYPES OF CONDUCTORS.  
FAILURE TO DO SO MAY CAUSE DAMAGE TO THE  
EQUIPMENT.

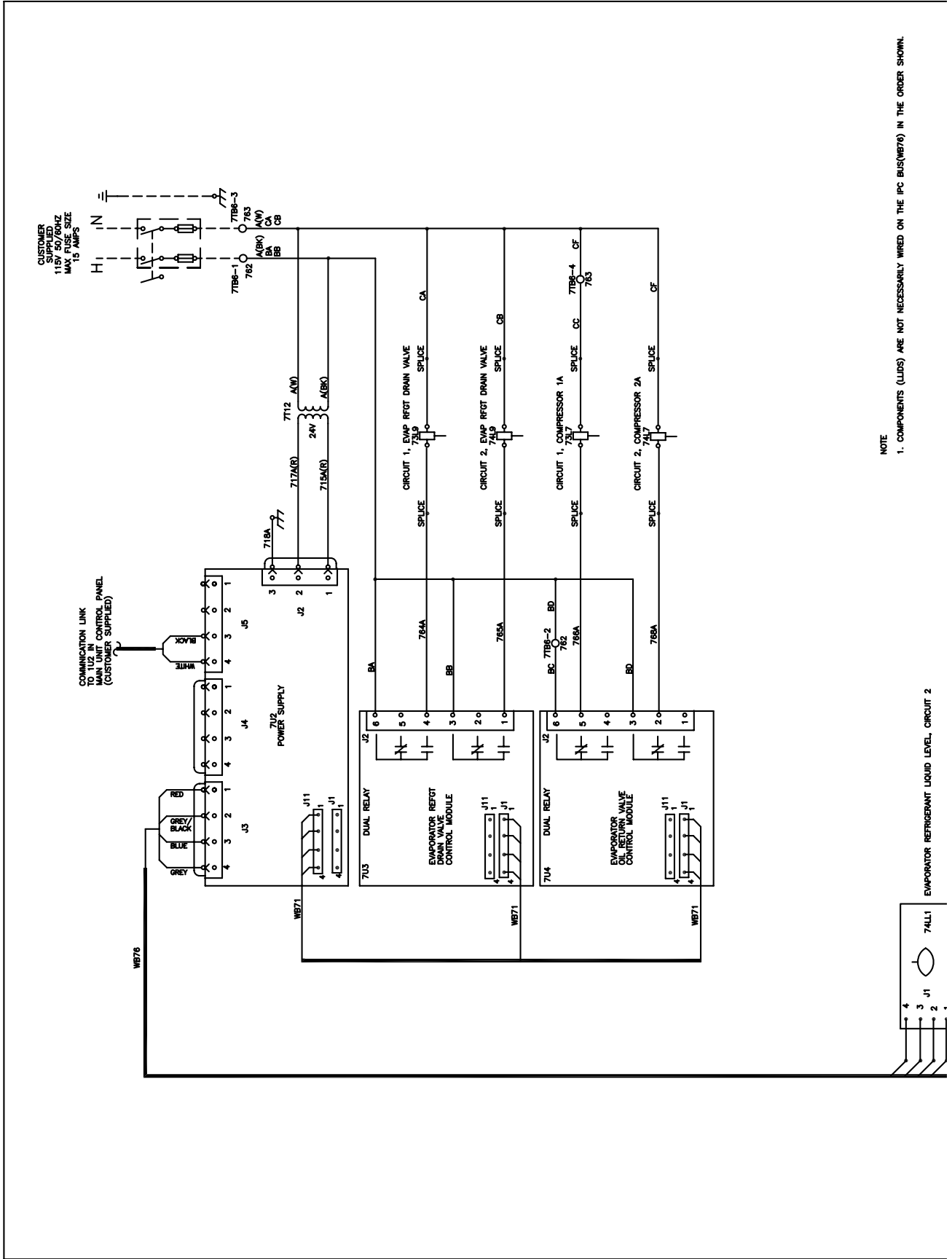
**ATTENTION**  
N'UTILISER QUE DES CONDUCTEURS EN CUIVRE!  
LES BORNES DE L'UNITÉ NE SONT PAS CONÇUES  
POUR RECEVOIR D'AUTRES TYPES DE CONDUCTEURS.  
L'UTILISATION DE TOUT AUTRE CONDUCTEUR PEUT  
ENDOMMAGER L'ÉQUIPEMENT.

**PRECAUCIÓN**  
¡UTILICE ÚNICAMENTE CONDUCTORES DE COBRE!  
LAS TERMINALES DE LA UNIDAD NO ESTÁN DISEÑADAS  
PARA ACEPTAR OTROS TIPOS DE  
SI NO LO HACE, PUEDE OCASIONAR DAÑO AL EQUIPO.

REPLACES 2309-1957	AUTOCAD	2309-2243	REV C
REVISION DATE 03-20-01	TRIE STRAIN COMPANY A DIVISION OF AMERICAN AIR TRAINING INC. THE STRAIN COMPANY, INC. 10000 WILSON AVENUE MILFORD, OHIO 45130 TEL: 513-481-1111 FAX: 513-481-1111	SCHMATIC RTAC MEDIUM/LARGE AIR COOLED 2 COMPRESSOR UNITS FAN WIRING FOR INVERTERS LOW AND WIDE AMBIENT OPTION	
DRAWN BY PBL	SIMILAR TO		
DATE 01-03-01			

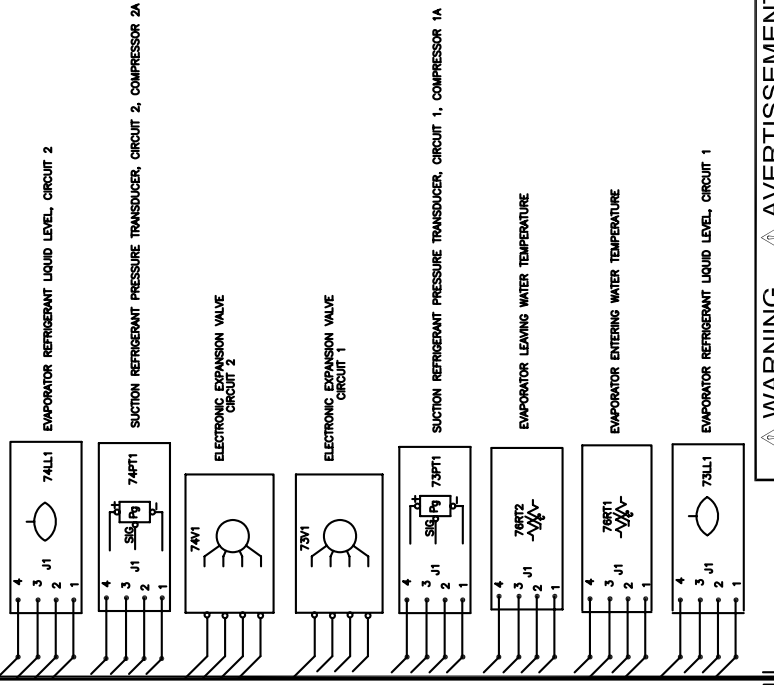


NOTES:  
 1 TRANSFORMERS 1T10 & 1T11 AND ASSOCIATED WIRING USED ON LOW OR WIDE AMBIENT CONDENSER OPTION FOR 360 & 575 VOLT UNITS. ONLY ON 360 VOLT UNITS WIRES 51A, 52A & 53A, 54A, 55A, 56A, 57A, 58A, & 59A CONNECT TO 50A, 51A, 52A, 53A, 54A, 55A, 56A, 57A, 58A, & 59A CONNECT TO TERMINALS H1, H2, & H3 ON TRANSFORMERS 1T10 & 1T11 RESPECTIVELY.  
 2 INVERTER OPTION FOR ALL UNITS EXCEPT 225 & 250 PREMIUM WIRED AS SHOWN. SEE INSET "A" FOR 225 & 250 PREMIUM WIRING.



NOTE  
 1. COMPONENTS (LUDS) ARE NOT NECESSARILY WIRED ON THE IPC BUS(WB76) IN THE ORDER SHOWN.

NOTE  
1. COMPONENTS (LIDS) ARE NOT NECESSARILY WIRED ON THE PC BUS (W676) IN THE ORDER SHOWN.



WIRE DESIGNATION	DESCRIPTION
7U2	POWER SUPPLY MODULE REMOTE EVAP
7U3	DUAL RELAY EVAPORATOR ON RETURN VALVE CONTROL MODULE
7U4	EVAP OIL RETURN SOLENOID VALVE CKT 1 COMPR 1A
73L9	EVAP REFRIGERANT DRAIN VALVE CIRCUIT 1 COMPR 1A
74L9	EVAP REFRIGERANT DRAIN VALVE CIRCUIT 2
74L9	EVAP REFRIGERANT DRAIN VALVE CIRCUIT 2
74V1	24V TRANSFORMER
73L1	EVAPORATOR REFRIGERANT LIQUID LEVEL SENSOR CKT 1
73L1	EVAPORATOR REFRIGERANT LIQUID LEVEL SENSOR CKT 2
73PT1	SUCTION REFRIGERANT PRESSURE TRANSDUCER CKT 1 COMPRESSOR 1A
73PT1	SUCTION REFRIGERANT PRESSURE TRANSDUCER CKT 2 COMPRESSOR 2A
76RT1	EVAPORATOR LEAVING WATER TEMPERATURE SENSOR
76RT1	EVAPORATOR ENTERING WATER TEMPERATURE SENSOR
73V1	EXPANSION VALVE CKT 1
74V1	EXPANSION VALVE CKT 2
74V1	TERMINAL STRIP

REPLACES 2309-1970	AUTOCAD	2309-4899	RE
REVISION DATE 3-12-02	THE TRANE COMPANY		
DRAWN BY PBL	AMERICAN STANDARD INC.	SCHEMATIC	
DATE 11-27-01	THE TRANE COMPANY 1000 W. WASHINGTON ST. MILWAUKEE, WI 53224-1000 TEL: 414.754.2000 FAX: 414.754.2001	RTAC MEDIUM AIR COOLED	
	SIMILAR TO	REMOTE EVAP 2 COMPRESSOR UNITS	

**CAUTION**  
USE COPPER CONDUCTORS ONLY!  
UNIT TERMINALS ARE NOT DESIGNED TO ACCEPT OTHER TYPES OF CONDUCTORS.  
FAILURE TO DO SO MAY CAUSE DAMAGE TO THE EQUIPMENT.

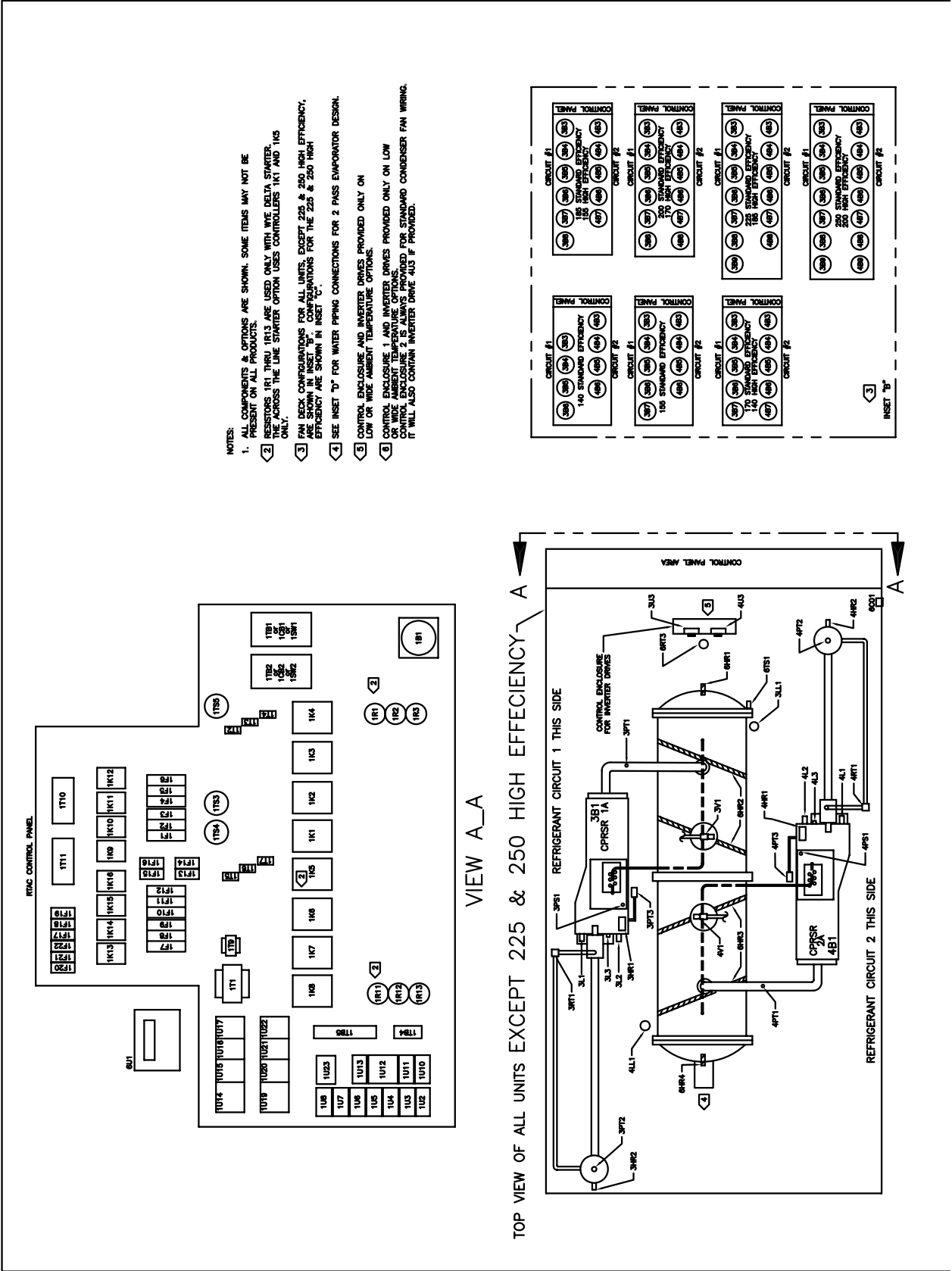
**ATTENTION**  
N'UTILISER QUE DES CONDUCTEURS EN CUIVRE!  
LES BORNES DE L'UNITÉ NE SONT PAS CONÇUES POUR RECEVOIR D'AUTRES TYPES DE CONDUCTEURS.  
L'UTILISATION DE TOUT AUTRE CONDUCTEUR PEUT ENDOMMAGER L'ÉQUIPEMENT.

**PRECAUCIÓN**  
¡UTILICE ÚNICAMENTE CONDUCTORES DE COBRE!  
LAS TERMINALES DE LA UNIDAD NO ESTÁN DISEÑADAS PARA ACEPTAR OTROS TIPOS DE CONDUCTORES.  
SI NO LO HACE, PUEDE OCASIONAR DAÑO AL EQUIPO.

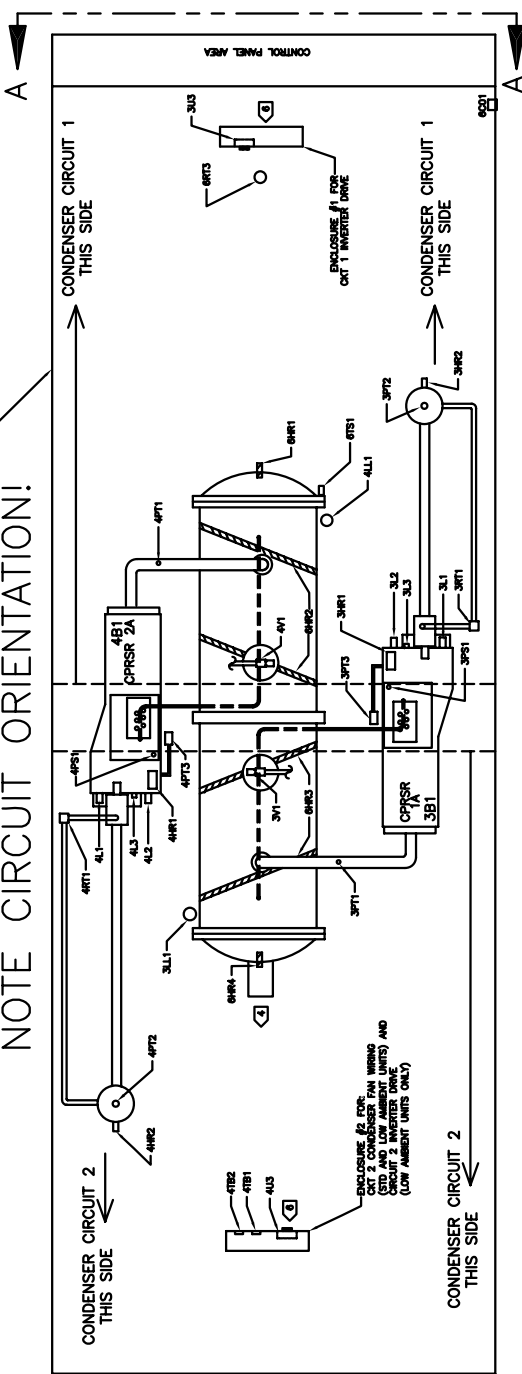
**HAZARDOUS VOLTAGE!**  
DISCONNECT ALL ELECTRIC POWER TO THE UNIT BEFORE SERVICING AND FOLLOW LOCK OUT AND TAG PROCEDURES BEFORE SERVICING. INSURE THAT ALL MOTOR CAPACITORS ARE FULLY DISCHARGED BEFORE SERVICING. STORED VOLTAGE UNITS WITH VARIABLE SPEED DRIVE, REFER TO DRIVE INSTRUCTIONS FOR CAPACITOR DISCHARGE. DO NOT TOUCH THE CAPACITOR TERMINALS BEFORE SERVICING. FAILURE TO FOLLOW THESE PRECAUTIONS MAY RESULT IN DEATH OR SERIOUS INJURY.

**AVERTISSEMENT DANGEREUX!**  
COUPER TOUTE L'ÉNERGIE ÉLECTRIQUE À L'UNITÉ AVANT LE SERVICE ET SUIVRE LES PROCÉDURES DE VERROUILLAGE ET DES ÉTIQUETTES AVANT TOUTE INTERVENTION. VÉRIFIER QUE TOUTES LES CAPACITÉS DES MOTEURS SONT DÉCHARGÉES DANS LE CAS D'UNITÉS À VITESSE VARIABLE. SE REPORTER AUX INSTRUCTIONS DE LA UNITÉ POUR LE DÉCHARGEMENT DES CONDENSATEURS. NE PAS TOUCHER LES CONDENSATEURS AVANT LE SERVICE. LE NON RESPECT DE CES MESURES DE PRÉCAUTION PEUT ENTRAÎNER DES BLESSURES GRAVES POUVANT ÊTRE MORTELLES.

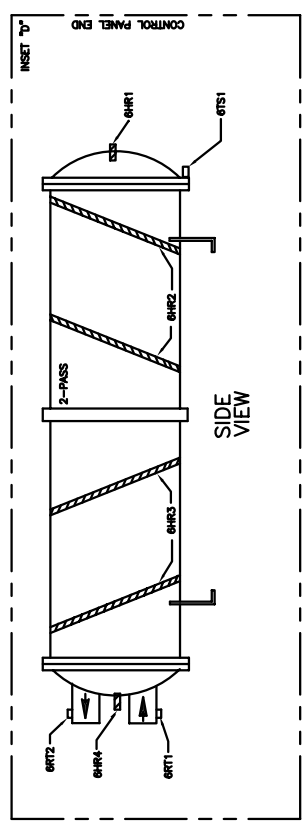
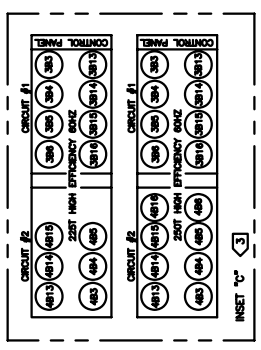
**ADVERTENCIA**  
¡VOLTAJE PELIGROSO!  
DESCONECTE TODA LA ENERGÍA ELÉCTRICA A LA UNIDAD ANTES DEL SERVICIO Y SIGA LOS PROCEDIMIENTOS DE CIERRE Y ETIQUETADO ANTES DE PROCEDER AL SERVICIO. ASEGURESE DE QUE TODOS LOS CAPACITORES DE LOS MOTORES SON DESCARGADOS EN EL VOLTAJE ALMACENADO. PARA LAS UNIDADES CON EJE DE DIRECCION DE VELOCIDAD VARIABLE, DIRIGIRSE A LAS INSTRUCCIONES PARA LA DESCARGA DEL CONDENSADOR. NO TOQUE LOS CONDENSADORES ANTES DEL SERVICIO. EL NO REALIZAR LO ANTERIORMENTE PUEDE OCASIONAR LA MUERTE O SERIAS LESIONES PERSONALES.

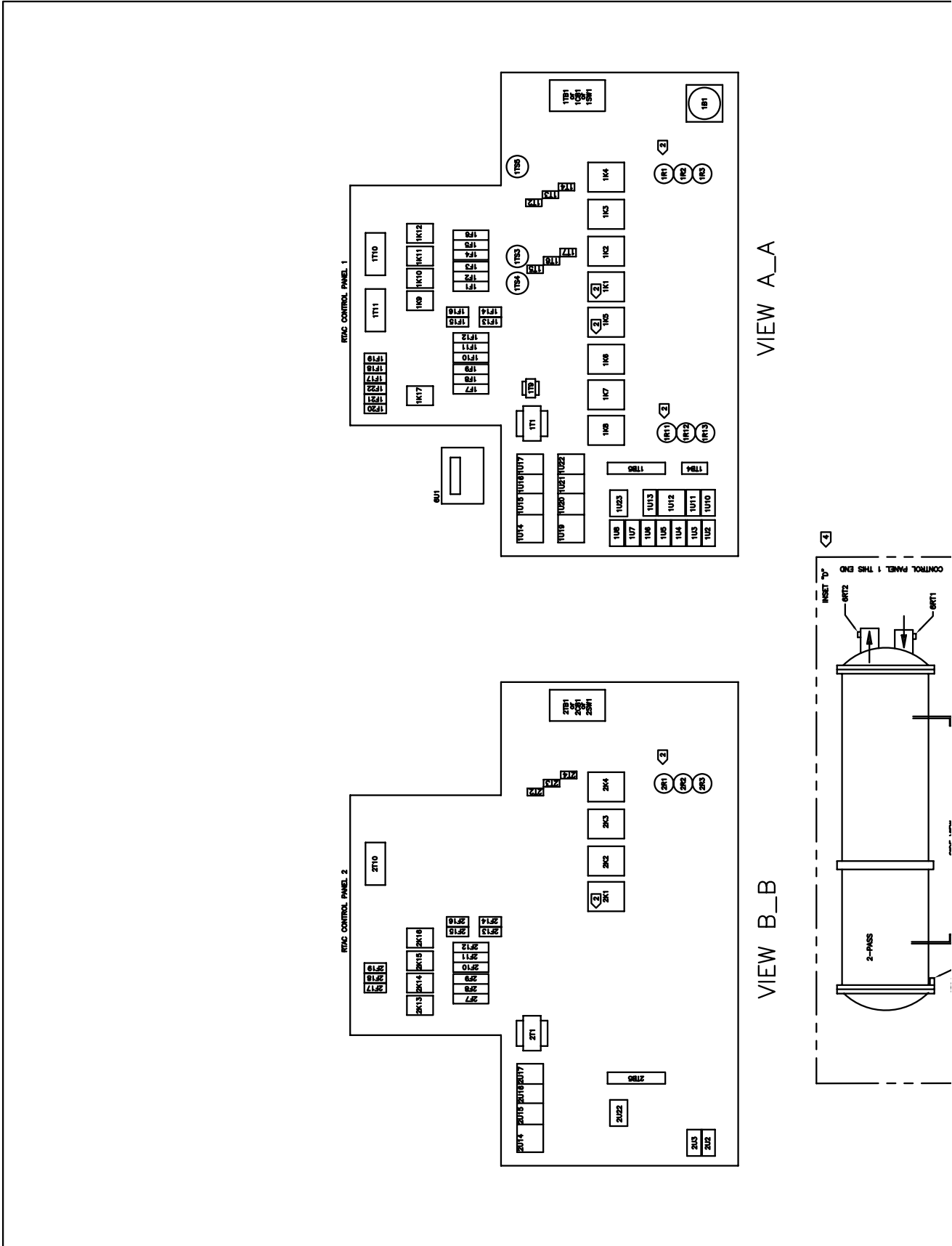


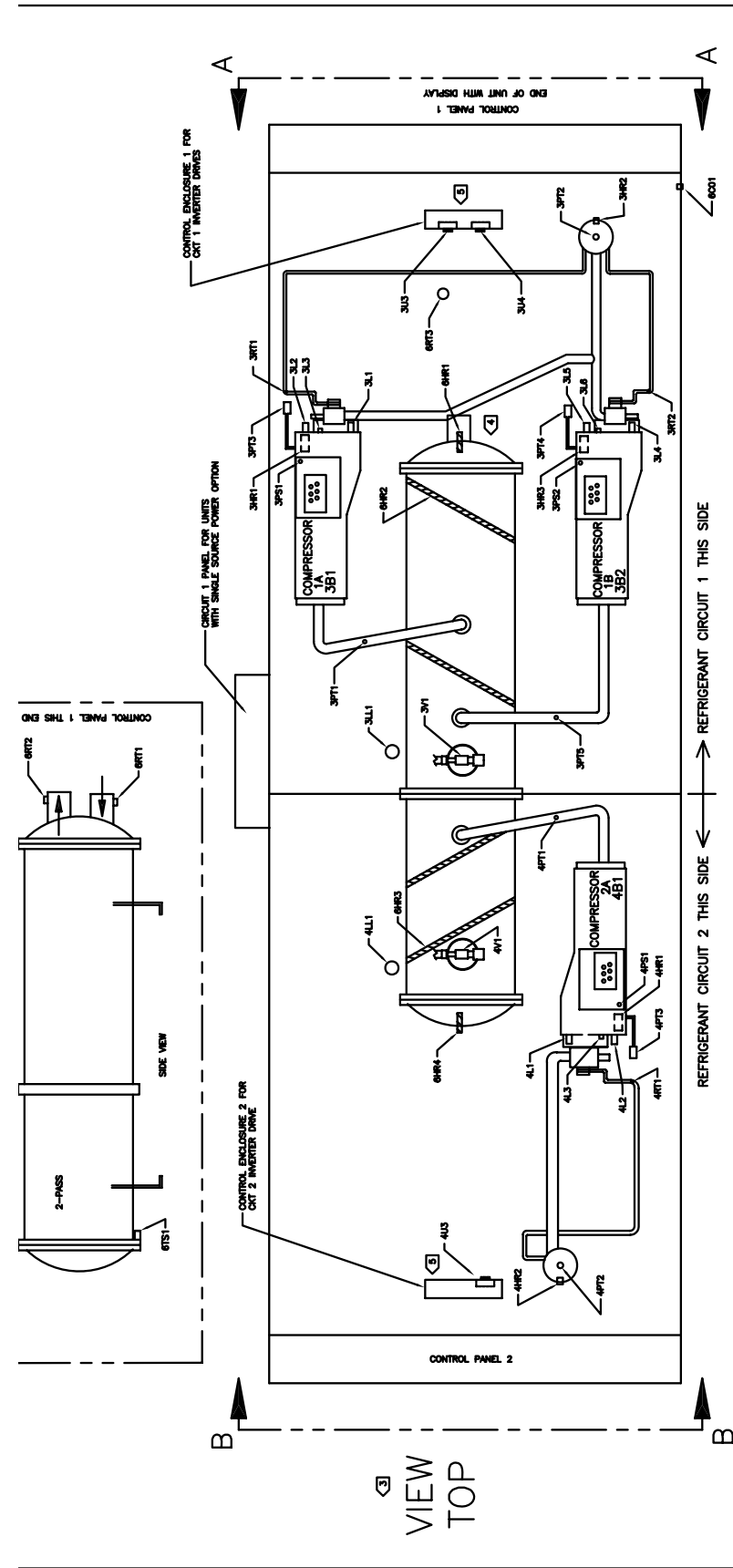
TOP VIEW OF 225 & 250 HIGH EFFICIENCY-  
NOTE CIRCUIT ORIENTATION!



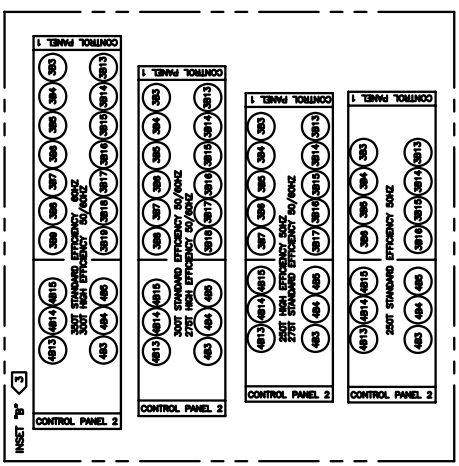
REPLACES 2309-1368	AUTOCAD	2309-4871	REV B
REVISION DATE	THIS TRANE COMPANY A DIVISION OF AMERICAN STANDARD INC.	COMPONENT LOCATION	
DRAWN BY FEL	TRANE & COMPANY 1000 W. GREENWOOD AVENUE MILWAUKEE, WISCONSIN 53227 PHONE 414-224-2000 FAX 414-224-2001	RTAC MEDIUM/LARGE AIR COOLED 2 COMPRESSOR UNITS	
DATE 2-4-03	SIMILAR TO		



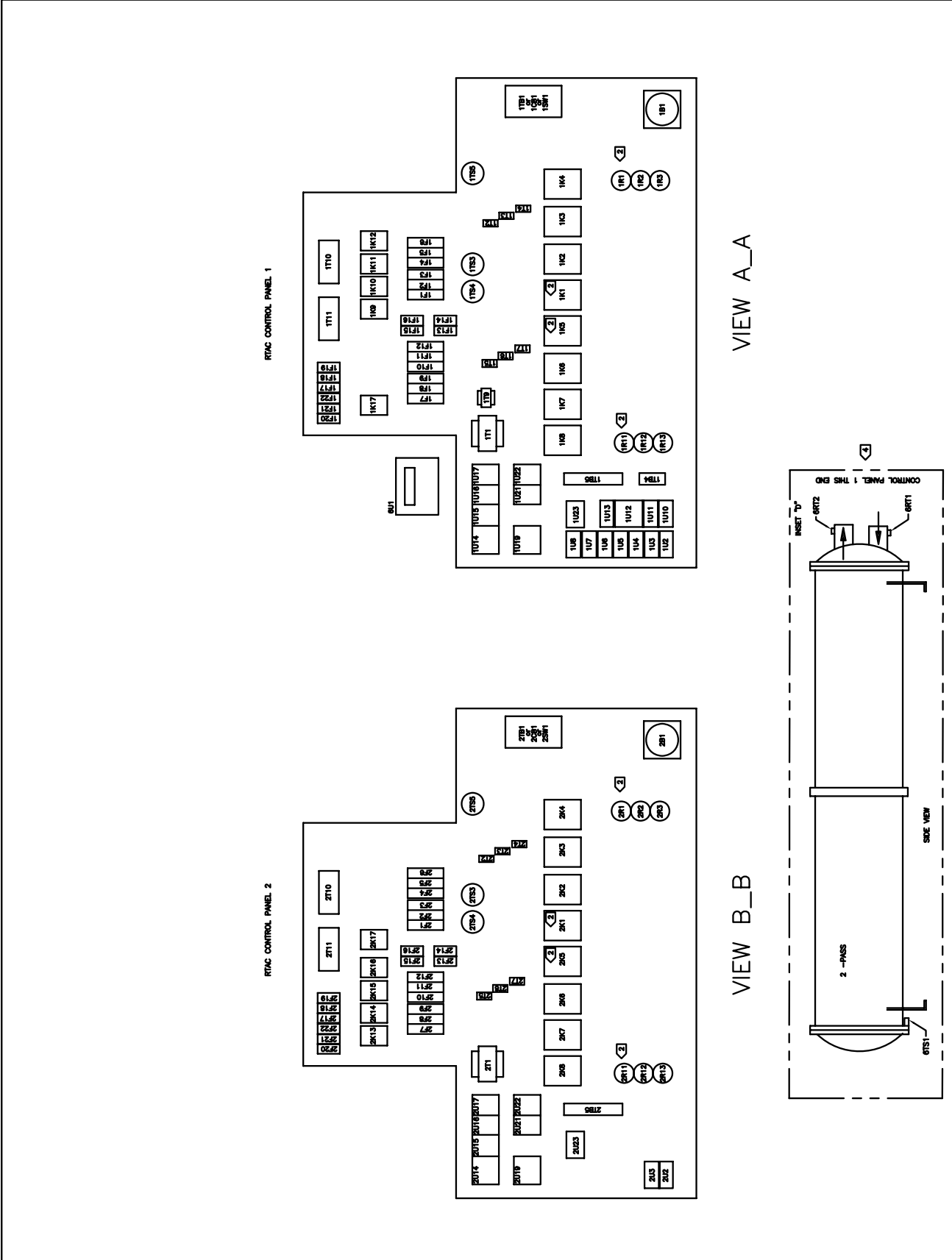


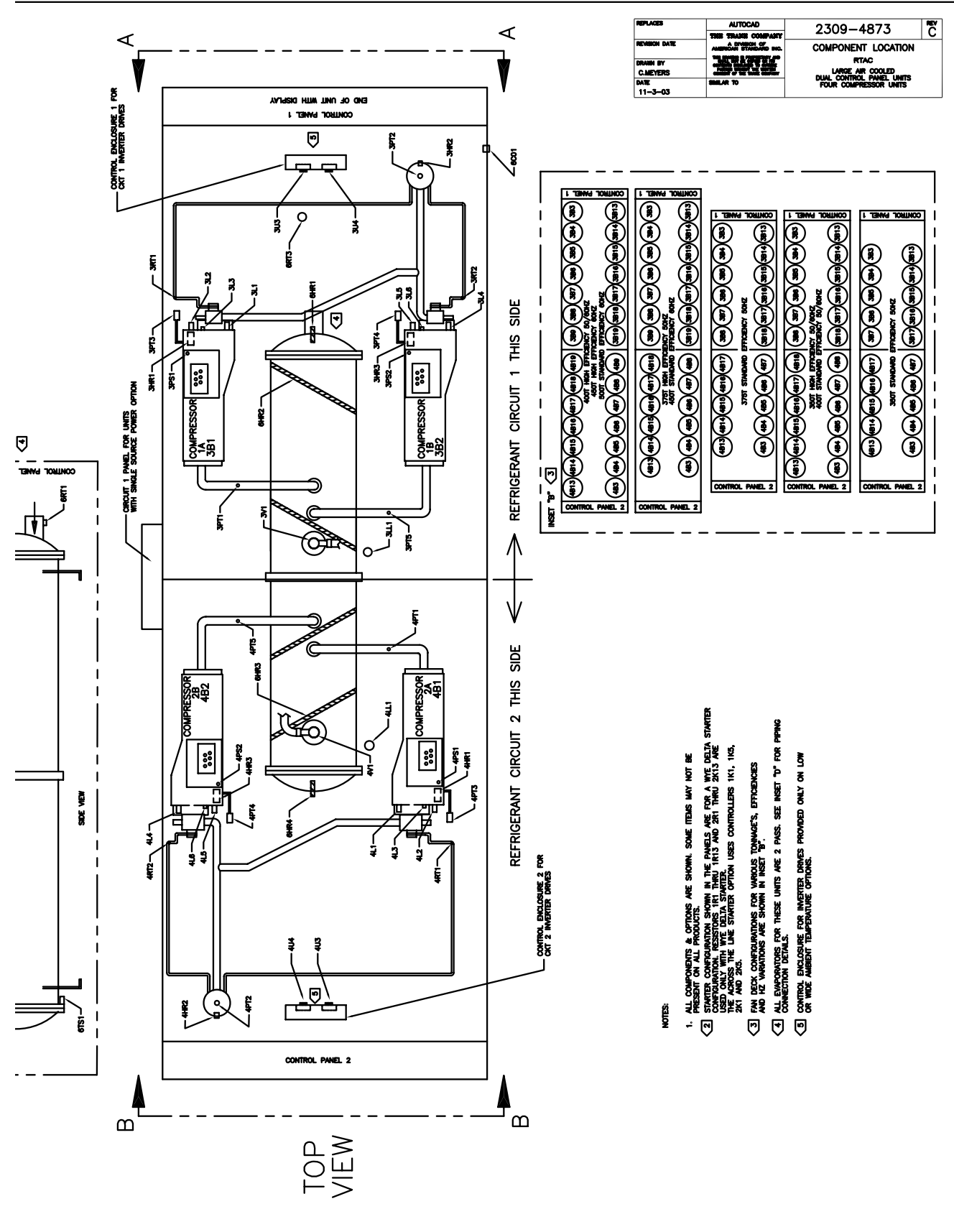


REPLACES	AUTOCAD	2309-4874	REV C
REVISION DATE	THE TRANE COMPANY A DIVISION OF AMERICAN OVERSEAS AIR-CONDITIONING INC.	COMPONENT LOCATION	
DRAWN BY		RTAC	
CHECKED BY		LARGE AIR COOLED	
DATE	11-3-03	DUAL CONTROL PANEL UNITS	
		THREE COMPRESSOR UNITS	



- NOTES:
1. ALL COMPONENTS & OPTIONS ARE SHOWN. SOME ITEMS MAY NOT BE PRESENT ON ALL PRODUCTS.
  2. STARTER CONFIGURATION SHOWN IN THE PANELS ARE FOR A WYE-DELTA STARTER USED ONLY WITH WYE DELTA STARTER. THE LINE STARTER OPTION USES CONTROLLERS 1K1, 1K5 AND 2K1 ONLY.
  3. FAN DECK CONFIGURATIONS FOR VARIOUS TONNAGES, EFFICIENCIES AND IFL VARIATIONS ARE SHOWN IN INSET 'B'.
  4. ALL EVAPORATORS FOR THESE UNITS ARE 2 PHAS. SEE INSET 'D' FOR PIPING CONNECTION DETAILS.
  5. CONTROL ENCLOSURE FOR INVERTER DRIVES PROVIDED ONLY ON LOW OR WIDE AMBIENT OPTIONS.





REPLACES	AUTOCAD	2309-4873	REV
REVISION DATE	THIS TRANE COMPANY A DIVISION OF AMERICAN STANDARD INC.	COMPONENT LOCATION	C
DRAWN BY	TRANE	RTAC	
DATE	11-3-03	LARGE AIR COOLED DUAL CONTROL PANEL UNITS FOUR COMPRESSOR UNITS	
	SIMILAR TO		

- NOTES:
1. ALL COMPONENTS & OPTIONS ARE SHOWN. SOME ITEMS MAY NOT BE PRESSURE OR PROTECTIVE.
  2. STARTER CONFIGURATION SHOWN IN THE PANELS ARE FOR A WYE DELTA STARTER. CONFIGURATION, RESISTORS, RT1 THRU RT13 AND 2R1 THRU 2R13 ARE USED ONLY WITH WYE DELTA STARTER.
  3. FAN DECK CONFIGURATIONS FOR VARIOUS TONNAGES, EFFICIENCIES AND Hz VARIATIONS ARE SHOWN IN INSET "B".
  4. ALL EVAPORATORS FOR THESE UNITS ARE 2 PASS. SEE INSET "D" FOR PIPING CONNECTION DETAILS.
  5. CONTROL ENCLOSURE FOR INVERTER DRIVES PROVIDED ONLY ON LOW OR WIDE AMBIENT TEMPERATURE OPTIONS.



REPLACES	AUTOCAD	REV	C
REVISION DATE	THE TRANS COMPANY	2309-2246	
5-2-01	AMERCO INTERNATIONAL INC.	CUSTOMER LUG SIZE	
DRAWN BY	THE LUGS ARE PROVIDED FOR THE CUSTOMER'S USE AND THE CUSTOMER IS RESPONSIBLE FOR THE PROPER INSTALLATION OF THE LUGS TO THE COMPRESSORS.	RTAC	
REL	DATE	LARGE AIR COOLED UNITS	
4/11/01	4/11/01	3 DR 4 COMPRESSORS	

WIRE SIZE RANGE FOR FACTORY PROVIDED LUGS FOR CUSTOMER POWER WIRING CONNECTIONS

VOLTAGE	SINGLE SOURCE POWER ELECTRICAL CIRCUIT 1 & 2 (CENTRAL BOX)		ELECTRICAL CIRCUIT 1 DUAL SOURCE POWER (PANEL 1)		ELECTRICAL CIRCUIT 2 DUAL SOURCE POWER (PANEL 2)	
	UNIT SIZE, EFFICIENCY	LUG WIRE SIZE RANGE	UNIT SIZE, EFFICIENCY	LUG WIRE SIZE RANGE	UNIT SIZE, EFFICIENCY	LUG WIRE SIZE RANGE
200/60/3	ALL	NOT AVAILABLE				
230/60/3	ALL	NOT AVAILABLE				
380/60/3	350 STD EFF, 450, 500	NOT AVAILABLE				
460/60/3	275, 300, 350 HIGH EFF, 400	FOUR 2 AVG - 600 MCM				
575/60/3	ALL	FOUR 2 AVG - 600 MCM				
400/50/3	ALL	FOUR 2 AVG - 600 MCM				

UNITS WITH DUAL POINT POWER OPTION & TERMINALS FOR CUST CONNECTION

VOLTAGE	SINGLE SOURCE POWER ELECTRICAL CIRCUIT 1 & 2 (CENTRAL BOX)		ELECTRICAL CIRCUIT 1 DUAL SOURCE POWER (PANEL 1)		ELECTRICAL CIRCUIT 2 DUAL SOURCE POWER (PANEL 2)	
	UNIT SIZE, EFFICIENCY	LUG WIRE SIZE RANGE	UNIT SIZE, EFFICIENCY	LUG WIRE SIZE RANGE	UNIT SIZE, EFFICIENCY	LUG WIRE SIZE RANGE
200/60/3			ALL	FOUR 2 AVG - 600 MCM	350 HIGH EFF, 400, 450, 500	FOUR 2 AVG - 600 MCM
230/60/3			ALL	FOUR 2 AVG - 600 MCM	275, 300, 350 STD EFF	TWO 2 AVG - 600 MCM
380/60/3			300, 350 STD EFF, 400, 450, 500	THREE 1/0 AVG - 500 MCM	350 HIGH EFF, 400, 450, 500	FOUR 2 AVG - 600 MCM
460/60/3			275, 350 HIGH EFF	TWO 2 AVG - 600 MCM	350 HIGH EFF	FOUR 2 AVG - 600 MCM
575/60/3			ALL	TWO 2 AVG - 600 MCM	275, 300, 350	THREE 1/0 AVG - 500 MCM
400/50/3			ALL	TWO 2 AVG - 600 MCM	ALL	TWO 2 AVG - 600 MCM
			ALL	TWO 2 AVG - 600 MCM	ALL	TWO 2 AVG - 600 MCM

UNITS WITH DUAL POINT POWER OPTION & DISC SWITCH FOR CUST CONNECTION

VOLTAGE	SINGLE SOURCE POWER ELECTRICAL CIRCUIT 1 & 2 (CENTRAL BOX)		ELECTRICAL CIRCUIT 1 DUAL SOURCE POWER (PANEL 1)		ELECTRICAL CIRCUIT 2 DUAL SOURCE POWER (PANEL 2)	
	UNIT SIZE, EFFICIENCY	LUG WIRE SIZE RANGE	UNIT SIZE, EFFICIENCY	LUG WIRE SIZE RANGE	UNIT SIZE, EFFICIENCY	LUG WIRE SIZE RANGE
200/60/3			ALL	FOUR 250 MCM - 500 MCM	350 HIGH EFF, 400, 450, 500	FOUR 250MCM - 500 MCM
230/60/3			300, 350 STD EFF, 400, 450, 500	FOUR 250 MCM - 500 MCM	275, 300, 350 STD EFF	TWO 3/0 AVG - 500 MCM
380/60/3			275, 350 HIGH EFF	THREE 1/0 AVG - 500 MCM	350 HIGH EFF	FOUR 250 MCM - 500 MCM
460/60/3			300, 350 STD EFF, 400, 450, 500	THREE 1/0 AVG - 500 MCM	275, 300, 350 STD EFF	THREE 1/0 AVG - 500 MCM
575/60/3			275, 350 HIGH EFF	TWO 3/0 AVG - 500 MCM	275, 300, 350	TWO 3/0 AVG - 500 MCM
400/50/3			ALL	TWO 3/0 AVG - 500 MCM	ALL	TWO 3/0 AVG - 500 MCM
			ALL	TWO 3/0 AVG - 500 MCM	ALL	TWO 3/0 AVG - 500 MCM

UNITS WITH DUAL POINT POWER OPTION & CIRCUIT BREAKER FOR CUST CONNECTION

VOLTAGE	SINGLE SOURCE POWER ELECTRICAL CIRCUIT 1 & 2 (CENTRAL BOX)		ELECTRICAL CIRCUIT 1 DUAL SOURCE POWER (PANEL 1)		ELECTRICAL CIRCUIT 2 DUAL SOURCE POWER (PANEL 2)	
	UNIT SIZE, EFFICIENCY	LUG WIRE SIZE RANGE	UNIT SIZE, EFFICIENCY	LUG WIRE SIZE RANGE	UNIT SIZE, EFFICIENCY	LUG WIRE SIZE RANGE
200/60/3			ALL	FOUR 250 MCM - 500 MCM	350 HIGH EFF, 400, 450, 500	FOUR 250MCM - 500 MCM
230/60/3			ALL	FOUR 250 MCM - 500 MCM	275, 300, 350 STD EFF	TWO 3/0 AVG - 500 MCM
380/60/3			300, 350 STD EFF, 400, 450, 500	THREE 1/0 AVG - 500 MCM	350 HIGH EFF	FOUR 250 MCM - 500 MCM
460/60/3			275, 350 HIGH EFF	THREE 1/0 AVG - 500 MCM	275, 300, 350	THREE 1/0 AVG - 500 MCM
575/60/3			ALL	TWO 3/0 AVG - 500 MCM	ALL	TWO 3/0 AVG - 500 MCM
400/50/3			ALL	TWO 3/0 AVG - 500 MCM	ALL	TWO 3/0 AVG - 500 MCM





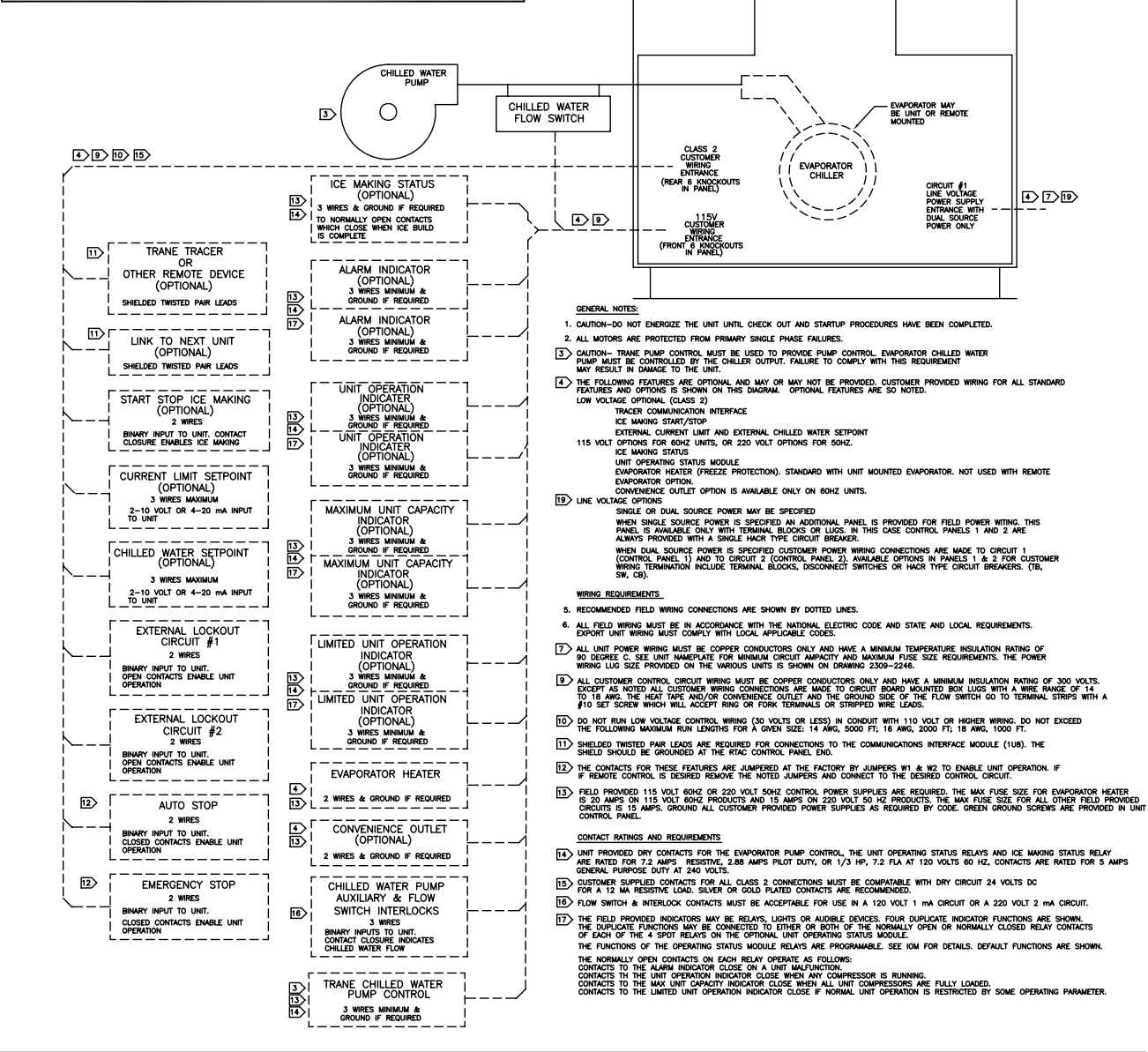




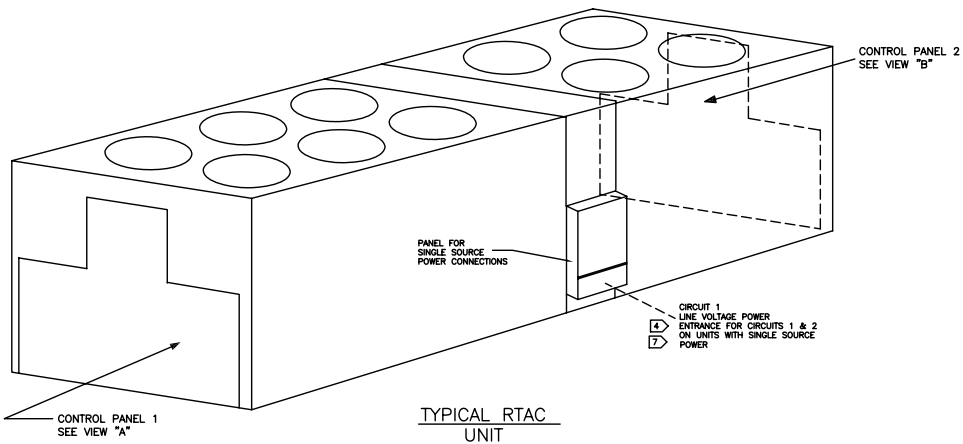
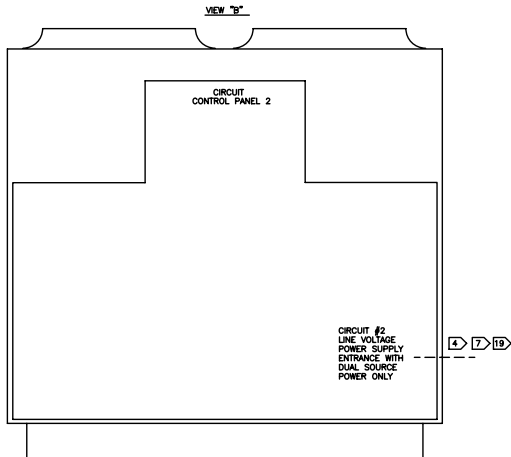
**⚠ WARNING**  
HAZARDOUS VOLTAGE!  
DISCONNECT ALL ELECTRIC POWER INCLUDING REMOTE DISCONNECTS AND FOLLOW LOCK OUT AND TAG PROCEDURES BEFORE SERVICING. INSURE THAT ALL MOTOR CAPACITORS HAVE DISCHARGED STORED VOLTAGE. UNITS WITH VARIABLE SPEED DRIVE, REFER TO DRIVE INSTRUCTIONS FOR CAPACITOR DISCHARGE. FAILURE TO DO THE ABOVE BEFORE SERVICING COULD RESULT IN DEATH OR SERIOUS INJURY.

**⚠ AVERTISSEMENT**  
TENSION DANGEREUSE!  
COUPER TOUTES LES TENSIONS ET OUVRIRE LES SECTIONNEURS A DISTANCE, PUIS SUIVRE LES PROCEDURES DE VERROUILLAGE ET DES ETIQUETTES AVANT TOUTE INTERVENTION. VÉRIFIER QUE TOUTS LES CONDENSATEURS DES MOTEURS SONT DÉCHARGÉS. DANS LE CAS D'UNITÉS COMPORTANT DES ENTRAÎNEMENTS A VITESSE VARIABLE, SE REPORTER AUX INSTRUCTIONS DE L'ENTRAÎNEMENT POUR DÉCHARGER LES CONDENSATEURS. NE PAS RESPECTER CES MESURES DE PRÉCAUTION PEUT ENTRAÎNER DES BLESSURES GRAVES POUVANT ÊTRE MORTELLES.

**⚠ ADVERTENCIA**  
VOLTAJE PELIGROSO!  
DESCONECTE TODA LA ENERGÍA ELÉCTRICA, INCLUIDO LAS DESCONEXIONES REMOTAS Y SIGA LOS PROCEDIMIENTOS DE CIERRE Y ETIQUETADO ANTES DE PROCEDER AL SERVICIO. ASEGURESE DE QUE TODOS LOS CAPACITORES DEL MOTOR HAYAN DESCARGADO EL VOLTAJE ALMACENADO. PARA LAS UNIDADES CON EJE DE DIRECCIÓN DE VELOCIDAD VARIABLE, CONSULTE LAS INSTRUCCIONES PARA LA DESCARGA DEL CONDENSADOR. EL NO REALIZAR LO ANTERIORMENTE INDICADO, PODRÍA OCASIONAR LA MUERTE O SERIAS LESIONES PERSONALES.



REPLACES	AUTOCAD	2309-2239	REV
REVISION DATE	TRIE TRANE COMPANY A DIVISION OF AMERSON STANFORD INC.		E
DRAWN BY		FIELD LAYOUT	
PRL		RTAC	
DATE		LARGE AIR COOLED 3 OR 4 COMPRESSORS	
01/09/01			



TYPICAL RTAC UNIT

<b>CAUTION</b>	<b>PRECAUCIÓN</b>	<b>ATTENTION</b>
USE COPPER CONDUCTORS ONLY! UNIT TERMINALS ARE NOT DESIGNED TO ACCEPT OTHER TYPES OF CONDUCTORS. FAILURE TO DO SO MAY CAUSE DAMAGE TO THE EQUIPMENT.	N'UTILISER QUE DES CONDUCTEURS EN CUIVRE! LES BORNES DE L'UNITÉ NE SONT PAS CONÇUES POUR RECEVOIR D'AUTRES TYPES DE CONDUCTEURS. L'UTILISATION DE TOUT AUTRE CONDUCTEUR PEUT ENDOMMAGER L'EQUIPEMENT.	UTILICE ÚNICAMENTE CONDUCTORES DE COBRE! LAS TERMINALES DE LA UNIDAD NO ESTÁN DISEÑADAS PARA ACEPTAR OTROS TIPOS DE CONDUCTORES. SI NO LO HACE, PUEDE OCASIONAR DAÑO AL EQUIPO.

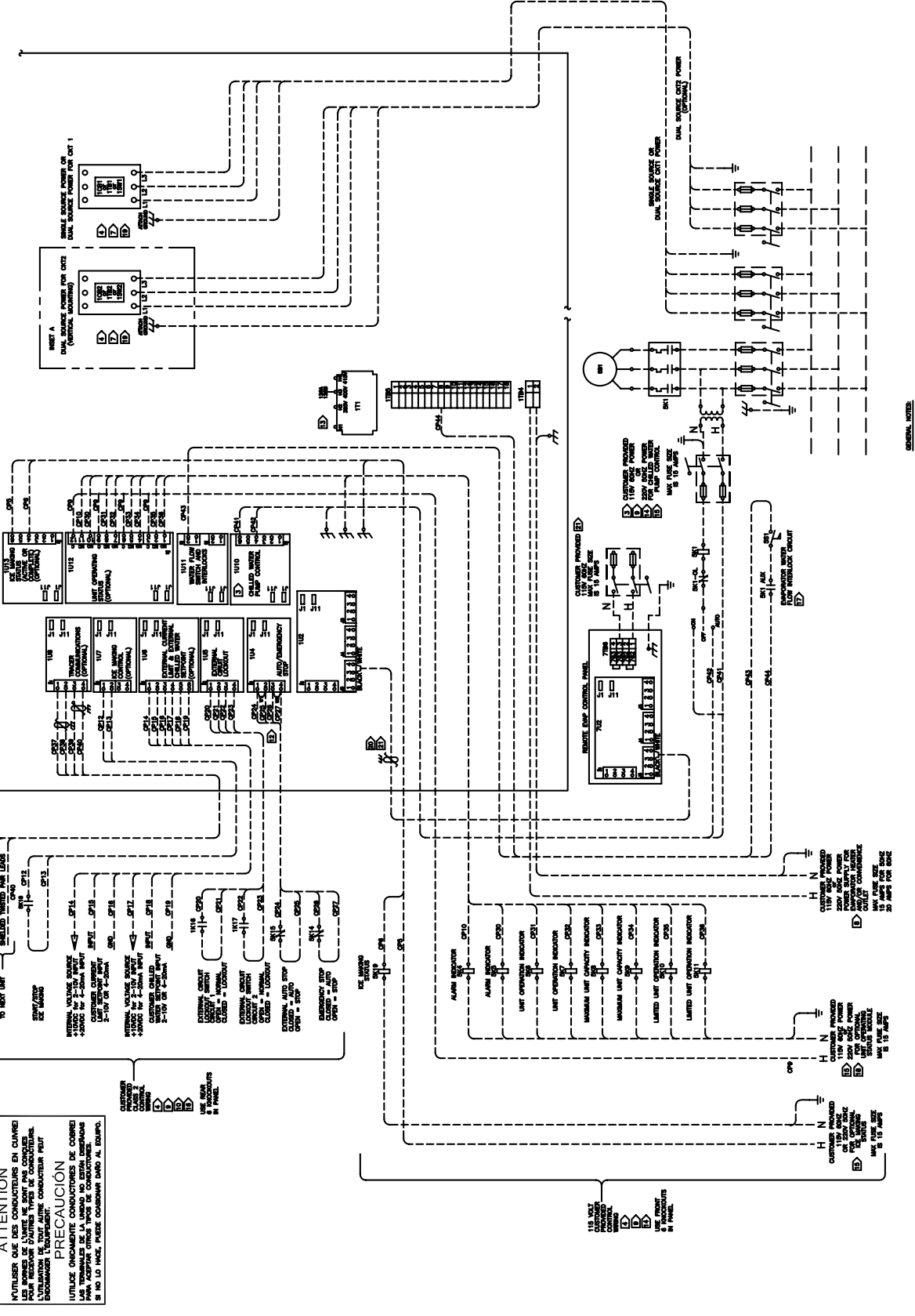
REVISED	DATE	BY	REASON
2-11-02			FIELD WORK
1-11-01			ASSEMBLY
1-11-01			ASSEMBLY
1-11-01			ASSEMBLY

2309-2208  
FIELD WORK  
ASSEMBLY

**CAUTION**  
USE COPPER CONDUCTORS ONLY.  
LIMIT TERMINALS ARE NOT DESIGNED TO ACCEPT  
OTHER TYPES OF CONDUCTORS.  
OTHER TYPES OF CONDUCTORS  
MAY CAUSE DAMAGE TO THE  
EQUIPMENT.

**ATTENTION**  
N'UTILISER QUE DES CONDUCTEURS EN CUIVRE!  
LES TERMINAUX NE SONT PAS CONÇUS POUR  
ACCEPTER D'AUTRES TYPES DE CONDUCTEURS.  
D'AUTRES TYPES DE CONDUCTEURS  
PEUVENT CAUSER DES DOMMAGES À L'ÉQUIPEMENT.

**PRECAUCION**  
UTILICE SÓLO CABLES DE COBRE.  
LOS TERMINALES SE DISEÑARON PARA  
RECEPTAR OTROS TIPOS DE CONDUCTORES.  
OTROS TIPOS DE CONDUCTORES  
PUEDE DAÑAR EL EQUIPO.



GENERAL NOTES:  
1. CAUTION—DO NOT ENERGIZE THE UNIT UNTIL CHECK OUT AND STARTUP PROCEDURES HAVE BEEN COMPLETED.  
2. ALL MOTORS ARE PROTECTED FROM PRIMARY SINGLE PHASE FAILURE.



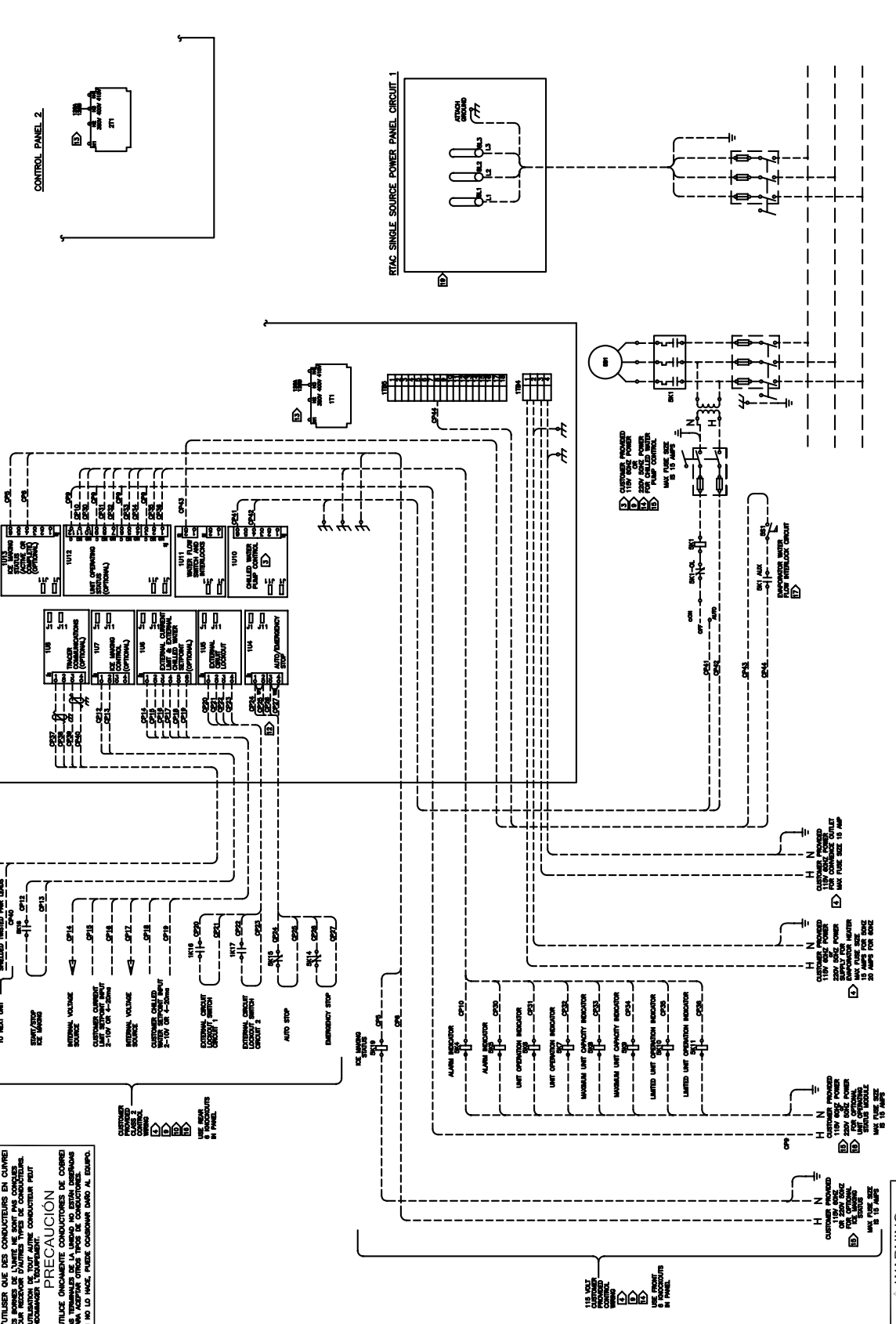
REVISED	DATE	BY	REASON
1	11-27-99		ISSUE FOR FIELD WIRING
2	03-27-00		ISSUE FOR FIELD WIRING
3	03-27-00		ISSUE FOR FIELD WIRING
4	03-27-00		ISSUE FOR FIELD WIRING
5	03-27-00		ISSUE FOR FIELD WIRING
6	03-27-00		ISSUE FOR FIELD WIRING
7	03-27-00		ISSUE FOR FIELD WIRING
8	03-27-00		ISSUE FOR FIELD WIRING
9	03-27-00		ISSUE FOR FIELD WIRING
10	03-27-00		ISSUE FOR FIELD WIRING
11	03-27-00		ISSUE FOR FIELD WIRING
12	03-27-00		ISSUE FOR FIELD WIRING
13	03-27-00		ISSUE FOR FIELD WIRING
14	03-27-00		ISSUE FOR FIELD WIRING
15	03-27-00		ISSUE FOR FIELD WIRING
16	03-27-00		ISSUE FOR FIELD WIRING
17	03-27-00		ISSUE FOR FIELD WIRING
18	03-27-00		ISSUE FOR FIELD WIRING
19	03-27-00		ISSUE FOR FIELD WIRING
20	03-27-00		ISSUE FOR FIELD WIRING
21	03-27-00		ISSUE FOR FIELD WIRING
22	03-27-00		ISSUE FOR FIELD WIRING
23	03-27-00		ISSUE FOR FIELD WIRING
24	03-27-00		ISSUE FOR FIELD WIRING
25	03-27-00		ISSUE FOR FIELD WIRING
26	03-27-00		ISSUE FOR FIELD WIRING
27	03-27-00		ISSUE FOR FIELD WIRING
28	03-27-00		ISSUE FOR FIELD WIRING
29	03-27-00		ISSUE FOR FIELD WIRING
30	03-27-00		ISSUE FOR FIELD WIRING
31	03-27-00		ISSUE FOR FIELD WIRING
32	03-27-00		ISSUE FOR FIELD WIRING
33	03-27-00		ISSUE FOR FIELD WIRING
34	03-27-00		ISSUE FOR FIELD WIRING
35	03-27-00		ISSUE FOR FIELD WIRING
36	03-27-00		ISSUE FOR FIELD WIRING
37	03-27-00		ISSUE FOR FIELD WIRING
38	03-27-00		ISSUE FOR FIELD WIRING
39	03-27-00		ISSUE FOR FIELD WIRING
40	03-27-00		ISSUE FOR FIELD WIRING
41	03-27-00		ISSUE FOR FIELD WIRING
42	03-27-00		ISSUE FOR FIELD WIRING
43	03-27-00		ISSUE FOR FIELD WIRING
44	03-27-00		ISSUE FOR FIELD WIRING
45	03-27-00		ISSUE FOR FIELD WIRING
46	03-27-00		ISSUE FOR FIELD WIRING
47	03-27-00		ISSUE FOR FIELD WIRING
48	03-27-00		ISSUE FOR FIELD WIRING
49	03-27-00		ISSUE FOR FIELD WIRING
50	03-27-00		ISSUE FOR FIELD WIRING
51	03-27-00		ISSUE FOR FIELD WIRING
52	03-27-00		ISSUE FOR FIELD WIRING
53	03-27-00		ISSUE FOR FIELD WIRING
54	03-27-00		ISSUE FOR FIELD WIRING
55	03-27-00		ISSUE FOR FIELD WIRING
56	03-27-00		ISSUE FOR FIELD WIRING
57	03-27-00		ISSUE FOR FIELD WIRING
58	03-27-00		ISSUE FOR FIELD WIRING
59	03-27-00		ISSUE FOR FIELD WIRING
60	03-27-00		ISSUE FOR FIELD WIRING
61	03-27-00		ISSUE FOR FIELD WIRING
62	03-27-00		ISSUE FOR FIELD WIRING
63	03-27-00		ISSUE FOR FIELD WIRING
64	03-27-00		ISSUE FOR FIELD WIRING
65	03-27-00		ISSUE FOR FIELD WIRING
66	03-27-00		ISSUE FOR FIELD WIRING
67	03-27-00		ISSUE FOR FIELD WIRING
68	03-27-00		ISSUE FOR FIELD WIRING
69	03-27-00		ISSUE FOR FIELD WIRING
70	03-27-00		ISSUE FOR FIELD WIRING
71	03-27-00		ISSUE FOR FIELD WIRING
72	03-27-00		ISSUE FOR FIELD WIRING
73	03-27-00		ISSUE FOR FIELD WIRING
74	03-27-00		ISSUE FOR FIELD WIRING
75	03-27-00		ISSUE FOR FIELD WIRING
76	03-27-00		ISSUE FOR FIELD WIRING
77	03-27-00		ISSUE FOR FIELD WIRING
78	03-27-00		ISSUE FOR FIELD WIRING
79	03-27-00		ISSUE FOR FIELD WIRING
80	03-27-00		ISSUE FOR FIELD WIRING
81	03-27-00		ISSUE FOR FIELD WIRING
82	03-27-00		ISSUE FOR FIELD WIRING
83	03-27-00		ISSUE FOR FIELD WIRING
84	03-27-00		ISSUE FOR FIELD WIRING
85	03-27-00		ISSUE FOR FIELD WIRING
86	03-27-00		ISSUE FOR FIELD WIRING
87	03-27-00		ISSUE FOR FIELD WIRING
88	03-27-00		ISSUE FOR FIELD WIRING
89	03-27-00		ISSUE FOR FIELD WIRING
90	03-27-00		ISSUE FOR FIELD WIRING
91	03-27-00		ISSUE FOR FIELD WIRING
92	03-27-00		ISSUE FOR FIELD WIRING
93	03-27-00		ISSUE FOR FIELD WIRING
94	03-27-00		ISSUE FOR FIELD WIRING
95	03-27-00		ISSUE FOR FIELD WIRING
96	03-27-00		ISSUE FOR FIELD WIRING
97	03-27-00		ISSUE FOR FIELD WIRING
98	03-27-00		ISSUE FOR FIELD WIRING
99	03-27-00		ISSUE FOR FIELD WIRING
100	03-27-00		ISSUE FOR FIELD WIRING

**CAUTION**  
USE COPPER CONDUCTORS ONLY  
USE OTHER TYPES OF CONDUCTORS TO ACCEPT  
OTHER TYPES OF CONDUCTORS TO ACCEPT  
OTHER TYPES OF CONDUCTORS TO ACCEPT

**ATTENTION**  
UTILISER QUE DES CONDUCTEURS EN CUIVRE  
LES BRAMES DE L'UTILE NE SONT PAS CONSIDERES  
L'UTILISATION DE TOUT AUTRE CONDUCTEUR PEUT  
ENDOMMAGER L'EQUIPEMENT.

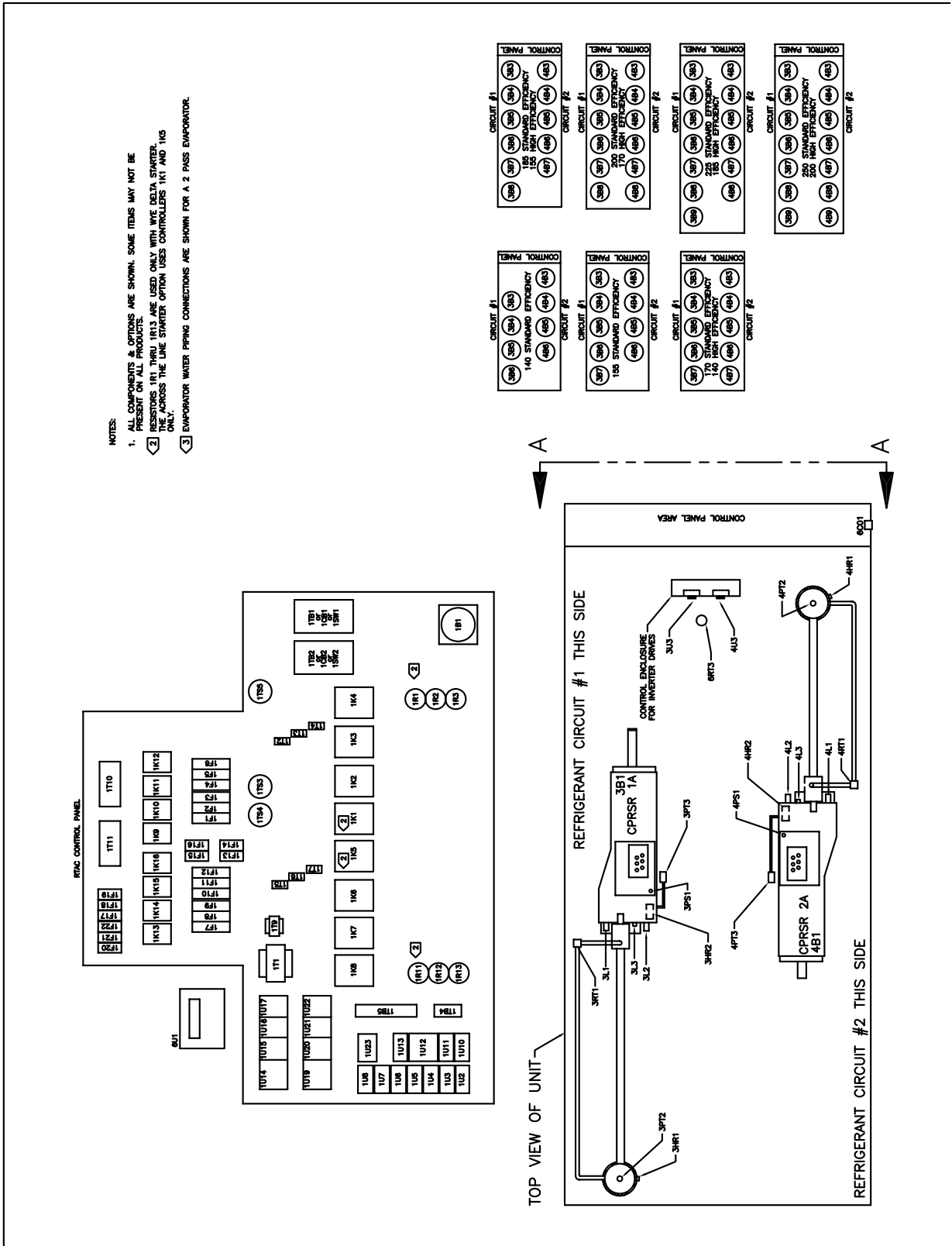
**PRECAUCION**  
UTILICE OROCAMENTE CONDUCTORES DE COBRE  
PUN ACEPTAR OTROS TIPOS DE CONDUCTORES.  
SI NO LO HACE, PUEDE COMENZAR DAÑO AL EQUIPO.

**WARNING**  
USE COPPER CONDUCTORS ONLY  
USE OTHER TYPES OF CONDUCTORS TO ACCEPT  
OTHER TYPES OF CONDUCTORS TO ACCEPT

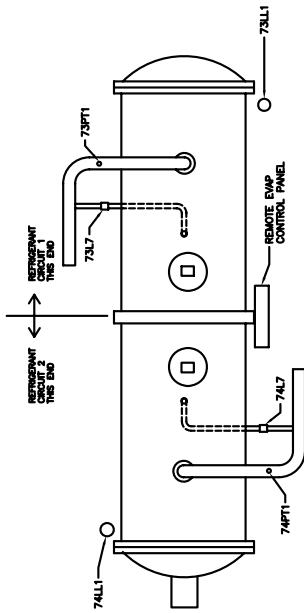


**WARNING**  
USE COPPER CONDUCTORS ONLY  
USE OTHER TYPES OF CONDUCTORS TO ACCEPT  
OTHER TYPES OF CONDUCTORS TO ACCEPT

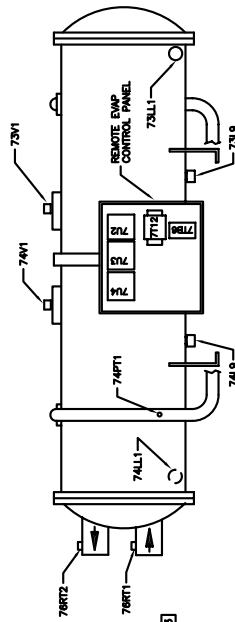




REPLACES 2309-2236	AUTOCAD THE TRANE COMPANY A DIVISION OF AMERSON STRONG INC.	2309-4872	REV B
REVISION DATE	DESIGNED BY 79L	COMPONENT LOCATION RTAC MEDIUM AIR COOLED 2 COMPRESSOR UNITS REMOTE EVAP	
DRAWN BY 79L	CHECKED BY 79L		
DATE 1-40-03	SCALE TO		



TOP  
VIEW  
OF  
EVAP



SIDE  
VIEW  
OF  
EVAP

## ⚠ WARNING

HAZARDOUS VOLTAGE!  
DISCONNECT ALL ELECTRIC POWER INCLUDING REMOTE DISCONNECTS AND FOLLOW LOCK OUT AND TAG PROCEDURES TO ALL ELECTRICAL PANELS. ALL MOTOR CAPACITORS MUST BE DISCHARGED. STORED VOLTAGE UNITS WITH VARIABLE SPEED DRIVE, REFER TO DRIVE INSTRUCTIONS FOR CAPACITOR DISCHARGE. FAILURE TO DO THE ABOVE BEFORE SERVICING COULD RESULT IN DEATH OR SERIOUS INJURY.

## ⚠ AVERTISSEMENT

TENSION DANGEREUSE!  
COUPER TOUTES LES TENSIONS ET OUVRIER LES SECTIONNEURS A DISTANCE. PUIS SUIVRE LES PROCÉDURES DE VERROUILLAGE ET DES ÉTIQUETTES AVANT TOUTE INTERVENTION. VÉRIFIER QUE TOUTS LES CONDENSATEURS DE MOTEUR SONT DÉCHARGÉS, DANS LE CAS D'UNITÉS À COMPORTANT DES ENTRAÎNEMENTS À VITESSE VARIABLE, SE REPORTER AUX INSTRUCTIONS DE L'ENTRAÎNEMENT POUR DÉCHARGER LES CONDENSATEURS. NE PAS RESPECTER CES MESURES DE PRÉCAUTION PEUT ENTRAÎNER DES BLESSURES GRAVES POUVANT ÊTRE MORTELLES.

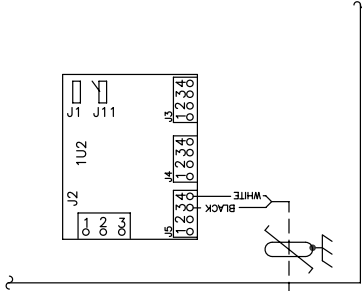
## ⚠ ADVERTENCIA

VOLTAJE PELIGROSO!  
DESCONECTE TODA LA ENERGÍA ELÉCTRICA, INCLUSO LAS DESCONECIONES REMOTAS Y SIGA LOS PROCEDIMIENTOS DE BLOQUEO Y ETIQUETADO DE TODOS LOS EQUIPOS DE SERVICIO. ASEGURESE DE QUE TODOS LOS CAPACITORES DEL MOTOR HAYAN DESCARGADO EL VOLTAJE ALMACENADO. PARA LAS UNIDADES CON EJE DE DIRECCIÓN DE VELOCIDAD VARIABLE, REFERIRSE A LAS INSTRUCCIONES PARA LA DESCARGA DEL CONDENSADOR. EL NO REALIZAR LO ANTERIORMENTE INDICADO, PODRÍA OCASIONAR LA MUERTE O SERIAS LESIONES PERSONALES.

REPLACES	AUTOCAD	2309-1974	REV. F
REVISION DATE	THIS TRAINER COMPANY	CUSTOMER FIELD CONNECTION	
3-11-02	A DIVISION OF AMERICAN STANDARD, INC. 10000 W. 10TH AVENUE, DENVER, CO 80202	RTAC	
DRAWN BY	AMERICAN STANDARD, INC. 10000 W. 10TH AVENUE, DENVER, CO 80202	2 COMPRESSOR UNITS	
PBL	SIMILAR TO	REMOTE EVAP	
DATE			
10-23-00			

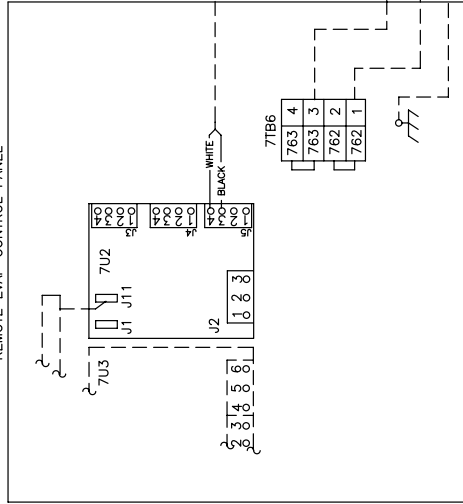
- NOTES:
- COMMUNICATION LINK TO BE SHIELDED, TWISTED PAIR LEADS. SHIELD TO BE GROUNDED ONLY AT THE MAIN UNIT CONTROL PANEL. THE LINK IS WIRED TO CIRCUIT BOARD MOUNTED BOX LUGS WITH A WIRE RANGE OF 14 TO 18 AWG. DO NOT RUN LOW VOLTAGE CONTROL WIRING (30 VOLTS OR LESS) IN CONDUIT WITH 110 VOLT OR HIGHER WIRING. DO NOT EXCEED THE FOLLOWING MAXIMUM RUN LENGTHS FOR A GIVEN SIZE: 14 AWG, 5000 FT; 16 AWG, 2000 FT; 18 AWG, 1000 FT.
  - ALL CUSTOMER CONTROL CIRCUIT WIRING MUST BE COPPER CONDUCTORS ONLY AND HAVE A MINIMUM INSULATION RATING OF 300 VOLTS. 115 VOLT POWER SUPPLY CONNECTIONS ARE MADE TO A TERMINAL STRIP WHICH HAS A #10 SET SCREW WHICH WILL ACCEPT RING OR FORK TERMINALS OR STRIPPED LEADS.

MAIN UNIT CONTROL PANEL



COMMUNICATION LINK

REMOTE EVAP CONTROL PANEL



CUSTOMER SUPPLIED  
115V 50/60HZ  
MAX FUSE SIZE  
15 AMPS

## CAUTION

USE COPPER CONDUCTORS ONLY!  
UNIT TERMINALS ARE NOT DESIGNED TO ACCEPT OTHER TYPES OF CONDUCTORS.  
FAILURE TO DO SO MAY CAUSE DAMAGE TO THE EQUIPMENT.

## ATTENTION

N'UTILISER QUE DES CONDUCTEURS EN CUIVRE!  
LES BORNES DE L'UNITÉ NE SONT PAS CONÇUES POUR RECEVOIR D'AUTRES TYPES DE CONDUCTEURS.  
L'UTILISATION DE TOUT AUTRE CONDUCTEUR PEUT ENDOMMAGER L'ÉQUIPEMENT.

## PRECAUCIÓN

¡UTILICE ÚNICAMENTE CONDUCTORES DE COBRE!  
LAS TERMINALES DE LA UNIDAD NO ESTÁN DISEÑADAS PARA ACEPTAR OTROS TIPOS DE CONDUCTORES.  
SI NO LO HACE, PUEDE OCASIONAR DAÑO AL EQUIPO.





**Trane**  
A business of American Standard Companies  
[www.trane.com](http://www.trane.com)

For more information contact your local district office or e-mail us at [comfort@trane.com](mailto:comfort@trane.com)

---

Literature Order Number	RTAC-SVX01F-EN
File Number	SV-RF-RTAC-SVX01F-EN-0106
Supersedes	RTAC-SVX01E-EN
Stocking Location	Inland

---

Trane has a policy of continuous product data and product improvement and reserves the right to change design and specifications without notice. Only qualified technicians should perform the installation and servicing of equipment referred to in this bulletin.