



MAXE™

Model YR

**Twin-Screw Compressor Liquid Chillers
Design Level A**



00562VIP



Rated in Accordance
with the latest edition of ARI
STANDARD 550/590

**200 through 430 tons (60 Hz)
700 through 1500 kW (50 Hz)
170 through 365 tons (50 Hz)
600 through 1280 kW (50 Hz)**

Utilizing HFC-134a



Metric Conversions

Table of Contents

	<u>PAGE</u>
INTRODUCTION.....	3
RATINGS	4
OPTIVIEW CONTROL CENTER	5
MECHANICAL SPECIFICATIONS	13
ACCESSORIES & MODIFICATIONS	17
SI METRIC CONVERSION	18
APPLICATION DATA.....	19
DIMENSIONS – STD.	26
Evaporator, Condenser & Water Boxes	26
Evaporators, Compact Water Boxes (ft.-in.)	28
Evaporators, Compact Water Boxes (mm)	29
Condensers, Compact Water Boxes (ft.-in.)	30
Condensers, Compact Water Boxes (mm)	31
Floor Layout, Neoprene Isolators (In.)	32
Floor Layout, Neoprene Isolators (mm)	33
Floor Layout, Spring Isolators (In. and mm)	34
WEIGHTS – Std. and Metric	35
GUIDE SPECIFICATIONS	36

LIST OF TABLES

<u>TABLE NO.</u>		<u>PAGE</u>
1	Water Flow Rate Limits	19
2	Motor Voltage Variations	22
3	60 Hz Electrical Data	23
4	Motor Starters	24
5	50 Hz Electrical Data	24
6	Available Compressor/Shell/ Motor Combinations	24

NOMENCLATURE

The model number denotes the following characteristics of the unit:

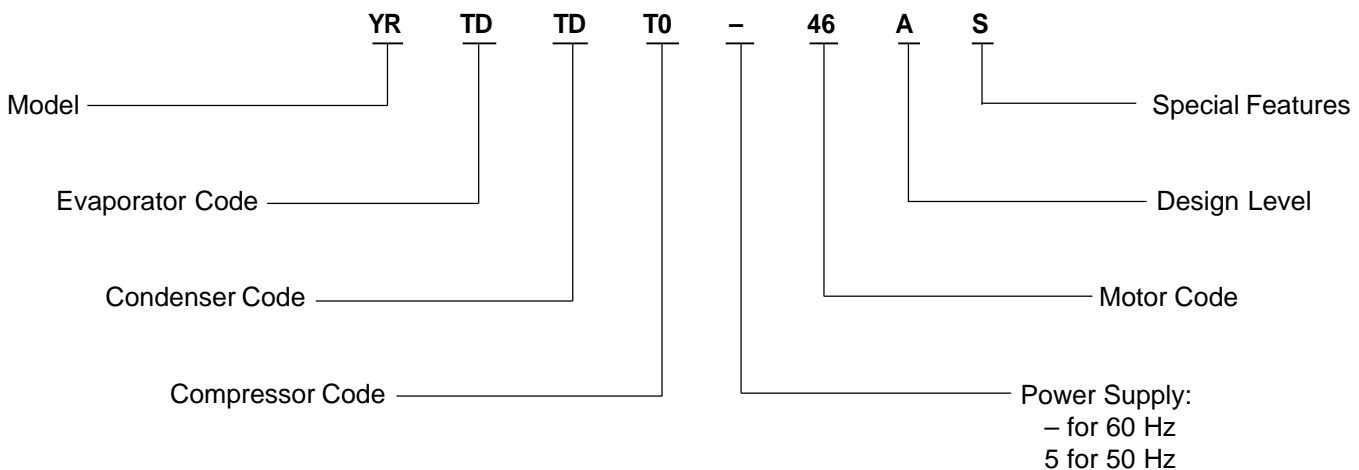

Introduction

The YORK MAXE YR Chiller offers a complete combination of features for total owner satisfaction.

MATCHED COMPONENTS MAXIMIZE EFFICIENCY

Actual chiller efficiency cannot be determined by analyzing the theoretical efficiency of any one chiller component. It requires a specific combination of heat exchanger, compressor, and motor performance to achieve the lowest system IPLV/NPLV. YORK MAXE chiller technology matches chiller system components to provide maximum chiller efficiency under actual – not just theoretical – operating conditions.

REAL-WORLD ENERGY PERFORMANCE

YORK pioneered the term “Real-World Energy” to illustrate the energy-saving potential of focusing on chiller performance during off-design conditions. Off-design is not only part-load, but full-load operation as well, with reduced entering condenser water temperatures (ECWTs). This is where chillers operate 99% of the time, and where operating costs add up.

The YR MAXE chillers are the only chillers designed to operate on a continuous basis with cold ECWT and full condenser flow at all load points, taking full advantage of Real-World conditions. This type of operation benefits the cooling tower as well; reducing cycling of the fan motor and ensuring good coverage of the cooling fill.

YORK MAXE chillers offer the most efficient Real-World operation of any chiller, meaning lower operating costs and an excellent return on your chiller investment.

HIGH-EFFICIENCY OIL SEPARATOR

MAXE YR Screw Chillers utilize high-efficiency oil separation, limiting oil carry-over to less than 500 ppm. Oil is vital in screw compressors for lubrication, rotor sealing and cooling. However, oil in the evaporator can lead to reduced heat transfer and reduced system performance. The high-efficiency oil separator keeps the oil in the lube circuit and maximizes heat transfer efficiency.

HIGH-EFFICIENCY HEAT EXCHANGERS

MAXE chiller heat exchangers offer the latest technology in heat transfer surface design to give you maximum efficiency and compact design. Waterside and refrigerant-side design enhancements minimize both energy consumption and tube fouling. The “skip-fin” design at all intermediate tube supports provides maximum tube wall thickness at the support area to extend tube life.

FACTORY PACKAGING REDUCES FIELD LABOR COSTS

YORK MAXE screw chillers are designed to keep installation costs low. Where installation access is not a problem, the unit can be shipped completely packaged, requiring minimal piping and wiring to complete the installation.

For those units utilizing a factory installed Solid-State Starter, the three power leads provide all power to the chiller and its auxiliaries.

TAKE ADVANTAGE OF COLDER COOLING TOWER WATER TEMPERATURES

YORK MAXE screw chillers are designed to take full advantage of colder cooling tower water temperatures, which are naturally available during most operating hours. Considerable energy savings are available by letting tower water temperature drop, rather than artificially holding it above 75°F (23.9°C), especially at low load, as some chillers require.

U.L. ACCEPTANCE – YOUR ASSURANCE OF RELIABILITY

YORK MAXE screw chillers are approved for listing by Underwriter’s Laboratories for the United States and Canada. Recognition of safety and reliability is your assurance of trouble-free performance in day-to-day building operation.

Ratings



Rated in accordance with the latest issue of ARI Standard 550/590.

ARI CERTIFICATION PROGRAM

The performance of YORK MAXE chillers is certified to the Air Conditioning and Refrigeration Institute (ARI) complying with the certification sections of the latest issue of ARI Standard 550/590. Under this Certification Program, chillers are regularly tested in strict compliance with this Standard. This provides an independent, third-party verification of chiller performance.

YORK YR screw chillers are designed to comply with ASHRAE Standard 90.1-1999 and 90.1-2001. The superior part-load performance of the YORK YR chillers far exceeds the IPLV/NPLV requirements of ASHRAE 90.1, providing superior Real World Energy savings for efficiency conscious owners.

COMPUTERIZED PERFORMANCE RATINGS

Each chiller is custom-matched to meet the individual building load and energy requirements. A large number of standard heat exchangers and pass arrangements are available to provide the best possible match.

It is not practical to provide tabulated performance for each combination, as the energy requirements at both

full- and part-load vary significantly with each heat exchanger and pass arrangement. Computerized ratings are available through each YORK sales office. These ratings can be tailored to specific job requirements, and are part of the ARI Certification Program.

OFF-DESIGN PERFORMANCE

Since the vast majority of its operating hours are spent at off-design conditions, a chiller should be chosen not only to meet the full-load design, but also for its ability to perform efficiently at lower loads and lower tower water temperatures. It is not uncommon for chillers with the same full-load kW/TON to have an operating cost difference of over 10% due to part-load operation.

Part-load information can be easily and accurately generated by computer. And because it is so important to an owner's operating budget, this information is now standard within the ARI Certification Program in the form of an Integrated Part-Load Value (IPLV), and Non-Standard Part-Load Value (NPLV).

The IPLV / NPLV formulas from ARI Standard 550/590 closely track chiller operations, and provide a more accurate indication of chiller performance than the previous IPLV / APLV formula. A more detailed analysis must take into account actual building load profiles, and local weather data. Part-load performance data should be obtained for each job using its own design criteria.

OptiView Control Center



OPTIVIEW CONTROL CENTER

The YORK OptiView Control Center, furnished as standard on each chiller, provides the ultimate in efficiency, monitoring, data recording, chiller protection and operating ease. The control center is a factory-mounted, wired and tested state-of-the-art microprocessor based control system for R-134a screw chillers. The panel is configured with a 10.4 inch diagonal color Liquid Crystal Display (LCD) surrounded by "soft" keys, which are redefined with one keystroke based on the screen display at that time. This revolutionary development makes chiller operation quicker and easier than ever before. Instead of requiring keystroke after keystroke to hunt for information on a small monochrome LCD screen, a single button reveals a wide array of information on a large, full-color illustration of the appropriate component, which makes information easier to interpret. This is all mounted in the middle of a keypad interface and installed in a locked enclosure.

The LCD display allows graphic animated display of the chiller, chiller sub-systems and system parameters; this allows the presentation of several operating parameters at once. In addition, the operator may view a graphical representation of the historical operation of the chiller as well as the present operation. A Status Bar is displayed at all times on all screens. It contains the System - Status Line and Details Line, the Control Source, Access Level, Date and Time.

During the Start Sequence and System Lockout Delay, the system status will include a countdown timer indicating the time remaining. The control panel is compatible with the YORK Solid State Starter (optional), Electro-mechanical (E-M) starter, or any customer supplied E-M starter that complies with the YORK R-1131 standard. The locations of various chiller parameters are clearly marked and instructions for specific operations are provided. The panel verbiage is available in other languages as an option, with English always available. Data can be displayed in either English or Metric units, plus keypad entry setpoints of 0.1 increments.

Security access is provided to prevent unauthorized change of setpoints. This is accomplished with three different levels of access and passwords for each level. There are screens, displayed values, programmable setpoints and manual controls only available with service level access to the chiller. They are only displayed when logged in at the service access level. The Advanced Diagnostics and troubleshooting information for the chiller and the panel is also included at this access level.

The panel is fused through a 1-1/2 KVA transformer in the compressor motor starter to provide individual over-current protected power for all controls. Numbered terminal strips for wiring such as Remote Start/Stop, Flow Switch, Chilled Water Pump and Local or Remote Cycling Device are provided. The Panel also provides field interlocks that indicate the chiller status. These con-

OptiView Control Center (continued)

tacts include a Remote Mode Ready To Start, a Cycling Shutdown, a Safety Shutdown and a chiller Run Contact. Pressure transducers sense system pressures and thermistors sense system temperatures. The output of each transducer is a DC voltage that is analogous to the pressure input. The output of each thermistor is a DC voltage that is analogous to the temperature it is sensing.

Setpoints can be changed from a remote location via 0-10VDC, 4-20mA, contact closures or through serial communications. The adjustable remote reset range [up to 20°F (11.1°C)] provides flexible, efficient use of remote signal depending on reset needs. Serial data interface to the YORK ISN Building Automation System (BAS) is through the General Protocol Interface Card (GPIC), which can be mounted inside the Control Center.

This printed circuit board requests the required data from the Micro Board and makes it available for the YORK ISN network. This optional board is available through the YORK BAS group. The operating program is stored in non-volatile memory (EPROM) to eliminate chiller failure due to AC power failure/battery discharge. Programmed setpoints are retained in lithium battery-backed RTC memory for 11 years minimum.

Smart Freeze Point Protection can operate the chiller as low as 36°F (2.22°C) leaving chilled water temperature, without nuisance trips on Low Water Temperature. The sophisticated program and sensor monitors the chiller water temperature to prevent freeze-up. Each programmable point has a pop-up screen with the allowable ranges, so the chiller cannot be programmed to operate outside of its design limits.

Thermal ice storage systems are based on the concept of using off-peak, lower cost electricity to build ice for handling the cooling load during peak hours. The most efficient way to build ice is to maximize chiller load and minimize run time. Standard chiller control systems are not designed for this operating mode. In a typical application, chillers will load and unload to maintain a leaving chilled liquid setpoint. When the YORK YR chiller operates in the thermal storage control mode, the unit will remain at 100% load until the setpoint shutdown temperature is reached. To add greater operating flexibility and eliminate unnecessary chiller cycling, two different Low Water (Liquid) Temperature Restart Thresholds can be programmed, one for the ice mode and one for the standard cooling mode. This control enhancement is standard on all YR chillers. The chiller can also be left in the standard control mode for temperatures ranging between 20 and 70°F (-6.7 and 21.1°C), for applications involving a process or comfort cooling duty that requires leaving chilled liquid temperature setpoint control.

When power is applied to the chiller, the **HOME** screen is displayed. This screen displays a visual representation of the chiller and a collection of data detailing important operations and parameters. When the chiller is running, the flow of chilled liquid is animated by the alternating shades of color moving in and out of the pipe nozzles. The primary values that need to be monitored and controlled are shown on this screen. They are as follows:

Display Only:

- Chilled Liquid Temperature – Leaving
- Chilled Liquid Temperature – Return
- Condenser Liquid Temperature – Return
- Condenser Liquid Temperature – Leaving
- Motor Run (LED)
- % Full-load Amps
- Operating Hours

With the “soft” keys the operator is only one touch away from the 8 main screens that allow access to the major information and components of the chiller. The 8 screens are the **SYSTEM, EVAPORATOR, CONDENSER, COMPRESSOR, OIL SUMP, MOTOR, SETPOINTS**, and the **HISTORY**. Also on the Home Screen is the ability to **Log IN, Log OUT** and **Print**. Log In and Log Out is the means by which different security levels are accessed.

The **SYSTEM** screen gives a general overview of common chiller parameters for both shells. This is an end view of the chiller with a 3-D cutaway of both the shells. The following can be viewed from this screen:

Display Only:

- Discharge Temperature
- Chilled Liquid Temperature – Leaving
- Chilled Liquid Temperature – Return
- Chilled Liquid Temperature – Setpoint
- Evaporator Pressure
- Evaporator Saturation Temperature
- Condenser Liquid Temperature – Leaving
- Condenser Liquid Temperature – Return
- Condenser Pressure
- Condenser Saturation Temperature
- Oil Temperature
- Differential Oil Pressure
- % Full-load Amps
- Current Limit
- Slide Valve Position

The **EVAPORATOR** screen displays a cutaway view of the chiller evaporator. All setpoints relating to the evaporator side of the chiller are maintained on this screen. Animation of the evaporation process indicates whether the chiller is presently in RUN condition (bubbling) and liquid flow in the pipes is indicated by alternating shades of color moving in and out of the pipes. Adjustable limits on the low water temperature setpoints allow the chiller to cycle on and off for greater efficiency and less chiller cycling. The chiller cycles off when the leaving chilled water temperature is below setpoint and is adjustable from 1°F (0.55°C) below to a minimum of 36°F (2.22°C). Restart is adjustable from setpoint up to a max. of 80°F (26.6°C). The Panel will check for flow to avoid freeze-up of the tubes. If flow is interrupted, shutdown will occur after a minimum of two seconds. The following can also be performed through this screen:

Display Only:

- Chilled Liquid Flow Switch (Open/Closed)
- Chilled Liquid Pump (Run/Stop)
- Evaporator Pressure
- Evaporator Saturation Temperature
- Return Chilled Liquid Temperature
- Leaving Chilled Liquid Temperature
- Evaporator Refrigerant Temperature
- Small Temperature Difference
- Leaving Chilled Liquid Temperature Setpoints – Setpoint
- Leaving Chilled Liquid Temperature Setpoints – Remote Range
- Leaving Chilled Liquid Temperature Setpoints – Shutdown
- Leaving Chilled Liquid Temperature Setpoints – Shutdown Offset
- Leaving Chilled Liquid Temperature Setpoints – Restart
- Leaving Chilled Liquid Temperature Setpoints – Restart Offset
- Ice Storage Active (LED)

Programmable:

- Local Leaving Chilled Liquid Temperature – Range
- Local Leaving Chilled Liquid Temperature – Setpoint
- Leaving Chilled Liquid Temperature Cycling Offset – Shutdown
- Leaving Chilled Liquid Temperature Cycling Offset – Restart

The **CONDENSER** screen displays a cutaway view of the chiller condenser. The liquid flow is animated to indicate flow through the condenser. All setpoints relating to the condenser side of the chiller are maintained on this screen. With the proper access level this screen also serves as a gateway to controlling the Refrigerant Level. The following can also be viewed through this screen:

Display Only:

- Leaving Condenser Liquid Temperature
- Return Condenser Liquid Temperature
- Condenser Pressure
- Condenser Saturation Temperature
- Small Temperature Difference
- High Pressure Switch (Open/Closed)
- Condenser Liquid Flow Switch
- Condenser Liquid Pump (Run/Stop)

Programmable:

- High Pressure Warning Threshold
- Freeze Warning (Enabled/Disabled)
- Freeze Time

The **COMPRESSOR** screen displays a cutaway view of the chiller compressor, revealing the rotary screw, and shows all conditions associated with the compressor. The slide valve positioning is animated and with the proper Access level, it can be manually controlled. Animation of the compressor rotors indicates whether the chiller is presently in a **RUN** condition. This screen also serves as a gateway to sub-screens for calibrating the slide valve or configuring the optional Hot Gas Bypass. From this screen you can view the following:

Display Only:

- Differential Oil Pressure
- Oil Temperature
- Discharge Temperature
- Discharge Superheat
- Slide Valve Position
- Oil Return Solenoid (LED)
- Full-load Amps (E.M. Starter Only)
- Phase A, B, C Current (SSS Only)

Programmable:

- Slide Valve Load (Manual)
- Slide Valve Hold (Manual)

OptiView Control Center (continued)

- Slide Valve Unload (Manual)
- Slide Valve Auto
- Max. Load Temperature
- Minimum Load FLA
- Minimum Load Control Source

The **HOT GAS BYPASS** screen, accessed from the COMPRESSOR screen, displays a pictorial of the bypass line and solenoid valve location on the chiller. The Hot Gas ON and OFF Setpoints are programmed on this screen and system parameters pertinent to Hot Gas Bypass operation are displayed. An LED illuminates when the Hot Gas solenoid is ON. If the chiller is equipped with the Hot Gas Bypass option, operation must be enabled on the OPERATIONS screen. From this screen you can perform the following:

Display Only:

- Slide Valve Position
- Return Chilled Liquid Temperature
- Leaving Chilled Liquid Temperature
- Hot Gas Solenoid (LED)

Programmable:

- On Setpoint
- Off Setpoint

The **SLIDE VALVE CALIBRATION** screen displays a cutaway view of the chiller compressor, revealing the rotary screw and slide valve and provides the capability of calibrating the slide valve. From this screen, you can perform the following:

Display Only:

- Slide Valve Loading (LED)
- Slide Valve Unloading (LED)
- Calibration Message

Programmable:

- Start Calibration
- Cancel Calibration

The **OIL SEPARATOR** screen displays a close-up view of the chiller oil separator/sump.

Display Only:

- Discharge Temperature
- Discharge Superheat
- Oil Pressure
- Discharge Pressure

- Differential Oil Pressure
- Differential Filter Pressure
- Oil Return Solenoid (LED)
- Evaporator Pressure
- Condenser Pressure
- Condenser Saturation

1. The **MOTOR** “soft” key on the HOME screen, when pressed, shows a picture of either a YORK Electro-Mechanical Starter or a Solid State Starter, depending on chiller configuration. The Programmable pulldown demand to automatically limit motor loading can be used to minimize building demand charges. Pulldown time period control over four hours, and verification of time remaining in pulldown cycle from display readout. Separate digital setpoint for current limiting between 30 and 100%.

The **ELECTRO-MECHANICAL STARTER (E-M)** screen displays a picture of the starter and the following values. The ones below are common among both offerings and the values will be displayed on both types of starter screens. From this screen you can perform the following:

Display Only:

- Motor Run (LED)
- Motor Current % Full-load Amps
- Current Limit Setpoints
- Pulldown Demand Time Left

Programmable:

- Local Motor Current Limit
- Pulldown Demand Limit
- Pulldown Demand Time

The **SOLID STATE STARTER (SSS)** screen displays a picture of the starter and the following values, which are displayed in addition to the common ones listed above. From this screen, you can perform the following:

Display Only:

- Input Power kW
- kW Hours
- Starter Model
- Voltage – Phase A, B, C
- Current – Phase A, B, C
- Temperature – Phase A, B, C

Programmable:

- Full-load Amps
- Voltage Range
- Starting Current
- Open SCR
- Shorted SCR
- kWh Reset

The **SETPOINTS** screen provides a convenient location for programming the most common setpoints involved in the chiller control. The Setpoints are shown on other individual screens, but to cut down on needless searching, they can all be found on this screen. This screen also serves as a gateway to a sub-screen for defining the setup of general system parameters. From this screen you can perform the following:

Display Only:

- Leaving Chilled Liquid Temperature – Setpoint
- Leaving Chilled Liquid Temperature Cycling – Shutdown
- Leaving Chilled Liquid Temperature Cycling – Restart
- Current Limit Setpoint

Programmable:

- Local Leaving Chilled Liquid Temperature – Range
- Local Leaving Chilled Liquid Temperature – Setpoint
- Leaving Chilled Liquid Temperature Cycling Offset – Shutdown
- Leaving Chilled Liquid Temperature Cycling Offset – Restart
- Remote Analog Input Range
- Local Motor Current Limit
- Pulldown Demand Limit
- Pulldown Demand Time
- Print

The **SETUP** is the top level of the general configuration parameters. It allows programming of the time and date, along with specifications as to how the time will be displayed. In addition, the chiller configuration as determined by the Micro Board program jumpers and program switches is displayed. From this screen you can perform the following:

Display Only:

- Chilled Liquid Pump Operation (Displays *Standard* or *Enhanced*)
- Anti-Recycle (Displays *Disabled* or *Enabled*)
- Power Failure Restart (Displays *Manual* or *Automatic*)
- Liquid Type (Displays *Water* or *Brine*)

Programmable:

- Set Date
- Set Time
- Clock (Enabled/Disabled)
- 12/24 Hour

The following six subscreens can be accessed from the SETUP screen:

The **SCHEDULE** screen contains more programmable values than a normal display screen. Each programmable value is not linked to a specific button; instead, the select key is used to enable the cursor arrows and check key to program the Start/Stop times for any day of the week up to **6 weeks** in advance. The user has the ability to define a standard set of Start/Stop times that are utilized every week or specify exceptions to create a special week.

Programmable:

- Exception Start/Stop Times
- Schedule (Enable/Disable)
- Repeat Sunday Schedule
- Standard Week Start/Stop Times
- Reset All Exception Days
- Select
- Print

OptiView Control Center (continued)

The **USER** screen allows definition of the language for the chiller to display and defines the unit of measure.

Programmable:

- System Language
- English/Metric Units

The **COMMS** screen allows the user to define communications parameters.

Programmable:

- Chiller ID
- COM 2 Baud Rate
- COM 2 Data Bit(s)
- COM 2 Parity Bit(s)
- COM 2 Stop Bit(s)
- Printer Baud Rate
- Printer Data Bit(s)
- Printer Parity Bit(s)
- Printer Stop Bit(s)

The **PRINTER** screen permits the user to define communications Parameters for the Printer.

Display Only

- Time Remaining Until Next Print

Programmable

- Log Start Time
- Output Interval
- Automatic Printer Logging (Enabled/Disabled)
- Print Type
- Print Report
- Print All Histories

The **SALES ORDER** screen allows definition of the order parameters. *Note: This information is loaded at the factory or by the installation service technician.*

Display Only

- Model Number
- Panel Serial Number
- Chiller Serial Number
- YORK Order Number
- System Information
- Condenser and Evaporator Design Load Information
- Nameplate Information

The **OPERATIONS** screen permits definition of parameters pertaining to operation of the chiller. What is defined is whether the control of the chiller will be Local, Digital Remote, Analog Remote, Modem Remote or ISN Remote.

Programmable

- Control Source

The **HISTORY** screen allows the user to browse through the last ten faults; either safety or cycling shutdowns with the conditions, while the chiller is running or stopped. The faults are color coded for ease in determining the severity at a glance, recording the date, time and description. (See Display Messages for Color Code meanings.)

Display Only

- Last Normal Shutdown
- Last Fault While Running
- Last Ten Faults

Programmable:

- Print History
- Print All Histories

By pressing the **VIEW DETAILS** key you will move to the **HISTORY DETAILS** screen. From these screens you are able to see an on-screen printout of all the system parameters at the time of the selected shutdown.

Display Only:

- History Printout

Programmable:

- Page Up
- Page Down
- Print History

Also under the **HISTORY** screen is the **TRENDING** screen, accessible by the key marked the same. On this screen, up to six operator-selected parameters, selected from a list of over 140, can be plotted in an X/Y graph format. The graph can be customized to record points once every second up to once every hour. There are two types of charts that can be created: single screen, or continuous screen. The single screen collects data for one screen width (450 data points across the X-axis), then stops. The continuous screen keeps

collecting the data, but the oldest data drops off the graph from left to right at the next data collection interval. For ease of identification, each plotted parameter, title and associated Y-axis labeling is color coordinated.

Display Only:

- This screen allows the user to view the graphical trending of the selected parameters and is a gateway to the graph setup screens.

Programmable:

- Start
- Stop
- y-axis
- x-axis

The **TREND SETUP** screen is used to configure the trending screen. The parameters to be trended are selected from the Trend Common Slots screen, accessed from the Slot Numbers button or the Master Slot Numbers List found in the Operating Manual. The interval at which all the parameters are sampled is selected under the Collection Interval button. The data point minimum and maximum values may be adjusted closer to increase viewing resolution.

Programmable:

- Chart Type (select *continuous* or *one screen*)
- Collection Interval
- Select
- Data Point Slot Number (1 - 6)
- Data Point Min. (1 - 6)
- Data Point Max (1 - 6)

The **TREND COMMON SLOTS** screen displays the Master Slot Numbers List of the monitored parameters.

Display Only:

- Slot Numbers

Programmable:

- Page Up
- Page Down
- Print

DISPLAY MESSAGES

The Control Center continuously monitors the operating system, displaying and recording the cause of any shutdowns (Safety, Cycling or Normal). The condition of the chiller is displayed at the System Status line that contains a message describing the operating state of the chiller; whether it is stopped, running, starting or shutting down. A System Details Line displays Warning, Cycling, Safety, Start Inhibit and other messages that provide further details of the Status Bar messages. Messages are color-coded: Green – Normal Operations; Yellow – Warnings; Orange – Cycling Shutdowns; and Red – Safety Shutdowns to aid in identifying problems quickly.

Status messages include:

- System Ready To Start
- Cycling Shutdown – Auto Restart
- Safety Shutdown – Manual Restart
- Start Sequence Initiated
- System Run (with countdown timers)
- Start Inhibit
- Slide Valve Closing Before Shutdown
- System Lockout Delay

Run Messages include:

- Leaving Chilled Liquid Control
- Motor Pulldown Limit
- Motor – High Current Limit

Start Inhibit Messages include:

- Anti-Recycle XX min/sec.
- Slide Valve – Position >30%
- Motor Current >15% FLA
- LCSSS – High-Temperature Phase X - Stopped

Warning Messages include:

- Real Time Clock Failure
- Setpoint Override
- Condenser – High Pressure Limit
- Evaporator – Low Pressure Limit
- Freeze Threat From Operating Chiller
- Freeze Threat, Condenser Flow Switch Open
- Low Discharge Superheat Limit

OptiView Control Center (continued)

- Low Discharge Superheat Detected
- Maximum Load – Load Limit
- Minimum Load – Load Limit
- Oil – Dirty Filter
- Oil – High Temperature
- Slide Valve Uncalibrated

Routine Shutdown Messages Include:

- Remote Stop
- Local Stop
- Place Compressor Switch In Run Position

Cycling Shutdown Messages Include:

- Multiunit Cycling – Contacts Open
- System Cycling – Contacts Open
- Control Panel – Power Failure
- Leaving Chilled Liquid – Low Temperature
- Leaving Chilled Liquid – Flow Switch Open
- Condenser – Flow Switch Open
- Motor Controller – Contacts Open
- Motor Controller – Loss of Current
- Power Fault
- Control Panel – Schedule

Solid State Starter Only (LCSSS)

- Initialization Failed
- Serial Communications
- Requesting Fault Data
- Stop Contacts Open
- Power Fault
- Low Phase (X) Temperature Sensor
- Run Signal
- Invalid Current Scale Selection

- Phase Locked Loop
- Low Supply Line Voltage
- High Supply Line Voltage
- Logic Board Processor
- Logic Board Power Supply
- Phase Loss

Safety Shutdown Messages include:

- Evaporator – Low Pressure
- Evaporator – Low Pressure – Smart Freeze
- Evaporator – Transducer or Leaving Liquid Probe
- Evaporator – Transducer or Temperature Sensor
- Condenser – High Pressure Contacts Open
- Condenser – High Pressure
- Condenser – Pressure Transducer Out of Range
- Auxiliary Safety – Contacts Closed
- Discharge – High Temperature
- Discharge – Low Temperature
- Oil – Low Differential Pressure
- Oil or Condenser Transducer Error
- Oil – Clogged Filter
- Oil – High Pressure
- Control Panel – Power Failure
- Watchdog – Software Reboot

Solid State Starter Only (LCSSS)

- Shutdown – Requesting Fault Data . . .
- High Instantaneous Current
- High Phase (X) Heatsink Temperature – Running
- 105% Motor Current Overload
- Motor or Starter – Current Imbalance
- Open SCR
- Phase Rotation

Mechanical Specifications

GENERAL

Each YORK MaxE YR Screw Chiller will be completely factory-packaged including evaporator, condenser, compressor, motor, OptiView control center and all interconnecting unit piping and wiring. The chiller will be painted prior to shipment and will be packaged to protect the unit during shipment.

Performance will be certified in accordance with ARI Standard 550/590.

The initial charge of refrigerant and oil will be supplied for each unit.

DRIVELINE

The compressor will be twin-screw, rotary-screw type. The compressor housing will be of cast iron, precision machined to provide minimal clearance for the rotors. The rotors will be manufactured from forged steel and use asymmetric profiles operating at a maximum speed of 3570 RPM (60 Hz) or 2975 RPM (50 Hz). The compressor will incorporate a complete anti-friction bearing design to reduce power and increase reliability; cylindrical roller bearings to handle radial loads; and 4 point angular contact ball bearings to handle axial loads. The compressor will have an internal oil reservoir to assure a constant supply of oil to the bearings at all times. A check valve will be incorporated in the compressor housing to prevent rotor backspin during shutdown.

Capacity control will be achieved by use of a slide valve to provide fully modulating control from 100% to 20% of full-load. The slide valve will be actuated by system differential pressure, controlled by external solenoid valves through the OptiView control center. The unit will be capable of operating with off-design cooling tower water during part-load operation in accordance with ARI Standard 550/590.

The motor will be 2-pole, continuous-duty, cage-induction type, and will utilize suction gas cooling (semi-hermetic design). Motor full-load amperes at design conditions will not exceed chiller nameplate (FLA). Motor will be designed for use with the type starter specified.

LUBRICATION SYSTEM

An adequate supply of oil will be available to the compressor at all times. During operation, oil will be delivered by positive system pressure differential.

An immersion oil heater will be provided, (temperature actuated), to effectively remove refrigerant from the oil during the chiller off-cycle. An external, replaceable cartridge, oil filter will be provided, along with manual isolation

stop valves for ease of servicing. An oil eductor will be provided to automatically remove oil which may have migrated to the evaporator, and return it to the compressor. The oil separator will be of a vertical design with no moving parts, and will provide high-efficiency oil separation before the refrigerant enters the heat exchangers. The oil separator will be designed, tested, and stamped in accordance with the ASME Boiler and Pressure Vessel Code, Section VIII Division 1. Liquid refrigerant injection will be provided to maintain satisfactory oil temperatures and allow operation of the chiller over the full range of conditions.

EVAPORATOR

Evaporator will be of the shell-and-tube, flooded type designed for 235 PSIG (1620 kPa) working pressure on the refrigerant side, and will be tested in accordance with ASME code. The shell will be fabricated from rolled carbon steel plate with fusion welded seams or carbon steel pipe; have carbon steel tube sheets, drilled and reamed to accommodate the tubes; and intermediate tube supports spaced no more than four feet apart. The refrigerant side will be designed, tested and stamped in accordance with the ASME Boiler and Pressure Vessel Code, Section VIII Division 1. Tubes shall be high-efficiency, internally and externally enhanced type having plain copper lands at all intermediate tube supports to provide maximum tube wall thickness at the support area. Each tube will be roller expanded into the tube sheets providing a leak-proof seal, and be individually replaceable. Water velocity through the tubes will not exceed 12 fps. A liquid level sight glass will be located on the side of the shell to aid in determining proper refrigerant charge. The evaporator will have a refrigerant relief device to meet the requirements of the ASHRAE 15 Safety Code for Mechanical Refrigeration.

Water boxes will be removable to permit tube cleaning and replacement. Stubout water connections having victaulic grooves will be provided. Vent and drain connections with plugs will be provided on each water box.

CONDENSER

Condenser will be of the shell-and-tube type, designed for 235 psig (1620 kPa) working pressure on the refrigerant side, and be tested in accordance with ASME code. The shell will be fabricated from rolled carbon steel plate with fusion welded seams or carbon steel pipe; have carbon steel tube sheets, drilled and reamed to accommodate the tubes; and intermediate tube supports spaced no more than four feet apart. A refrigerant subcooler will be provided for improved cycle efficiency. The refrigerant side will be designed, tested and stamped in accordance with the ASME Boiler and Pres-

Mechanical Specifications (continued)

sure Vessel Code, Section VIII, Division 1. Tubes shall be high-efficiency, internally and externally enhanced type having plain copper lands at all intermediate tube supports to provide maximum tube wall thickness at the support area. Each tube will be roller expanded into the tube sheets providing a leak proof seal, and be individually replaceable. Water velocity through the tubes will not exceed 12 fps. The condenser will have refrigerant relief devices to meet the requirements of the ASHRAE 15 Safety Code for Mechanical Refrigeration.

Water boxes will be removable to permit tube cleaning and replacement. Stubout water connections having victaulic grooves will be provided. Vent and drain connections with plugs will be provided on each water box.

REFRIGERANT SYSTEM

A modulating variable orifice controlled by the OptiView Control Center to accommodate varying head conditions will meter refrigerant flow to the evaporator.

The condenser shell will be capable of storing the entire system refrigerant charge during servicing. Service valves will be provided to facilitate removal of refrigerant charge from the system.

The unit will be equipped with a suction strainer to prevent any foreign debris introduced to the system during maintenance or service to be allowed into the motor housing. Motors cooled by refrigerant must be protected by means of filter or strainer to protect the motor and prolong motor life.

OPTIVIEW CONTROL CENTER

General

The chiller will be controlled by a stand-alone micro-processor based control center. The chiller control panel will provide control of chiller operation and monitoring of chiller sensors, actuators, relays and switches.

Control Panel

The control panel will include a 10.4 inch diagonal color liquid crystal display (LCD) surrounded by "soft " keys which are redefined based on the screen displayed at that time. It will be mounted in the middle of a keypad interface and installed in a locked enclosure. The screen will detail all operations and parameters, using a graphical representation of the chiller and its major components. Panel verbiage is available in other languages as an option with English always available. Data can be displayed in either English or Metric units. Smart Freeze Point Protection will run the chiller at 36 °F (2.2°C) leav-

ing chilled water temperature, and not have nuisance trips on low water temperature. The sophisticated program and sensor will monitor the chiller water temperature to prevent freeze up. When needed, Hot Gas Bypass is available as an option. The panel displays countdown timer messages so the operator knows when functions are starting and stopping. Every programmable point will have a pop-up screen with the allowable ranges, so that the chiller can not be programmed to operate outside of its design limits.

The control panel is provided with a thermal ice storage control mode to enhance system performance during ice building operation. In the thermal storage control mode, the chiller will stay at 100% load until the setpoint shutdown temperature is reached. To add greater operating flexibility and eliminate unnecessary chiller cycling, two different Low Water (Liquid) Temperature Restart Thresholds are programmable, one for the ice mode and one for the standard cooling mode. The chiller has the capability to remain in the standard control mode for temperatures between 20 to 70°F (-6.6 to 21.1°C) for applications involving a process or comfort cooling duty that requires leaving chilled liquid temperature setpoint control.

The chiller control panel also provides:

1. System operating information including:
 - a. return and leaving chilled liquid temperature
 - b. return and leaving condenser liquid temperature
 - c. evaporator and condenser saturation temperature
 - d. oil pressure at compressor and oil filter differential
 - e. percent motor current
 - f. evaporator and condenser saturation temperature
 - g. compressor discharge temperature
 - h. oil temperature
 - i. percent slide valve position
 - j. operating hours
 - k. number of unit starts
2. Digital programming of setpoints through the universal keypad including:
 - a. leaving chilled liquid temperature
 - b. percent current limit
 - c. pull-down demand limiting
 - d. six-week schedule for starting and stopping the chiller, pumps and tower
 - e. remote reset temperature range

3. Status messages indicating:
 - a. system ready to start
 - b. system running
 - c. system coastdown
 - d. system safety shutdown-manual restart
 - e. system cycling shutdown-auto restart
 - f. start sequence initiated
 - g. start inhibit
4. The text displayed within the system status and system details field will be displayed as a color coded message to indicate severity: red for safety fault, orange for cycling faults, yellow for warnings, and green for normal messages.
5. Safety shutdowns enunciated through the display and the status bar, and consist of system status, system details, day, time, cause of shutdown, and type of restart required. Safety shutdowns with a fixed speed drive will include:
 - a. evaporator – low pressure
 - b. evaporator – low pressure – smart freeze
 - c. evaporator – transducer or leaving liquid probe
 - d. evaporator – transducer or temperature sensor
 - e. condenser – high pressure contacts open
 - f. condenser – high pressure
 - g. condenser – pressure transducer out of range
 - h. auxiliary safety – contacts closed
 - i. discharge – high temperature
 - j. discharge – low temperature
 - k. oil – low differential pressure
 - l. oil or condenser transducer error
 - m. oil – clogged filter
 - n. oil – high pressure
 - o. control panel – power failure
 - p. watchdog – software reboot
- 5.1. Safety shutdowns with a Solid State Starter (LCSSS) will include:
 - a. shutdown – requesting fault data...
 - b. high instantaneous current
 - c. high phase (X) heatsink temperature - running
 - d. 105% motor current overload
 - e. motor or starter – current imbalance
 - f. phase (X) shorted SCR
 - g. open SCR
 - h. phase rotation
6. Cycling shutdowns enunciated through the display and the status bar, and consists of system status, system details, day, time, cause of shutdown, and type of restart required. Cycling shutdowns with a fixed speed drive will include:
 - a. multiunit cycling – contacts open
 - b. system cycling - contacts open
 - c. control panel - power failure
 - d. leaving chilled liquid - low temperature
 - e. leaving chilled liquid - flow switch open
 - f. condenser – flow switch open
 - g. motor controller – contacts open
 - h. motor controller – loss of current
 - i. power fault
 - j. control panel - schedule
- 6.1. Cycling shutdowns with a Solid State Starter (LCSSS) will include:
 - a. initialization failed
 - b. serial communications
 - c. requesting fault data
 - d. stop contacts open
 - e. power fault
 - f. low phase (X) temperature sensor
 - g. run signal
 - h. invalid current scale selection
 - i. phase locked loop
 - j. low supply line voltage
 - k. high supply line voltage
 - l. logic board processor
 - m. logic board power supply
 - n. phase loss
7. Security access to prevent unauthorized change of setpoints, to allow local or remote control of the chiller, and to allow manual operation of the slide valve. Access is through ID and password recognition, which is defined by three different levels of user competence: view, operator, and service.
8. Trending data with the ability to customize points of once every second to once every hour. The panel shall trend up to 6 different parameters from a list of over 140, without the need of an external monitoring system.
9. The operating program stored in non-volatile memory (EPROM) to eliminate reprogramming the chiller due to AC power failure or battery discharge. Programmed setpoints will be retained in lithium battery-backed RTC memory for a minimum of 11 years with power removed from the system.
10. A fused connection through a transformer in the compressor motor starter to provide individual over-current protected power for all controls.

Mechanical Specifications (continued)

11. A numbered terminal strip for all required field interlock wiring.
12. An RS-232 port to output all system operating data, shutdown / cycling message, and a record of the last 10 cycling or safety shutdowns to a field-supplied printer. Data logs to a printer at a set programmable interval. This data can be preprogrammed to print from 1 minute to 1 day.
13. The capability to interface with a building automation system to provide:
 - a. remote chiller start and stop
 - b. remote leaving chiller liquid temperature adjust
 - c. remote current limit setpoint adjust
 - d. remote ready to start contacts
 - e. safety shutdown contacts
 - f. cycling shutdown contacts
 - g. run contacts

STARTUP AND OPERATOR TRAINING

The services of a factory-trained, field service representative will be provided to supervise the initial startup and conduct concurrent operator instruction.

CODES AND STANDARDS

- ASME Boiler and Pressure Vessel Code – Section VIII Division 1.
- ARI Standard 550/590
- c/U.L. – Underwriters Laboratory
- ASHRAE 15 – Safety Code for Mechanical Refrigeration
- ASHRAE Guideline 3 – Reducing Emission of Halogenated Refrigerants in Refrigeration and Air-Conditioning Equipment and Systems
- NEC – National Electrical Code
- OSHA – Occupational Safety and Health Act

ISOLATION MOUNTING

The unit is provided with four vibration isolation mounts consisting of 1" (25.4 mm) thick neoprene isolation pads for field mounting under the steel mounting pads located on the tube sheets.

REFRIGERANT CONTAINMENT

The standard unit has been designed as a complete and compact factory packaged chiller. As such, it has minimum joints from which refrigerant can leak. The entire assembly has been thoroughly leak tested at the factory prior to shipment. The YORK chiller includes service valves conveniently located to facilitate transfer of refrigerant to a remote refrigerant storage/recycling system. Optional condenser isolation valves permit storage of the charge in the condenser.

PAINT

Exterior surfaces are protected with one coat of Caribbean blue, durable alkyd-modified, vinyl enamel, machinery paint.

SHIPMENT

The unit shall be completely assembled, with all main, auxiliary, and control piping installed, controls wired, leak tests completed, functional run tests completed, and refrigerant charge in place. The oil charge, relief device and other miscellaneous materials shall be packed separately.

Protective covering is furnished on the Control Center and unit-mounted controls. The entire unit is then shrink-wrapped with high-quality reinforced plastic to provide maximum protection during transit. Water nozzles are capped with fitted plastic enclosures.

Accessories and Modifications

SOLID STATE STARTER

The Solid State Starter is a reduced voltage starter that controls and maintains a constant current flow to the motor during startup. It is compact and mounted on the chiller at the motor terminals. Power and control wiring is factory supplied. Available for 200-600 volts, the starter enclosure is NEMA-1 with a hinged access door with lock and key. Electrical lugs for incoming power wiring are provided.

Standard features include: digital readout at the OptiView Control Center of the following:

Display Only:

- 3-phase voltage A, B, C
- 3-phase current A, B, C
- Input power (kW)
- kW Hours
- Starter Model
- Motor Run (LED)
- Motor Current % Full-load Amps
- Current Limit Setpoints
- Pulldown Demand Time Left

Programmable:

- Local Motor Current Limit
- Pulldown Demand Limit
- Pulldown Demand Time

Other features include: low line voltage; 115-volt control transformer; three-leg sensing overloads; phase rotation and single-phase failure protection; high temperature safety protection; motor current imbalance and undervoltage safeties; open and close SCR protection; momentary power interruption protection. The LCSSS is cooled by a closed-loop, fresh water circuit consisting of a water-to-water heat exchanger and 1/25 HP circulating pump. All interconnecting water piping is factory installed and rated for 150 PSIG working pressure. **Optional** unit-mounted circuit breaker includes ground fault protection and provides 65,000 amp short-circuit withstand rating in accordance with UL Standard 508. A non-fused disconnect switch is also available. Both options are padlockable.

BAS REMOTE CONTROL

A communication interface permitting complete exchange of chiller data with any BAS system is available with optional ISN translator. ISN translator also allows BAS system to issue commands to the chiller to control its operation. ISN translators come in two models, controlling up to four chillers and eight chillers respectively.

FACTORY INSULATION OF EVAPORATOR

Factory-applied thermal insulation of the flexible, closed-cell plastic type, 3/4" (19mm) thick is attached with vapor-proof cement to the evaporator shell, flow chamber, evaporator tube sheets, suction connection, and (as necessary) to the auxiliary tubing. Not included is the insulation of water boxes and nozzles. This insulation will normally prevent condensation in environments with relative humidities up to 75% and dry bulb temperatures ranging from 50° to 90°F (10° to 32°C). 1-1/2" (38mm) thick insulation is also available for relative humidities up to 90% and dry bulb temperatures ranging from 50° to 90°F (10° to 32°C).

WATER FLANGES

Four 150 lb. ANSI raised-face flanges, for condenser and evaporator water connections, are factory welded to water nozzles. Companion flanges, bolts, nuts and gaskets are not included.

SPRING ISOLATION MOUNTING

Spring Isolation mounting is available instead of standard isolation mounting pads when desired. Four level-adjusting/spring-type vibration isolator assemblies with non-skid pads are provided with mounting brackets for field installation. Isolators are designed for one-inch (25.4 mm) deflection.

WATER FLOW SWITCHES

Paddle-type, vapor-proof water flow switches suitable for 150 psig (1034 kPa) DWP for chilled and condenser water circuits. Switch for 115V-1-50/60 Hz service. A chilled water flow switch is required. Condenser water flow switch is optional.

SEQUENCE CONTROL KIT

For two, three or four units with chilled water circuits connected in series or parallel, the kit consists of return water thermostat, lead-lag selector switch for sequence starting, and time delay relay, with NEMA-1 enclosures, designed for 115V-1-50/60 Hz.

STARTER – FIELD INSTALLED

A field installed, electro-mechanical compressor motor starter is available, selected for proper size and type for job requirements and in accordance with YORK Engineering Standard R-1131 for Starters.

Accessories and Modifications (continued)

MARINE WATER BOXES

Marine water boxes allow service access for cleaning of the heat exchanger tubes without the need to break the water piping. Bolted-on covers are arranged for convenient access. Victaulic nozzle connections are standard; flanges are optional. Marine water boxes are available for condenser and/or evaporator.

KNOCK-DOWN SHIPMENT

The chiller can be shipped knocked-down into major assemblies (evaporator, condenser, driveline, etc.) as

required to rig into tight spaces. This is particularly convenient for existing buildings where equipment room access does not allow rigging a factory packaged chiller.

REFRIGERANT STORAGE/RECYCLING SYSTEM

A refrigerant storage/recycling system is a self-contained package consisting of a refrigerant compressor with oil separator, storage receiver, water-cooled condenser, filter drier and necessary valves and hoses to remove, replace and distill refrigerant. All necessary controls and safety devices are a permanent part of the system. Typically not required if unit isolation valves are provided.

SI Metric Conversion

The following factors can be used to convert from English to the most common SI Metric values.

MEASUREMENT	MULTIPLY THIS ENGLISH VALUE	BY	TO OBTAIN THIS METRIC VALUE
CAPACITY	TONS REFRIGERANT EFFECT (ton)	3.516	KILOWATTS (kW)
POWER	KILOWATTS (kW)	NO CHANGE	KILOWATTS (kW)
	HORSEPOWER (hp)	0.7457	KILOWATTS (kW)
FLOW RATE	GALLONS / MINUTE (gpm)	0.0631	LITERS / SECOND (L/s)
LENGTH	FEET (ft)	304.8	MILLIMETERS (mm)
	INCHES (in)	25.4	MILLIMETERS (mm)
WEIGHT	POUNDS (lb)	0.4536	KILOGRAMS (kg)
VELOCITY	FEET / SECOND (fps)	0.3048	METERS / SECOND (m/s)
PRESSURE DROP	FEET OF WATER (ft)	2.989	KILOPASCALS (k Pa)
	POUNDS / SQ. INCH (psi)	6.895	KILOPASCALS (k Pa)

Integrated Part Load Value (IPLV)

In the English I-P system, IPLV is calculated by the following formula. A full explanation is shown on page 4:

$$IPLV^* = \frac{1}{\frac{0.01}{A} + \frac{0.42}{B} + \frac{0.45}{C} + \frac{0.12}{D}}$$

Where: A = kW / ton at 100% Load @ 85°F ECFT
 B = kW / ton at 75% Load @ 75°F ECFT
 C = kW / ton at 50% Load @ 65°F ECFT
 D = kW / ton at 25% Load @ 65°F ECFT

In SI Metric, the formula is:

$$IPLV^* = 0.01A + 0.42B + 0.45C + 0.12D$$

Where: A = COP at 100% Load @ 29.4°C ECFT
 B = COP at 75% Load @ 23.9°C ECFT
 C = COP at 50% Load @ 18.3°C ECFT
 D = COP at 25% Load @ 18.3°C ECFT

NOTE:

* The Non-Standard Part-Load Value (NPLV) uses the IPLV formula with the following exceptions: the ECFT for part-load points varies linearly from the selected EFT to 65°F (18.3°C) from 100% to 50% loads, and fixed at 65°F (18.3°C) for 50% to 0% loads.

Application Data

The following is a user's guide in the application and installation of MAXE Chillers, and will ensure the reliability and trouble-free life for which this equipment was designed. While this guide is directed towards normal, water-chilling applications, the YORK sales representatives can provide complete recommendations on other types of applications.

Location

MAXE Chillers are virtually vibration-free and generally can be located at any level in a building where the construction will support the total system operating weight.

The unit site must be a floor, mounting pad or foundation which is level within 1/4" (6.4 mm) and capable of supporting the operating weight of the chiller.

Sufficient clearance to permit normal service and maintenance work should be provided all around and above the unit. Additional space should be provided at one end of the unit to permit cleaning of evaporator and condenser tubes as required. A doorway or other properly located opening may be used.

The chiller should be installed in an indoor location where temperatures range from 40°F to 110°F (4.4°C to 43.3°C).

Water Circuits

Flow Rate – For normal water chilling duty, evaporator flow rates are permitted at water velocity levels in the heat exchangers tubes of between 3 ft./second and 12 ft./second (0.91 m/s and 3.66 m/s). Condenser flow rates are permitted between 3.33 ft./sec. and 12 ft./sec. (1.01 m/s and 3.66 m/s). Variable flow applications are possible, and initial chiller selections should be made accordingly to permit proper range of flow while maintaining the mini-

imum velocity noted above. Variable flow in the condenser is not recommended, as it generally raises the energy consumption of the system by keeping the condenser pressure high in the chiller. Additionally, the rate of fouling in the condenser will increase at lower water velocities associated with variable flow, raising system maintenance costs. Cooling towers typically have narrow ranges of operation with respect to flow rates, and will be more effective with full design flow. Ref. Table 1 for flow limits.

Temperature Ranges – For normal water chilling duty, leaving chilled water temperatures may be selected between 38°F (3.3°C) [36°F (2.2°C) with Smart Freeze enabled) and 70°F (21.1°C) for water temperature ranges between 3°F and 30°F (1.7°C and 16.7°C).

Water Quality – The practical and economical application of liquid chillers requires that the quality of the water supply for the condenser and evaporator be analyzed by a water treatment specialist. Water quality may affect the performance of any chiller through corrosion, deposition of heat-resistant scale, or sedimentation or organic growth. These will degrade chiller performance and increase operating and maintenance costs. Normally, performance may be maintained by corrective water treatment and periodic cleaning of tubes. If water conditions exist which cannot be corrected by proper water treatment, it may be necessary to provide a larger allowance for fouling, and/or to specify special materials of construction.

General Piping – All chilled water and condenser water piping should be designed and installed in accordance with accepted piping practice. Chilled water and condenser water pumps should be located to discharge through the chiller to assure positive pressure and flow through the unit. Piping should include offsets to provide flexibility and should be arranged to prevent drainage of water from the

TABLE 1 – WATER FLOW RATE LIMITS – GPM (L/s)

SHELL CODE	PASS	EVAPORATOR		CONDENSER	
		MINIMUM	MAXIMUM	MINIMUM	MAXIMUM
TB, VB	1	383 (24.2)	1525 (96.2)	613 (38.7)	2204 (139.1)
	2	192 (12.1)	762 (48.1)	307 (19.4)	1102 (69.5)
	3	128 (8.1)	508 (32.1)	205 (12.9)	734 (46.3)
TC, VC	1	468 (29.5)	1866 (118.0)	683 (43.1)	2455 (154.9)
	2	234 (14.8)	932 (58.8)	342 (21.6)	1227 (77.4)
	3	157 (9.9)	621 (39.2)	228 (14.4)	818 (51.6)
TD, VD	1	570 (36.0)	2277 (143.7)	771 (48.7)	2774 (175.0)
	2	286 (18.0)	1138 (71.8)	386 (24.4)	1386 (87.5)
	3	—	—	—	—
WB, XB	1	693 (43.7)	2771 (174.9)	866 (54.6)	3462 (218.5)
	2	346 (21.8)	1385 (87.4)	433 (27.3)	1731 (109.2)
	3	231 (14.6)	924 (58.3)	289 (18.2)	1154 (72.8)
WC, XC	1	822 (51.9)	3287 (207.4)	1082 (68.3)	4328 (273.1)
	2	411 (25.9)	1644 (103.7)	541 (34.1)	2164 (136.5)
	3	274 (17.3)	1096 (69.2)	361 (22.8)	1443 (91.1)
WD, XD	1	986 (62.2)	3945 (248.9)	1350 (85.2)	5400 (340.1)
	2	493 (31.1)	1972 (124.4)	675 (42.6)	2700 (170.0)
	3	—	—	—	—

Application Data (continued)

evaporator and condenser when the pumps are shut off. Piping should be adequately supported and braced independently of the chiller to avoid the imposition of strain on chiller components. Hangers must allow for alignment of the pipe. Isolators in the piping and in the hangers are highly desirable in achieving sound and vibration control.

Convenience Considerations – To facilitate the performance of routine maintenance work, some or all of the following steps may be taken by the purchaser. Evaporator and condenser water boxes are equipped with plugged vent and drain connections. If desired, vent and drain valves may be installed with or without piping to an open drain. Pressure gauges with stop cocks, and stop valves, may be installed in the inlets and outlets of the condenser and chilled water line as close as possible to the chiller. An overhead monorail or beam may be used to facilitate servicing.

Connections – The standard chiller is designed for 150 psig (1034 kPa) design working pressure in both the chilled water and condenser water circuits. The connections (water nozzles) to these circuits are furnished with grooves for Victaulic couplings. Piping should be arranged for ease of disassembly at the unit for tube cleaning. All water piping should be thoroughly cleaned of all dirt and debris before final connections are made to the chiller.

Chilled Water – A flow switch must be installed in the chilled water line of every unit. The switch must be located in the horizontal piping close to the unit, where the straight horizontal runs on each side of the flow switch are at least five pipe diameters in length. The switch must be electrically connected to the chilled water interlock position in the unit control center. A water strainer of maximum 1/8" (3.2 mm) perforated holes must be field-installed in the chilled water inlet line as close as possible to the chiller. If located close enough to the chiller, the chilled water pump may be protected by the same strainer. The flow switch and strainer assure chilled water flow during unit operation. The loss or severe reduction of water flow could seriously impair the chiller performance or even result in tube freeze-up.

Condenser Water – The chiller is engineered for maximum efficiency at both design and part-load operation by taking advantage of the colder cooling tower water temperatures which naturally occur during the winter months. Appreciable power savings are realized from these reduced heads.

The minimum entering condenser water temperature for other full and part-load conditions is provided by the following equation:

$$^{\circ}\text{F Min ECWT} = \text{LCHWT} + 16 + [(\% \text{ load}/100) \times (10 - \text{full-load condenser water } \Delta T)]$$

$$^{\circ}\text{C Min ECWT} = \text{LCHWT} + 8.9 + [(\% \text{ load}/100) \times (5.6 - \text{full-load condenser water } \Delta T)]$$

Where: ECWT = entering condenser water temperature
LCHWT = leaving chilled water temperature

MULTIPLE UNITS

Selection – Many applications require multiple units to meet the total capacity requirements as well as to provide flexibility and some degree of protection against equipment shutdown. There are several common unit arrangements for this type of application. The MAXE chiller has been designed to be readily adapted to the requirements of these various arrangements.

Parallel Arrangement (Refer to Fig. 1) – Chillers may be applied in multiples with chilled and condenser water circuits connected in parallel between the units. Fig. 1 represents a parallel arrangement with two chillers. Parallel chiller arrangements may consist of equally or unequally sized units. When multiple units are in operation, they will load and unload at equal percentages of design full-load for the chiller.

Depending on the number of units and operating characteristics of the units, loading and unloading schemes should be designed to optimize the overall efficiency of the chiller plant. It is recommended to use an evaporator bypass piping arrangement to bypass fluid around evaporator of any unit which has cycled off at reduced load conditions. It is also recommended to alternate the chiller cycling order to equalize chiller starts and run hours.

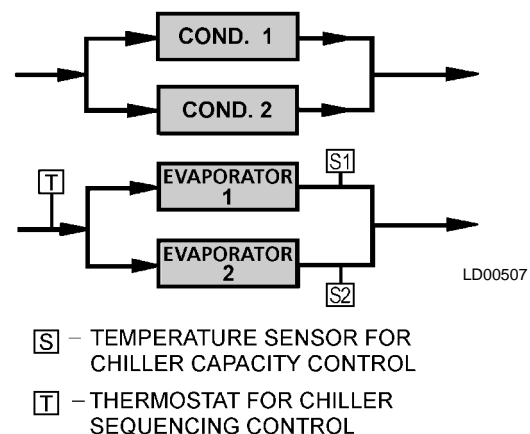

**FIG. 1 – PARALLEL EVAPORATORS
PARALLEL CONDENSERS**

Series Arrangement (Refer to Fig. 2) – The chillers may be applied in pairs with chilled water circuits con-

ected in series and condenser water circuits connected in parallel. All of the chilled water flows through both coolers with each unit handling approximately one-half of the total load. When the load decreases to a customer selected load value, one of the units will be shut down by a sequence control. Since all water is flowing through the operating unit, that unit will cool the water to the desired temperature.

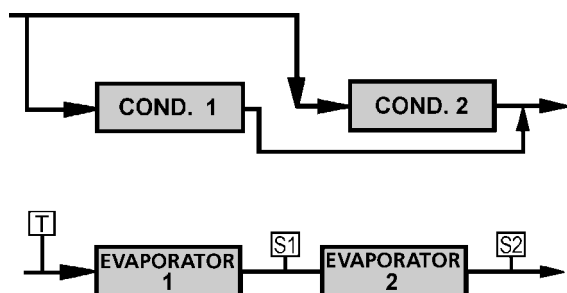

**FIG. 2 – SERIES EVAPORATORS
PARALLEL CONDENSERS**

LD00508

BRINE APPLICATIONS

The YR Screw Chiller, utilizing the Frick Refrigeration compressor, is a good match for the high head requirements of low temperature brine applications. This is particularly true of thermal ice storage systems, typically requiring 22°F (–5.6°C) to 24°F (–4.4°C) leaving brine temperatures. This performance is enhanced with the standard thermal storage control mode described on page 6.

Particular attention must be paid to the application of two or more chillers with evaporators in parallel or series when the brine temperature is below 32°F (0°C). The brine **MUST NOT** flow through the evaporator of the idle chiller, because it can cause the condenser water to freeze. A bypass or other type of arrangement is required that shuts off flow to the idle evaporator. When units are applied in series with lead/lag capability, the units should be identical.

REFRIGERANT RELIEF PIPING

Each chiller is equipped with pressure relief devices. The purpose of the relief devices is to quickly relieve excess pressure of the refrigerant charge to atmosphere, as a safety precaution in the event of an emergency such as a fire. They are set to relieve at an internal pressure of 235 psig (1620 kPa) and are located on the condenser, evaporator and oil separator; and are provided in accordance with ASHRAE 15 Safety Code and ASME or applicable pressure vessel code. Under these circumstances the relief devices may be relief valves,

overflow valves or type tested Safety Pressure switches or a combination of these devices.

Sized to the requirements of applicable codes, a vent line must run from the relief device to the outside of the building. This refrigerant relief piping must include a cleanable, vertical-leg dirt trap to catch vent-stack condensation. Vent piping must be arranged to avoid imposing a strain on the relief connections and should include one flexible connection.

SOUND AND VIBRATION CONSIDERATIONS

A MaxE chiller is not a source of objectionable sound and vibration in normal air conditioning applications. Neoprene isolation mounts are furnished as standard with each unit. Optional level-adjusting spring isolator assemblies designed for 1" static deflection are available.

MaxE chiller sound pressure level ratings will be furnished upon request.

Control of sound and vibration transmission must be taken into account in the equipment room construction as well as in the selection and installation of the equipment.

THERMAL INSULATION

No appreciable operating economy can be achieved by thermally insulating the chiller. However, the chiller's cold surfaces should be insulated with a vapor barrier insulation sufficient to prevent condensation. A chiller can be factory insulated with 3/4" (19mm) or 1-1/2" (38mm) thick insulation, as an option. This insulation will normally prevent condensation in environments with dry bulb temperatures of 50°F to 90°F (10°C to 32°C) and relative humidities up to 75% [3/4" (19mm) thickness] or 90% [1-1/2" (38mm) thickness]. The insulation is painted and the surface is flexible and reasonably resistant to wear. It is intended for a chiller installed indoors and, therefore, no protective covering of the insulation is usually required. If insulation is applied to the water boxes at the job site, it must be removable to permit access to the tubes for routine maintenance.

VENTILATION

The ASHRAE Standard 15 Safety Code for Mechanical Refrigeration requires that all machinery rooms be vented to the outdoors utilizing mechanical ventilation by one or more power-driven fans. This standard, plus National Fire Protection Association Standard 90A, state, local and other related codes should be reviewed for specific requirements.

Application Data (continued)

In addition, the ASHRAE Standard 15 requires a refrigerant vapor detector to be employed for all refrigerants. It is to be located in area where refrigerant from a leak would be likely to concentrate. An alarm is to be activated and the mechanical ventilation started at a value no greater than the TLV (Threshold Limit Value) of the refrigerant.

ELECTRICAL CONSIDERATIONS

Motor Voltage – Low voltage motors (200 - 600 volts) are furnished with six leads. Motor circuit conductor size must be in accordance with the National Electrical Code (NEC), or other applicable codes, for the motor full-load amperes (FLA). Flexible conduit should be used for the last several feet to the chiller in order to provide vibration isolation. Table 2 lists the allowable variation in voltage supplied to the chiller motor. The unit nameplate is stamped with the specific motor voltage and frequency for the appropriate motor.

TABLE 2 – MOTOR VOLTAGE VARIATIONS

FREQ.	RATED VOLTAGE	NAMEPLATE VOLTAGE	OPERATING VOLTAGE	
			MIN.	MAX.
60 HZ	200	200/208	180	220
	230	220/240	208	254
	380	380	342	415
	460	440/460/480	414	508
	575	575/600	520	635
50 HZ	380	380/400	342	423
	415	415	374	440

Starters – The chiller is available with a factory-mounted and wired YORK Solid State Starter for 200 - 600 volt applications. Other types of remote mounted starters are available. These electro-mechanical starters must be furnished in accordance with YORK Standard R-1131. Specification. This will ensure that starter components, controls, circuits, and terminal markings will be suitable for required overall system performance.

Controls – A 115 volt, single phase, 60 or 50 Hertz (4.5 kVa) power supply must be furnished to the chiller from a separate, fused disconnect or from a control transformer included as an option with electro-mechanical starters. No field control wiring is required, when the YORK SSS is supplied.

Copper Conductors – *Only copper conductors should be connected to compressor motors and starters.* Aluminum conductors have proven to be unsatisfactory when connected to copper lugs. Aluminum oxide and the difference in thermal conductivity between copper and aluminum cannot guarantee the required tight connection over a long period of time.

Power Factor Correction Capacitors – Capacitors can be applied to a chiller for the purpose of power factor correction. For remote-Mounted Electro-Mechanical Starters, the capacitors should be located on the load side of the starter. For YORK SSS, the capacitors must be located on the line side of the starter. The capacitors must be sized and installed to meet the National Electrical Code (NEC) and be verified by YORK.

Ampacity on Load Side of Starter – Electrical power wire size to the chiller is based on the minimum unit ampacity. For YORK SSS, this wiring is done at the factory. For remote starters, the National Electrical Code defines the calculation of ampacity, as summarized below. More specific information on actual amperage ratings will be supplied with the submittal drawings.

- Six-lead type of starting (Star-Delta)

Minimum circuit ampacity per conductor (1 of 6):
Ampacity = .721 x compressor motor amps.

- Three-lead type of starting (Across-the-Line, Autotransformer and Primary Reactor)

Minimum circuit ampacity per conductor (1 of 3):
Ampacity = 1.25 x compressor motor amps.

Ampacity on Line Side of Starter –

The only additional load on the circuit for the chiller would be the control transformer, unless it is supplied by a separate source.

$$\text{Min. Circuit Ampacity} = \frac{125\% \text{ of compr.}}{\text{motor amps}} + \text{FLA of all other loads on the circuit}$$

Branch Circuit Overcurrent Protection – The branch circuit overcurrent protection device(s) should be a time-delay type, with a minimum rating equal to the next standard fuse/breaker rating above the calculated value. It is calculated taking into account the compressor motor amps and may also include control transformer. Refer to submittal drawings for the specific calculations for each application.

MOTOR ELECTRICAL DATA

The full-load amperes (FLA) listed in Tables 3 and 4 are maximum values and correspond to the maximum motor kW listed. When the Input power (kW) is less than maximum motor kW, the FLA should be reduced using the following equation:

$$FLA = \frac{\text{Motor kW}}{\text{Max. Motor kW}} \times \text{Max. Motor FLA}$$

The benefit from the FLA correction is the possible use of smaller power wiring and/or starter size.

The locked rotor amperes (LRA) are read directly from Tables 3 and 4 for specific Motor Code and voltage. This is because the LRA is dependent only on motor size and voltage and is independent of input power (kW).

Inrush amperes (IRA) depend on LRA and the type of starter applied. The inrush can be calculated using a percentage of LRA shown in Table 5.

TABLE 3 – 60 HZ ELECTRICAL DATA

COMP.	NAME-PLATE VOLT.	AMP (MAX)		MOTOR DATA																		MAX. KW (hp)
				100%		90%		80%		70%		60%		50%		40%		30%		20%		
				PF	EFF	PF	EFF	PF	EFF	PF	EFF	PF	EFF	PF	EFF	PF	EFF	PF	EFF	PF	EFF	
T0/T1	200	850	3634	88.2	94.8	87.8	95.2	87.3	95.5	85.8	95.7	84.3	95.9	80.4	96.0	76.5	96.0	65.8	95.2	55.1	94.4	251.6 (321)
	208	825	3779	86.6	95.0	85.6	95.3	84.6	95.5	82.6	95.7	80.5	95.9	75.5	95.8	70.5	95.7	59.0	94.8	47.4	93.8	
	230	725	2901	89.2	94.5	89.1	95.0	89.0	95.4	88.2	95.7	87.3	96.0	84.5	96.1	81.6	96.2	72.4	95.6	63.1	94.9	
	240	695	3027	88.2	94.9	87.7	95.2	87.2	95.5	85.8	95.8	84.3	96.0	80.4	96.0	76.5	96.0	65.8	95.2	55.0	94.4	
	380	438	1727	89.3	94.6	89.3	95.0	89.2	95.4	88.5	95.7	87.8	96.0	85.1	96.1	82.4	96.2	73.5	95.6	64.6	95.0	
	440	370	1390	89.6	94.2	89.8	94.7	90.0	95.2	89.6	95.6	89.2	95.9	87.2	96.1	85.2	96.3	77.7	95.9	70.1	95.4	
	460	354	1453	89.2	94.6	89.1	95.0	88.9	95.4	88.1	95.7	87.3	96.0	84.5	96.1	81.6	96.2	72.4	95.6	63.1	94.9	
	480	339	1516	88.2	94.9	87.7	95.2	87.2	95.5	85.8	95.8	84.3	96.0	80.4	96.0	76.5	96.0	65.8	95.2	55.0	94.4	
	575	300	1162	89.2	94.6	89.1	95.0	88.9	95.4	88.1	95.7	87.3	96.0	84.4	96.1	81.5	96.2	72.3	95.6	93.1	95.0	
	600	288	1213	88.2	94.9	87.7	95.3	87.2	95.6	85.8	95.8	84.3	96.0	80.4	96.0	76.5	96.0	65.8	95.3	55.0	94.5	
T2/T3	200	882	4048	90.4	94.8	90.2	95.2	90.0	95.5	89.2	95.8	88.3	96.0	85.6	96.0	82.9	96.0	73.8	95.3	64.7	94.6	275.9 (351)
	208	860	4210	89.1	95.0	88.5	95.3	87.8	95.6	86.4	95.8	94.9	96.0	81.3	96.0	77.6	95.9	67.1	95.0	56.5	94.1	
	230	760	3520	90.5	94.7	90.4	95.1	90.2	95.4	89.5	95.7	88.7	95.9	86.2	96.0	83.7	96.0	75.0	95.4	66.3	94.7	
	240	737	3673	89.3	95.0	88.8	95.3	88.3	95.5	86.9	95.7	85.4	95.9	81.9	95.9	78.3	95.9	67.9	95.0	57.5	94.1	
	380	464	2130	90.3	94.8	90.1	95.2	89.9	95.5	89.1	95.8	88.2	96.0	85.6	96.0	82.9	96.0	73.8	95.3	64.7	94.6	
	440	400	1603	91.0	94.4	91.2	94.9	91.4	95.3	91.1	95.6	90.8	95.9	89.3	96.1	87.7	96.2	80.9	95.7	74.0	95.1	
	460	383	1676	90.5	94.7	90.4	95.1	90.2	95.5	89.5	95.8	88.7	96.0	86.2	96.1	83.7	96.1	75.0	95.4	66.2	94.7	
	480	372	1749	89.3	95.0	88.8	95.3	88.2	95.6	86.8	95.8	85.4	96.0	81.8	96.0	78.2	95.9	67.9	95.0	57.5	94.1	
	575	305	1408	90.7	94.7	90.7	95.1	90.6	95.5	90.0	95.8	89.4	96.0	87.2	96.1	85.0	96.2	77.0	95.5	68.9	94.8	
	600	293	1469	89.9	95.0	89.5	95.3	89.1	95.6	88.0	95.8	86.9	96.0	83.8	96.0	80.7	96.0	71.0	95.2	61.2	94.4	

NOTE: FLA = Full-load Amps; LRA = Locked Rotor Amps; PF = Power Factor; EFF = Motor Efficiency
100% Loading is Percentage of Maximum Motor Load; not of Specific Application

TABLE 4 – 50 HZ ELECTRICAL DATA

COMP.	NAME- PLATE VOLT.	AMP (MAX)		MOTOR DATA																		MAX. KW (hp)
				100%		90%		80%		70%		60%		50%		40%		30%		20%		
				FLA	LRA	PF	EFF	PF	EFF	PF	EFF	PF	EFF	PF	EFF	PF	EFF	PF	EFF	PF	EFF	
T0/T1	380	364	1414	89.3	93.7	89.2	94.3	89.1	94.8	88.4	95.2	87.7	95.6	84.9	95.8	82.1	95.9	73.3	95.3	64.5	94.7	210.2 (267)
	400	348	1488	88.2	94.1	87.7	94.6	87.2	95.0	85.9	95.3	84.5	95.6	80.4	95.7	76.3	95.7	65.6	94.9	54.9	94.1	
	415	333	1544	89.2	93.8	89.1	94.4	88.9	94.9	88.1	95.3	87.3	95.6	84.3	95.8	81.3	95.9	72.2	95.3	93.1	94.6	
T2/T3	380	390	1639	90.4	94.0	90.3	94.5	90.1	94.9	89.4	95.3	88.6	95.6	86.2	95.8	83.7	96.0	75.2	95.4	66.6	94.8	231.9 (292)
	400	371	1725	89.6	94.4	89.1	94.8	88.6	95.2	87.3	95.5	85.9	95.7	82.4	95.8	78.9	95.8	68.5	95.1	58.1	94.3	
	415	354	1790	90.4	94.0	90.3	94.5	90.1	94.9	89.3	95.3	88.5	95.6	86.1	95.8	83.6	95.9	75.1	95.4	66.5	94.8	

NOTE: FLA = Full-load Amps; LRA = Locked Rotor Amps; PF = Power Factor; EFF = Motor Efficiency
100% Loading is Percentage of Maximum Motor Load; not of Specific Application

TABLE 5 – MOTOR STARTERS

TYPE STARTER	SOLID STATE STARTER	STAR DELTA		AUTO TRANSFORMER			ACROSS THE LINE
60HZ 50 HZ	200-600 380-415	200-600 380-415	200-600 380-415	200-600 380-415	200-600 380-415	200-600 380-415	200-600 380-415
TRANSITION % TAP INRUSH AS A % OF LRA	NONE — 45	CLOSED — 33	OPEN — 33	CLOSED 57.7 33	CLOSED 65 42.3	CLOSED 80 64	— — 100

TABLE 6 – AVAILABLE COMPRESSOR/SHELL COMBINATIONS

COMPRESSOR CODE	EVAPORATOR SHELL	CONDENSER SHELL
T0, T1	TB, TC, TD	TB, TC, TD
	VB, VC, VD	VB, VC, VD
T1	WB, WC, WD	WB, WC, WD
T2/T3	WB, WC, WD	WB, WC, WD
	XB, XC, XD	XB, XC, XD

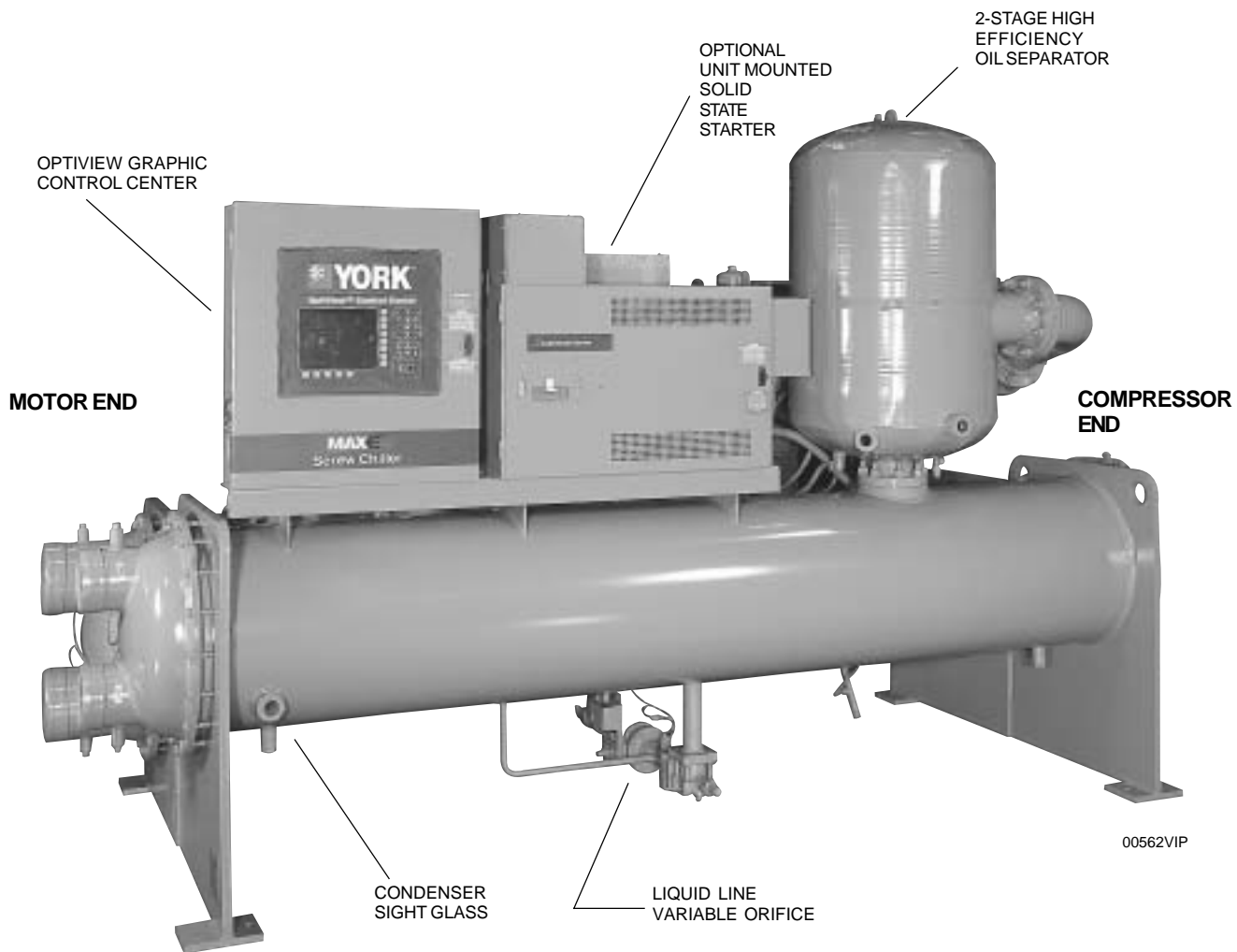

Dimensions

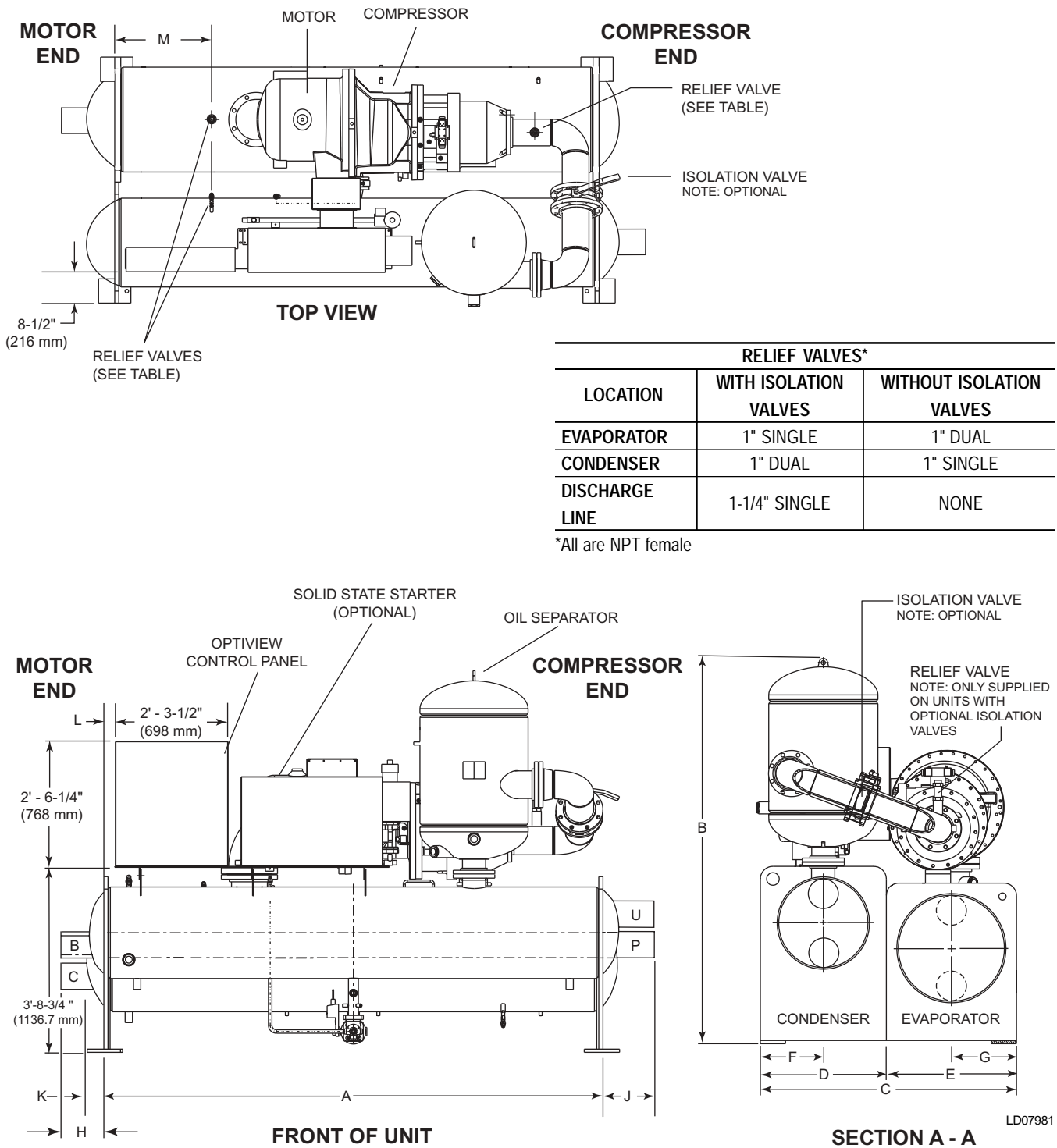

FIG. 3 – T0 & T3 COMPRESSORS – EVAPORATOR, CONDENSER AND WATER BOXES DIMENSIONS

DIM.	EVAPORATOR - CONDENSER SHELL CODES									
	T0 & T1 COMPRESSORS				T1 COMPRESSORS		T2 & T3 COMPRESSORS			
	T - T	V - V	T - T	V - V	W - W	W - W	W - W	X - X	W - W	X - X
A	10'-0"	14'-0"	3048 mm	4267 mm	12'-0"	3657 mm	12'-0"	16'-0"	3658 mm	4877 mm
B	7'-5-1/8"	7'-5-1/8"	2264 mm	2264 mm	7'-9-3/4"	2381 mm	8'-10-7/8"	8'-10-7/8"	2715 mm	2715 mm
C	5'-1"	5'-1"	1550 mm	1550 mm	5'-6"	1676 mm	5'-6"	5'-6"	1676 mm	1676 mm
D	2'-6"	2'-6"	762 mm	762 mm	2'-7"	787 mm	2'-7"	2'-7"	787 mm	787 mm
E	2'-7"	2'-7"	787 mm	787 mm	2'-11"	889 mm	2'-11"	2'-11"	889 mm	889 mm
F	1'-3"	1'-3"	381 mm	381 mm	1'-3-1/2"	114 mm	1'-3-1/2"	1'-3-1/2"	394 mm	394 mm
G	1'-3-1/2"	1'-3-1/2"	394 mm	394 mm	1'-5-1/2"	165 mm	1'-5-1/2"	1'-5-1/2"	445 mm	445 mm
L	2-3/4"	2'- 2-3/4"	70 mm	679 mm	2-3/4"	70 mm	2-3/4"	2'-2-3/4"	70 mm	679 mm
M	1'-3"	3'-3"	381 mm	991 mm	1'-3"	381 mm	1'-3"	3'-3"	381 mm	991 mm

DIM.	WATER BOX DIMENSIONS (FT. - IN)					
	EVAPORATORS T & V			CONDENSER T & V		
	1 PASS	2 PASS	3 PASS	1 PASS	2 PASS	3 PASS
H	1'-2-3/4"	1'-1-1/2"	1'-1-1/2"	—	—	—
J	—	—	—	1'-2-3/4"	1'-0-1/2"	1'-0-1/2"
DIM.	REAR HEAD 2 PASS			REAR HEAD 2 PASS		
K	8-3/4"			7-5/8"		

DIM.	WATER BOX DIMENSIONS (mm)					
	EVAPORATORS T & V			CONDENSER T & V		
	1 PASS	2 PASS	3 PASS	1 PASS	2 PASS	3 PASS
H	375	343	343	—	—	—
J	—	—	—	375	318	318
DIM.	REAR HEAD 2 PASS			REAR HEAD 2 PASS		
K	222			194		

DIM.	WATER BOX DIMENSIONS (FT. - IN)					
	EVAPORATORS W & X			CONDENSER W & X		
	1 PASS	2 PASS	3 PASS	1 PASS	2 PASS	3 PASS
H	1'-2-1/4"	1'-2-1/4"	1'-2-1/4"	—	—	—
J	—	—	—	1'-2-1/4"	1'-2-1/4"	1'-2-1/4"
DIM.	REAR HEAD 2 PASS			REAR HEAD 2 PASS		
K	5-5/8"			5-5/8"		

DIM.	WATER BOX DIMENSIONS (mm)					
	EVAPORATORS W & X			CONDENSER W & X		
	1 PASS	2 PASS	3 PASS	1 PASS	2 PASS	3 PASS
H	362	362	362	—	—	—
J	—	—	—	362	362	362
DIM.	REAR HEAD 2 PASS			REAR HEAD 2 PASS		
K	143			143		

Dimensions (Ft.-In.) – Nozzle Arrangements

EVAPORATORS – COMPACT WATER BOXES

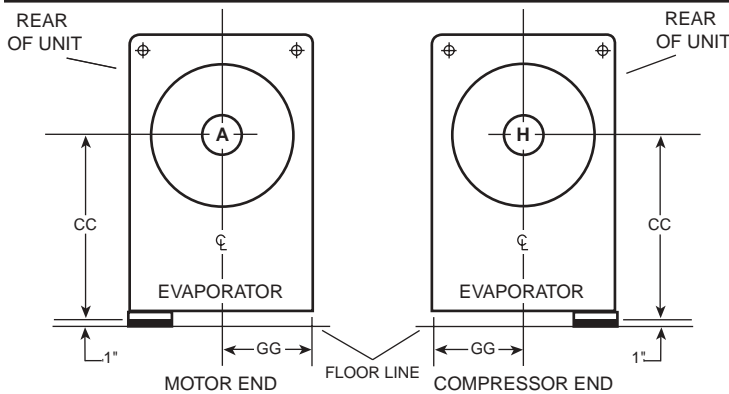

1-PASS

NOZZLE ARRANGEMENTS		
NO. OF PASSES	EVAP.	
	IN	OUT
1	A H	H A

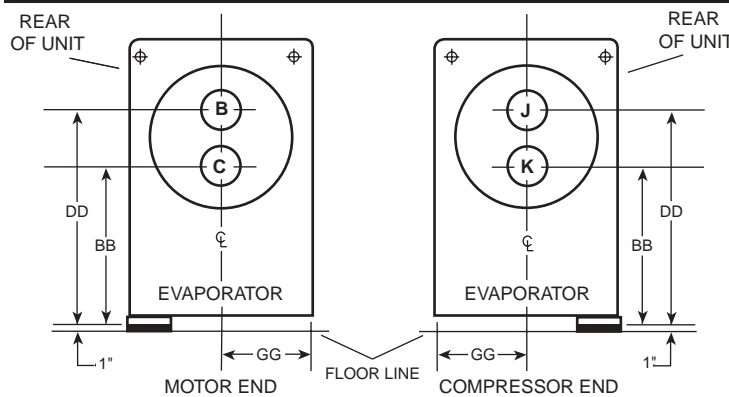

2-PASS

NOZZLE ARRANGEMENTS		
NO. OF PASSES	EVAP.	
	IN	OUT
2	C K	B J

NOTE: Water must enter through bottom connection to achieve rated performance.

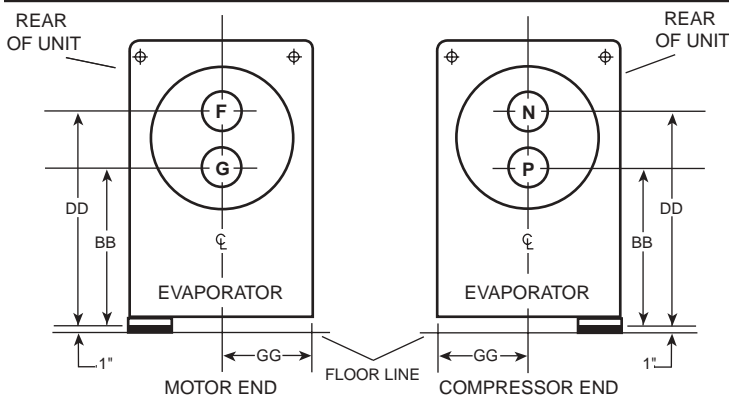

3-PASS

NOZZLE ARRANGEMENTS		
NO. OF PASSES	EVAP.	
	IN	OUT
3	G P	N F

NOTE: Water must enter through bottom connection to achieve rated performance.

LD07615

EVAPORATOR SHELL CODE	NOZZLE PIPE SIZE			EVAPORATOR NOZZLE DIMENSIONS							
	NO. OF PASSES			1-PASS		2-PASS		3-PASS			
	1	2	3	CC ²	G G	BB ²	DD ²	G G	BB ²	D D	G G
T, V	8"	6"	4"	1'-10-3/4"	1'-3-1/2"	1'-3"	2'-6-1/2"	1'-3-1/2"	1'-3"	2'-6-1/2"	1'-3-1/2"
W, X	10"	8"	6"	2'-0-3/4"	1'-5-1/2"	1'-4-3/4"	2'-8-3/4"	1'-5-1/2"	1'-4-3/4"	2'-8-3/4"	1'-5-1/2"

NOTES:

- Standard water nozzles are furnished as welding stub-outs with Victaulic grooves, allowing the option of welding, flanges, or use of Victaulic couplings. Factory installed, class 150 (ANSI B16.5, round slip-on, forged carbon steel with 1/16" raised face), water flanged nozzles are optional (add 1/2" to nozzle length). Companion flanges, nuts, bolts, and gaskets are not furnished.
- Add 1" for isolators as shown.
- One-, two- and three-pass nozzle arrangements are available only in pairs shown and for all shell codes. Any pair of evaporator nozzles may be used in combination with any pair of condenser nozzles.
- Connected piping should allow for removal of compact water boxes for tube access and cleaning.
- Rear of unit is defined as side of chiller opposite control center.

Dimensions (mm) – Nozzle Arrangements

EVAPORATORS – COMPACT WATER BOXES

1-PASS

NOZZLE ARRANGEMENTS		
NO. OF PASSES	EVAP.	
	IN	OUT
1	A H	H A

2-PASS

NOZZLE ARRANGEMENTS		
NO. OF PASSES	EVAP.	
	IN	OUT
2	C K	B J

NOTE: Water must enter through bottom connection to achieve rated performance.

3-PASS

NOZZLE ARRANGEMENTS		
NO. OF PASSES	EVAP.	
	IN	OUT
3	G P	N F

NOTE: Water must enter through bottom connection to achieve rated performance.

LD07615

EVAPORATOR SHELL CODE	NOZZLE PIPE SIZE			EVAPORATOR NOZZLE DIMENSIONS							
	NO. OF PASSES			1-PASS		2-PASS			3-PASS		
	1	2	3	CC ²	GG	BB ²	DD ²	GG	BB ²	DD	GG
T, V	8"	6"	4"	578	343	330	775	343	330	775	394
W, X	10"	8"	6"	629	445	425	832	445	425	832	445

NOTES:

1. Standard water nozzles are furnished as welding stub-outs with Victaulic grooves, allowing the option of welding, flanges, or use of Victaulic couplings. Factory installed, class 150 (ANSI B16.5, round slip-on, forged carbon steel with 1/16" raised face), water flanged nozzles are optional (add 1/2" to nozzle length). Companion flanges, nuts, bolts, and gaskets are not furnished.
2. Add 1" for isolators as shown.
3. One-, two- and three-pass nozzle arrangements are available only in pairs shown and for all shell codes. Any pair of evaporator nozzles may be used in combination with any pair of condenser nozzles.
4. Connected piping should allow for removal of compact water boxes for tube access and cleaning.
5. Rear of unit is defined as side of chiller opposite control center.

Dimensions (Ft.-In.) – Nozzle Arrangements

CONDENSERS – COMPACT WATER BOXES

1-PASS

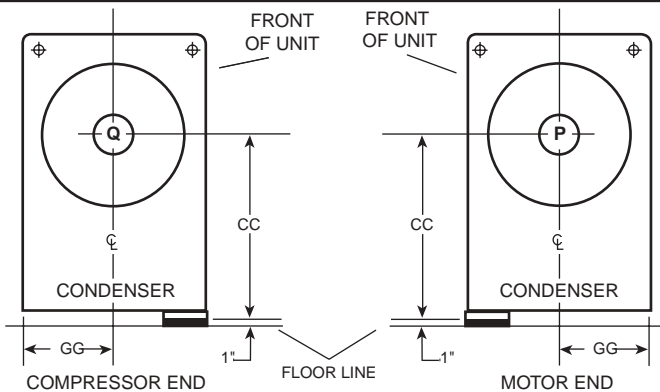

NOZZLE ARRANGEMENTS		
NO. OF PASSES	COND.	
	IN	OUT
1	P Q	Q P

2-PASS

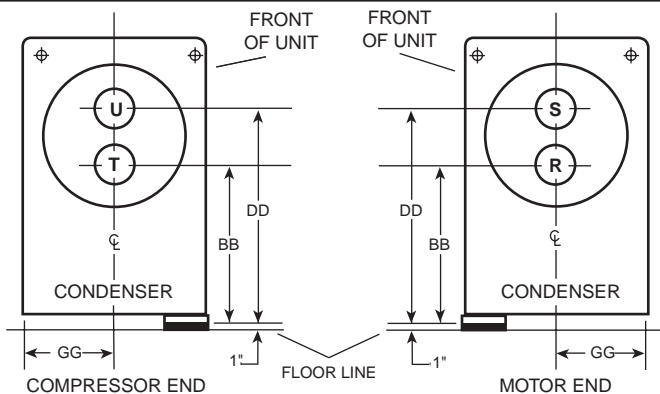

NOZZLE ARRANGEMENTS		
NO. OF PASSES	COND.	
	IN	OUT
2	R T	S U

NOTE: Water must enter through bottom connection to achieve rated performance

3-PASS

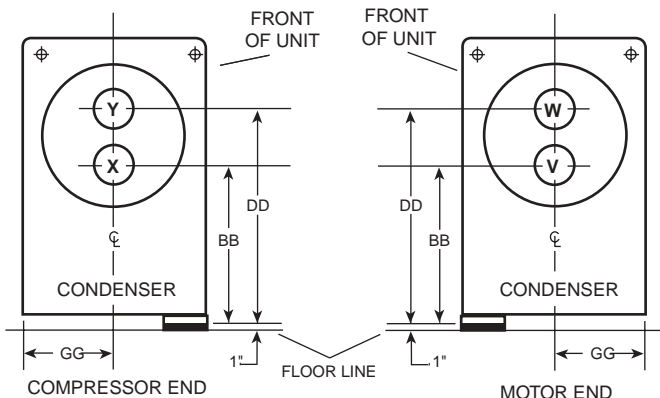

NOZZLE ARRANGEMENTS		
NO. OF PASSES	COND.	
	IN	OUT
3	V X	Y W

NOTE: Water must enter through bottom connection to achieve rated performance

LD07982

CONDENSER SHELL CODE	NOZZLE PIPE SIZE			CONDENSER NOZZLE DIMENSIONS							
	NO. OF PASSES			1-PASS		2-PASS			3-PASS		
	1	2	3	CC ²	GG	BB ²	DD ²	GG	BB ²	DD ²	GG
T, V	10"	6"	6"	2'-4-3/4"	1'-3"	1'-9-3/4"	2'-11-3/4"	1'-3"	1'-9-3/4"	2'-11-3/4"	1'-3"
W, X	12"	8"	6"	2'-6-3/4"	1'-3-1/2"	1'-11"	3'-2-1/2"	1'-3-1/2"	1'-11"	3'-2-1/2"	1'-3-1/2"

NOTES:

- Standard water nozzles are furnished as welding stub-outs with Victaulic grooves, allowing the option of welding, flanges, or use of Victaulic couplings. Factory installed, class 150 (ANSI B16.5, round slip-on, forged carbon steel with 1/16" raised face), water flanged nozzles are optional (add 1/2" to nozzle length). Companion flanges, nuts, bolts, and gaskets are not furnished.
- Add 1" for isolators as shown.
- One-, two- and three-pass nozzle arrangements are available only in pairs shown and for all shell codes. Any pair of condenser nozzles may be used in combination with any pair of evaporator nozzles.
- Connected piping should allow for removal of compact water boxes for tube access and cleaning.
- Front of unit is defined as side of chiller where control center is mounted.

Dimensions (mm) – Nozzle Arrangements

CONDENSERS – COMPACT WATER BOXES

1-PASS

NOZZLE ARRANGEMENTS		
NO. OF PASSES	COND.	
	IN	OUT
1	P Q	Q P

2-PASS

NOZZLE ARRANGEMENTS		
NO. OF PASSES	COND.	
	IN	OUT
2	R T	S U

NOTE: Water must enter through bottom connection to achieve rated performance

3-PASS

NOZZLE ARRANGEMENTS		
NO. OF PASSES	COND.	
	IN	OUT
3	V X	Y W

NOTE: Water must enter through bottom connection to achieve rated performance

LD07983

CONDENSER SHELL CODE	NOZZLE PIPE SIZE			CONDENSER NOZZLE DIMENSIONS							
	NO. OF PASSES			1-PASS		2-PASS			3-PASS		
	1	2	3	CC ²	G G	BB ²	DD ²	G G	BB ²	DD ²	G G
T, V	10"	6"	6"	730	381	553	908	381	553	908	381
W, X	12"	8"	6"	781	394	584	978	394	584	978	394

NOTES:

- Standard water nozzles are furnished as welding stub-outs with Victaulic grooves, allowing the option of welding, flanges, or use of Victaulic couplings. Factory installed, class 150 (ANSI B16.5, round slip-on, forged carbon steel with 1.59 mm raised face), water flanged nozzles are optional (add 12.7 mm to nozzle length). Companion flanges, nuts, bolts, and gaskets are not furnished.
- Add 25.4 mm for isolators as shown.
- One-, two- and three-pass nozzle arrangements are available only in pairs shown and for all shell codes. Any pair of condenser nozzles may be used in combination with any pair of evaporator nozzles.
- Connected piping should allow for removal of compact water boxes for tube access and cleaning.
- Front of unit is defined as side of chiller where control center is mounted.

Dimensions (mm) – Floor Layout

NEOPRENE ISOLATORS

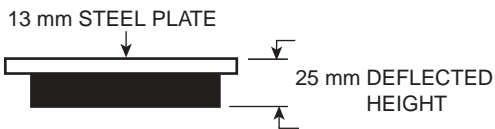
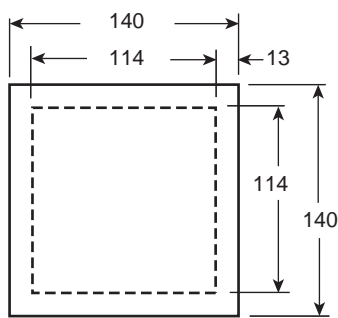
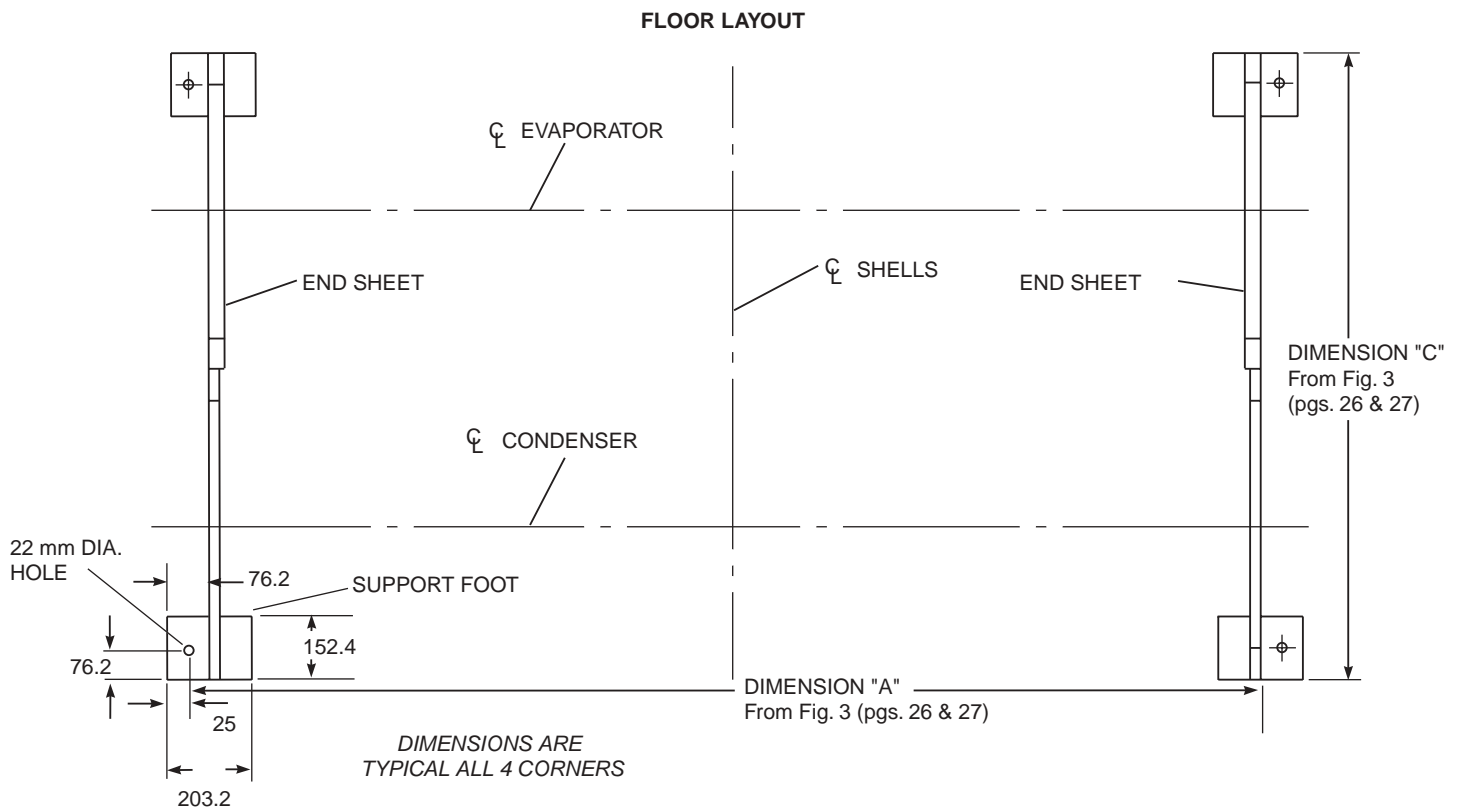

UNIT WEIGHT UP TO 7,423 KGS.

ISOLATOR TO BE CENTERED UNDER SUPPORT FOOT

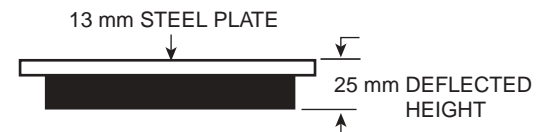
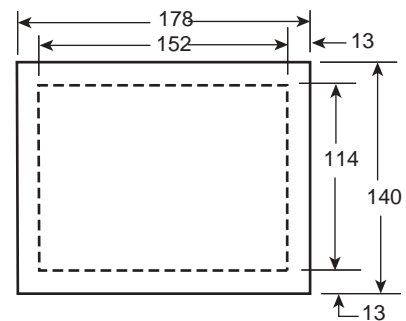

UNIT WEIGHT 7,423 TO 13,107 KGS.

Dimensions – Floor Layout

SPRING ISOLATORS

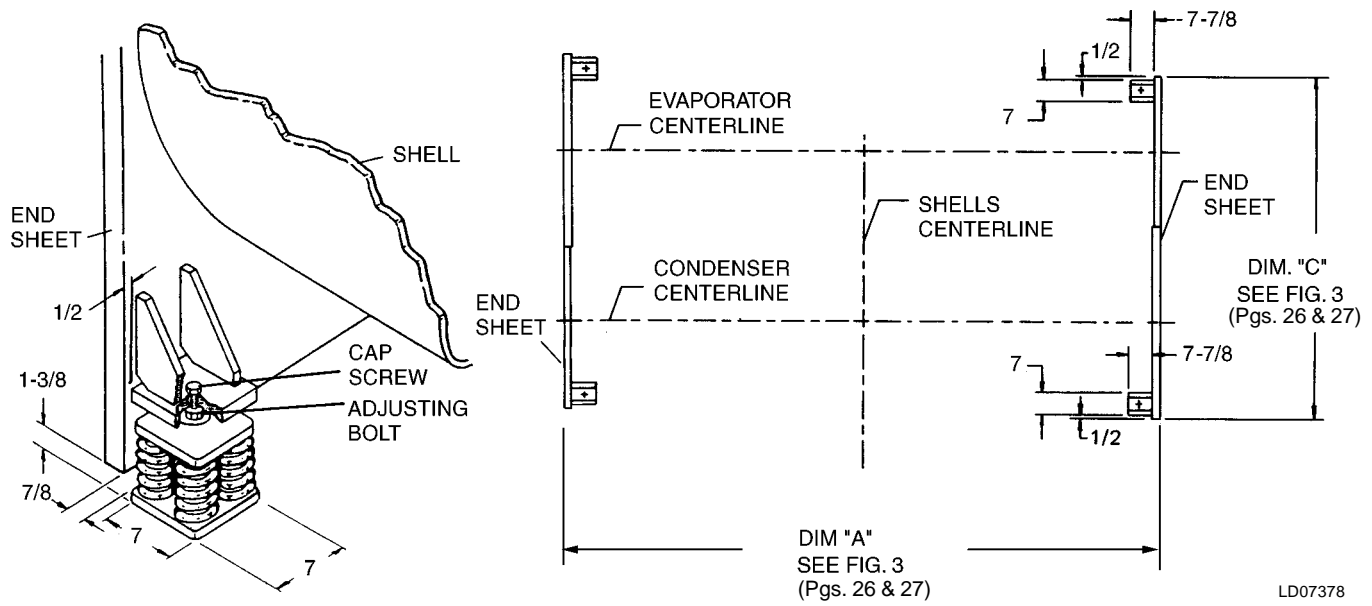

LD07378

ALL DIMENSIONS ARE IN INCHES

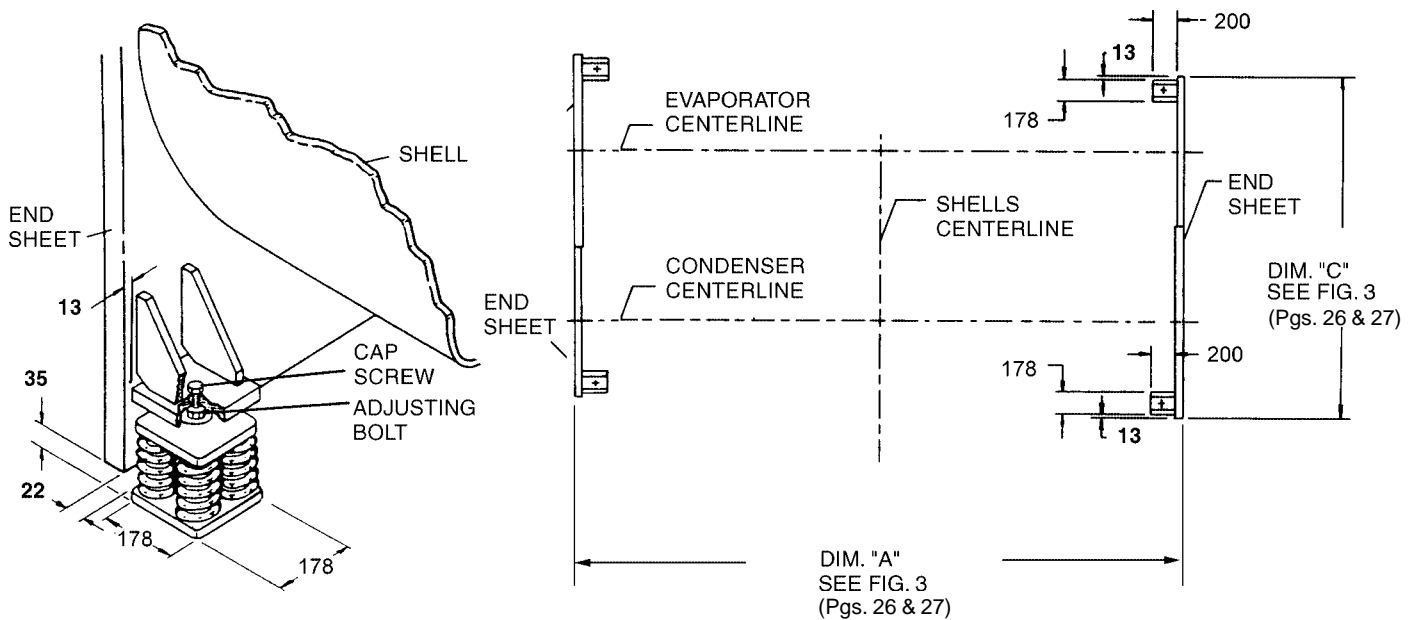

LD07379

ALL DIMENSIONS ARE IN MILLIMETERS

Weights

UNIT WEIGHTS

COMP.	SHELLS	SHIPPING WEIGHT		OPERATING WEIGHT		REFRIGERANT CHARGE		LOADING PER ISOLATOR	
		(LBS)	(KG)	(LBS)	(KG)	(LBS)	(KG)	(LBS)	(KG)
T0/T1	TBTB	11,860	5,380	13,110	5,948	650	295	3,278	1,485
	TBTC	11,910	5,400	13,200	5,988	650	295	3,303	1,495
	TBTD	12,010	5,450	13,350	6,053	650	295	3,338	1,515
	TCTB	11,960	5,425	13,250	6,013	650	295	3,313	1,500
	TCTC	12,010	5,450	13,340	6,053	650	295	3,338	1,515
	TCTD	12,110	5,495	13,490	6,123	650	295	3,373	1,530
	TDTB	12,070	5,475	13,410	6,083	650	295	3,353	1,520
	TDTC	12,120	5,500	13,500	6,123	650	295	3,378	1,530
	TDTD	12,220	5,540	13,650	6,193	650	295	3,413	1,545
	VBVB	12,680	5,750	14,320	6,495	900	408	3,580	1,625
	VBVC	12,750	5,785	14,450	6,555	900	408	3,615	1,640
	VBVD	12,890	5,845	14,660	6,649	900	408	3,665	1,665
	VCVB	12,820	5,815	14,520	6,586	900	408	3,630	1,645
	VCVC	12,900	5,850	14,650	6,645	900	408	3,665	1,665
	VCVD	13,030	5,910	14,850	6,735	900	408	3,715	1,685
	VDVB	12,990	5,890	14,750	6,690	900	408	3,690	1,675
VDVC	13,070	5,930	14,890	6,755	900	408	3,725	1,690	
VDVD	13,200	5,990	15,090	6,845	900	408	3,775	1,710	
T1	WBWB	14,660	6,650	17,160	7,784	1,250	567	4,290	1,946
	WBWC	14,930	6,772	17,550	7,961	1,250	567	4,388	1,990
	WBWD	15,520	7,040	18,020	8,174	1,250	567	4,505	2,043
	WCWB	14,840	6,731	17,410	7,897	1,250	567	4,353	1,975
	WCWC	15,110	6,854	17,800	8,074	1,250	567	4,450	2,019
	WCWD	15,440	7,004	18,280	8,292	1,250	567	4,570	2,073
	WDWB	15,070	6,836	17,730	8,042	1,250	567	4,433	2,011
	WDWC	15,340	6,958	18,120	8,219	1,250	567	4,530	2,055
	WDWD	15,670	7,108	18,600	8,437	1,250	567	4,650	2,109
T2/T3	WBWB	17,810	8,079	20,310	9,213	1,250	567	5,078	2,303
	WBWC	18,070	8,197	20,690	9,384	1,250	567	5,172	2,346
	WBWD	18,400	8,346	21,170	9,603	1,250	567	5,293	2,400
	WCWB	17,990	8,160	20,560	9,326	1,250	567	5,140	2,331
	WCWC	18,260	8,283	20,950	9,503	1,250	567	5,238	2,375
	WCWD	18,580	8,428	21,420	9,716	1,250	567	5,355	2,429
	WDWB	18,220	8,265	20,880	9,471	1,250	567	5,220	2,367
	WDWC	18,490	8,387	21,270	9,648	1,250	567	5,318	2,412
	WDWD	18,810	8,532	21,740	9,861	1,250	567	5,435	2,465
	XBXB	19,110	8,669	22,200	10,070	1,550	703	5,550	2,518
	XBXC	19,370	8,786	22,620	10,260	1,550	703	5,655	2,565
	XBXD	19,700	8,935	23,150	10,500	1,550	703	5,788	2,625
	XCXB	19,360	8,782	22,540	10,224	1,550	703	5,635	2,556
	XCXC	19,620	8,900	22,960	10,415	1,550	703	5,740	2,603
	XCXD	19,950	9,049	23,490	10,655	1,550	703	5,873	2,664
	XDXB	19,670	8,922	22,970	10,419	1,550	703	5,743	2,605
XDXC	19,940	9,045	23,400	10,614	1,550	703	5,850	2,654	
XDXD	20,260	9,190	23,920	18,850	1,550	703	5,980	2,713	

SOLID STATE STARTER WEIGHT

SIZE	LBS	KGS
7L, 14L	200	91
26L, 33L	300	136

Guide Specifications

GENERAL

Furnish and install where indicated on the drawings YORK MaxE Rotary Screw Liquid Chilling Unit(s). Each unit shall produce a capacity of _____ tons, cooling GPM of _____ from _____ °F to _____ °F when supplied with _____ GPM of condenser water at _____ °F. Power input shall not exceed _____ kW with an IPLV (NPLV) of _____. The evaporator shall be selected for _____ ft² °F hr/BTU fouling factor and a maximum liquid pressure drop of _____ ft. Water side shall be designed for 150 or 300 psig working pressure. The condenser shall be selected for _____ fouling factor and maximum liquid pressure drop of _____ ft. Water side shall be designed for 150 or 300 psig working pressure. Power shall be supplied to the compressor motor at _____ volts – 3-phase – (60)(50) Hertz and controls at 115 volts – 1-phase – (60)(50) Hertz.

– (or) –

Furnish and install where indicated on the drawings YORK MaxE Rotary Screw Liquid Chilling Unit(s). Each unit shall produce a capacity of _____ kW, cooling _____ L/S of _____ from _____ °C to _____ °C when supplied with _____ L/S of condenser water at _____ °C. Power input shall not exceed _____ kW with an IPLV (NPLV) of _____. The evaporator shall be selected for _____ M² °C/W fouling factor and a maximum liquid pressure drop of _____ kPa. Water side shall be designed for 1034 or 2068 kPa working pressure. The condenser shall be selected for _____ M² °C/W fouling factor and maximum liquid pressure drop of _____ kPa. Water side shall be designed for 1034 or 2068 kPa working pressure. Power shall be supplied to the compressor motor at _____ volts – 3-phase – 50 Hz and controls at 115 volts – 1-phase – 50 Hz.

Performance shall be certified or rated in accordance with the latest edition of ARI Standard 550/590-98 as applicable. Only chillers that are listed in the ARI Certification Program for Water Chilling Packages using the vapor compression cycle are acceptable.

Each unit shall be completely factory packaged including evaporator, condenser, subcooler, oil separator, compressor/motor, lubrication system, OptiView Control Center, Solid State Starter (optional), refrigerant isolation valves (optional) and all interconnecting piping and wiring. The factory package shall consist of a “Leaktight”

design, with no pipe thread connections that can loosen and leak over time. All units shall ship with a full charge of refrigerant HFC-134a and oil. Alternatively, the chiller shall be shipped with the compressor, control panel and oil separator removed (Form 3) or also with the shells separated (Form 7) to allow rigging into the equipment room. All units that ship disassembled shall be assembled and factory run tested prior to disassembly and shipment).

Compressor

The compressor shall be a rotary-screw type. The compressor housing shall be of cast iron, precision machined to provide minimal clearance for the rotors. The rotors shall be manufactured from forged steel and use asymmetric profiles operating at a maximum speed of (3570 RPM/60 Hz) (2975 RPM/50 Hz). The compressor shall incorporate a complete anti-friction bearing design to reduce power and increase reliability; four separate cylindrical roller bearings to handle radial loads; and two 4-point angular contact ball bearings to handle axial loads. A check valve shall be incorporated in the compressor housing to prevent rotor backspin during shutdown.

Capacity control shall be achieved by use of a slide valve to provide fully modulating control from 100% to 20% of full-load. The slide valve shall be actuated by system differential pressure, controlled by external solenoid valves through the OptiView Control Center. The unit shall be capable of operating with lower temperature cooling tower water during part-load operation in accordance with ARI Standard 550/590.

Lubrication System

An adequate supply of oil shall be available to the compressor at all times. During start-up and coastdown, this shall be achieved by oil reservoirs in the compressor. During operation, oil shall be delivered by positive system pressure differential.

All chillers shall be provided with a single oil filter housing with isolation valves. An optional dual filter is available which allows immediate switching from one filter to the other, eliminating downtime during filter changes. The off-line oil filter must be capable of being changed during chiller operation. The chiller shall ship with a 3 micron absolute oil filter, (two filters for dual filter option) maintaining a clean oil system and ensuring superior compressor life.

A 500W immersion oil heater shall be provided and temperature actuated to effectively remove refrigerant from the oil. Power wiring to the Control Center shall be factory installed. An oil eductor shall be provided to automatically remove oil which may have migrated to the evaporator and return it to the compressor. The oil separator shall be of a vertical design with no moving parts, and shall provide high-efficiency oil separation before the refrigerant enters the heat exchangers. The oil separator shall be designed, tested and stamped in accordance with ASME Boiler and Pressure Vessel Code, Section VIII – Division 1.

Motor

The motor shall be 2-pole, continuous duty, cage induction type, and shall utilize suction gas cooling (semi-hermetic design). Motor full-load amperes at design conditions shall not exceed motor nameplate (FLA). Motor shall be designed for use with the type starter specified.

For units utilizing remote electromechanical starters, a large steel terminal box with gasketed front access cover shall be provided for field connected conduit. Overload/overcurrent transformers shall be furnished with all units. (For units furnished with factory packaged Solid State Starters, refer to the “Options” section.)

Evaporator

Evaporator shall be of the shell-and-tube, flooded type designed for 235 psig (1620 kPa) working pressure on the refrigerant side. Shell shall be fabricated from rolled carbon steel plate with fusion welded seams or carbon steel pipe; have carbon steel tube sheets, drilled and reamed to accommodate the tubes; and intermediate tube supports spaced no more than four feet apart. The refrigerant side shall be designed, tested and stamped in accordance with ASME Boiler and Pressure Vessel Code, Section VIII – Division 1. Tubes shall be high-efficiency, internally enhanced type. Each tube shall be roller expanded into the tube sheets providing a leak-proof seal, and be individually replaceable. Water velocity through the tubes shall not exceed 12 FPS (3.6 m/s). Liquid level sight glass shall be located on the side of the shell to aid in determining proper refrigerant charge. The evaporator shall have a refrigerant relief device to meet the requirements of ASHRAE 15 Safety Code for Mechanical Refrigeration.

Water boxes shall be removable to permit tube cleaning and replacement. Stubout water connections having Victaulic grooves shall be provided. Water boxes shall be designed for 150 psig (1034 kPa) design working pressure. Vent and drain connections with plugs shall be provided on each water box.

Condenser

Condenser shall be of the shell-and-tube type, designed for 235 psig (1620 kPa) working pressure on the refrigerant side. Shell shall be fabricated from rolled carbon steel plate with fusion welded seams or carbon steel pipe; have carbon steel tube sheets, drilled and reamed to accommodate the tubes; and intermediate tube supports spaced no more than four feet apart. A refrigerant subcooler shall be provided for improved cycle efficiency. The refrigerant side shall be designed, tested and stamped in accordance with ASME Boiler and Pressure Vessel Code, Section VIII – Division 1. Tubes shall be high-efficiency, internally enhanced type. Each tube shall be roller expanded into the tube sheets providing a leak-proof seal, and be individually replaceable. Water velocity through the tubes shall not exceed 12 FPS. The condenser shall have refrigerant relief device to meet the requirements of ASHRAE 15 Safety Code for Mechanical Refrigeration.

Water boxes shall be removable to permit tube cleaning and replacement. Stubout water connections having Victaulic grooves shall be provided. Water Boxes shall be designed for 150 psig (1034 kPa) design working pressure. Vent and drain connections with plugs shall be provided on each water box.

Refrigerant System

The YR chiller is equipped with a refrigerant metering device consisting of a fully modulating variable orifice controlled via the OptiView Control Center. This control ensures proper refrigerant flow to the evaporator over a wide range of operating conditions, including thermal storage applications and chilled water reset. Valve operation is programmable and can be customized for a specific application via the OptiView Control Center keypad.

The condenser shell shall be capable of storing the entire system refrigerant charge during servicing. Isolation from the rest of the system shall be by manually

Guide Specifications

operated isolation valves located at the inlet to the oil separator and outlet of the condenser (isolation valves optional). Additional valves shall be provided to facilitate removal of refrigerant charge from the system.

OPTIVIEW CONTROL CENTER

General – The chiller shall be controlled by a stand-alone microprocessor based control center. The chiller control panel shall provide control of chiller operation and monitoring of chiller sensors, actuators, relays and switches.

Control Panel – The control panel shall include a 10.4-in. diagonal color liquid crystal display (LCD) surrounded by "soft " keys which are redefined based on the screen displayed at that time. This shall be mounted in the middle of a keypad interface and installed in a locked enclosure. The screen shall detail all operations and parameters, using a graphical representation of the chiller and its major components. Panel verbiage shall be available in other languages as an option with English always available. Data shall be displayed in either English or Metric units. Smart Freeze Point Protection shall run the chiller at 36°F (2.22°C) leaving chilled water temperature, and not have nuisance trips on low water temperature. The sophisticated program and sensor shall monitor the chiller water temperature to prevent freeze-up. When needed, Hot Gas Bypass is available as an option. The panel shall display countdown timer messages so the operator knows when functions are starting and stopping. Every programmable point shall have a pop-up screen with the allowable ranges, so that the chiller can not be programmed to operate outside of its design limits.

The control panel shall be provided with a thermal ice storage control mode to enhance system performance during ice building operation. In the thermal storage control mode, the chiller shall stay at 100% load until the setpoint shutdown temperature is reached. To add greater operating flexibility and eliminate unnecessary chiller cycling, two different Low Water (Liquid) Temperature Restart Thresholds shall be programmable, one for the ice mode and one for the standard cooling mode. The chiller shall have the capability to remain in the standard control mode for temperatures between 20 to 70°F (-6.7 to 21.1°C) for applications involving a process cooling duty that requires leaving chilled liquid temperature setpoint control.

The chiller control panel shall also provide:

1. System operating information including:
 - a. Return and leaving chilled water temperature
 - b. Return and leaving condenser water temp.
 - c. Evaporator and condenser saturation temp.
 - d. Oil pressure at compressor and oil filter differential
 - e. Percent motor current
 - f. Evaporator and condenser saturation temp.
 - g. Compressor discharge temperature
 - h. Percent slide valve position
 - i. Operating hours
 - j. Number of unit starts
2. Digital programming of setpoints through the universal keypad including:
 - a. Leaving chilled water temperature
 - b. Percent current limit
 - c. Pull-down demand limiting
 - d. Six-week schedule for starting and stopping the chiller, pumps and tower
 - e. Remote reset temperature range
3. Status messages indicating:
 - a. System ready to start
 - b. System running
 - c. System lockout
 - d. System safety shutdown-manual restart
 - e. System cycling shutdown-auto restart
 - f. System startup
 - g. Start inhibit
4. The text displayed within the system status and system details field shall be displayed as a color coded message to indicate severity: red for safety fault, orange for cycling faults, yellow for warnings, and green for normal messages.
5. Safety shutdowns enunciated through the display and the status bar, and consist of system status, system details, day, time, cause of shutdown, and type of restart required. Safety shutdowns shall include:
 - a. Evaporator - low pressure
 - b. Evaporator - low pressure - smart freeze
 - c. Evaporator - transducer or leaving liquid probe
 - d. Evaporator - transducer or temperature sensor
 - e. Condenser - high pressure contacts open
 - f. Condenser - high pressure
 - g. Condenser - pressure transducer out of range
 - h. Auxiliary safety - contacts closed
 - i. Discharge - high temperature
 - j. Discharge - low temperature
 - k. Oil - low differential pressure
 - l. Oil or condenser transducer error
 - m. Oil - clogged filter

- n. Oil - high pressure
 - o. Control panel - power failure
 - p. Watchdog - software reboot
- 5.1. Safety shutdowns with a Solid State Starter (LCSSS) shall include:
- a. Shutdown - requesting fault data...
 - b. High instantaneous current
 - c. High phase (X) heatsink temperature - running
 - d. 105% motor current overload
 - e. Motor or starter - current imbalance
 - f. Phase (X) shorted SCR
 - g. Open SCR
 - h. Phase rotation
6. Cycling shutdowns enunciated through the display and the status bar, and consisting of system status, system details, day, time, cause of shutdown, and type of restart required.
- Cycling shutdowns shall include:
- a. Multiunit cycling - contacts open
 - b. System cycling - contacts open
 - c. Control panel - power failure
 - d. Leaving chilled liquid - low temperature
 - e. Leaving chilled liquid - flow switch open
 - f. Condenser - flow switch open
 - g. Motor controller - contacts open
 - h. Motor controller - loss of current
 - i. Power fault
 - j. Control panel - schedule
- 6.1 Cycling shutdowns with a Solid State Starter (LCSSS) shall include:
- a. Initialization failed
 - b. Serial communications
 - c. Requesting fault data
 - d. Stop contacts open
 - e. Power fault
 - f. Low phase (X) temperature sensor
 - g. Run signal
 - h. Invalid current scale selection
 - i. Phase locked loop
 - j. Low supply line voltage
 - k. High supply line voltage
 - l. Logic board processor
 - m. Logic board power supply
 - n. Phase loss
7. Security access to prevent unauthorized change of setpoints, to allow local or remote control of the chiller, and to allow manual operation of the variable orifice and slide valve position. Access shall be through ID and password recognition, which is defined by three different levels of user competence: view, operator, and service.
8. Trending data with the ability to customize points of once every second to once every hour. The panel shall trend up to 6 different parameters from a list of over 140, without the need of an external monitoring system.
9. The operating program stored in non-volatile memory (EPROM) to eliminate reprogramming the chiller due to AC power failure or battery discharge. Programmed setpoints shall be retained in lithium battery-backed RTC memory for a minimum of 11 years with power removed from the system.
10. A fused connection through a transformer in the compressor motor starter to provide individual over-current protected power for all controls.
11. A numbered terminal strip for all required field interlock wiring.
12. An RS-232 port to output all system operating data, shutdown/cycling message, and a record of the last 10 cycling or safety shutdowns to a field-supplied printer. Data logs to a printer at a set programmable interval. This data can be preprogrammed to print from 1 minute to 1 day.
13. The capability to interface with a building automation system to provide:
- a. Remote chiller start and stop
 - b. Remote leaving chiller liquid temperature adjust
 - c. Remote current limit setpoint adjust
 - d. Remote ready to start contacts
 - e. Safety shutdown contacts
 - f. Cycling shutdown contacts
 - g. Run contacts

COMPRESSOR MOTOR STARTER (OPTION, 200 - 600V)

The chiller manufacturer shall furnish a reduced-voltage Solid State Starter for the compressor motor. Starter shall be factory-mounted and wired on the chiller. The starter shall provide, through the use of silicon controlled rectifiers, a smooth acceleration of the motor without current transitions or transients. The starter enclosure shall be NEMA 1, with a hinged access door with lock and key. Electrical lugs for incoming power wiring shall be provided.

Guide Specifications

Standard features include: digital readout at the OptiView Control Center of the following:

Display Only:

- 3-phase voltage A, B, C
- 3-phase current A, B, C
- Input power (kW)
- kW Hours
- Starter Model
- Motor Run (LED)
- Motor Current % Full-load Amps
- Current Limit Setpoints
- Pulldown Demand Time Left

Programmable:

- Local Motor Current Limit
- Pulldown Demand Limit
- Pulldown Demand Time

Other features include: low-line voltage, 115-volt control transformer; three-leg sensing overloads; phase rotation and single-phase failure protection; high temperature safety protection, motor current imbalance and undervoltage safeties; open and close SCR protection; momentary power interruption protection. The LCSSS is cooled by a closed loop, fresh water circuit consisting of a water-to-water heat exchanger and 1/25 HP circulating pump. All interconnecting water piping is factory installed and rated for 150 PSIG working pressure. **Optional** unit-mounted circuit breaker includes

ground fault protection and provides 65,000 amp. Short circuit withstand rating in accordance with UL Standard 508. A non-fused disconnect switch is also available. Both options are padlockable.

REMOTE ELECTRO-MECHANICAL COMPRESSOR MOTOR STARTER (OPTIONAL)

A remote electro-mechanical starter of the R-1131 type shall be furnished for each compressor motor. The starter shall be furnished in accordance with the chiller manufacturer's starter specifications and as specified elsewhere in these specifications.

PORTABLE REFRIGERANT STORAGE/RECYCLING SYSTEM

A portable, self-contained refrigerant storage/recycling system shall be provided consisting of a refrigerant compressor with oil separator, storage receiver, water cooled condenser, filter drier and necessary valves and hoses to remove, replace and distill refrigerant. All necessary controls and safety devices shall be a permanent part of the system.

START-UP AND OPERATOR TRAINING

The chiller manufacturer shall include the services of a factory-trained, field service representative to supervise the final leak testing, charging and the initial start-up and concurrent operator instruction.

