



Start-Up and Service Instructions

SAFETY CONSIDERATIONS

Centrifugal and screw compressor liquid chillers are designed to provide safe and reliable service when operated within design specifications. When operating this equipment, use good judgment and safety precautions to avoid damage to equipment and property or injury to personnel.

Be sure you understand and follow the procedures and safety precautions contained in the chiller instructions as well as those listed in this guide.

⚠ DANGER

ONLY QUALIFIED Electrical Personnel familiar with the construction and operation of this equipment and the hazards involved should install, adjust, operate, or service this equipment.

READ AND UNDERSTAND this manual and other applicable manuals in their entirety before proceeding. Failure to observe this precaution could result in severe bodily injury or loss of life.

DO NOT install modification kits with power applied to the drive. Disconnect and lock out incoming power before attempting such installation or removal. Failure to observe this precaution could result in severe bodily injury or loss of life.

UNUSED WIRES in conduit must be grounded at both ends to avoid a possible shock hazard caused by induced voltages. Also, if a drive sharing a conduit is being serviced or installed; all drives using this conduit should be disabled to eliminate the possible shock hazard from cross-coupled motor leads. Failure to observe these precautions could result in bodily injury.

DO NOT VENT refrigerant relief valves within a building. Outlet from rupture disc or relief valve must be vented outdoors in accordance with the latest edition of ANSI/ASHRAE 15 (American National Standards Institute/American Society of Heating, Refrigerating, and Air Conditioning Engineers). The accumulation of refrigerant in an enclosed space can displace oxygen and cause asphyxiation.

PROVIDE adequate ventilation in accordance with ANSI/ASHRAE 15, especially for enclosed and low overhead spaces. Inhalation of high concentrations of vapor is harmful and may cause heart irregularities, unconsciousness, or death. Misuse can be fatal. Vapor is heavier than air and reduces the amount of oxygen available for breathing. Product causes eye and skin irritation. Decomposition products are hazardous.

DO NOT USE OXYGEN to purge lines or to pressurize a chiller for any purpose. Oxygen gas reacts violently with oil, grease, and other common substances.

NEVER EXCEED specified test pressures, VERIFY the allowable test pressure by checking the instruction literature and the design pressures on the equipment nameplate.

DO NOT USE air for leak testing. Use only refrigerant or dry nitrogen.

DO NOT VALVE OFF any safety device.

BE SURE that all pressure relief devices are properly installed and functioning before operating any chiller.

THERE IS A RISK OF INJURY OR DEATH by electrocution. High voltage may be present on the motor leads even though the motor is not running. Open the power supply disconnect before touching motor leads or terminals.

⚠ WARNING

DO NOT WELD OR FLAMECUT any refrigerant line or vessel until all refrigerant (*liquid and vapor*) has been removed from chiller. Traces of vapor should be displaced with dry air or nitrogen and the work area should be well ventilated. *Refrigerant in contact with an open flame produces toxic gases.*

DO NOT work on high-voltage equipment unless you are a qualified electrician.

DO NOT WORK ON electrical components, including control panels, switches, VFD, or oil heater until you are sure ALL POWER IS OFF and no residual voltage can leak from capacitors or solid-state components.

LOCK OPEN AND TAG electrical circuits during servicing. IF WORK IS INTERRUPTED, confirm that all circuits are deenergized before resuming work.

AVOID SPILLING liquid refrigerant on skin or getting it into the eyes. USE SAFETY GOGGLES. Wash any spills from the skin with soap and water. If liquid refrigerant enters the eyes, IMMEDIATELY FLUSH EYES with water and consult a physician.

DO NOT ATTEMPT TO REMOVE fittings, covers, etc., while chiller is under pressure or while chiller is running. Be sure pressure is at 0 psig (0 kPa) before breaking any refrigerant connection.

⚠ CAUTION

TO AVOID an electric shock hazard, verify that the voltage on the bus capacitors has discharged completely before servicing. Check the DC bus voltage at the Power Terminal Block by measuring between the +DC and -DC terminals, between the +DC terminal and the chassis, and between the -DC terminal and the chassis. The voltage must be zero for all three measurements.

THE USER is responsible to conform with all applicable local, national, and international codes. Failure to observe this precaution could result in damage to, or destruction of, the equipment.

THIS DRIVE contains ESD (Electrostatic Discharge) sensitive parts and assemblies. Static control precautions are required when installing, testing, servicing or repairing this assembly. Component damage may result if ESD control procedures are not followed. For static control procedures, reference Rockwell publication Guarding Against Electrostatic Damage, or any other applicable ESD protection handbook.

DO NOT alter the setting of any jumper. Failure to observe this precaution could result in damage to, or destruction of, the equipment.

USE OF power correction capacitors on the output of the drive can result in erratic operation of the motor, nuisance tripping, and/or permanent damage to the drive. Remove power correction capacitors before proceeding. Failure to observe this precaution could result in damage to, or destruction of, the equipment.

MOST CODES require that upstream branch circuit protection be provided to protect input power wiring. If fuses are chosen as the protection method, refer to the PowerFlex 750 user manual. Failure to observe this precaution could result in damage to, or destruction of, the equipment.

DO NOT route signal and control wiring with power wiring in the same conduit. This can cause interference with drive operation. Failure to observe this precaution could result in damage to, or destruction of, the equipment.

DISTRIBUTION SYSTEM short circuit capacity shall not exceed the rating of the drive. Failure to observe this precaution could result in damage to, or destruction of, the equipment.

DO NOT STEP on refrigerant lines. Broken lines can whip about and release refrigerant, causing personal injury.

DO NOT climb over a chiller. Use platform, catwalk, or staging. Follow safe practices when using ladders.

USE MECHANICAL EQUIPMENT (crane, hoist, etc.) to lift or move inspection covers or other heavy components. Even if components are light, use mechanical equipment when there is a risk of slipping or losing your balance.

BE AWARE that certain automatic start arrangements CAN ENGAGE THE VFD, TOWER FAN, OR PUMPS. Open the disconnect *ahead* of the VFD, tower fans, or pumps.

USE only repair or replacement parts that meet the code requirements of the original equipment.

PERIODICALLY INSPECT all valves, fittings, and piping for corrosion, rust, leaks, or damage.

CONTENTS

	Page
SAFETY CONSIDERATIONS	1
INTRODUCTION	2
ABBREVIATIONS AND EXPLANATIONS	2
Required Publications	2
Getting Assistance from Rockwell Automation	2
IDENTIFYING DRIVE COMPONENTS	2-5
Opening the VFD Access Door	3
Drive Assembly Catalog Number	3
Components and Physical Data	3
START-UP	6-8
Alternate Wire Lugs	6
Verify Installation	6
Configure the VFD	7
Commissioning the Unit	7
Check Internal Jumpers	7
SERVICE	9-29
Troubleshooting the Drive	9
• ICVC ALERT CODES	
• ICVC ALARM CODES	
• TEST EQUIPMENT NEEDED TO TROUBLESHOOT	
• VERIFYING THAT DC BUS CAPACITORS ARE DISCHARGED	
• HIGH TEMPERATURE ALARMS	
• MAIN CONTROL BOARD (MCB) COMPONENTS	
Checking Power Modules and Motor Input with Input Power Off	22
Servicing the Drive	23
• REMOVING THE DRIVE	
• RIGGING THE ENCLOSURE	
• REPLACING THE GATEWAY (A-B20-750-20COMM OPTION CARD)	
• CHILL PLATE FAN AND INTERNAL FAN REPLACEMENT	
Parts Identification and Location	26
APPENDIX A — WIRING SCHEMATICS	30-33
APPENDIX B — OPTIONAL BACNET COMMUNICATIONS WIRING	34-40

INTRODUCTION

The Carrier VFD option Start-Up and Service Manual is intended for trained and qualified service personnel, and is to be used during start up, operation, and maintenance of Rockwell/Allen-Bradley PF755L drive.

ABBREVIATIONS AND EXPLANATIONS

Frequently used abbreviations in this manual include:

CCM	— Chiller Control Module
DC	— Direct Current
DPI	— Drive Peripheral Interface
ENET	— Ethernet
ICVC	— International Chiller Visual Controller
IGBT	— Insulated Gate Bipolar Transistor
I/O	— Inputs/Outputs
IP	— Internet Protocol
IPWM	— Inverter Pulse Width Modulation
MCB	— Main Control Board
MOV	— Metal Oxide Varistor
PE	— Protective Earthing Conductor
SIO	— Sensor Input/Output
STS	— Status
VFD	— Variable Frequency Drive

Required Publications — The Carrier VFD option Start-Up and Service Manual must be used with the following manuals:

- Latest version of the PowerFlex 755 AC Drives manuals
- Latest revision of the Start-Up, Operation, and Maintenance Instructions for the 19XRV or 23XRV with PIC III Controls

Getting Assistance from Rockwell Automation — Contact the local Rockwell Automation sales office with any questions or problems relating to the products described in this manual. For technical support on drives between the hours of 7:00 am and 6:00 pm CST, M-F, call 1-262-512-8176. For information about after-hours phone support and on-site support call 1-800-800-0522.

Before calling, have the following information available from the Allen-Bradley data nameplate located inside the enclosure on the right wall. See Fig. 1.

- Allen-Bradley ID or CAT. NO.
- Carrier VFD Code
- Allen-Bradley serial number

 **Allen-Bradley**

ID No.: 21P-104773-4-0-0
Input Rating: 480VAC 454A 60Hz 3PH
Output Rating: 0-480VAC 477A 0-325Hz 3PH
Short Circuit Rating: 65kA, 480V Max. **Max. Ambient Temperature:** 40°C
Interrupt Capacity Rating: 100kAIC
Enclosure Type: TYPE 1
Coolant Type: Refrigerant R134a
Design Pressure: 185 PSIG
Carrier Part Number: 19XVR0445335A1F
VFD Serial Number: XXXXXXXXX
Carrier Dwg. Number: 19XV04021001
Mfd. On: 08-13-10 **ORDER NO:** 0001772838-00001
FAC.LOC.: 1100 **Made in USA for Carrier Corporation,
Syracuse, NY 13221-4808.**

Fig. 1 — Allen Bradley Data Nameplate

IDENTIFYING DRIVE COMPONENTS

A chiller control schematic and a VFD schematic are included in Appendix A.

WARNING

DC bus capacitors retain hazardous voltages after input power has been disconnected. After disconnecting input power, wait five (5) minutes for the DC bus capacitors to discharge and then check the voltage with a voltmeter rated for the DC bus voltage to ensure the DC bus capacitors are discharged before touching any internal components. Failure to observe this precaution could result in severe bodily injury or loss of life.

An isolated multimeter will be needed to measure DC bus voltage and to make resistance checks. The drive's DC bus capacitors retain hazardous voltages after input power has been disconnected.

Opening the VFD Access Door

⚠ WARNING

Before removing the drive enclosure, open access door and verify that the DC bus voltage has dropped to zero by checking the terminals behind the access door. Failure to observe this precaution could result in severe bodily injury or loss of life.

1. Using recommended screwdriver = 6.4 mm (0.25 in.) flat or T20 star, open access door. See Fig. 2.
2. Check to be sure that the voltage between DC+ and DC- and from each DC terminal to the chassis is zero before proceeding. See Fig. 3.

Drive Assembly Catalog Number — See Fig. 4 for an example Catalog Number.

Components and Physical Data — The 19XRV chillers use the Allen-Bradley PF755 Frame 6 drive for the 230-amp rated application (Carrier Part No. 19XRV0230...). See Fig. 5.

The Allen-Bradley PF755 Frame 7 drive is used for the 335-amp and 445-amp rated application (Carrier Part No. 19XVR0335... and 19XVR0445...). See Fig. 6.

See Fig. 7 for the dimensions of Frames 6 and 7 for 19XRV chillers.

The 23XRV chiller uses the Frame 7 drive for 335-amp and 455-amp rated applications (Carrier Part No. 23XVR0335... and 23XVR0445...). Frame 6 is not used.

See Fig. 8 for the dimensions of Frame 7 for 23XRV chillers.

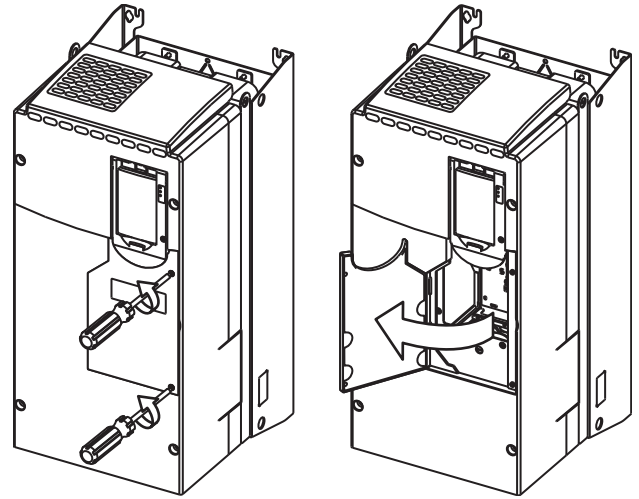

Fig. 2 — Opening Access Door

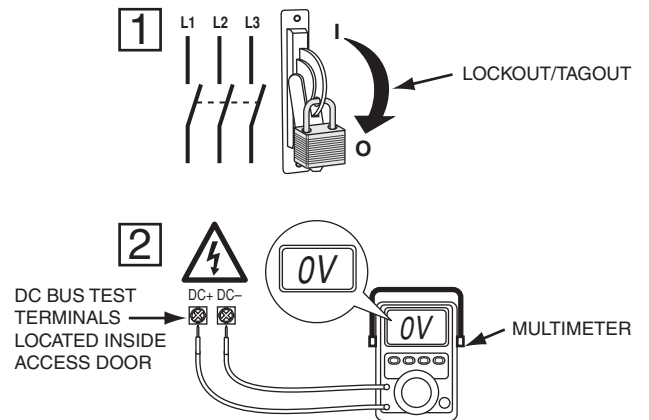
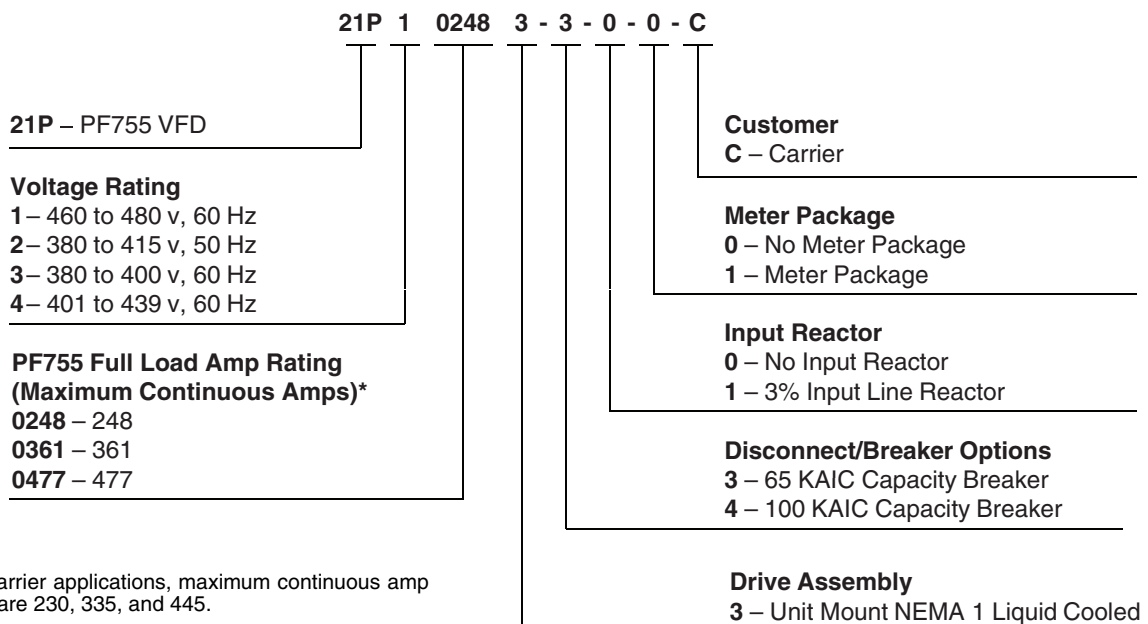
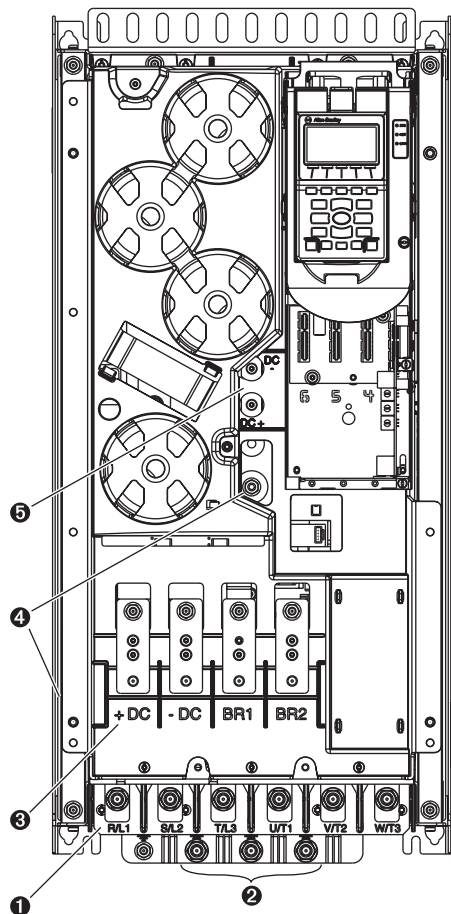

Fig. 3 — Check DC Bus Terminals



* For Carrier applications, maximum continuous amp ratings are 230, 335, and 445.

Fig. 4 — Drive Assembly Catalog Number Nomenclature



LEGEND

NO.	NAME	DESCRIPTION
1	Power Terminals	R/L1, S/L2, T/L3, U/T1, V/T2, W/T3
2	PE Grounding Studs	Terminating point to chassis ground for incoming motor shield
3	DC Bus and Brake Terminals	+DC, -DC, BR1, BR2
4	PE-A and PE-B	MOV and CMC Jumper Wires
5	DC+ and DC-	Bus Voltage Test Points

Fig. 5 — Frame 6 Drive Components

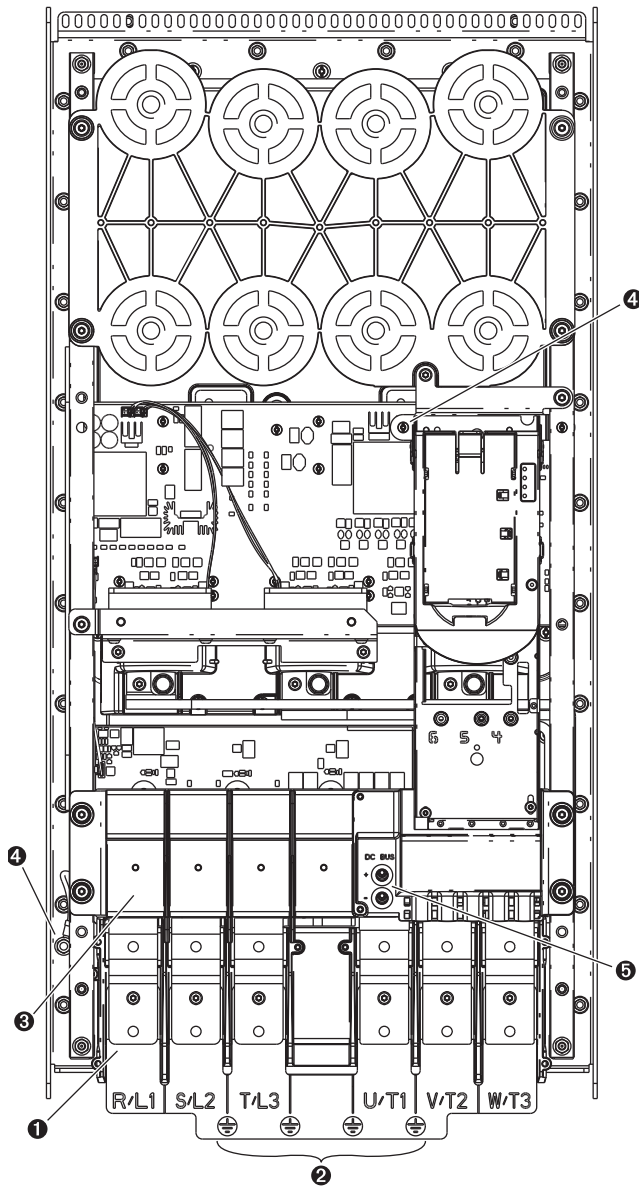

LEGEND

NO.	NAME	DESCRIPTION
1	Power Terminals	R/L1, S/L2, T/L3, U/T1, V/T2, W/T3
2	PE Grounding Studs	Terminating point to chassis ground for incoming motor shield
3	DC Bus and Brake Terminals	+DC, -DC, BR1, BR2
4	PE-A and PE-B	MOV and CMC Jumper Wires
5	DC+ and DC-	Bus Voltage Test Points

Fig. 6 — Frame 7 Drive Components

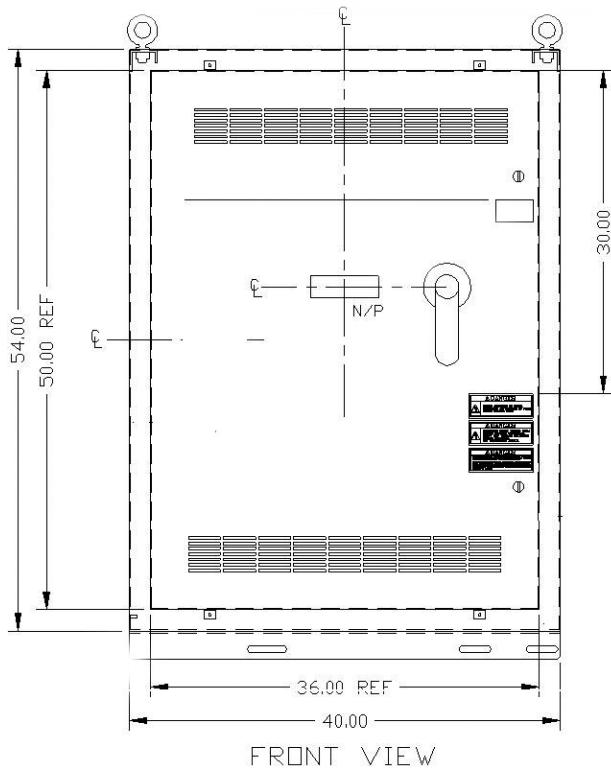

NOTE: Dimensions shown in inches.

Fig. 7 — 19XRV Enclosure Dimensions - Frames 6 and 7

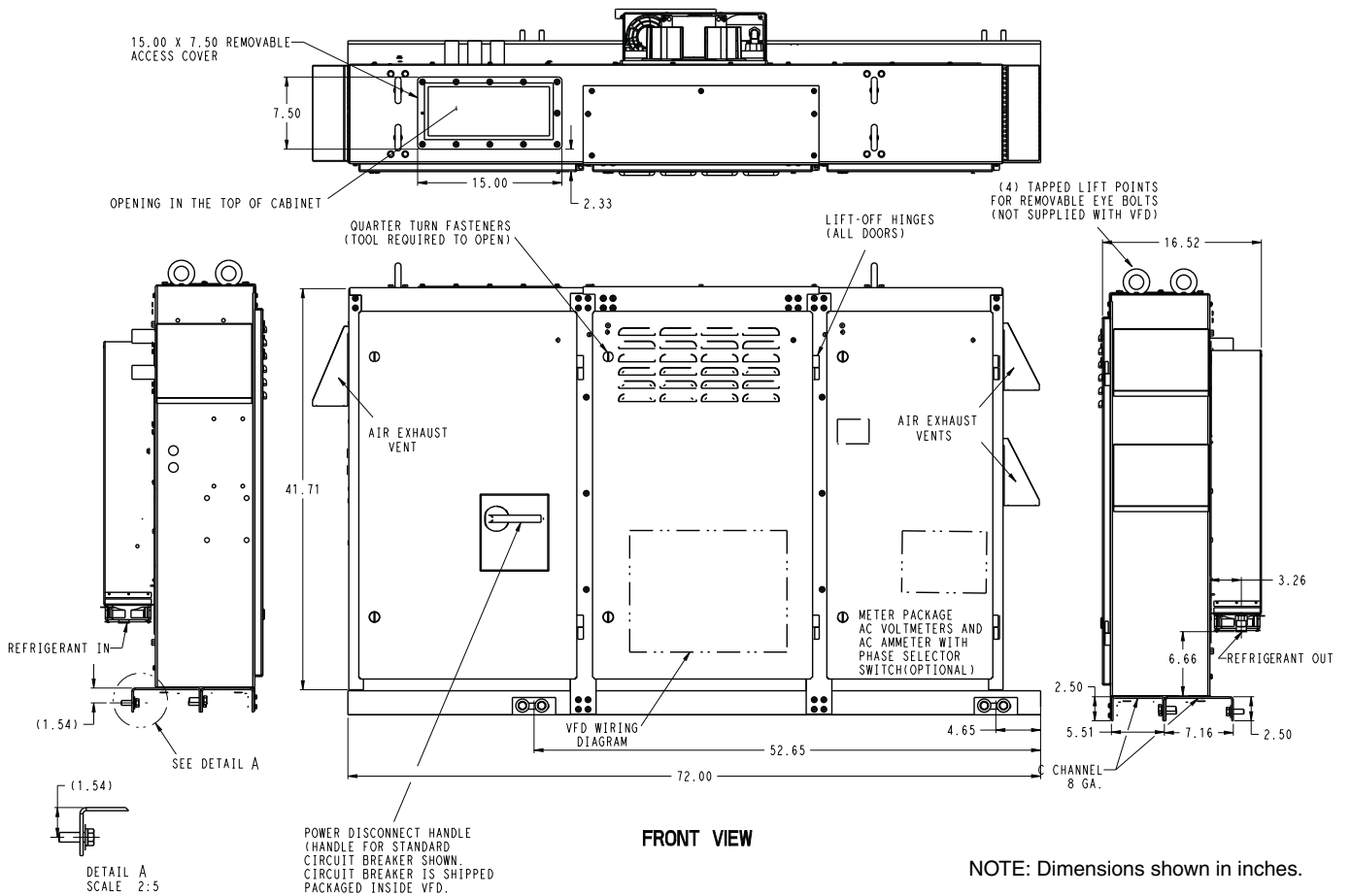

Fig. 8 — 23XRV Enclosure Dimensions — Frame 7

START-UP

⚠ DANGER

Internal components and circuit boards of the drive are live when the drive is connected to incoming power. Coming into contact with this voltage is extremely dangerous and will result in severe personal injury or death.

The motor terminals U, V, W and the DC-link/brake resistor terminals B+/R+, R- are live when the drive is connected to incoming power, even if the motor is not running.

Do not make any connections when the drive is connected to the incoming power.

After having disconnected the drive, wait until the indicators on the keypad go out (if no keypad is attached see the indicator through the keypad base). Wait 5 more minutes before doing any work on drive connections. Do not even open the cover before this time has expired.

Before connecting the drive to the incoming power, make sure that the switchgear enclosure door is closed.

⚠ WARNING

The control I/O-terminals are isolated from the mains potential. However, the relay outputs and other I/O terminals may have a dangerous control voltage present even when the drive is disconnected from incoming power. Coming into contact with this voltage could result in severe personal injury.

⚠ CAUTION

If other than refrigerant cooling is used, before connecting the drive to the incoming power, make sure that the coolant is circulating and has no leaks.

⚠ CAUTION

When working with the Drive Explorer, *never* use the Rotate function as the motor will immediately start and severe compressor damage could result.

Alternate Wire Lugs — In the case where the incoming power wire size does not fit the standard lug, alternate lugs may be used. See Table 1. Note that lugs rated for a higher current than the circuit breaker may be used.

Table 1 — Wire Lugs

CIRCUIT BREAKER	STANDARD ABB LUG	STANDARD LUG CABLE RANGE	ALTERNATE ABB LUG	ALTERNATE LUG CABLE RANGE
65 KAIC (Standard)	K6TJ	(3) 2/0 - 400 MCM	K6TH	(2) 250 - 500 MCM
100 KAIC (Optional)				

Verify Installation — Record the following job information:

1. Job Name
2. Job Number
3. City
4. State
5. Zip Code

Record the following nameplate information:

1. From the Allen-Bradley nameplate (Fig. 1) located inside the VFD enclosure:
 - a. Allen-Bradley ID or CAT NO.
 - b. Allen-Bradley Serial Number
 - c. Carrier Part Number
2. From the machine nameplate (Fig. 9) located inside the VFD enclosure:
 - a. Chiller Serial Number
 - b. Chiller Model
 - c. Motor rated load amps
 - d. Motor nameplate rpm
 - e. Motor nameplate kW
 - f. Motor nameplate voltage
 - g. Inverter PWM (pulse width modulation) frequency
 - h. Voltage
3. From the drive module label (Fig. 10) located on the drive module:
 - a. Model or Cat. Number
 - b. Serial Number
4. From the ICVC control panel screen:
 - a. Carrier Part Number and Revision
 - b. ICVC Software Number

Rockwell PowerFlex 755 drive start-up must be registered on the Rockwell website. Rockwell Registration site URL: <http://www.automation.rockwell.com/warp/default.asp>.

 Carrier <small>A United Technologies Company</small>	
MODEL NUMBER	
SERIAL NUMBER	
MACHINE NAMEPLATE SUPPLY DATA	
VOLTS/PHASE/HERTZ	
LOCKED ROTOR AMPS	
OVERLOAD TRIP AMPS	
MAX FUSE/CIRCUIT BREAKER SIZE	
MIN SUPPLY CIRCUIT AMPACITY	
MACHINE ELECTRICAL DATA	
MOTOR NAMEPLATE VOLTAGE	
COMPRESSOR 100% SPEED	
RATED LINE VOLTAGE	
RATED LINE AMPS	
RATED LINE KILOWATTS	
MOTOR RATED LOAD KW	
MOTOR RATED LOAD AMPS	
MOTOR NAMEPLATE AMPS	
MOTOR NAMEPLATE RPM	
MOTOR NAMEPLATE KW	
INVERTER PWM FREQUENCY	
SAFETY CODE CERTIFICATION	
<small>THE COMPRESSOR MOTOR CONTROLLER AND OVERLOAD PROTECTION MUST BE IN ACCORDANCE WITH CARRIER SPECIFICATION Z-403.</small>	
<small>19XV05008701 REV. 3</small>	

Fig. 9 — Machine Nameplate

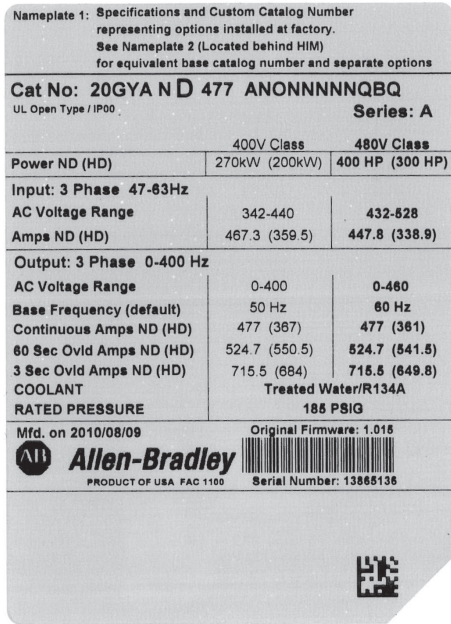

Fig. 10 — Drive Module Label

Configure the VFD — All configurations required by the VFD are supplied by the ICVC through the VFD Gateway. 19XRV, 23XRV Std Tier VFD can operate with PIC III ICVC and above. Any configuration changes necessary and possible are made on the ICVC screens. A complete set of configurations is transmitted to the VFD each time the controls are powered up.

The following is from the 19XRV, 23XRV PIC ICVC screen. Parameters in *italics>* are to be entered or confirmed at start-up. Parameters in **bold** are to be changed only after consulting with Carrier service engineering. See Table 2.

Table 2 — VFD Configurations

PARAMETER	DEFAULT VALUE
Motor Nameplate Voltage	460
Compressor 100% Speed	
Line Freq=60 Hz? (No=50)	Yes
<i>Rated Line Voltage*</i> †	460
<i>Rated Line Amps*</i> †	200
<i>Rated Line Kilowatts*</i> †	100
<i>Motor Rated Load kW*</i>	100
<i>Motor Rated Load Amps*</i>	200
<i>Motor Nameplate Amps</i>	100
<i>Motor Nameplate RPM</i>	3456
<i>Motor Nameplate kW</i>	100
Inverter PWM Frequency (0 = 4 kHz, 1 = 2 kHz)	1
Skip Frequency 1 (Hz)	102.0
Skip Frequency 2 (Hz)	102.0
Skip Frequency 3 (Hz)	102.0
Skip Frequency Band Line (Hz)	0.0
Voltage % Imbalance	10
Line Volt Imbalance Time (sec)†	10
Line Current % Imbalance†	40
Line Current Imbal Time (sec)†	10
Motor Current % Imbalance	40
Motor Current Imbal Time	10
Increase Ramp Time (sec)	30
Decrease Ramp Time (sec)	30
Single Cycle Dropout (DSABLE/ENABLE)	DSABLE

* Parameters marked with an * are not downloadable to the VFD but are used in other calculations and algorithms in the ICVC.

† Parameters marked with a † may not be available with PIC-IV ICVC.

NOTES:

- Parameters in *italics* are to be entered or confirmed at start-up.
- Parameters in **bold** are to be changed only after consultation with service engineering.

Commissioning the Unit — The commission procedure is as follows:

- If the chiller has been stored outdoors, allow at least 24 hours room temperature stabilization prior to commissioning. Ensure any condensation that occurs as a result of the ambient temperature is allowed to evaporate.
- Enter parameters in the VFD_CONF screen.
- Install surge suppression devices if required.
- Review the power wiring and grounding to ensure that it has been properly connected.
- Visually examine the inside of the drive enclosure to:
 - Look for signs of corrosion or moisture residue.
 - Remove any dirt or debris.
 - Make sure all vents are clear.
- Apply power to the drive and take thermal measurements of the capacitor bank and power connections. Do this again before start-up.
- Measure and record the incoming line voltage. Line-to-line voltages should be balanced within 3% as calculated by Rockwell's procedure below:
Measure voltages phase-to-phase and phase-to-ground.

V_{max} = Maximum measured phase-to-phase voltage
(A to B, B to C, C to A)

V_{min} = Minimum measured phase-to-phase voltage
Imbalance Calculation Formula

$$V_{avg} = \frac{(V_{AB} + V_{BC} + V_{CA})}{3}$$

$$\text{Imbalance \%} = \frac{(V_{max} - V_{min}) \times 100}{V_{avg}}$$

- Take a final thermal measurement of the capacitor bank and power after finalizing the installation to ensure all connections are good.
- If a ground fault occurs, then do the following:
 - Check for a ground in the motor or motor wiring.
 - Check for damage to wiring insulation and that wiring is dry.
 - Verify the motor wiring is separated from ground and there is no connection between phases.
 - Check for failed IGBTs.
- If an Overcurrent fault occurs, then do the following:
 - Check for excessive load and verify load limit settings on the ICVC.
 - Check motor and wiring insulation.
 - Check parameter settings on VFD_CONF screen in the ICVC.

Check Internal Jumpers — On the Main VFD Control board there are two jumpers labeled J1 HARDWARE ENABLE and J2 SAFETY ENABLE. J1 should be removed and J2 should be in place. See Fig. 11.

There are two jumper wires that connect a particular terminal to chassis ground. The MOV and AC EMI jumper should be connected to the PE-A terminal. The COMMON MODE CAPACITORS to GROUND jumper should be connected to a standoff rather than the PE-B terminal.

Use the recommended tools as follows when connecting jumper wires in Frame 6 and in Frame 7:

- Recommended torque (screws and nuts) = 1.36 N·m (120.0 lb·in)
- Recommended hex socket = 7 mm
- Recommended screwdriver = T20 star type.

See Fig. 12A and Fig. 12B for the correct positions of the jumpers.

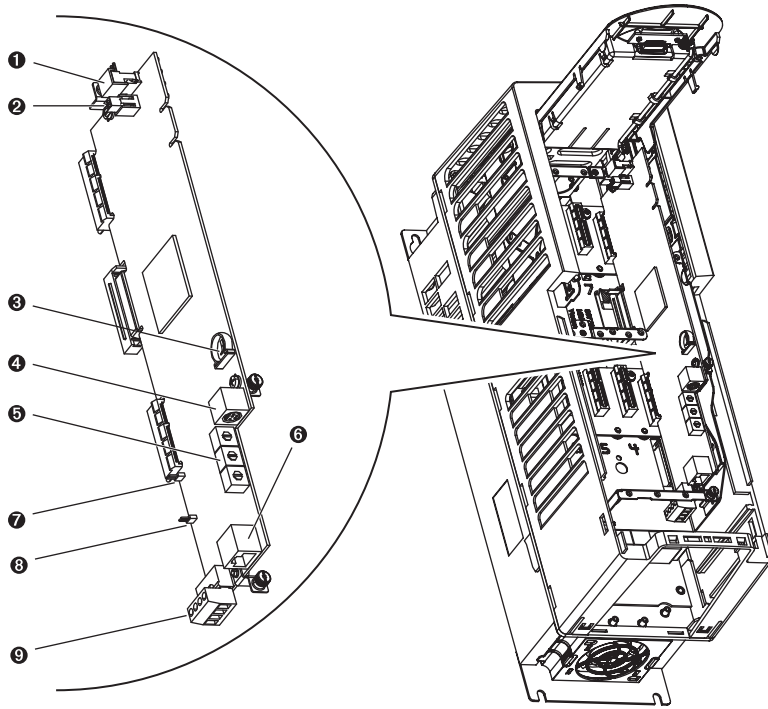

LEGEND

NO.	NAME	DESCRIPTION
1	HIM Connector	DPI Port 1 (HIM Cradle) connection.
2	Fan Connector	Power supply for internal cooling fan (Frames 2 and 3).
3	Battery Receptacle	User installed CR1220 lithium coin cell battery provides power to the Real Time Clock (Optional, not supplied).
4	DPI Port 2	Cable connection for handheld and remote HIM options.
5	Embedded EtherNet/IP Address Selectors	Rotary switches for setting lowest octet of EtherNet address (forces address to 192.168.1.xxx).
6	Embedded EtherNet/IP Connector	Network cable connection.
7	Jumper J2 SAFETY	Safety enable jumper. Removed when safety option is installed. For additional information, refer to the Check Internal Jumpers section on page 7.
8	Jumper J1 ENABLE	Hardware enable jumper. Removed when a hardware enable configuration is utilized. For additional information, refer to the Check Internal Jumpers section on page 7.
9	TB1	I/O terminal block.

TB1 I/O Terminal Designations

FIXED I/O	TERMINAL	NAME	DESCRIPTION
	Di 0ac	Digital Input 120V AC	Connections for AC power supply.
	Di C	Digital Input Common	Digital input common
	Di 0dc	Digital Input 24V DC	Connections for DC power supply.
	+24V	+24 Volt Power	Connections for drive supplied 24V power.
	24VC	24 Volt Common	

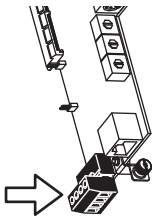

IMPORTANT: Wiring to pluggable terminal block connectors should be supported by wire ties or other means to help prevent unintentional disconnection.

Fig. 11 — PF755 Main Control Board

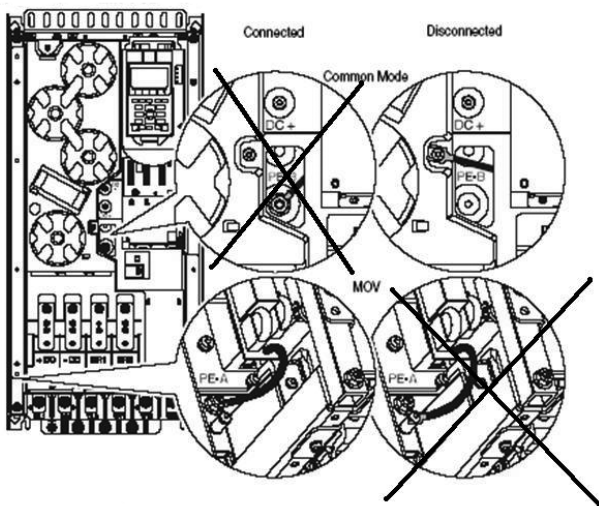

Fig. 12A — Jumper Wire Locations — Frame 6

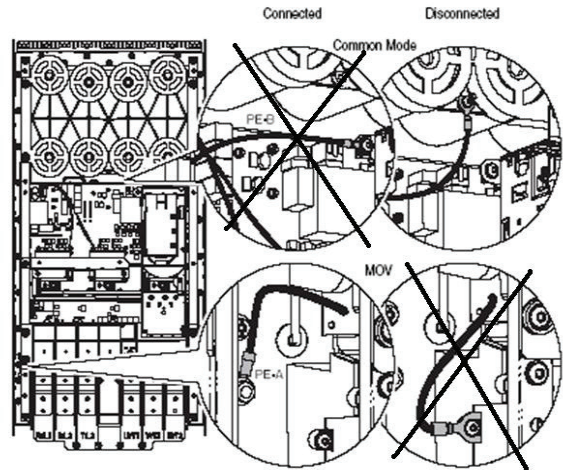

Fig. 12B — Jumper Wire Locations — Frame 7

SERVICE

⚠ WARNING

DC bus capacitors retain hazardous voltages after input power has been disconnected. After disconnecting input power, wait five (5) minutes for the DC bus capacitors to discharge and then check the voltage with a voltmeter to ensure the DC bus capacitors are discharged before touching any internal components. Failure to observe this precaution could result in severe bodily injury or loss of life.

Troubleshooting the Drive — The drive can display two kinds of error codes on the ICVC called the Alert and Alarm codes. These codes signal a problem detected during self tuning or drive operation. Note the following differences between Carrier and Allen-Bradley terminology:

- A warning message on the ICVC is an ALERT.
- The same warning viewed with Rockwell Drive Explorer is a VFD ALARM.
- A failure resulting in a shutdown is seen as an ALARM on the ICVC and as a VFD FAULT when viewed with Drive Explorer.

CONDITION CODES

ICVC ALERT = VFD ALARM

ICVC ALARM = VFD FAULT

See Tables 3-6 and Fig. 13.

ICVC ALERT CODES — An alert condition is indicated by a message at the top of the ICVC default screen. In addition, an exclamation point (!) will appear next to any affected point on an ICVC display screen. The drive will continue to operate during the alert condition. Investigate the cause of the alert to ensure it does not lead to a fault condition. The alert code will automatically be cleared from the ICVC when the condition causing the alert no longer exists. See Table 4.

ICVC ALARM CODES — An alarm condition is also indicated by a message at the top of the ICVC default screen. If an alarm occurs, the drive coasts to stop. The STS (status) light on the drive will turn from Green to Red or Yellow (see Table 3). The detected fault message is maintained on the display until it is cleared by pressing the RESET softkey. See Table 5.

TEST EQUIPMENT NEEDED TO TROUBLESHOOT — An isolated multimeter adequately rated for the DC bus voltage will be needed to measure DC bus voltage and to make resistance checks. Note that dedicated troubleshooting test points are not provided.

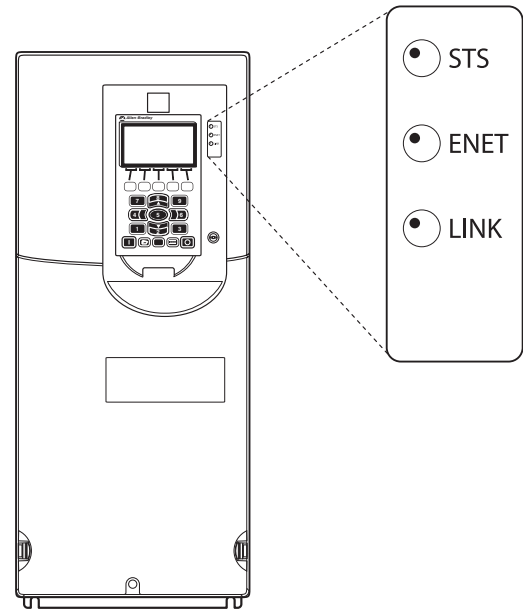

Fig. 13 — Drive Status Indicator

Table 3 — Drive Status Indicator Descriptions

NAME	COLOR	STATE	DESCRIPTION
STS (Status)	Green	Flashing	Drive ready but not running, and no faults are present.
		Steady	Drive running, no faults are present.
	Yellow	Flashing	Drive is not running. A type 2 (non-configurable) alarm condition exists and the drive cannot be started.
		Steady	Drive is not running, a type 1 alarm condition exists. The drive can be started.
	Red	Flashing	A major fault has occurred. Drive cannot be started until fault condition is cleared.
		Steady	A non-resettable fault has occurred.
Red/Yellow	Flashing Alternately	A minor fault has occurred. When running, the drive continues to run. System is brought to a stop under system control. Fault must be cleared to continue. Use parameter 950 [Minor Flt Config] to enable. If not enabled, acts like a major fault.	
Green/Red	Flashing Alternately	Drive is flash updating.	
ENET	None (Unlit)	Off	Adapter and/or network is not powered, adapter is not properly connected to the network, or adapter needs an IP address.
	Red	Flashing	An EtherNet/IP connection has timed out.
		Steady	Adapter failed the duplicate IP address detection test.
	Red/Green	Flashing Alternately	Adapter is performing a self-test.
	Green	Flashing	Adapter is properly connected but is not communicating with any devices on the network.
Steady		Adapter is properly connected and communicating on the network.	
LINK	None (Unlit)	Off	Adapter is not powered or is not transmitting on the network.
	Green	Flashing	Adapter is properly connected and transmitting data packets on the network.
		Steady	Adapter is properly connected but is not transmitting on the network.

NOTES:

1. A Type 1 alarm indicates that a condition exists. Type 1 alarms are user configurable.

2. A Type 2 alarm indicates that a configuration error exists and the drive cannot be started. Type 2 alarms are not configurable.

VERIFYING THAT DC BUS CAPACITORS ARE DISCHARGED — The drive's DC bus capacitors retain hazardous voltages after input power has been disconnected. Perform the following steps before touching any internal components:

1. Turn off and lock out input power. Wait five minutes.
2. Verify that there is no voltage at the drive's input power terminals.
3. Measure the DC bus potential with a voltmeter while standing on a non-conductive surface and wearing insulated gloves (1000 V). Measure the DC bus potential. See Fig. 5 for the 248-amp drive and Fig. 6 for the 361 and 477-amp drives. The voltage between DC+ and DC-, and from each DC terminal to the chassis must be zero before proceeding.
4. Once the drive has been serviced, reapply input power.

HIGH TEMPERATURE ALARMS — Coolant flow through the cold plate is controlled by an orifice in the refrigerant line leaving the cold plate. The orifice looks like one of the O-ring face seal connectors and in fact is used as one of the connections on the coolant tubing. The difference is that the passage through the fitting is 0.375 in. (9.5 mm). If the orifice is present and condenser liquid flow is present, the liquid will flash to cooler temperature at the orifice. This temperature difference is great enough to be easily felt.

MAIN CONTROL BOARD (MCB) COMPONENTS — Figure 14 shows the drive module with the cover removed. To access the control boards, loosen the screw on the face of the keypad mount and swing the keypad mount upward.

The components on the main control board (MCB) are shown in Fig. 15. Note the location of the terminals labeled MCB I/O. The high pressure switch is wired to these terminals as shown in Fig. 16. In the event of a high condenser pressure alarm, the connections at these terminals should be checked and tightened if necessary.

A typical wiring schematic is shown in Appendix A.

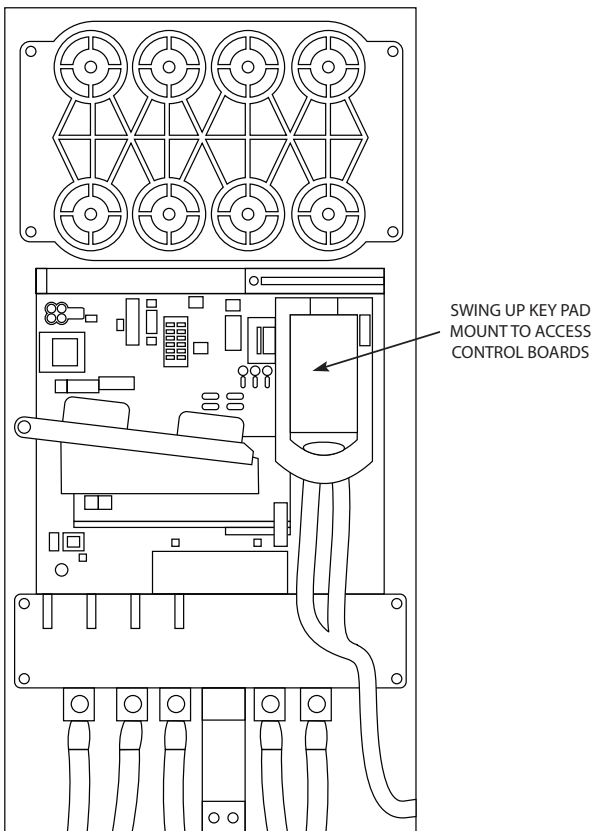

Fig. 14 — Drive Module with Cover Removed

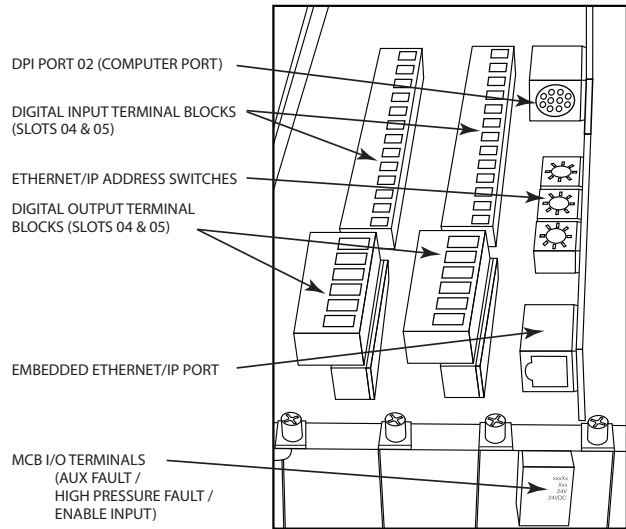
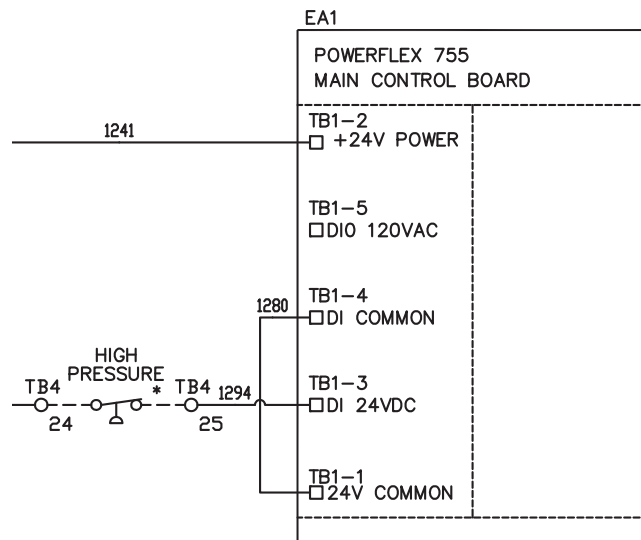

Fig. 15 — MCB (Main Control Board) Components



*Located outside of starter; connected by field wiring.

Fig. 16 — High Pressure Switch Wiring

Table 4 — ICVC Alert Codes

PRE-START ALERTS: These alerts only delay start-up. When alert is corrected, the start-up will continue. No reset is necessary.

ICVC FAULT STATE	PRIMARY MESSAGE	SECONDARY MESSAGE	PRIMARY CAUSE	ADDITIONAL CAUSE/REMEDY
100	PRESTART ALERT	STARTS LIMIT EXCEEDED	100→Excessive compressor starts (8 in 12 hours).	Depress the RESET softkey if additional start is required. Reassess start-up requirements.
101	PRESTART ALERT	HIGH BEARING TEMPERATURE	101→Comp Thrust Brg Temp [VALUE] exceeded limit of [LIMIT]*.	Check oil heater for proper operation. Check for low oil level, partially closed oil supply valves, clogged oil filters. Check the sensor wiring and accuracy. Check Comp Thrust Brg Alert setting in SETUP1 screen.
102	PRESTART ALERT	HIGH MOTOR TEMPERATURE	102→Comp Motor Winding Temp [VALUE] exceeded limit of [LIMIT]*.	Check motor sensors for wiring and accuracy. Check motor cooling line for proper operation, or restrictions. Check for excessive starts within a short time span. Check Comp Motor Temperature Override setting in SETUP1 screen.
103	PRESTART ALERT	HIGH DISCHARGE TEMP	103→Comp Discharge Temp [VALUE] exceeded limit of [LIMIT]*.	Allow discharge sensor to cool. Check sensor wiring and accuracy. Check for excessive starts. Check Comp Discharge Alert setting in SETUP1 screen.
104	PRESTART ALERT	LOW REFRIGERANT TEMP	104→Evaporator Refrig Temp [VALUE] exceeded limit of [LIMIT]*.	Check transducer wiring and accuracy. Check for low chilled fluid supply temperatures. Check refrigerant charge. Check Refrig Override Delta T in SETUP1 screen.
105	PRESTART ALERT	LOW OIL TEMPERATURE	105→Oil Sump Temp [VALUE] exceeded limit of [LIMIT]*.	Check oil heater contactor/relay and power. Check oil level and oil pump operation.
106	PRESTART ALERT	HIGH CONDENSER PRESSURE	106→Condenser Pressure [VALUE] exceeded limit of [LIMIT]*.	Check transducer wiring and accuracy. Check for high condenser water temperatures. Check high condenser pressure switch wiring.
107	PRESTART ALERT	LOW LINE VOLTAGE	107→Percent Line Voltage [VALUE] exceeded limit of [LIMIT]*.	Check voltage supply. Check voltage transformers and switch gear. Consult power utility if voltage is low.
108	PRESTART ALERT	HIGH LINE VOLTAGE	108→Percent Line Voltage [VALUE] exceeded limit of [LIMIT]*.	Check voltage supply. Check power transformers. Consult power utility if voltage is high.
109	PRESTART ALERT	GUIDE VANE CALIBRATION	109→Actual Guide Vane Pos Calibration Required Before Startup.	Press STOP button on ICVC and perform Guide Vane Calibration in Controls Test screen. Check guide vane actuator feedback potentiometer.
110	PRESTART ALERT	HIGH RECTIFIER TEMP	110→Rectifier Temperature [VALUE] exceeded limit of [LIMIT]*.	Check that VFD refrigerant isolation valves are open. Check VFD refrigerant cooling solenoid and refrigerant strainer. Check for proper VFD cooling fan operation and blockage.
111	PRESTART ALERT	HIGH INVERTER TEMP	111→Inverter Temperature [VALUE] exceeded limit of [LIMIT]*.	Check that VFD refrigerant isolation valves are open. Check VFD refrigerant cooling solenoid and refrigerant strainer. Check for proper VFD cooling fan operation and blockage.

*[LIMIT] is shown on the ICVC as temperature, pressure, voltage, etc., predefined or selected by the operator as an override or an alert. [VALUE] is the actual pressure, temperature, voltage, etc., at which the control tripped.

Table 4 — ICVC Alert Codes (cont)

NORMAL RUN WITH OVERRIDES

ICVC FAULT STATE	PRIMARY MESSAGE	SECONDARY MESSAGE	PRIMARY CAUSE	ADDITIONAL CAUSE/REMEDY
120	RUN CAPACITY LIMITED	HIGH CONDENSER PRESSURE	120→Condenser Pressure [VALUE] exceeded limit of [LIMIT]*.	Check condenser water pump operation. Check for high condenser water temperatures or low flow rate. Verify that isolation valves are open. Check Cond Press Override setting in SETUP1.
121	RUN CAPACITY LIMITED	HIGH MOTOR TEMPERATURE	121→Comp Motor Winding Temp [VALUE] exceeded limit of [LIMIT]*.	Check for closed valves or restriction in motor cooling lines. Check for closed refrigerant isolation valves. Check Comp Motor Temp Override setting in SETUP1.
122	RUN CAPACITY LIMITED	LOW EVAP REFRIG TEMP	122→Evaporator Refrig Temp [VALUE] exceeded limit of [LIMIT]*.	Check refrigerant charge. Check that optional cooler liquid line isolation valve is fully open. Check for excessive condenser flow or low chilled water flow. Check for low entering cooler temperature. Check that condenser inlet and outlet water nozzles are piped correctly. Check for waterbox division plate gasket bypass.
123	RUN CAPACITY LIMITED	HIGH COMPRESSOR LIFT	123→Surge Prevention Override: Lift Too High For Compressor	Check for high condenser water temperature or low suction temperature. Check for high Evaporator or Condenser approaches. Check surge prevention parameters in OPTIONS screen.
124	RUN CAPACITY LIMITED	MANUAL GUIDE VANE TARGET	124→Run Capacity Limited: Manual Guide Vane Target.	Target Guide Vane Position has been forced in the COMPRESS screen. Select and RELEASE force to return to normal (automatic) operation.
125	RUN CAPACITY LIMITED	LOW DISCHARGE SUPERHEAT	No Alert message.	Check for oil loss or excess refrigerant charge. Verify that the valves in the oil reclaim lines are open.
126	RUN CAPACITY LIMITED	HIGH RECTIFIER TEMP	126→Rectifier Temperature [VALUE] exceeded limit of [LIMIT]*.	Check Rectifier Temp Override in SETUP1 screen. Check that VFD refrigerant isolation valves are open. Check VFD refrigerant cooling solenoid. Check for proper VFD cooling fan operation and blockage.
127	RUN CAPACITY LIMITED	MANUAL SPEED CONTROL	No Alert message.	Chiller is not in automatic temperature control.
128	RUN CAPACITY LIMITED	HIGH INVERTER TEMP	128→Inverter Temperature [VALUE] exceeded limit of [LIMIT]*.	Check Inverter Temp Override in SETUP1 screen. Check that VFD refrigerant isolation valves are open. Check VFD refrigerant cooling solenoid. Check for proper VFD cooling fan operation and blockage.

*[LIMIT] is shown on the ICVC as the temperature, pressure, voltage, etc., set point predefined or selected by the operator as an override, alert, or alarm condition. [VALUE] is the actual pressure, temperature, voltage, etc., at which the control tripped.

Table 4 — ICVC Alert Codes (cont)

CHILLER ALERTS

ICVC FAULT STATE	PRIMARY MESSAGE	SECONDARY MESSAGE	PRIMARY CAUSE	ADDITIONAL CAUSE/REMEDY
140	SENSOR ALERT	LEAVING COND WATER TEMP	140→Sensor Fault: Check Leaving Cond Water Sensor.	Check sensor resistance or voltage drop. Check for proper wiring.
141	SENSOR ALERT	ENTERING COND WATER TEMP	141→Sensor Fault: Check Entering Cond Water Sensor.	Check sensor resistance or voltage drop. Check for proper wiring.
142	LOW OIL PRESSURE ALERT	CHECK OIL FILTER	142→Low Oil Pressure Alert. Check Oil Filter.	Check for partially or closed shut-off valves. Check oil filter. Check oil pump and power supply. Check oil level. Check for foaming oil at start-up. Check transducer wiring and accuracy.
143	AUTORESTART PENDING	LINE CURRENT IMBALANCE	143→Line Current Imbalance: Check VFD Fault History for Values.	Power loss has been detected in any phase. Chiller automatically restarting.
144	AUTORESTART PENDING	LINE VOLTAGE DROP OUT	144→Single Cycle Line Voltage Dropout.	A drop in line voltage has been detected within 2 voltage cycles. Chiller automatically restarting if Auto Restart is enabled in OPTIONS screen.
145	AUTORESTART PENDING	HIGH LINE VOLTAGE	145→High Percent Line Voltage [VALUE].	Check phase to phase and phase to ground line power.
146	AUTORESTART PENDING	LOW LINE VOLTAGE	146→Low Percent Line Voltage [VALUE].	Check phase to phase and phase to ground line power.
147	AUTORESTART PENDING	VFD MODULE RESET	147→VFD Module Power-On Reset When Running.	VFD Module has detected a hardware fault due to electrical noise, power loss or software and has reset. Chiller automatically restarting. Check for power loss and sources of electromagnetic interference.
148	AUTORESTART PENDING	POWER LOSS	148→Control Power-Loss When Running.	Check 24 vac control power supply to ICVC.
149	SENSOR ALERT	HIGH DISCHARGE TEMP	149→Comp Discharge Temp [VALUE] Exceeded Limit of [LIMIT]*.	Check sensor resistance or voltage drop. Check for proper wiring. Check for proper inlet guide vane and optional diffuser actuator operation. Check for proper condenser flow and temperature. Check for high lift or low load. Check for fouled tubes or noncondensables in the chiller.
150	SENSOR ALERT	HIGH BEARING TEMPERATURE	150→Comp Thrust Brg Temp [VALUE] exceeded limit of [LIMIT]*.	Check sensor resistance or voltage drop. Check for proper wiring. Check for partially closed service valves. Check oil cooler TXV. Check oil level and oil temperature.
151	CONDENSER PRESSURE ALERT	PUMP RELAY ENERGIZED	151→High Condenser Pressure [VALUE]: Pump Energized to Reduce Pressure.	Check sensor wiring and accuracy. Check condenser flow and water temperature. Check for fouled tubes. This alarm is not caused by the High Pressure Switch.
152	RECYCLE ALERT	EXCESSIVE RECYCLE STARTS	152→Excessive recycle starts.	Chiller load is too low to keep compressor on line and there has been more than 5 starts in 4 hours. Increase chiller load, adjust hot gas bypass, increase RECYCLE RESTART DELTA T from SETUP1 Screen.
153	no message: ALERT only	no message; ALERT only	153→Lead/Lag Disabled-Config: Duplicate Chiller Address.	Illegal chiller address configuration in Lead/Lag screen. Both chillers require a different address.
154	POTENTIAL FREEZE-UP	COND PRESS/TEMP TOO LOW	154→Condenser freeze up prevention.	The condenser pressure transducer is reading a pressure that could freeze the condenser tubes. Check for condenser refrigerant leaks. Check fluid temperature. Check sensor wiring and accuracy. Place the chiller in PUMPDOWN mode if the vessel is evacuated.
155	OPTION SENSOR FAULT	REMOTE RESET SENSOR	155→Sensor Fault/Option Disabled: Remote Reset Sensor.	Check sensor resistance or voltage drop. Check for proper wiring to CCM connector J4.
156	OPTION SENSOR FAULT	AUTO CHILLED WATER RESET	156→Sensor Fault/Option Disabled: Auto Chilled Water Reset.	Check sensor resistance or voltage drop. Check for proper wiring to CCM connector J5.
157	OPTION SENSOR FAULT	AUTO DEMAND LIMIT INPUT	157→Sensor Fault/Option Disabled: Auto Demand Limit Input.	Check sensor resistance or voltage drop. Check for proper wiring to CCM connector J5.
158	SENSOR ALERT	SPARE TEMPERATURE #1	158→Spare Temperature 1 [VALUE] exceeded limit of [LIMIT]*.	Check sensor resistance or voltage drop. Check for proper wiring to CCM connector J4. Check Spare Temp #1 Limit in SETUP1 screen.

*[LIMIT] is shown on the ICVC as the temperature, pressure, voltage, etc., set point predefined or selected by the operator as an override, alert, or alarm condition. [VALUE] is the actual pressure, temperature, voltage, etc., at which the control tripped.

Table 4 — ICVC Alert Codes (cont)

CHILLER ALERTS (cont)

ICVC FAULT STATE	PRIMARY MESSAGE	SECONDARY MESSAGE	PRIMARY CAUSE	ADDITIONAL CAUSE/REMEDY
159	SENSOR ALERT	SPARE TEMPERATURE #2	159→Spare Temperature 2 [VALUE] exceeded limit of [LIMIT]*.	Check sensor resistance or voltage drop. Check for proper wiring to CCM connector J4. Check Spare Temp #2 Limit in SETUP1 screen.
161	LOSS OF COMMUNICATION	WITH WSM	161→WSM Cool Source — Loss of Communication.	Check settings in WSMDEFME screen. Check CCN communications link with WSM (Water System Manager) Module. Check Supervisory Part of WSM.
162	SENSOR ALERT	EVAPORATOR APPROACH	162→Evaporator Approach [VALUE] Exceeded Limit of [LIMIT]*.	Check that refrigerant charge level is adequate, waterbox division plate gaskets are sealing, evaporator tubes are not fouled and that oil reclaim system is working. Check sensor resistance or voltage drop. Check for proper wiring. Check Evap Approach Alert setting in SETUP1 screen.
163	SENSOR ALERT	CONDENSER APPROACH	163→Condenser Approach [VALUE] Exceeded Limit of [LIMIT]*.	Check sensors resistance or voltage drop. Check for proper wiring. Check Cond Approach Alert setting in SETUP1 screen. Check for noncondensable gas in the condenser. Check that the condenser tubes are not fouled.
164	VFD SPEED ALERT	LOW VFD SPEED	164→Actual VFD Speed exceeded limit of Target VFD Speed -10%.	Actual VFD Speed on COMPRESS screen must be at least 90% of Target VFD Speed.
165	AUTORESTART PENDING	LOW DC BUS VOLTAGE	165→Low DC Bus Voltage: [VALUE] Exceeded Limit of [LIMIT]*.	Verify phase to phase and phase to ground line voltage.
166	AUTORESTART PENDING	HIGH DC BUS VOLTAGE	166→High DC Bus Voltage: [VALUE] Exceeded Limit of [LIMIT]*.	Verify phase to phase and phase to ground line voltage. Monitor AC line for high transient voltage conditions.
167	SYSTEM ALERT	HIGH DISCHARGE TEMP	167→Comp Discharge Temp [VALUE] exceeded limit of [LIMIT]*.	Check sensor resistance or voltage drop. Check for proper wiring. Check for excessive starts. Check Comp Discharge Alert setting in SETUP1 screen.
168	SENSOR ALERT	HUMIDITY SENSOR INPUT	168→Sensor Fault: Check Humidity Sensor Input Sensor.	Check humidity sensor wiring on CCM connectors J3 and J5. CCM switch SW2-1 must be in "OFF" position. Check Humidity Sensor Input in Controls Test.

*[LIMIT] is shown on the ICVC as the temperature, pressure, voltage, etc., set point predefined or selected by the operator as an override, alert, or alarm condition. [VALUE] is the actual pressure, temperature, voltage, etc., at which the control tripped.

Table 5 — ICVC Alarm Codes

CHILLER PROTECTIVE LIMIT FAULTS

ICVC FAULT STATE	PRIMARY MESSAGE	SECONDARY MESSAGE	PRIMARY CAUSE	ADDITIONAL CAUSE/REMEDY
200	PROTECTIVE LIMIT	RECTIFIER POWER FAULT	200→Rectifier Power Fault: Check VFD Status.	Malfunction within VFD Power Module. Contact Carrier Service.
201	PROTECTIVE LIMIT	INVERTER POWER FAULT	201→Inverter Power Fault: Check VFD Status.	Malfunction within VFD Power Module. Contact Carrier Service.
202	PROTECTIVE LIMIT	MOTOR AMPS NOT SENSED	202→Motor Amps Not Sensed — Average Load Current [VALUE].	Check main circuit breaker for trip. Increase Current % Imbalance in VFD_CONF screen.
203	FAILURE TO START	MOTOR ACCELERATION FAULT	203→Motor Acceleration Fault — Average Load Current [VALUE].	Check that inlet guide vanes are fully closed at start-up. Check Motor Rated Load Amps in VFD_CONF screen. Reduce unit pressure if possible.
204	FAILURE TO STOP	VFD SHUTDOWN FAULT	204→VFD Shutdown Fault: Check Inverter Power Unit.	VFD Circuit Board malfunction. Contact Carrier Service.
205	PROTECTIVE LIMIT	HIGH DC BUS VOLTAGE	205→High DC Bus Voltage: [VALUE] exceeded limit of [LIMIT]*.	Verify phase to phase and phase to ground line voltage. Monitor AC line for high transient voltage conditions. VFD Circuit Board malfunction. Contact Carrier Service.
206	PROTECTIVE LIMIT	VFD FAULT	206→VFD Fault Code: [VALUE]; Check VFD Fault Code List.	See VFD Fault Code description and corrective action.
207	PROTECTIVE LIMIT	HIGH CONDENSER PRESSURE	207→High Cond Pressure trip. [VALUE] exceeded Switch Trippoint.	Check Compressor Discharge High Pressure switch wiring and accuracy. Check for high condenser water temperatures, low water flow, fouled tubes. Check for division plate/gasket bypass. Check for noncondensables in refrigerant.
208	PROTECTIVE LIMIT	EXCESSIVE MOTOR AMPS	208→Percent Load Current [VALUE] exceeded limit of [LIMIT]*.	Check Motor Rated Load Amps in VFD_CONF screen. Percent Load Current > 110%. Check Motor Rated Load Amps setting.
209	PROTECTIVE LIMIT	LINE CURRENT IMBALANCE	209→Line Current Imbalance: Check VFD Fault History for Values.	Check phase to phase and phase to ground power distribution bus voltage. Check Line Current % Imbalance in VFD_CONF screen. Consult power company.
210	PROTECTIVE LIMIT	LINE VOLTAGE DROPOUT	210→Single Cycle Line Voltage Dropout.	Temporary loss of voltage. Disable Single Cycle Dropout in VFD_CONF screen.
211	PROTECTIVE LIMIT	HIGH LINE VOLTAGE	211→High Percent Line Voltage [VALUE].	Check phase to phase and phase to ground distribution bus voltage. Consult power company.
212	PROTECTIVE LIMIT	LOW LINE VOLTAGE	212→Low Percent Line Voltage [VALUE].	Check phase to phase and phase to ground distribution bus voltage. Consult power company.
213	PROTECTIVE LIMIT	VFD MODULE RESET	213→VFD Module Power-On Reset When Running.	Temporary loss of VFD control voltage. Check VFD control power breaker, transformer and fuses.
214	PROTECTIVE LIMIT	POWER LOSS	214→Control Power Loss When Running.	Check phase to phase and phase to ground distribution bus voltage. Check VFD fuses. Check 24 vac power supply to ICVC. Consult power company.
215	PROTECTIVE LIMIT	LOW DC BUS VOLTAGE	215→Low DC Bus Voltage: [VALUE] exceeded limit of [LIMIT]*.	Verify phase-to-phase and phase-to-ground line voltage. VFD Circuit Board malfunction. Contact Carrier Service.
216	PROTECTIVE LIMIT	LINE VOLTAGE IMBALANCE	216→Line Voltage Imbalance. Check VFD Fault History for Values.	Check phase-to-phase and phase-to-ground distribution bus voltage. Increase Line Voltage % Imbalance in VFD_CONF screen.
217	PROTECTIVE LIMIT	MOTOR OVERLOAD TRIP	217→Motor Overload Trip; Check VFD configurations.	Any phase current > 106% Rated Load Amps. Can result from significant load side current imbalance when running at full load. Check entering condenser water temperature and water flow rate. Check Motor Rated Load Amps in VFD_CONF screen.
218	PROTECTIVE LIMIT	VFD RECTIFIER OVERTEMP	218→VFD Rectifier Temp Exceeded: Check Cooling and VFD Config.	Check that VFD refrigerant isolation valves are open. Check VFD refrigerant cooling solenoid and refrigerant strainer. Check for proper VFD cooling fan operation and blockage.
219	PROTECTIVE LIMIT	VFD INVERTER OVERTEMP	219→VFD Inverter Temp Exceeded: Check Cooling and VFD Config.	Check that VFD refrigerant isolation valves are open. Check VFD refrigerant cooling solenoid and refrigerant strainer. Check for proper VFD cooling fan operation and blockage.

*[LIMIT] is shown on the ICVC as the temperature, pressure, voltage, etc., set point predefined or selected by the operator as an override, alert, or alarm condition. [VALUE] is the actual pressure, temperature, voltage, etc., at which the control tripped.
 NOTE: ICVC Alarms 212-226 are declared as a result of VFD Faults.

Table 5 — ICVC Alarm Codes (cont)

CHILLER PROTECTIVE LIMIT FAULTS (cont)

ICVC FAULT STATE	PRIMARY MESSAGE	SECONDARY MESSAGE	PRIMARY CAUSE	ADDITIONAL CAUSE/REMEDY
220	PROTECTIVE LIMIT	GROUND FAULT	220→Ground Fault Trip; Check Motor and Current Sensors.	Check for condensation on motor terminals. Check motor power leads for phase to phase or phase to ground shorts. Disconnect motor from VFD and megger motor. Contact Carrier Service.
221	PROTECTIVE LIMIT	UNUSED	221→UNUSED	
222	PROTECTIVE LIMIT	LINE FREQUENCY TRIP	222→Line Frequency — [VALUE] exceeded limit of [LIMIT]; Check Power Supply.	If operating from a generator, check generator size and speed. Check utility power supply.
223	LOSS OF COMMUNICATION	WITH VFD GATEWAY MODULE	223→Loss of SIO Comm with VFD Gateway: Check VFG Module and Power.	Check VFD communication wiring and connectors on VFD Gateway and DPI board. Check for compatibility between ICVC and Gateway software.
224	PROTECTIVE LIMIT	VFD COMMUNICATIONS FAULT	224→Loss of DPI Comm with VFD Gateway: Check VFG to VFD Comm.	Check VFD communication wiring and connectors. Check status lights on DPI Communications Interface Board. Contact Carrier Service.
225	PROTECTIVE LIMIT	MOTOR CURRENT IMBALANCE	225→Motor Current Imbalance: Check VFD Fault History for Values.	Check Motor Current % Imbalance in VFD_CONF screen.
226	PROTECTIVE LIMIT	LINE PHASE REVERSAL	226→Line Phase Reversal: Check Line Phases.	Reverse connections of any two line conductors to circuit breaker.
227	PROTECTIVE LIMIT	OIL PRESS SENSOR FAULT	227→Oil Pressure Delta P [VALUE] (Pump Off): Check Pump/Transducers.	Check transducer wiring and accuracy. Check power supply to pump. Check pump operation. Check transducer calibration.
228	PROTECTIVE LIMIT	LOW OIL PRESSURE	228→Low Operating Oil Pressure [VALUE]: Check Oil Pump and Filter.	Check transducer wiring and accuracy. Check power supply to pump. Check pump operation. Check oil level. Check for partially closed service valves. Check oil filters. Check for foaming oil at start-up. Check transducer calibration.
229	PROTECTIVE LIMIT	LOW CHILLED WATER FLOW	229→Low Chilled Water Flow; Check Switch/Delta P Config & Calibration.	Perform pump control test. Check optional transducer calibration and wiring. Check Evaporator Refrigerant Temperature sensor. Check chilled water valves. Check for evaporator saturation temperature < 34 F if not in Pumpdown Lockout mode. Place unit in Pumpdown mode before removing charge.
230	PROTECTIVE LIMIT	LOW CONDENSER WATER FLOW	230→Low Condenser Water Flow; Check Switch/Delta P Config & Calibration.	Perform pump control test. Check optional transducer calibration and wiring. Check condenser water valves. Check for COND PRESS OVERRIDE + 5 psig.
231	PROTECTIVE LIMIT	HIGH DISCHARGE TEMP	231→Comp Discharge Temp [VALUE] Exceeded Limit of [LIMIT]*.	Check for closed compressor discharge isolation valve. Check if chiller was operating in surge. Check sensor resistance or voltage drop. Check for proper wiring. Check for proper condenser flow and temperature. Check compressor discharge isolation valve. Check for proper inlet guide vane and optional diffuser actuator operation.
232	PROTECTIVE LIMIT	LOW REFRIGERANT TEMP	232→Evaporator Refrig Temp [VALUE] exceeded limit of [LIMIT]*.	Check for proper refrigerant charge. Check float valve operation. Check for closed condenser liquid line isolation valve. If problem occurs at high load, check for low condenser pressure which causes inadequate flasc orifice differential pressure. Check for proper water flow and temperature. Confirm that condenser water enters bottom row of condenser tubes first. Check Evaporator Refrigerant Temperature sensor. Check for division plate gasket bypass. Check for fouled tubes.

*[LIMIT] is shown on the ICVC as the temperature, pressure, voltage, etc., set point predefined or selected by the operator as an override, alert, or alarm condition. [VALUE] is the actual pressure, temperature, voltage, etc., at which the control tripped.

Table 5 — ICVC Alarm Codes (cont)

CHILLER PROTECTIVE LIMIT FAULTS (cont)

ICVC FAULT STATE	PRIMARY MESSAGE	SECONDARY MESSAGE	PRIMARY CAUSE	ADDITIONAL CAUSE/REMEDY
233	PROTECTIVE LIMIT	HIGH MOTOR TEMPERATURE	233→Comp Motor Winding Temp [VALUE] exceeded limit of [LIMIT]*.	Check motor sensors wiring and accuracy. Check motor cooling line and spray nozzle for proper operation, or restrictions. Check for excessive starts within a short time span.
234	PROTECTIVE LIMIT	HIGH BEARING TEMPERATURE	234→Comp Thrust Brg Temp [VALUE] exceeded limit of [LIMIT]*.	Check oil heater for proper operation. Check for low oil level, partially closed oil supply valves, or clogged oil filter. Check oil cooler refrigerant thermal expansion valves. Confirm that TXV (thermostatic expansion valve) bulb is secured in place and insulated. Check for sensor wiring and accuracy. This fault can result from extended operation at low load with low water flow to the evaporator or condenser.
235	PROTECTIVE LIMIT	HIGH CONDENSER PRESSURE	235→Condenser Pressure [VALUE] exceeded limit of [LIMIT]*.	Check for high condenser water temperatures, low water flow, fouled tubes. Check for division plate/gasket bypass. Check for noncondensables. Check transducer wiring and accuracy.
236	PROTECTIVE LIMIT	COMPRESS SURGE/ LOW SPEED	236→Compressor Surge: Check condenser water temp and flow.	Check for high condenser water temperatures, low water flow, fouled tubes. Check for division plate/gasket bypass. Check for noncondensables. Check surge prevention parameters in OPTIONS screen. Increase VFD Increase Step in SETUP2. Check VFD Minimum Speed in SETUP2 screen.
237	PROTECTIVE LIMIT	SPARE SAFETY DEVICE	237→Spare Safety Device.	Spare safety input has tripped or factory installed jumper is not present on Terminal Block 4 terminals 17 and 20 in the VFD enclosure.
238	PROTECTIVE LIMIT	EXCESSIVE COMPR SURGE	238→Compressor Surge: Check condenser water temp and flow.	Check for high condenser water temperatures, low water flow, fouled tubes. Check for division plate/gasket bypass. Check for noncondensables. Check surge prevention parameters in OPTIONS screen. Check cooling tower control settings and performance to design/selection temperatures across the entire operating range of the chiller. Check cooler approach and water flow.
239	PROTECTIVE LIMIT	TRANSDUCER VOLTAGE FAULT	239→Transducer Voltage Ref [VALUE] exceeded limit of [LIMIT]*.	Check that CCM transducer voltage reference is between 4.5 v and 5.5 v. Check that pressure transducers are not shorted to ground. This fault is normally declared the first time an ICVC is powered up if it was downloaded with software when it was not connected to a CCM. Contact Carrier Service.
240	PROTECTIVE LIMIT	LOW DISCHARGE SUPERHEAT	240→Check for Oil in Or Overcharge of Refrigerant.	Check for oil loss or excessive refrigerant. If oil level is low, refrigerant charge may be too low resulting in ineffective oil reclaim. Excessive refrigerant charge may cause liquid carryover into compressor. Check calibration of evaporator pressure and condenser pressure sensors. Check calibration of compressor discharge temperature sensor.
241	PROTECTIVE LIMIT	RECTIFIER OVERCURRENT	241→Rectifier Overcurrent Fault: Check VFD Status.	Check for high water temperatures or changes in water flow rates.
242	LOSS OF COMMUNICATION	WITH CCM MODULE	242→Loss of Communication With CCM, Check Comm. Connectors.	Check wiring and control power to CCM. Confirm that all CCM SW1 switches are in the "OFF" position.
243	POTENTIAL FREEZE-UP	EVAP PRESS/TEMP TOO LOW	243→Evaporator Refrig Temp [VALUE] exceeded limit of [LIMIT]*.	Check for proper refrigerant charge. Check float valve operation. Check for proper fluid flow and temperature. Confirm that condenser water enters bottom row of condenser tubes first. Check Evaporator Refrigerant Temperature sensor. Check for division plate gasket bypass. Check for fouled tubes.
244	POTENTIAL FREEZE-UP	COND PRESS/TEMP TOO LOW	244→Condenser Refrig Temp [VALUE] exceeded limit of [LIMIT]*.	Condenser water too cold or chiller shut down with brine below 32 F in cooler so equalization temperature in chiller approached 32 F. Check condenser pressure transducer. Check refrigerant charge.

*[LIMIT] is shown on the ICVC as the temperature, pressure, voltage, etc., set point predefined or selected by the operator as an override, alert, or alarm condition. [VALUE] is the actual pressure, temperature, voltage, etc., at which the control tripped.

Table 5 — ICVC Alarm Codes (cont)

CHILLER PROTECTIVE LIMIT FAULTS (cont)

ICVC FAULT STATE	PRIMARY MESSAGE	SECONDARY MESSAGE	PRIMARY CAUSE	ADDITIONAL CAUSE/REMEDY
245	PROTECTIVE LIMIT	HIGH VFD SPEED	245→Actual VFD Speed exceeded limit of Target VFD Speed + 10%.	Actual VFD Speed on COMPRESS screen must not exceed Target VFD Speed by more than 10%.
246	PROTECTIVE LIMIT	INVALID DIFFUSER CONFIG.	246→Diffuser Control Invalid Configuration: Check SETUP2 Entries.	Check 25%, 50%, and 75% Guide Vane and Diffuser Load Point entries in SETUP2 screen.
247	PROTECTIVE LIMIT	DIFFUSER POSITION FAULT	247→Diffuser Position Fault: Check Guide Vane/Diffuser Actuator.	Confirm that Diffuser Option in SETUP 2 screen has not been Enabled if compressor does not have a split ring diffuser. May indicate rotating stall condition. Check rotating stall transducer wiring accuracy and sealing. Check diffuser schedule and guide vane schedule in SETUP2 screen. Check for proper operation of diffuser and inlet guide vane actuators including inlet guide vane calibration. Check diffuser actuator coupling for rotational slip. Check RC snubber on CCM J4-23 and J4-24. Check 4.3k ohm resistor between CCM terminals J3-7 and J3-8. Check for electrical noise in CCM Diffuser Pressure wiring. Do not continue to operate compressor except for diagnostic purposes.
248	PROTECTIVE LIMIT	SPARE TEMPERATURE #1	248→Spare Temperature #1 [VALUE] exceeded limit of [LIMIT]*.	Check Spare Temperature Enable and Spare Temperature Limit in SETUP1 Screen.
249	PROTECTIVE LIMIT	SPARE TEMPERATURE #2	249→Spare Temperature #2 [VALUE] exceeded limit of [LIMIT]*.	Check Spare Temperature Enable and Spare Temperature Limit in SETUP1 Screen.
250	UNUSED	UNUSED	250→Unused State.	
251	PROTECTIVE LIMIT	VFD CONFIG CONFLICT	251→VFD Config Conflict (VFD Uploaded): Verify to Reset Alarm.	The VFD_CONF table in the Gateway does not match that which is in the ICVC. This is a normal fault if an ICVC has been uploaded with software when it was not attached to the CCM. Enter VFD_CONF screen and then exit VFD_CONF screen by pressing EXIT then CANCEL. Re-enter the VFD_CONF screen, press EXIT then SAVE. Parameters stored in the Gateway will be uploaded into the ICVC. Confirm valid settings in VFD_CONF screen.
252	PROTECTIVE LIMIT	VFD CONFIG CONFLICT	252→VFD Config Conflict (VFD Downloaded): Verify to Reset Alarm.	The VFD_CONF table in the Gateway does not match that which is in the ICVC.
253	PROTECTIVE LIMIT	GUIDE VANE CALIBRATION	253→Guide Vane Fault [VALUE]. Check Calibration.	Enter CONTROL TEST and execute Guide Vane Calibration. Check CCM guide vane feedback terminals J4-9 and J4-10. Check guide vane feedback potentiometer. Alarm before start indicates guide vane opening is not less than 4%. Alarm running indicates guide vane position is < -1% or > 103%, or feedback voltage is < .045 or > 3.15 VDC.
254	PROTECTIVE LIMIT	VFD CHECKSUM ERROR	254→Checksum Error: Press Reset to Restore Configuration.	Actual VFD checksum does not match calculated value.
255	PROTECTIVE LIMIT	VFD DEW PREVENTION	255→Dew Prevention - Coolant Too Cold. Check Solenoid & Cond T.	VFD COLDPLATE TEMP is too close to dew point based on VFD ENCLOSURE TEMP and RELATIVE HUMIDITY in POWER screen. Check for moisture in VFD enclosure. Check Humidity Sensor in CONTROLS TEST. Check for contamination on CCM J3-7 and J3-9 Humidity Sensor. Check that VFD refrigerant cooling modulating valve is closing.
256	PROTECTIVE LIMIT	INDUCTOR OVERTEMP	256→Inductor Overtemp Trip - Check Temp Switch and Cooling Fans.	Check for cooling fan air flow obstructions.
257	PROTECTIVE LIMIT	VFD START INHIBIT	257→VFD Start Inhibit: Check VFD Diagnostic Parameters 212/214.	The VFD Start Inhibit is derived from the Alarm bit being set in the VFD. The conditions causing the alarm must be corrected in the VFD to enable subsequent starts and operation. See VFD parameters 212/214.
258	UNUSED STATE	UNUSED	258→Unused.	

*[LIMIT] is shown on the ICVC as the temperature, pressure, voltage, etc., set point predefined or selected by the operator as an override, alert, or alarm condition. [VALUE] is the actual pressure, temperature, voltage, etc., at which the control tripped.

Table 5 — ICVC Alarm Codes (cont)

CHILLER PROTECTIVE LIMIT FAULTS (cont)

ICVC FAULT STATE	PRIMARY MESSAGE	SECONDARY MESSAGE	PRIMARY CAUSE	ADDITIONAL CAUSE/REMEDY
259	PROTECTIVE LIMIT	CCN OVERRIDE STOP	259→CCN Emergency/Override Stop.	CCN has signaled the chiller to stop.This fault must be manually reset from the default screen of the ICVC.
282	PROTECTIVE LIMIT	INVALID VFD CONFIG	282→Line Frequency [VALUE] Exceeded Configuration Range.	LINE FREQUENCY in POWER screen must be maintained between 45-52 Hz if LINE FREQ=60Hz? is set to NO(50 Hz). LINE FREQUENCY must be maintained between 55-62 Hz if LINE FREQ=60Hz? is set to YES (60 Hz). Check high pressure switch and connections to TB4-24 and TB4-25.
283	PROTECTIVE LIMIT	INVALID VFD CONFIG	283→Compressor 100% Speed Config Ranges: 50=Hz 45-52; 60 Hz=55-62.	COMPRESSOR 100% SPEED in VFD_CONF screen must be set between 45-52 Hz if LINE FREQ=60Hz? is set to NO(50 Hz). COMPRESSOR 100% SPEED must be set between 55-62 Hz if LINE FREQ=60Hz? is set to YES (60 Hz).
284	VFD GATEWAY	COMPATIBILITY CONFLICT	284→VFD Gateway Compatibility Conflict: Check VFG/VFD Versions.	VFD Gateway and VFD software versions are not compatible. Contact Carrier Service.
285	VFD GATEWAY	COMPATIBILITY CONFLICT	285→VFD Gateway Compatibility Conflict: Check VFG/ICVC Versions.	VFD Gateway and ICVC software versions are not compatible. Contact Carrier Service.
286	PROTECTIVE LIMIT	INVERTER OVERCURRENT	286→Inverter Overcurrent Fault: Check VFD Status.	Check for high entering water temperature or low condenser water flow. Check current settings in VFD_CONF screen.

*[LIMIT] is shown on the ICVC as the temperature, pressure, voltage, etc., set point predefined or selected by the operator as an override, alert, or alarm condition. [VALUE] is the actual pressure, temperature, voltage, etc., at which the control tripped.

OUT-OF-RANGE SENSOR

ICVC FAULT STATE	PRIMARY MESSAGE	SECONDARY MESSAGE	PRIMARY CAUSE	ADDITIONAL CAUSE/REMEDY
260	SENSOR FAULT	LEAVING CHILLED WATER	260→Sensor Fault: Check Leaving Chilled Water Sensor.	Check sensor resistance or voltage drop. Check for proper wiring. Check for disconnected or shorted wiring.
261	SENSOR FAULT	ENTERING CHILLED WATER	261→Sensor Fault: Check Entering Chilled Water Sensor.	Check sensor resistance or voltage drop. Check for proper wiring. Check for disconnected or shorted wiring.
262	SENSOR FAULT	CONDENSER PRESSURE	262→Sensor Fault: Check Condenser Pressure Sensor.	Check sensor wiring. Check for disconnected or shorted wiring. Check for condensation in transducer connector.
263	SENSOR FAULT	EVAPORATOR PRESSURE	263→Sensor Fault: Check Evaporator Pressure Sensor.	Check sensor wiring. Check for disconnected or shorted wiring. Check for condensation in transducer connector.
264	SENSOR FAULT	COMPRESSOR BEARING TEMP	264→Sensor Fault: Check Comp Thrust Brg Temp Sensor.	Check sensor resistance or voltage drop. Check for proper wiring. Check for disconnected or shorted wiring.
265	SENSOR FAULT	COMPRESSOR MOTOR TEMP	265→Sensor Fault: Check Comp Motor Winding Temp Sensor.	Check sensor resistance or voltage drop. Check for proper wiring. Check for disconnected or shorted wiring.
266	SENSOR FAULT	COMP DISCHARGE TEMP	266→Sensor Fault: Check Comp Discharge Temp Sensor.	Check sensor resistance or voltage drop. Check for proper wiring. Check for disconnected or shorted wiring.
267	SENSOR FAULT	OIL SUMP TEMP	267→Sensor Fault: Check Oil Sump Temp Sensor.	Check sensor resistance or voltage drop. Check for proper wiring. Check for disconnected or shorted wiring.
268	SENSOR FAULT	COMP OIL PRESS DIFF	268→Sensor Fault: Check Oil Pump Delta P Sensor.	Check sensor resistance or voltage drop. Check for proper wiring. Check for disconnected or shorted wiring.
269	SENSOR FAULT	CHILLED WATER FLOW	269→Sensor Fault: Check Chilled Water Delta P Sensor.	Check sensor wiring and accuracy. Check for disconnected or shorted wiring. If pressure transducers are not installed, check for presence of resistors and jumpers on lower CCM terminal block J3.
270	SENSOR FAULT	COND WATER FLOW	270→Sensor Fault: Check Cond Water Delta P Sensor.	Check sensor wiring and accuracy. Check for disconnected or shorted wiring. If pressure transducers are not installed, check for presence of resistors and jumpers on lower CCM terminal block J3.
271	SENSOR FAULT	EVAP SATURATION TEMP	271→Sensor Fault: Check Evap Saturation Temp Sensor.	Check sensor resistance or voltage drop. Check for proper wiring. Check for disconnected or shorted wiring.

Table 6 — Powerflex 755 Fault Code Descriptions and Corrective Actions

VFD FAULT CODE ON VFD HIST SCREEN	ICVC FAULT STATE	FAULT TYPE	DESCRIPTION	CORRECTIVE ACTION
NONE	206		Processor memory fault	Consult VFD manual to resolve generic fault.
0		No Entry		
2	207	Auxiliary Input	Input is open.	Check Compressor Discharge High Pressure switch wiring and accuracy. Check for high condenser water temperatures, low water flow, fouled tubes. Check for division plate/gasket bypass. Check for noncondensables in refrigerant.
3	210	Power Loss	Line voltage dropout	Temporary loss of voltage. Disable Single Cycle Dropout in VFD_CONF screen.
4	215	Undervoltage	Low DC bus voltage	Verify phase-to-phase and phase-to-ground line voltage. VFD Circuit Board malfunction. Contact Carrier Service.
5	166	Overvoltage	High DC bus voltage	Verify phase to phase and phase to ground line voltage. Monitor AC line for high transient voltage conditions.
7	217	Motor Overload	An internal electronic overload trip has occurred.	Any phase current > 106% RLA. Can result from significant load side current imbalance when running at full load. Check entering condenser water temperature and water flow rate. Check Motor Rated Load Amps in VFD_CONF screen.
8	219	Heat Sink Over-temp	Heat sink temperature has exceeded maximum operating temperature.	Check that VFD refrigerant isolation valves are open. Check VFD refrigerant cooling orifice and refrigerant strainer. Check for proper VFD cooling fan operation and air flow blockage.
9	219	Transistor Over-temp	The output transistors have exceeded maximum operating temperature.	Check that VFD refrigerant isolation valves are open. Check VFD refrigerant cooling orifice and refrigerant strainer. Check for proper VFD cooling fan operation and air flow blockage.
12	286	HW Overcurrent	The drive output current has exceeded hardware current limit.	Check for high entering water temperature or low condenser water flow. Check current settings in VFD_CONF screen.
13	220	Ground Fault	A current path to earth ground greater than 25% of drive rating has occurred.	Check the motor, motor terminals, and external wiring to the drive output terminals for a grounded condition.
14	206	Ground Warning	The ground current has exceeded the level set in P467.	—
15	206	Load Loss	If this fault appears, there may be a problem with software configuration.	To reset the processor, cycle power to chiller, check ICVC VFD_CONF settings and save settings when exiting VFD_CONF screen. Check VFD parameters with Drive Explorer.
17	216	The DC bus ripple has exceeded a preset level.	Line Voltage imbalance	Check phase-to-phase and phase-to-ground distribution bus voltage. Increase Line Voltage % Imbalance in VFD_CONF screen.
20	206	TorqPrv Spd Band	See VFD Fault Code 15	See VFD Fault Code 15
21	225	Output PhaseLoss	The current in one or more phases has been lost or remains below a preset level.	Check Motor Current % Imbalance in VFD_CONF screen.
24	204	Decel Inhibit	The drive is not following a commanded deceleration because it is attempting to limit bus voltage.	Verify input voltage is within drive specified limits. Verify system ground impedance follows proper grounding techniques. Disable bus regulation P186 and/or add dynamic brake resistor and/or extend deceleration time P537 and P538.
33	206	AuRsts Exhausted	See VFD Fault Code 15	See VFD Fault Code 15
36	286	SW Overcurrent	The drive output current has exceeded the 1 ms current rating.	Check for excess load, improper DC boost setting, DC brake volts set too high.

Table 6 — Powerflex 755 Fault Code Descriptions and Corrective Actions (cont)

VFD FAULT CODE ON VFD HIST SCREEN	ICVC FAULT STATE	FAULT TYPE	DESCRIPTION	CORRECTIVE ACTION
38	220	Phase U to Gnd	GROUND FAULT	Check wiring between drive and motor. Check motor for grounded phase. Check motor terminals. Replace drive.
39		Phase V to Gnd		
40		Phase W to Gnd		
41	246	Phase UV Short	GROUND FAULT	Check wiring between drive and motor. Check motor terminals. Replace drive.
42		Phase VW Short		
43		Phase WU Short		
44	206	Phase UNot	GROUND FAULT (no LF2 equivalent)	Check wiring between drive and motor. Check motor terminals. Replace drive.
45	206	Phase VNot ToGnd		
46	206	Phase WNot		
55	NONE	Inverter Overtemp	The temperature sensor on the main control board detected excessive heat.	Check that VFD refrigerant isolation valves are open. Check VFD refrigerant strainer.
61	206	Shear Pin 1	See VFD Fault Code 15	See VFD Fault Code 15
62	206	Shear Pin 2	See VFD Fault Code 15	See VFD Fault Code 15
64	206	Drive Overload	Drive is overloaded.	Check for high entering water temperature or low condenser water flow. Check current settings in VFD_CONF screen.
65	206	OW TrqLvlTimeout	See VFD Fault Code 15	See VFD Fault Code 15
77	206	IR Volts Range	See VFD Fault Code 15	See VFD Fault Code 15
78	206	FluxAmpsRef Rang	See VFD Fault Code 15	See VFD Fault Code 15
79	206	Excessive Load	Motor did not come up to speed in the allotted time.	Check that guide vanes are closed completely. Check for high entering water temperature or low condenser flow. Repeat Autotune
80	206	AutoTune Aborted	See VFD Fault Code 15	See VFD Fault Code 15
87	206	IXo VoltageRange	Ixo voltage calculated from motor nameplate data is too high.	Re-enter motor nameplate data in VFD_CONF screen.
91	206	Pri VelFdbk Loss	See VFD Fault Code 15	See VFD Fault Code 15
93	206	HW Enable Check	See VFD Fault Code 15	See VFD Fault Code 15
94	206	Alt VelFdbk Loss	See VFD Fault Code 15	See VFD Fault Code 15
95	206	Aux VelFdbk Loss	See VFD Fault Code 15	See VFD Fault Code 15
96	206	PositionFdbkLoss	See VFD Fault Code 15	See VFD Fault Code 15
97	206	Auto Tach Switch	See VFD Fault Code 15	See VFD Fault Code 15
100	206	Parameter Chksum	The checksum read from the board does not match the checksum calculated.	Press ICVC reset. Check VFD_CONF parameters. Cycle power to the drive.
107	NONE	Replaced MCB-PB	The main control board was moved to a different power structure. Data set to default values.	Press ICVC reset. Check VFD_CONF parameters. Cycle power to the drive.
113	206	Tracking DataErr	Internal data error	Press ICVC reset. Cycle power to the drive.
124	206	App ID Changed	Application firmware changed.	Verify application version.
141	206	Autn Enc Angle	P78 [EncdrLss AngComp] is out of range.	See VFD Fault Code 15
142	206	Autn Spd Rstrct	See VFD Fault Code 15	See VFD Fault Code 15
143	206	Autotune CurReg	See VFD Fault Code 15	See VFD Fault Code 15
144	206	Autotune Inertia	See VFD Fault Code 15	See VFD Fault Code 15
145	206	Autotune Travel	See VFD Fault Code 15	See VFD Fault Code 15

Table 6 — Powerflex 755 Fault Code Descriptions and Corrective Actions (cont)

VFD FAULT CODE ON VFD HIST SCREEN	ICVC FAULT STATE	FAULT TYPE	DESCRIPTION	CORRECTIVE ACTION
168	206	HeatSinkUnder-Tmp	Heatsink temperature sensor is reporting a value below -18.7 C (-1.66 F) or the sensor feedback circuit is open.	Check heat sink temperature sensor. Check heat sink temperature.
210	206	HW En Jumper Out	See VFD Fault Code 15	See VFD Fault Code 15
211	206	Safety Brd Fault	See VFD Fault Code 15	See VFD Fault Code 15
213	206	Safety Jumper In	See VFD Fault Code 15	See VFD Fault Code 15
291	206	HSFan Lifwe	See VFD Fault Code 15	See VFD Fault Code 15
292	206	InFan Life	See VFD Fault Code 15	See VFD Fault Code 15
293	206	MtrBrG Life	See VFD Fault Code 15	See VFD Fault Code 15
294	206	MtrBrG Lube	See VFD Fault Code 15	See VFD Fault Code 15
295	206	MachBrG life	See VFD Fault Code 15	See VFD Fault Code 15
296	206	MachBrG Lube	See VFD Fault Code 15	See VFD Fault Code 15
315	206	Excess Psn Error	See VFD Fault Code 15	See VFD Fault Code 15
316	206	Node Fault Error	See VFD Fault Code 15	See VFD Fault Code 15

Checking Power Modules and Motor Input with Input Power Off — Use the following procedure to check the drive’s power module circuitry with power off:

1. Turn off and lock out input power. Wait five minutes.
2. Verify there is no voltage at the drive’s input power terminals.
3. Using a voltmeter, check the DC bus potential as described above to ensure the DC bus capacitors are discharged.
4. Disconnect the motor from the drive.
5. Check all AC line and DC bus fuses.
6. Use a multimeter to check the input diodes and output IGBTs if a fuse is open.
7. Check motor impedance.
8. Reconnect the motor to the drive.
9. Reapply input power. See Table 7.

⚠ WARNING
Confirm that the DC bus has discharged before performing diode checks.

Table 7 — Diode Checks

	METER LEAD		METER READING
	(+)	(-)	
R		DC+	0.5 V
		DC-	infinite (OL)
S		DC+	0.5 V
		DC-	Infinite (OL)
T		DC+	0.5 V
		DC-	Infinite (OL)
U		DC+	0.5 V
		DC-	infinite (OL)
V		DC+	0.5 V
		DC-	Infinite (OL)
W		DC+	0.5 V
		DC-	Infinite (OL)
DC+		R	Infinite (OL)
		S	
		T	
		U	
		V	
		W	
DC-		R	0.5 V
		S	
		T	
		U	
		V	
		W	

NOTE: Digital meters require a special diode check function because the current sourced by the meter during a normal resistance (Ohms) test is too low to accurately test a diode. Make sure the meter is set to the diode test function. Voltage readings may not be exact as shown in above tables, but look for consistency during each of the 4 tests. When performing a test that should return infinity (OL) as shown in above tables, you may see a value slowly climbing toward infinity. This is a result of the meter charging a capacitor and is normal.

Servicing the Drive

⚠ WARNING

To guard against possible personal injury and/or equipment damage:

1. Inspect all lifting hardware for proper attachment before lifting drive.
2. Do not allow any part of the drive or lifting mechanism to make contact with electrically charged conductors or components.
3. Do not subject the drive to high rates of acceleration or deceleration while transporting to the mounting location or when lifting.

Do not allow personnel or their limbs directly underneath the drive when it is being lifted and mounted.

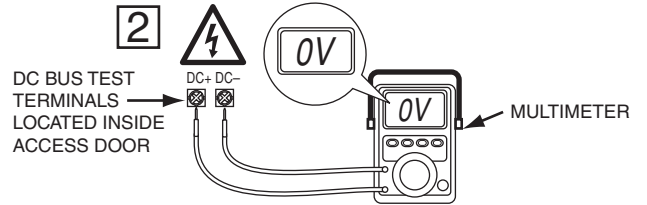
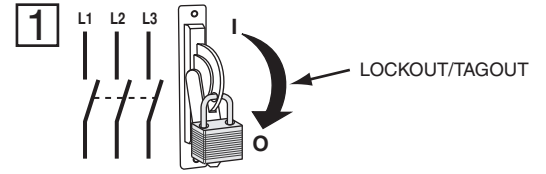

Fig. 18 — Check DC Bus Terminals

⚠ WARNING

DC bus capacitors retain hazardous voltages after input power has been disconnected. After disconnecting input power, wait five (5) minutes for the DC bus capacitors to discharge and then check the voltage with a voltmeter to ensure the DC bus capacitors are discharged before touching any internal components. Failure to observe this precaution could result in severe bodily injury or loss of life.

1. Using recommended screwdriver = 6.4 mm (0.25 in.) flat or T20 star, open access door. See Fig. 17.
2. Check to be sure that the voltage between DC+ and DC- and from each DC terminal to the chassis is zero before proceeding. See Fig. 18.
3. Remove the enclosure. See Fig. 19.

REMOVING THE DRIVE — The dimensions and weights specified must be taken into consideration when removing the drive. All lifting equipment and lifting components (hooks, bolts, lifts, slings, chains, etc.) must be properly sized and rated to safely lift and hold the weight of the drive while removing it. For 19XRV chillers, see Fig. 20. For 23XRV chillers, see Fig. 21. The drive weights are as follows:

- Drive weight for Frame 6: 85 lb.
- Drive weight for Frame 7: 160 - 249 lb.

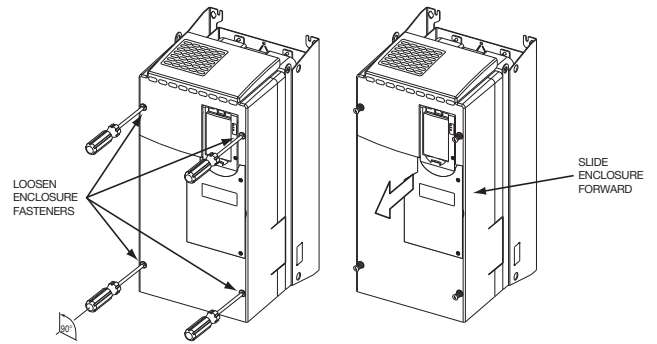

Fig. 19 — Removing Enclosure

When replacing the drive, reverse the procedures and tighten to the torques for the Frames 6 and 7 Power Terminal Block referred to in Table 8.

Table 8 — Frames 6 and 7 Power Terminal Block

FRAME	MAXIMUM LUG WIDTH	RECOMMENDED TORQUE	TERMINAL BOLT SIZE
6	34.6 mm (1.36 in.)	11.3 N·m (100 in.-lb)	M8 x 1.25
7	43.5 mm (1.71 in.)	11.3 N·m (100 in.-lb)	M8 x 1.25

RIGGING THE ENCLOSURE — Where overhead room and/or clearance in front of the drive enclosure is insufficient to allow the drive to be safely removed from the enclosure, the entire enclosure may have to be removed from the chiller.

The dimensions and weights specified must be taken into consideration when removing the enclosure. For 19XRV chillers, the total weight for Frames 6 and 7, including drive weight and enclosure, is 720 lb. The 23XRV chiller enclosure, including all components, weighs 975 lb. All lifting equipment and lifting components (hooks, bolts, lifts, slings, chains, etc.) must be properly sized and rated to safely lift and hold the weight of the enclosure and drive while removing. See Fig. 22A and Fig. 22B.

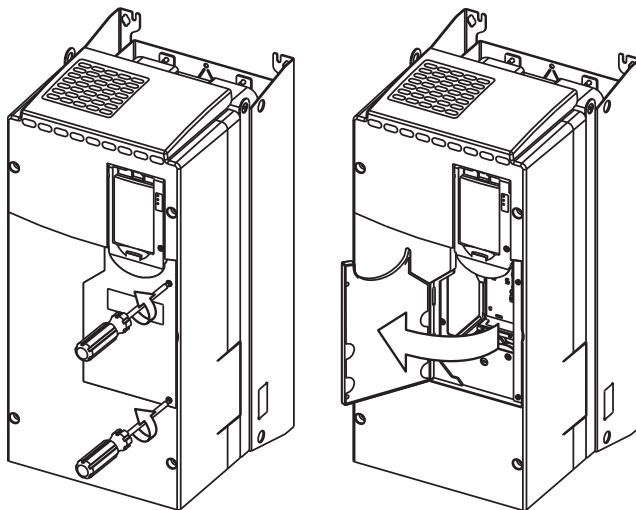

Fig. 17 — Open Access Door

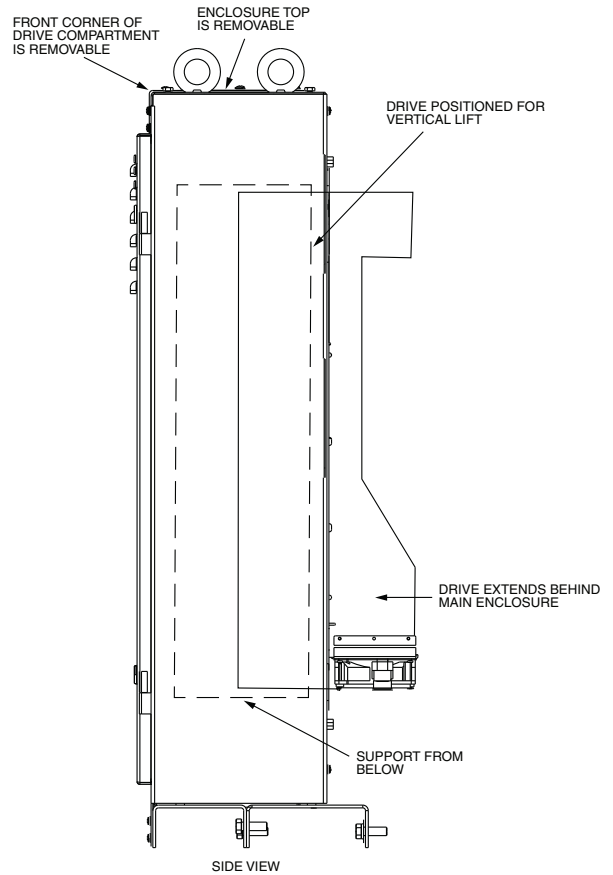
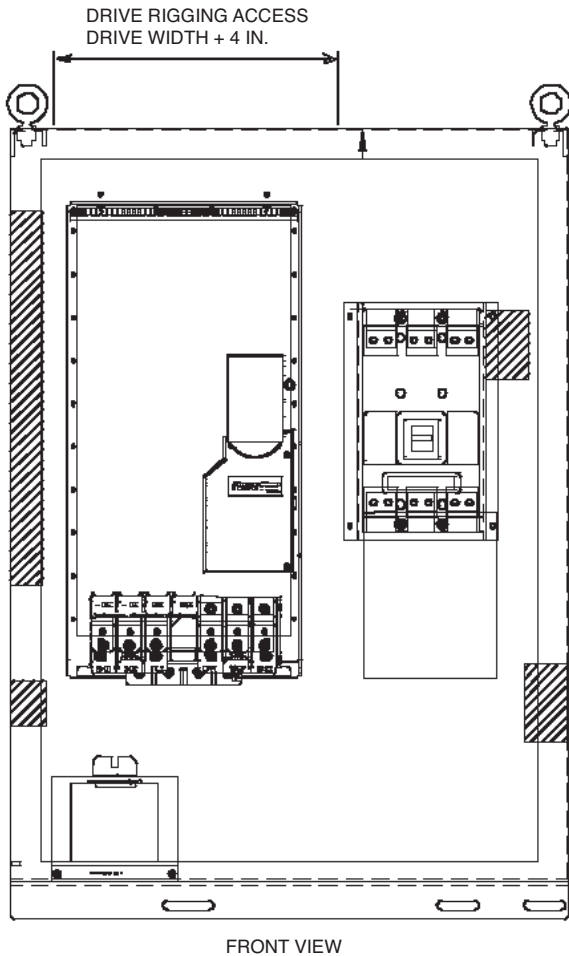

Fig. 21 — 23XRV Enclosure Access for Removing Drive

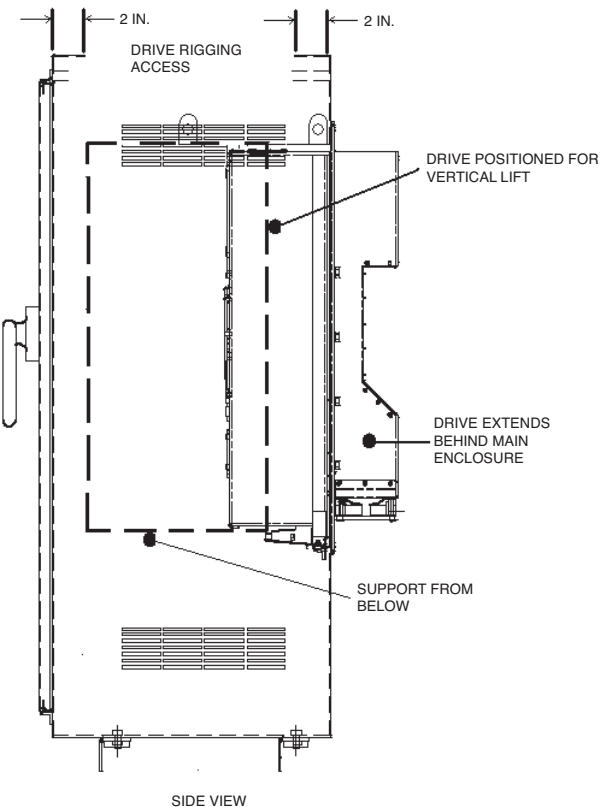

Fig. 20 — 19XRV Enclosure Access for Removing Drive

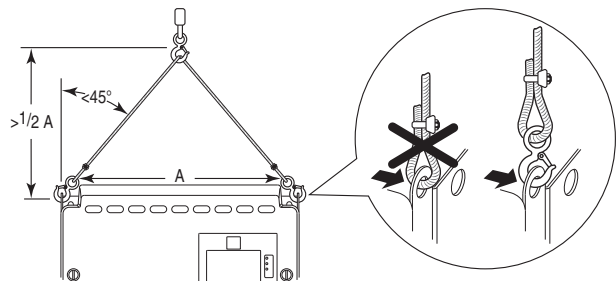

Fig. 22A — Rigging the Enclosure, Frame 6

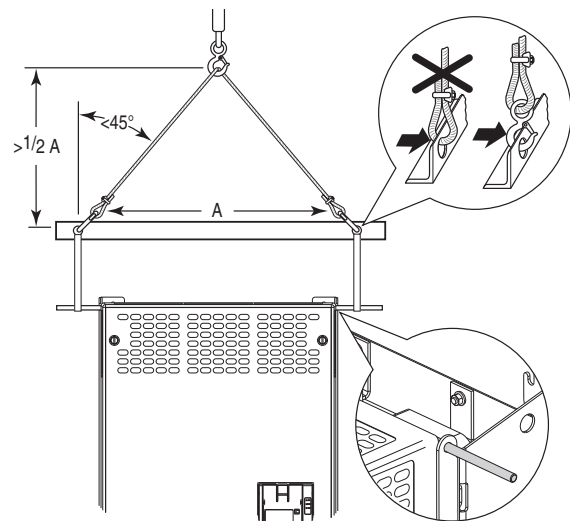

Fig. 22B — Rigging the Enclosure, Frame 7

REPLACING THE GATEWAY (A-B20-750-20COMM OPTION CARD) — The following are the steps for removing and replacing the existing gateway.

1. Disconnect power to the drive. Before removing the enclosure, open the access door on the front of the drive. See Fig. 17.
2. Check to be sure that the voltage between DC+ and DC- and from each DC terminal to the chassis is zero before proceeding. See Fig. 18.
3. Remove the enclosure. See Fig. 19.
4. Remove the 2 screws securing the mounting plate and remove the mounting plate and COMM card. See Fig. 23.
5. Mount the new COMM card and mounting plate and attach with the 2 screws removed in Step 4. See Fig. 24.
6. Use the shorter ribbon cable to connect the plug on the COMM card to the connector on the mounting plate. See Fig. 23.
7. Install the enclosure. See Fig. 19.

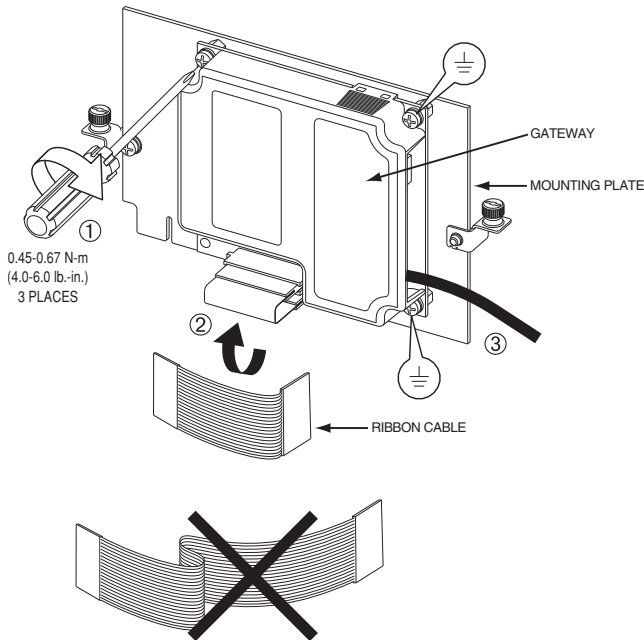

Fig. 23 — COMM Card

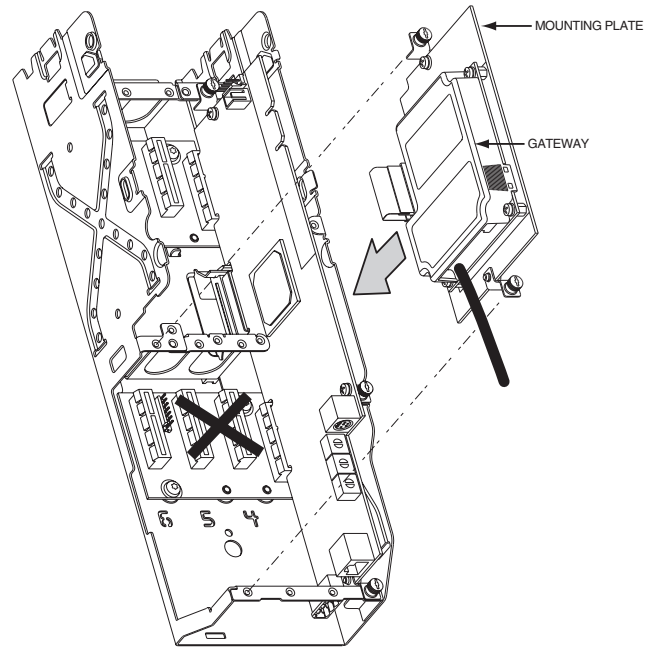

Fig. 24 — Mount COMM Card Plate to Drive

CHILL PLATE FAN AND INTERNAL FAN REPLACEMENT — The following are the steps to replace the chill plate fan and internal fan in Frames 6 and 7.

Frame 6:

1. Disconnect power to the drive. Before removing the enclosure, open the access door on the front of the drive. See Fig. 17.
2. Check to be sure that the voltage between DC+ and DC- and from each DC terminal to the chassis is zero before proceeding. See Fig. 18.
3. Remove the enclosure. See Fig. 19.
4. Remove and replace the chill plate fan. See Fig. 25.
5. Remove and replace the internal fan. See Fig. 26.
6. Install the enclosure. See Fig. 19.

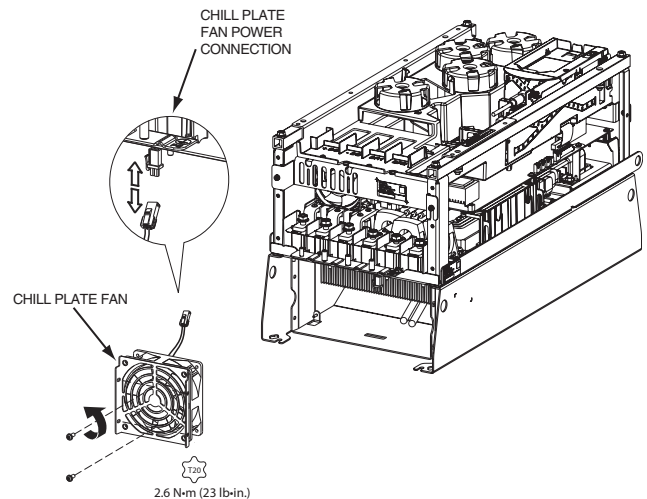

Fig. 25 — Chill Plate Fan, Frame 6

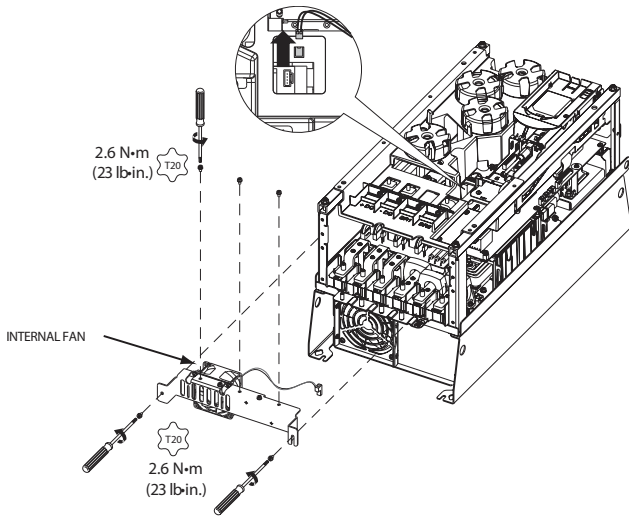

Fig. 26 — Internal Fan, Frame 6

Frame 7:

1. Disconnect power to the drive. Before removing the enclosure, open the access door on the front of the drive. See Fig. 17.
2. Check to be sure that the voltage between DC+ and DC- and from each DC terminal to the chassis is zero before proceeding. See Fig. 18.
3. Remove the enclosure. See Fig. 19.

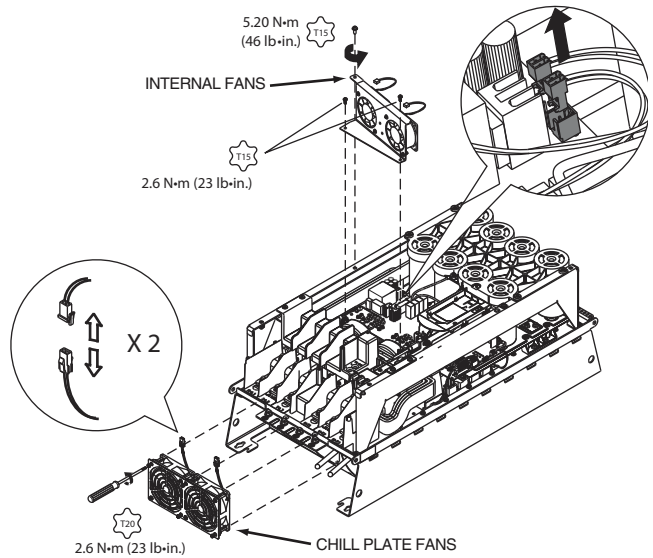

Fig. 27 — Chill Plate and Internal Fans, Removal and Replacement, Frame 7

Part Identification and Location — See Fig. 28-31 for parts descriptions and locations.

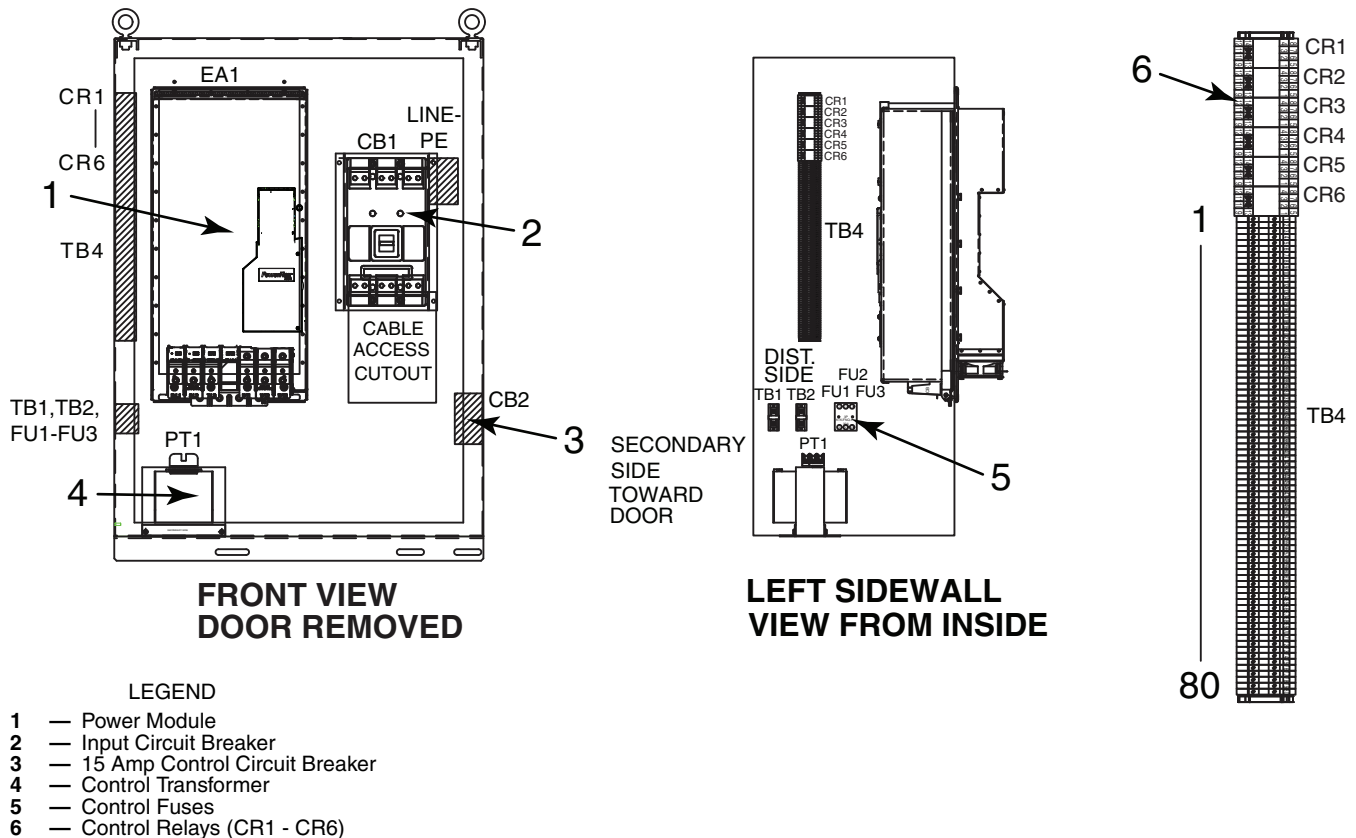
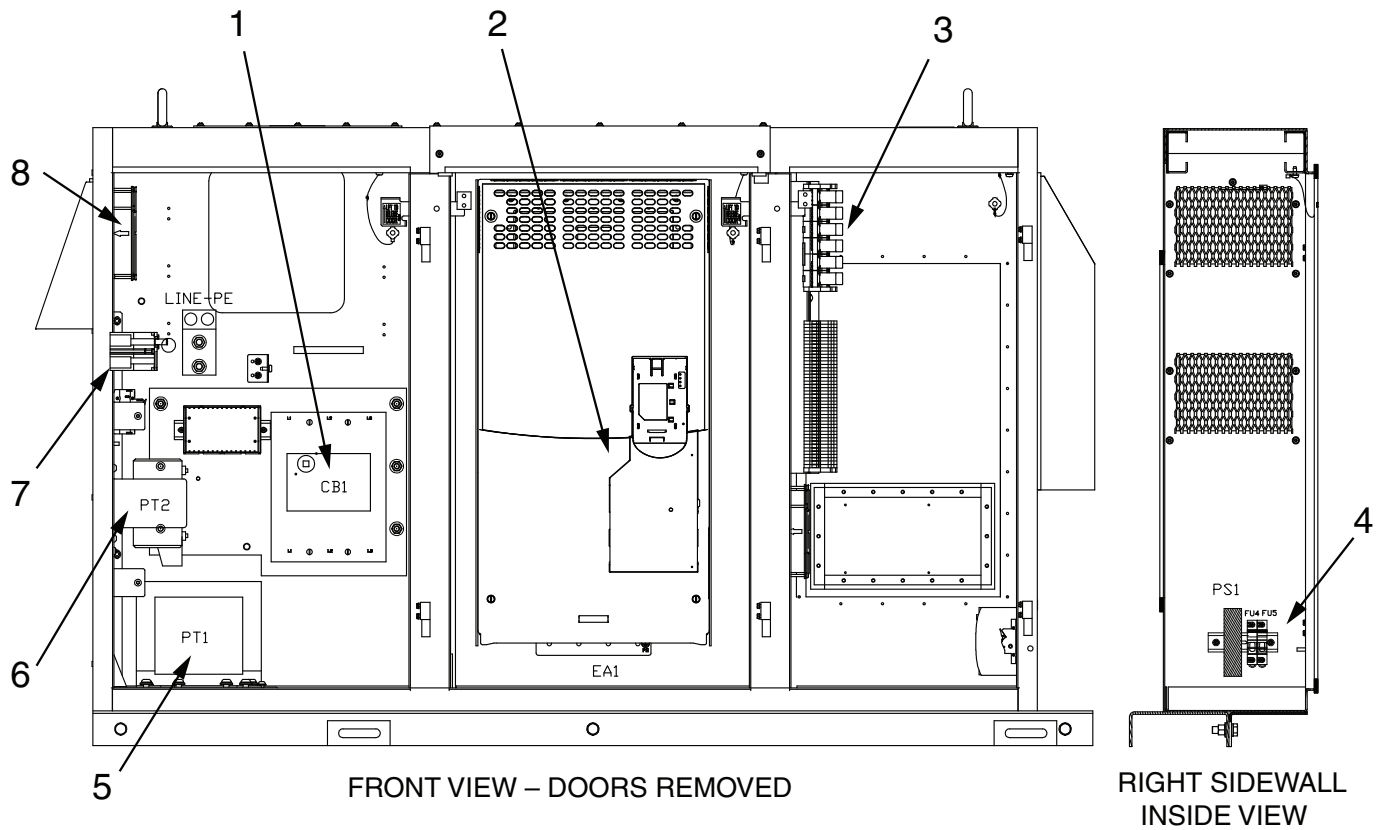
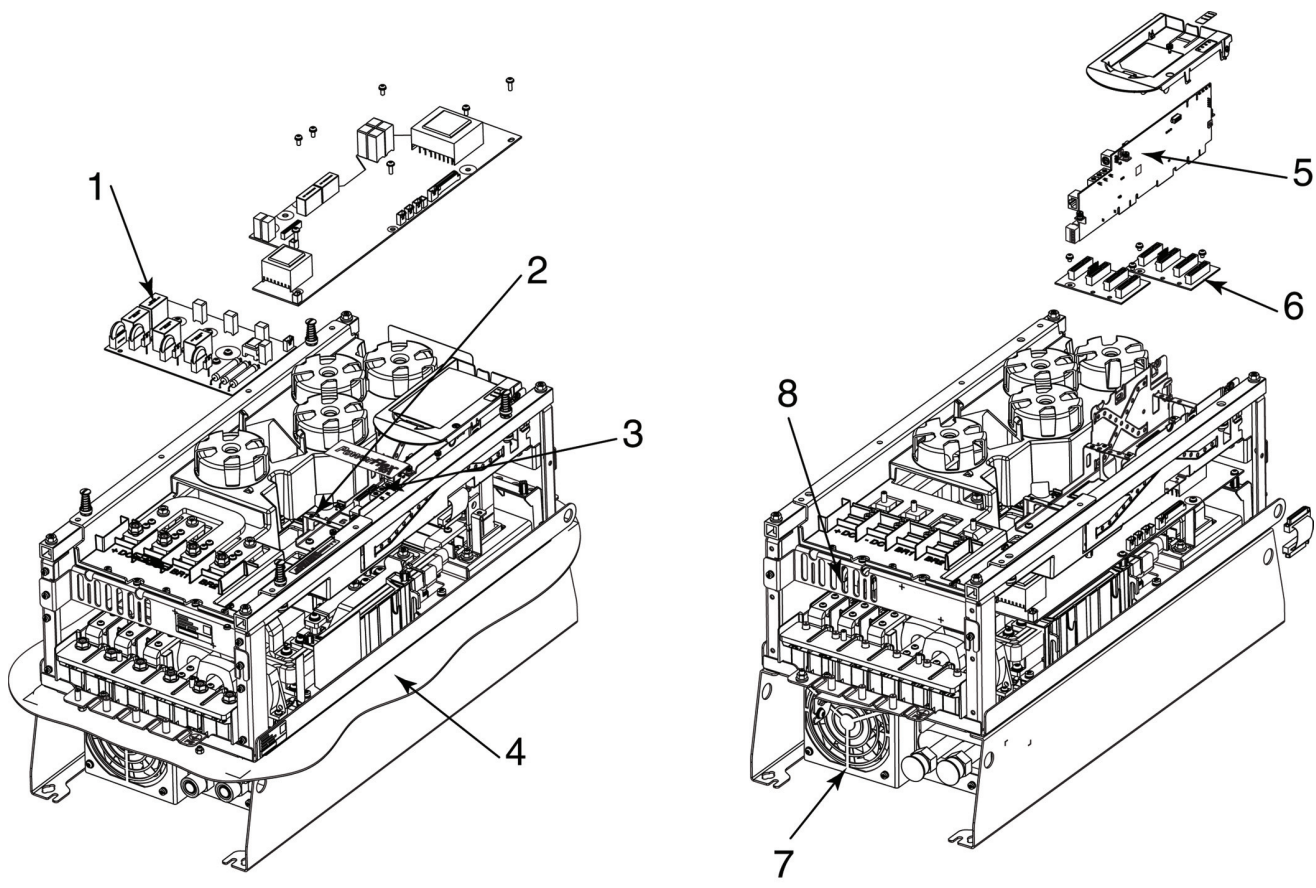

Fig. 28 — 19XRV Assembly Parts



- LEGEND
- 1 — Input Circuit Breaker
 - 2 — Power Module
 - 3 — Control Relays (CR1 - CR6)
 - 4 — Control Fans
 - 5 — 120V Control Transformer
 - 6 — 120V Vaporizer Heater Transformer
 - 7 — 15 Amp Control Circuit Breaker
 - 8 — Cooling Fan

Fig. 29 — 23XRV Assembly Parts



NOTE: When replacing the Main Control Board (Item No. 1) the jumper marked "J1 ENABLE" must be removed and the jumper marked "J1 SAFETY" must be left in place.

LEGEND

- 1 — PF750 Series, Precharge Kit
- 2 — PF750 Series, Gate Interface
- 3 — PF750 Series, Power Interface
- 4 — PowerFlex 750 Series, Flange Gasket
- 5 — PF755 Main Control Board
- 6 — PF750 Series, Backplane Interface
- 7 — PF750 Series, Type 4X/12 Chill Plate (Heatsink) Fan Kit
- 8 — Chill Plate Fan

Fig. 30 — Frame 6 Parts

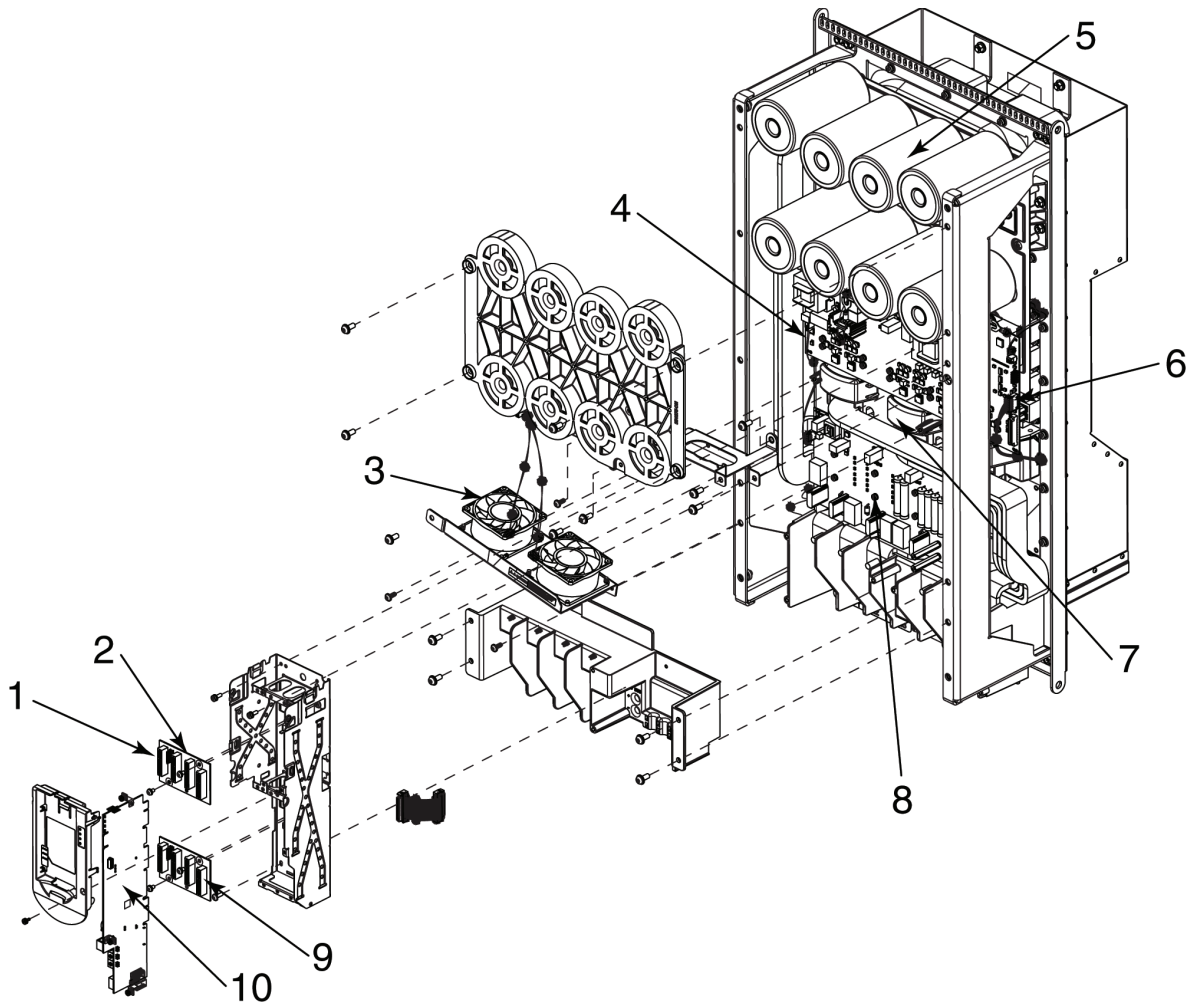

LEGEND

- 1 — Slot for Gateway (Gateway Not Shown)
- 2 — PF750 Series, Backplane Interface
- 3 — PF750 Series, Type 4X/12 Heatsink Fan Kit
- 4 — PF750 Series, Power Interface
- 5 — PF750 Series, Bus Cap Assembly
- 6 — PF750 Series, Power Interface Cable
- 7 — PF750 Series, Current Transducer Kit
- 8 — PF750 Series, Precharge Kit
- 9 — Slot for 24V I/O Module (24V I/O Module Not Shown)
- 10 — PF755 Main Control Board

NOTE: When replacing the Main Control Board (Item No. 1) the jumper marked "J1 ENABLE" must be removed and the jumper marked "J1 SAFETY" must be left in place.

Fig. 31 — Frame 7 Parts

APPENDIX A — WIRING SCHEMATICS

CHILLER CONTROL SCHEMATIC

CONTINUED ON
FACING PAGE

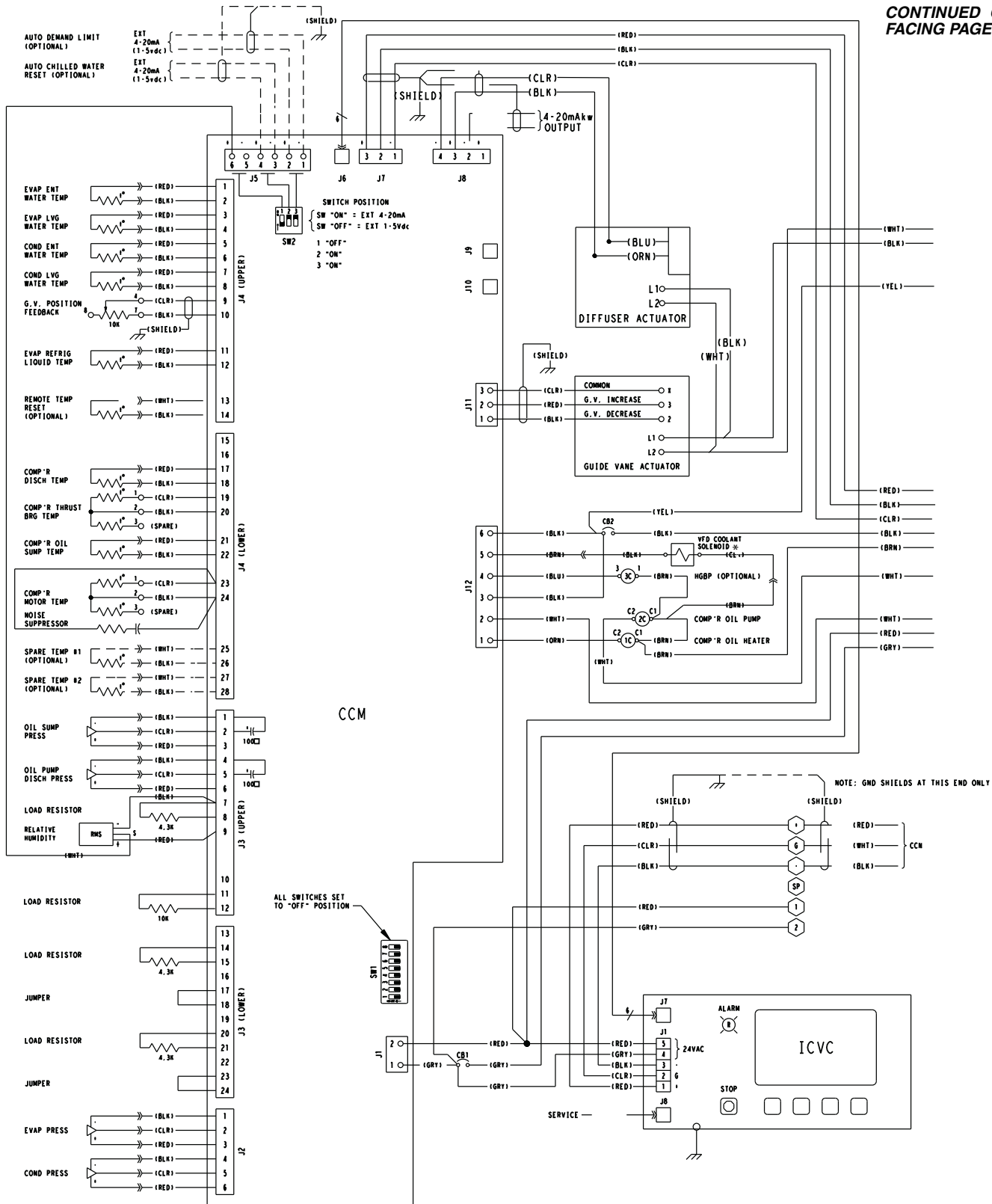

APPENDIX A — WIRING SCHEMATICS (cont)

CHILLER CONTROL SCHEMATIC (cont)

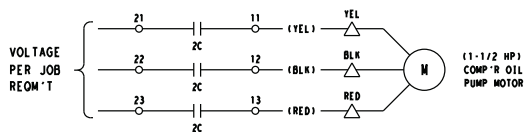
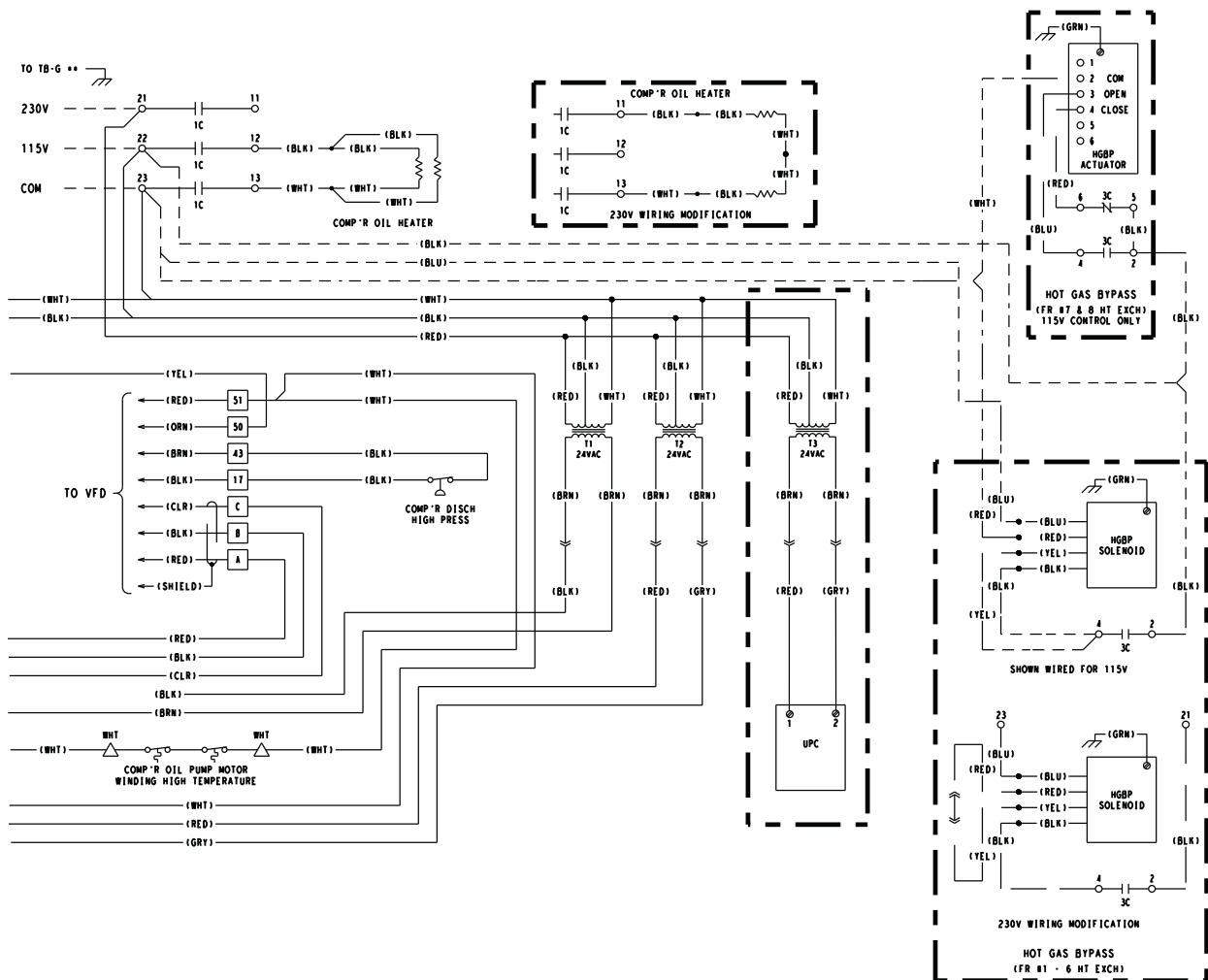

LEGEND

- CB** Circuit Breaker
- CCM** Chiller Control Module
- HGBP** Hot Gas Bypass
- ICVC** International Chiller Visual Controller
- RHS** Relative Humidity Sensor
- UPC** Universal Protocol Controller
- VFD** Variable Frequency Drive

- Denotes Control Panel Terminal
- Denotes Oil Pump Terminal
- Denotes Power Panel Terminal
- **** Denotes Motor Starter Panel Conn
- Denotes Component Terminal
- Wire Splice
- Denotes Conductor Male/Female Connector
- Option Wiring

* Standard on LF2 drive; optional on machines equipped with other VFDs.

APPENDIX A — WIRING SCHEMATICS (cont)

ROCKWELL POWERFLEX 755 WIRING SCHEMATIC (Typical)

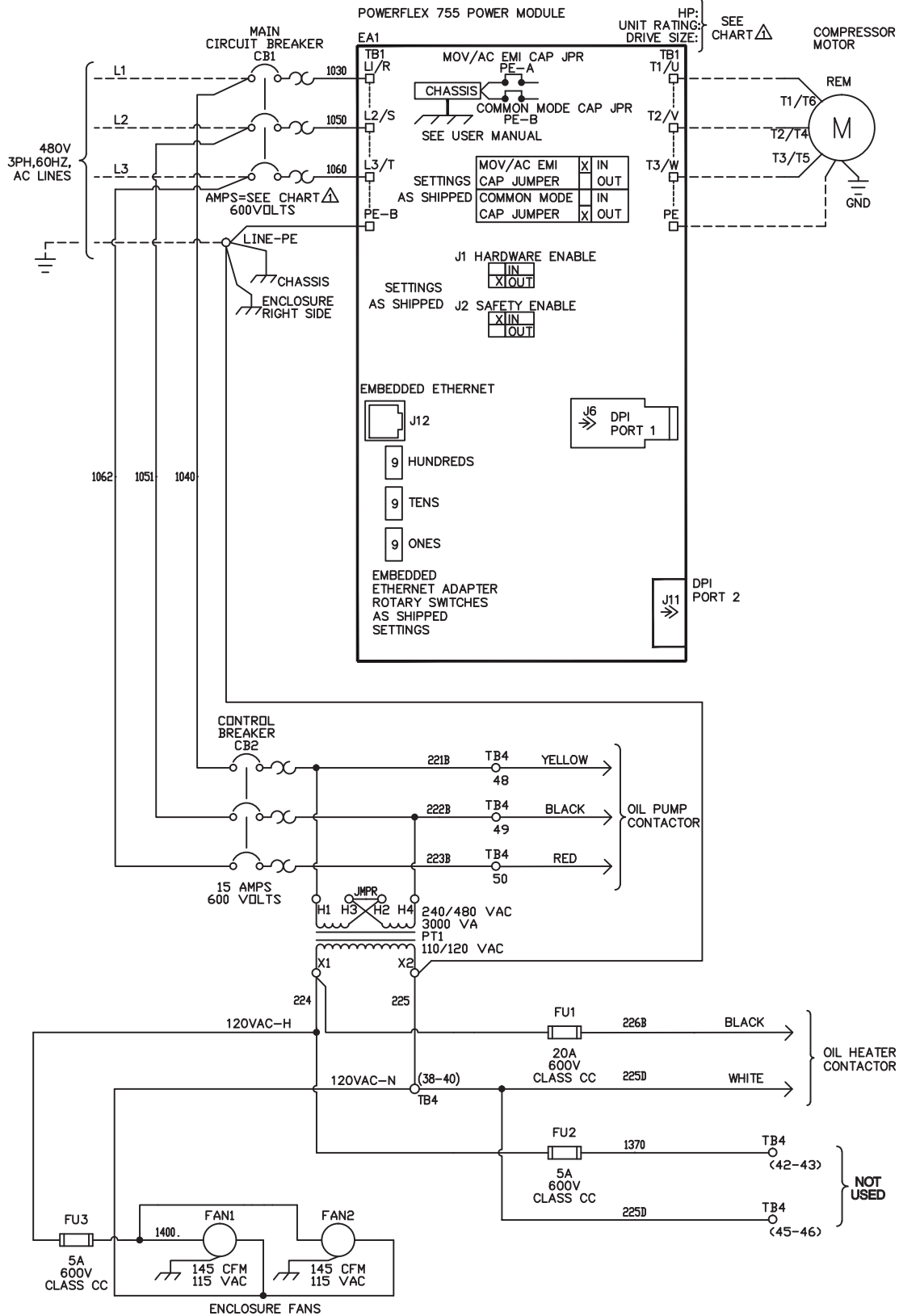

APPENDIX A — WIRING SCHEMATICS (cont)

ROCKWELL POWERFLEX 755 WIRING SCHEMATIC (Typical) (cont)

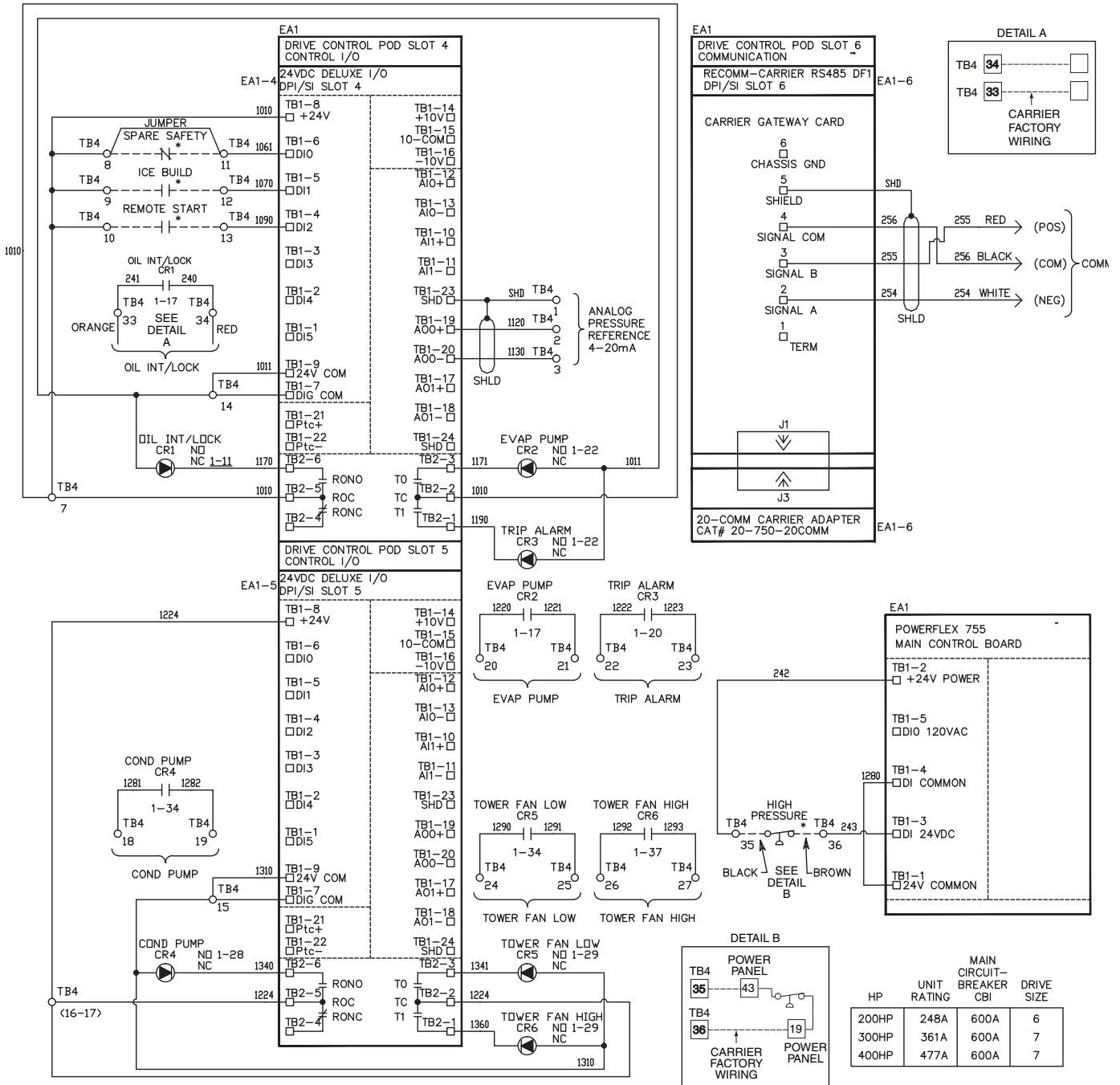

LEGEND

CAP	—	Capacitor
CB	—	Circuit Breaker
COM	—	Common
COMM	—	Communication
COND	—	Condenser
CR	—	Control Relay
DPI/SI	—	Internal Communication Protocols Connections
EA	—	Electrical Assembly
EMI	—	Electro-Magnetic Interference
EVAP	—	Evaporator
FU	—	Fuse
GND	—	Ground
JMPR	—	Jumper
M	—	Motor
NC	—	Normally Closed
NO	—	Normally Open
PE	—	Potential Earth (Ground)
POD	—	I/O Card Mounting Slot Board
REM	—	Remote
ROC	—	Relay Output Common
SHLD	—	Shield
TB	—	Terminal Block

* Located outside of starter; connected by field wiring.

APPENDIX B — OPTIONAL BACNET COMMUNICATIONS WIRING

Optional BACnet* Communications Wiring —

The following section is used to configure the UPC Open controller which is used when the BACnet communications option is selected. The UPC Open controller is mounted in a separate enclosure below the main control box.

TO ADDRESS THE UPC OPEN CONTROLLER — The user must give the UPC Open controller an address that is unique on the BACnet network. Perform the following procedure to assign an address:

1. If the UPC Open controller is powered, pull the screw terminal connector from the controller's power terminals labeled Gnd and HOT. The controller reads the address each time power is applied to it.
2. Using the rotary switches (see Fig. A and B), set the controller's address. Set the Tens (10's) switch to the tens digit of the address, and set the Ones (1's) switch to the ones digit.

As an example in Fig. B, if the controller's address is 25, point the arrow on the Tens (10's) switch to 2 and the arrow on the Ones (1's) switch to 5.

NOTE: The UPC Open Controller should not be polled by the Building Management System (BMS) at a rate greater than 2 polls/min. Also, the UPC Open Controller should not poll the chiller at a rate greater than 2 polls/min. If the poll rate is within the acceptable range of 2 polls/min and a response problem occurs, contact Carrier Service.

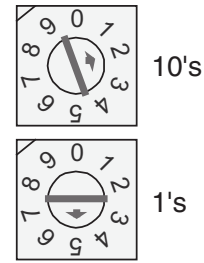

Fig. B — Address Rotary Switches

BACNET DEVICE INSTANCE ADDRESS — The UPC Open controller also has a BACnet Device Instance address. This Device Instance **MUST** be unique for the complete BACnet system in which the UPC Open controller is installed. The Device Instance is auto generated by default and is derived by adding the MAC address to the end of the Network Number. The Network Number of a new UPC Open controller is 16101, but it can be changed using i-Vu® Tools or BACView device. By default, a MAC address of 20 will result in a Device Instance of 16101 + 20 which would be a Device Instance of 1610120.

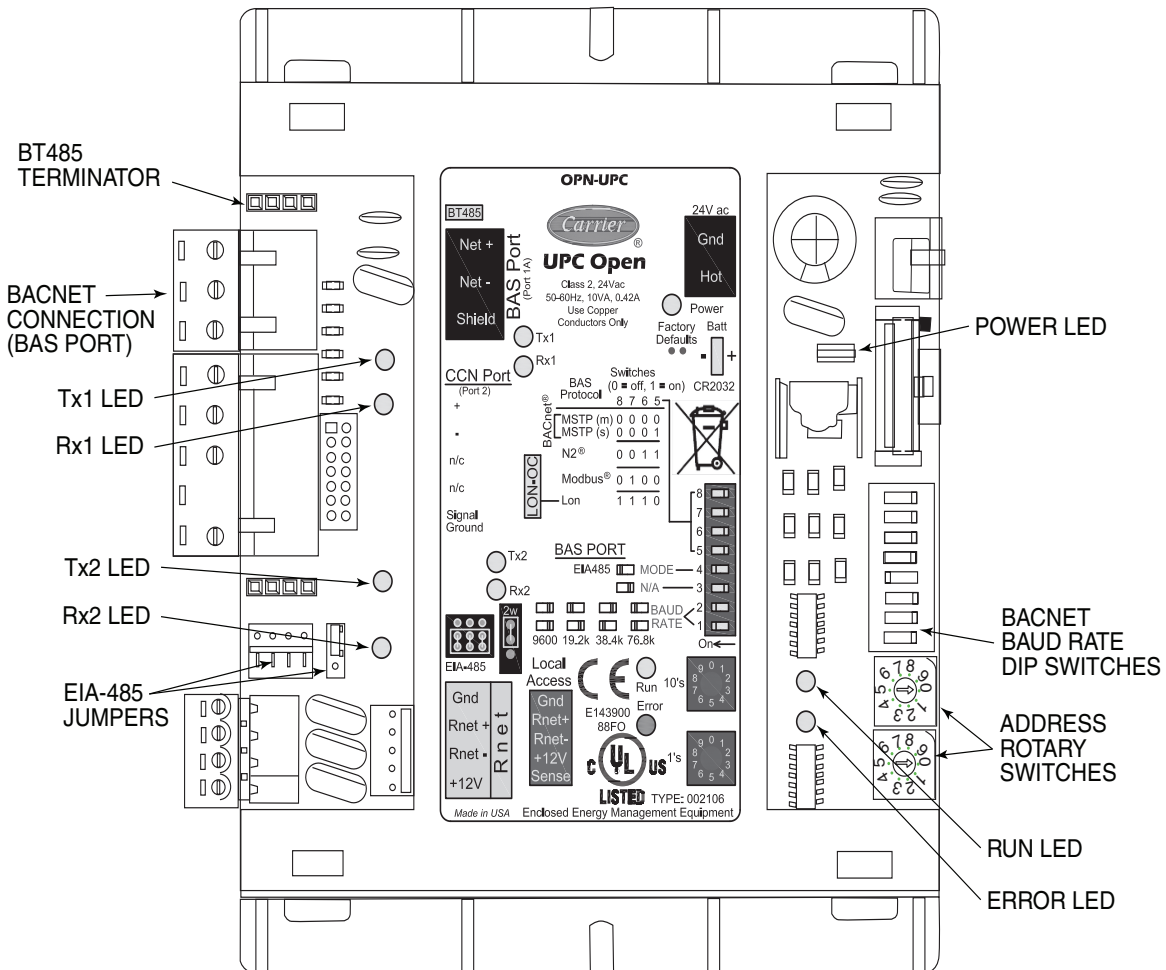

Fig. A — UPC Open Controller

* Sponsored by ASHRAE (American Society of Heating, Refrigerating and Air Conditioning Engineers).

APPENDIX B — OPTIONAL BACNET COMMUNICATIONS WIRING (cont)

CONFIGURING THE BAS PORT FOR BACNET MS/TP — Use the same baud rate and communication settings for all controllers on the network segment. The UPC Open controller is fixed at 8 data bits, No Parity, and 1 Stop bit for this protocol's communications.

If the UPC Open controller has been wired for power, pull the screw terminal connector from the controller's power terminals labeled Gnd and HOT. The controller reads the DIP Switches and jumpers each time power is applied to it.

Set the BAS Port DIP switch DS3 to “enable.” Set the BAS Port DIP switch DS4 to “EIA-485.” Set the BMS Protocol DIP switches DS8 through DS5 to “MSTP.” See Table A.

Table A — SW3 Protocol Switch Settings for MS/TP

DS8	DS7	DS6	DS5	DS4	DS3
Off	Off	Off	Off	On	Off

Verify that the EIA-485 jumpers below the CCN Port are set to EIA-485 and 2W.

The example in Fig. C shows the BAS Port DIP Switches set for 76.8k (Carrier default) and MS/TP.

Set the BAS Port DIP Switches DS2 and DS1 for the appropriate communications speed of the MS/TP network (9600, 19.2k, 38.4k, or 76.8k bps). See Fig. C and Table B.

Table B — Baud Selection Table

BAUD RATE	DS2	DS1
9,600	Off	Off
19,200	On	Off
38,400	Off	On
76,800	On	On

WIRING THE UPC OPEN CONTROLLER TO THE MS/TP NETWORK — The UPC Open controller communicates using BACnet on an MS/TP network segment communications at 9600 bps, 19.2 kbps, 38.4 kbps, or 76.8 kbps.

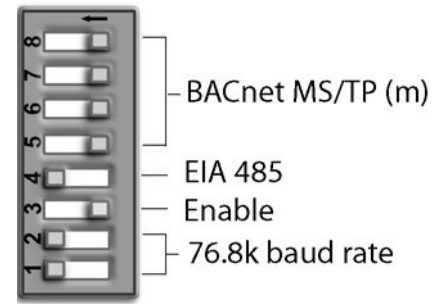

Fig. C — DIP Switches

Wire the controllers on an MS/TP network segment in a daisy-chain configuration. Wire specifications for the cable are 22 AWG (American Wire Gage) or 24 AWG, low-capacitance, twisted, stranded, shielded copper wire. The maximum length is 2000 ft.

Install a BT485 terminator on the first and last controller on a network segment to add bias and prevent signal distortions due to echoing. See Fig. B, D, and E.

To wire the UPC Open controller to the BAS network:

1. Pull the screw terminal connector from the controller's BAS Port.
2. Check the communications wiring for shorts and grounds.
3. Connect the communications wiring to the BAS port's screw terminals labeled Net +, Net -, and Shield.

NOTE: Use the same polarity throughout the network segment.

4. Insert the power screw terminal connector into the UPC Open controller's power terminals if they are not currently connected.
5. Verify communication with the network by viewing a module status report. To perform a module status report using the BACview keypad/display unit, press and hold the “FN” key then press the “.” Key.

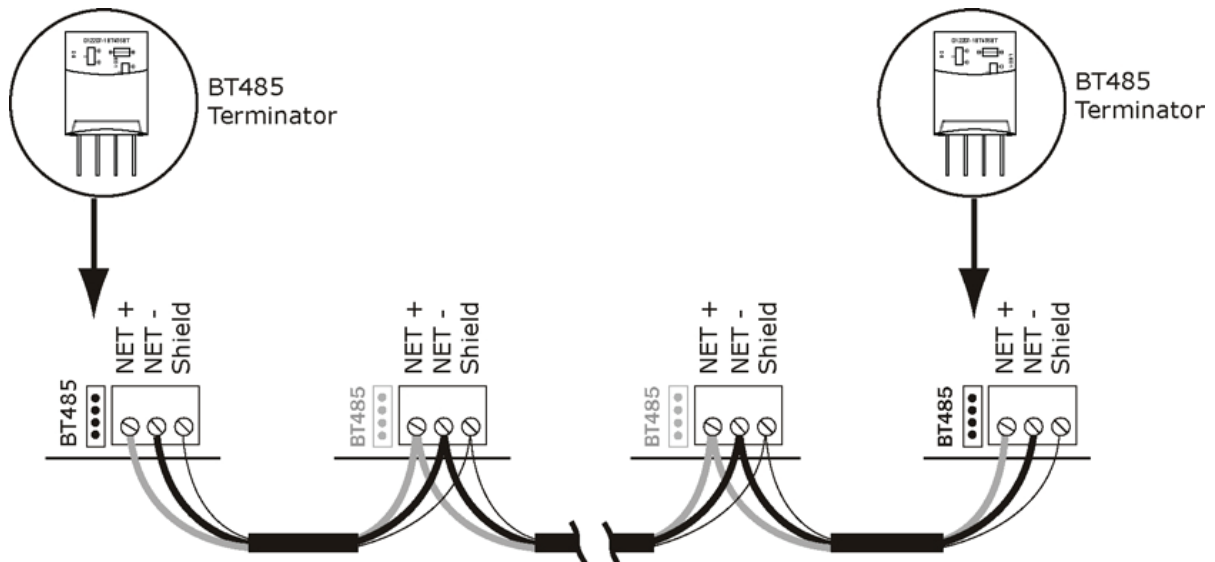

Fig. D — Network Wiring

APPENDIX B — OPTIONAL BACNET COMMUNICATIONS WIRING (cont)

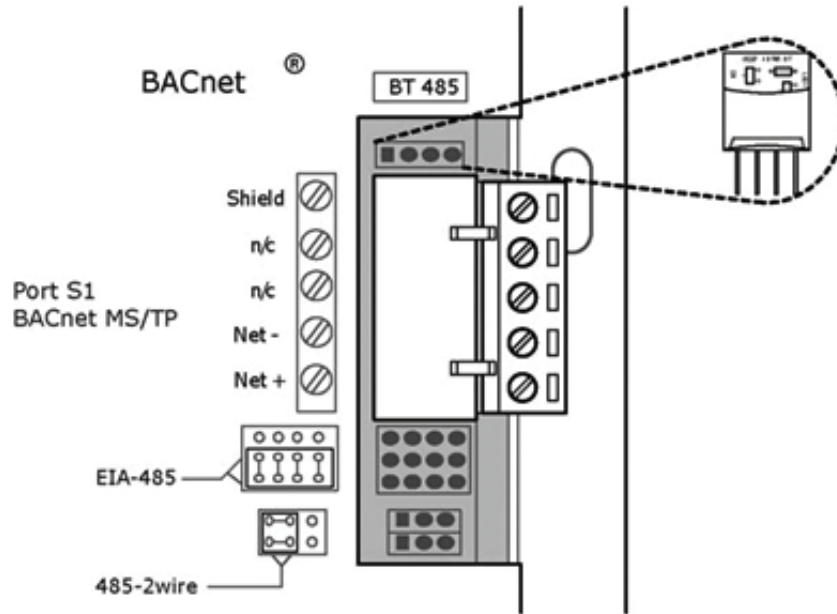

Fig. E — BT485 Terminator Installation

To install a BT485 terminator, push the BT485 terminator on to the BT485 connector located near the BACnet connector.
NOTE: The BT485 terminator has no polarity associated with it.

To order a BT485 terminator, consult Commercial Products i-Vu Open Control System Master Prices.

MS/TP WIRING RECOMMENDATIONS — Recommendations are shown in Tables C and D. The wire jacket and UL

temperature rating specifications list two acceptable alternatives. The Halar specification has a higher temperature rating and a tougher outer jacket than the SmokeGard specification, and it is appropriate for use in applications where the user is concerned about abrasion. The Halar jacket is also less likely to crack in extremely low temperatures.

NOTE: Use the specified type of wire and cable for maximum signal integrity.

Table C — MS/TP Wiring Recommendations

SPECIFICATION	RECOMMENDATION
Cable	Single twisted pair, low capacitance, CL2P, 22 AWG (7x30), TC foam FEP, plenum rated cable
Conductor	22 or 24 AWG stranded copper (tin plated)
Insulation	Foamed FEP 0.015 in. (0.381 mm) wall 0.060 in. (1.524 mm) O.D.
Color Code	Black/White
Twist Lay	2 in. (50.8 mm) lay on pair 6 twists/foot (20 twists/meter) nominal
Shielding	Aluminum/Mylar shield with 24 AWG TC drain wire
Jacket	SmokeGard Jacket (SmokeGard PVC) 0.021 in. (0.5334 mm) wall 0.175 in. (4.445 mm) O.D. Halar Jacket (E-CTFE) 0.010 in. (0.254 mm) wall 0.144 in. (3.6576 mm) O.D.
DC Resistance	15.2 Ohms/1000 feet (50 Ohms/km) nominal
Capacitance	12.5 pF/ft (41 pF/meter) nominal conductor to conductor
Characteristic Impedance	100 Ohms nominal
Weight	12 lb/1000 feet (17.9 kg/km)
UL Temperature Rating	SmokeGard 167°F (75°C) Halar -40 to 302°F (-40 to 150°C)
Voltage	300 Vac, power limited
Listing	UL: NEC CL2P, or better

LEGEND

- AWG** — American Wire Gage
- CL2P** — Class 2 Plenum Cable
- DC** — Direct Current
- FEP** — Fluorinated Ethylene Polymer
- NEC** — National Electrical Code
- O.D.** — Outside Diameter
- TC** — Tinned Copper
- UL** — Underwriters Laboratories

APPENDIX B — OPTIONAL BACNET COMMUNICATIONS WIRING (cont)

Table D — Open System Wiring Specifications and Recommended Vendors

WIRING SPECIFICATIONS		RECOMMENDED VENDORS AND PART NUMBERS			
Wire Type	Description	Connect Air International	Belden	RMCORP	Contractors Wire and Cable
MS/TP Network (RS-485)	22 AWG, single twisted shielded pair, low capacitance, CL2P, TC foam FEP, plenum rated. See MS/TP Installation Guide for specifications.	W221P-22227	—	25160PV	CLP0520LC
	24 AWG, single twisted shielded pair, low capacitance, CL2P, TC foam FEP, plenum rated. See MS/TP Installation Guide for specifications.	W241P-2000F	82841	25120-OR	—
Rnet	4 conductor, unshielded, CMP, 18 AWG, plenum rated.	W184C-2099BLB	6302UE	21450	CLP0442

LEGEND

AWG	— American Wire Gage
CL2P	— Class 2 Plenum Cable
CMP	— Communications Plenum Rated
FEP	— Fluorinated Ethylene Polymer
TC	— Tinned Copper

LOCAL ACCESS TO THE UPC OPEN CONTROLLER — The user can use a BACview⁶ handheld keypad display unit or the Virtual BACview software as a local user interface to an Open controller. These items let the user access the controller network information. These are accessory items and do not come with the UPC Open controller.

The BACview⁶ unit connects to the local access port on the UPC Open controller. See Fig. F. The BACview software must be running on a laptop computer that is connected to the local access port on the UPC Open controller. The laptop will require an additional USB link cable for connection.

See the *BACview Installation and User Guide* for instructions on connecting and using the BACview⁶ device.

To order a BACview⁶ Handheld (BV6H), consult Commercial Products i-Vu[®] Open Control System Master Prices.

CONFIGURING THE UPC OPEN CONTROLLER'S PROPERTIES — The UPC Open device and *ComfortLink*[™] controls must be set to the same CCN Address (Element) number and CCN Bus number. The factory default settings for CCN Element and CCN Bus number are 1 and 0 respectively.

If modifications to the default Element and Bus number are required, both the *ComfortLink* and UPC Open configurations must be changed.

The following configurations are used to set the CCN Address and Bus number in the *ComfortLink* control. These configurations can be changed using the scrolling marquee display or accessory Navigator handheld device.

Configuration → **CCN** → **CCN.A** (CCN Address)

Configuration → **CCN** → **CCN.B** (CCN Bus Number)

The following configurations are used to set the CCN Address and Bus Number in the UPC Open controller. These configurations can be changed using the accessory BACview⁶ display.

Navigation: BACview → CCN

Home: Element Comm Stat

Element: 1

Bus: 0

TROUBLESHOOTING — If there are problems wiring or addressing the UPC Open controller, contact Carrier Technical Support.

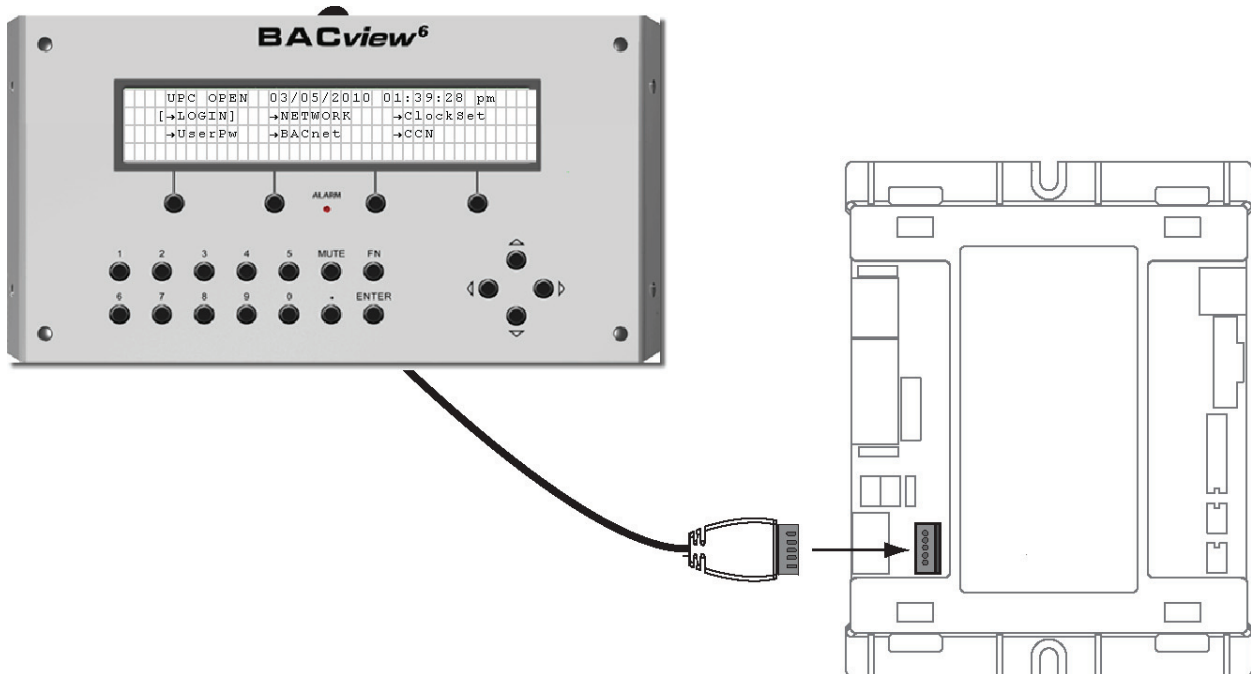

Fig. F — BACview⁶ Device Connection

APPENDIX B — OPTIONAL BACNET COMMUNICATIONS WIRING (cont)

COMMUNICATION LEDS — The LEDs indicate if the controller is communicating with the devices on the network. See Tables E and F. The LEDs should reflect communication traffic based on the baud rate set. The higher the baud rate the more solid the LEDs become. See Fig. A for location of LEDs on UPC Open module.

REPLACING THE UPC OPEN BATTERY — The UPC Open controller's 10-year lithium CR2032 battery provides a minimum of 10,000 hours of data retention during power outages.

IMPORTANT: Power must be **ON** to the UPC Open controller when replacing the battery, or the date, time, and trend data will be lost.

Remove the battery from the controller, making note of the battery's polarity. Insert the new battery, matching the battery's polarity with the polarity indicated on the UPC Open controller.

NETWORK POINTS LIST — The points list for the controller is shown in Table G.

Table E — LED Status Indicators

LED	STATUS
Power	Lights when power is being supplied to the controller. The UPC Open controller is protected by internal solid-state polyswitches on the incoming power and network connections. These polyswitches are not replaceable and will reset themselves if the condition that caused the fault returns to normal.
Rx	Lights when the controller receives data from the network segment; there is an Rx LED for Ports 1 and 2.
Tx	Lights when the controller transmits data to the network segment; there is a Tx LED for Ports 1 and 2.
Run	Lights based on controller status. See Table F.
Error	Lights based on controller status. See Table F.

Table F — Run and Error LEDs Controller and Network Status Indication

RUN LED	ERROR LED	STATUS
2 flashes per second	Off	Normal
2 flashes per second	2 flashes, alternating with Run LED	Five minute auto-restart delay after system error
2 flashes per second	3 flashes, then off	Controller has just been formatted
2 flashes per second	1 flash per second	Controller is alone on the network
2 flashes per second	On	Exec halted after frequent system errors or control programs halted
5 flashes per second	On	Exec start-up aborted, Boot is running
5 flashes per second	Off	Firmware transfer in progress, Boot is running
7 flashes per second	7 flashes per second, alternating with Run LED	Ten second recovery period after brownout
14 flashes per second	14 flashes per second, alternating with Run LED	Brownout

APPENDIX B — OPTIONAL BACNET COMMUNICATIONS WIRING (cont)

Table G — Network Points List

POINT DESCRIPTION	CCN POINT NAME	READ/ WRITE	UNITS	DEFAULT VALUE	RANGE	BACNET OBJECT ID	BACNET OBJECT NAME
1st Current Alarm State	ALARM_01	R		N/A	0-270	AV:4	alarm_01_1
Active Demand Limit	DEM_LIM	R/W	%	N/A	40 to 100	AV:6	dem_lim_1
Actual Guide Vane Position	GV_POS	R	%	N/A	0 to 100	AV:7	gv_pos_1
Actual VFD Speed	VFD_ACT	R	%	N/A	0 to 110	AV:11	vfd_act_1
Calc Evap Sat Temp	EAT	R	°F	N/A	-40 to 245	AV:13	ert_1
Chilled Water Deadband	CWDB	R	^F	1.0	0.5 to 2.0	AV:14	cwdb_1
Chilled Water Delta P	CHWPD	R	^F	N/A	-6.7 to 420	AV:15	chwpd_1
Chilled Water Delta T	CHW_DT	R	^F	N/A	-40 to 245	AV:16	chw_dt_1
Chilled Water Pump	CHLP	R	N/A	OFF	OFF/ON	BV:4	chlp_1
Chilled Water Temp	CHW_TMP	R	°F	N/A	-40 to 245	AV:17	chw_tmp_1
Chiller Start/Stop	CHIL_S_S	R/W	N/A	STOP	STOP/START	BV:5	chil_s_s_1
Comp Discharge Temp	CMPD	R	°F	N/A	-40 to 245	AV:18	cmpd_1
Comp Motor Winding Temp	MTRW	R	°F	N/A	-40 to 245	AV:19	mtrw_1
Comp Thrust Brg Temp	MTRB	R	°F	N/A	-40 to 245	AV:20	mtrb_1
Cond Water Flow	CDW_FLOW	R	N/A	NO	NO/YES	BV:6	cdw_flow_1
Cond Water Pump	CDP	R	N/A	OFF	OFF/ON	BV:7	cdp_1
Condenser Pressure	CRP	R	PSI	N/A	-6.7 to 420	AV:21	crp_1
Condenser Refrig Temp	CRT	R	°F	N/A	-40 to 245	AV:22	crt_1
Condenser Water Delta P	CDWPD	R	PSI	N/A	-6.7 to 420	AV:23	cdwpd_1
Control Point	LCW_STPT	R/W	°F	N/A	10 to 120	AV:24	lcw_stpt_1
Current CHW Setpoint	CHWSTPT	R	°F	N/A	0.00 to 99.9	AV:25	chwstpt_1
Demand Level 1	N/A	R	%	N/A	0 to 100	AV:1	dmv_lvl_1_perct_1
Demand Level 2	N/A	R	%	N/A	0 to 100	AV:2	dmv_lvl_2_perct_1
Demand Level 3	N/A	R	%	N/A	0 to 100	AV:3	dmv_lvl_3_perct_1
Element Comm Status	N/A	R	N/A	N/A	No Comm/Normal	BV:2999	element_stat_1
Element Communications Alarm	N/A	R	N/A	N/A	Inactive/Active	BV:20	comm_lost_alm_1
Emergency Stop	EMSTOP	R	N/A	ENABLE	ENABLE/ EMSTOP	BV:8	emstop_1
Entering Chilled Water	ECW	R	°F	N/A	-40 to 245	AV:26	ecw_1
Entering Condenser Water	ECDW	R	°F	N/A	-40 to 245	AV:27	ecdw_1
Equipment Alarm	N/A	R	N/A	N/A	Comm Normal Comm Lost	BV:1	element_alarm_1
Evaporator Pressure	ERP	R	PSI	N/A	-6.7 to 420	AV:28	erp_1
Evaporator Refrigerant Temp	ERT	R	°F	N/A	-40 to 245	AV:13	ert_1
Leaving Chilled Water - Prime Variable	LCW	R	°F	N/A	-40 to 245	AV:31	lcw_1
Leaving Condenser Water	LCDW	R	°F	N/A	-40 to 245	AV:32	lcdw_1
Line Active Current	AMPS_ACT	R	A	N/A	0.0 to 99999.0	AV:8	amps_act_1
Line Active Voltage	VOLT_ACT	R	V	N/A	0.0 to 99999.0	AV:9	volt_act_1
Line Frequency	LINEFREQ	R	Hz	N/A	0 to 99	AV:30	linefreq_1
Line Power Factor	LINE_PF	R		N/A	0.00 to 2.00	AV:34	line_pf_1
Local Schedule	N/A	R	N/A	N/A	No Comm/Normal	BV:2	schedule_1
Occupied?	OCC	R	N/A	NO	NO/YES	BV:10	occ_1
Oil Sump Temperature	OILT	R	°F	N/A	-40 to 245	AV:33	oilt_1
Remote Start Contact	REM_CON	R/W	N/A	OPEN	OPEN/CLOSE	BV:11	rem_con_1
Run Status	STATUS	R	N/A	N/A	0=Timeout, 1=Ready, 2=Recyle, 3=Startup, 4=Running, 5=Demand, 6=Ramping, 7=Autorest, 8=Override, 9=Tripout, 10=Control Test, 11=Lockout, 12=Pumpdown, 13=Prestart	AV:35	status_1
Service Overtime	S_HRS	R/W	hr	N/A	0 to 32767	AV:36	s_hrs_1
Surge Line Delta T	DELTA_TX	R	°F	N/A	0 to 200	AV:38	delta_tx_1
System Alert/Alarm	SYS_ALM	R	N/A	N/A	1=Normal, 2=Alert, 3=Alarm	AV:40	sys_alm_1

APPENDIX B — OPTIONAL BACNET COMMUNICATIONS WIRING (cont)

Table G — Network Points List (cont)

POINT DESCRIPTION	CCN POINT NAME	READ/ WRITE	UNITS	DEFAULT VALUE	RANGE	BACNET OBJECT ID	BACNET OBJECT NAME
System Cooling Demand Level	N/A	R	N/A	N/A	N/A	AV:9006	cool_demand_level_1
System Demand Limiting	N/A	R	N/A	N/A	OFF/ON	BV:3	dem_lmt_act_1
Target Guide Vane Position	GV_TRG	R	%	N/A	0 to 100	AV:41	gv_trg_1
Target VFD Speed	VFD_OUT	R	%	N/A	0 to 100	AV:42	vfd_out_1
Tower Fan Relay High	TFR_HIGH	R	N/A	OFF	OFF/ON	BV:13	tfr_high_1
Tower Fan Relay Low	TFR_LOW	R	N/A	OFF	OFF/ON	BV:14	tfr_low_1
User Defined Analog 1	N/A	R	N/A	N/A	N/A	AV:2901	user_analog_1_1
User Defined Analog 2	N/A	R	N/A	N/A	N/A	AV:2902	user_analog_2_1
User Defined Analog 3	N/A	R	N/A	N/A	N/A	AV:2903	user_analog_3_1
User Defined Analog 4	N/A	R	N/A	N/A	N/A	AV:2904	user_analog_4_1
User Defined Analog 5	N/A	R	N/A	N/A	N/A	AV:2905	user_analog_5_1
User Defined Binary 1	N/A	R	N/A	N/A	N/A	BV:2911	user_binary_1_1
User Defined Binary 2	N/A	R	N/A	N/A	N/A	BV:2912	user_binary_2_1
User Defined Binary 3	N/A	R	N/A	N/A	N/A	BV:2913	user_binary_3_1
User Defined Binary 4	N/A	R	N/A	N/A	N/A	BV:2914	user_binary_4_1
User Defined Binary 5	N/A	R	N/A	N/A	N/A	BV:2915	user_binary_5_1

LEGEND

- CHW** — Chilled Water
- R** — Read
- VFD** — Variable Frequency Drive
- W** — Write

NOTE: Network Points List is subject to change. Consult most recent service bulletins for latest information.