

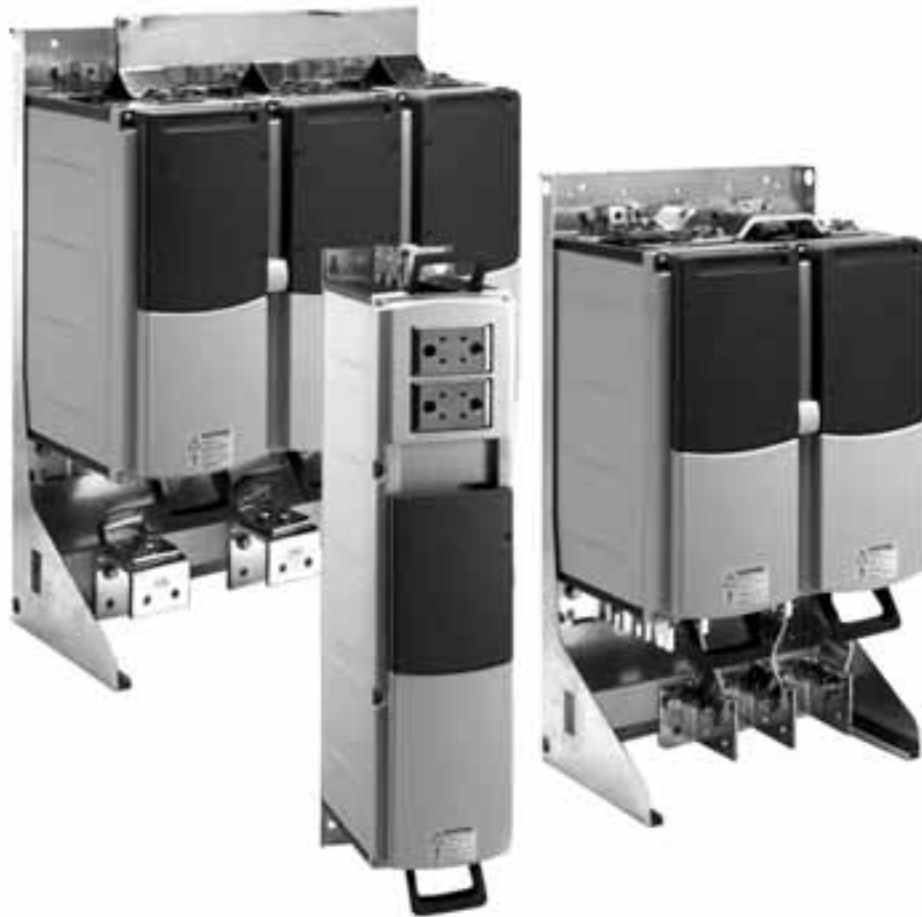


# Cutler-Hammer

## LCX9000 Liquid-Cooled Drives

User Manual

September 2007  
Supersedes January 2007





September 2007

**Important Notice — Please Read**

The product discussed in this literature is subject to terms and conditions outlined in Eaton Electrical Inc. selling policies. The sole source governing the rights and remedies of any purchaser of this equipment is the relevant Eaton Electrical Inc. selling policy.

NO WARRANTIES, EXPRESS OR IMPLIED, INCLUDING WARRANTIES OF FITNESS FOR A PARTICULAR PURPOSE OR MERCHANTABILITY, OR WARRANTIES ARISING FROM COURSE OF DEALING OR USAGE OF TRADE, ARE MADE REGARDING THE INFORMATION, RECOMMENDATIONS AND DESCRIPTIONS CONTAINED HEREIN. In no event will Eaton Electrical Inc. be responsible to the purchaser or user in contract, in tort (including negligence), strict liability or otherwise for any special, indirect, incidental or consequential damage or loss whatsoever, including but not limited to damage or loss of use of equipment, plant or power system, cost of capital, loss of power, additional expenses in the use of existing power facilities, or claims against the purchaser or user by its customers resulting from the use of the information, recommendations and descriptions contained herein.

The information contained in this manual is subject to change without notice.

Cover Photo: Cutler-Hammer® LCX9000 Liquid-Cooled Drive.

## Table of Contents

<b>LIST OF FIGURES</b> .....	iii
<b>LIST OF TABLES</b> .....	v
<b>SAFETY</b> .....	vii
Definitions and Symbols .....	vii
Hazardous High Voltage .....	vii
Warnings, Cautions and Notices .....	viii
<b>CHAPTER 1 — OVERVIEW</b> .....	1-1
Receiving and Inspection .....	1-1
Storage and Shipping .....	1-3
Maintenance .....	1-3
Technical Data .....	1-3
<b>CHAPTER 2 — INSTALLATION</b> .....	2-1
Mounting .....	2-1
Cooling .....	2-12
Drive Derating .....	2-23
Input Chokes .....	2-24
Inverter Charging Circuit .....	2-28
<b>CHAPTER 3 — POWER WIRING</b> .....	3-1
Power Connections .....	3-1
Cable Installation Instructions .....	3-10
Installation Space .....	3-12
Grounding of Power Unit .....	3-13
Cable Installation and the UL Standards .....	3-13
Cable and Motor Insulation Checks .....	3-14
<b>CHAPTER 4 — CONTROL WIRING AND INTERNAL CONNECTIONS</b> .....	4-1
Control Board Power-Up .....	4-3
Control Connections .....	4-4
Control Terminal Signals .....	4-7
Control Unit Mounting Box .....	4-10
Internal Connections .....	4-13
<b>CHAPTER 5 — MENU INFORMATION</b> .....	5-1
Keypad Operation .....	5-1
Indicators on the Keypad Display .....	5-1
Keypad Pushbuttons .....	5-3
Menu Navigation .....	5-5
Further Keypad Functions .....	5-30
<b>CHAPTER 6 — START-UP</b> .....	6-1
Safety Precautions .....	6-1
Sequence of Operation .....	6-2
<b>CHAPTER A — FAULT CODES</b> .....	A-1
Load Test with Motor .....	A-4
DC Link Test (without Motor) .....	A-5
<b>CHAPTER B — TECHNICAL REFERENCE</b> .....	B-1
Main Circuit and Control Diagrams .....	B-1
Fan Dimensions .....	B-13

September 2007

## List of Figures

Figure 1-1: Liquid-Cooled Drive Principal Block Diagram .....	1-5
Figure 1-2: Liquid-Cooled Drive DC Block Diagram .....	1-6
Figure 2-1: Lifting Points for Drives Consisting of One Module (Left) and Several Modules .....	2-1
Figure 2-2: LCX9000 Liquid-Cooled Drive, CH3 .....	2-2
Figure 2-3: LCX9000 Liquid-Cooled Drive, CH4 .....	2-3
Figure 2-4: LCX9000 Liquid-Cooled Drive, CH5 .....	2-3
Figure 2-5: LCX9000 Liquid-Cooled Inverter, CH5 .....	2-4
Figure 2-6: LCX9000 Liquid-Cooled Drive, CH61 .....	2-4
Figure 2-7: LCX9000 Liquid-Cooled Inverter, CH61 .....	2-5
Figure 2-8: LCX9000 Liquid-Cooled Inverter, CH62 .....	2-5
Figure 2-9: LCX9000 Liquid-Cooled Drive, CH72 .....	2-6
Figure 2-10: Drive Mounted Inside Mounting Bracket .....	2-7
Figure 2-11: LCX9000 Liquid-Cooled Drive with Mounting Bracket, CH63 .....	2-8
Figure 2-12: LCX9000 Liquid-Cooled Inverter with Mounting Bracket, CH63 .....	2-9
Figure 2-13: LCX9000 Liquid-Cooled Inverter with Mounting Bracket, CH64, IP90 .....	2-10
Figure 2-14: LCX9000 Liquid-Cooled Drive, CH74, IP00 .....	2-11
Figure 2-15: Example of Cooling System .....	2-14
Figure 2-16: Example PI-Diagram of Cooling System and Connections .....	2-15
Figure 2-17: Safe Operating Conditions in Relation to Condensation .....	2-17
Figure 2-18: Aluminum Hose Adapters .....	2-18
Figure 2-19: External Thread of Hose Adapter .....	2-18
Figure 2-20: Pressure Loss — CH6x .....	2-19
Figure 2-21: Pressure Loss — CH7x .....	2-20
Figure 2-22: Flow Switch: Hose Connection, Fast Connector (Electrical), Fast Connector Lock Screw, Cable Seal and Clamp .....	2-21
Figure 2-23: Direction of Coolant Circulation .....	2-22
Figure 2-24: Example of Input Chokes for Liquid-Cooled Sizes Up to 62A .....	2-25
Figure 2-25: Example of Input Chokes for Liquid-Cooled Sizes 87 – 145A and 590A .....	2-25
Figure 2-26: Example of Input Chokes for Liquid-Cooled Sizes 261 – 1150A .....	2-27
Figure 2-27: Charging Circuit .....	2-28
Figure 3-1: Maximum Terminal Stresses .....	3-12
Figure 3-2: Installation Space .....	3-12
Figure 3-3: Grounding Terminal on Mounting Plate .....	3-13
Figure 4-1: Control Board .....	4-1
Figure 4-2: Basic and Option Board Connections of the Control Board .....	4-2
Figure 4-3: Drives Connected in Parallel .....	4-2
Figure 4-4: Connection of Control Board Cable from the Power Board WRONG: Terminal J1 (Upper) .....	4-3
Figure 4-5: Connection of Control Board Cable from the Power Board CORRECT: Terminal J2 (Lower) .....	4-4
Figure 4-6: I/O Terminals of the Two Basic Boards .....	4-4
Figure 4-7: General Wiring Diagram of the Basic I/O Board (OPT-A9) .....	4-5
Figure 4-8: General Wiring Diagram of the Basic Relay Board (OPT-A2) .....	4-5
Figure 4-9: Galvanic Isolation Barriers .....	4-6
Figure 4-10: Positive/Negative Logic .....	4-8
Figure 4-11: Jumper Blocks on OPT-A9 .....	4-8
Figure 4-12: Jumper Selection for OPT-A9 .....	4-9
Figure 4-13: Control Unit Mounting Box .....	4-10

## List of Figures, Continued

Figure 4-14: Control Unit Installed into the Mounting Box; Left: Front; Right: Back .....	4-10
Figure 4-15: Terminals and Connections between ASIC and Driver Board (CH61, CH62 and CH72) .....	4-14
Figure 4-16: Terminals and Connections between ASIC and Driver Board (CH63) .....	4-15
Figure 4-17: Terminals and Connections between ASIC and Driver Boards (CH64 and CH74) .....	4-16
Figure 4-18: Remove Cover to Access Power Unit .....	4-17
Figure 4-19: Optical Cable Adapter Board .....	4-18
Figure 5-1: Control Keypad and Drive Status Indications .....	5-1
Figure 5-2: Keypad Pushbuttons .....	5-3
Figure 5-3: Keypad Display Data .....	5-5
Figure 5-4: Keypad Navigation Chart .....	5-6
Figure 5-5: Monitoring Menu .....	5-7
Figure 5-6: Parameter Value Change Procedure .....	5-9
Figure 5-7: Selection of Control Place .....	5-10
Figure 5-8: Normal State, No Faults .....	5-11
Figure 5-9: Fault Display .....	5-12
Figure 5-10: Fault History Menu .....	5-14
Figure 5-11: Selection of Language .....	5-17
Figure 5-12: Change of Application .....	5-17
Figure 5-13: Storing and Loading of Parameter Sets .....	5-18
Figure 5-14: Parameter Copy to Keypad .....	5-19
Figure 5-15: Parameter Comparison .....	5-20
Figure 5-16: Password Setting .....	5-21
Figure 5-17: Parameter Locking .....	5-22
Figure 5-18: Activation of Start-Up Wizard .....	5-22
Figure 5-19: Disabling the Change of Multimonitoring Items .....	5-23
Figure 5-20: Keypad Settings Submenu .....	5-23
Figure 5-21: Default Page Function .....	5-23
Figure 5-22: Timeout Time Setting .....	5-24
Figure 5-23: HMI Acknowledge Timeout .....	5-25
Figure 5-24: Counter Reset .....	5-27
Figure 5-25: Applications Info Submenu .....	5-28
Figure 5-26: Expander Board Information Menus .....	5-29
Figure 5-27: Expander Board Information Menu .....	5-30
Figure B-1: Main Circuit and Control Diagram, CH3 .....	B-1
Figure B-2: Main Circuit and Control Diagram, CH4 .....	B-2
Figure B-3: Main Circuit and Control Diagram, CH5 .....	B-2
Figure B-4: Main Circuit and Control Diagram, CH61 .....	B-3
Figure B-5: Main Circuit and Control Diagram, CH61, Control .....	B-3
Figure B-6: Inverter Circuit Diagram, CH61 .....	B-4
Figure B-7: Inverter Circuit and Control Diagram, CH61 .....	B-4
Figure B-8: Inverter Circuit Diagram, CH62 .....	B-5
Figure B-9: Inverter Circuit and Control Diagram, CH62 .....	B-5
Figure B-10: Main Circuit and Control Diagram, CH63, Module 1 .....	B-6
Figure B-11: Main Circuit and Control Diagram, CH63, Module 2 .....	B-6
Figure B-12: Main Circuit and Control Diagram, CH63, Control .....	B-7
Figure B-13: Inverter Circuit Diagram, CH63, Module 1 .....	B-7

September 2007

## List of Figures, Continued

Figure B-14: Inverter Circuit Diagram, CH63, Module 2 . . . . .	B-8
Figure B-15: Inverter Circuit Diagram, CH63, Control . . . . .	B-8
Figure B-16: Inverter Circuit Diagram, CH64, Phase U . . . . .	B-9
Figure B-17: Inverter Circuit Diagram, CH64, Control . . . . .	B-9
Figure B-18: Main Circuit and Control Diagram, CH72 . . . . .	B-10
Figure B-19: Main Circuit and Control Diagram, CH72, Control . . . . .	B-10
Figure B-20: Main Circuit and Control Diagram, CH74, Phase U . . . . .	B-11
Figure B-21: Main Circuit and Control Diagram, CH74, Control . . . . .	B-12
Figure B-22: Fan Mounting Pallet — Hot Dip Zinc Coated . . . . .	B-13
Figure B-23: Fan Support . . . . .	B-13

## List of Tables

Table 1-1: LCX9000 Liquid-Cooled Adjustable Frequency Drive Catalog Numbering System . . . . .	1-2
Table 1-2: Power Ratings and Dimensions of Liquid-Cooled Drive, Supply Voltage 380 – 500V AC . . . . .	1-7
Table 1-3: Power Ratings and Dimensions of Liquid-Cooled Drive, Supply Voltage 525 – 690V AC . . . . .	1-9
Table 1-4: Power Ratings and Dimensions of Liquid-Cooled Inverter Unit, Supply Voltage 540 – 675V DC. . . . .	1-10
Table 1-5: Power Ratings and Dimensions of Liquid-Cooled Inverter Unit, Supply Voltage 710 – 930V DC. . . . .	1-12
Table 1-6: Technical Information. . . . .	1-14
Table 2-1: One-Module Drive Dimensions (Mounting Base Included). . . . .	2-2
Table 2-2: Several Module Drive Dimensions (Mounting Bracket Included). . . . .	2-7
Table 2-3: Drinking Water Chemical Specification. . . . .	2-12
Table 2-4: Drinking Water Quality Recommendations — Maximum Values. . . . .	2-12
Table 2-5: Drinking Water Quality Recommendations — Desired Values . . . . .	2-13
Table 2-6: Process Water Specification. . . . .	2-13
Table 2-7: Information About Cooling Agent and Its Circulation. . . . .	2-15
Table 2-8: Cooling Agent Flow Rates (GPM) in Relation to Power Loss at Certain Glycol/Water Mixture . . . . .	2-16
Table 2-9: Coolant Volumes and Temperatures. . . . .	2-16
Table 2-10: Liquid Connector Types (All Pressure Values at Nominal Flow). . . . .	2-18
Table 2-11: Pressure Losses — CH6x . . . . .	2-19
Table 2-12: Pressure Losses — CH7x . . . . .	2-20
Table 2-13: Flow Switch Data . . . . .	2-21
Table 2-14: Maximum Temperatures of Coolant at Switching Frequency of 3.6 kHz . . . . .	2-23
Table 2-15: Maximum Temperatures of Coolant at Switching Frequency of 1.5 kHz . . . . .	2-23
Table 2-16: Input Choke Dimensioning, 6-Pulse Supply . . . . .	2-24
Table 2-17: Choke Dimensions Sizes 23 – 145A and 590A . . . . .	2-26
Table 2-18: Choke Dimensions Sizes 261 – 1150A. . . . .	2-27
Table 2-19: Resistor Used for Charging Circuits . . . . .	2-28
Table 3-1: Cable Types Required to Meet Standards . . . . .	3-2
Table 3-2: Cable Sizes 400 – 500V . . . . .	3-2
Table 3-3: Cable Sizes 525 – 690V . . . . .	3-4
Table 3-4: Tightening Torques of Bolts . . . . .	3-4
Table 3-5: Fuse Sizes for LCX9000 Liquid-Cooled (500V) Drives . . . . .	3-5
Table 3-6: Fuse Sizes for LCX9000 Liquid-Cooled (690V) Drives . . . . .	3-6
Table 3-7: Fuse Sizes for LCX9000 Liquid-Cooled (450 – 800V) Inverters . . . . .	3-7

## List of Tables, Continued

Table 3-8: Fuse Sizes for LCX9000 Liquid-Cooled (640 – 1100V) Inverters . . . . .	3-8
Table 3-9: Fuse Sizes for LCX9000 AFE Units (380 – 500V) . . . . .	3-9
Table 3-10: Fuse Sizes for LCX9000 AFE Units (525 – 690V) . . . . .	3-10
Table 4-1: Control I/O Terminal Signals. . . . .	4-7
Table 4-2: Installing the Control Unit Mounting Box . . . . .	4-11
Table 4-3: Terminals (CH61, CH62 and CH72) . . . . .	4-14
Table 4-4: Terminals (CH63) . . . . .	4-15
Table 4-5: Terminals between Driver Boards (CH64 and CH74) . . . . .	4-16
Table 4-6: Terminals on Adapter Board. . . . .	4-18
Table 5-1: Drive Status Indicators . . . . .	5-2
Table 5-2: Control Place Indicators . . . . .	5-2
Table 5-3: Status LEDs (Green – Green – Red) . . . . .	5-3
Table 5-4: Text Lines . . . . .	5-3
Table 5-5: Button Descriptions . . . . .	5-4
Table 5-6: Monitored Signals . . . . .	5-8
Table 5-7: Keypad Control Parameters, M3 . . . . .	5-9
Table 5-8: Fault Types . . . . .	5-12
Table 5-9: Fault Time Recorded Data. . . . .	5-13
Table 5-10: Real Time Record. . . . .	5-13
Table 5-11: System Menu Functions . . . . .	5-15
Table 5-12: Counter Pages . . . . .	5-26
Table 5-13: Resettable Counters . . . . .	5-27
Table 5-14: Software Information Pages. . . . .	5-27
Table 5-15: Applications Information Pages . . . . .	5-28
Table 5-16: Hardware Information Pages . . . . .	5-28
Table 5-17: Expander Board Parameters (Board OPTA1). . . . .	5-30
Table A-1: Fault Codes . . . . .	A-1



September 2007

## Safety

### Definitions and Symbols

---

** WARNING**

---

This symbol indicates high voltage. It calls your attention to items or operations that could be dangerous to you and other persons operating this equipment. Read the message and follow the instructions carefully.

---

** WARNING**

---

This symbol is the "Safety Alert Symbol." It occurs with either of two signal words: CAUTION or WARNING, as described below.

---

** WARNING**

---

Indicates a potentially hazardous situation which, if not avoided, can result in serious injury or death.

---

** CAUTION**

---

Indicates a potentially hazardous situation which, if not avoided, can result in minor to moderate injury, or serious damage to the product. The situation described in the CAUTION may, if not avoided, lead to serious results. Important safety measures are described in CAUTION (as well as WARNING).

### Hazardous High Voltage

---

** WARNING**

---

Motor control equipment and electronic controllers are connected to hazardous line voltages. When servicing drives and electronic controllers, there may be exposed components with housings or protrusions at or above line potential. Extreme care should be taken to protect against shock.

Stand on an insulating pad and make it a habit to use only one hand when checking components. Always work with another person in case an emergency occurs. Disconnect power before checking controllers or performing maintenance. Be sure equipment is properly grounded. Wear safety glasses whenever working on electronic controllers or rotating machinery.

## Warnings, Cautions and Notices

Read this manual thoroughly and make sure you understand the procedures before you attempt to install, set up, or operate this Cutler-Hammer® LCX9000 Drive from Eaton's electrical business.

### Warnings

---

**⚠ WARNING**

---

Only a competent electrician may carry out the electrical installation.

---

**⚠ WARNING**

---

The LCX9000 Liquid-Cooled drive is meant for fixed installations only.

---

**⚠ WARNING**

---

Do not perform any measurements when the drive is connected to the mains. Prior to measurements on the motor or the motor cable, disconnect the motor cable from the drive.

---

**⚠ WARNING**

---

The drive has a capacitive leakage current.

---

**⚠ WARNING**

---

If the drive is used as a part of a machine, the machine manufacturer is responsible for providing the machine with a main switch (EN 60204-1).

---

**⚠ WARNING**

---

Only spare parts delivered by Eaton can be used.

---

**⚠ WARNING**

---

The motor starts at power-up if the start command is "ON". Furthermore, the I/O functionalities (including start inputs) may change if parameters, applications or software are changed. Disconnect, therefore, the motor if an unexpected start can cause danger.

---

**⚠ WARNING**

---

The components of the power unit of the drive are **live** when it is connected to mains potential. **Coming into contact with this voltage is extremely dangerous and may cause death or severe injury.** The control unit is isolated from the mains potential.

September 2007

---

**⚠ WARNING**

---

The motor terminals U, V, W and the DC-link/brake resistor terminals are **live** when the Liquid-Cooled drive is connected to mains, **even if the motor is not running**.

---

**⚠ WARNING**

---

After disconnecting the drive from the mains, wait until the indicators on the keypad go out (if no keypad is attached see the indicators on the cover). Wait 5 more minutes before doing any work on the Liquid-Cooled drive connections. Do not touch the enclosure before this time has expired.

---

**⚠ WARNING**

---

The control I/O-terminals are isolated from the mains potential. However, the relay outputs and other I/O-terminals may have a dangerous control voltage present even when the Liquid-Cooled drive is disconnected from mains.

**Cautions**

---

**⚠ CAUTION**

---

Always remove all cooling agent from the cooling element(s) before shipping to avoid damage caused by freezing.

---

**⚠ CAUTION**

---

Do not perform any voltage withstand tests on any part of the Liquid-Cooled drive. There is a certain procedure according to which the tests shall be performed. Ignoring this procedure may result in damaged product.

---

**⚠ CAUTION**

---

Do not touch the components on the circuit boards. Electrostatic voltage discharge may damage the components.

---

**⚠ CAUTION**

---

Before connecting the Liquid-Cooled drive to mains, ensure the functionality of the coolant circulation and check the circulation for possible leaks.

---

**⚠ CAUTION**

---

Before connecting the drive to mains make sure that the enclosure door is closed.

**Grounding and Ground Fault Protection**

The LCX9000 drive must always be grounded with a ground conductor connected to the ground terminal.

The ground fault protection inside the drive only protects the drive against ground faults in the motor or the motor cable. It is not intended for personal safety.

Due to the high capacity currents present in the drive, fault current protective switches may not function properly.

**Motor and Equipment Safety**

---

**⚠ CAUTION**

---

Before starting the motor, check that the motor is mounted properly and ensure that the machine connected to the motor allows the motor to be started.

---

**⚠ CAUTION**

---

Set the maximum motor speed (frequency) according to the motor and the machine connected to it.

---

**⚠ CAUTION**

---

Before reversing the motor, make sure that this can be done safely.

---

**⚠ CAUTION**

---

Make sure that no power correction capacitors are connected to the motor cable.

---

**⚠ CAUTION**

---

Make sure that the motor terminals are not connected to mains potential.

---

**⚠ CAUTION**

---

Before the Liquid-Cooled drive can be used to control the motor, the proper functioning of the liquid-cooling system must be ensured.

September 2007

## Chapter 1 — Overview

### Receiving and Inspection

The standard delivery of Cutler-Hammer® Liquid-Cooled Drives from Eaton's electrical business includes all or part of the following components:

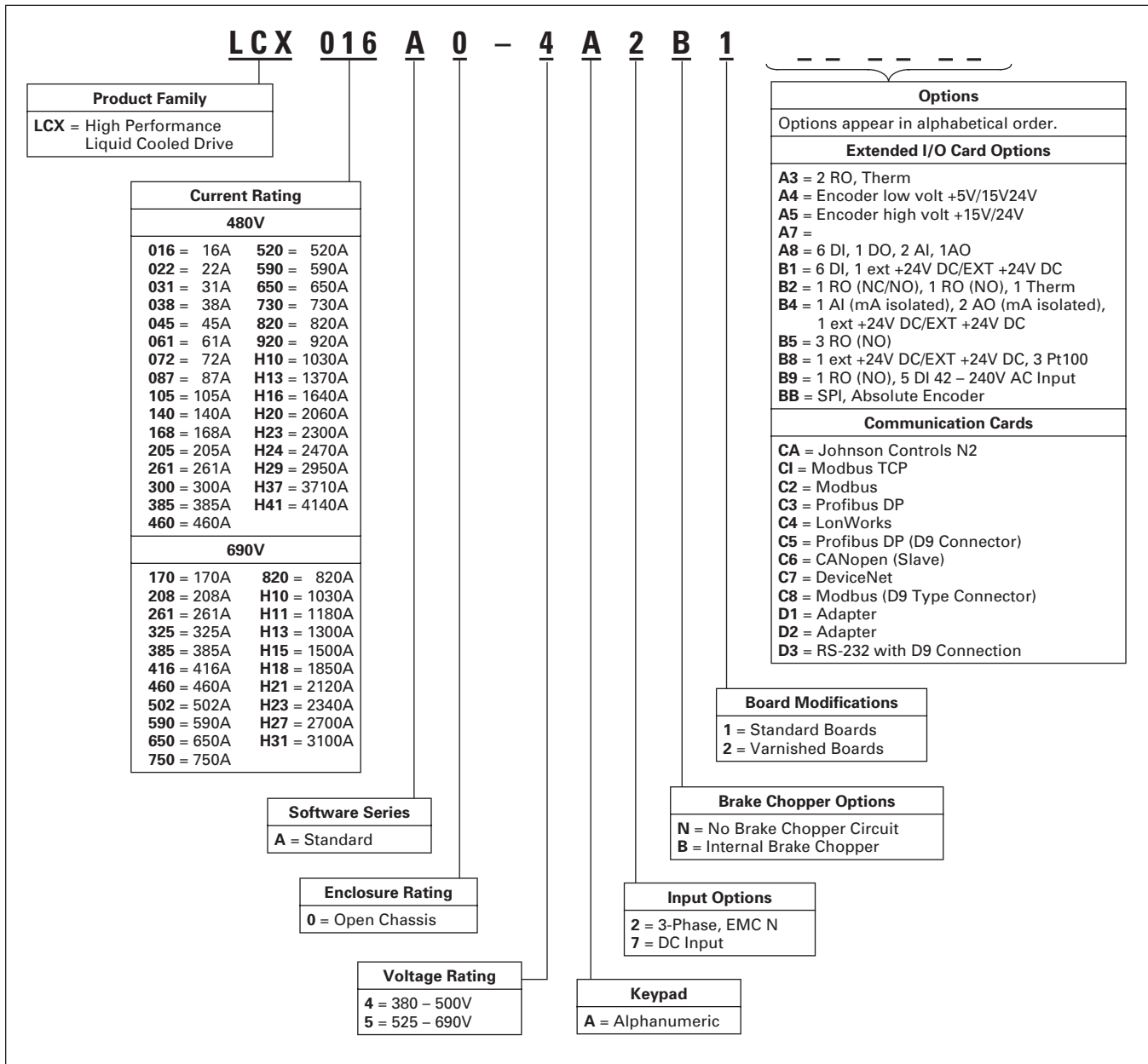
- power unit
- control unit
- water connection main line connecting hoses and conduits (1.5m) for CH61 – CH74; Hoses in different lengths also available
- Tema 1300 series fast connectors for CH3 – CH4
- choke
- control unit mounting kit
- cooling fan for boards (CH4)
- optic fiber & cable set (1.5m) for control unit; Optic sets in different lengths also available

Cutler-Hammer Liquid-Cooled Drives have undergone scrupulous tests and quality checks at the factory before they are delivered to the customer. However, after unpacking the product, check that no signs of transport damages are to be found on the product and that the delivery is complete (compare the type designation of the product to the code below, **Table 1-1**).

If the drive has been damaged during shipping, please contact the cargo insurance company or the carrier.

If the delivery does not correspond to your order, contact the supplier immediately.

**Table 1-1: LCX9000 Liquid-Cooled Adjustable Frequency Drive Catalog Numbering System**



September 2007

## Storage and Shipping

If the drive is to be kept in storage before use, make sure that the ambient conditions are acceptable:

Storing temperature -40 – 158°F (-40 – 70°C) (no cooling liquid inside cooling element allowed below 0°)

Relative humidity <96%, no condensation

If the storage time exceeds 12 months, the electrolytic DC capacitors need to be charged with caution. Therefore, such a long storage time is not recommended.

---

 **CAUTION**

---

Always remove all cooling agent from the cooling element(s) before shipping to avoid damage caused by freezing.

## Maintenance

In normal conditions, Cutler-Hammer Liquid-Cooled drives are maintenance-free. However, if the drive is used in conditions with temperatures below the freezing point and the liquid used for cooling is likely to freeze, **be sure to empty the cooling element if the drive must be moved or if it is taken out of use for a longer time.**

It may also be necessary to clean up the coolant ducts in the cooling element. Contact the factory for more information.

The instructions for the cooling system provided by its manufacturer must be followed.

## Technical Data

**Figure 1-1** presents the block diagram of the liquid-cooled drive. Mechanically, the product consists of two units, the Power Unit and the Control Unit. The power unit can contain one to six modules (cooling plates), depending on the drive size. Instead of air, liquid-cooled drives use liquid for cooling. A charging circuit is embodied in the drives.

An external three-phase AC-choke (1) at the mains input together with the DC-link capacitor (2) form an LC-filter. In drives, the LC-filter together with the diode bridge produce the DC-voltage supply to the IGBT Inverter Bridge (3) block. The AC-choke also functions as a filter against High Frequency disturbances from the mains as well as against those caused by the drive to the mains. In addition, it enhances the waveform of the input current to the drive. In chassis with multiple parallel line-rectifiers (CH74) AC-chokes are required to balance the line current between the rectifiers.

The power drawn by the drive from the mains is mostly active power.

The IGBT Inverter Bridge produces a symmetrical, three-phase Pulse Width Modulated AC-voltage to the motor.

The Motor and Application Control Block is based on microprocessor software. The microprocessor controls the motor based on the information it receives through measurements, parameter settings, control I/O and control keypad. The motor and application control block controls the motor control ASIC which, in turn, calculates the IGBT positions. Gate drivers amplify these signals for driving the IGBT inverter.

The control keypad constitutes a link between the user and the drive. The control keypad is used for parameter setting, reading status data and giving control commands. It is detachable and can be operated externally and connected via a cable to the drive. Instead of the control keypad, a PC can also be used to control the drive if connected through a similar cable ( $\pm 12V$ ).

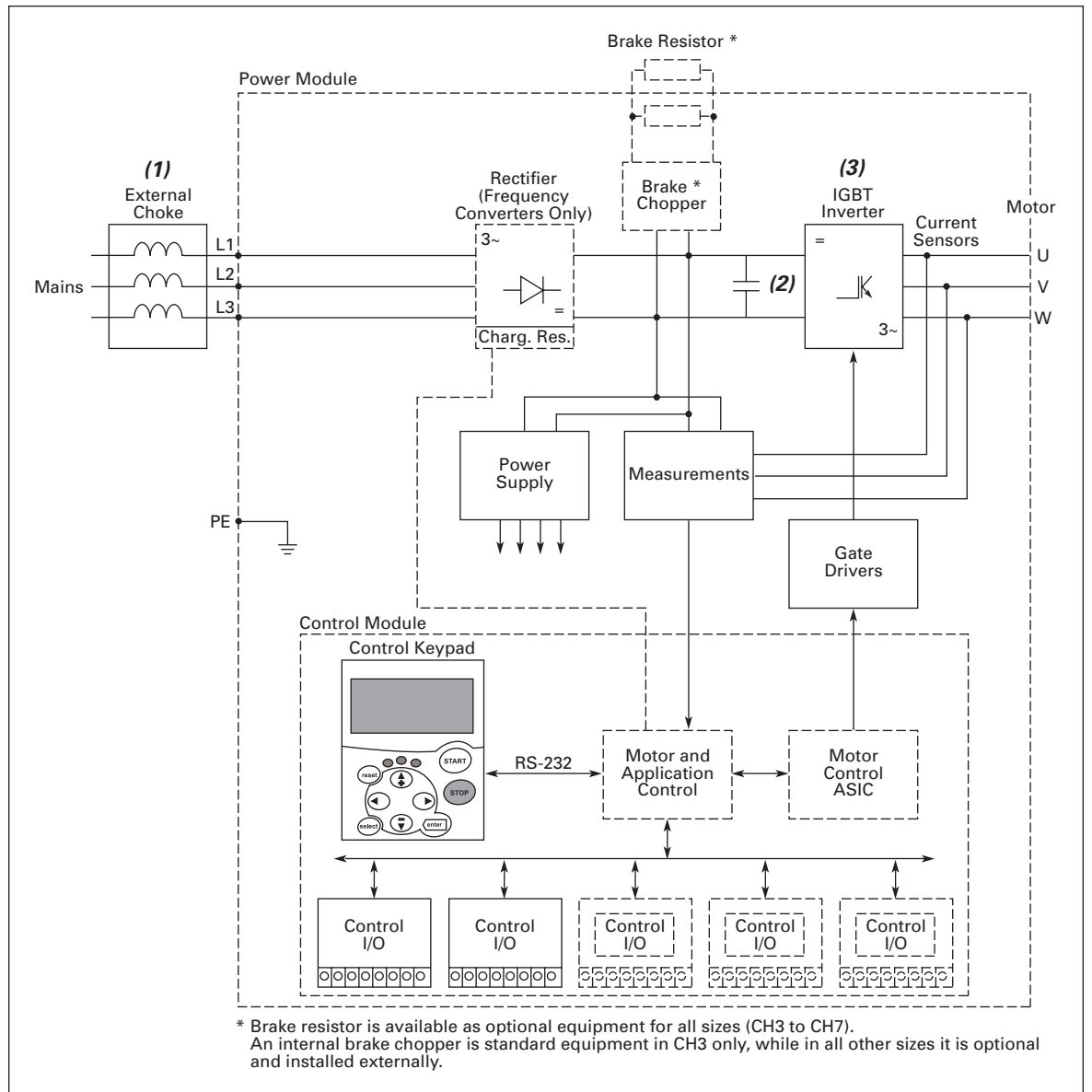
You can have your drive equipped with a control I/O board which is either isolated (OPT-A8) or not isolated (OPT-A9) from the frame. Optional I/O expander boards that increase the number of inputs and outputs to be used are also available. For more information, contact Eaton or your local distributor.

The basic control interface and the parameters (the Basic Application) are easy to use. If a more versatile interface or parameters are required, a more suitable application can be chosen from the application manual.

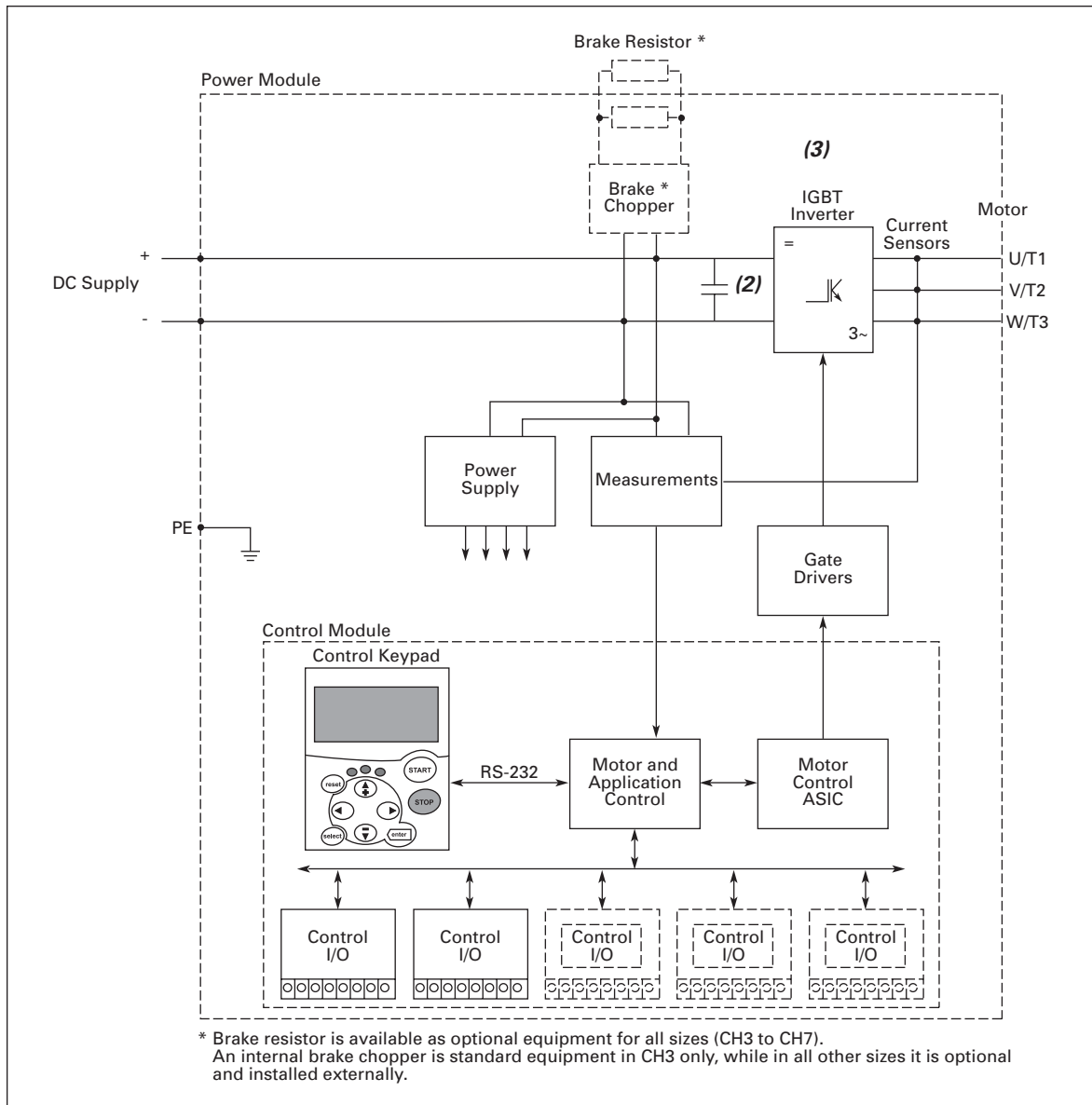
An internal brake chopper is available as standard for chassis CH3. For all other sizes the brake chopper is available as an option and installed externally. The standard product does not include a brake resistor. It should be ordered separately.



September 2007



**Figure 1-1: Liquid-Cooled Drive Principal Block Diagram**



**Figure 1-2: Liquid-Cooled Drive DC Block Diagram**

September 2007

**Power Ratings**

The Cutler-Hammer Liquid-Cooled product range consists of (AC input, AC output) drives. The following tables show the drive output values for both in  $I_{th}$  (current) and shaft power (electrical) as well as the drive losses and mechanical sizes. The power achieved is given as per the supply voltage.

**Drives**

**Table 1-2: Power Ratings and Dimensions of Liquid-Cooled Drive, Supply Voltage 380 – 500V AC**

Catalog Number	Drive Output					Power Loss c/a/T (kW)	Chassis
	Current			Electrical Output Power			
	Thermal $I_{th}$ (A)	Rated Cont. $I_L$ (A)	Rated Cont. $I_H$ (A)	Optimum Motor at $I_{th}$ 400V (kW)	Optimum Motor at $I_{th}$ 500V (kW)		
LCX016A0-4	16	15	11	7.5	11	0.4/0.2/0.6	CH3
LCX022A0-4	22	20	15	11	15	0.5/0.2/0.7	CH3
LCX031A0-4	31	28	21	15	18.5	0.7/0.2/0.9	CH3
LCX038A0-4	38	35	25	18.5	22	0.8/0.2/1.0	CH3
LCX045A0-4	45	41	30	22	30	1.0/0.3/1.3	CH3
LCX061A0-4	61	55	41	30	37	1.3/0.3/1.5	CH3
LCX072A0-4	72	65	48	37	45	1.2/0.3/1.5	CH4
LCX087A0-4	87	79	58	45	55	1.5/0.3/1.8	CH4
LCX105A0-4	105	95	70	55	75	1.8/0.3/2.1	CH4
LCX140A0-4	140	127	93	75	90	2.3/0.3/2.6	CH4
LCX168A0-4	168	153	112	90	110	4.0/0.4/4.4	CH5
LCX205A0-4	205	186	137	110	132	5.0/0.5/5.5	CH5
LCX261A0-4	261	237	174	132	160	6.0/0.5/6.5	CH5
LCX300A0-4	300	273	200	160	200	7.0/0.6/7.6	CH61
LCX385A0-4	385	350	257	200	250	9.0/0.7/9.7	CH61
LCX460A0-4	460	418	307	250	315	6.5/0.5/7.0	CH72
LCX520A0-4	520	473	347	250	355	7.5/0.6/8.1	CH72
LCX590A0-4	590	536	393	315	400	9.0/0.7/9.7	CH72
LCX650A0-4	650	591	433	355	450	10.0/0.7/10.7	CH72
LCX730A0-4	730	664	487	400	500	12.0/0.8/12.8	CH72

**Table 1-2: Power Ratings and Dimensions of Liquid-Cooled Drive, Supply Voltage 380 – 500V AC (Continued)**

Catalog Number	Drive Output					Power Loss c/a/T (kW)	Chassis
	Current			Electrical Output Power			
	Thermal $I_{th}$ (A)	Rated Cont. $I_L$ (A)	Rated Cont. $I_H$ (A)	Optimum Motor at $I_{th}$ 400V (kW)	Optimum Motor at $I_{th}$ 500V (kW)		
LCX820A0-4	820	745	547	450	560	12.5/0.8/13.3	CH63
LCX920A0-4	920	836	613	500	600	14.4/0.9/15.3	CH63
LCXH10A0-4	1030	936	687	560	700	16.5/1.0/17.5	CH63
LCXH11A0-4	1150	1045	766	600	750	18.5/1.2/19.7	CH63
LCXH13A0-4	1370	1245	913	700	900	19.0/1.2/20.2	CH74
LCXH16A0-4	1640	1491	1093	900	1100	24.0/1.4/25.4	CH74
LCXH20A0-4	2060	1873	1373	1100	1400	32.5/1.8/34.3	CH74
LCXH23A0-4	2300	2091	1533	1250	1500	36.3/2.0/38.3	CH74
LCXH24A0-4	2470	2245	1647	1300	1600	38.8/2.2/41.0	2xCH74
LCXH29A0-4	2950	2681	1967	1550	1950	46.3/2.6/48.9	2xCH74
LCXH37A0-4	3710	3372	2473	1950	2450	58.2/3.0/61.2	2xCH74
LCXH41A0-4	4140	3763	2760	2150	2700	65.0/3.6/68.6	2xCH74

$I_{th}$  = Thermal maximum continuous RMS current. Dimensioning can be done according to this current if the process does not require any overloadability or the process does not include any torque ripple.

$I_L$  = Low overloadability current. Allows +10% torque ripple. 10% exceeding can be continuous.

$I_H$  = High overloadability current. Allows +50% torque ripple. 50% exceeding can be continuous.

All values with  $\cos\phi = 0.83$  and efficiency = 97%.

c/a/T: c = power loss into coolant; a = power loss into air; **T = total power loss**; power losses of input chokes not included. All power losses obtained using max. supply voltage and switching frequency of 3.6 kHz.

If some other mains voltage is used, apply the formula  $P = \sqrt{3} \times Un \times In \times \cos\phi$  to calculate the Liquid-Cooled drive output power.

The enclosure class for all Liquid-Cooled drives is IP00.

September 2007

**Table 1-3: Power Ratings and Dimensions of Liquid-Cooled Drive, Supply Voltage 525 – 690V AC**

Catalog Number	Drive Output					Power Loss c/a/T (kW)	Chassis
	Current			Electrical Output Power			
	Thermal $I_{th}$ (A)	Rated Cont. $I_L$ (A)	Rated Cont. $I_H$ (A)	Optimum Motor at $I_{th}$ 525V (kW)	Optimum Motor at $I_{th}$ 690V (kW)		
LCX170A0-5	170	155	113	110	160	7.5/0.4/7.9	CH61
LCX208A0-5	208	189	139	132	200	9.0/0.5/9.5	CH61
LCX261A0-5	261	237	174	160	250	6.5/0.3/6.8	CH61
LCX325A0-5	325	295	217	200	300	7.5/0.4/7.9	CH72
LCX385A0-5	385	350	257	250	355	9.0/0.5/9.5	CH72
LCX416A0-5	416	378	277	250	355	9.4/0.5/9.9	CH72
LCX460A0-5	460	418	307	300	400	10.0/0.5/10.5	CH72
LCX502A0-5	502	456	335	355	450	12.0/0.6/12.6	CH72
LCX590A0-5	590	536	393	400	560	13.0/0.7/13.7	CH63
LCX650A0-5	650	591	433	450	600	16.0/0.8/16.8	CH63
LCX750A0-5	750	682	500	500	700	18.0/0.9/18.9	CH63
LCX820A0-5	820	745	547	560	800	19.0/1.0/20.0	CH74
LCX920A0-5	920	836	613	650	850	21.3/1.2/22.5	CH74
LCXH10A0-5	1030	936	687	700	1000	22.0/1.1/23.1	CH74
LCXH11A0-5	1180	1073	787	800	1100	25.0/1.3/26.3	CH74
LCXH13A0-5	1300	1182	867	900	1200	31.0/1.6/32.6	CH74
LCXH15A0-5	1500	1364	1000	1000	1400	38.0/1.9/39.9	CH74
LCXH18A0-5	1850	1682	1233	1250	1650	39.6/2.0/41.6	2xCH74
LCXH21A0-5	2120	1927	1413	1450	1900	45.0/2.4/47.4	2xCH74
LCXH23A0-5	2340	2127	1560	1600	2100	55.8/2.9/58.7	2xCH74
LCXH27A0-5	2700	2455	1800	1850	2450	68.4/3.4/71.8	2xCH74
LCXH31A0-5	3100	2818	2066	2150	2800	—	2xCH74

$I_{th}$  = Thermal maximum continuous RMS current. Dimensioning can be done according to this current if the process does not require any overloadability or the process does not include any torque ripple.

$I_L$  = Low overloadability current. Allows +10% torque ripple. 10% exceeding can be continuous.

$I_H$  = High overloadability current. Allows +50% torque ripple. 50% exceeding can be continuous.

All values with  $\cos\phi = 0.83$  and efficiency = 97%.

c/a/T: c = power loss into coolant; a = power loss into air; **T = total power loss**; power losses of input chokes not included. All power losses obtained using max. supply voltage and switching frequency of 3.6 kHz.

If some other mains voltage is used, apply the formula  $P = \sqrt{3} \times Un \times In \times \cos\phi$  to calculate the Liquid-Cooled drive output power.

The enclosure class for all Liquid-Cooled drives is IP00.

## DC Units

Table 1-4: Power Ratings and Dimensions of Liquid-Cooled Inverter Unit, Supply Voltage 540 – 675V DC

Catalog Number	Drive Output					Power Loss c/a/T (kW)	Chassis
	Current			Motor Output Power			
	Thermal I <sub>th</sub> (A)	Rated Cont. I <sub>L</sub> (A)	Rated Cont. I <sub>H</sub> (A)	Optimum Motor at I <sub>th</sub> 400V (kW)	Optimum Motor at I <sub>th</sub> 500V (kW)		
LCX016A0-4	16	15	11	7.5	11	0.4/0.2/0.6	CH3
LCX022A0-4	22	20	15	11	15	0.5/0.2/0.7	CH3
LCX031A0-4	31	28	21	15	18.5	0.7/0.2/0.9	CH3
LCX038A0-4	38	35	25	18.5	22	0.8/0.2/1.0	CH3
LCX045A0-4	45	41	30	22	30	1.0/0.3/1.3	CH3
LCX061A0-4	61	55	41	30	37	1.3/0.3/1.5	CH3
LCX072A0-4	72	65	48	37	45	1.2/0.3/1.5	CH4
LCX087A0-4	87	79	58	45	55	1.5/0.3/1.8	CH4
LCX105A0-4	105	95	70	55	75	1.8/0.3/2.1	CH4
LCX140A0-4	140	127	93	75	90	2.3/0.3/2.6	CH4
LCX168A0-4	168	153	112	90	110	2.5/0.3/2.8	CH5
LCX208A0-4	208	186	137	110	132	3.0/0.4/3.4	CH5
LCX261A0-4	261	237	174	132	160	4.0/0.4/4.4	CH5
LCX300A0-4	300	273	200	160	200	4.5/0.4/4.9	CH61
LCX385A0-4	385	350	257	200	250	5.5/0.5/6.0	CH61
LCX460A0-4	460	418	307	250	315	5.5/0.5/6.0	CH62
LCX520A0-4	520	473	347	250	355	6.5/0.5/7.0	CH62
LCX590A0-4	590	536	393	315	400	7.5/0.6/8.1	CH62
LCX650A0-4	650	591	433	355	450	8.5/0.6/9.1	CH62
LCX730A0-4	730	664	487	400	500	10.0/0.7/10.7	CH62
LCX820A0-4	820	745	547	450	560	12.5/0.8/13.3	CH63
LCX920A0-4	920	836	613	500	600	14.4/0.9/15.3	CH63
LCXH10A0-4	1030	936	687	560	700	16.5/1.0/17.5	CH63
LCXH11A0-4	1150	1045	766	600	750	18.4/1.1/19.5	CH63
LCXH13A0-4	1370	1245	913	700	900	15.5/1.0/16.5	CH64
LCXH16A0-4	1640	1491	1093	900	1100	19.5/1.2/20.7	CH64
LCXH20A0-4	2060	1873	1373	1100	1400	26.5/1.5/28.0	CH64
LCXH23A0-4	2300	2091	1533	1250	1500	29.6/1.7/31.3	CH64
LCXH24A0-4	2470	2245	1647	1300	1600	36.0/2.0/38.0	2*CH64
LCXH29A0-4	2950	2681	1967	1550	1950	39.0/2.4/41.4	2*CH64
LCXH37A0-4	3710	3372	2473	1950	2450	48.0/2.7/50.7	2*CH64
LCXH41A0-4	4140	3763	2760	2150	2700	53.0/3.0/66.0	2*CH64

September 2007

$I_{th}$  = Thermal maximum continuous RMS current. Dimensioning can be done according to this current if the process does not require any overloadability or the process does not include any torque ripple.

$I_L$  = Low overloadability current. Allows +10% torque ripple. 10% exceeding can be continuous.

$I_H$  = High overloadability current. Allows +50% torque ripple. 50% exceeding can be continuous.

All values with  $\cos\phi = 0.83$  and efficiency = 97%

c/a/T: c = power loss into coolant; a = power loss into air; **T = total power loss**

All power losses obtained using max. supply voltage  $I_{th}$  and switching frequency of 3.6 kHz and Closed Loop control mode. All power losses are worse case losses.

If some other mains voltage is used, apply the formula  $DC P = (Un/1.35) * \sqrt{3} * In * \cos\phi * eff\%$  to calculate the Liquid-Cooled drive electrical output power.

If the motor is continuously run (besides start and stop ramps) at frequencies below 5 Hz, pay attention to the drive dimensioning for low frequencies, i.e. maximum  $I_H = 0.66 * I_{th}$  or choose drive according to  $I_H$ . Check the rating with your Eaton distributor.

Drive overrating may also be necessary if the process requires high starting torque.

The voltage classes for the inverter units used in the tables above have been defined as follows:

*Input 540V DC = Rectified 400V AC supply*

*Input 675V DC = Rectified 500V AC supply*

The enclosure class of all inverter units is IP00.

**Table 1-5: Power Ratings and Dimensions of Liquid-Cooled Inverter Unit, Supply Voltage 710 – 930V DC**

Catalog Number	Drive Output					Power Loss c/a/T (kW)	Chassis
	Current			Motor Output Power			
	Thermal $I_{th}$ (A)	Rated Cont. $I_L$ (A)	Rated Cont. $I_H$ (A)	Optimum Motor at $I_{th}$ 710V (kW)	Optimum Motor at $I_{th}$ 930V (kW)		
LCX170A0-5	170	155	113	110	160	4.5/0.2/4.7	CH61
LCX208A0-5	208	189	139	132	200	5.5/0.3/5.8	CH61
LCX261A0-5	261	237	174	160	250	5.5/0.3/5.8	CH61
LCX325A0-5	325	295	217	200	300	6.5/0.3/6.8	CH62
LCX385A0-5	385	350	257	250	355	7.5/0.4/7.9	CH62
LCX416A0-5	416	378	277	250	355	8.0/0.4/8.4	CH62
LCX460A0-5	460	418	307	300	400	8.5/0.4/8.9	CH62
LCX502A0-5	502	456	335	355	450	10.0/0.5/10.5	CH62
LCX590A0-5	590	536	393	400	560	10.0/0.5/10.5	CH63
LCX650A0-5	650	591	433	450	600	13.5/0.7/14.2	CH63
LCX750A0-5	750	682	500	500	700	16.0/0.8/16.8	CH63
LCX820A0-5	820	745	547	560	800	16.0/0.8/16.8	CH64
LCX920A0-5	920	836	613	650	850	18.0/0.9/18.9	CH64
LCXH10A0-5	1030	936	687	700	1000	19.0/1.0/20.0	CH64
LCXH11A0-5	1180	1073	787	800	1100	21.0/1.1/22.1	CH64
LCXH13A0-5	1300	1182	867	900	1200	27.0/1.4/28.4	CH64
LCXH15A0-5	1500	1364	1000	1050	1400	32.0/1.6/33.6	CH64
LCXH17A0-5	1700	1545 <sup>Ⓢ</sup>	1133 <sup>Ⓢ</sup>	1150	1550	NA	CH64
LCXH18A0-5	1850	1682	1233	1250	1650	34.2/1.8/36.0	2*CH64
LCXH21A0-5	2120	1927	1413	1450	1900	37.8/2.0/39.8	2*CH64
LCXH23A0-5	2340	2127	1560	1600	2100	48.6/2.5/51.1	2*CH64
LCXH27A0-5	2700	2455	1800	1850	2450	57.6/3.0/60.6	2*CH64
LCXH31A0-5	3100	2818 <sup>Ⓢ</sup>	2066 <sup>Ⓢ</sup>	2150	2800	NA	2*CH64

<sup>Ⓢ</sup> Calculated

$I_{th}$  = Thermal maximum continuous RMS current. Dimensioning can be done according to this current if the process does not require any overloadability or the process does not include any torque ripple.

$I_L$  = Low overloadability current. Allows +10% torque ripple. 10% exceeding can be continuous.

$I_H$  = High overloadability current. Allows +50% torque ripple. 50% exceeding can be continuous.

All values with  $\cos\phi = 0.83$  and efficiency = 97%

c/a/T: c = power loss into coolant; a = power loss into air; **T = total power loss**

All power losses obtained using max. supply voltage  $I_{th}$  and switching frequency of 3.6 kHz and Closed Loop control mode. All power losses are worse case losses.

If some other mains voltage is used, apply the formula  $DC P = (Un/1.35) * \sqrt{3} * In * \cos\phi * eff\%$  to calculate the Liquid-Cooled drive electrical output power.



September 2007

If the motor is continuously run (besides start and stop ramps) at frequencies below 5 Hz, pay attention to the drive dimensioning for low frequencies, i.e. maximum  $I_L = 0.66 * I_{th}$  or choose drive according to  $I_H$ . Check the rating with your Eaton distributor.

Drive overrating may also be necessary if the process requires high starting torque.

The voltage classes for the inverter units used in the tables above have been defined as follows:

*Input 710V DC = Rectified 525V AC supply*

*Input 930V DC = Rectified 690V AC supply*

The enclosure class of all inverter units is IP00.

## Specifications

**Table 1-6: Technical Information**

Description	Specification
<b>Mains Connection</b>	
Input voltage $U_{in}$	400 – 500V AC; 525 – 690V AC; (-10% – 10%) 465 – 800V DC; 640 – 1100V DC; (-0% – 0%)
Input frequency	45 – 66 Hz
Connection to mains	Once per minute or less
<b>Motor Connection</b>	
Output voltage	0 – $U_{in}$
Continuous output current	Rated current at nominal inflow cooling water temperature according to dimensioning charts
Output frequency	0 – 320 Hz (standard); 7200 Hz (Special software)
Frequency resolution	Application dependent
<b>Control Characteristics</b>	
Control method	Frequency control U/f Open Loop Sensorless Vector Control Closed Loop Vector Control
Switching frequency (see parameter 2.6.9)	<b>480V:</b> Up to and including 61 Amp Size: 1 – 16 kHz; Factory default 10 kHz From 72 Amp Size: 1 – 12 kHz; Factory default 3.6 kHz <b>575V:</b> 1 – 6 kHz; Factory default 1.5 kHz <b>Note: Derating required if higher switching frequency than the default is used!</b>
Frequency reference Analog input Panel reference	Resolution 0.1% (10-bit), accuracy $\pm 1\%$ Resolution 0.01 Hz
Field weakening point	8 – 320 Hz
Acceleration time	.1 – 3000 sec
Deceleration time	.1 – 3000 sec
Braking torque	DC brake: 30% * $T_N$ (without brake option)
<b>Ambient Conditions</b>	
Ambient operating temperature	14°F (-10°C) (no frost) to +122°F (+50°C) (at $I_{th}$ ) 122 – 158°F (50 to 70°C) derating required, see <b>Pages 2-17 and 2-23</b>
Storage temperature	-40 to +158°F (-40 to +70°C); No liquid in heatsink under 32°F (0°C)
Relative humidity	5 to 96% RH, non-condensing, no dripping water
Air quality: chemical vapors mechanical particles	IEC 721-3-3, unit in operation, class 3C2 IEC 721-3-3, unit in operation, class 3S2 (no conductive dust allowed) No corrosive gases
Altitude	100% load capacity (no derating) up to 1,000m; above 1,000m derating of 1% per each 100m required
Vibration EN50178/EN60068-2-6	5 – 150 Hz Displacement amplitude 25 mm (peak) at 3 – 31 Hz Max acceleration amplitude 1 G at 31 – 150 Hz
Shock EN50178, EN60068-2-27	UPS Drop Test (for applicable UPS weights) Storage and shipping: max 15G, 11 mS (in package)
Enclosure class	IP00/Open Frame standard in entire kW/hp range

September 2007

**Table 1-6: Technical Information (Continued)**

Description	Specification
<b>EMC</b>	
Immunity	Fulfills all EMC immunity requirements
Emissions	EMC level N; EMC level T for IT networks
<b>Safety</b>	
Approvals	EN50178, EN60204-1, CE, UL, CUL, FI, GOST R, (see unit nameplate for more detailed approvals)
Safe disable board	The drive is equipped with OPTAF board for prevention of torque on motor shaft. Standards: EN954-1, cat. 3 (hardware disable); BGIA (Safe Disable Function).
<b>Control connections (apply to boards OPT-A1, OPT-A2 and OPT-A3)</b>	
Analog input voltage	0 to +10V, $R_i = 200k\Omega$ , (-10V to +10V joystick control) Resolution 0.1%, accuracy $\pm 1\%$
Analog input current	0(4) – 20 mA, $R_i = 250\Omega$ differential
Digital inputs (6)	Positive or negative logic; 18 – 24V DC
Auxiliary voltage	+24V, $\pm 10\%$ , max volt. ripple <100 mVrms; max. 250 mA Dimensioning: max. 1000 mA/control box 1A external fuse required (no internal short-circuit protection on the control board)
Output reference voltage	+10V, +3%, max. load 10 mA
Analog output	0(4) – 20 mA; $R_L$ max. 500 $\Omega$ ; Resolution 10 bit; Accuracy $\pm 2\%$
Digital outputs	Open collector output, 50 mA/48V
Relay outputs	2 programmable change-over relay outputs Switching capacity: 24V DC/8A, 250V AC/8A, 125V DC/.4A Min. switching load: 5V/10 mA
<b>Protections</b>	
Overvoltage trip limit	<b>480V:</b> 911V; <b>575V:</b> 1200V (all VDC)
Undervoltage trip limit	<b>480V:</b> 333V; <b>575V:</b> 461V (all VDC)
Ground fault protection	In case of ground fault in motor or motor cable, only the drive is protected
Mains supervision	Trips if any of the input phases is missing
Motor phase supervision	Trips if any of the output phases is missing
Unit overtemperature protection	Alarm limit: 149°F (65°C) (heatsink); 158°F (70°C) (circuit boards) Trip limit: 158°F (70°C) (heatsink); 185°F (85°C) (circuit boards)
Overcurrent protection	Yes
Motor overload protection	Yes
Motor stall protection	Yes
Motor underload protection	Yes
Short-circuit protection of +24V and +10V reference voltages	Yes
<b>Liquid Cooling</b>	
Allowed cooling agents	Drinking water (see specification on <b>Page 2-11</b> ) Water-glycol mixture See derating specifications on <b>Page 2-23</b>
Volume	See <b>Page 2-15</b> .
Temperature of cooling agent	32 – 86°F (0 – 30°C) ( $t_{th}$ )(input); 86 – 149°F (30 – 65°C): derating required, see <b>Page 2-23</b> . Max. temperature rise during circulation max. 41°F (5°C) No condensation allowed. See <b>Pages 2-17</b> .
Cooling agent flow rates	See <b>Table 2-7</b> .
System max. working pressure	87 psi
System max. peak pressure	580 psi
Pressure loss (at nominal flow)	Varies according to size. See <b>Table 2-10</b> .



September 2007

## Chapter 2 — Installation

### Mounting

Liquid-cooled drive modules must be installed into an enclosure. The drives consisting of one module will be mounted on the mounting plate. The drives that include two or three modules are mounted inside a mounting bracket, which will then be installed in the enclosure.

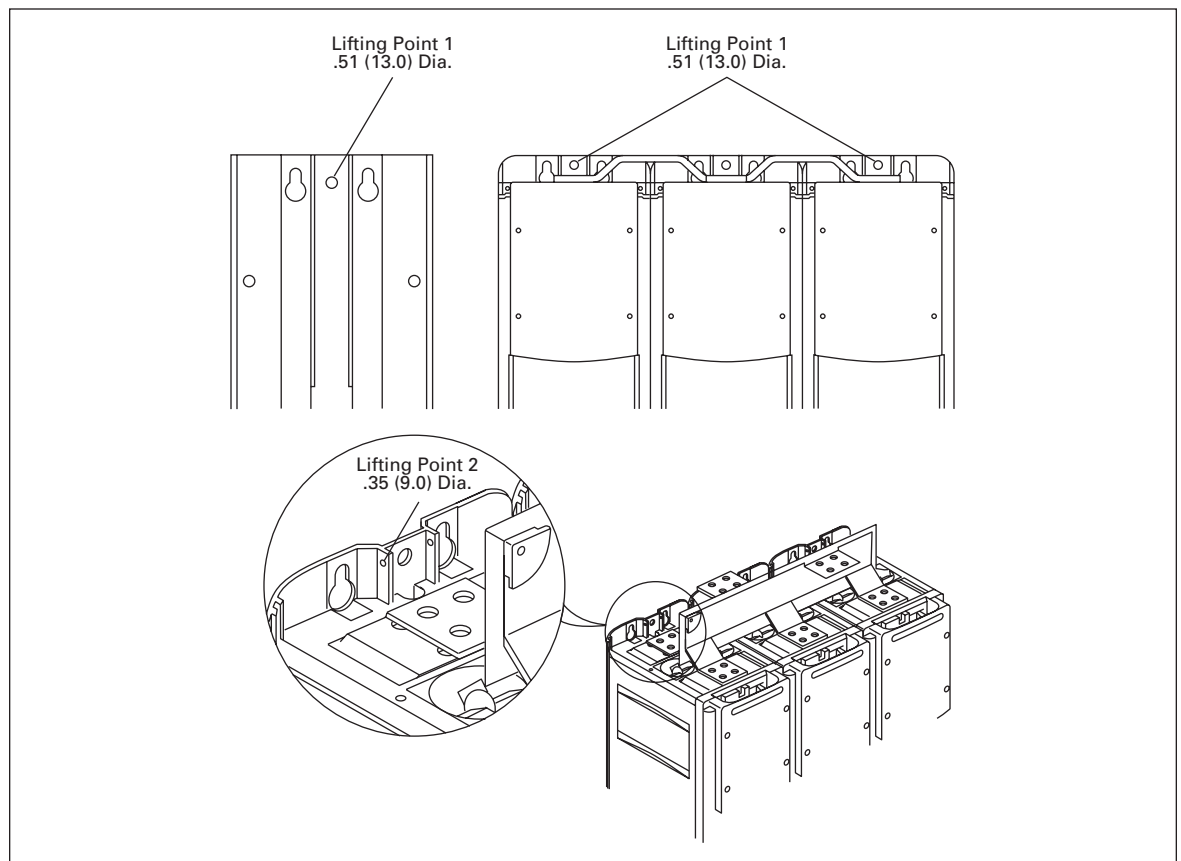
**Note:** If any other than vertical installation position is required, please contact your distributor!

On **Page 2-2** you will find the dimensions of liquid-cooled drives installed on mounting bases (plates and brackets).

#### Lifting the Drive

Eaton recommends use of a jib crane or similar elevating device to lift the drive unit. See **Figure 2-1** for correct lifting points.

Use either the hole(s) in the middle of the mounting plate (Lifting point 1) or the hole in the H-shaped part of the mounting plate (Lifting point 2) for lifting the drive. See **Figure 2-1**.



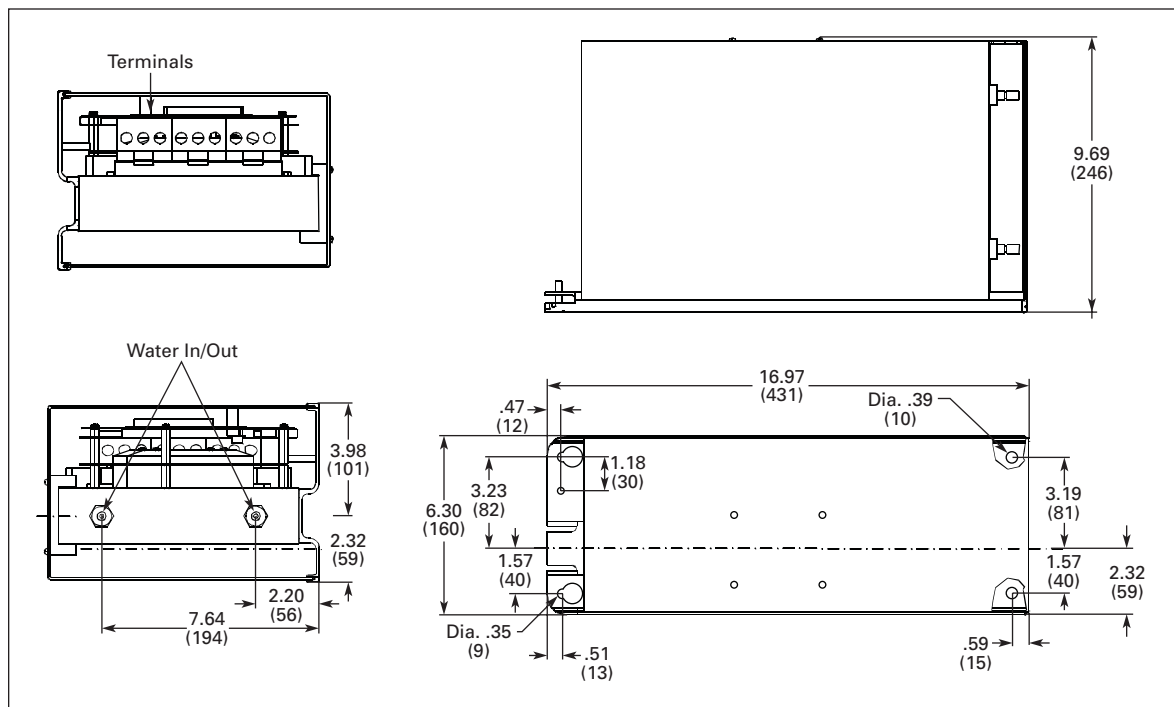
**Figure 2-1: Lifting Points for Drives Consisting of One Module (Left) and Several Modules**  
*Approximate Dimensions in Inches (mm)*

**Liquid-Cooled Dimensions**

**Drives Consisting of One Module**

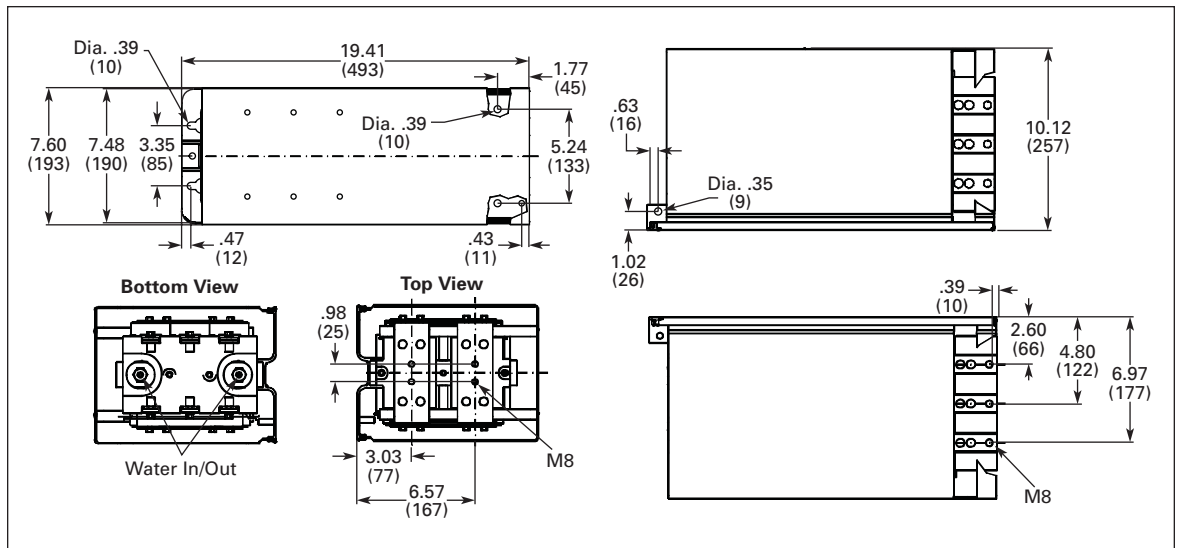
**Table 2-1: One-Module Drive Dimensions (Mounting Base Included)**

Chassis	Approximate Dimensions in Inches (mm)			Weight in Lbs. (kg)
	Width	Height	Depth	
CH3	6.30 (160)	16.97 (431)	9.69 (246)	66 (30)
CH4	7.60 (193)	19.41 (493)	10.12 (257)	77 (35)
CH5	9.69 (246)	21.77 (553)	10.39 (264)	88 (40)
CH61/62	9.69 (246)	25.91 (658)	14.65 (372)	121 (55)
CH72	9.69 (246)	42.36 (1076)	14.65 (372)	198 (90)

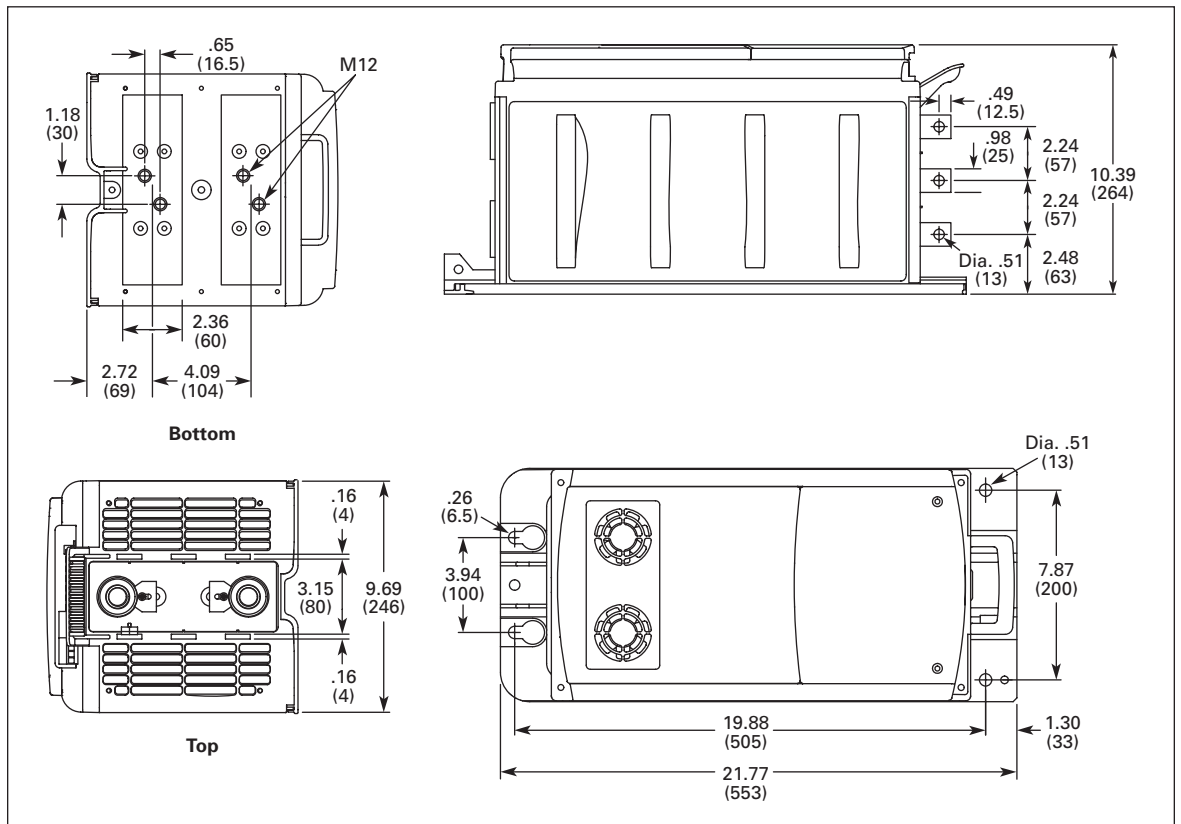


**Figure 2-2: LCX9000 Liquid-Cooled Drive, CH3**  
*Approximate Dimensions in Inches (mm)*

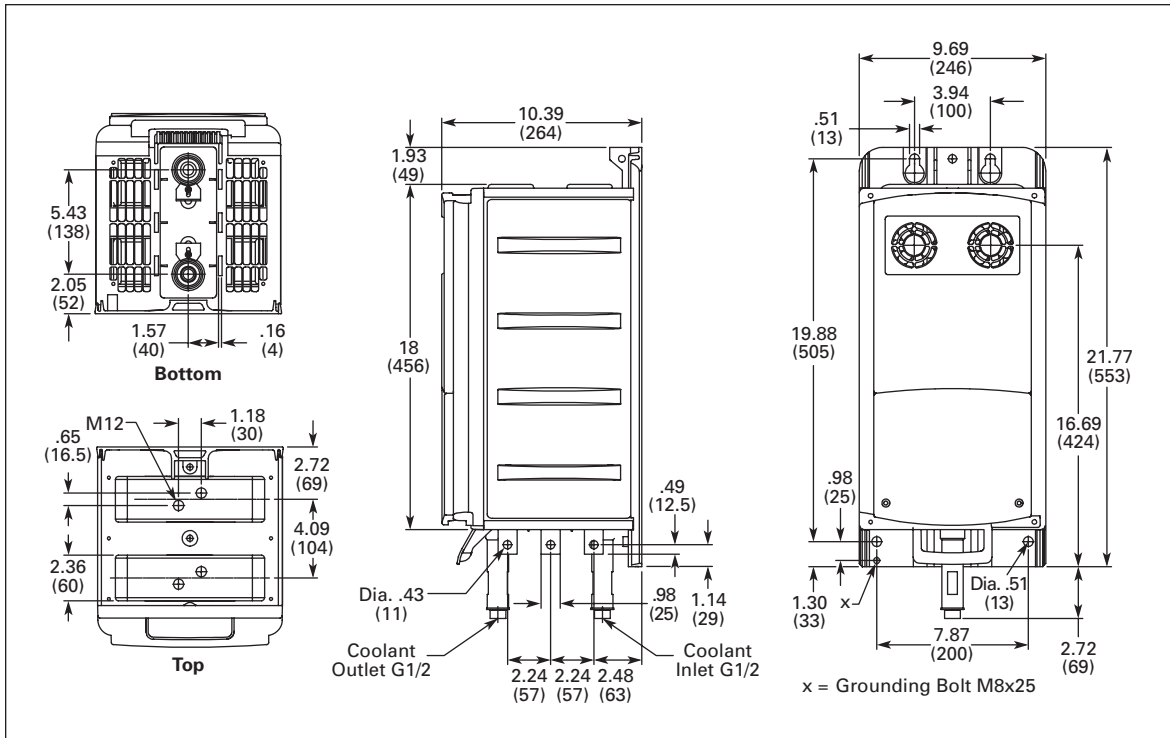
September 2007



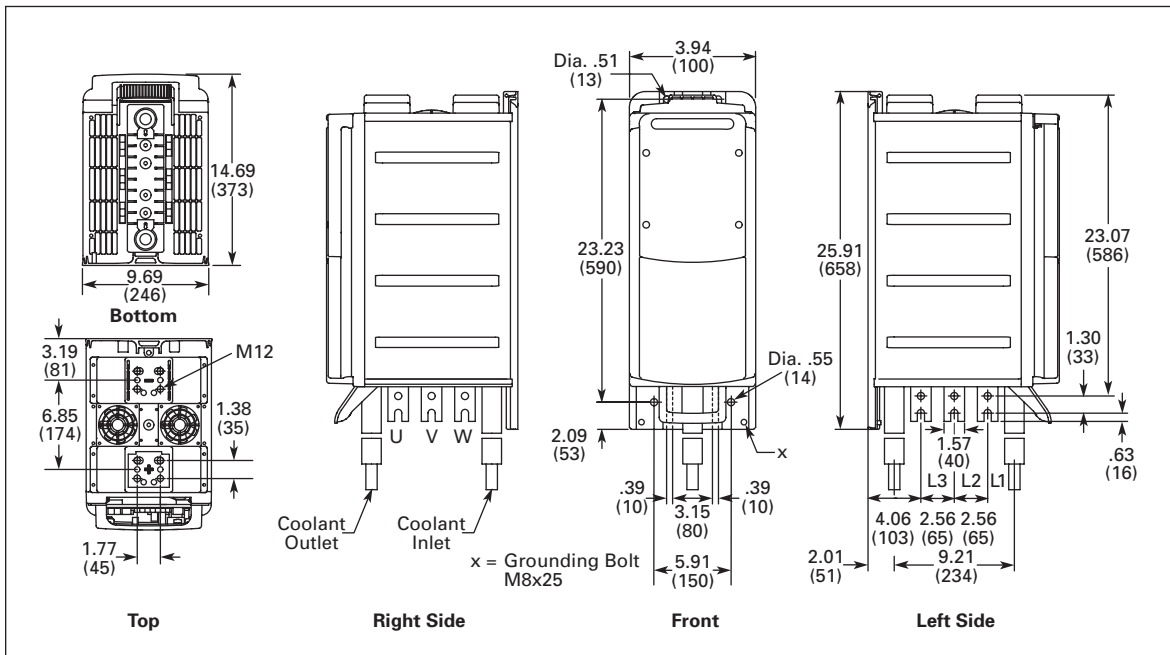
**Figure 2-3: LCX9000 Liquid-Cooled Drive, CH4**  
*Approximate Dimensions in Inches (mm)*



**Figure 2-4: LCX9000 Liquid-Cooled Drive, CH5**  
*Approximate Dimensions in Inches (mm)*



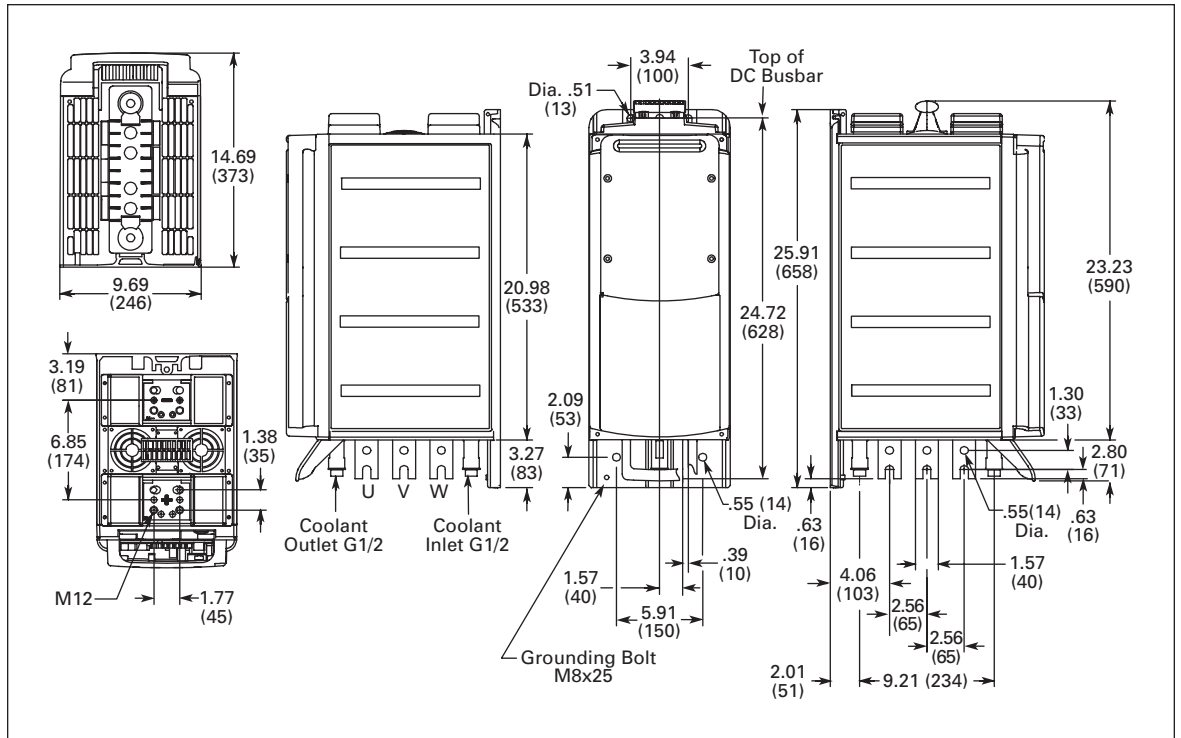
**Figure 2-5: LCX9000 Liquid-Cooled Inverter, CH5**  
*Approximate Dimensions in Inches (mm)*



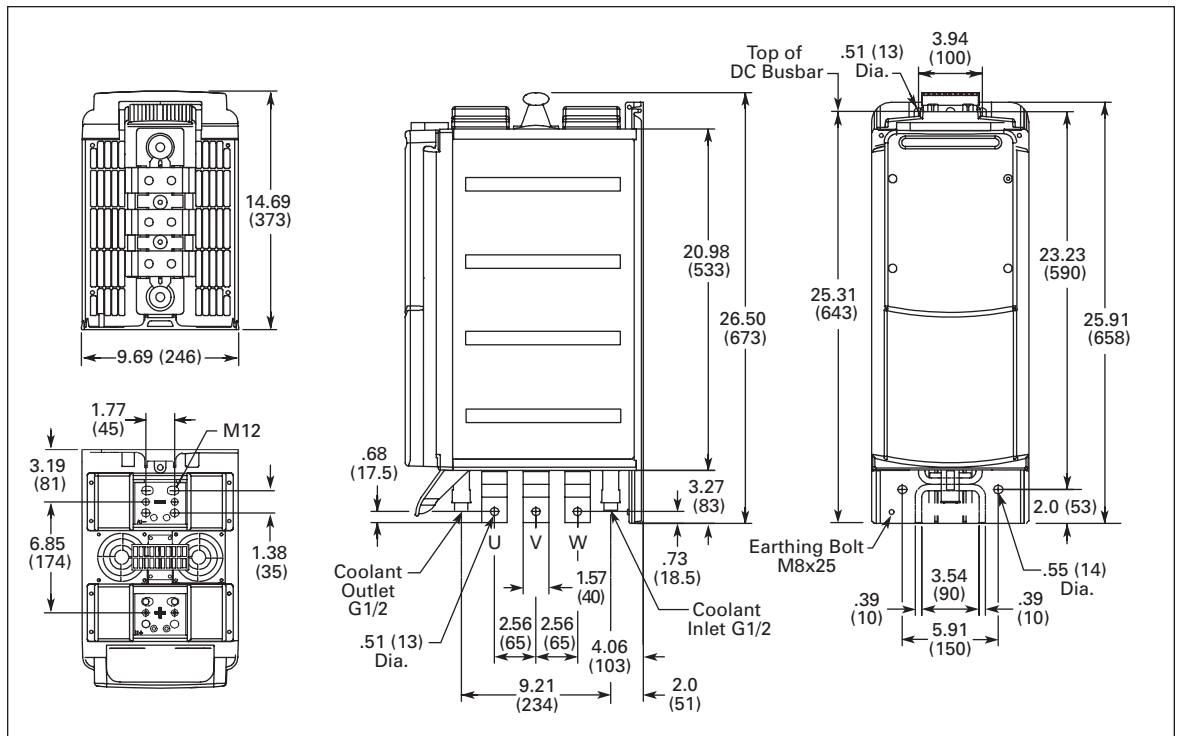
**Figure 2-6: LCX9000 Liquid-Cooled Drive, CH61**  
*Approximate Dimensions in Inches (mm)*



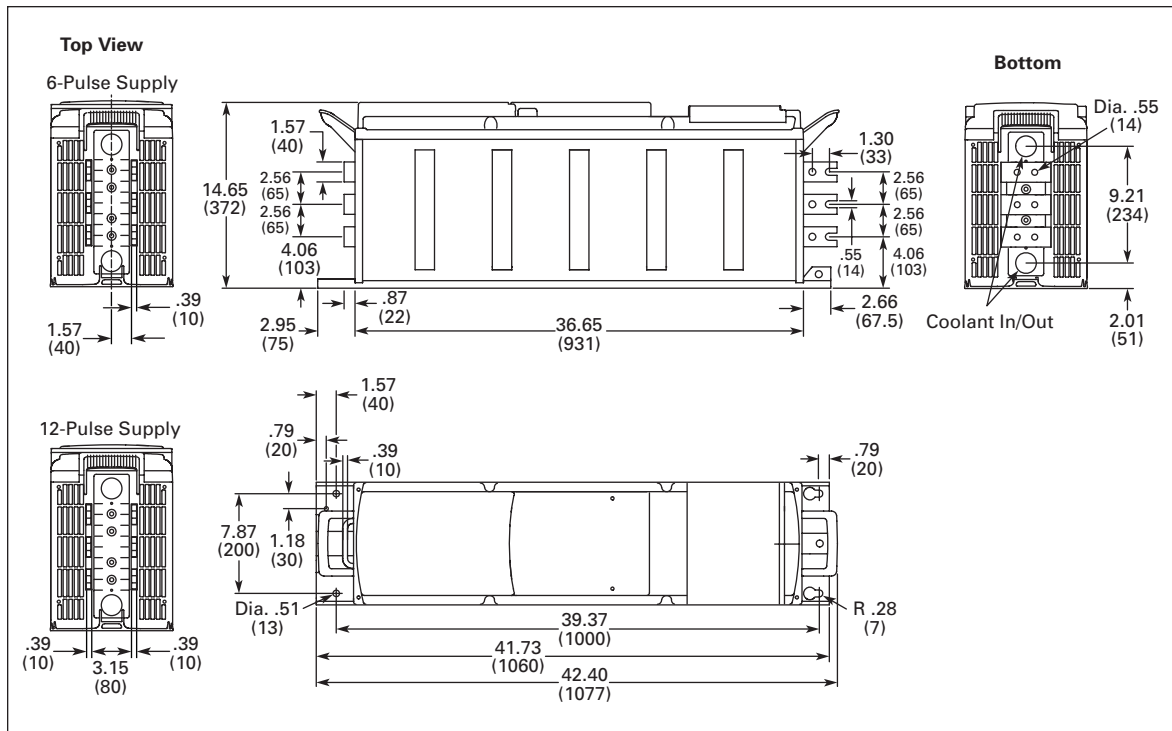
September 2007



**Figure 2-7: LCX9000 Liquid-Cooled Inverter, CH61**  
*Approximate Dimensions in Inches (mm)*



**Figure 2-8: LCX9000 Liquid-Cooled Inverter, CH62**  
*Approximate Dimensions in Inches (mm)*

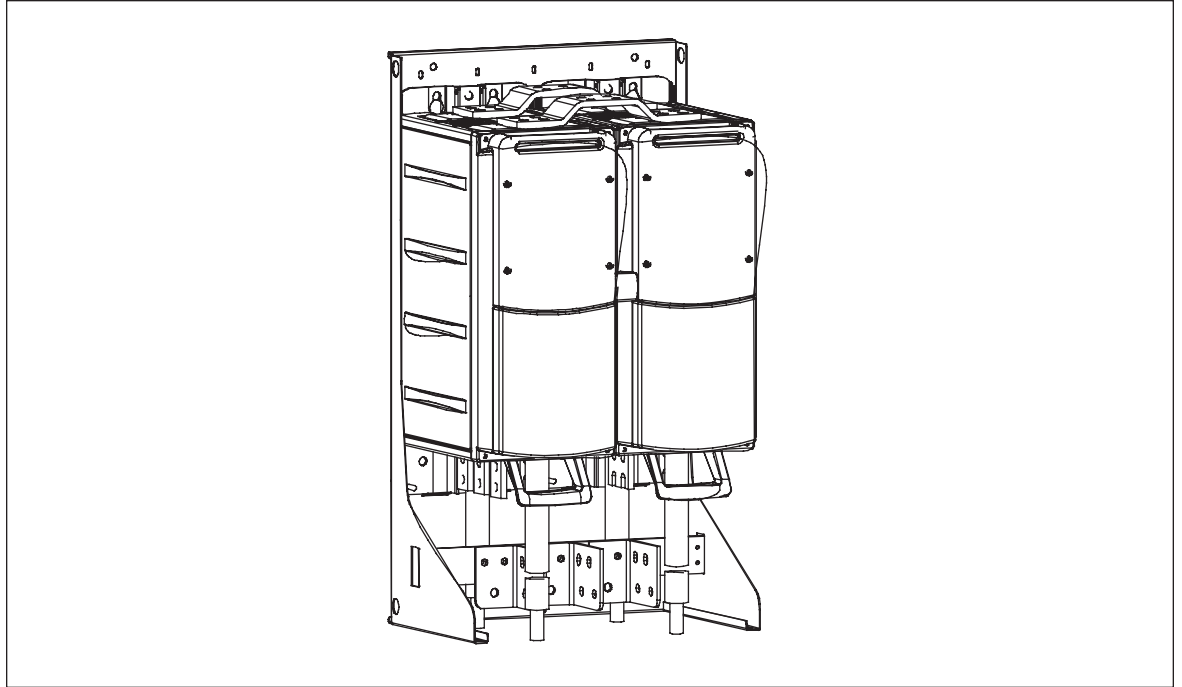


**Figure 2-9: LCX9000 Liquid-Cooled Drive, CH72**  
*Approximate Dimensions in Inches (mm)*

September 2007

**Drives Consisting of Several Modules**

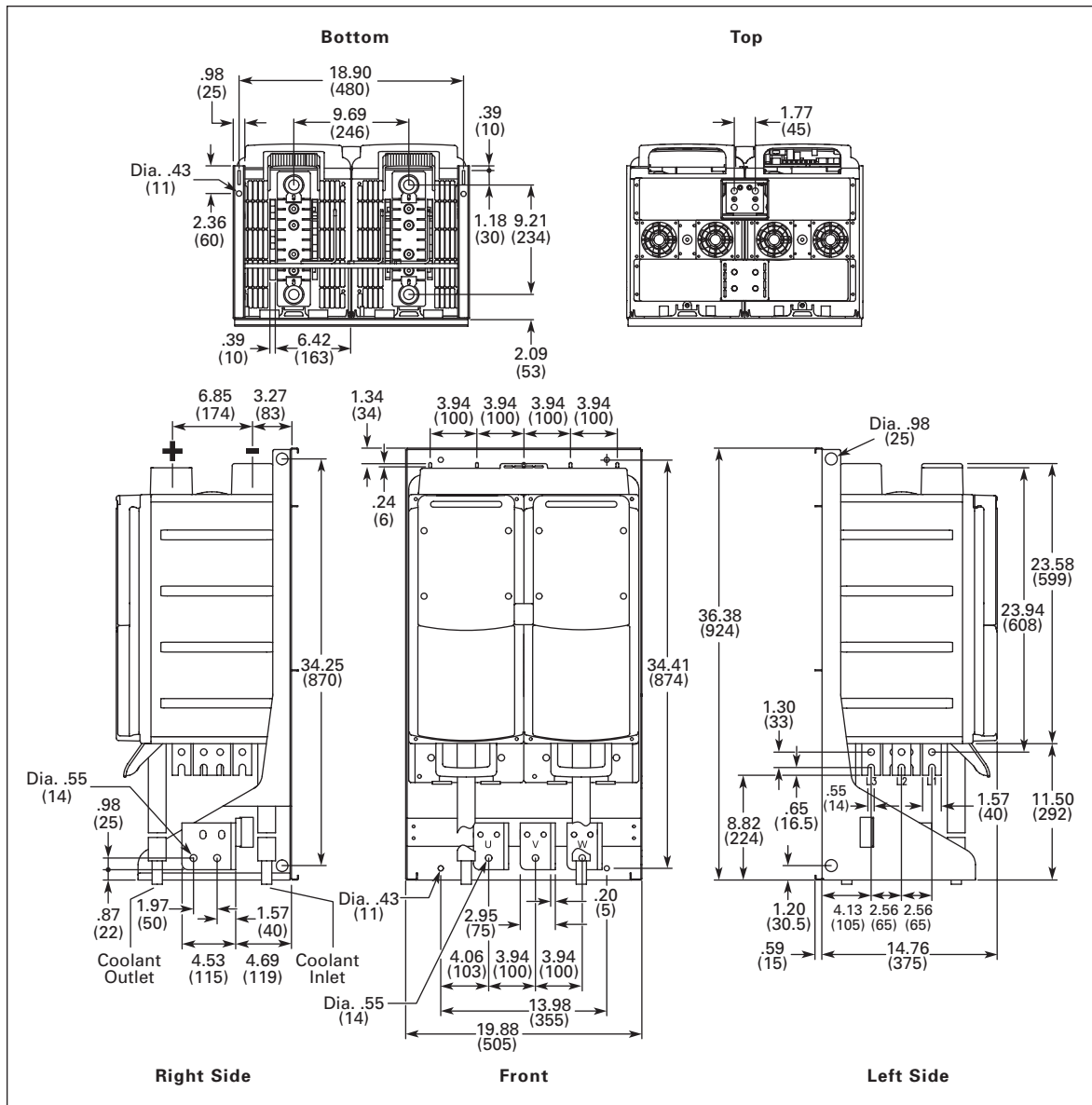
Liquid-cooled drives consisting of several modules are mounted in a mounting bracket as presented in **Figure 2-10**.



**Figure 2-10: Drive Mounted Inside Mounting Bracket**

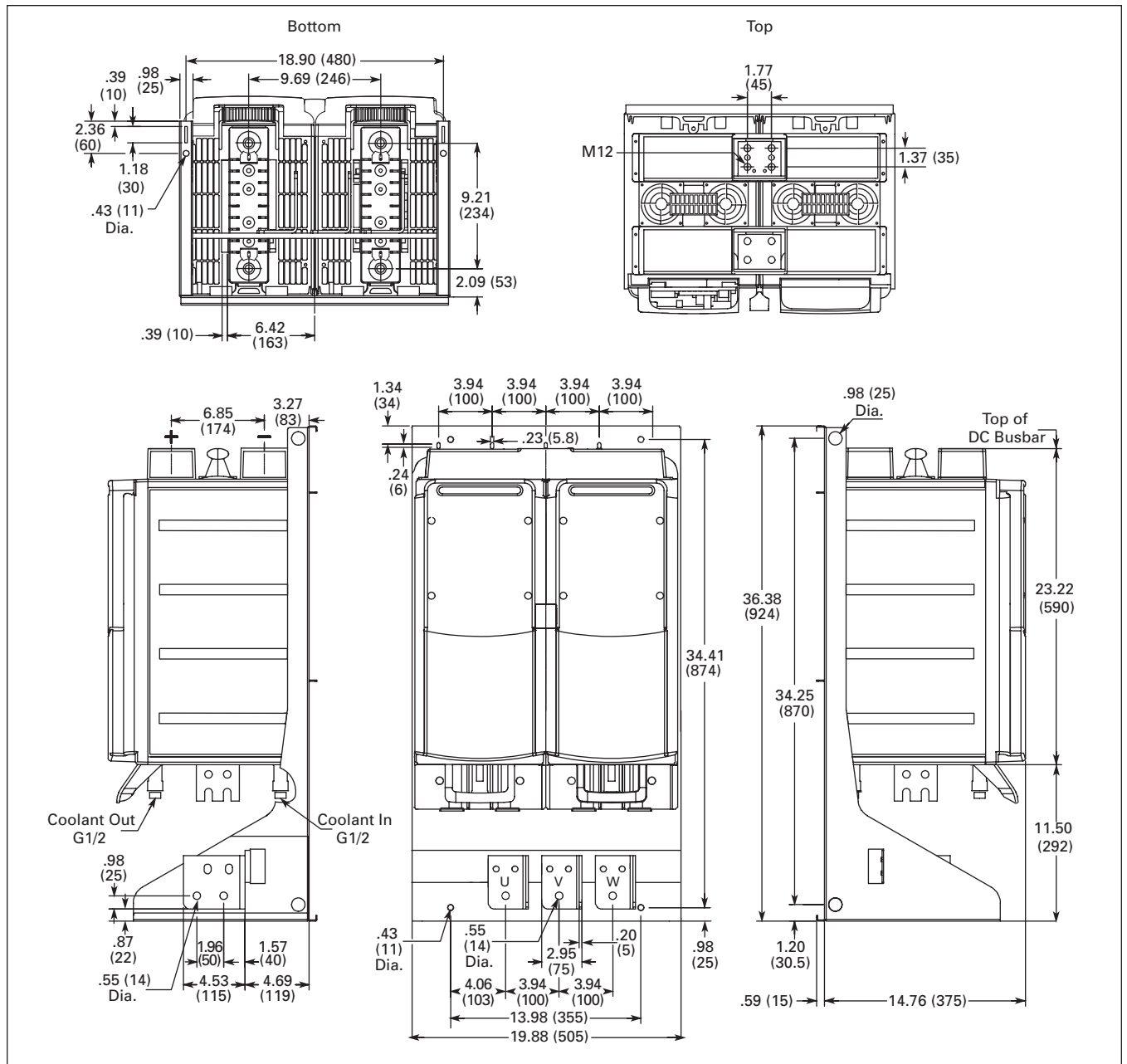
**Table 2-2: Several Module Drive Dimensions (Mounting Bracket Included)**

Chassis	Approximate Dimensions in Inches (mm)			Weight in Lbs. (kg)
	Width	Height	Depth	
CH63	19.88 (505)	36.38 (924)	14.76 (375)	264 (120)
CH64	29.37 (746)	36.38 (924)	14.76 (375)	396 (180)
CH74	29.37 (746)	46.26 (1175)	15.16 (385)	617 (280)

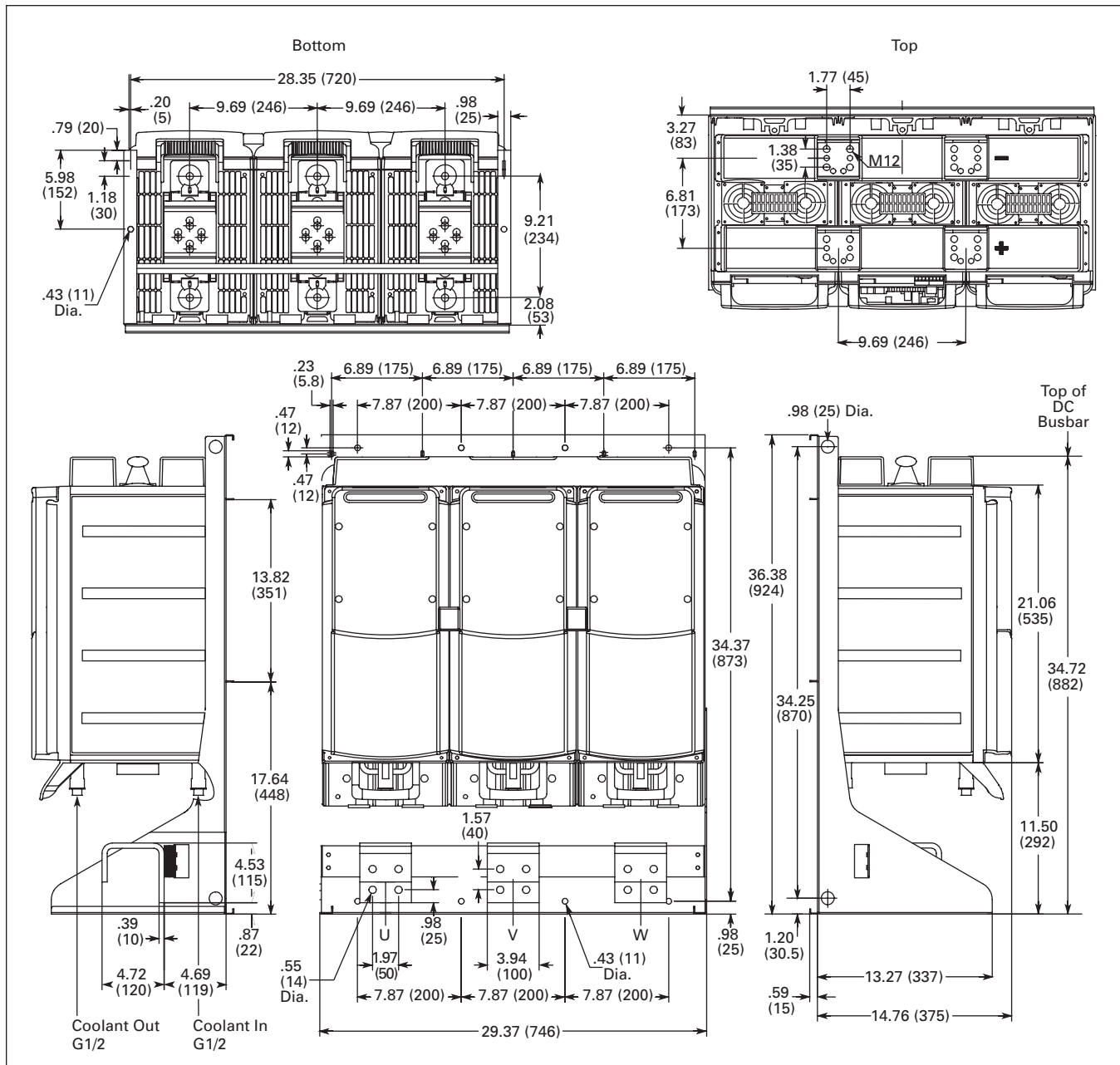


**Figure 2-11: LCX9000 Liquid-Cooled Drive with Mounting Bracket, CH63**  
*Approximate Dimensions in Inches (mm)*

September 2007

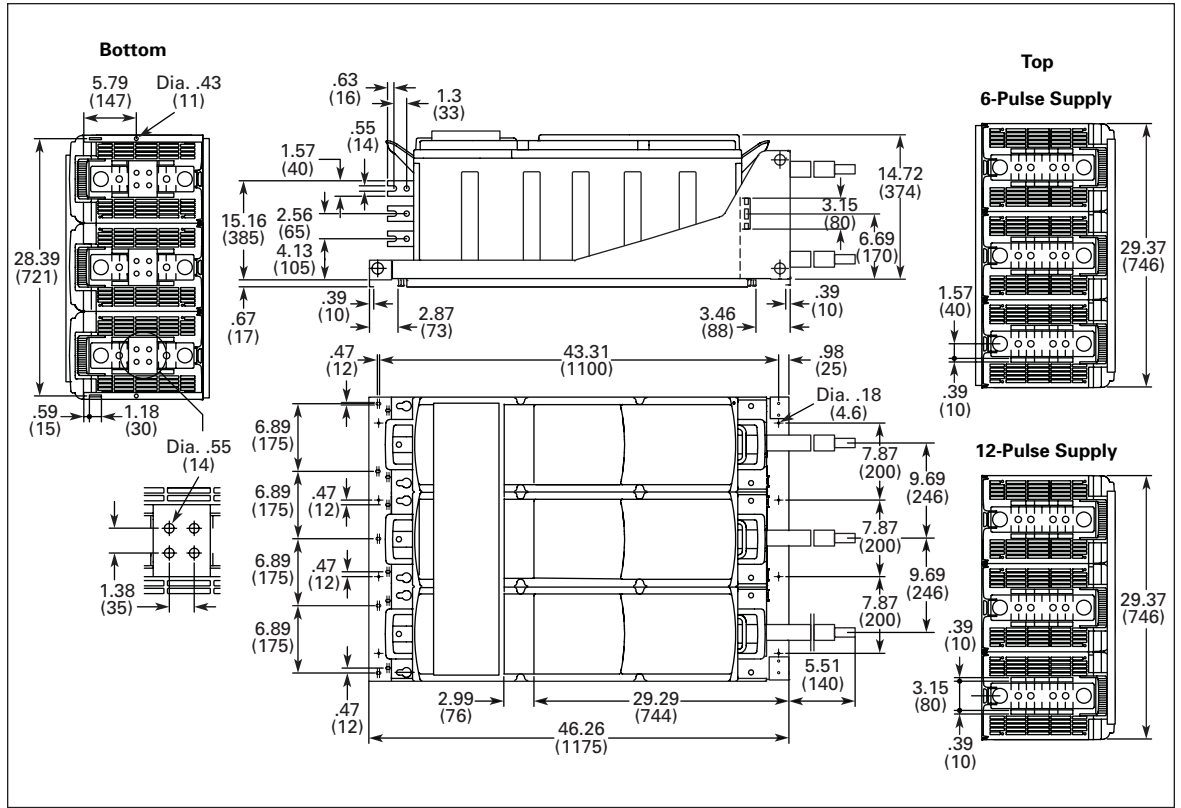


**Figure 2-12: LCX9000 Liquid-Cooled Inverter with Mounting Bracket, CH63**  
*Approximate Dimensions in Inches (mm)*



**Figure 2-13: LCX9000 Liquid-Cooled Inverter with Mounting Bracket, CH64, IP90**  
*Approximate Dimensions in Inches (mm)*

September 2007



**Figure 2-14: LCX9000 Liquid-Cooled Drive, CH74, IP00**  
*Approximate Dimensions in Inches (mm)*

## Cooling

Instead of using air for cooling, Cutler-Hammer Liquid-Cooled drives are cooled with liquid. The liquid circulation of the drive is usually connected to a heat-exchanger (liquid-liquid/liquid-air) which cools down the liquid circulating in the cooling elements of the drive. The cooling agents acceptable for use are drinking water, demineralized water or a mixture (60/40) of water and glycol. In a closed circulation system, the values in **Table 2-3** are recommended reference values. To avoid electrochemical corrosion, Eaton recommends adding an inhibitor (e.g. Ferrolix 332/Henkel or Cortec VpCI-649) in the cooling agent.

**Note:** If no heat-exchanger is used, actions must be taken to avoid electrochemical corrosion. Specifically no brass or copper elements may be used in the liquid circulation of the drive.

### Drinking Water Specification

**Table 2-3** provides general guidelines for water quality.

**Note:** 1 mg/L = 1 ppm.

**Table 2-3: Drinking Water Chemical Specification**

Quality	Unit	Value	Quality	Unit	Value
Acrylamide	µg/L	0.10	Mercury	µg/L	1.0
Antimony	µg/L	5.0	Nickel	µg/L	20
Arsenic	µg/L	10	Nitrate [NO <sub>3</sub> ]	mg/L	50
Benzene	µg/L	1.0	Nitrate-Nitrogen [NO <sub>3</sub> -N]	mg/L	11.0
Benzopyrene	µg/L	0.010	Nitrite [NO <sub>2</sub> ]	mg/L	0.5
Boron	mg/L	1.0	Nitrite-Nitrogen [NO <sub>2</sub> -N]	mg/L	0.15
Bromate	µg/L	10	Bactericides	µg/L	0.10
Cadmium	µg/L	5.0	Bactericides, total	µg/L	0.50
Chromium	µg/L	50	Polynuclear aromatic hydrocarbons	µg/L	0.10
Copper	mg/L	2.0	Selenium	µg/L	10
Cyanides	µg/L	50	Tetrachloroethylene and trichloroethylene total	µg/L	10
1,2-Dichloroethane	µg/L	3.0	Trihalomethanes total	µg/L	100
Epichlorohydrin	µg/L	0.10	Vinyl chloride	µg/L	0.50
Fluoride	mg/L	1.5	Chlorophenols total	µg/L	10
Lead	µg/L	10			

**Table 2-4: Drinking Water Quality Recommendations — Maximum Values**

Quality	Unit	Max. Value
Aluminum	µg/L	200
Ammonium [NH <sub>2</sub> ]	mg/L	0.50
Ammonium [NH <sub>2</sub> -N]	mg/L	0.40
Chloride <sup>①</sup>	mg/L	<100
Manganese	µg/L	50
Iron	µg/L	<0.5
Sulphate <sup>①②</sup>	mg/L	250
Sodium	mg/L	200
Oxidizability [COD <sub>Mn</sub> -O <sub>2</sub> ]	mg/L	5.0

<sup>①</sup> No aggressive water allowed.

<sup>②</sup> To avoid corrosion of piping, the sulphate content must not exceed 150 mg/L.



September 2007

**Table 2-5: Drinking Water Quality Recommendations — Desired Values**

Quality	Unit	Desired Value
Clostridium perfringens (including spores)	pmy/100 ml	0
Coliform bacteria	pmy/100 ml	0
Bacterial count [22°C]	—	No unusual changes
pH <sup>①</sup>	pH	6 – 8
Electrical conductivity <sup>①</sup>	μS/cm	<100
Turbidity	—	<sup>②</sup>
Color	—	No unusual changes
Smell and taste	—	No unusual changes
Total organic carbon (TOC)	—	No unusual changes
Tritium	beg/L	100
Indicative total dose	mSv/year	0.10
Water hardness	°dH	3 – 10
Max. particle size in coolant	μm	300

<sup>①</sup> No aggressive water allowed.

<sup>②</sup> To be approved by user and no unusual changes.

The cleanness of the heat exchanger, and therefore the heat exchanging capacity, depend on the purity of the process water. The more impure the water, the more frequently the heat exchanger needs cleaning. The values in **Table 2-6** are reference values required of cooling circuit process water.

**Table 2-6: Process Water Specification**

Quality	Unit	Value
pH	pH	6 – 9
Water Hardness	°dH	<20
Electrical Conductivity	μS/cm	<100
Chlorides (Cl)	mg/L	<100
Iron (Fe)	mg/L	<.5

The design temperature of the cooling agent entering the drive module(s) is 95°F (35°C). While circulating inside the cooling element, the liquid transfers the heat produced by the power semiconductors (and the capacitors). The design temperature rise of the cooling agent during the circulation is less than 9°F (5°C). Typically, 95% of the power losses is dissipated in the liquid. Eaton recommends equipping the cooling agent circulation with temperature supervision.

The heat exchanging equipment can be located outside the electrical room in which the drives are located. The connections are made on site. In order to minimize the pressure drops, the pipings should be made as straight as possible. We further recommend mounting a regulating valve equipped with a measurement point. This makes the measurement and regulation of liquid circulation possible in the start-up phase.

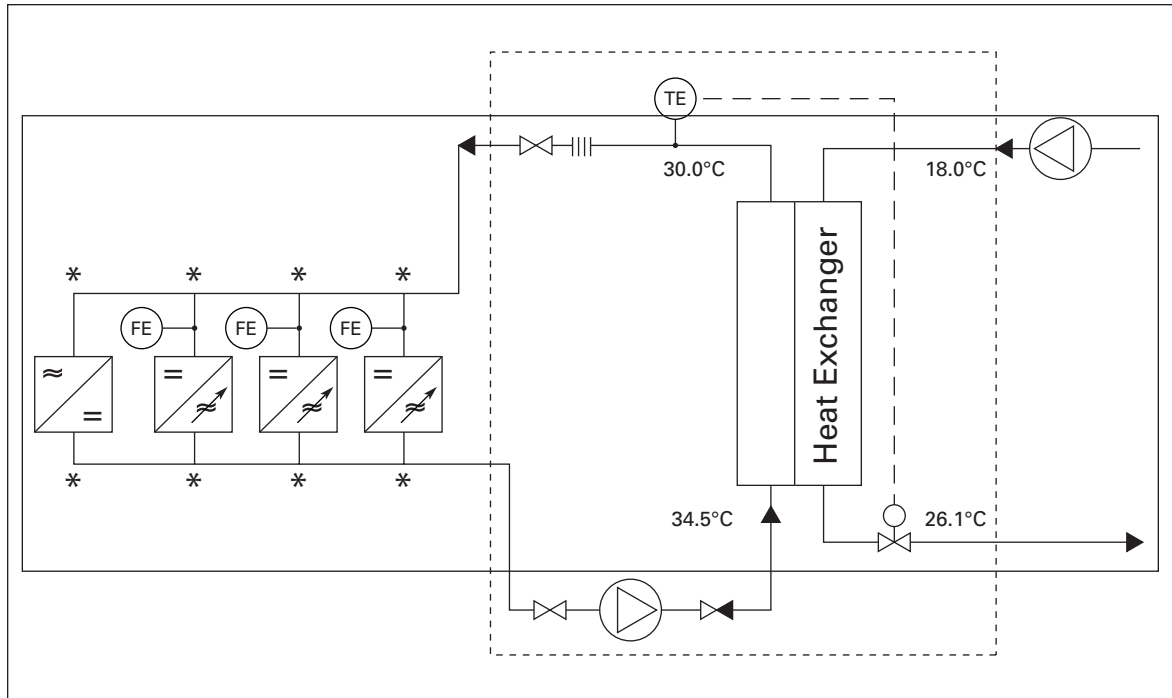
In order to prevent dirt particles from accumulating in the connections and gradually weakening the cooling effect, installation of filters is also recommended.

The highest point of the piping must be equipped with either an automatic or a manual venting device. The material of the piping must comply with at least AISI 304 (AISI 316 is recommended).

Prior to the actual connection of the pipes, the bores must be cleaned thoroughly. If cleaning with water is not possible, pressured air must be used to remove all loose particles and dust.

To facilitate the cleaning and venting of the coolant circulation, installation of a bypass valve in the main line and valves at each drive inlet is recommended. Open the bypass valve and shut the valves to the drive when cleaning and airing the system. At start-up, the bypass valve must be closed and the valves to the converters opened.

**Figure 2-15** shows a simplified example of the cooling system as well as an example of the connections between the drives and the cooling system.

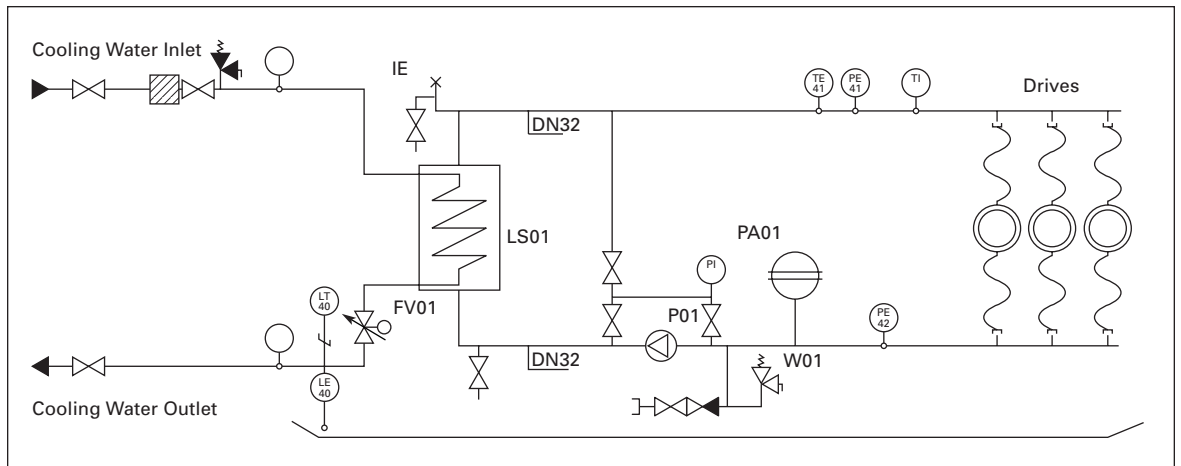


**Figure 2-15: Example of Cooling System**

Eaton recommends equipping the cooling system with pressure and flow supervision (FE). The flow supervision can be connected to digital input function External fault. If the coolant flow becomes too low, the drive will be stopped.

The flow supervision and other actuators, e.g. a constant flow valve, are available as options. The options should be mounted at the junction of the main line and the branching line to the element, indicated with an asterisk (\*) in **Figure 2-15**.

September 2007



**Figure 2-16: Example PI-Diagram of Cooling System and Connections**

**Table 2-7** shows the specifications related to the cooling agent and its circulation. Also see **Table 1-6**, Technical Information on **Page 1-14**.

**Table 2-7: Information About Cooling Agent and Its Circulation**

Chassis	Min. Liquid Flow per Element (Drive) in GPM	Nom. Liquid Flow per Element (Drive) in GPM			Max. Liquid Flow per Element (Drive) in GPM
	A	A	B	C	A
CH3	.8 (.8)	1.3 (1.3)	1.4 (1.4)	1.5 (1.5)	5.3 (5.3)
CH4	2.1 (2.1)	2.6 (2.6)	2.9 (2.9)	3.2 (3.2)	5.3 (5.3)
CH5	2.6 (2.6)	4.0 (4.0)	4.2 (4.2)	4.5 (4.5)	10.6 (10.6)
CH61	5.3 (5.3)	6.6 (6.6)	7.1 (7.1)	7.7 (7.7)	10.6 (10.6)
CH62	5.3 (5.3)	6.6 (6.6)	7.1 (7.1)	7.7 (7.7)	10.6 (10.6)
CH63	5.3 (10.6)	6.6 (13.2)	7.1 (14.3)	7.7 (15.3)	10.6 (21.1)
CH64	5.3 (15.9)	6.6 (19.8)	7.1 (21.1)	7.7 (22.7)	10.6 (31.7)
CH72	5.3 (5.3)	9.2 (9.2)	9.8 (9.8)	10.6 (10.6)	10.6 (10.6)
CH74	5.3 (15.9)	9.2 (26.4)	9.8 (29.6)	10.3 (32.0)	10.6 (31.7)

**A** = 100% water; **B** = Water/Glycol mixture 80:20; **C** = Water/Glycol mixture (60:40)

Definitions: **Min. liquid flow** = Minimum flow rate to ensure of total venting of the cooling element

**Nom. liquid flow** = Flow rate while running the drive at  $I_{th}$

**Max. liquid flow** = If flow rate exceeds max. liquid flow, risk of cooling element erosion increases

**Note:** Unless minimum liquid flow rate is ensured, air pockets may develop in the cooling elements.

**Table 2-8** will help you to determine the appropriate flows of cooling agent (GPM) with given power losses (see **Page 1-7**).

**Table 2-8: Cooling Agent Flow Rates (GPM) in Relation to Power Loss at Certain Glycol/Water Mixture**

Power Loss (kW)	Glycol:Water Ratio					
	100:0	80:20	60:40	40:60	20:80	0:100
1	1.16	1.04	0.95	0.87	0.81	0.76
2	2.33	2.08	1.89	1.74	1.62	1.52
3	3.49	3.12	2.83	2.61	2.43	2.27
4	4.66	4.16	3.78	3.48	3.23	3.03
5	5.82	5.20	4.72	4.35	4.04	3.79
6	6.99	6.24	5.67	5.21	4.85	4.55
7	8.15	7.28	6.61	6.08	5.66	5.31
8	9.32	8.32	7.56	6.95	6.47	6.07
9	10.48	9.36	8.50	7.82	7.28	6.83
10	11.65	10.40	9.45	8.69	8.08	7.58

**Table 2-9: Coolant Volumes and Temperatures**

Chassis	Liquid Volume/ Element in Gallons	Liquid Ref. Temperature, Input in °F (°C)	Max. Temp. Rise During Circulation in °F (°C)
CH3	0.03	86 (30)	9 (5)
CH4	0.04	86 (30)	9 (5)
CH5	0.06	86 (30)	9 (5)
CH61	0.10	86 (30)	9 (5)
CH62	0.10	86 (30)	9 (5)
CH63	0.10	86 (30)	9 (5)
CH64	0.10	86 (30)	9 (5)
CH72	0.42	86 (30)	9 (5)
CH74	0.42	86 (30)	9 (5)

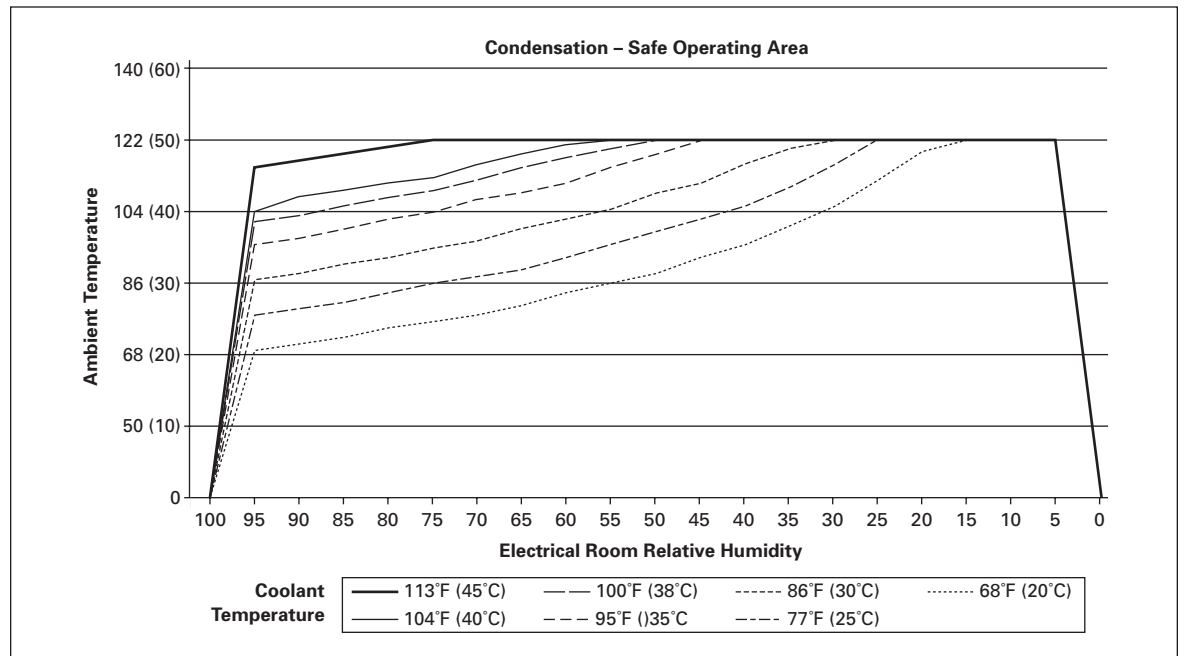
**Note:** In order to ensure sufficient cooling of boards, capacitors and DC-buses, Liquid-Cooled drives of chassis CH4 are equipped with one additional fan per module. The fan is placed underneath the module and it is supplied externally. See **Page 2-22**.

September 2007

**Condensation**

Condensation on the cooling plate of the liquid-cooled drive must be avoided. Therefore, the temperature of the cooling liquid must be kept higher than the temperature of the electrical room. Use **Figure 2-17** to determine if the drive operating conditions (combination of room temperature, humidity and cooling liquid temperature) are safe, or, to find the acceptable temperature for the cooling liquid.

The conditions are safe when the point is below the respective curve. If not, take adequate precautions by decreasing the room temperature and/or the relative humidity or increase the cooling liquid temperature. Note that increasing the temperature of the cooling liquid above figures in loadability charts decreases the nominal output current of the drive. The below curves are valid at sea level — 14.7 psi (1013 mbar).



**Figure 2-17: Safe Operating Conditions in Relation to Condensation**

### Cooling System Connections

The external cooling system shall be connected to each one of the cooling elements of the drive.

**Note:** The cooling elements must **NOT** be connected in series.

The cooling elements are equipped with hoses (Technobel Noir Tricoflex, P/N 135855) 1.5m in length and 16 mm in diameter (CH5, CH6, CH7). The hoses are inserted in 1400 mm UL94V0 approved conduits (type HFX40). These hoses have screw type connectors with internal thread. The connection of the hoses is made on the aluminum adapter (external thread) of the cooling element. Avoid any twisting of the hose on the element while connecting the line hose.



Figure 2-18: Aluminum Hose Adapters



Figure 2-19: External Thread of Hose Adapter

For all other chassis (CH3, CH4), the standard delivery includes fast connectors of type "Tema", series 1300 or 1900. The fast connectors are also available as an option also for CH5, CH6, CH7.

**Table 2-10: Liquid Connector Types (All Pressure Values at Nominal Flow)**

Chassis	Thread on Element (Internal) BSPP <sup>①</sup>	Connector Type or Hose Type	Thread (Cust.) BSPP <sup>②</sup>	Max. Pressure (Entire System)	Pressure Loss (Fast Connector + Element)	Pressure Loss (Hoses + Element)
CH3	G3/8"	1300NE2 1/4"	—	87 psi (6 bar)	3.6 psi (.25 bar)	—
CH4	G3/8"	1300NE2 1/4"	—	87 psi (6 bar)	3.6 psi (.25 bar)	—
CH5	G3/4"	Technobel 16*23.5	G1/2"	87 psi (6 bar)	—	2.9 psi (.2 bar)
CH6	G3/4"	Technobel 16*23.5	G1/2"	87 psi (6 bar)	—	7.3 psi (.5 bar)
CH7	G3/4"	Technobel 16*23.5	G1/2"	87 psi (6 bar)	—	10.2 psi (.7 bar)

<sup>①</sup> Use sealing (e.g. Usit-R Metal washer-rubber sealing) for this type of connection.

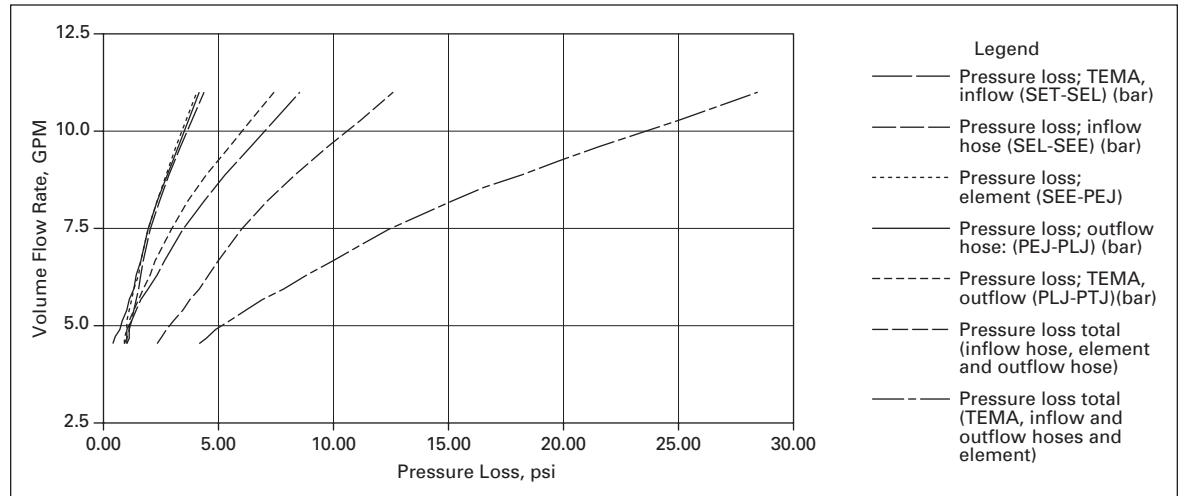
<sup>②</sup> Use sealant or sealing tape for this type of connection.

September 2007

**Pressure Losses**

**Table 2-11: Pressure Losses — CH6x**

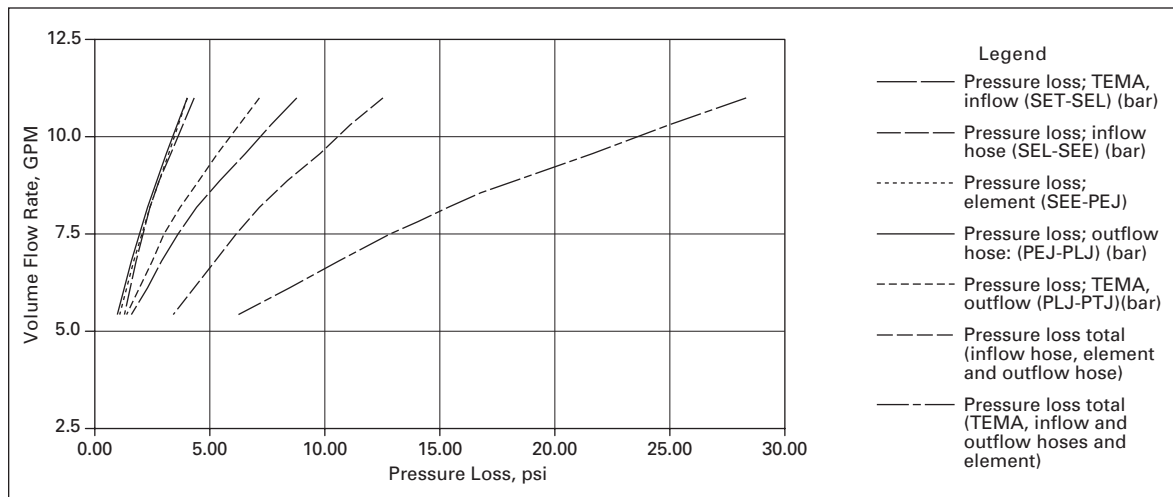
CH6x with standard 1.5m hoses and optional fast connectors TEMA							
Volume Flow Rate (GPM)	Pressure Loss TEMA Inflow (psi)	Pressure Loss Inflow Hose (psi)	Pressure Loss Element (psi)	Pressure Loss Outflow Hose (psi)	Pressure Loss TEMA Outflow (psi)	Pressure Loss Total Inflow Hose, Element and Outflow Hose (psi)	Pressure Loss Total TEMA, Inflow and Outflow Hoses and Element (psi)
10.6	8.56	4.35	4.06	4.06	7.40	12.62	28.43
7.9	4.35	2.47	2.32	2.32	3.63	7.12	15.08
5.3	1.45	1.31	1.16	1.02	1.31	3.48	6.24
4.5	0.87	1.02	0.87	0.44	1.02	2.32	4.21



**Figure 2-20: Pressure Loss — CH6x**

**Table 2-12: Pressure Losses — CH7x**

CH7x (16) with standard 1.5m hoses and optional fast connectors TEMA							
Volume Flow Rate (GPM)	Pressure Loss TEMA Inflow (psi)	Pressure Loss Inflow Hose (psi)	Pressure Loss Element (psi)	Pressure Loss Outflow Hose (psi)	Pressure Loss TEMA Outflow Hose (psi)	Pressure Loss Total Inflow Hose, Element and Outflow Hose (psi)	Pressure Loss Total TEMA, Inflow and Outflow Hoses and Element (psi)
10.57	8.85	4.35	4.06	4.06	7.25	12.62	28.57
7.93	4.50	2.47	2.47	2.23	3.77	7.25	15.52
5.28	1.60	1.31	1.16	1.02	1.45	3.48	6.38



**Figure 2-21: Pressure Loss — CH7x**

It is strongly recommended that the liquid carrying hoses from the network to the cooling elements of the drive are electrically non-conducting (to avoid electrical short circuits if the hose touches live parts). To avoid electrochemical corrosion, we also recommend adding an inhibitor (e.g. Ferrolux 332/Henkel, Cortec VpCl-649I) in the cooling liquid.

The following main line hose materials are acceptable:

- plastic (PVC)
- rubber (EPDM only)
- aluminium
- other stainless and acid-proof materials

The hoses must tolerate a **peak pressure** of 580 psi (40 bar).

Connect the line hose to its counterpart (screw connector or fast connector) on the cooling element of the drive/inverter. The coolant inlet connector is the one closer to the mounting plate and the outlet connector is the one closer to the face of the drive, see **Figure 2-23**. Due to high pressure in the line hose, it is recommended that the liquid line is equipped with a shut-off valve, which makes the connection easier. In order to prevent water from spraying in the installation room, Eaton also recommends wrapping e.g. linters around the connection during installation.

Eaton also recommends equipping the pipe branches to the cooling elements with valves.



September 2007

**Installation of Flow Switch**

As stated on **Page 2-14**, Eaton recommends the installation of the flow supervision in the liquid cooling system. If requested, Eaton delivers the flow switch as an option. The application of the flow switch as well as notes concerning its installation are given below.

**About Flow Switch Installation**

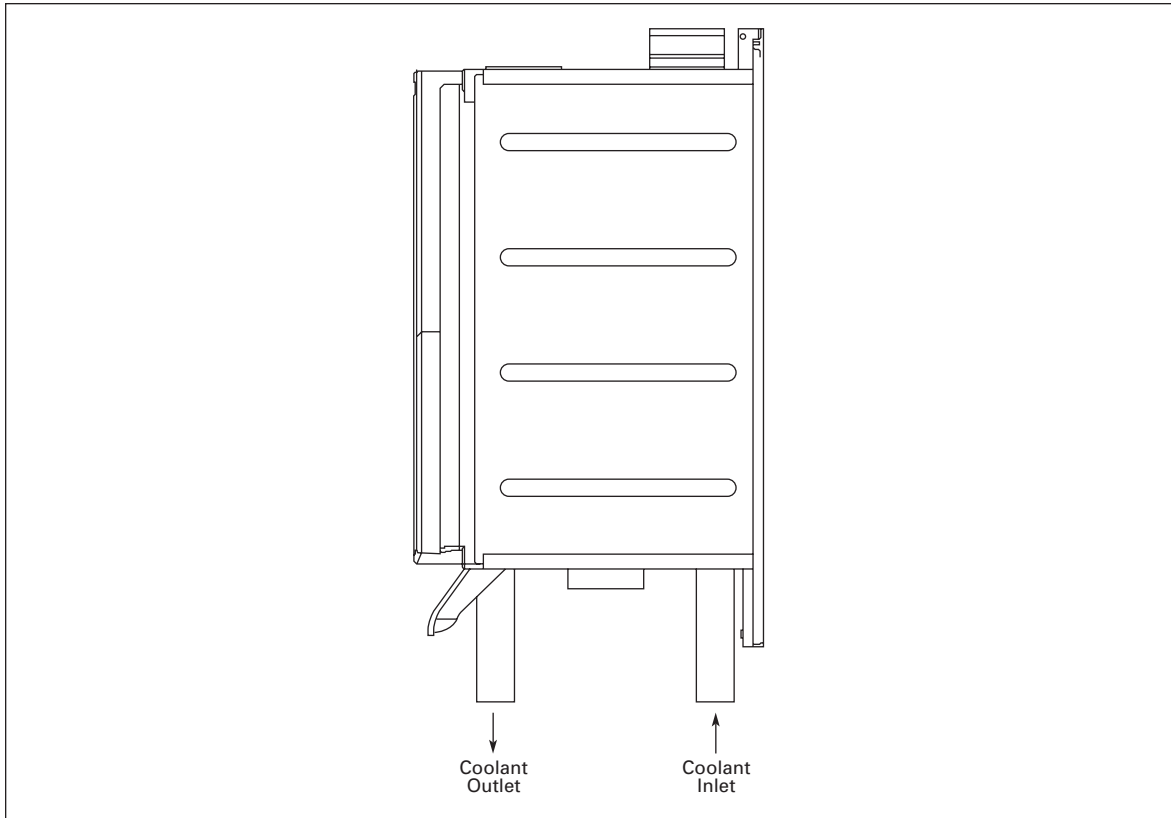
Eaton recommends mounting the flow switch on the inflow side of the system (see **Figure 2-15**. Pay attention to the direction of flow. The switch reaches the highest accuracy when it is mounted in horizontal position. If mounted vertically, the mechanical sensor is affected by the Earth’s gravity which reduces the accuracy according to the data given in **Table 2-13**.



**Figure 2-22: Flow Switch: Hose Connection, Fast Connector (Electrical), Fast Connector Lock Screw, Cable Seal and Clamp**

**Table 2-13: Flow Switch Data**

Description	Specification
Hose Connection	G1/2" female, internal thread ISO228-1
Closing	The switch closes if the flow exceeds 5.3 GPM
Switching Accuracy: Horizontal installation Vertical Installation	-5 – +15% (5.0 – 6.1 GPM) ±5% (5.0 – 5.5 GPM)



**Figure 2-23: Direction of Coolant Circulation**

#### ***External Cooling Fan for CH4***

In order to provide sufficient cooling for the power board, capacitors and DC-buses in the liquid-cooled drive of chassis CH4, one additional cooling fan and a steel pallet for mounting are included in the standard delivery.

The fan should be mounted underneath the module on the steel pallet with four 5.8 mm screws and it needs a +24V external power supply.

See **Page B-13** for drawings of the fan and the mounting pallet.

September 2007

## Drive Derating

The tables below state the maximum coolant temperatures for Cutler-Hammer liquid-cooled drives at given switching frequencies. Drive derating is required if the maximum temperatures are exceeded.

**Table 2-14: Maximum Temperatures of Coolant at Switching Frequency of 3.6 kHz**

Chassis	Type	Max. Coolant Temperature (°C) @ Supply Voltage	Max. Coolant Temperature (°C) @ Supply Voltage
<b>Supply Voltage 400 – 500V AC</b>			
CH61	LCX385A0-4	47 @ 400V	43 @ 500V
CH62	LCX730A0-4	40 @ 400V	37 @ 500V
CH63	LCXH11A0-4	38 @ 400V	36 @ 500V
CH64	LCXH20A0-4	37 @ 400V	34 @ 500V
CH64	LCXH23A0-4	42 @ 400V	40 @ 500V
CH72	LCX730A0-4	42 @ 400V	40 @ 500V
CH74	LCXH20A0-4	37 @ 400V	34 @ 500V
CH74	LCXH23A0-4	37 @ 400V	34 @ 500V
<b>Supply Voltage 525 – 690V AC</b>			
CH61	LCX261A0-5	45 @ 525V	39 @ 690V
CH62	LCX502A0-5	41 @ 525V	33 @ 690V
CH63	LCX750A0-5	42 @ 525V	36 @ 690V
CH64	LCXH15A0-5	41 @ 525V	34 @ 690V
CH72	LCX502A0-5	38 @ 525V	32 @ 690V
CH74	LCXH15A0-5	41 @ 525V	34 @ 690V

**Table 2-15: Maximum Temperatures of Coolant at Switching Frequency of 1.5 kHz**

Chassis	Type	Max. Coolant Temperature (°C) @ Supply Voltage	Max. Coolant Temperature (°C) @ Supply Voltage
<b>Supply Voltage 400 – 500V AC</b>			
CH61	LCX385A0-4	52 @ 400V	49 @ 500V
CH62	LCX730A0-4	47 @ 400V	45 @ 500V
CH63	LCXH11A0-4	44 @ 400V	42 @ 500V
CH64	LCXH20A0-4	49 @ 400V	47 @ 500V
CH64	LCXH23A0-4	44 @ 400V	42 @ 500V
CH72	LCX730A0-4	45 @ 400V	43 @ 500V
CH74	LCXH20A0-4	49 @ 400V	47 @ 500V
CH74	LCXH23A0-4	44 @ 400V	43 @ 500V
<b>Supply Voltage 525 – 690V AC</b>			
CH61	LCX261A0-5	54 @ 525V	51 @ 690V
CH62	LCX502A0-5	52 @ 525V	47 @ 690V
CH63	LCX750A0-5	53 @ 525V	50 @ 690V
CH64	LCXH15A0-5	52 @ 525V	47 @ 690V
CH72	LCX502A0-5	51 @ 525V	46 @ 690V
CH74	LCXH15A0-5	52 @ 525V	48 @ 690V

## Input Chokes

The input choke carries out several functions in the Cutler-Hammer liquid-cooled drive. Connection of the input choke is necessary except if you have a component in your system that performs the same tasks (e.g. a transformer). The input choke is needed as an essential component for motor control, to protect the input and DC-link components against abrupt changes of current and voltage as well as to function as a protection against harmonics.

The input chokes are included in the standard delivery of Cutler-Hammer liquid-cooled drives. However, you can also order your drive without the choke.

The Cutler-Hammer chokes listed in **Table 2-16** are meant for supply voltages of 400 – 500V and 525 – 690V.

**Table 2-16: Input Choke Dimensioning, 6-Pulse Supply**

Converter Amperages (400 – 500V AC)	Converter Amperages (690V AC)	Choke Type	Thermal Current (A)	Nominal Inductance (µH) A/B <sup>①</sup>	Calculated Loss (W)
16 – 22	12 – 23	CHK0023N6A0	23	1900	145
31 – 38	31 – 38	CHK0038N6A0	38	1100	170
45 – 61	46 – 62	CHK0062N6A0	62	700	210
72 – 87	72 – 87	CHK0087N6A0	87	480	250
105 – 140	105 – 140	CHK0145N6A0	145	290	380
168 – 261	170 – 261	CHK0261N6A0	261	139/187	460
300 – 385	325 – 385 <b>820 – 1180</b> <b>1850 – 2340</b>	CHK0400N6A0	400	90/126	610
460 – 520 <b>1370 (CH74)</b>	416 – 502 <b>1300 – 1500</b> <b>2700 – 3100</b>	CHK0520N6A0	520	65/95	810
590 – 650 <b>1640</b>	590 – 650 <b>1700 – 1900</b>	CHK0650N6A0	650	51/71	890
730 <b>2060</b>	750	CHK0750N6A0	750	45/61	970
820 <b>2300</b>	—	CHK0820N6A0	820	39/53	1020
920 – 1030	—	CHK1030N6A0	1030	30/41	1170
1150	—	CHK1150N6A0	1150	26/36	1420
<b>2470 – 2950</b>	—	CHK0520N6A0	520	65/95	810
<b>3710</b>	—	CHK0650N6A0	650	51/71	890
<b>4140</b>	—	CHK0750N6A0	750	45/61	970

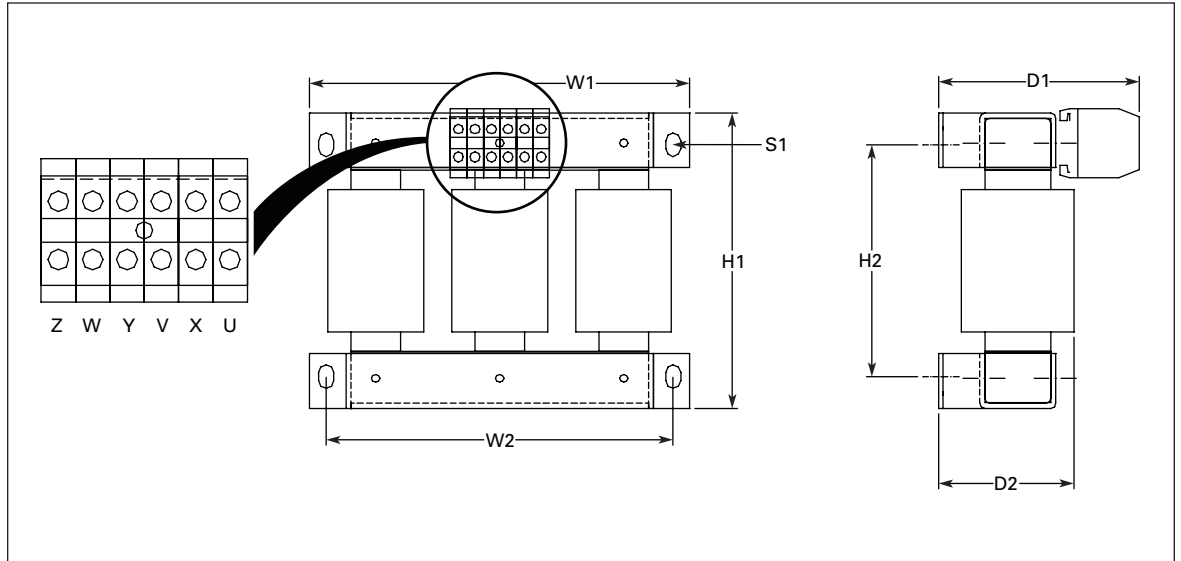
<sup>①</sup> Inductances for different supply voltages: A = 400 – 480V AC, B = 500 – 690V AC. See **Table 2-17**.

Converter amperages written in **bold italic** require three (3) chokes of the designated kind per unit with 6-pulse supply.

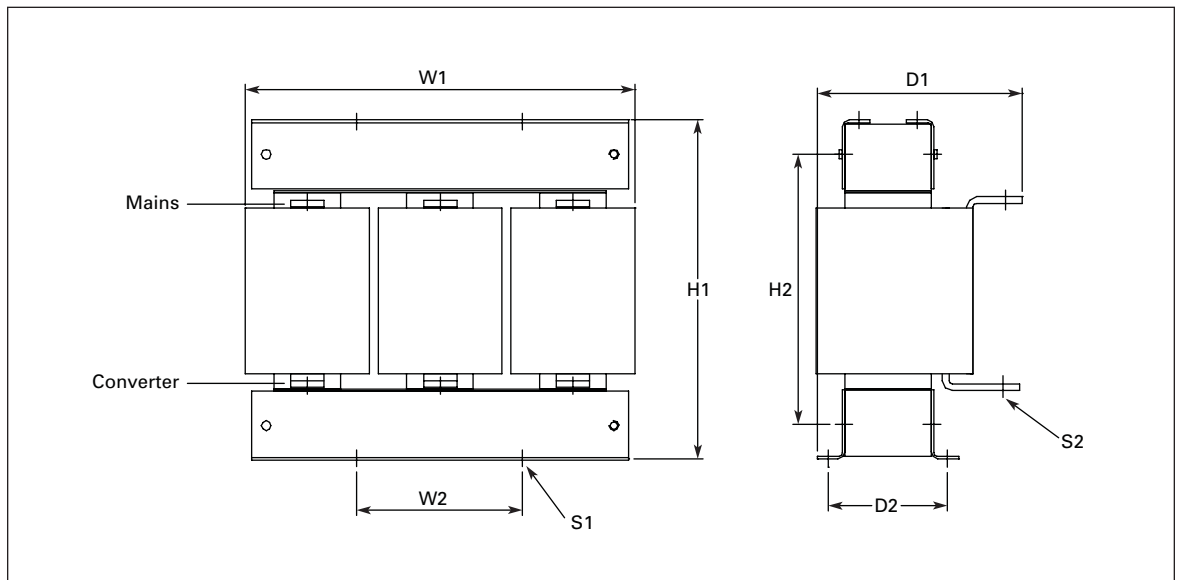
September 2007

**Installation of Input Choke**

There are two types of input choke connection in LCX9000 Liquid-Cooled drives. The two smallest sizes (CH31, CH32; up to 61A) have terminal block connection whereas bigger sizes use busbar connection. Examples of both connections and the choke dimensions below.



**Figure 2-24: Example of Input Chokes for Liquid-Cooled Sizes Up to 62A**



**Figure 2-25: Example of Input Chokes for Liquid-Cooled Sizes 87 – 145A and 590A**

**Table 2-17: Choke Dimensions Sizes 23 – 145A and 590A**

Choke Type	Approximate Dimensions in Inches (mm)								Weight in Lbs. (kg)
	H1	H2	W1	W2	D1	D2	S1	S2 Dia.	
CHK0023N6A0	7.01 (178)	5.51 (140)	9.06 (230)	8.27 (210)	4.76 (121)	3.23 (82)	.35x.55 (4 pcs) (9x14)	—	22 (10)
CHK0038N6A0	8.23 (209)	6.42 (163)	10.63 (270)	9.84 (250)	—	—	.35x.55 (6 pcs) (9x14)	—	33 (15)
CHK0062N6A0	8.39 (213)	6.10 (155)	11.81 (300)	11.02 (280)	—	—	.35x.55 (4 pcs) (9x14)	—	44 (20)
CHK0087N6A0	9.13 (232)	6.85 (174)	11.81 (300)	11.02 (280)	6.69 (170)	—	.35x.55 (4 pcs) (9x14)	.35 (6 pcs) (9)	57 (26)
CHK0145N6A0	11.50 (292)	9.21 (234)	11.81 (300)	11.02 (280)	7.28 (185)	—	.35x.55 (4 pcs) (9x14)	.35 (6 pcs) (9)	81 (37)
CHK0590N6A0	20.43 (519)	—	15.51 (394)	12.44 (316)	10.71 (272)	6.50 (165)	.39x1.38 (4 pcs) 10x35	.43 (6 pcs) (11)	275 (125)

Always connect the supply cables to the choke terminals marked with #1 (see **Figure 2-26**). Choose the converter connection according to **Figure 2-26**.

September 2007

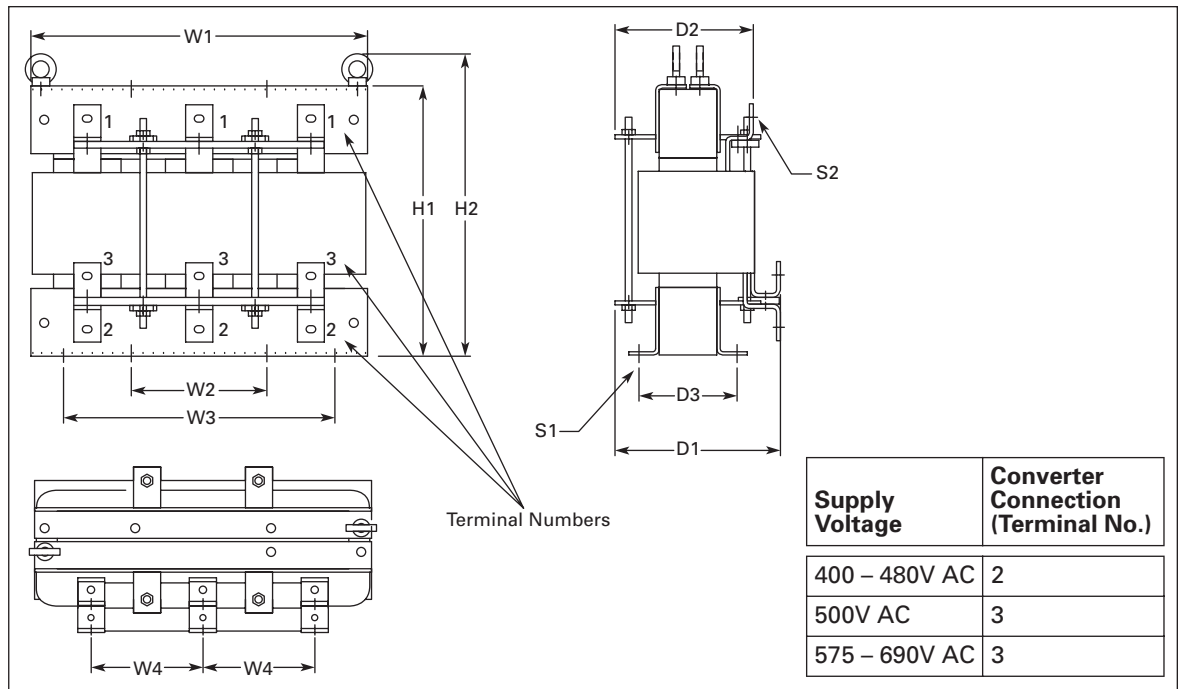


Figure 2-26: Example of Input Chokes for Liquid-Cooled Sizes 261 – 1150A

Table 2-18: Choke Dimensions Sizes 261 – 1150A

Choke Type	Approximate Dimensions in Inches (mm)											Weight in Lbs. (kg)
	H1	H2	W1	W2	W3	W4	D1	D2	D3	S1	S2 Dia.	
CHK0261N6A0	12.56 (319)	14.06 (357)	13.94 (354)	5.91 (150)	10.83 (275)	4.72 (120)	9.06 (230)	8.11 (206)	4.25 (108)	.35x.55 (9x14) (8 pcs)	.35x.55 (9x14) (9 pcs)	117 (53)
CHK0400N6A0	15.08 (383)	16.57 (421)	13.78 (350)	5.91 (150)	10.83 (275)	4.72 (120)	10.31 (262)	9.37 (238)	5.51 (140)	.35x.55 (9x14) (8 pcs)	.43x.59 (11x15) (9 pcs)	185 (84)
CHK0520N6A0	15.71 (399)	17.56 (446)	19.57 (497)	7.87 (200)	15.75 (400)	6.50 (165)	9.61 (244)	8.03 (204)	5.71 (145)	.51 dia. (13) (8 pcs)	.43x.59 (11x15) (9 pcs)	253 (115)
CHK0650N6A0	17.68 (449)	19.53 (496)	19.57 (497)	7.87 (200)	15.75 (400)	6.50 (165)	9.61 (244)	8.11 (206)	5.71 (145)	.51 dia. (13) (8 pcs)	.43x.59 (11x15) (9 pcs)	286 (130)
CHK0750N6A0	19.25 (489)	20.75 (527)	19.57 (497)	7.87 (200)	15.75 (400)	6.50 (165)	10.75 (273)	9.09 (231)	6.69 (170)	.51 dia. (13) (8 pcs)	.51x.71 (13x8) (9 pcs)	374 (170)
CHK0820N6A0	19.33 (491)	20.83 (529)	19.57 (497)	7.87 (200)	15.75 (400)	6.50 (165)	10.75 (273)	9.09 (231)	6.69 (170)	.51 dia. (13) (8 pcs)	.51x.71 (13x8) (9 pcs)	374 (170)
CHK1030N6A0	24.80 (630)	26.65 (677)	19.57 (497)	7.87 (200)	15.75 (400)	6.50 (165)	12.09 (307)	9.49 (241)	6.69 (170)	.51 dia. (13) (8 pcs)	.51x.71 (13x8) (36 pcs)	469 (213)
CHK1150N6A0	24.80 (630)	26.65 (677)	19.57 (497)	7.87 (200)	15.75 (400)	6.50 (165)	12.09 (307)	9.49 (241)	6.69 (170)	.51 dia. (13) (8 pcs)	.51x.71 (13x8) (36 pcs)	469 (213)

If you have ordered the input chokes for the liquid-cooled drive separately, pay attention to the following instructions:

1. Protect the chokes from dripping water. You may even need to use plexiglass for protection because jets of water may occur when working with the connections.

## 2. Connection of cables:

### Types CHK0023N6A0, CHK0038N6A0, CHK0062N6A0 (chokes with terminal blocks)

The terminals are marked with letters U, V, W and X, Y and Z such that terminals U and X, V and Y as well as W and Z form pairs of which one is an input and the other an output. Furthermore, terminals U, V and W must all be used as either input or output. The same applies to terminals X, Y and Z. See **Figure 2-24**.

**Example:** If you connect the mains cable of one phase to terminal X, the other two phases must be connected to Y and Z. Accordingly, the choke output cables are connected to their corresponding input pairs: phase 1 → U, phase 2 → V and phase 3 → W.

### Other types (chokes with busbar connection)

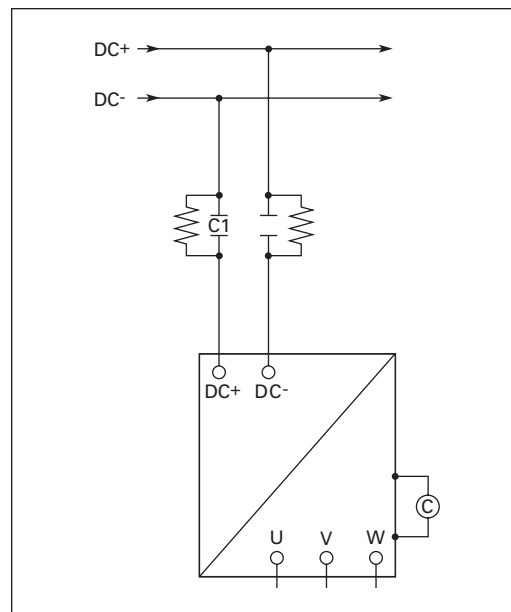
Connect the mains cables to the upper busbar connectors (see **Figures 2-25 and 2-26**) with bolts. The cables to the drive are bolted to the lower connectors. See **Table 2-18** for bolt sizes.

## Inverter Charging Circuit

The charging circuit of LCX9000 Liquid-Cooled inverters can be controlled with a contactor and a charging resistor.

**Table 2-19: Resistor Used for Charging Circuits**

Type	Nominal Rating T=350°; @25°C	Max Voltage	Resistance, ±10%
Danothrm ZRF 30/165	165W	1200V	33Ω



**Figure 2-27: Charging Circuit**

### **Control with Contactor**

When the inverter charging circuit is controlled with a contactor, an auxiliary voltage transformer must be used. Note local conditions of the supply voltage.



September 2007

## Chapter 3 — Power Wiring

How the power connections of LCX9000 Liquid-Cooled units are implemented depends on the size of the unit. The smallest liquid-cooled unit (CH3) has terminal blocks for the connections. In all other units, the connection is established using cables and cable clips or bolting the busbars together.

The main circuit diagrams of each Liquid-Cooled drive chassis are in **Appendix B**.

### Power Connections

Use cables with heat resistance of at least +158°F (+70°C). The cables and the fuses must be sized according to the drive nominal OUTPUT current that you can find on the rating plate. Sizing according to the output current is recommended because the drive input current never significantly exceeds the output current. Installation of cables according to UL regulations is presented on **Page 3-13**.

In chassis CH5 and greater, the field cables (both motor and mains) should be connected to a specific cable connection block (optional equipment). However, inside a switchgear, the cable connection can be made directly to the drive.

**Table 3-5** shows the minimum sizes of the Cu-cables and the corresponding aR fuse sizes.

If the motor temperature protection of the drive (see the application manual) is used as an overload protection, the cable should be chosen accordingly. If three or more cables are used in parallel, each cable requires a separate overload protection.

These instructions apply only to cases with one motor and one cable connection from the drive to the motor. In any other case, ask Eaton for more information.

#### ***Mains Cable***

The mains cables of size CH31 are connected to terminal blocks (see **Figure 2-2**), whereas busbar connection is used for larger sizes, see drawings on **Pages 2-2 to 2-11**. Mains cable type for EMC level N is in **Table 3-1**.

#### ***Motor Cable***

In order to avoid current sharing disbalance, it is imperative to use symmetrical motor cables. Eaton also recommends always using shielded cable whenever possible.

The motor cables of size CH31 are connected to terminal blocks (see **Figure 2-2**), whereas busbar connection is used for larger sizes, see drawings on **Pages 2-2 to 2-11**. Motor cable type for EMC level N is in **Table 3-1**.

Ask Eaton for more information on the use of ferrite cores with the motor cable in order to protect the motor bearings against motor bearing currents.

For information on control cables see **Page 4-6** and **Table 3-1**.

**Table 3-1: Cable Types Required to Meet Standards**

Cable Type	Level N/T
Mains Cable	Power cable intended for fixed installation and the specific mains voltage. Shielded cable not required.
Motor Cable	Power cable intended for fixed installation and the specific mains voltage. Shielded cable not required.
Control Cable	Screened cable equipped with compact low-impedance shield.

**Cable Data****Table 3-2: Cable Sizes 400 – 500V**

Chassis	Catalog Number	$I_{th}$	Mains and Motor Cable Cu (mm <sup>2</sup> )	Terminal Cable Size		Max. Number of Cables/Bolt Size
				Main Terminal (mm <sup>2</sup> ), Max.	Ground Terminal (mm <sup>2</sup> )	
CH3	LCX016A0-4	16	3x2.5+2.5	50	1 – 10	③
	LCX022A0-4	22	3x4+4	50	1 – 10	③
	LCX031A0-4	31	3x6+6	50	1 – 10	③
	LCX038A0-4 LCX045A0-4	38 – 45	3x10+10	50 Cu 50 Al	6 – 35	③
	LCX061A0-4	61	3x16+16	50 Cu 50 Al	6 – 35	③
CH4	LCX072A0-4	72	3x25+16	50 Cu 50 Al	6 – 70	1/M8
	LCX087A0-4	87	3x35+16	50 Cu 50 Al	6 – 70	1/M8
	LCX105A0-4	105	3x50+25	50 Cu 50 Al	6 – 70	1/M8
	LCX140A0-4	140	3x70+35	95 Cu/Al	25 – 95	1/M8
CH5	LCX168A0-4	168	3x95+50	185 Cu/Al	25 – 95	2/M10
	LCX205A0-4	205	3x150+70	185 Cu/Al	25 – 95	2/M10
	LCX261A0-4	261	3x185+95 or 2x(3x120+70)	185 Cu/Al 2	25 – 95	2/M10
CH61	LCX300A0-4	300	3x240+120	①	25 – 185	2/M12
	LCX385A0-4	385	2x(3x120+70)	①	25 – 185	2/M12
CH62/72	LCX460A0-4	460	2x(3x150+70)	②	25 – 185	4/M12
	LCX520A0-4	520	2x(3x185+95)	②	25 – 185	4/M12
	LCX590A0-4 LCX650A0-4	590 650	3x(3x150+70)	②	25 – 185	4/M12
	LCX730A0-4	730	3x(3x150+70)	②	25 – 185	4/M12

① Number of bolt connections = 2.

② Number of bolt connections = 4.

③ See Main Terminal Cable Size.

September 2007

**Table 3-2: Cable Sizes 400 – 500V (Continued)**

Chassis	Catalog Number	I <sub>th</sub>	Mains and Motor Cable Cu (mm <sup>2</sup> )	Terminal Cable Size		Max. Number of Cables/Bolt Size
				Main Terminal (mm <sup>2</sup> ), Max.	Ground Terminal (mm <sup>2</sup> )	
CH63	LCX820A0-4	820	3x(3x185+95)	②	③	8/M12
	LCX920A0-4	920	4x(3x185+95)	②	③	8/M12
	LCXH10A0-4	1030	4x(3x185+95)	②	③	8/M12
CH64	LCXH13A0-4	1370	5x(3x185+95)	②	③	8/M12
	LCXH16A0-4	1640	6x(3x185+95)	②	③	8/M12
	LCXH20A0-4	2060	7x(3x185+95)	②	③	8/M12
	LCXH23A0-4	2300	8x(3x185+95)	②	③	8/M12
CH74 ①	LCXH13A0-4	1370	5x(3x185+95)	②	③	4/M12
	LCXH16A0-4	1640	6x(3x185+95)	②	③	4/M12
	LCXH20A0-4	2060	7x(3x185+95)	②	③	4/M12
	LCXH23A0-4	2300	8x(3x185+95)	②	③	4/M12

① Due to insufficient number of terminal bolt connections for required number of cables, the cabinet must be equipped with an external flexible cable connection block at both mains and motor ends if stiff cable type is used. See also **Page 3-11, Step 5**.

② Number of bolt connections = 4.

③ Three grounding terminals per mounting plate, see **Page 3-13**.

**Units with 6-pulse supply:**

Note that all other sizes have three input terminals except for size CH74, which has nine input terminals.

**Units with 12-pulse supply:**

12-pulse supply can be used with drives of sizes CH72 and CH74. The number of input terminals for both is six.

If 12-pulse supply is used, also consider the fuse selection, see **Pages 3-5 and 3-6**.

**Table 3-3: Cable Sizes 525 – 690V**

Chassis	Catalog Number	I <sub>th</sub>	Mains and Motor Cable Cu (mm <sup>2</sup> )	Terminal Cable Size		Max. Number of Cables/Bolt Size
				Main Terminal (mm <sup>2</sup> ), Max.	Ground Terminal (mm <sup>2</sup> )	
CH61	LCX170A0-5	170	3x95+50	185 Cu/Al	25 – 95	2/M12
	LCX208A0-5	208	3x150+70	185 Cu/Al	25 – 95	2/M12
	LCX261A0-5	261	3x185+95	185 Cu/Al 2	25 – 95	2/M12
CH62/72	LCX325A0-5	325	2x(3x95+50)	②	25 – 185	4/M12
	LCX385A0-5	385	2x(3x120+70)	②	25 – 185	4/M12
	LCX416A0-5	416	2x(3x150+70)	②	25 – 185	4/M12
	LCX460A0-5	460	2x(3x185+95)	②	25 – 185	4/M12
	LCX502A0-5	502	2x(3x185+95)	②	25 – 185	4/M12
CH63	LCX590A0-5	590	3x(3x150+70)	②	③	8/M12
	LCX650A0-5	650	3x(3x150+70)	②	③	8/M12
	LCX750A0-5	750	3x(3x185+95)	②	③	8/M12
CH74 ①	LCX820A0-5	820	4x(3x150+70)	②	③	4/M12
	LCX920A0-5	920	4x(3x185+95)	②	③	4/M12
	LCXH10A0-5	1030	4x(3x185+95)	②	③	4/M12
	LCXH11A0-5	1180	5x(3x185+95)	②	③	4/M12
	LCXH13A0-5	1300	5x(3x185+95)	②	③	4/M12
	LCXH15A0-5	1500	6x(3x185+95)	②	③	4/M12

① Due to insufficient number of terminal bolt connections for required number of cables, the cabinet must be equipped with an external flexible cable connection block at both mains and motor ends if stiff cable type is used. See also **Page 3-11, Step 5**.

② Number of bolt connections = 4.

③ Three grounding terminals per mounting plate, see **Page 3-13**.

See the tightening torques of bolts in **Table 3-4**.

**Table 3-4: Tightening Torques of Bolts**

Bolt	Tightening Torque in in-lb (Nm)	Max. Inward Thread Length (mm)
M8	177 (20)	10
M10	354 (40)	22
M12	620 (70)	22

We recommend a low-impedance grounding of the motor cable shield for better performance.

Because of several possible cable installations and environmental conditions, it is very important to consider **local regulations** and the **IEC/EN standards**.

September 2007

**Fuse Sizes, Drives**

The fuse sizing in the tables below is based on Bussman aR fuses. We recommend use of these fuses. Sufficient protection against short circuit cannot be guaranteed if other fuse types are used.

**Table 3-5: Fuse Sizes for LCX9000 Liquid-Cooled (500V) Drives**

Chassis	Catalog Number	I <sub>th</sub> (A)	DIN43620		DIN43653 (80 mm)		DIN43653 (110 mm)		Fuse U <sub>n</sub> (V)	Fuse I <sub>n</sub> (A)	Qty. of Fuses per Phase 3~
			aR Fuse Part No.	Fuse Size	aR Fuse Part No.	Fuse Size	aR Fuse Part No.	Fuse Size			
CH3	LCX016A0-4	16	170M1565	DIN000	170M1415	000T/80	—	—	690	63	1
	LCX022A0-4	22	170M1565	DIN000	170M1415	000T/80	—	—	690	63	1
	LCX031A0-4	31	170M1565	DIN000	170M1415	000T/80	—	—	690	63	1
	LCX038A0-4	38	170M1565	DIN000	170M1415	000T/80	—	—	690	63	1
	LCX045A0-4	45	170M1567	DIN000	170M1417	000T/80	—	—	690	100	1
	LCX061A0-4	61	170M1567	DIN000	170M1417	000T/80	—	—	690	100	1
CH4	LCX072A0-4	72	170M3815	DIN1 ①	170M3065	1xTN/80	170M3215	1xTN/110	690	200	1
	LCX087A0-4	87	170M3815	DIN1 ①	170M3065	1xTN/80	170M3215	1xTN/110	690	200	1
	LCX105A0-4	105	170M3815	DIN1 ①	170M3065	1xTN/80	170M3215	1xTN/110	690	200	1
	LCX140A0-4	140	170M3815	DIN1 ①	170M3065	1xTN/80	170M3215	1xTN/110	690	200	1
CH5	LCX168A0-4	168	170M3819	DIN1 ①	170M3069	1xTN/80	170M3219	1xTN/110	690	400	1
	LCX205A0-4	205	170M3819	DIN1 ①	170M3069	1xTN/80	170M3219	1xTN/110	690	400	1
	LCX261A0-4	261	170M3819	DIN1 ①	170M3069	1xTN/80	170M3219	1xTN/110	690	400	1
CH61	LCX300A0-4	300	170M5813	DIN2	170M5063	2TN/80	170M5213	2TN/110	690	700	1
	LCX385A0-4	385	170M5813	DIN2	170M5063	2TN/80	170M5213	2TN/110	690	700	1
CH72	LCX460A0-4	460	170M6814	DIN3	170M6064	3TN/80	170M6214	3TN/110	690	1000	1
	<i>LCX460A0-4</i>	<i>460</i>	<i>170M5813</i>	<i>DIN2</i>	<i>170M5063</i>	<i>2TN/80</i>	<i>170M5213</i>	<i>2TN/110</i>	<i>690</i>	<i>700</i>	<i>2</i>
	LCX520A0-4	520	170M6814	DIN3	170M6064	3TN/80	170M6214	3TN/110	690	1000	1
	<i>LCX520A0-4</i>	<i>520</i>	<i>170M5813</i>	<i>DIN2</i>	<i>170M5063</i>	<i>2TN/80</i>	<i>170M5213</i>	<i>2TN/110</i>	<i>690</i>	<i>700</i>	<i>2</i>
	LCX590A0-4	590	170M6814	DIN3	170M6064	3TN/80	170M6214	3TN/110	690	1000	1
	<i>LCX590A0-4</i>	<i>590</i>	<i>170M5813</i>	<i>DIN2</i>	<i>170M5063</i>	<i>2TN/80</i>	<i>170M5213</i>	<i>2TN/110</i>	<i>690</i>	<i>700</i>	<i>2</i>
	LCX650A0-4	650	170M8547	3SHT ②	170M6066	3TN/80	170M6216	3TN/110	690	1250	1
	<i>LCX650A0-4</i>	<i>650</i>	<i>170M5813</i>	<i>DIN2</i>	<i>170M5063</i>	<i>2TN/80</i>	<i>170M5213</i>	<i>2TN/110</i>	<i>690</i>	<i>700</i>	<i>2</i>
	LCX730A0-4	730	170M8547	3SHT ②	170M6066	3TN/80	170M6216	3TN/110	690	1250	1
	<i>LCX730A0-4</i>	<i>730</i>	<i>170M5813</i>	<i>DIN2</i>	<i>170M5063</i>	<i>2TN/80</i>	<i>170M5213</i>	<i>2TN/110</i>	<i>690</i>	<i>700</i>	<i>2</i>
CH63	LCX820A0-4	820	170M6812	DIN3	170M6062	3TN/80	170M6212	3TN/110	690	800	2
	LCX920A0-4	920	170M6812	DIN3	170M6062	3TN/80	170M6212	3TN/110	690	800	2
	LCXH10A0-4	1030	170M6814	DIN3	170M6064	3TN/80	170M6214	3TN/110	690	1000	2
	LCXH11A0-4	1150	170M6814	DIN3	170M6064	3TN/80	170M6214	3TN/110	690	1000	2
CH74	LCXH13A0-4	1370	170M6814	DIN3	170M6064	3TN/80	170M6214	3TN/110	690	1000	3
	<i>LCXH13A0-4</i>	<i>1370</i>	<i>170M6812</i>	<i>DIN3</i>	<i>170M6062</i>	<i>3TN/80</i>	<i>170M6212</i>	<i>3TN/110</i>	<i>690</i>	<i>800</i>	<i>2</i>
	LCXH16A0-4	1640	170M6814	DIN3	170M6064	3TN/80	170M6214	3TN/110	690	1000	3
	<i>LCXH16A0-4</i>	<i>1640</i>	<i>170M6812</i>	<i>DIN3</i>	<i>170M6062</i>	<i>3TN/80</i>	<i>170M6212</i>	<i>3TN/110</i>	<i>690</i>	<i>800</i>	<i>4</i>
	LCXH20A0-4	2060	170M8547	3SHT ②	170M6066	3TN/80	170M6216	3TN/110	690	1250	3
	<i>LCXH20A0-4</i>	<i>2060</i>	<i>170M6814</i>	<i>DIN3</i>	<i>170M6064</i>	<i>3TN/80</i>	<i>170M6214</i>	<i>3TN/110</i>	<i>690</i>	<i>1000</i>	<i>4</i>
	LCXH23A0-4	2300	170M8547	3SHT ②	170M6066	3TN/80	170M6216	3TN/110	690	1250	3
<i>LCXH23A0-4</i>	<i>2300</i>	<i>170M6814</i>	<i>DIN3</i>	<i>170M6064</i>	<i>3TN/80</i>	<i>170M6214</i>	<i>3TN/110</i>	<i>690</i>	<i>1000</i>	<i>4</i>	

① T<sub>j</sub> = 77°F (25°C).

② SHT fuses can be assembled into DIN fuse base of the corresponding size.

**Note:** Data in italic refer to drives with 12-pulse supply.

Table 3-6: Fuse Sizes for LCX9000 Liquid-Cooled (690V) Drives

Chassis	Catalog Number	I <sub>th</sub> (A)	DIN43620		DIN43653 (80 mm)		DIN43653 (110 mm)		Fuse U <sub>n</sub> (V)	Fuse I <sub>n</sub> (A)	Qty. of Fuses per Phase 3~
			aR Fuse Part No.	Fuse Size	aR Fuse Part No.	Fuse Size	aR Fuse Part No.	Fuse Size			
CH61	LCX170A0-5	170	170M3819	DIN1 <sup>①</sup>	170M3069	1xTN/80	170M3219	1xTN/110	690	400	1
	LCX208A0-5	208	170M3819	DIN1 <sup>①</sup>	170M3069	1xTN/80	170M3219	1xTN/110	690	400	1
	LCX261A0-5	261	170M3819	DIN1 <sup>①</sup>	170M3069	1xTN/80	170M3219	1xTN/110	690	400	1
CH72	LCX325A0-5	325	170M5813	DIN2	170M5063	2TN/80	170M5213	2TN/110	690	700	1
	LCX325A0-5	325	170M3819	DIN1 <sup>①</sup>	170M3069	1xTN/80	170M3219	1xTN/110	690	400	2
	LCX385A0-5	385	170M5813	DIN2	170M5063	2TN/80	170M5213	2TN/110	690	700	1
	LCX385A0-5	385	170M3819	DIN1 <sup>①</sup>	170M3069	1xTN/80	170M3219	1xTN/110	690	400	2
	LCX416A0-5	416	170M6812	DIN3	170M6062	3TN/80	170M6212	3TN/110	690	800	1
	LCX416A0-5	416	170M3819	DIN1 <sup>①</sup>	170M3069	1xTN/80	170M3219	1xTN/110	690	400	2
	LCX460A0-5	460	170M6812	DIN3	170M6062	3TN/80	170M6212	3TN/110	690	800	1
	LCX460A0-5	460	170M3819	DIN1 <sup>①</sup>	170M3069	1xTN/80	170M3219	1xTN/110	690	400	2
	LCX502A0-5	502	170M6812	DIN3	170M6062	3TN/80	170M6212	3TN/110	690	800	1
	LCX502A0-5	502	170M3819	DIN1 <sup>①</sup>	170M3069	1xTN/80	170M3219	1xTN/110	690	400	2
CH63	LCX590A0-5	590	170M6814	DIN3	170M6064	3TN/80	170M6214	3TN/110	690	1100	1
	LCX650A0-5	650	170M8547	3SHT <sup>②</sup>	170M6066	3TN/80	170M6216	3TN/110	690	1250	1
	LCX750A0-5	750	170M8547	3SHT <sup>②</sup>	170M6066	3TN/80	170M6216	3TN/110	690	1250	1
CH74	LCX820A0-5	820	170M5813	DIN2	170M5063	2TN/80	170M5213	2TN/110	690	700	3
	LCX820A0-5	820	170M6812	DIN3	170M6062	3TN/80	170M6212	3TN/110	690	800	2
	LCX920A0-5	920	170M5813	DIN2	170M5063	2TN/80	170M5213	2TN/110	690	700	3
	LCX920A0-5	920	170M6812	DIN3	170M6062	3TN/80	170M6212	3TN/110	690	800	2
	LCXH10A0-5	1030	170M5813	DIN2	170M5063	2TN/80	170M5213	2TN/110	690	700	3
	LCXH10A0-5	1030	170M6814	DIN3	170M6064	3TN/80	170M6214	3TN/110	690	1000	2
	LCXH11A0-5	1180	170M5813	DIN2	170M5063	2TN/80	170M5213	2TN/110	690	700	3
	LCXH11A0-5	1180	170M6814	DIN3	170M6064	3TN/80	170M6214	3TN/110	690	1000	2
	LCXH13A0-5	1300	170M6814	DIN3	170M6064	3TN/80	170M6214	3TN/110	690	1000	3
	LCXH13A0-5	1300	170M8547	3SHT <sup>②</sup>	170M6066	3TN/80	170M6216	3TN/110	690	1250	2
	LCXH15A0-5	1500	170M6814	DIN3	170M6064	3TN/80	170M6214	3TN/110	690	1000	3
	LCXH15A0-5	1500	170M8547	3SHT <sup>②</sup>	170M6066	3TN/80	170M6216	3TN/110	690	1250	2

<sup>①</sup> T<sub>j</sub> = 77°F (25°C).

<sup>②</sup> SHT fuses can be assembled into DIN fuse base of the corresponding size.

**Note:** Data in italic refer to drives with 12-pulse supply.

### Fuse information

Max fuse ambient temperature +122°F (+50°C).

Fuse sizes can differ in the same chassis. Fuses can be chosen according to the highest current rating of the chassis to minimize fuse variants.

Check the current rating of the fuse bases according to the input current of the drive.

The physical size of the fuse is chosen on the basis of the fuse current: Current <400 amps (size 2 fuse or smaller), current <400 amps (size 3 fuse).

September 2007

**Fuse Sizes, Inverters**

Each DC supply line must be equipped with an aR fuse according to **Table 3-7**.

The fuse sizing in **Tables 3-7 – 3-10** is based on Bussman aR fuses. We recommend you use these fuses. Sufficient protection against short-circuit cannot be guaranteed if other fuse types are used. Also, substitution of the fuse values given in **Tables 3-7 – 3-10** with those of the other fuse manufacturers is not recommended. In case you wish to use fuses of other fuse manufacturers, contact Eaton.

**Table 3-7: Fuse Sizes for LCX9000 Liquid-Cooled (450 – 800V) Inverters**

Chassis	Catalog Number	I <sub>th</sub> (A)	DIN43620		DIN43653 (80 mm)		DIN43653 (110 mm)		Fuse U <sub>n</sub> (V)	Fuse I <sub>n</sub> (A)	Qty. of Fuses/ Poles
			aR Fuse	Fuse Size	aR Fuse	Fuse Size	aR Fuse	Fuse Size			
CH3	LCX016A0-4	16	170M3810	DIN1 ①	170M3060	1xTN/80	170M3210	1xTN/110	690	63	1
	LCX022A0-4	22	170M3810	DIN1 ①	170M3060	1xTN/80	170M3210	1xTN/110	690	63	1
	LCX031A0-4	31	170M3810	DIN1 ①	170M3060	1xTN/80	170M3210	1xTN/110	690	63	1
	LCX038A0-4	38	170M3813	DIN1 ①	170M3063	1xTN/80	170M3213	1xTN/110	690	125	1
	LCX045A0-4	45	170M3813	DIN1 ①	170M3063	1xTN/80	170M3213	1xTN/110	690	125	1
	LCX061A0-4	61	170M3813	DIN1 ①	170M3063	1xTN/80	170M3213	1xTN/110	690	125	1
CH4	LCX072A0-4	72	170M3815	DIN1 ①	170M3063	1xTN/80	170M3213	1xTN/110	690	200	1
	LCX087A0-4	87	170M3815	DIN1 ①	170M3065	1xTN/80	170M3215	1xTN/110	690	200	1
	LCX105A0-4	105	170M3815	DIN1 ①	170M3065	1vTN/80	170M3215	1xTN/110	690	200	1
	LCX140A0-4	140	170M3819	DIN1 ①	170M3069	1xTN/80	170M3219	1xTN/110	690	400	1
CH5	LCX168A0-4	168	170M3819	DIN1 ①	170M3069	1xTN/80	170M3219	1xTN/110	690	400	1
	LCX208A0-4	208	170M3819	DIN1 ①	170M3069	1xTN/80	170M3219	1xTN/110	690	400	1
	LCX261A0-4	261	170M6808	DIN3	170M6058	3TN/80	170M6208	3TN/110	690	500	1
CH61	LCX300A0-4	300	170M6812	DIN3	170M6062	3TN/80	170M6212	3TN/110	690	800	1
	LCX385A0-4	385	170M6812	DIN3	170M6062	3TN/80	170M6212	3TN/110	690	800	1
CH62	LCX460A0-4	460	170M6814	DIN3	170M6064	3TN/80	170M6214	3TN/110	690	1000	1
	LCX520A0-4	520	170M6814	DIN3	170M6064	3TN/80	170M6214	3TN/110	690	1000	1
	LCX590A0-4	590	170M6812	DIN3	170M6062	3TN/80	170M6212	3TN/110	690	800	2
	LCX650A0-4	650	170M6812	DIN3	170M6062	3TN/80	170M6212	3TN/110	690	800	2
	LCX730A0-4	730	170M6812	DIN3	170M6062	3TN/80	170M6212	3TN/110	690	800	2
CH63	LCX820A0-4	820	170M6814	DIN3	170M6064	3TN/80	170M6214	3TN/110	690	1000	2
	LCX920A0-4	920	170M6814	DIN3	170M6064	3TN/80	170M6214	3TN/110	690	1000	2
	LCXH10A0-4	1030	170M6812	DIN3	170M6062	3TN/80	170M6212	3TN/110	690	800	3
	LCXH11A0-4	1150	170M6812	DIN3	170M6062	3TN/80	170M6212	3TN/110	690	800	3
CH64	LCXH13A0-4	1370	170M8547	3SHT ②	170M6066	3TN/80	170M6216	3TN/110	690	1250	3
	LCXH16A0-4	1640	170M8547	3SHT ②	170M6066	3TN/80	170M6216	3TN/110	690	1250	3
	LCXH20A0-4	2060	170M8550	3SHT ②	170M6069	3TN/80	170M6219	3TN/110	690	1600	3
	LCXH23A0-4	2300	170M8550	3SHT ②	170M6069	3TN/80	170M6219	3TN/110	690	1600	3

① T<sub>j</sub> = 77°F (25°C).

② SHT fuses can be assembled into DIN fuse base of the corresponding size.



**Table 3-8: Fuse Sizes for LCX9000 Liquid-Cooled (640 – 1100V) Inverters**

Chassis	Catalog Number	I <sub>th</sub> (A)	DIN43620		DIN43653 (110 mm)		Fuse U <sub>n</sub> (V)	Fuse I <sub>n</sub> (A)	Qty. of Fuses/ Poles
			aR Fuse	Fuse Size	aR Fuse	Fuse Size			
CH61	LCX170A0-5	170	170M4199	1SHT	170M4985	1TN/110	1250	400	1
	LCX208A0-5	208	170M4199	1SHT	170M4985	1TN/110	1250	400	1
	LCX261A0-5	261	170M6202	3SHT	170M8633	3TN/110	1250	500	1
CH62	LCX325A0-5	325	170M6305	3SHT	170M8636	3TN/110	1250	700	1
	LCX385A0-5	385	170M6305	3SHT	170M8636	3TN/110	1250	700	1
	LCX416A0-5	416	170M6277	3SHT	170M8639	3TN/110	1100	1000	1
	LCX460A0-5	460	170M6277	3SHT	170M8639	3TN/110	1100	1000	1
	LCX502A0-5	502	170M6277	3SHT	170M8639	3TN/110	1100	1000	1
CH63	LCX590A0-5	590	170M6305	3SHT	170M8636	3TN/110	1250	700	2
	LCX650A0-5	650	170M6305	3SHT	170M8636	3TN/110	1250	700	2
	LCX750A0-5	750	170M6305	3SHT	170M8636	3TN/110	1250	700	2
CH64	LCX820A0-5	820	170M6277	3SHT	170M8639	3TN/110	1100	1000	2
	LCX920A0-5	920	170M6277	3SHT	170M8639	3TN/110	1100	1000	2
	LCXH10A0-5	1030	170M6277	3SHT	170M8639	3TN/110	1250	700	3
	LCXH11A0-5	1180	170M6277	3SHT	170M8639	3TN/110	1100	1000	3
	LCXH13A0-5	1300	170M6277	3SHT	170M8639	3TN/110	1100	1000	3
	LCXH15A0-5	1500	170M6277	3SHT	170M8639	3TN/110	1100	1000	3
	LCXH17A0-5	1700	170M6277	3SHT	170M8639	3TN/110	1100	1000	3

**Note:** SHT fuses can be assembled into DIN fuse base of the corresponding size.

#### Fuse Information

Max fuse ambient temperature 122°F (50°C).

Fuse sizes can differ in the same chassis. Fuses can be chosen according to the highest current rating of the chassis to minimize fuse variants.

Check the current rating of the fuse bases according to the input current of the drive.

The physical size of the fuse is chosen on the basis of the fuse current: Current < 250 amps (size 1 fuse), current > 250 amps (size 3 fuse).



September 2007

**Fuse Sizes, Active Front End Units (AC Supply)**

**Table 3-9: Fuse Sizes for LCX9000 AFE Units (380 – 500V)**

Chassis	Catalog Number	I <sub>th</sub> (A)	DIN43620		DIN43653 (80 mm)		DIN43653 (110 mm)		Fuse U <sub>n</sub> (V)	Fuse I <sub>n</sub> (A)	Qty. of Fuses/Phase 3
			aR Fuse	Fuse Size	aR Fuse	Fuse Size	aR Fuse	Fuse Size			
CH3	LCX016A0-4	16	170M2679	DIN00	170M4828	00TN/80	—	—	1000	63	1
	LCX022A0-4	22	170M2679	DIN00	170M4828	00TN/80	—	—	1000	63	1
	LCX031A0-4	31	170M2679	DIN00	170M4828	00TN/80	—	—	1000	63	1
	LCX038A0-4	38	170M2679	DIN00	170M4828	00TN/80	—	—	1000	63	1
	LCX045A0-4	45	170M2683	DIN00	170M4832	00TN/80	—	—	1000	160	1
	LCX061A0-4	61	170M2683	DIN00	170M4832	00TN/80	—	—	1000	160	1
CH4	LCX072A0-4	72	170M2683	DIN00	170M4832	00TN/80	—	—	1000	160	1
	LCX087A0-4	87	170M2683	DIN00	170M4832	00TN/80	—	—	1000	160	1
	LCX105A0-4	105	170M2683	DIN00	170M4832	00TN/80	—	—	1000	160	1
	LCX140A0-4	140	170M4199	1SHT	—	—	170M4985	1TN/110	1250	400	1
CH5	LCX168A0-4	168	170M4199	1SHT	—	—	170M4985	1TN/110	1250	400	1
	LCX208A0-4	208	170M4199	1SHT	—	—	170M4985	1TN/110	1250	400	1
	LCX261A0-4	261	170M4199	1SHT	—	—	170M4985	1TN/110	1250	400	1
CH61	LCX300A0-4	300	170M6202	3SHT	—	—	170M8633	3TN/110	1250	500	1
	LCX385A0-4	385	170M6305	3SHT	—	—	170M8636	3TN/110	1250	700	1
CH62	LCX460A0-4	460	170M6277	3SHT	—	—	170M8639	3TN/110	1100	1000	1
	LCX520A0-4	520	170M6277	3SHT	—	—	170M8639	3TN/110	1100	1000	1
	LCX590A0-4	590	170M6277	3SHT	—	—	170M8639	3TN/110	1100	1000	1
	LCX650A0-4	650	170M6305	3SHT	—	—	170M8636	3TN/110	1250	700	2
	LCX730A0-4	730	170M6305	3SHT	—	—	170M8636	3TN/110	1250	700	2
CH63	LCX820A0-4	820	170M6305	3SHT	—	—	170M8636	3TN/110	1250	700	2
	LCX920A0-4	920	170M6277	3SHT	—	—	170M8639	3TN/110	1100	1000	2
	LCXH10A0-4	1030	170M6277	3SHT	—	—	170M8639	3TN/110	1100	1000	2
	LCXH11A0-4	1150	170M6277	3SHT	—	—	170M8639	3TN/110	1100	1000	2
CH64	LCXH13A0-4	1370	170M6277	3SHT	—	—	170M8639	3TN/110	1100	1000	3
	LCXH16A0-4	1640	170M6277	3SHT	—	—	170M8639	3TN/110	1100	1000	3
	LCXH20A0-4	2060	170M6277	3SHT	—	—	170M8639	3TN/110	1100	1000	4
	LCXH23A0-4	2300	170M6277	3SHT	—	—	170M8639	3TN/110	1100	1000	4

**Table 3-10: Fuse Sizes for LCX9000 AFE Units (525 – 690V)**

Chassis	Catalog Number	I <sub>th</sub> (A)	DIN43620		DIN43653 (110 mm)		Fuse U <sub>n</sub> (V)	Fuse I <sub>n</sub> (A)	Qty. of Fuses/Phase 3
			aR Fuse	Fuse Size	aR Fuse	Fuse Size			
CH61	LCX170A0-5	170	170M4199	1SHT	170M4985	1TN/110	1250	400	1
	LCX0208A0-5	208	170M4199	1SHT	170M4985	1TN/110	1250	400	1
	LCX0261A0-5	261	170M4199	1SHT	170M4985	1TN/110	1250	400	1
CH62	LCX0325A0-5	325	170M6305	3SHT	170M8636	3TN/110	1250	700	1
	LCX0385A0-5	385	170M6305	3SHT	170M8636	3TN/110	1250	700	1
	LCX0416A0-5	416	170M6305	3SHT	170M8636	3TN/110	1250	700	1
	LCX0460A0-5	460	170M6277	3SHT	170M8639	3TN/110	1100	1000	1
	LCX0502A0-5	502	170M6277	3SHT	170M8639	3TN/110	1100	1000	1
CH63	LCX0590A0-5	590	170M6277	3SHT	170M8639	3TN/110	1100	1000	1
	LCX0650A0-5	650	170M6305	3SHT	170M8636	3TN/110	1250	700	2
	LCX0750A0-5	750	170M6305	3SHT	170M8636	3TN/110	1250	700	2
CH64	LCX0820A0-5	820	170M6305	3SHT	170M8636	3TN/110	1250	700	2
	LCX0920A0-5	920	170M6277	3SHT	170M8639	3TN/110	1100	1000	2
	—	—	—	—	170M8639	3TN/110	1100	1000	2
	—	—	—	—	170M8639	3TN/110	1100	1000	2
	LCXH13A0-5	1300	170M6305	3SHT	170M8636	3TN/110	1250	700	3
	LCXH15A0-5	1500	170M6277	3SHT	170M8639	3TN/110	1100	1000	3

**Note:** SHT fuses can be assembled into DIN fuse base of the corresponding size.

## Cable Installation Instructions

1. Before starting the installation, check that none of the components of the drive is live.
2. LCX9000 Liquid-Cooled drive must always be installed in an enclosure, a separate cubicle or an electrical room.

Always use a jib crane or similar lifting device to lift the drive. For safe and appropriate lifting, see **Page 2-1**.

3. Place the motor cables far enough from other cables:
  - **Avoid placing** the motor cables in long parallel lines with other cables.
  - If the motor cables run in parallel with other cables, note the **minimum distances** between the motor cables and other cables given in table below.
  - The given distances also apply between the motor cables and signal cables of other systems.

Distance between Parallel Running Cables in Feet (m)	Shielded Cable in Feet (m)
10 (.3)	≤164 (50)
3.3 (1.0)	≤656 (200)

- **The maximum length of the motor cables is 984 feet (300m).**
  - **The motor cables should cross** other cables at an angle of 90 degrees.
4. If **cable insulation checks** are needed, see **Page 3-14**.

September 2007

## 5. Connect the cables:

- For chassis CH5 and greater, an external flexible cable connection block must be used at both mains and motor ends if stiff cable type (EMCMK, MCMK) is used. See **Page 3-1**.
- Strip the cables at a sufficient distance if needed.
- **Connect the mains, motor and control cables** to their respective terminals (see **Chapter 2**). If busbar connection is used, bolt the bars and the terminals together. See bolt sizes on **Pages 2-2 to 2-11**.
- Also take the maximum terminal stresses shown in **Figure 3-1** into account.
- For information on **cable installation according to UL regulations** see **Page 3-13**.
- Make sure that the control cable wires do not come in contact with the electronic components of the unit.
- If an **external brake resistor** (option) is used, connect its cable to the appropriate terminal (CH3 only).
- **Check the connection** of the ground cable to the motor and the drive terminals marked with ⚡.
- Connect the **separate shield of the power cable** to the ground terminals of the drive, motor and the supply center.

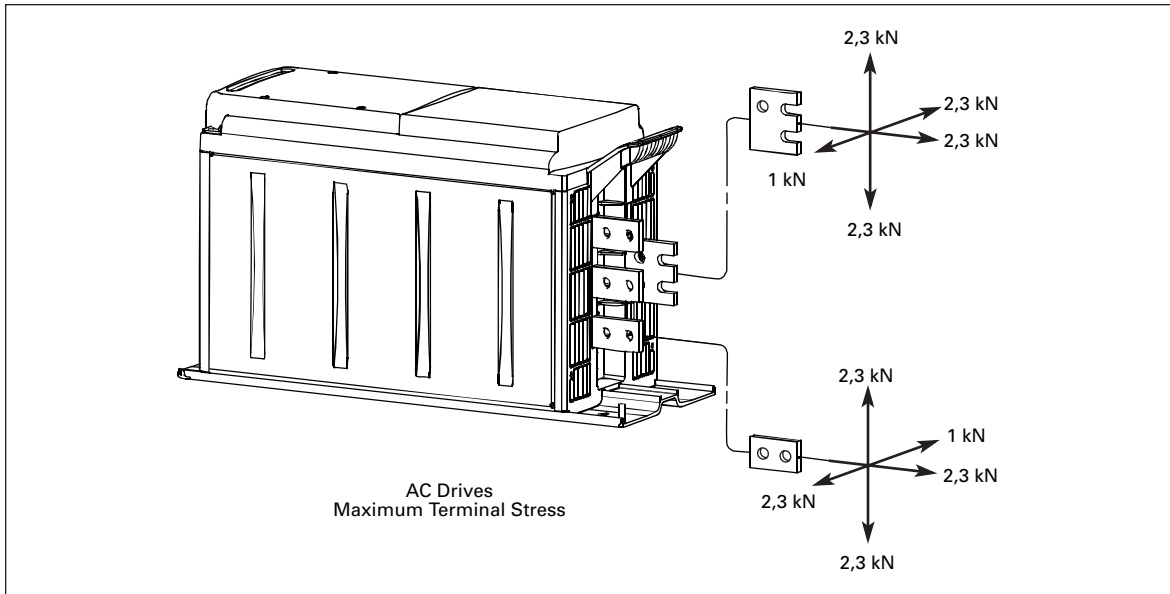
## 6. Liquid cooling connection:

The standard delivery of the LCX9000 Liquid-Cooled drive includes hoses on the cooling element 4.9 feet (1.5m) in length and .59 inches (15 mm) in diameter. The hoses are inserted in 55 inch (1400 mm) UL94V0 approved conduits. Connect the line hose branch to its counterpart (screw or fast connector) of the Cutler-Hammer Liquid-Cooled drive.

Due to high pressure in the line hose, equipping the liquid line with a shut-off valve is recommended, which makes the connection easier. In order to prevent water from spraying in the installation room we also recommend wrapping e.g. linters around the connection during installation. For more information on the liquid connection, see **Page 2-18**.

When the installation in the enclosure is completed, the liquid pump can be started. See Start-Up of the drive in **Chapter 6**.

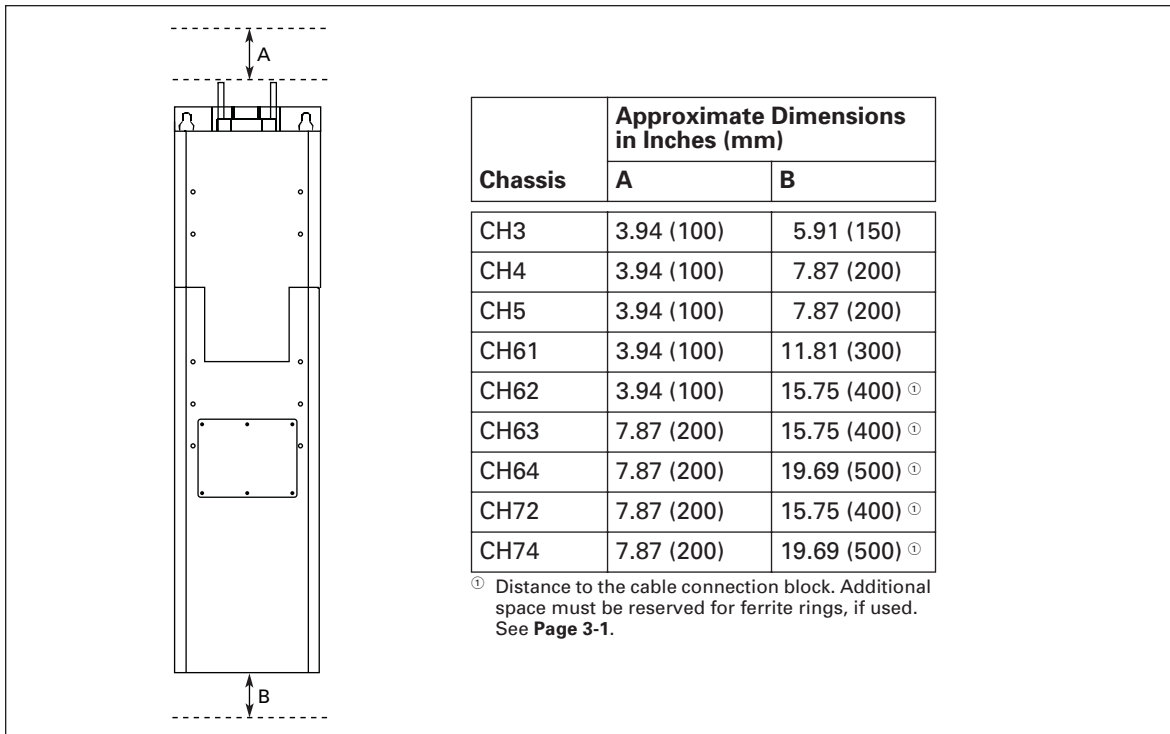
**Note:** Do not switch on the power before ensuring proper function of the liquid cooling system.



**Figure 3-1: Maximum Terminal Stresses**

### Installation Space

Enough free space must be left above and below the drive to ensure practical and appropriate electrical and cooling connections. The minimum dimensions are given in the table below. No space is required to the left and right of the drive.



**Figure 3-2: Installation Space**

September 2007

## Grounding of Power Unit

The mains cables are connected to the protective ground of the switchgear enclosure.

We recommend connecting the motor cables to the common PE of the cabinet/cabinet system.

For grounding of the drive itself, use the grounding terminal on the drive mounting plate (see **Figure 3-3**).



**Figure 3-3: Grounding Terminal on Mounting Plate**

## Cable Installation and the UL Standards

To meet the UL (Underwriters Laboratories) regulations, a UL-approved copper cable with a minimum heat resistance of +140/167°F (+60/75°C) must be used.

The tightening torques of the terminals are given in **Table 3-4**.

## Cable and Motor Insulation Checks

### 1. Motor cable insulation checks

Disconnect the motor cable from terminals U, V and W of the drive and from the motor. Measure the insulation resistance of the motor cable between each phase conductor as well as between each phase conductor and the protective ground conductor.

The insulation resistance must be at least 1 – 2M $\Omega$ .

### 2. Mains cable insulation checks

Disconnect the mains cable from terminals L1, L2 and L3 of the drive and from the mains. Measure the insulation resistance of the mains cable between each phase conductor as well as between each phase conductor and the protective ground conductor.

The insulation resistance must be at least 1 – 2M $\Omega$ .

### 3. Motor insulation checks

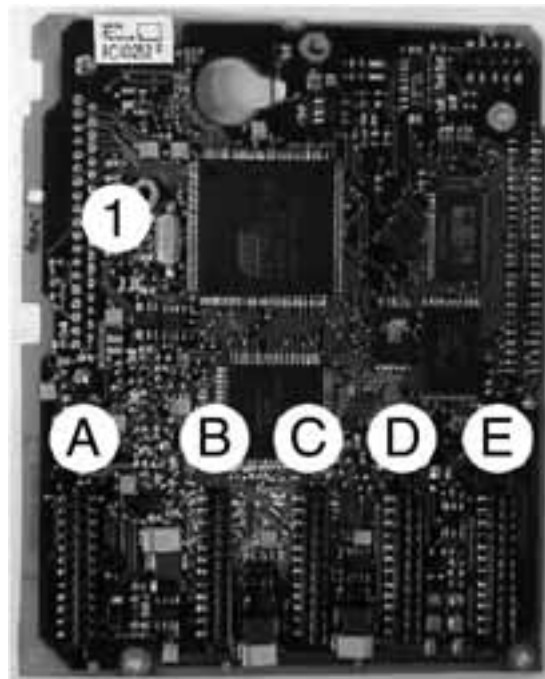
Disconnect the motor cable from the motor and open the bridging connections in the motor connection box. Measure the insulation resistance of each motor winding. The measurement voltage must equal at least the motor nominal voltage but not exceed 1000V. The insulation resistance must be at least 1 – 2M $\Omega$ .

September 2007

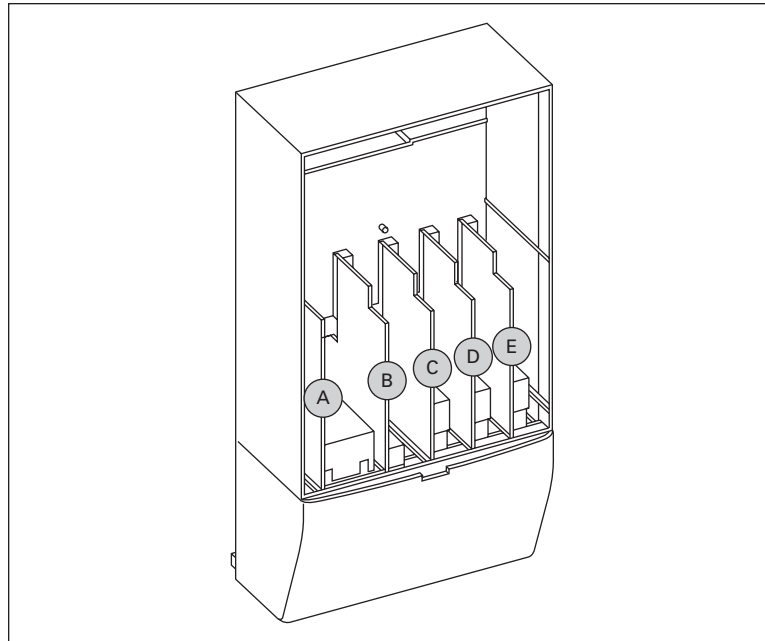
## Chapter 4 — Control Wiring and Internal Connections

The control unit of the Cutler-Hammer Liquid-Cooled drive is installed into a mounting box. It contains the control board and additional boards (see **Figures 4-1** and **4-2**) connected to the five slot connectors (A to E) of the control board. The control unit and the ASIC of the power unit are connected through cables (and an adapter board). For more information, see **Page 4-17**.

The mounting box with the control unit is mounted inside an enclosure. See the mounting instructions on **Page 4-10**.



**Figure 4-1: Control Board**

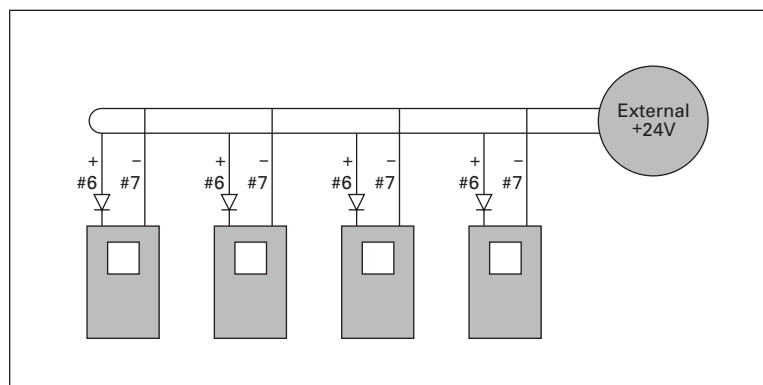


**Figure 4-2: Basic and Option Board Connections of the Control Board**

Usually, when the drive is delivered from the factory, the control unit includes at least the standard compilation of two basic boards (I/O board and relay board) which are normally installed in slots A and B. On the next pages you will find the arrangement of the control I/O and the relay terminals of the two basic boards, the general wiring diagram and the control signal descriptions. The I/O boards mounted at the factory are indicated in the catalog number.

The control board can be powered externally (+24V,  $\pm 10\%$ ) by connecting the external power source to either of the bidirectional terminals, #6 or #12, see **Page 4-7**. This voltage is sufficient for parameter setting and for keeping the fieldbus active.

**Note:** If the 24V inputs of several drives are parallel connected, we recommend using a diode in terminal #6 (or #12) in order to avoid the current flowing in opposite directions. This might damage the control board. See **Figure 4-3**.



**Figure 4-3: Drives Connected in Parallel**



September 2007

## Control Board Power-Up

The control board can be powered (+24V) in two different ways: either 1) directly from the power board ASIC, terminal X10; or 2) externally using the customer's own power source. This voltage is sufficient for parameter setting and for keeping the fieldbus active.

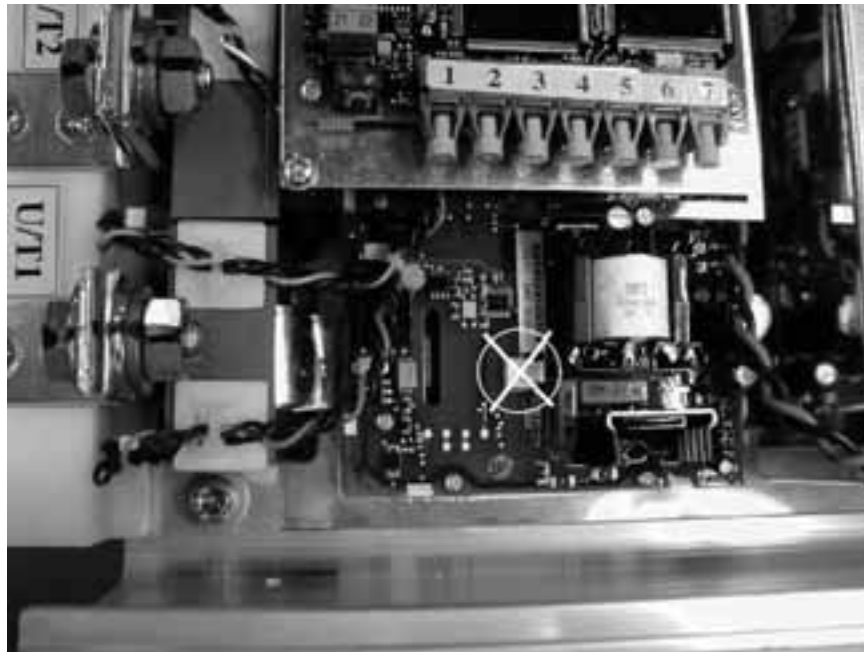
By factory default, the control unit is powered using the terminal X10 on the power board. However, if an external supply is used to power up the control unit, a load resistor must be connected to terminal X10 on the power board. This applies to all chassis  $\geq$ CH61.

---

### Notice

---

**IMPORTANT NOTE FOR CHASSIS CH3, CH4 and CH5:** If you power the control board from the power board be sure to connect the cable to the correct terminal. Terminal J2 on the power board is reserved for this purpose. Do not connect the cable to terminal J1. See **Figures 4-4** and **4-5**.



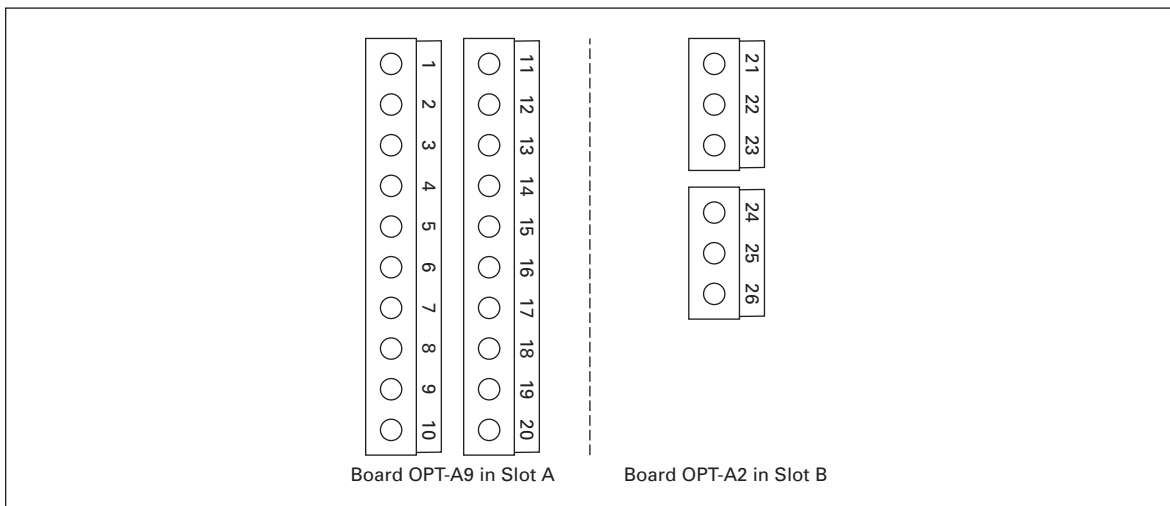
**Figure 4-4: Connection of Control Board Cable from the Power Board  
WRONG: Terminal J1 (Upper)**



**Figure 4-5: Connection of Control Board Cable from the Power Board  
CORRECT: Terminal J2 (Lower)**

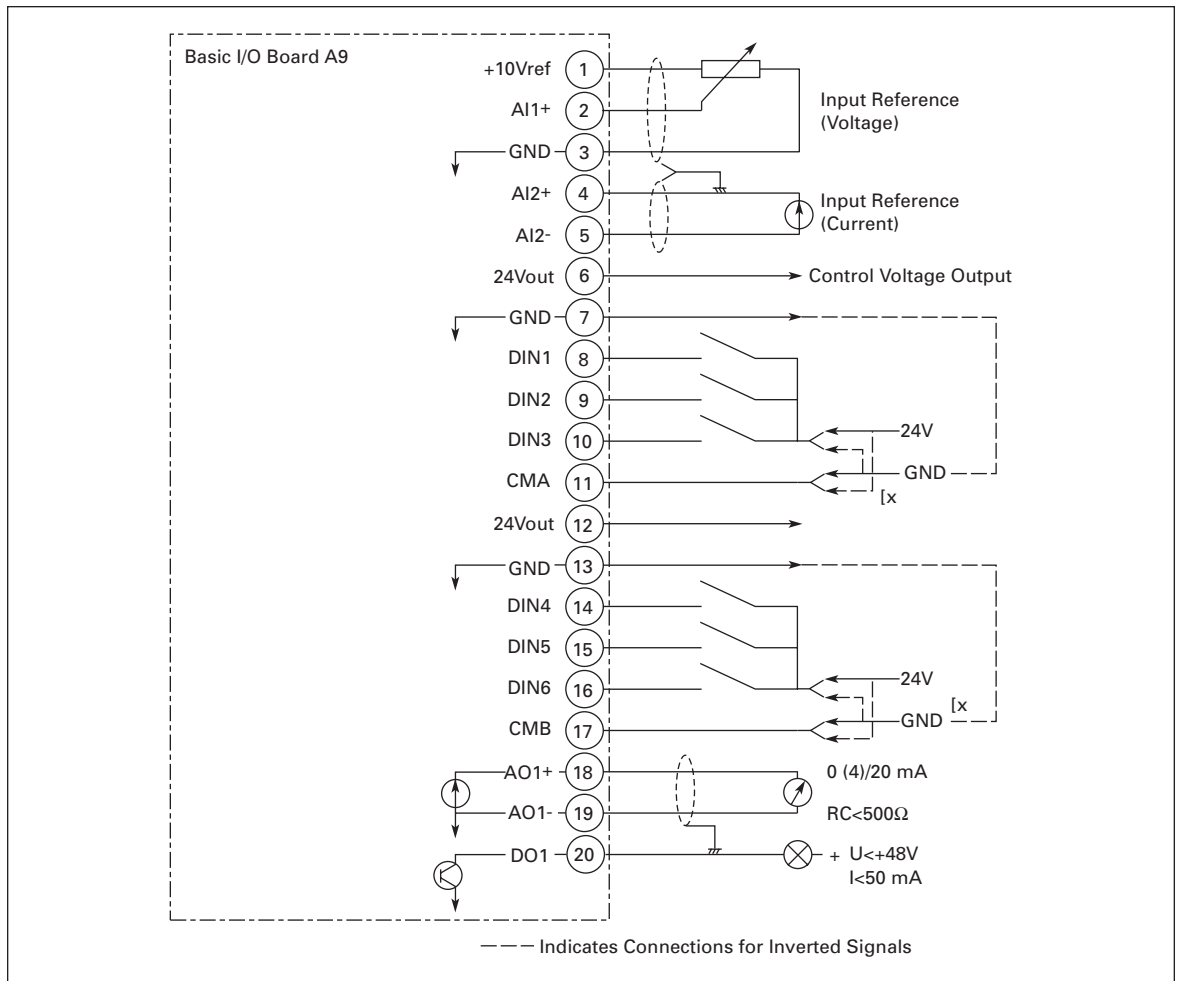
### Control Connections

The basic control connections for boards A9 and A2 are shown in **Table 4-1** on **Page 4-7**. The signal descriptions are presented in the application manual.

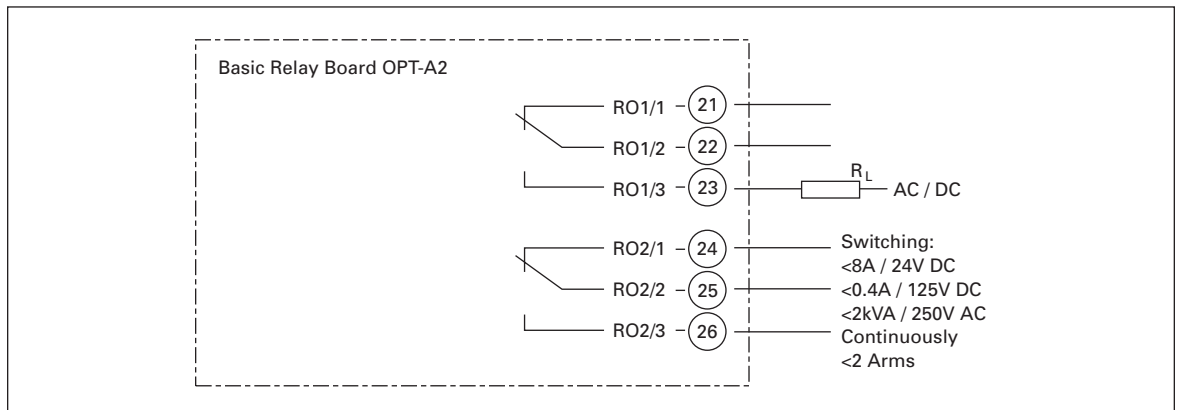


**Figure 4-6: I/O Terminals of the Two Basic Boards**

September 2007



**Figure 4-7: General Wiring Diagram of the Basic I/O Board (OPT-A9)**



**Figure 4-8: General Wiring Diagram of the Basic Relay Board (OPT-A2)**

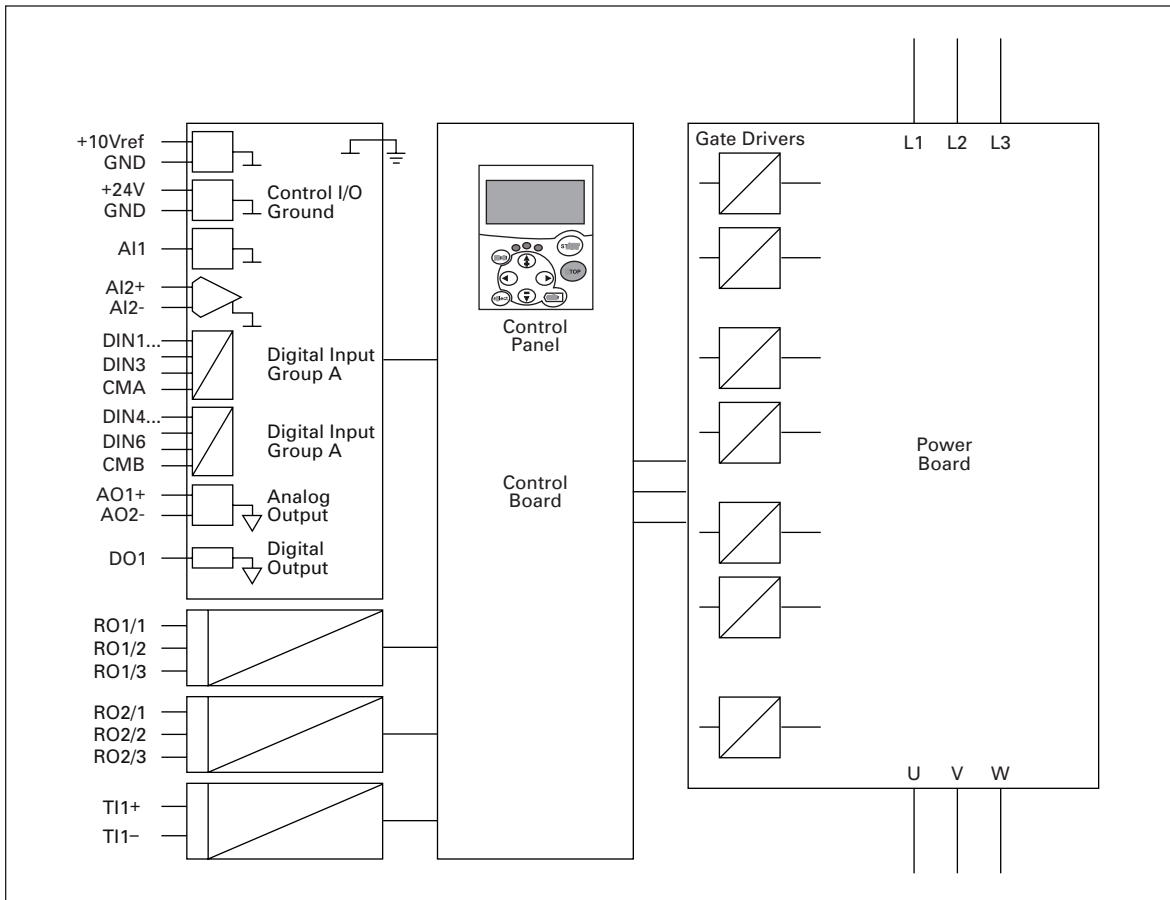
**Control Cables**

The control cables should be at least 20 AWG (.5 mm<sup>2</sup>) screened multicore cables, see **Table 3-1**. The maximum terminal wire size is 14 AWG (2.5 mm<sup>2</sup>) for the relay terminals and 16 AWG (1.5 mm<sup>2</sup>) for other terminals.

**Galvanic Isolation Barriers**

The control connections are isolated from the mains potential and the GND terminals are permanently connected to ground. See **Figure 4-9**.

The digital inputs are galvanically isolated from the I/O ground. The relay outputs are additionally double-isolated from each other at 300V AC (EN-50178).

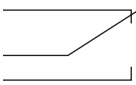
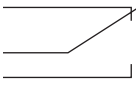


**Figure 4-9: Galvanic Isolation Barriers**

September 2007

## Control Terminal Signals

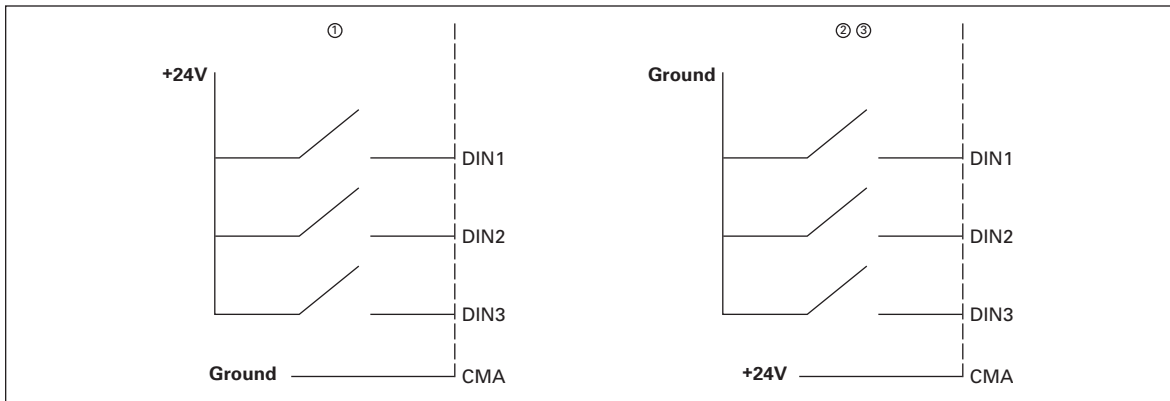
**Table 4-1: Control I/O Terminal Signals**

Terminal	Signal	Technical Information		
<b>OPT-A9</b>				
1	+10 V <sub>ref</sub>	Reference voltage Maximum current 10 mA		
2	AI1+	Analog input, voltage or current Selection V or mA with jumper block X1 (see <b>Page 4-9</b> ): Default: 0 to +10V (R <sub>i</sub> = 200 kΩ) (-10V to 10V Joystick control, selected with a jumper) 0 – 20 mA (R <sub>i</sub> = 250 Ω)		
3	GND/AI1–	Analog input common Differential input if not connected to ground; Allows ±20V differential mode voltage to GND		
4	AI2+	Analog input, voltage or current Selection V or mA with jumper block X2 (see <b>Page 4-9</b> ): Default: 0 – 20 mA (R <sub>i</sub> = 250 kΩ) 0 – 10V (R <sub>i</sub> = 200 kΩ) (-10V to 10V Joystick control, selected with a jumper)		
5	GND/AI2–	Analog input common Differential input if not connected to ground; Allows ±20V differential mode voltage to GND		
6	24 V <sub>out</sub> (bidirectional)	24V auxiliary voltage ±15%, maximum current 250 mA Can also be used as external power backup for the control unit (and fieldbus)		
7	GND	I/O ground Ground for reference and controls		
8	DIN1	Digital input 1		
9	DIN2	Digital input 2		
10	DIN3	Digital input 3		
11	CMA	Digital input common A for DIN1, DIN2 and DIN3 Must be connected to GND or 24V of I/O terminal or to external 24V or GND Selection with jumper block X3 (see <b>Page 4-9</b> ):		
12	24 V <sub>out</sub> (bidirectional)	24V auxiliary voltage Same as terminal #6		
13	GND	I/O ground Same as terminal #7		
14	DIB4	Digital input 4		
15	DIB5	Digital input 5		
16	DIB6	Digital input 6		
17	CMB	Digital input common B for DIB4, DIB5 and DIB6 Must be connected to GND or 24V of I/O terminal or to external 24V or GND Selection with jumper block X3 (see <b>Page 4-9</b> ):		
18	AO1+	Analog signal (+output)		
19	AO1–	Analog output common Output signal range: Current 0(4) – 20 mA, R <sub>L</sub> max 500Ω or Voltage 0 – 10V, R <sub>L</sub> >1kΩ Selection with jumper block X6 (see <b>Page 4-9</b> ):		
20	DO1	Open collector output Maximum U <sub>in</sub> = 48V DC Maximum current = 50 mA		
<b>OPT-A2</b>				
21	RO1/1	 Relay output 1	Max. switching voltage	250V AC, 125V DC
22	RO1/2		Max. switching current	8A/24V DC, 0.4A/250V DC
23	RO1/3		Min. switching load	5V/10 mA
24	RO2/1	 Relay output 2	Max. switching voltage	250V AC, 125V DC
25	RO2/2		Max. switching current	8A/24V DC, 0.4A/250V DC
26	RO2/3		Min. switching load	5V/10 mA

**Digital Input Signal Inversions**

The active signal level depends on which potential the common inputs CMA and CMB (terminals 11 and 17) are connected to. The alternatives are either +24V or ground (0V). See **Figure 4-10**.

The 24V control voltage and the ground for the digital inputs and the common inputs (CMA, CMB) can be either internal or external.



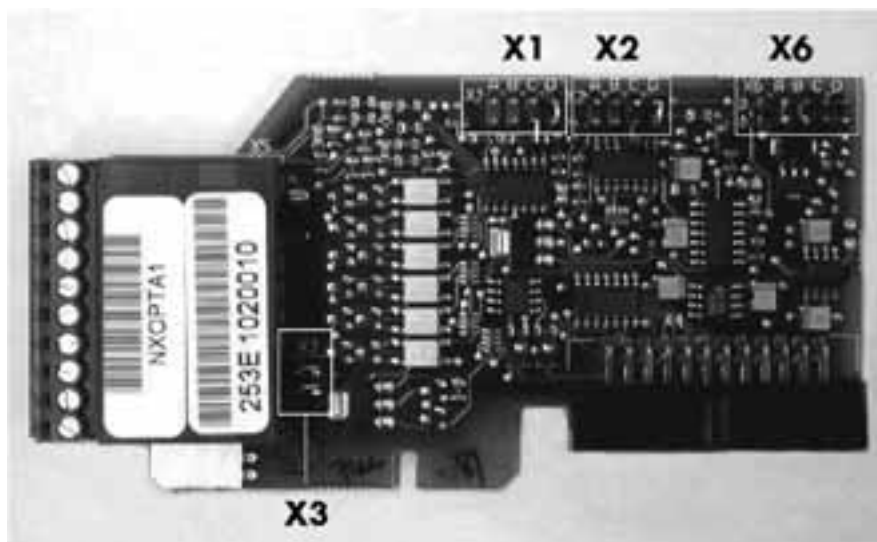
**Figure 4-10: Positive/Negative Logic**

- ① Positive logic (+24V is the active signal) = the input is active when the switch is closed.
- ② Negative logic (0V is the active signal) = the input is active when the switch is closed.
- ③ Requires setting of jumper X3 to position "CMA/CMB isolated from ground."

**Jumper Selections on the OPT-A9 Basic Board**

The user is able to customize the functions of the drive to better suit his needs by selecting certain positions for the jumpers on the OPT-A9 board. The positions of the jumpers determine the signal type of analogue and digital inputs.

On the A9 basic board, there are four jumper blocks X1, X2, X3 and X6 each containing eight pins and two jumpers. The selectable positions of the jumpers are shown in **Figure 4-12**.



**Figure 4-11: Jumper Blocks on OPT-A9**

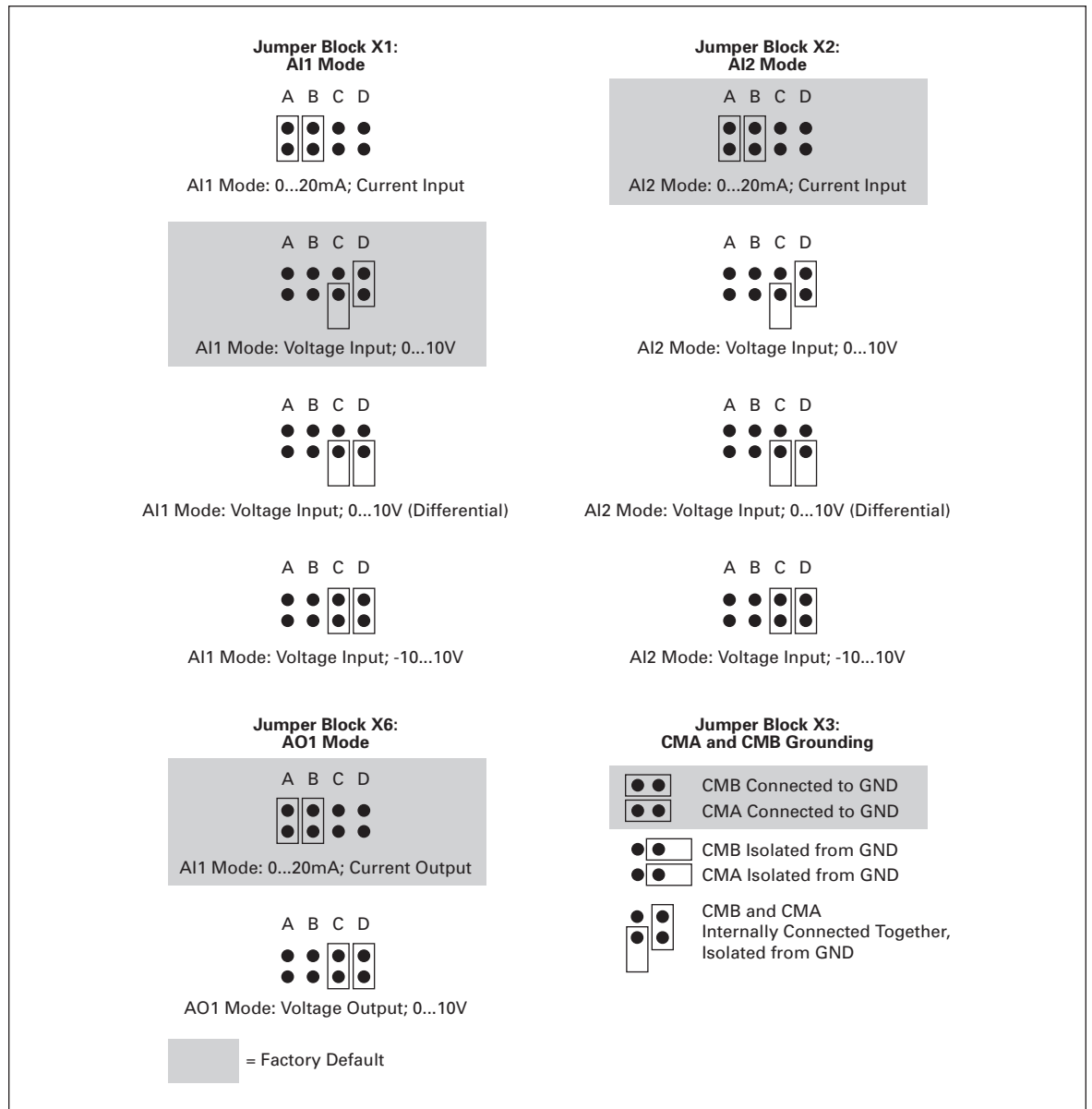
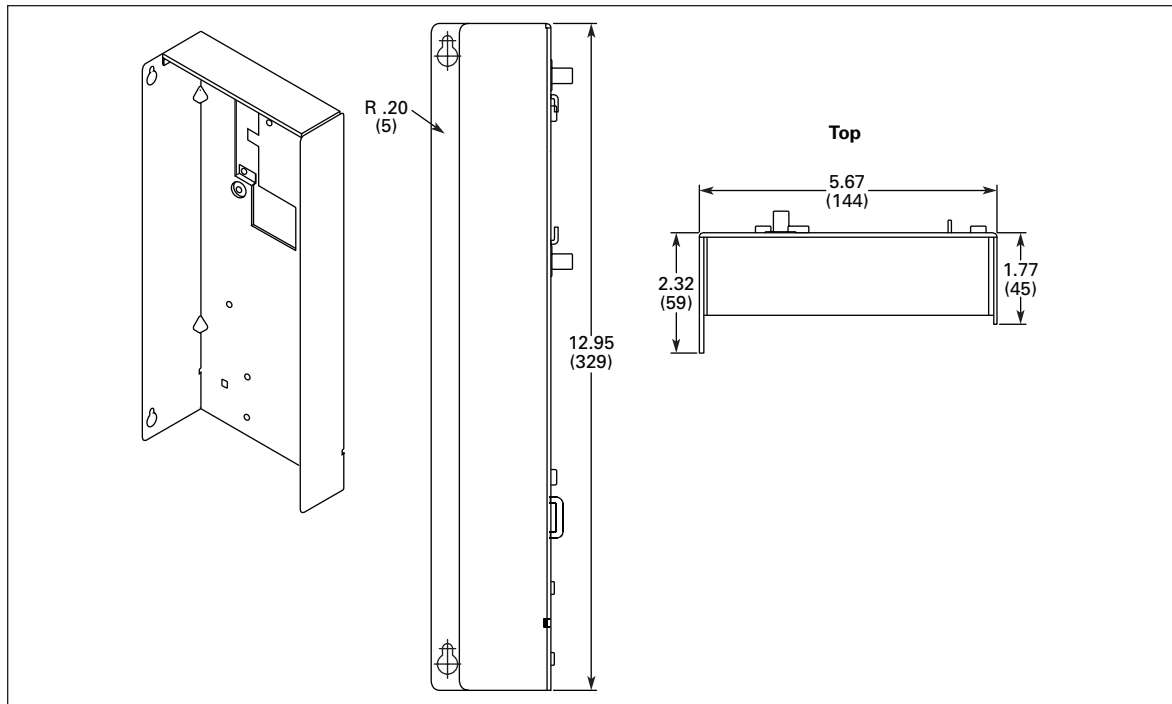


Figure 4-12: Jumper Selection for OPT-A9

**Note:** If you change the AI signal content also remember to change the corresponding board parameter in menu M7.

## Control Unit Mounting Box



**Figure 4-13: Control Unit Mounting Box**

*Approximate Dimensions in Inches (mm)*

### **Installing the Control Unit Mounting Box**

The control unit of the LCX9000 Liquid-Cooled drive is mounted into a metal box which then can be placed inside the enclosure. The keypad can be used to control the drive. The keypad is connected to the control unit with an RS-232 cable and mounted on the enclosure door. Pay special attention to the grounding of the cable, see instructions below.







**Figure 4-14: Control Unit Installed into the Mounting Box;  
Left: Front; Right: Back**



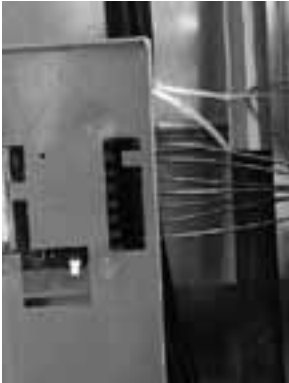


September 2007

**Table 4-2: Installing the Control Unit Mounting Box**



<ol style="list-style-type: none"><li>1. If the keypad sits in its place on the control unit, remove the keypad.</li><li>2. Connect the male end of the keypad cable to the D-connector of the control unit. Use RS-232 cable included in the delivery.</li></ol>	
<ol style="list-style-type: none"><li>3. Run the cable over the top of the box and secure with plastic band on the backside.</li></ol>	
<ol style="list-style-type: none"><li>4. Grounding of keypad cable: Ground the keypad cable in the mounting box frame by fixing the branch cable with a screw underneath the control unit.</li></ol>	
	

**Table 4-2: Installing the Control Unit Mounting Box (Continued)**

<p>5. Mount the control unit mounting box in the front-left corner of the enclosure using two screws.</p> <p><b>Note:</b> Do not install the mounting box floating (with e.g. plastic screws).</p>	
<p>6. Connect the optical cables (or the flat cable) to the power unit. See <b>Page 4-17</b>.</p>	
	

September 2007

**Table 4-2: Installing the Control Unit Mounting Box (Continued)**

7. Connect the female end of the keypad cable to keypad on the enclosure door.	
8. Use a cable channel for the cable run.	

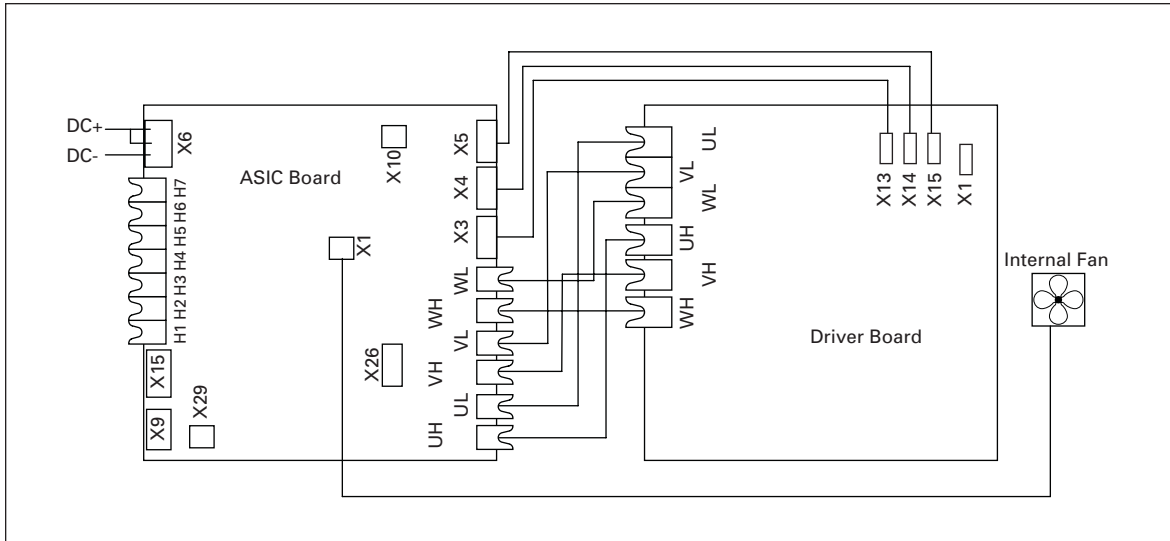
## Internal Connections

As a general rule, all internal electrical and communications connections are made at the factory. However, if modules have to be moved, for example, and the connections therefore removed, you will have to re-establish the connections between 1) the Power Unit ASIC and the Driver Board(s) on the one hand and 2) the Power Unit ASIC and the Optical Cable Adapter Board on the other.

### ***Connections between Power Unit ASIC and Driver Boards***

See the figures and tables on the following pages for the correct connection of internal electrical and communications connections.

**Note:** The minimum optical cable bending radius is 1.97 inches (50 mm).

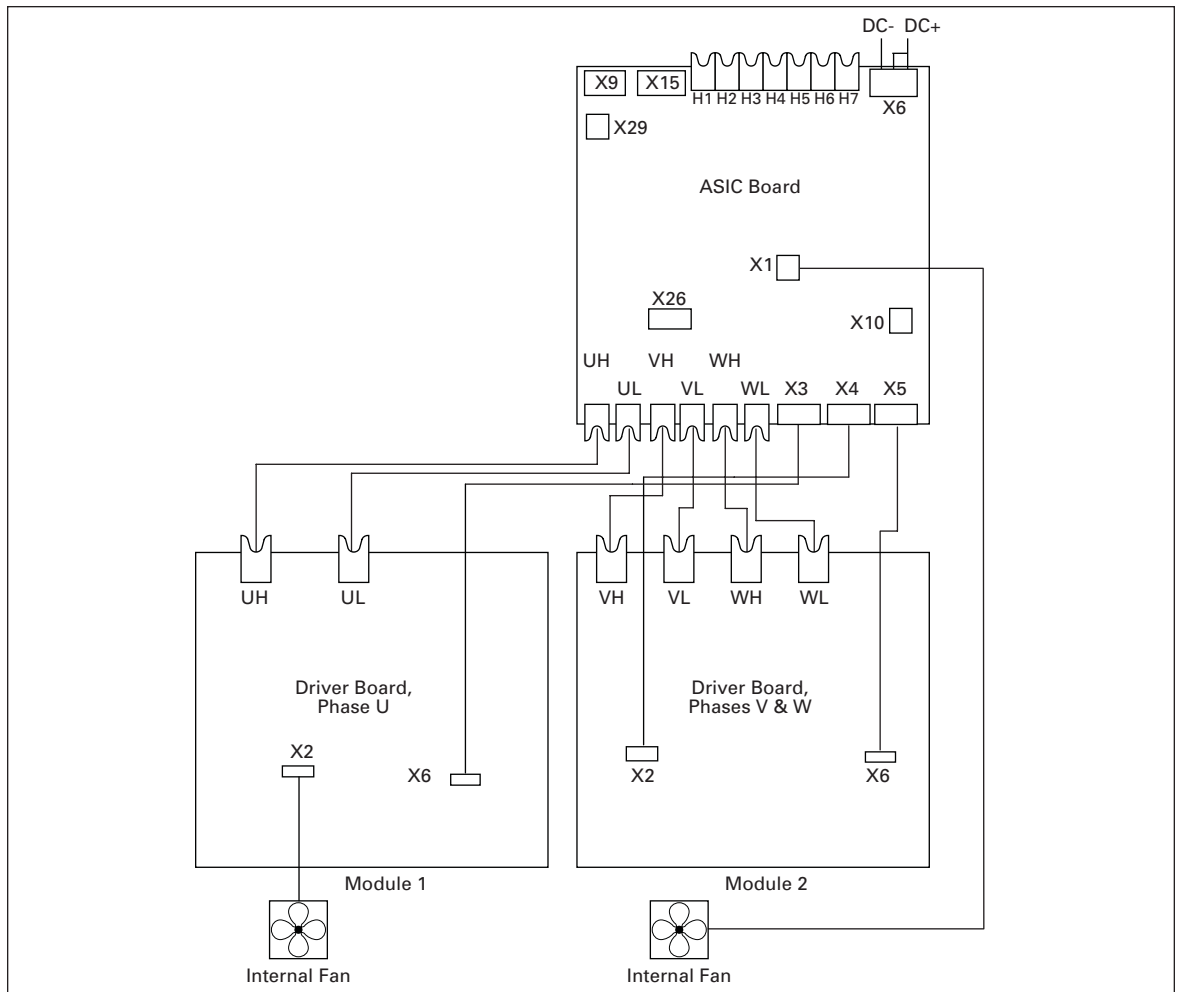


**Figure 4-15: Terminals and Connections between ASIC and Driver Board (CH61, CH62 and CH72)**

**Table 4-3: Terminals (CH61, CH62 and CH72)**

Terminal	Description	Terminal	Description
<b>Terminals on ASIC Board</b>		<b>Terminals on ASIC Board (Continued)</b>	
X9	OEVA feedback	UH	Connect to UH on driver board
X15	Charging relay output	UL	Connect to UL on driver board
X6	DC terminal	VH	Connect to VH on driver board
X29	Flow supervision input	VL	Connect to VL on driver board
X26	Star Coupler terminal for drives greater than CH61	WH	Connect to WH on driver board
X10	+24V to control board	WL	Connect to WL on driver board
X3	Connect to terminal X13 on driver board	<b>Terminal X1 on Driver Board</b>	
X4	Connect to terminal X14 on driver board	X1	DC terminal
X5	Connect to terminal X15 on driver board		
X1	Driver board fan power connection		

September 2007

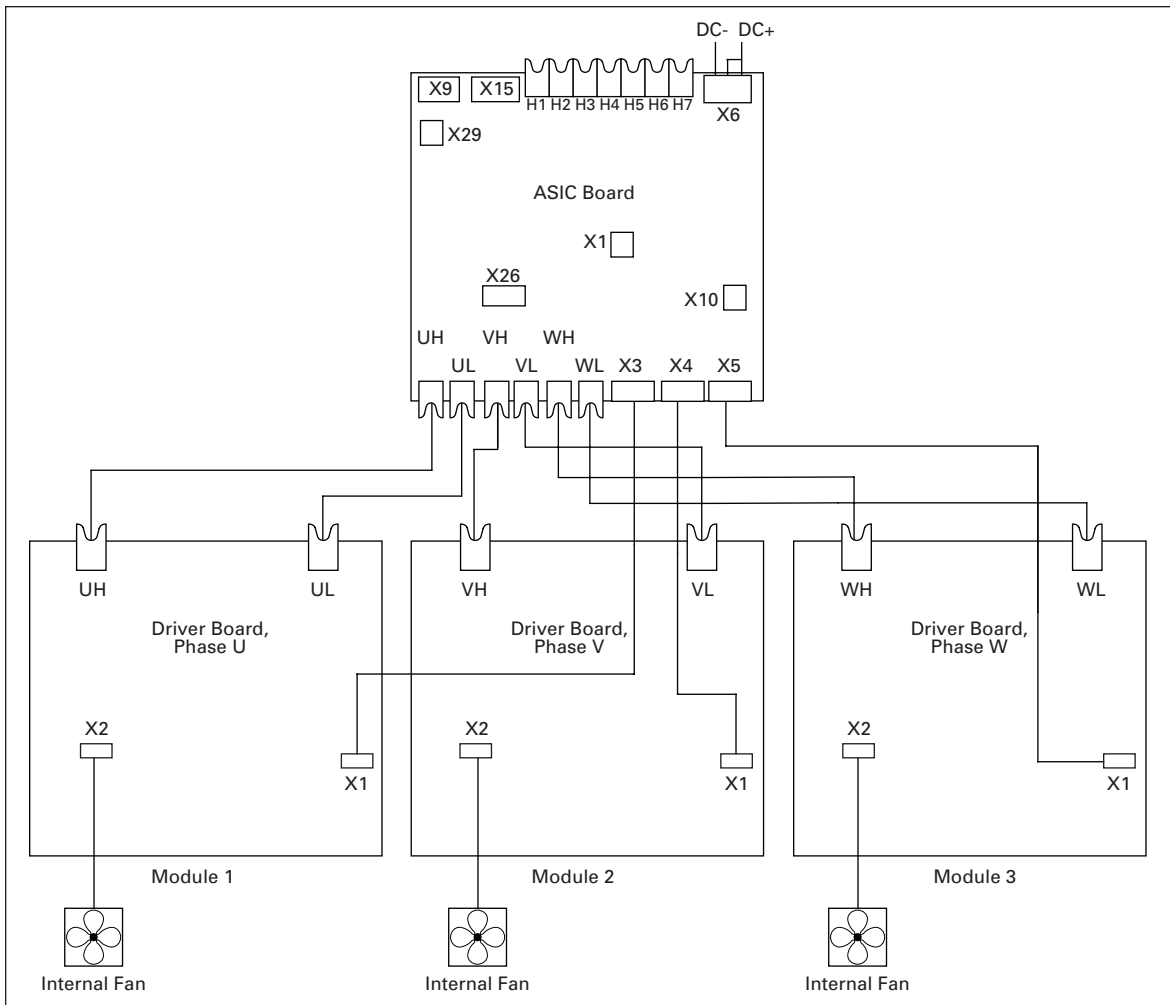


**Figure 4-16: Terminals and Connections between ASIC and Driver Board (CH63)**

**Table 4-4: Terminals (CH63)**

Terminal	Description
<b>Terminals on ASIC Board</b>	
X9	OEVA feedback
X15	Charging relay output
X6	DC terminal
X29	Flow supervision input
X26	Star Coupler terminal for drives greater than CH61
X10	+24V to control board
X3	Connect to terminal X6 on phase U driver board
X4	Connect to terminal X2 on phase V/W driver board
X5	Connect to terminal X6 on phase V/W driver board
X1	Internal fan power connection for Mod. 2

Terminal	Description
<b>Terminals on ASIC Board (Continued)</b>	
UH	Connect to UH on Phase U driver board
UL	Connect to UL on Phase U driver board
VH	Connect to VH on Phase V/W driver board
VL	Connect to VL on Phase V/W driver board
WH	Connect to WH on Phase V/W driver board
WL	Connect to WL on Phase V/W driver board
<b>Terminal X2 on Phase U Driver Board</b>	
X2	Internal fan power connection for Mod. 1



**Figure 4-17: Terminals and Connections between ASIC and Driver Boards (CH64 and CH74)**

**Table 4-5: Terminals between Driver Boards (CH64 and CH74)**

Terminal	Description	Terminal	Description
<b>Terminals on ASIC Board</b>		<b>Terminals on ASIC Board (Continued)</b>	
<b>X9</b>	OEVA feedback	<b>UH</b>	Connect to UH on Phase U driver board
<b>X15</b>	Charging relay output	<b>UL</b>	Connect to UL on Phase U driver board
<b>X6</b>	DC terminal	<b>VH</b>	Connect to VH on Phase V driver board
<b>X29</b>	Flow supervision input	<b>VL</b>	Connect to VL on Phase V driver board
<b>X26</b>	Star Coupler terminal for drives greater than CH61	<b>WH</b>	Connect to WH on Phase W driver board
<b>X10</b>	+24V to control board	<b>WL</b>	Connect to WL on Phase W driver board
<b>X3</b>	Connect to terminal X1 on phase U driver board	<b>Terminal X2 on Phase Driver Boards</b>	
<b>X4</b>	Connect to terminal X1 on phase V driver board	<b>X2</b>	Internal fan power connection
<b>X5</b>	Connect to terminal X1 on phase W driver board		

September 2007

### **Connections between Power Unit ASIC and the Control Unit**

The communication connections between the liquid-cooled drive power unit and the control unit (see **Page 6-1**) can be established using either the conventional round cable (standard in chassis CH3, CH4 and CH5) or optical cable (all chassis). Note that for chassis CH61 and larger, only optical cables can be used.

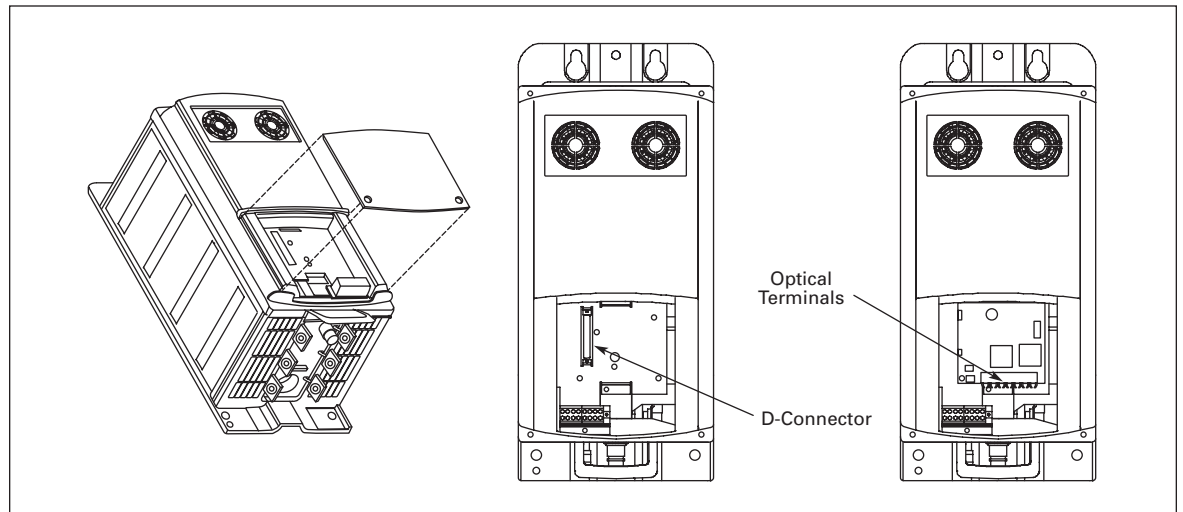
#### **Connections with Round Cable**

The communication connection between the drive power unit and the control unit in chassis CH3, CH4 and CH5 are primarily made with conventional round cable and D-connectors at both ends.

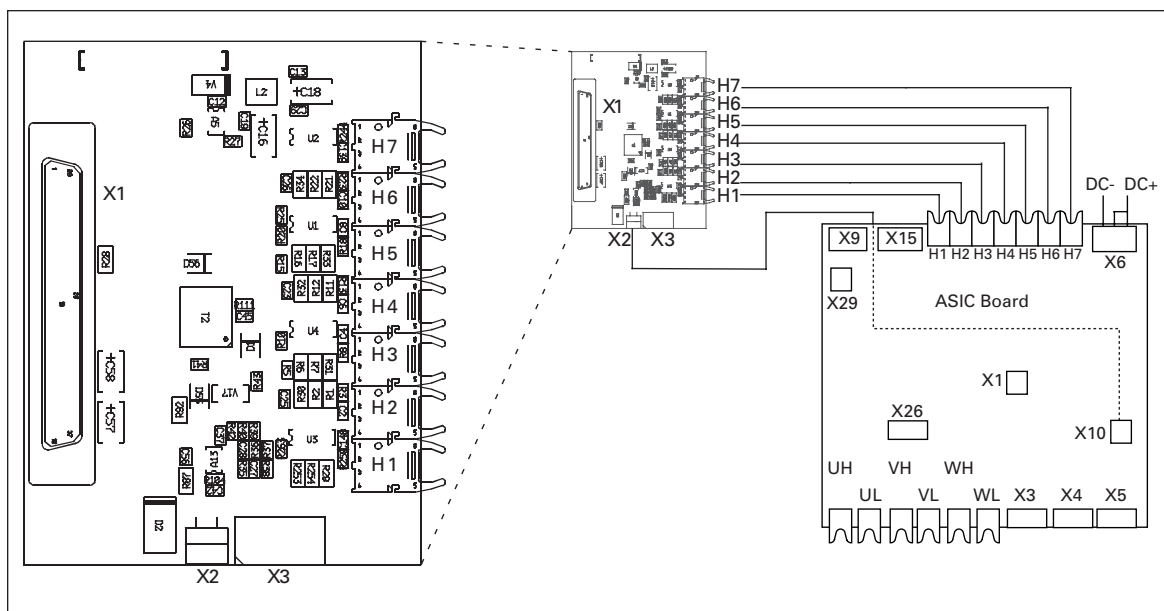
Remove the protective cover to reveal the D-connector on the power unit. Connect one end of the communication cable to the D-connector of the power unit and the other end to the control unit. If the Optical Cable Adapter Board (see below) sits on the D-connector of the control unit, you have to remove it first. See **Figure 4-18** below.

#### **Connections with Optical Cable**

If optical cables are used to link the power unit and the control board, a special Optical Cable Adapter Board connected to the control board D-connector must be used. To connect the optical cables to the power unit, you will have to remove the protective cover first. See **Figure 4-18**. Connect the optical cables as shown in **Figure 4-19**. Also see **Page 4-10**, Control Unit Mounting Box. The maximum length of the optical cable is 33 feet (10m).



**Figure 4-18: Remove Cover to Access Power Unit**



**Figure 4-19: Optical Cable Adapter Board**

**Table 4-6: Terminals on Adapter Board**

Terminal	Description	Terminal	Description
<b>Optical Terminals on Optical Cable Adapter Board</b>		<b>Other Terminals on Adapter Board</b>	
H1	Gate control enable	X1	Control board connection
H2	Phase U control	X2	Supply voltage 24V <sub>in</sub> (from power unit ASIC)
H3	Phase V control	X3	Supply voltage 24V <sub>in</sub> (customer); • Max. current 1A • Terminal #1: + • Terminal #2: -
H4	Phase W control		
H5	ADC synchronization		
H6	Bus data from control board to ASIC		
H7	Bus data from ASIC to control board		

**Note:** The minimum optical cable bending radius is 1.97 inches (50 mm).

**Note:** Terminals X2 and X3 can be in use simultaneously. However, if the +24V supply from the control I/O terminals (e.g. from board OPT-A1) is used, this terminal must be protected with a diode.



September 2007

## Chapter 5 — Menu Information

### Keypad Operation

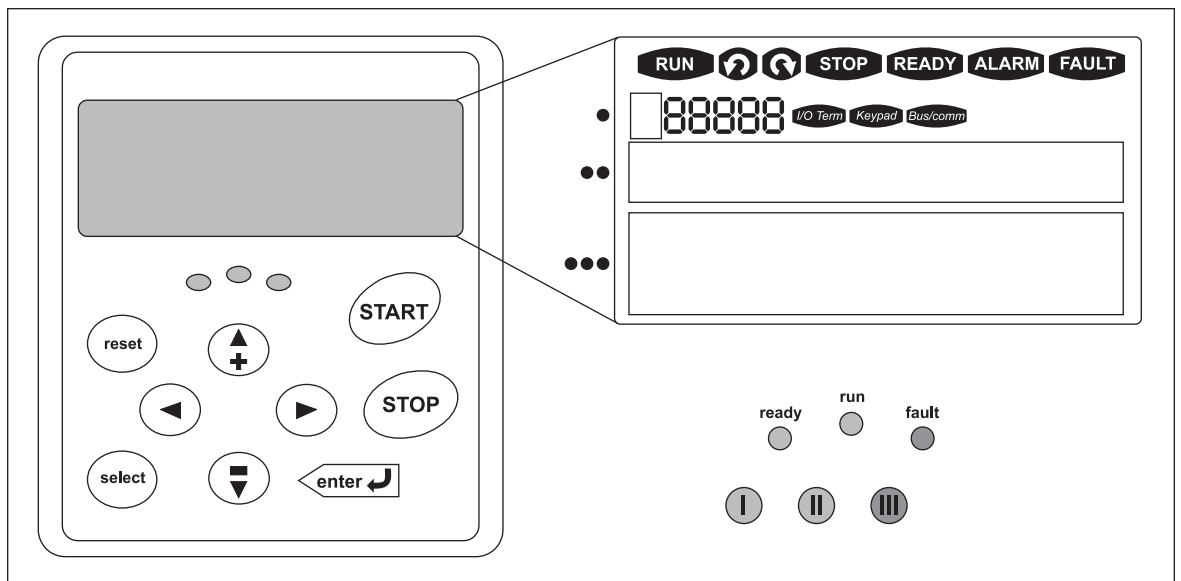
The control keypad is the link between the LCX9000 drive and the user. The control keypad features an alphanumeric display with seven indicators for the Run status (RUN, counter-clockwise, clockwise, READY, STOP, ALARM, FAULT) and three indicators for the control place (I/O term/Keypad/BusComm). There are also three Status Indicator LEDs (green – green – red), see **Page 5-3**.

The control information, i.e. the menu number, description of the menu or the displayed value and the numeric information are presented on three text lines.

The drive is operable through the nine pushbuttons of the control keypad. Furthermore, the buttons can be used in setting parameters and monitoring values.

The keypad is detachable and isolated from the input line potential.

### Indicators on the Keypad Display









**Figure 5-1: Control Keypad and Drive Status Indications**

### Drive Status Indicators

The drive status symbols tell the user the status of the motor and the drive. In addition, they tell about possible irregularities detected by the motor control software in motor or drive functions.




**Table 5-1: Drive Status Indicators**

Indicator	Description
	<b>RUN</b> Motor is running; Blinks when the stop command has been given but the frequency is still ramping down.
	Indicates the direction of motor rotation.
	<b>STOP</b> Indicates that the drive is not running.
	<b>READY</b> Lights up when AC power is on. In case of a trip, the symbol will not light up.
	<b>ALARM</b> Indicates that the drive is running outside a certain limit and a warning is given.
	<b>FAULT</b> Indicates that unsafe operating conditions were encountered due to which the drive was stopped.

### Control Place Indicators

The symbols I/O term, Keypad and Bus/Comm (see **Table 5-2**) indicate the choice of control place made in the Keypad control menu (M3) (see **Page 5-9**).

**Table 5-2: Control Place Indicators**




Indicator	Description
	<b>I/O Terminal</b> I/O terminals are selected as the control place i.e. START/STOP commands or reference values etc. are given through the I/O terminals.
	<b>Keypad</b> Control keypad is selected as the control place i.e. the motor can be started or stopped, or its reference values etc. altered from the keypad.
	<b>Bus/Comm</b> The drive is controlled through a fieldbus.

September 2007

**Status LEDs (Green – Green – Red)**

The status LEDs light up in connection with the READY, RUN and FAULT drive status indicators.




**Table 5-3: Status LEDs (Green – Green – Red)**

Indicator	Description
	Lights up with the AC power connected to the drive. Simultaneously, the drive status indicator READY is lit up.
	Lights up when the drive is running. Blinks when the STOP button has been pushed and the drive is ramping down.
	Lights up when unsafe operating conditions were encountered due to which the drive was stopped (Fault Trip). Simultaneously, the drive status indicator FAULT blinks on the display and the fault description can be seen, see <b>Page 5-11</b> , Active faults.

**Text Lines**

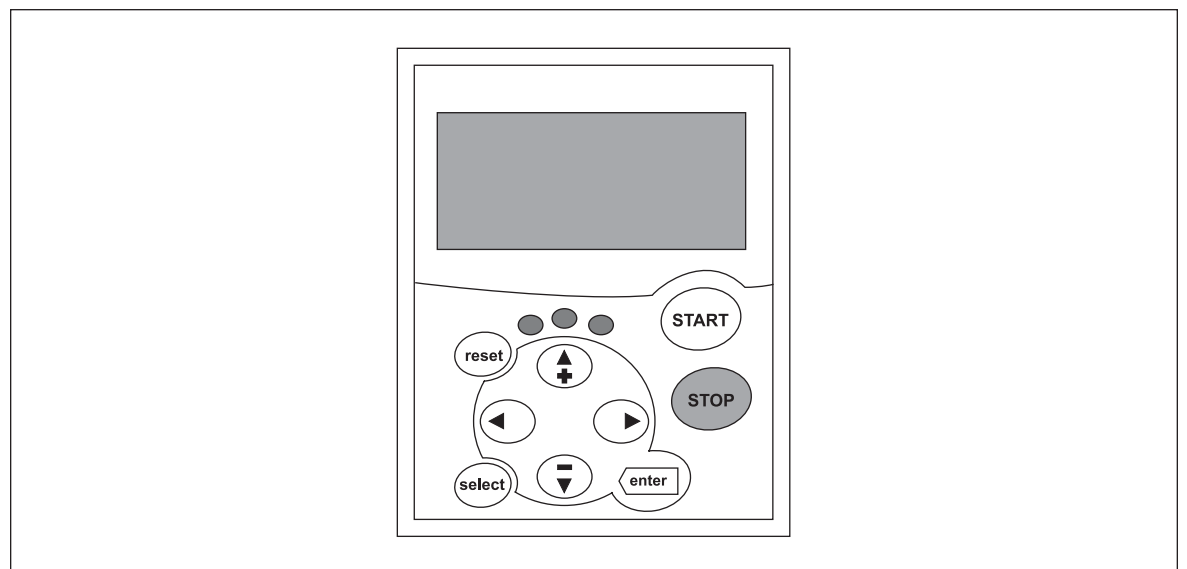
The three text lines provide the users with information on their present location in the keypad menu structure as well as with information related to the operation of the drive.

**Table 5-4: Text Lines**

Indicator	Description
	Location indicator: displays the symbol and number of the menu, parameter, etc. Example: M2 = Menu 2 (Parameters); P2.1.3 = Acceleration time.
	Description line: Displays the description of the menu, value or fault.
	Value line: Displays the numerical and textual values of references, parameters, etc. and the number of submenus available in each menu.










**Keypad Pushbuttons**

The alphanumeric control keypad has nine pushbuttons that are used for controlling the drive (and motor), setting parameters and monitoring values.



**Figure 5-2: Keypad Pushbuttons**

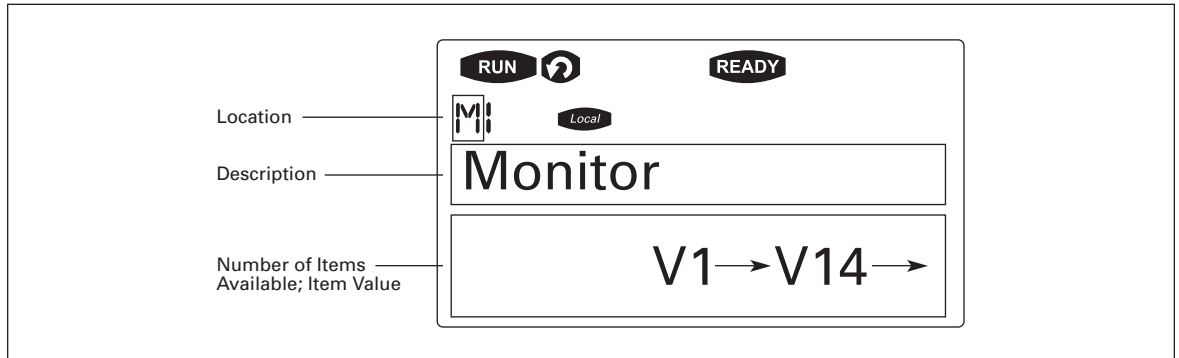
**Table 5-5: Button Descriptions**

Indicator	Description
	<b>RESET</b> This button is used to reset active faults (see <b>Page 5-11</b> ).
	<b>SELECT</b> This button is used to switch between the two latest displays. This may be useful when you want to see how the changed new value influences some other value.
	<b>ENTER</b> The ENTER button is used for: <ul style="list-style-type: none"> <li>• confirmation of selections</li> <li>• fault history reset (2 – 3 seconds)</li> </ul>
	<b>Browser Button Up</b> Browse the main menu and the pages of different submenus. Edit values.
	<b>Browser Button Down</b> Browse the main menu and the pages of different submenus. Edit values.
	<b>Menu Button Left</b> Move backward in menu. Move cursor left (in parameter menu). Exit edit mode. Press for 2 to 3 seconds to return to main menu.
	<b>Menu Button Right</b> Move forward in menu. Move cursor right (in parameter menu). Enter edit mode.
	<b>START Button</b> Pressing this button starts the motor if the keypad is the active control place. See <b>Page 5-10</b> .
	<b>STOP Button</b> Pressing this button stops the motor (unless disabled by parameter R3.4/ R3.6). See <b>Page 5-10</b> .

September 2007

## Menu Navigation

The data on the control keypad is arranged in menus and submenus. The menus are used for the display and editing of measurement and control signals, parameter settings and reference value and fault displays. Through the menus, you can also adjust the contrast of the display.



**Figure 5-3: Keypad Display Data**

The first menu level consists of menus M1 to M7 and is called the Main menu. The user can navigate in the main menu with the Browser buttons up and down. The desired submenu can be entered from the main menu with the menu buttons. When there still are pages to enter under the currently displayed menu or page, you can see an arrow in the lower right corner of the display and can reach the next menu level by pressing Menu Button Right.

The control keypad navigation chart is shown in **Figure 5-4**. Please note that menu M1 is located in the lower left corner. From there you will be able to navigate your way up to the desired menu using the menu and browser buttons.

You will find more detailed descriptions of the menus later in this chapter.

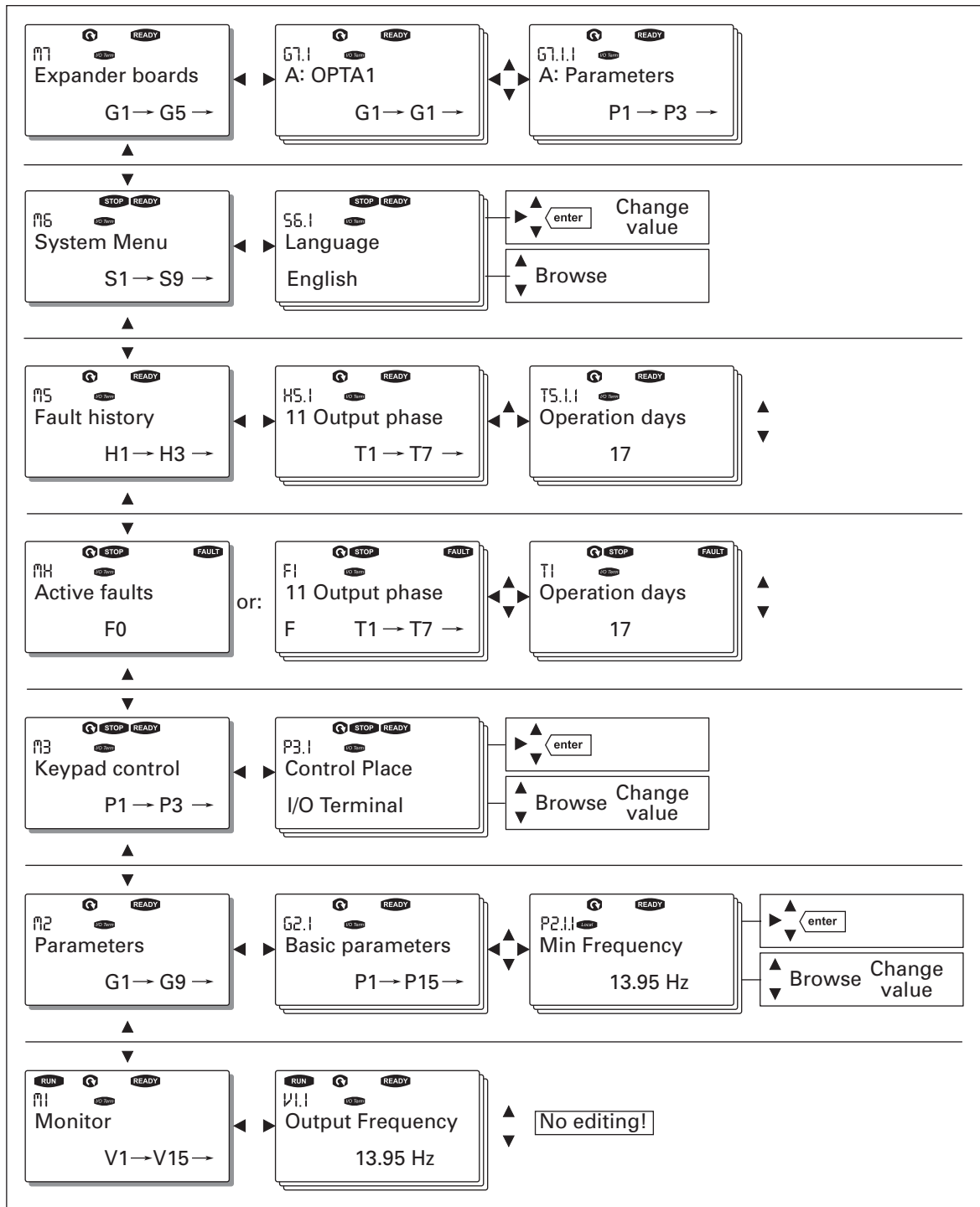


Figure 5-4: Keypad Navigation Chart

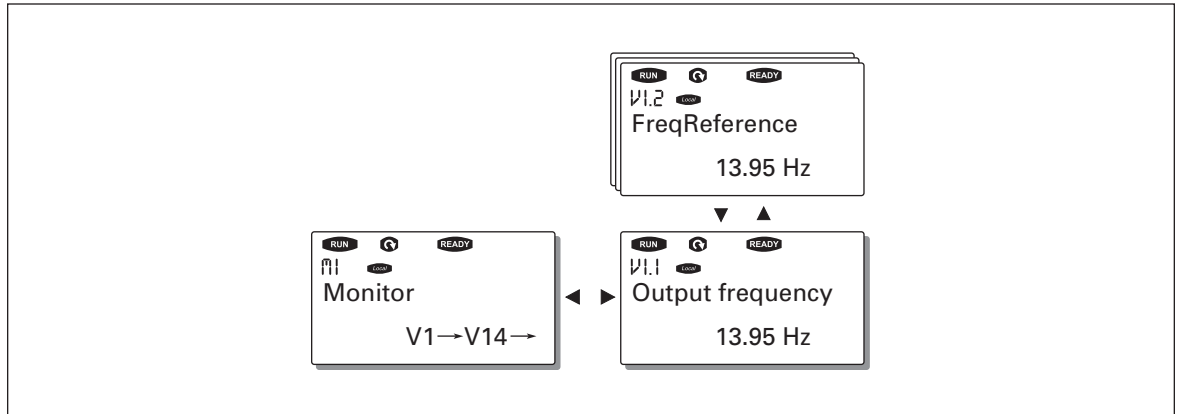
September 2007

**Monitoring Menu (M1)**

You can enter the Monitoring menu from the Main menu by pressing Menu Button Right when the location indication M1 is visible on the first line of the display. **Figure 5-5** shows how to browse through the monitored values.

The monitored signals carry the indication V#.# and they are listed in **Table 5-6**. The values are updated once every .3 seconds.

This menu is meant only for signal checking. The values cannot be altered here. For changing values of parameters, see **Page 5-8**.



**Figure 5-5: Monitoring Menu**

**Table 5-6: Monitored Signals**

Code	Signal Name	Unit	Description
V7.1	Output frequency	Hz	Frequency to the motor
V7.2	Frequency reference	Hz	
V7.3	Motor speed	rpm	Calculated motor speed
V7.4	Motor current	A	Measured motor current
V7.5	Motor torque	%	Calculated torque based/nominal torque of the unit
V7.6	Motor power	%	Calculated actual power/nominal power of the unit
V7.7	Motor voltage	V	Calculated motor voltage
V7.8	DC-link voltage	V	Measured DC-link voltage
V7.9	Unit temperature	°C	Heatsink temperature
V7.10	Motor temperature	%	Calculated motor temperature
V7.11	Voltage input	V	AI1
V7.12	Current input	mA	AI2
V7.13	DIN1, DIN2, DIN3	—	Digital input statuses
V7.14	DIN4, DIN5, DIN6	—	Digital input statuses
V7.15	DO1, RO2, RO3	—	Digital and relay output statuses
V7.16	Analog output current	mA	AO1
M1.17	Multimonitoring items		Displays three selectable monitoring values. See <b>Page 5-23</b> .

**Note:** Applications may embody more monitoring values.

### Parameter Menu (M2)

Parameters are the way of conveying the commands of the user to the drive. Parameter values can be edited by entering the Parameter Menu from the Main Menu when the location indication M2 is visible on the first line of the display. The value editing procedure is presented in **Figure 5-6**.

Pressing Menu Button Right once takes you to the Parameter Group Menu (G#). Locate the desired parameter group by using the Browser buttons and press Menu Button Right again to see the group and its parameters. Use the Browser buttons to find the parameter (P#) you want to edit. Pressing Menu Button right takes you to the edit mode. As a sign of this, the parameter value starts to flash. You can now change the value in two different ways:

- Set the desired value with the Browser buttons and confirm the change with the ENTER button. Consequently, the blinking stops and the new value is visible in the value field.
- Press Menu Button Right once more. Now you will be able to edit the value digit by digit. This may come in handy, when a relatively greater or smaller value than that on the display is desired. Confirm the change with the ENTER button.

The value will not change unless the ENTER button is pressed. Pressing Menu Button Left takes you back to the previous menu.

Several parameters are locked, i.e. cannot be edited, when the drive is in RUN status. If you try to change the value of such a parameter the text \*Locked\* will appear on the display. The drive must be stopped to edit these parameters.

The parameter values can also be locked using the function in menu M6 (see **Page 5-22**).



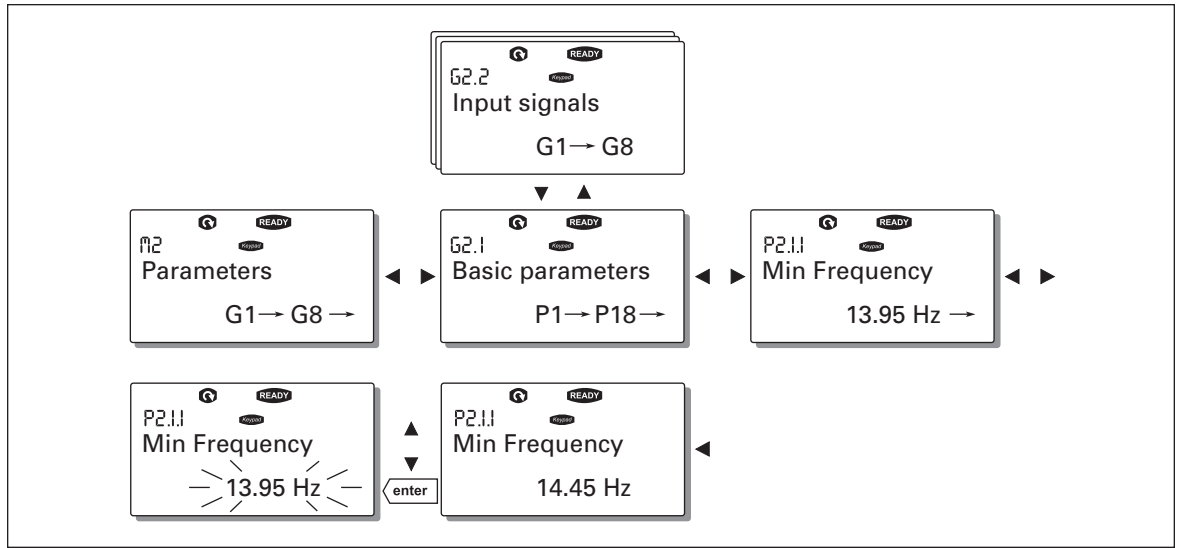
September 2007

You can return to the Main menu any time by pressing Menu Button Left for 1 to 2 seconds.

The basic application package includes seven applications with different sets of parameters. You will find the parameter lists in the application manual.

Once in the last parameter of a parameter group, you can move directly to the first parameter of that group by pressing Browser button up.

See the diagram for parameter value change procedure in **Figure 5-6**.



**Figure 5-6: Parameter Value Change Procedure**

**Keypad Control Menu (M3)**

In the Keypad Control Menu, you can choose the control place, edit the frequency reference and change the direction of the motor. You can enter the submenu level by pressing Menu Button Right.

**Table 5-7: Keypad Control Parameters, M3**

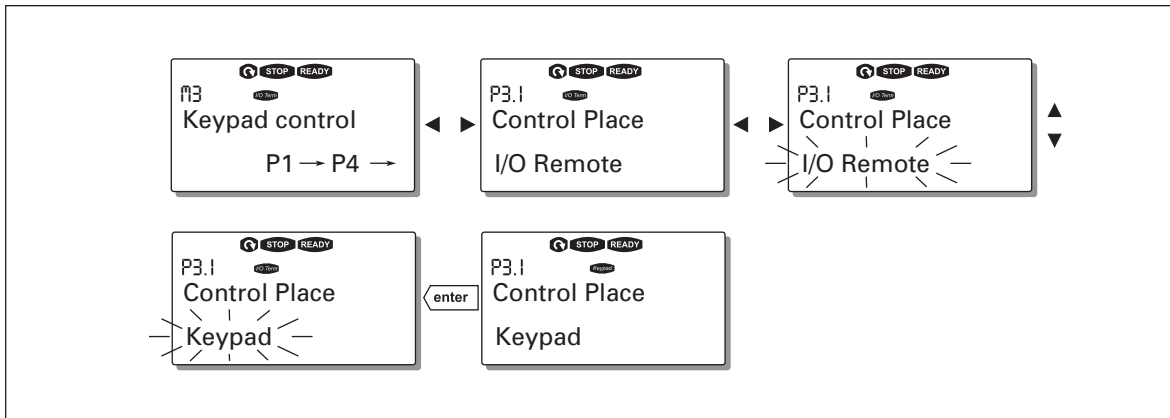
Code	Parameter	Min.	Max.	Unit	Default	Cust.	ID	Note
P3.1	Control place	1	3		1		125	1 = I/O terminal 2 = Keypad 3 = Fieldbus
P3.2	Keypad reference	Par. 2.1.1	Par. 2.1.2	Hz				
P3.3	Direction (on keypad)	0	1		0		123	0 = Forward 1 = Reverse
R3.4	Stop button	0	1		1		114	0 = Limited function of Stop button 1 = Stop button always enabled

### Selection of Control Place

There are three different places (sources) where the drive can be controlled. For each control place, a different symbol will appear on the alphanumeric display:

- I/O terminals
- Keypad (panel)
- Fieldbus

You can change the control place by entering the edit mode with Menu Button Right. The options can then be browsed with the Browser buttons. Select the desired control place with the ENTER button. See **Figure 5-7**.



**Figure 5-7: Selection of Control Place**

### Keypad Reference

The keypad reference submenu (P3.2) displays and allows the operator to edit the frequency reference. The changes will take place immediately. This reference value will not, however, influence the rotation speed of the motor unless the keypad has been selected as the source of reference.

**Note:** The maximum difference in RUN mode between the output frequency and the keypad reference is 6 Hz. The program automatically monitors the keypad reference value.

You may edit the reference value (pressing the ENTER button is not necessary).

### Keypad Direction

The keypad direction submenu displays and allows the operator to change the rotating direction of the motor. This setting will not, however, influence the rotation direction of the motor unless the keypad has been selected as the active control place.

**Note:** For additional information on controlling the motor with the keypad, see **Pages 5-3 and 6-2**.

September 2007

### STOP Button Activated

By default, pushing the STOP button will always stop the motor regardless of the selected control place. You can disable this function by giving parameter 3.4 the value 0. If the value of this parameter is 0, the STOP button will stop the motor only when the keypad has been selected as the active control place.

**Note:** There are some special functions that can be performed in menu M3:

Select the keypad as the active control place by pressing start for 3 seconds when the motor is running. The keypad will become the active control place and the current frequency reference and direction will be copied to the keypad.

Select the keypad as the active control place by pressing stop for 3 seconds when the motor is stopped. The keypad will become the active control place and the current frequency reference and direction will be copied to the keypad.

Copy the frequency reference set elsewhere (I/O, fieldbus) to the panel by pressing enter for 3 seconds.

**Note:** If you are in any other menu than menu M3, these functions will not work.

If you are in some other menu than menu M3 and try to start the motor by pressing the START button when the keypad is not selected as the active control place, you will get an error message: Keypad Control NOT ACTIVE.

### Active Faults Menu (M4)

You can enter the Active Faults menu from the Main menu by pressing Menu Button Right when the location indication M4 is visible on the first line of the keypad display.

When a fault brings the drive to a stop, the location indication F1, the fault code, a short description of the fault, and the fault type symbol (see below) will appear on the display. In addition, the indication FAULT or ALARM (see **Table 5-1**) is displayed and, in case of a FAULT, the red LED on the keypad starts to flash. If several faults occur simultaneously, the list of active faults can be browsed with the Browser buttons.

The memory of active faults can store a maximum of 10 faults in the order of appearance. The display can be cleared with the RESET button and the read-out will return to the same state it was in before the fault trip. The fault remains active until it is cleared with the RESET button or with a reset signal from the I/O terminal.

**Note:** Remove external Start signal before resetting the fault to prevent unintentional restart of the drive.

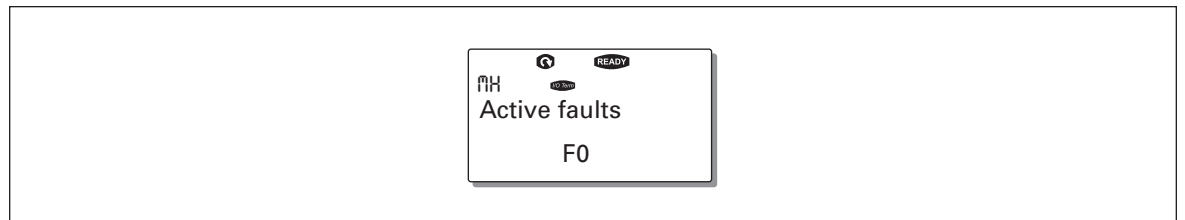
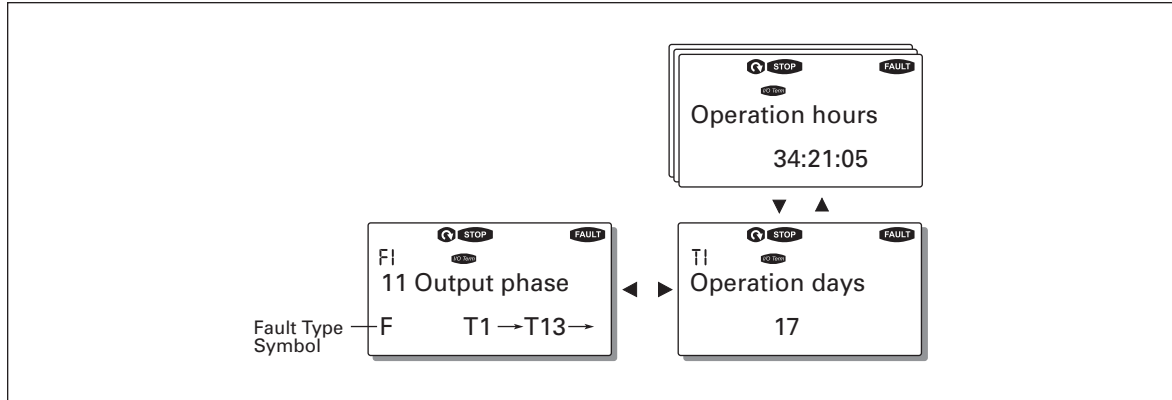


Figure 5-8: Normal State, No Faults

## Fault Types

The drive has four types of faults. These types differ from each other on the basis of the subsequent behavior of the drive. See **Table 5-8**.



**Figure 5-9: Fault Display**

**Table 5-8: Fault Types**

Fault Type Symbol	Meaning
A (Alarm)	This type of fault is a sign of an unusual operating condition. It does not cause the drive to stop, nor does it require any special actions. The "A fault" remains in the display for about 30 seconds.
F (Fault)	An "F fault" makes the drive stop. Actions need to be taken to restart the drive.
AR (Fault Autoreset)	If an "AR fault" occurs the drive will stop immediately. The fault is reset automatically and the drive tries to restart the motor. Finally, if the restart is not successful, a fault trip (FT, see below) occurs.
FT (Fault Trip)	If the drive is unable to restart the motor after an AR fault an FT fault occurs. The "FT fault" has basically the same effect as the F fault: the drive is stopped.

**Note:** Fault Codes are listed in **Appendix A**.

### Fault Time Data Record

When a fault occurs, the information described in **Figure 5-8** is displayed. By pressing Menu Button Right, you will enter the Fault time data record menu indicated by T.1→T.#. In this menu, some selected important data valid at the time of the fault are recorded. This feature will help the user or the service person in determining the cause of the fault.

September 2007

The data available are:

**Table 5-9: Fault Time Recorded Data**

Data	Units	Description
T.1	D	Counted operation days (Fault 43: Additional code)
T.2	hh:mm:ss (d)	Counted operation hours (Fault 43: Counted operation days)
T.3	Hz hh:mm:ss	Output frequency (Fault 43: Counted operation hours)
T.4	A	Motor current
T.5	V	Motor voltage
T.6	%	Motor power
T.7	%	Motor torque
T.8	V	DC bus voltage
T.9	°C	Unit temperature
T.10	—	Run status
T.11	—	Direction
T.12	—	Warnings
T.13	—	Zero speed <sup>①</sup>

<sup>①</sup> Tells the user if the drive was at zero speed (<0.01 Hz) when the fault occurred

**Real Time Record**

If real time is set to run on the drive, the data items T1 and T2 will appear as follows:

**Table 5-10: Real Time Record**

Data	Units	Description
T.1	yyyy-mm-dd	Counted operation days
T.2	hh:mm:ss,sss	Counted operation hours

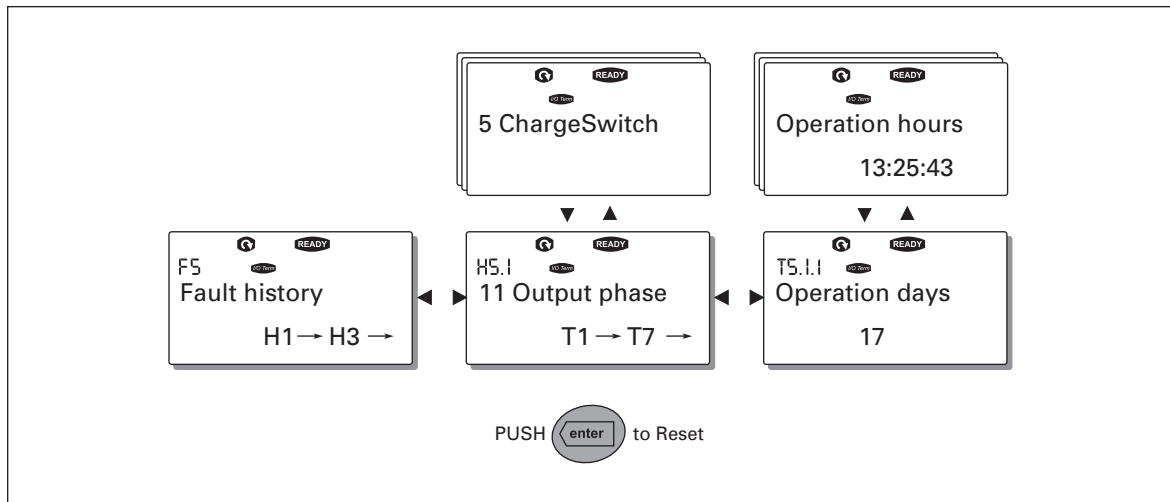
**Fault History Menu (M5)**

You can enter the Fault History menu from the Main menu by pressing Menu Button Right when the location indication M5 is visible on the first line of the keypad display.

All faults are stored in the Fault History menu where you can browse them with the Browser buttons. Additionally, the Fault Time Data Record pages (see **Page 5-12**) are accessible for each fault. You can return to the previous menu any time by pressing Menu Button Left.

The memory of the drive can store a maximum of 30 faults in order of appearance. The number of faults currently in the fault history is shown on the value line of the main page (H1→H#). The order of the faults is indicated by the location indication in the upper left corner of the display. The latest fault is indicated by F5.1, the one before that by F5.2 and so on. If there are 30 uncleared faults in the memory, the next fault will erase the oldest fault from the memory.

Pressing the ENTER button for about 2 to 3 seconds resets the whole fault history. The symbol H# will change to 0.



**Figure 5-10: Fault History Menu**

### **System Menu (M6)**

You can enter the System menu from the Main menu by pressing Menu Button Right when the location indication M6 is visible on the first line of the keypad display.

The controls associated with the general use of the drive, such as application selection, customized parameter sets or information about the hardware and software are located under the System menu. The number of submenus and subpages is shown with the symbol S (or P) on the value line.

**Table 5-11** has a list of the functions available in the System menu.

September 2007

**Table 5-11: System Menu Functions**

Code	Function	Min	Max	Unit	Default	Cust	Selections
S6.1	Selection of language				English		English Deutsch Suomi Svenska Italiano
S6.2	Application selection				Basic Application		Basic Application Standard Application Local/Remote control Appl. Multi-Step Application PID Control Application Multi-Purpose Control Appl. Pump and Fan Control Appl.
S6.3	Copy parameters						
S6.3.1	Parameter sets						Store set 1 Load set 1 Store set 2 Load set 2 Load factory defaults
S6.3.2	Load to keypad						All parameters
S6.3.3	Load from keypad						All parameters All but motor parameters Application parameters
P6.3.4	Parameter backup				Yes		Yes No
S6.4	Parameter comparison						
S6.4.1	Set1				Not used		
S6.4.2	Set2				Not used		
S6.4.3	Factory settings						
S6.4.4	Keypad set						
S6.5	Security						
S6.5.1	Password				Not used		0=Not used
P6.5.2	Parameter locking				Change Enabled		Change Enabled Change Disabled
S6.5.3	Start-Up Wizard						No Yes
S6.5.4	Multimonitoring items				Change Enabled		Change Enabled Change Disabled
S6.6	Keypad settings						
P6.6.1	Default page						
P6.6.2	Default page/ Operating Menu						
P6.6.3	Timeout time	0	65535	s	30		
P6.6.4	Contrast	0	31		18		
P6.6.5	Backlight time	Always	65535	min	10		
S6.7	Hardware settings						

**Table 5-11: System Menu Functions (Continued)**

Code	Function	Min	Max	Unit	Default	Cust	Selections
P6.7.3	HMI acknowledg.	200	5000	ms	200		
P6.7.4	HMI: no. of retries	1	10		5		
S6.8	System information						
S6.8.1	Total counters						
C6.8.10.1	MWh counter			kWh			
C6.8.10.2	Power On day counter						
C6.8.1.3	Power On hour counter			hh:mm:ss			
S6.8.2	Trip counters						
T6.8.2.1	MWh counter			kWh			
T6.8.2.2	Clear MWh counter						
T6.8.2.3	Operating days counter						
T6.8.2.4	Operating hours counter			hh:mm:ss			
T6.8.2.5	Clear operating hour counter						
S6.8.3	Software information						
S6.8.3.1	Software package						
S6.8.3.2	System software version						
S6.8.3.3	Firmware interface						
S6.8.3.4	System load						
S6.8.4	Applications						
S6.8.4.#	Name of application						
D6.8.4.#.1	Application ID						
D6.8.4.#.2	Applications: version						
D6.8.4.#.3	Applications: firmware interface						
S6.8.5	Hardware						
I6.8.5.1	Unit power						
I6.8.5.2	Unit voltage						
I6.8.5.3	Info: Brake chopper						
I6.8.5.4	Info: Brake resistor						
S6.8.6	Expander boards						
S6.8.7	Debug menu						For application programming only. Contact Eaton.



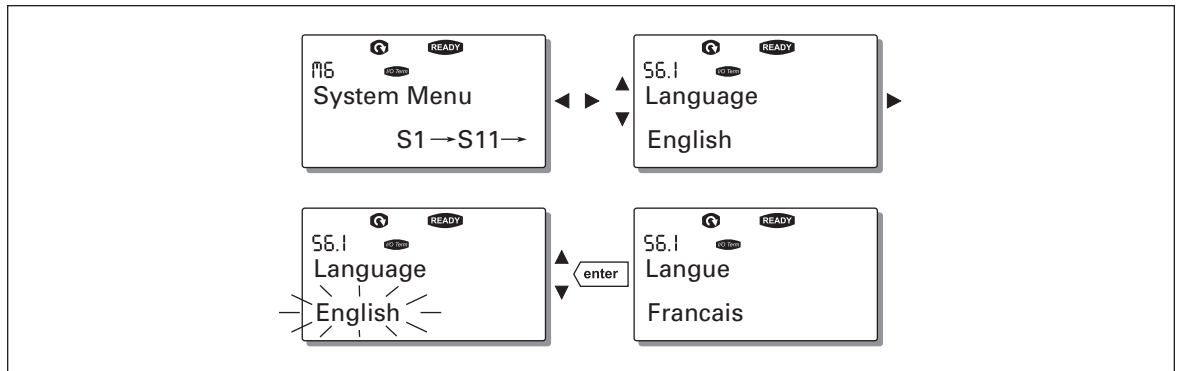
September 2007

**Selection of Language**

The control keypad allows you to control the drive through the keypad in the language of your choice.

Locate the language selection page under the System menu. Its location indication is S6.1. Press Menu Button Right once to enter the edit mode. As the name of the language starts to flash, you can select another language for the keypad texts. Confirm with the ENTER button. The flashing stops and all text information on the keypad is presented in the selected language.

You can return to the previous menu any time by pressing Menu Button Left.



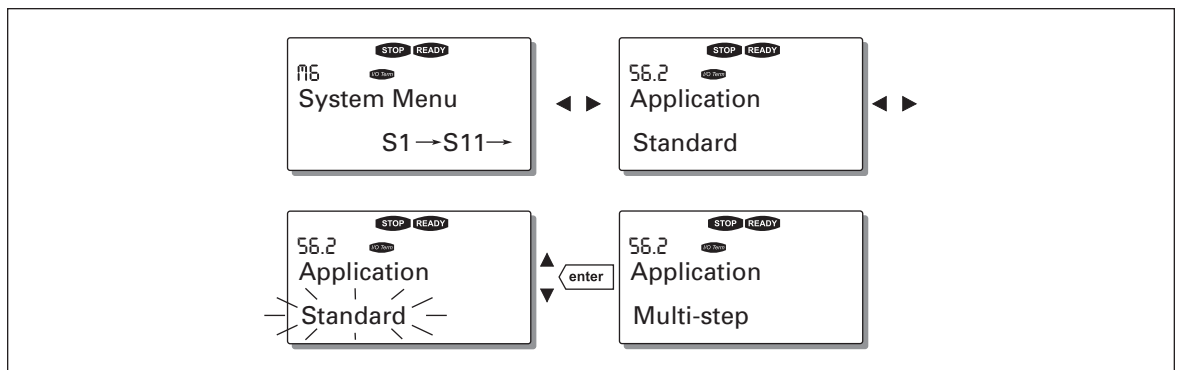
**Figure 5-11: Selection of Language**

**Application Selection**

The user can select the desired application on the Application selection page (S6.2). To enter the page, press Menu Button Right on the first page of the System menu. To change the application, press Menu Button Right once more. The name of the application starts to flash. Now you can browse the applications with the Browser buttons and select the desired application with the ENTER button.

Changing the application will reset all parameters. After application change, you will be asked if you want the parameters of the new application to be uploaded to the keypad. If you want to do this, press the ENTER button. Pressing any other button leaves the parameters of the previously used application saved in the keypad.

For more information about the application, see the application manual.



**Figure 5-12: Change of Application**

## Copy Parameters

The parameter copy function is used when the operator wants to copy one or all parameter groups from one drive to another or to store parameter sets in the internal memory of the drive. All the parameter groups are first uploaded to the keypad, then the keypad is connected to another drive and then the parameter groups are downloaded to it (or possibly back to the same drive).

Before any parameters can be successfully copied from one drive to another, the drive has to be stopped when the parameters are downloaded to it.

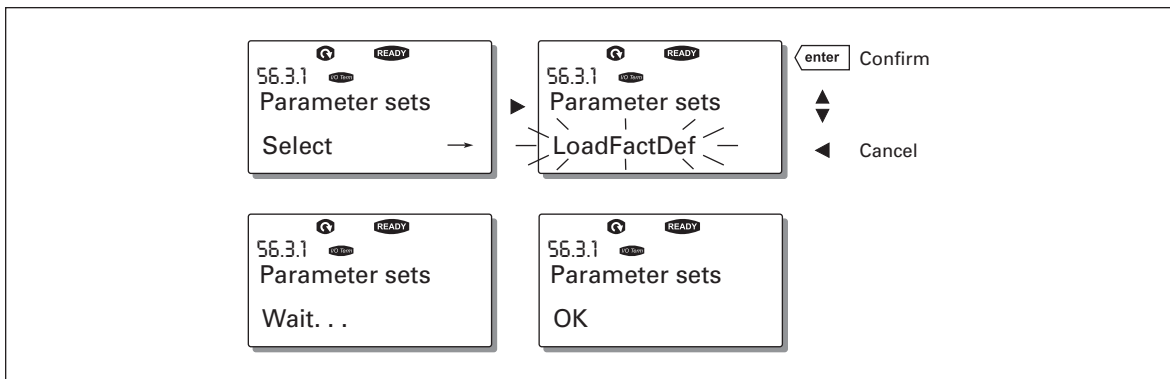
The parameter copy menu (S6.3) contains four functions:

### Parameter Sets (S6.3.1)

The user can reload the factory default parameter values and store and load two customized parameter sets (all parameters included in the application).

On the Parameter Sets page (S6.3.1), press Menu Button Right to enter the edit mode. The text LoadFactDef begins to flash and you can confirm the loading of factory defaults by pressing the ENTER button. The drive resets automatically.

Alternatively, you can choose any other storing or loading functions with the Browser buttons. Confirm with the ENTER button. Wait until "OK" appears on the display.



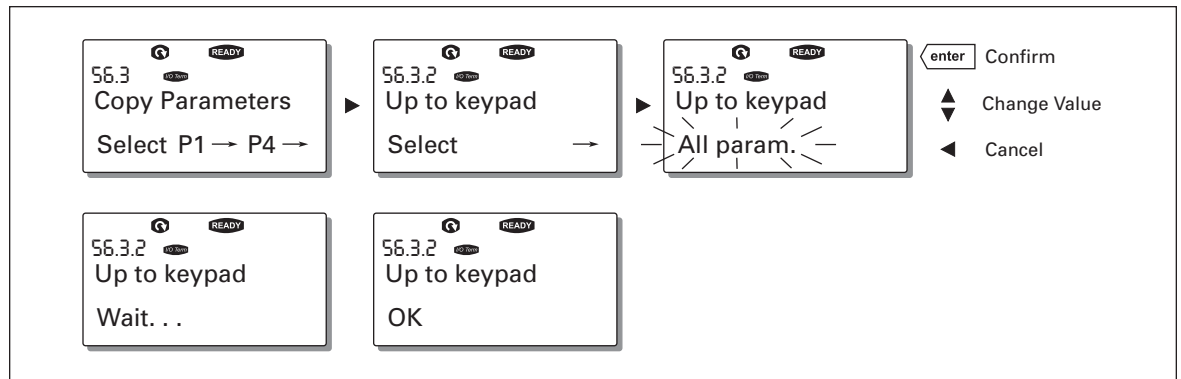
**Figure 5-13: Storing and Loading of Parameter Sets**

### Upload parameters to keypad (To keypad, S6.3.2)

This function uploads all existing parameter groups to the keypad provided that the drive is stopped.

Enter the To Keypad page (S6.3.2) from the Parameter Copy menu. Pressing Menu Button Right takes you to the edit mode. Use the Browser buttons to select the option All Parameters and press the ENTER button. Wait until "OK" appears on the display.

September 2007



**Figure 5-14: Parameter Copy to Keypad**

*Download parameters to drive (From keypad, S6.3.3)*

This function downloads one or all parameter groups uploaded to the keypad to a drive provided that the drive is in STOP status.

Enter the From Keypad page (S6.3.2) from the Parameter Copy menu. Pressing the Menu Button Right takes you to the edit mode. Use the Browser buttons to select either All Parameters or Application Parameters and press the ENTER button. Wait until "OK" appears on the display.

The procedure to download the parameters from keypad to drive is similar to that of from drive to keypad. See **Figure 5-14**.

*Automatic Parameter Backup (P6.3.4)*

On this page you can activate or inactivate the parameter backup function. Enter the edit mode by pressing Menu Button Right. Select Yes or No with the Browser buttons.

When the Parameter backup function is activated, the control keypad makes a copy of the parameters of the presently used application. Every time a parameter is changed, the keypad backup is automatically updated.

When applications are changed, you will be asked if you wish the parameters of the new application to be uploaded to the keypad. If you want to do this, press the ENTER button. If you wish to keep the copy of the parameters of the previously used application saved in the keypad, press any other button. Now you will be able to download these parameters to the drive following the instructions given in Copy Parameters on **Page 5-18**.

If you want the parameters of the new application to be automatically uploaded to the keypad, you have to do this for the parameters of the new application once on page 6.3.2 as instructed. Otherwise the panel will always ask for permission to upload the parameters.

**Note:** Parameters saved in the parameter settings on page S6.3.1 will be deleted when applications are changed. If you want to transfer the parameters from one application to another, you have to upload them first to the keypad.

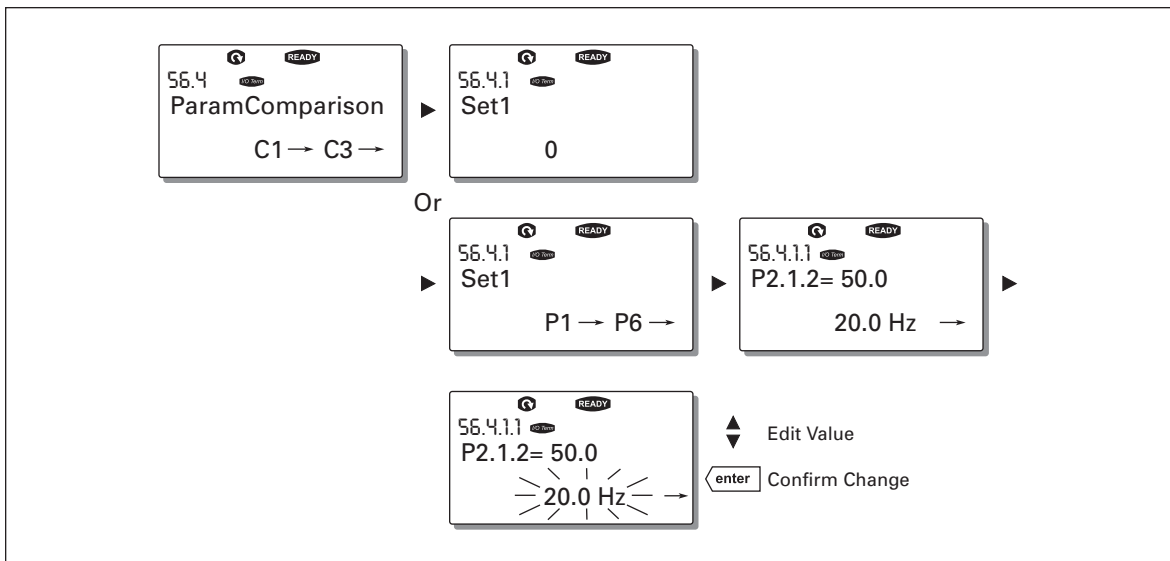
**Parameter Comparison**

In the Parameter Comparison submenu (S6.4), you can compare the actual parameter values to the values of your customized parameter sets and those loaded to the control keypad.

You can compare the parameter by pressing Menu Button Right in the Compare Parameters submenu. The actual parameter values are first compared to those of the customized parameter Set1. If no differences are detected, "0" is displayed on the lowermost line. If any of the parameter values differ from those of Set1, the number of the deviations is displayed together with symbol P (for example, P1→P5 = five deviating values). By pressing Menu Button Right once more, you can enter pages where you can see both the actual value and the value it was compared to. In this display, the value on the description line (in the middle) is the default value and the one on the value line (lowermost) is the edited value.

Furthermore, you can also edit the actual value with the Browser buttons in the edit mode which you can enter by pressing Menu Button Right once.

In the same way, you can perform the comparison of the actual values to Set2, Factory Settings and Keypad Set.



**Figure 5-15: Parameter Comparison**

September 2007

## Security

**Note:** The Security submenu is protected with a password. Store the password in a safe place!

### *Password (S6.5.1)*

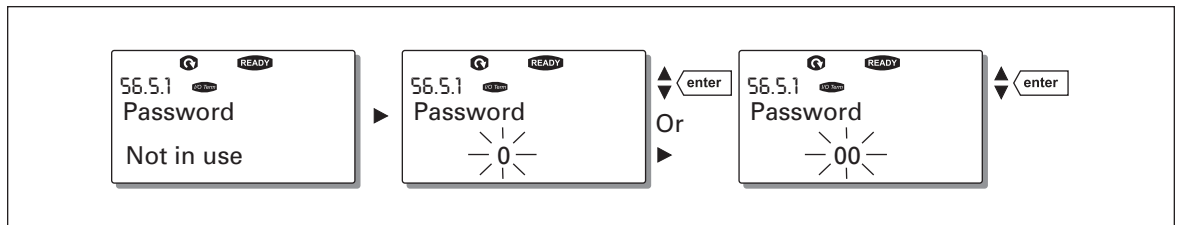
The application selection can be protected against unauthorized changes with the Password function (S6.5.1).

By default, the Password function is not in use. If you want to activate the function, enter the edit mode by pressing Menu Button Right. A flashing zero appears in the display and you can set a password with the Browser buttons. The password can be any number between 1 and 65535.

**Note:** You can also set the password by digits. In the edit mode, push Menu Button Right again and another zero appears on the display. Set ones first. To set the tens, press Menu Button Right, and so on. Confirm the password with the ENTER button. After this, you have to wait until the Timeout time (P6.6.3) (see **Page 5-24**) has expired before the password function is activated.

If you try to change applications or the password itself, you will be prompted for the current password. Enter the password with the Browser buttons.

You can deactivate the password function by entering the value 0.



**Figure 5-16: Password Setting**

**Note:** Store the password in a safe place! No changes can be made unless a valid password is entered.

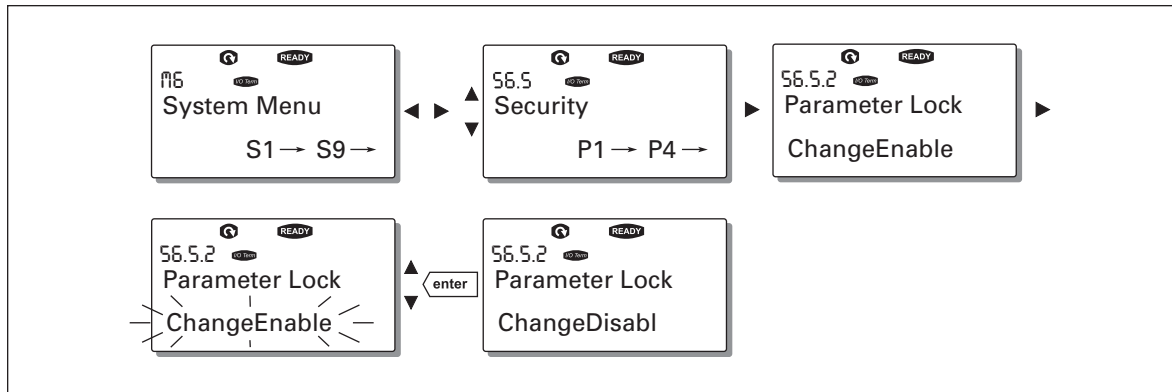
*Parameter Lock (P6.5.2)*

This function allows the user to prohibit changes to the parameters.

If the parameter lock is activated, the text *\*locked\** will appear on the display if you try to edit a parameter value.

**Note:** This function does not prevent unauthorized editing of parameter values.

Enter the edit mode by pressing Menu Button Right. Use the Browser buttons to change the parameter lock status. Confirm the change with the ENTER button or go back to the previous level by pressing Menu Button Left.



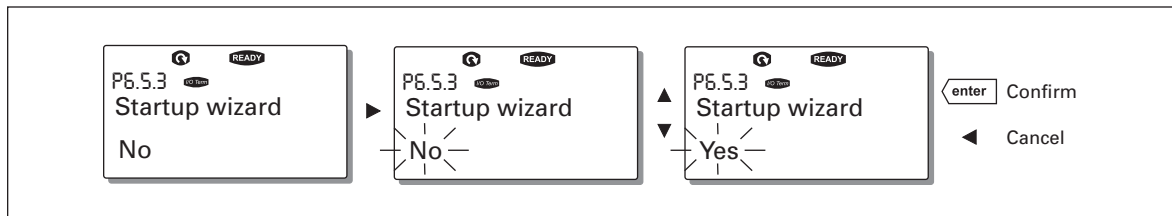
**Figure 5-17: Parameter Locking**

*Start-Up Wizard (P6.5.3)*

The Start-Up Wizard facilitates the commissioning of the drive. If active, the Start-Up Wizard prompts the operator for the language and application of his/her choice, plus for the values of parameters common to all applications, as well as for a set of application-specific parameters.

While in the Start-Up Wizard, the ENTER button accepts values and the Browser buttons scroll options or change values.

Activating the Start-Up Wizard: In the System Menu, find page P6.5.3. Press Menu Button Right once to enter the edit mode. Use the Browser buttons to select Yes and confirm the selection with the ENTER button. If you want to deactivate the function, follow the same procedure and give the parameter value "NO".

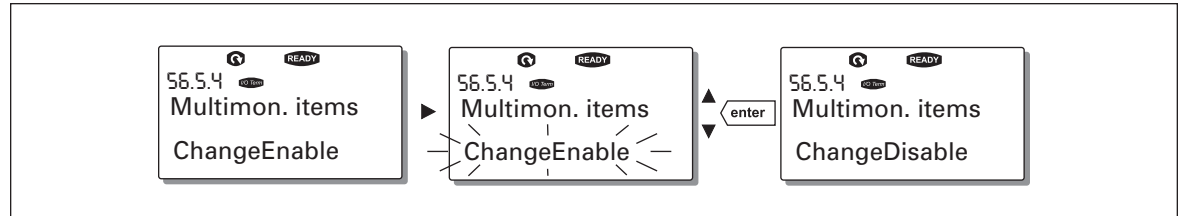


**Figure 5-18: Activation of Start-Up Wizard**

September 2007

*Multimonitoring Items (P6.5.4)*

The alphanumeric keypad features a display where you can monitor up to three actual values at the same time — see Monitoring Menu (M1) on **Page 5-7** and the manual of the application you are using. On page P6.5.4 of the System Menu, you can define whether the operator can replace the values monitored with other values. See below.

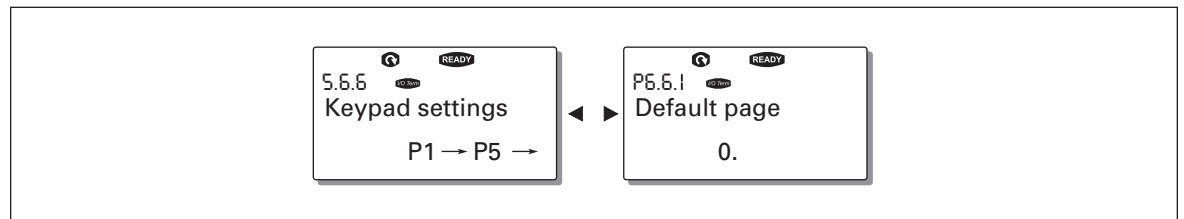


**Figure 5-19: Disabling the Change of Multimonitoring Items**

**Keypad Settings**

In the Keypad Settings submenu under the System menu, you can further customize your drive’s operator interface.

Locate the Keypad Setting submenu (S6.6). Under the submenu, there are four pages (P#) associated with the keypad operation:

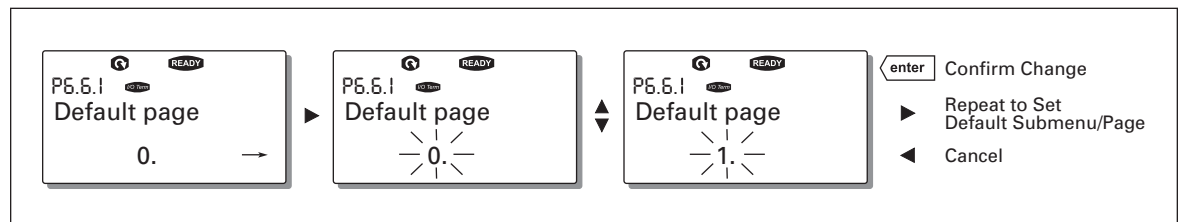


**Figure 5-20: Keypad Settings Submenu**

*Default Page (P6.6.1)*

Here you can set the location (page) to which the display automatically moves when the Timeout Time (see below) has expired or the power is switched on to the keypad.

If the default page is 0, the function is not activated, i.e. the latest displayed page remains on the keypad display. Pressing Menu Button Right takes you to the edit mode. Change the number of the Main menu with the Browser buttons. To edit the number of the submenu/page, press Menu Button Right. If the page you want to move to by default is at the third level, repeat the procedure. Confirm the new default page with the ENTER button. You can return to the previous menu at any time by pressing Menu Button Left.



**Figure 5-21: Default Page Function**

*Default page in the operating menu (P6.6.2)*

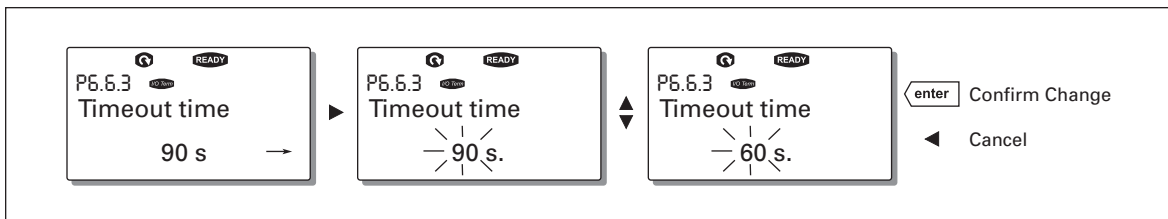
Here you can set the location (page) in the Operating menu (in special applications only) to which the display automatically moves to when the set Timeout Time (see below) has expired or the power is switched on to the keypad.

See how to set the Default page in **Figure 5-21**.

*Timeout Time (P6.6.3)*

The Timeout Time setting defines the time after which the keypad display returns to the Default page (P6.6.1).

Enter the edit mode by pressing Menu Button Right. Set the desired timeout time and confirm it with the ENTER button. You can return to the previous menu at any time by pressing Menu Button Left.



**Figure 5-22: Timeout Time Setting**

**Note:** If the Default page value is 0, the Timeout Time setting has no effect.

*Contrast Adjustment (P6.6.4)*

In case the display is unclear, you can adjust its contrast through the same procedure as for the timeout time setting (see above).

*Backlight Time (P6.6.5)*

By giving a value for the Backlight time, you can determine how long the backlight stays on before going out. You can select any time between 1 and 65535 minutes or "Forever." For the value setting procedure, see Timeout Time above.



September 2007

## Hardware Settings

**Note:** The Hardware settings submenu is protected with a password. Store the password in a safe place!

In the Hardware Settings submenu (S6.7) under the System menu, you can further control some functions of the hardware in your drive. The functions available in this menu are HMI acknowledge timeout and HMI retry.

### *HMI Acknowledge Timeout (P6.7.3)*

This function allows the user to change the timeout of the HMI acknowledgement time. The drive waits for the HMI acknowledgment in accordance with the value of this parameter.

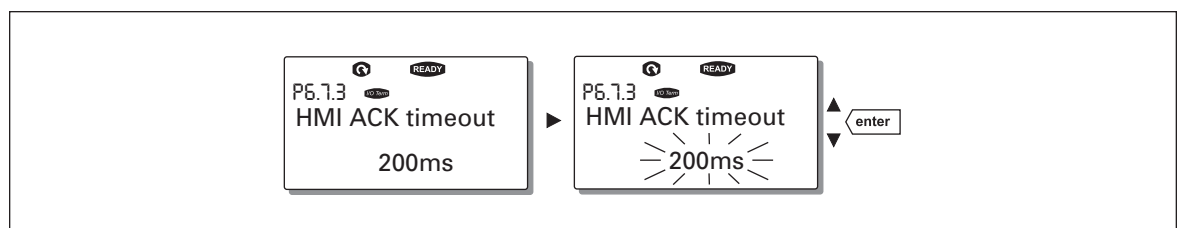
**Note:** If the drive has been connected to the PC with a normal cable, the default values of parameters 6.7.3 and 6.7.4 (200 and 5) must not be changed.

If the drive has been connected to the PC via a modem and there is a delay in transferring messages, the value of parameter 6.7.3 must be set according to the delay as follows:

Example:

- Transfer delay between the drive and the PC = 600 ms
- The value of par. 6.7.3 is set to 1200 mS (2 x 600, sending delay + receiving delay)
- The corresponding setting shall be entered in the [Misc] part of the file NCDrive.ini:
  - Retries = 5
  - AckTimeOut = 1200
  - TimeOut = 6000
- It must also be considered that intervals shorter than the AckTimeOut time cannot be used in NC-Drive monitoring.

Enter the edit mode by pressing Menu Button Right. The current value starts to flash. Use the Browser buttons to change the acknowledgement time. Confirm the change with the ENTER button or return to the previous level with Menu Button Left.



**Figure 5-23: HMI Acknowledge Timeout**

*Number of retries to receive HMI acknowledgement (P6.7.4)*

With this parameter you can set the number of times the drive will try to receive acknowledgement if it does not receive acknowledgement within the acknowledgement time (P6.7.3) or if the received acknowledgement is faulty.

You can change value through the same procedure as for P6.7.3 (see above).

**Note:** Changes to P6.7.3 and P6.7.4 become effective after the next start-up.

**System info**

In the System info submenu (S6.8) you can find drive-related hardware and software information.

*Total Counters*

The Total counters menu (S6.8.1) contains information on the drive operation times i.e. the total number of MWh, operating days and operating hours. Unlike the counters in the Trip counters menu, these counters cannot be reset.

**Note:** The Power On time counter (days and hours) always runs when the power is on.

**Table 5-12: Counter Pages**

Page	Counter	Example
C6.8.10.1	MWh counter	—
C6.8.10.2	Power On day counter	1.013 means the drive has operated for 1 year and 13 days
C6.8.1.3.	Power On hour counter	7:05:16 means the drive has operated for 7 hours, 5 minutes and 16 seconds

*Trip Counters*

Trip counters (menu S6.8.2) are counters the values of which can be reset, i.e. restored to zero. You can use the resettable counters in **Table 5-12**.

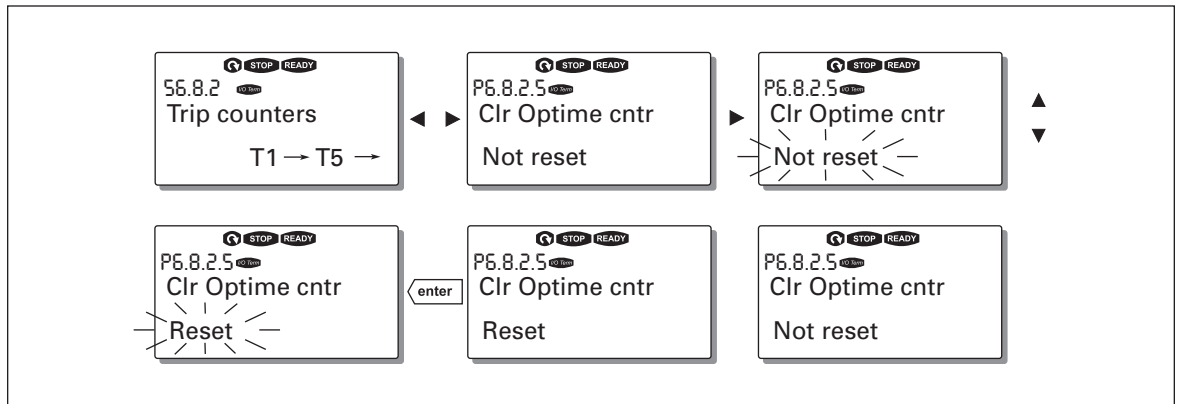
**Note:** The trip counters run only when the motor is running.

**Table 5-13: Resettable Counters**

Page	Counter
T6.8.2.1	MWh counter
T6.8.2.3	Operation day counter
T6.8.2.4	Operation hour counter

The counters can be reset on pages 6.8.2.2 (Clear MWh counter) and 6.8.2.5 (Clear Operating time counter).

**Example:** When you want to reset the operation counters, see **Figure 5-24**.



**Figure 5-24: Counter Reset**

*Software (S6.8.3)*

The Software information page includes information on the following drive software related topics:

**Table 5-14: Software Information Pages**

Page	Counter
6.8.3.1	Software packages
6.8.3.2	System software version
6.8.3.3	Firmware interface
6.8.3.4	System load

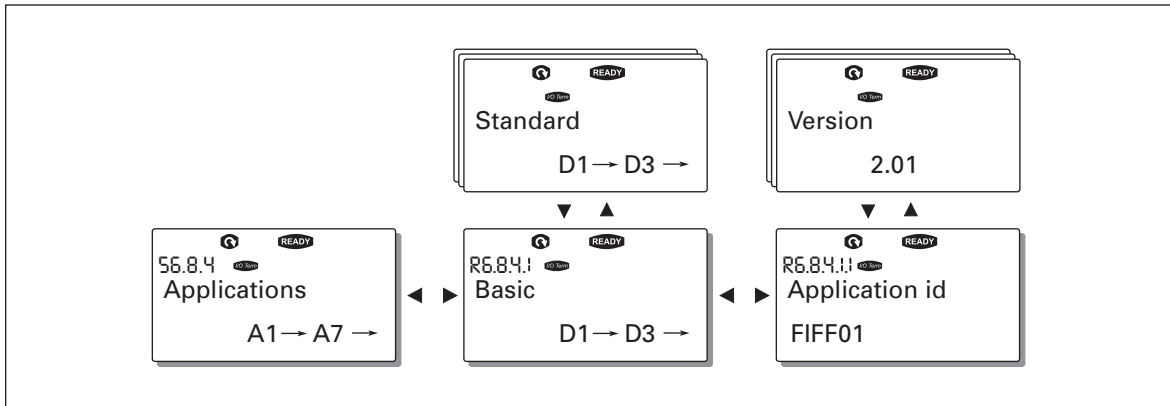
*Applications (S6.8.4)*

At location S6.8.4, you can find the Applications submenu containing information on the application currently in use and all other applications loaded into the drive. The following information is available:

**Table 5-15: Applications Information Pages**

Page	Counter
6.8.4.#	Name of application
6.8.4.#.1	Application ID
6.8.4.#.2	Version
6.8.4.#.3	Firmware interface

In the Applications information page, press Menu Button Right to enter the Application pages. There are as many Application pages as there are applications loaded into the drive. Locate the desired application with the Browser buttons and then enter the Information pages with Menu Button Right. Use the Browser buttons to see the different pages.



**Figure 5-25: Applications Info Submenu**

*Hardware (S6.8.5)*

The Hardware information page provides information on the following hardware-related topics:

**Table 5-16: Hardware Information Pages**

Page	Counter
6.8.5.1	Nominal power of the unit
6.8.5.2	Nominal voltage of the unit
6.8.5.3	Brake chopper
6.8.5.4	Brake resistor

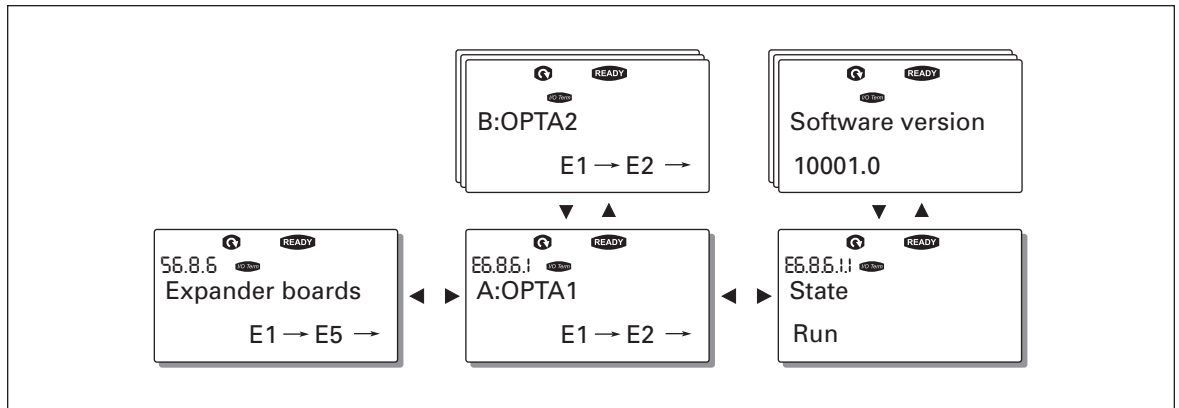
September 2007

*Expander Boards (S6.8.6)*

The Expander boards submenu contains information about the basic and option boards (see **Chapter 4**).

You can check the status of each board slot by entering the Expander Boards page with Menu Button Right. Use the Browser buttons to view the status of each board slot. The description line of the keypad will display the type of the expansion board and the text “Run” is shown below it. If no board is connected to the slot, the text “no board” will be shown. If a board is connected to a slot but the connection is lost for some reason, the text “no conn.” is displayed. For more information, see **Chapter 4**.

For more information on expander board related parameters, see below.



**Figure 5-26: Expander Board Information Menus**

*Debug Menu (S6.8.7)*

This menu is meant for advanced users and application designers. Contact Eaton for any assistance needed.

**Expander Board Menu (M7)**

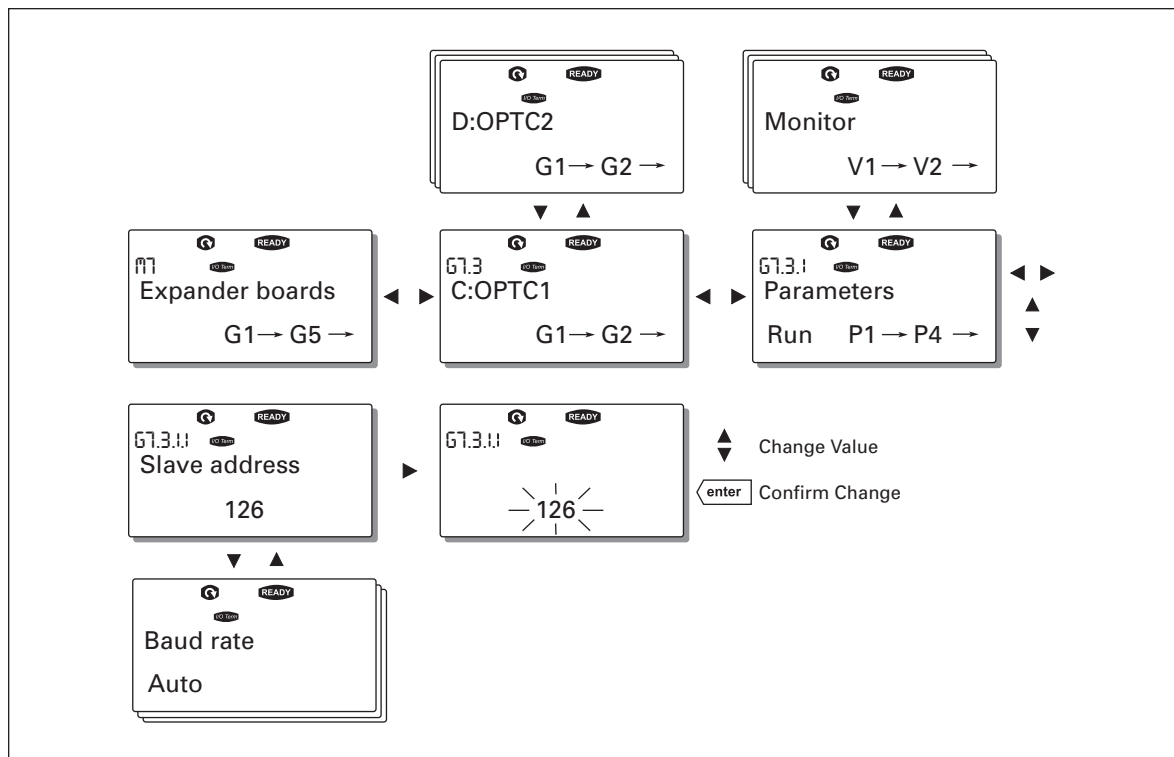
In the Expander board menu the user can 1) see the expander boards connected to the control board and 2) see and edit the parameters associated with the expander boards.

Go to the next menu level (G#) with Menu Button Right. At this level, you can browse through slots A to E with the Browser buttons to see which expander boards are connected to the control board. On the lowermost line of the display, you will also see the number of parameters associated with the board. You can view and edit the parameter values as described on **Page 5-8**. See **Table 5-17** and **Figure 5-27**.

**Expander Board Parameters**

**Table 5-17: Expander Board Parameters (Board OPTA1)**

Code	Parameter	Min	Max	Default	Cust	Selections
P7.1.1.1	AI1 mode	1	5	3		1 = 0 to 20 mA 2 = 4 to 20 mA 3 = 0 to 10V 4 = 2 to 10V 5 = -10 to +10 V
P7.1.1.2	AI2 mode	1	5	1		See P7.1.1.1
P7.1.1.3	AO1 mode	1	4	1		1 = 0 to 20 mA 2 = 4 to 20 mA 3 = 0 to 10V 4 = 2 to 10V



**Figure 5-27: Expander Board Information Menu**

**Further Keypad Functions**

The control keypad contains additional application-related functions. See the application manual for more information.

September 2007

## Chapter 6 — Start-Up

### Safety Precautions

Before start-up, note the following directions and warnings:

---

 **WARNING**

---

- 1** Internal components and circuit boards of the drive are live when the drive is connected to mains potential. **Coming into contact with this voltage is extremely dangerous and may cause death or severe injury.**
- 2** The motor terminals U, V, W and the DC-link/brake resistor terminals B+/R+, R- are **live** when the drive is connected to mains, **even if the motor is not running.**
- 3** The control I/O-terminals are isolated from the mains potential. However, the relay outputs and other I/O-terminals may have a dangerous control voltage present even when the drive is disconnected from mains.
- 4** Do not make any connections when the drive is connected to the mains.
- 5** After having disconnected the drive, wait until the indicators on the keypad go out (if no keypad is attached see the indicator through the keypad base). Wait 5 more minutes before doing any work on drive connections. Do not even open the cover before this time has expired.
- 6** Before connecting the drive to the mains, make sure that the coolant is circulating and has no leaks.
- 7** Before connecting the drive to the mains, make sure that the switchgear enclosure door is closed.

## Sequence of Operation

1. Carefully read the safety instructions in the front of this manual and above and follow them.
2. After the installation, make sure that:
  - both the drive and the motor are grounded.
  - the mains and motor cables comply with the requirements given in **Chapter 3**.
  - the control cables are located as far as possible from the power cables (see **Chapter 2**) and the shields of the shielded cables are connected to protective ground. The wires may not touch the electrical components of the drive.
  - the common inputs of digital input groups are connected to +24V or ground of the I/O terminal or the external supply.
3. Check liquid cooling connections and system operation.
  - Open the shut-off valves.
  - Check the quality and quantity of the cooling liquid (**Chapter 2**).
  - Ensure the proper operation of liquid circulation system.
4. Perform the cable and motor insulation checks, see **Page 3-14**.
5. Check the drive for condensation.
6. Check that all Start/Stop switches connected to the I/O terminals are in Stop position.
7. Connect the drive to mains.
8. Set the parameters of group 1 according to the requirements of your application (see application manual). At least the following parameters should be set:
  - motor nominal voltage
  - motor nominal frequency
  - motor nominal speed
  - motor nominal current

You will find the values needed for the parameters on the motor rating plate.



September 2007

9. Perform run test without motor.  
Perform either Test A or Test B:  
**Test A** — Controls from the I/O terminals:
  - Turn the Start/Stop switch to ON position.
  - Change the frequency reference (potentiometer).
  - Check in the Monitoring Menu M1 that the value of Output Frequency changes according to the change of frequency reference.
  - Turn the Start/Stop switch to OFF position.**Test B** — Control from the Control keypad:
  - Change the control from the I/O terminals to the keypad as advised on **Page 5-10**.
  - Press the START button on the keypad.
  - Move over to the Keypad Control Menu M3 and Keypad Reference submenu (see Keypad Reference on **Page 5-10**) and change the frequency reference with the Browser buttons.
  - Check in Monitoring Menu M1 that the value of Output Frequency changes according to the change of frequency reference.
  - Press the STOP button on the keypad.
10. Run the start-up tests without the motor being connected to the process, if possible. If this is not possible, make sure that running each test is safe prior to running it. Inform your co-workers of the tests.
  - Switch off the supply voltage and wait until the drive has stopped as advised on **Page 6-1, Safety Precautions**.
  - Connect the motor cable to the motor and to the motor cable terminals of the drive.
  - Make sure that all Start/Stop switches are in Stop positions.
  - Switch the supply voltage ON.
  - Repeat test 9A or 9B.
11. Connect the motor to the process (if the start-up test was run without the motor being connected).
  - Before running the tests, make sure that this can be done safely.
  - Inform your co-workers of the tests.
  - Repeat test 9A or 9B.



September 2007

## Appendix A — Fault Codes

When a fault is detected by the drive's control electronics, the drive is stopped and the symbol F together with the ordinal number of the fault, the fault code and a short fault description appear on the display. The fault can be reset with the RESET button on the control keypad or via the I/O terminal. The faults are stored in the Fault History Menu M5, which can be browsed. **Table A-1** contains all the fault codes.

**Table A-1: Fault Codes**

Fault Code	Fault	Possible Cause	Solution
1	Overcurrent	Drive has detected too high a current in the motor cable: <ul style="list-style-type: none"> <li>• sudden heavy load increase</li> <li>• short circuit in the motor cables</li> <li>• unsuitable motor</li> </ul>	Check loading. Check motor. Check cables.
2	Overvoltage	The DC-link voltage has exceeded the limits defined in <b>Table 1-6</b> : <ul style="list-style-type: none"> <li>• too short a deceleration time</li> <li>• high overvoltage spikes in supply</li> </ul>	Set the deceleration time longer. Add a brake chopper or brake resistor.
3	Ground Fault <sup>①</sup>	Current measurement has detected that the sum of motor phase currents is not zero. <ul style="list-style-type: none"> <li>• insulation failure in cables or motor</li> </ul>	Check motor cables and motor.
5	Charging Switch	The charging switch is open, when the START command has been given. <ul style="list-style-type: none"> <li>• faulty operation</li> <li>• component failure</li> </ul>	Reset the fault and restart. Should the fault re-occur, contact your Cutler-Hammer distributor.
6	Emergency stop	Stop signal has been given from the option board.	
7	Saturation trip	Various causes: <ul style="list-style-type: none"> <li>• component failure</li> <li>• brake resistor short circuit or overload</li> </ul>	Cannot be reset from the keypad. Switch off power. <b>DO NOT RE-CONNECT POWER!</b> Contact Eaton. If this fault appears simultaneously with Fault 1, check motor cables and motor.
8	System fault	<ul style="list-style-type: none"> <li>• component failure</li> <li>• faulty operation</li> </ul> <b>Note:</b> exceptional fault data record, see <b>Page 5-12</b> .	Reset the fault and restart. Should the fault reoccur, contact your Cutler-Hammer distributor.

<sup>①</sup> Programmable.

**Table A-1: Fault Codes (Continued)**

<b>Fault Code</b>	<b>Fault</b>	<b>Possible Cause</b>	<b>Solution</b>
9	Undervoltage <sup>①</sup>	DC-link voltage is under the voltage limits defined in <b>Table 1-6</b> . <ul style="list-style-type: none"> <li>most probable cause: too low a supply voltage</li> <li>drive internal fault</li> </ul>	In case of temporary supply voltage break, reset the fault and restart the drive. Check the supply voltage. If it is adequate, an internal failure has occurred. Contact your Cutler-Hammer distributor.
10	Input line supervision <sup>①</sup>	Input line phase is missing.	Check supply voltage and cable.
11	Output phase supervision <sup>①</sup>	Current measurement has detected that there is no current in one motor phase.	Check motor cable and motor.
12	Brake chopper supervision	<ul style="list-style-type: none"> <li>no brake resistor installed</li> <li>brake resistor is broken</li> <li>brake chopper failure</li> </ul>	Check brake resistor. If the resistor is ok, the chopper is faulty. Contact your Cutler-Hammer distributor.
13	Drive undertemperature	Heatsink temperature is under 14°F (-10°C)	
14	Drive overtemperature	<ul style="list-style-type: none"> <li>Heatsink temperature is over 158°F (70°C). Overtemperature warning is issued when the heatsink temperature exceeds 149°F (65°C).</li> <li>Circuit board temperature is over 185°F (85°C). Overtemperature warning is issued when the board temperature exceeds 158°F (70°C).</li> </ul>	Check that values for $I_{th}$ ( <b>Page 1-7</b> ) are not exceeded. Check the correct coolant flow and temperature. Also check the circulation for possible leaks. Check the ambient temperature. Make sure that the switching frequency is not too high in relation to ambient temperature and motor load. Circulation of air in the drive is blocked. The cooling fans are defective.
15	Motor stalled <sup>①</sup>	Motor stall protection has tripped.	Check motor.
16	Motor overtemperature <sup>①</sup>	<ul style="list-style-type: none"> <li>motor overheating has been detected by drive motor temperature model</li> <li>motor is overloaded</li> </ul>	Decrease the motor load. If no motor overload exists, check the temperature model parameters.
17	Motor underload <sup>①</sup>	Motor underload protection has tripped.	
22	EEPROM checksum fault <sup>②</sup>	Parameter save fault <ul style="list-style-type: none"> <li>faulty operation</li> <li>component failure</li> </ul>	
24	Counter fault	Values displayed on counters are incorrect.	
25	Microprocessor watchdog fault	<ul style="list-style-type: none"> <li>faulty operation</li> <li>component failure</li> </ul>	Reset the fault and restart. Should the fault re-occur, contact your Cutler-Hammer distributor.
26	Start-up prevented	Start-up of the drive has been prevented.	Cancel prevention of start-up.

<sup>①</sup> Programmable.

<sup>②</sup> "A" faults only

September 2007

**Table A-1: Fault Codes (Continued)**

<b>Fault Code</b>	<b>Fault</b>	<b>Possible Cause</b>	<b>Solution</b>
29	Thermistor fault <sup>①</sup>	The thermistor input of option board has detected increase of the motor temperature.	Check motor cooling and loading Check thermistor connection (If thermistor input of the option board is not in use, it has to be short circuited)
31	IGBT temperature (hardware)	IGBT Inverter Bridge overtemperature protection has detected too high a short term overload current.	Check loading. Check motor size.
34	CAN bus communication	Sent message not acknowledged.	Ensure that there is another device on the bus with the same configuration.
36	Control unit	Control Unit can not control Power Unit and vice versa.	Change control unit.
37	Device change (same type) <sup>②</sup>	<ul style="list-style-type: none"> <li>option board or control unit changed.</li> <li>same type of board or same power rating of drive</li> </ul>	Reset <b>Note:</b> No fault time data record!
38	Device added (same type) <sup>②</sup>	<ul style="list-style-type: none"> <li>option board or drive added.</li> <li>drive of same power rating or same type of board added</li> </ul>	Reset <b>Note:</b> No fault time data record!
39	Device removed <sup>②</sup>	<ul style="list-style-type: none"> <li>option board removed</li> <li>drive removed</li> </ul>	Reset <b>Note:</b> No fault time data record!
40	Device unknown	Unknown option board or drive.	Contact your Cutler-Hammer distributor.
41	IGBT temperature	IGBT Inverter Bridge overtemperature protection has detected too high a short term overload current.	Check loading. Check motor size.
42	Brake resistor overtemperature <sup>①</sup>	Brake resistor overtemperature protection has detected too heavy braking.	Set the deceleration time longer. Use external brake resistor.
43	Encoder fault	<p><b>Note:</b> the exceptional fault data record, see <b>Page 5-12</b>. Additional codes:</p> <p><b>1</b> = Encoder 1 channel A is missing  <b>2</b> = Encoder 1 channel B is missing  <b>3</b> = Both encoder 1 channels are missing  <b>4</b> = Encoder reversed</p>	Check encoder channel connections. Check the encoder board.
44	Device changed (different type) <sup>②</sup>	<ul style="list-style-type: none"> <li>option board or control unit changed</li> <li>option board of different type or different power rating of drive</li> </ul>	Reset. <b>Note:</b> No Fault Time Data Record is made. <b>Note:</b> Application parameter values restored to default.

<sup>①</sup> Programmable.

<sup>②</sup> "A" faults only.

**Table A-1: Fault Codes (Continued)**

Fault Code	Fault	Possible Cause	Solution
45	Device added (different type) <sup>②</sup>	<ul style="list-style-type: none"> <li>option board or device added</li> <li>option board of different type or drive of different power rating added</li> </ul>	Reset. <b>Note:</b> No Fault Time Data Record is made. <b>Note:</b> Application parameter values restored to default.
50	Analog input sel. signal range 4 to 20 mA) <sup>①</sup>	Current at the analog input is <4 mA. <ul style="list-style-type: none"> <li>control cable is broken or loose</li> <li>signal source has failed.</li> </ul>	Check the current loop, signal source and wiring.
51	External fault	Digital input failed.	Check source of trigger.
52	Keypad communication fault	There is no connection between the control keypad and the drive.	Check the keypad connection and keypad cable.
53	Fieldbus fault	The data connection between the fieldbus master and the fieldbus board is broken.	Check installation. If installation is correct contact your Cutler-Hammer distributor.
54	Slot fault	Defective option board or slot.	Check that the board is properly installed and seated in slot. If the installation is correct, contact your Cutler-Hammer distributor.
56	PT100 board temperature fault	Temperature limit values set for the PT100 board parameters have been exceeded.	Determine the cause of the high temperature.

<sup>①</sup> Programmable.

<sup>②</sup> "A" faults only.

## Load Test with Motor

1. Connect the motor cables and check the right phase order. Also check that the motor rotates freely.
2. Check liquid cooling system operation
3. Turn on the supply voltage and ensure that all input phases are connected to the unit.
4. Check DC link voltage by measuring with multimeter and compare the value to the one on monitoring page V1.8.
5. Select the application of your choice and set the needed parameters.
6. Start the operation with lower Current Limit value and long Acceleration/Deceleration times.
7. If Closed Loop control mode is used, check direction of encoder and make necessary Closed Loop parameter settings. Check the correct operation of the encoder by running the system in open loop and check the signals in the expander board menu.
8. Run the motor without load between minimum and maximum frequencies and check the unit output current with a current clamp. Compare the value to the one on monitoring page V1.4.
9. Load the motor to nominal value if possible and repeat the current measurement. Follow the Unit Temperature value on page V1.9.

September 2007

## DC Link Test (without Motor)

---

** WARNING**

---

There will be dangerous voltages present during this test!

1. Carefully read the safety instructions in the front of this manual and above and follow them.
2. Connect a variable DC power supply to DC+ and DC- terminals. Make sure that all polarities are correct.
3. Slowly charge up the DC link to nominal voltage. Allow the system to remain at this level for at least one minute and check current.
4. If possible, continue increasing the DC link voltage up to the trip limit. Fault F2 (see **Table A-1**) should occur at 911V DC (400 – 500V units) and at 1200V DC (525 – 690V units). Do not increase the voltage over the trip limit.
5. Bring the power supply voltage back to zero. Allow sufficient time for the capacitors to discharge.
6. Check the DC bus voltage with a multimeter. When you read zero volts, disconnect the power supply and reconnect all wires to the phase module.
7. If the phase module has been de-energized for an extended period of time (six months or longer) allow this voltage to remain for a minimum of 30 minutes — even 4 hours if time permits.

Through the above test procedure, two things are achieved: 1) It allows the caps to partially reform due to storage and shipping; 2) It allows any device failures to evidence themselves with a low power failure.

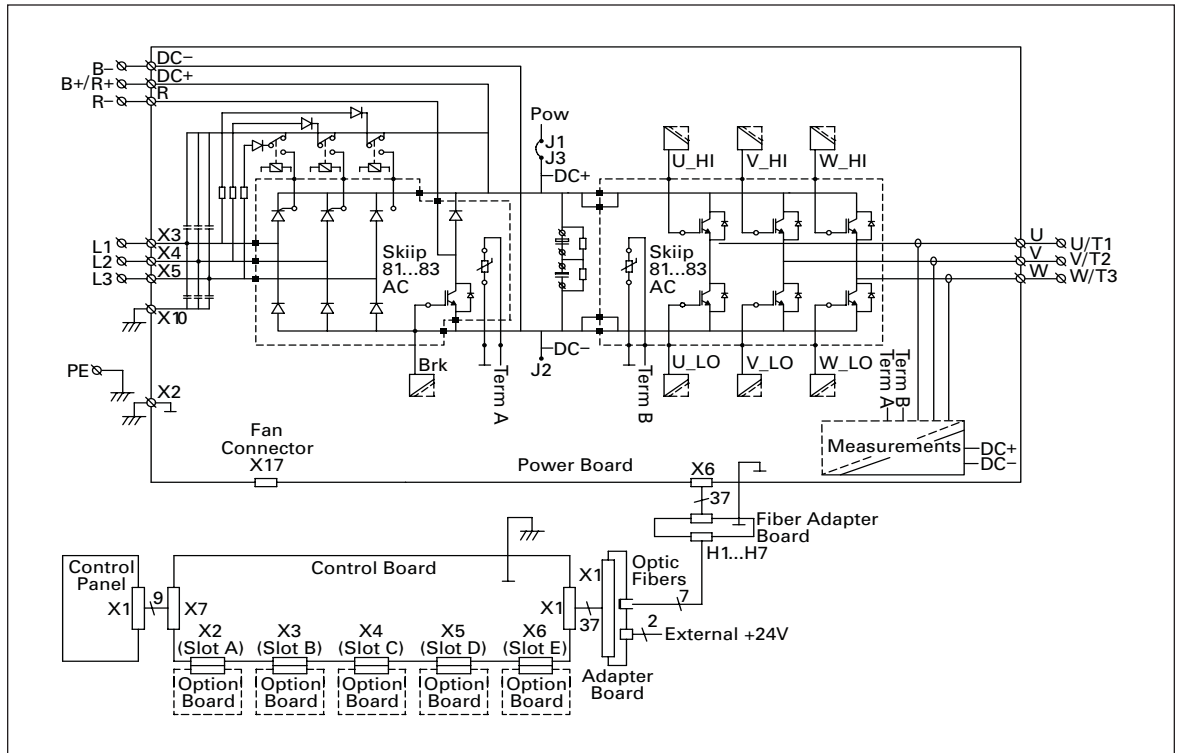




September 2007

## Appendix B — Technical Reference

### Main Circuit and Control Diagrams



**Figure B-1: Main Circuit and Control Diagram, CH3**

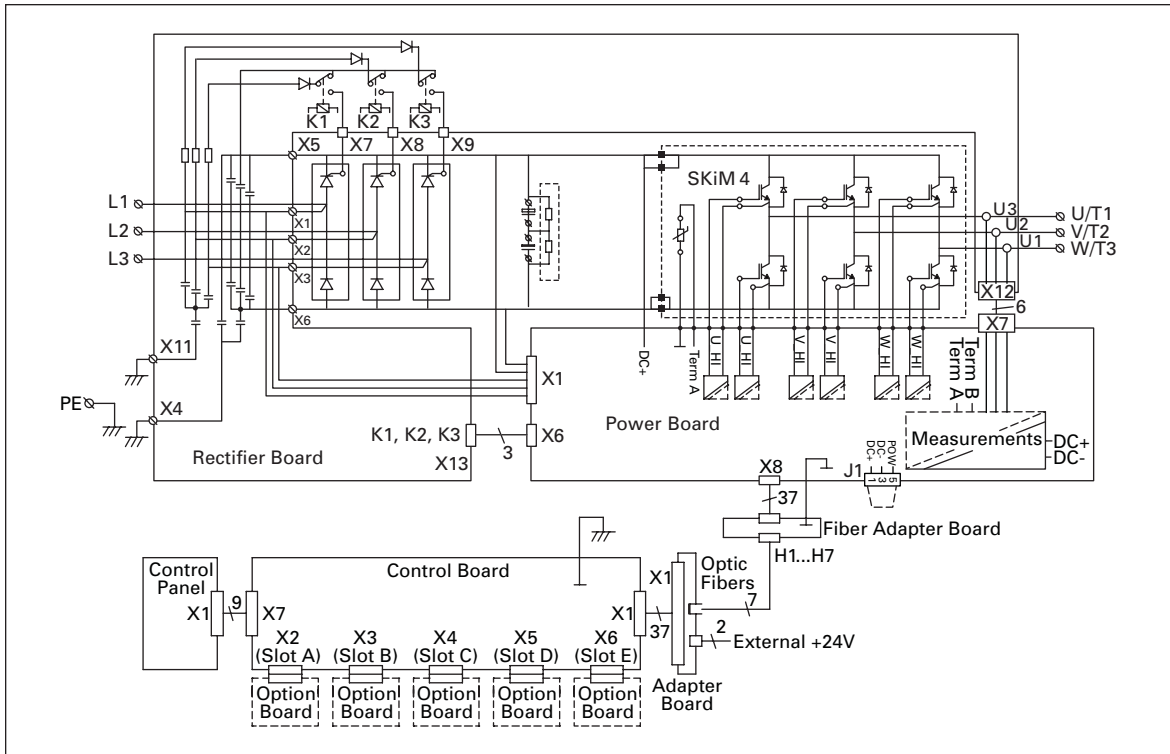


Figure B-2: Main Circuit and Control Diagram, CH4

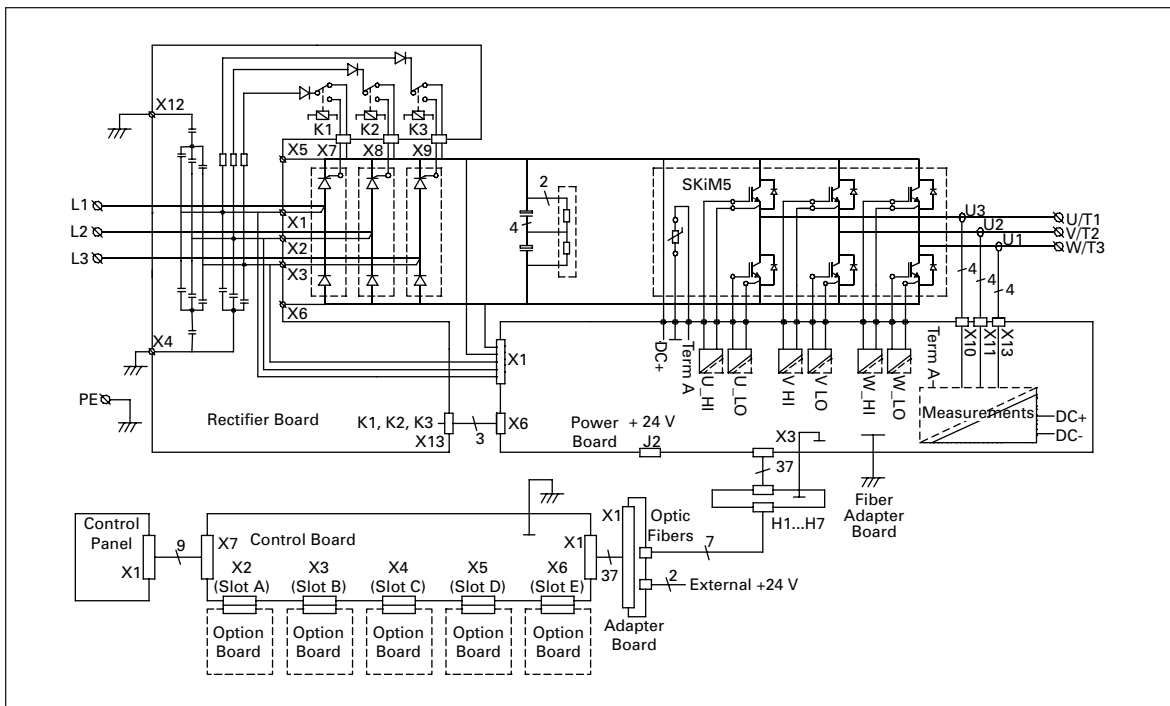


Figure B-3: Main Circuit and Control Diagram, CH5

September 2007

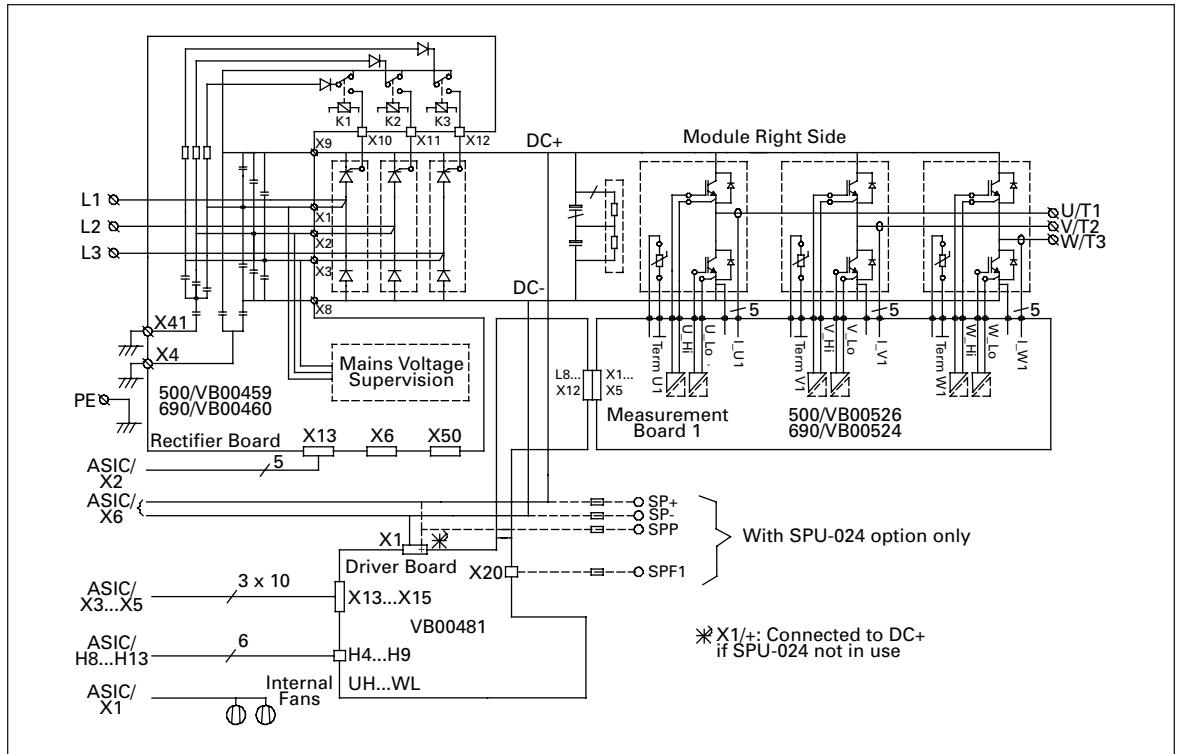


Figure B-4: Main Circuit and Control Diagram, CH61

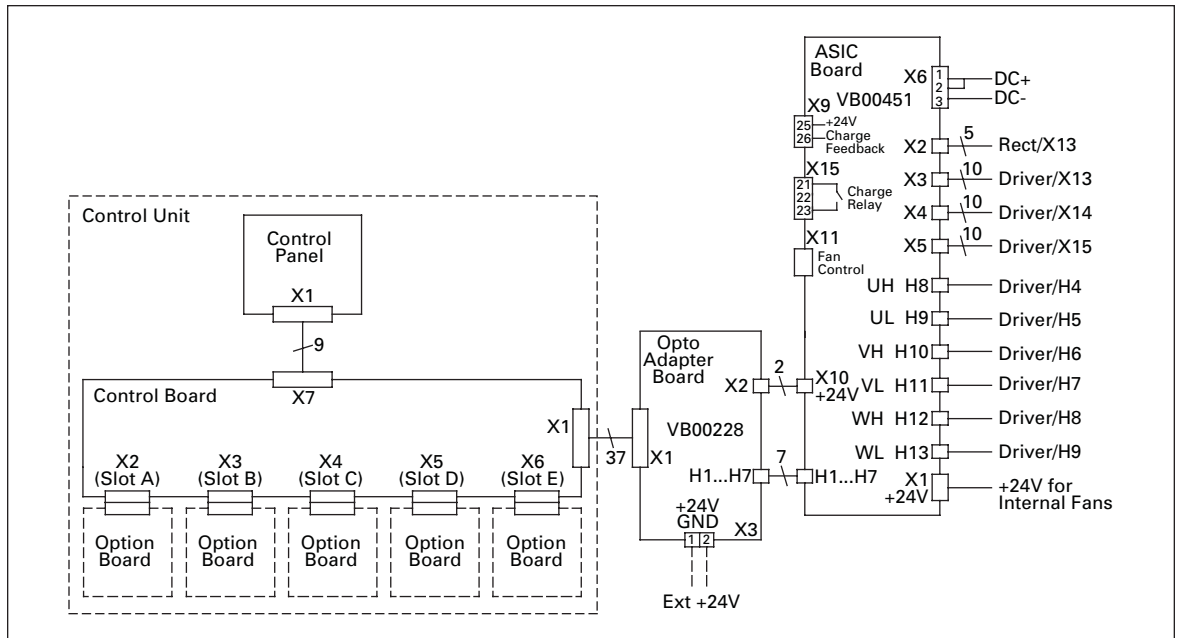


Figure B-5: Main Circuit and Control Diagram, CH61, Control

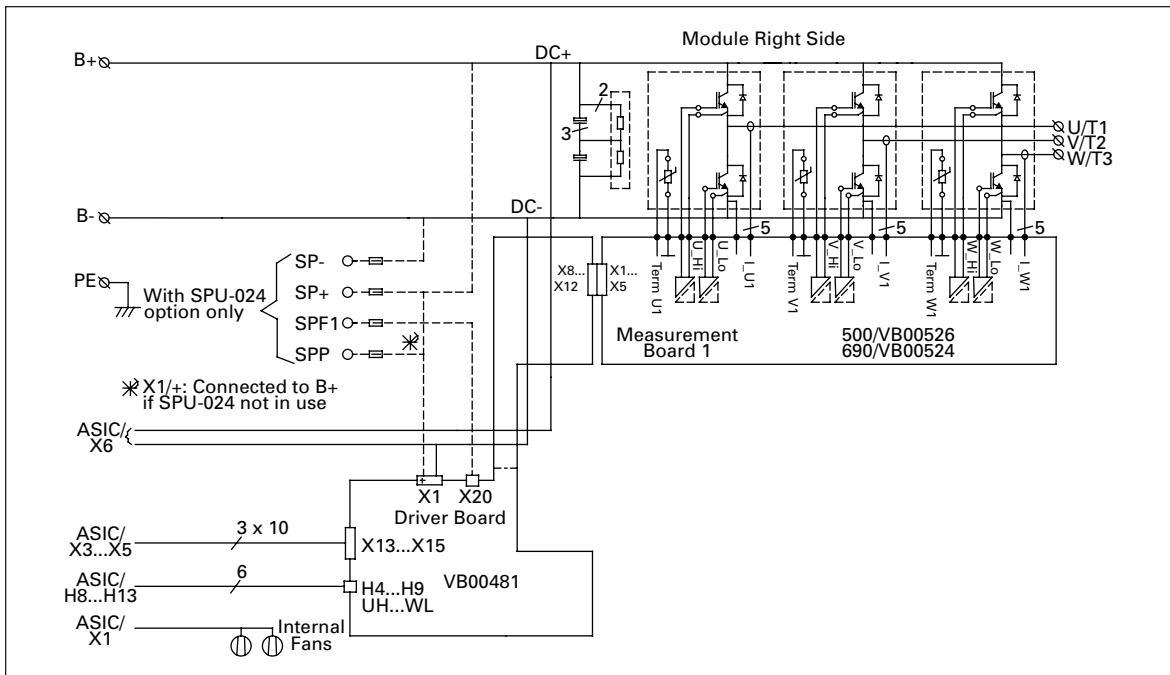


Figure B-6: Inverter Circuit Diagram, CH61

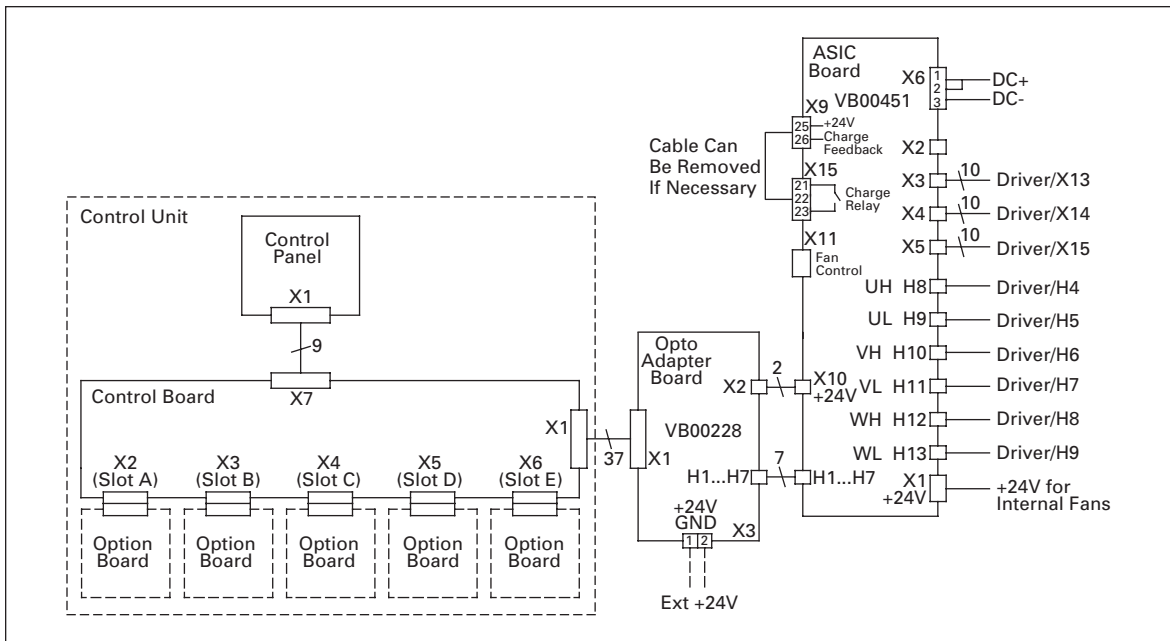
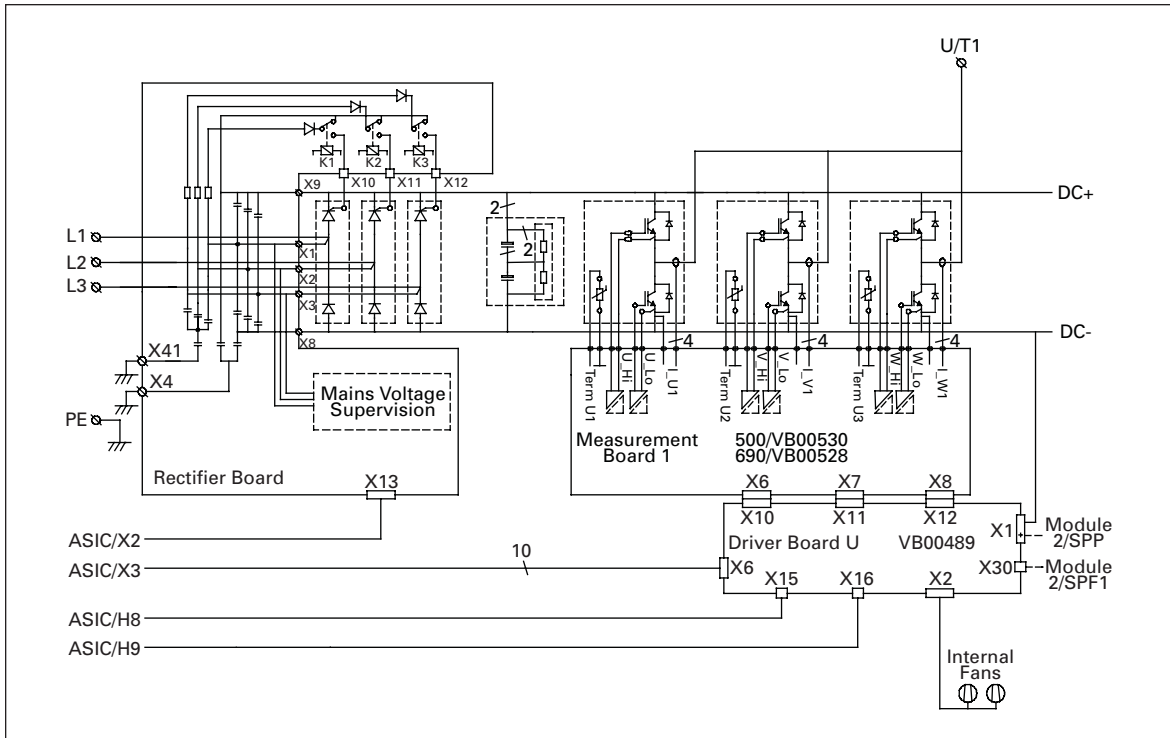
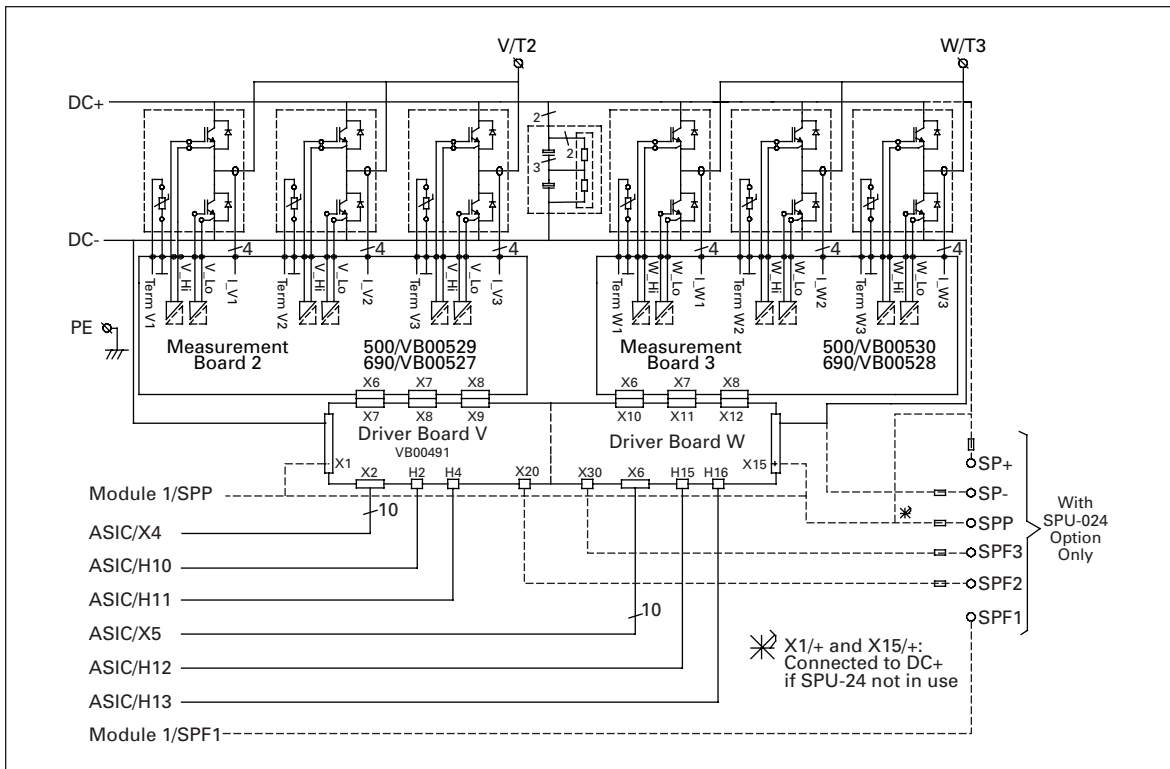


Figure B-7: Inverter Circuit and Control Diagram, CH61





**Figure B-10: Main Circuit and Control Diagram, CH63, Module 1**



**Figure B-11: Main Circuit and Control Diagram, CH63, Module 2**

September 2007

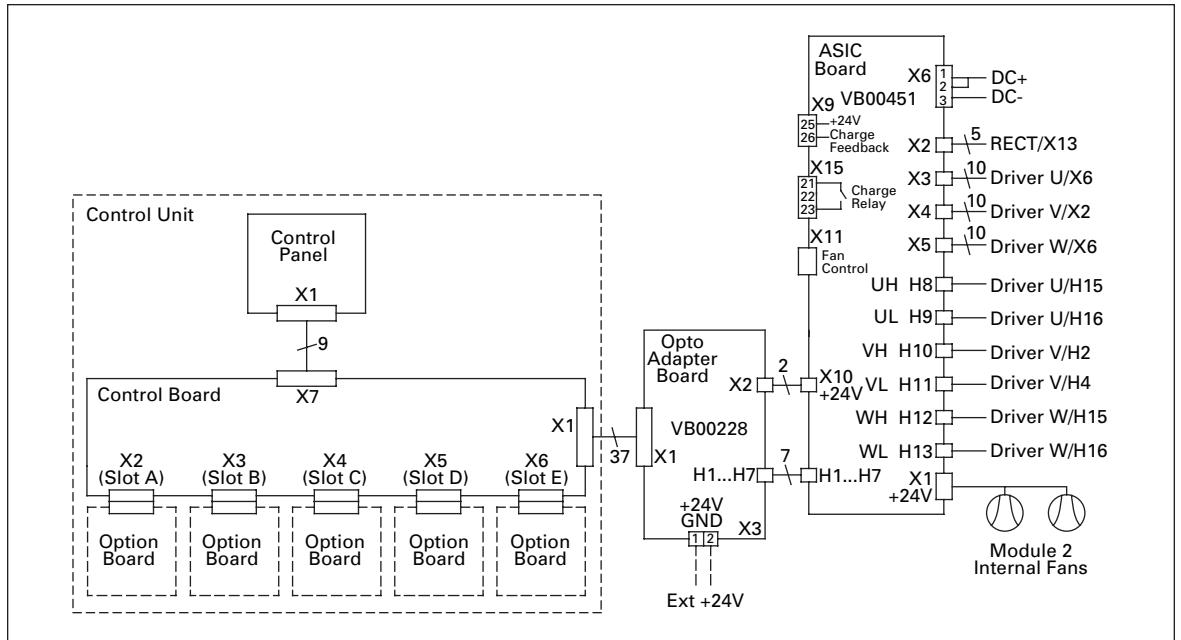


Figure B-12: Main Circuit and Control Diagram, CH63, Control

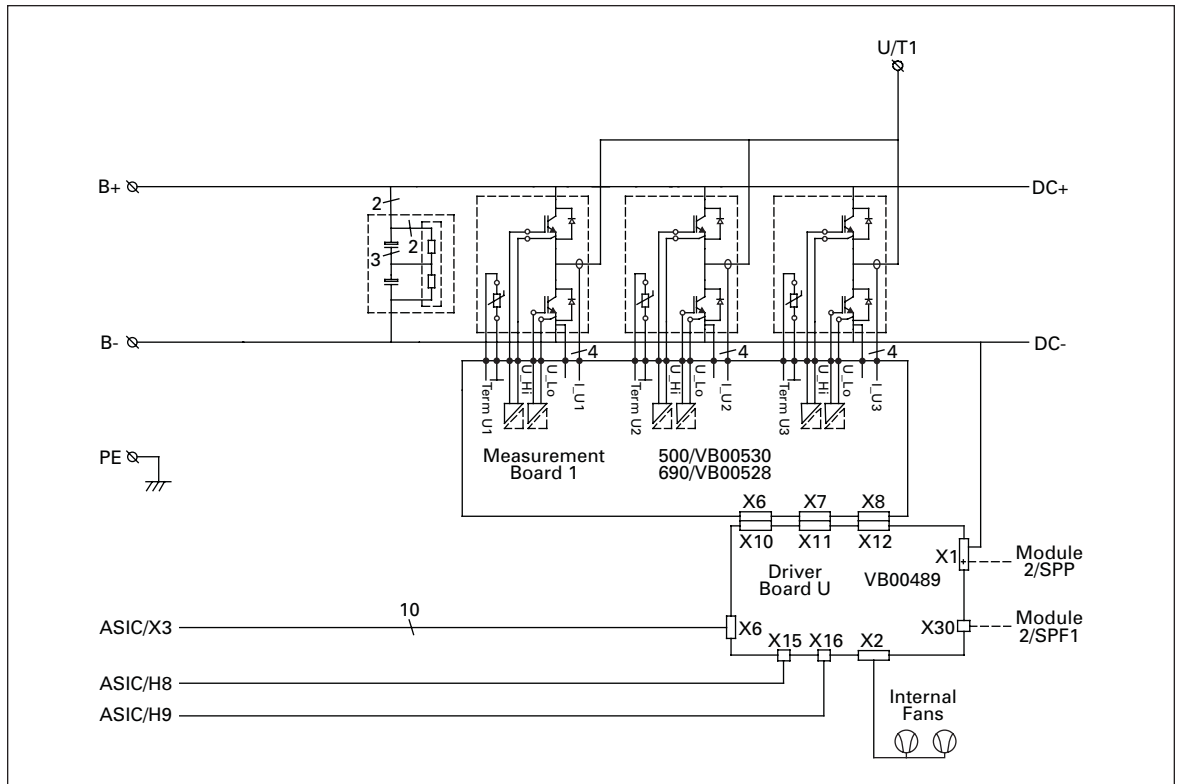


Figure B-13: Inverter Circuit Diagram, CH63, Module 1

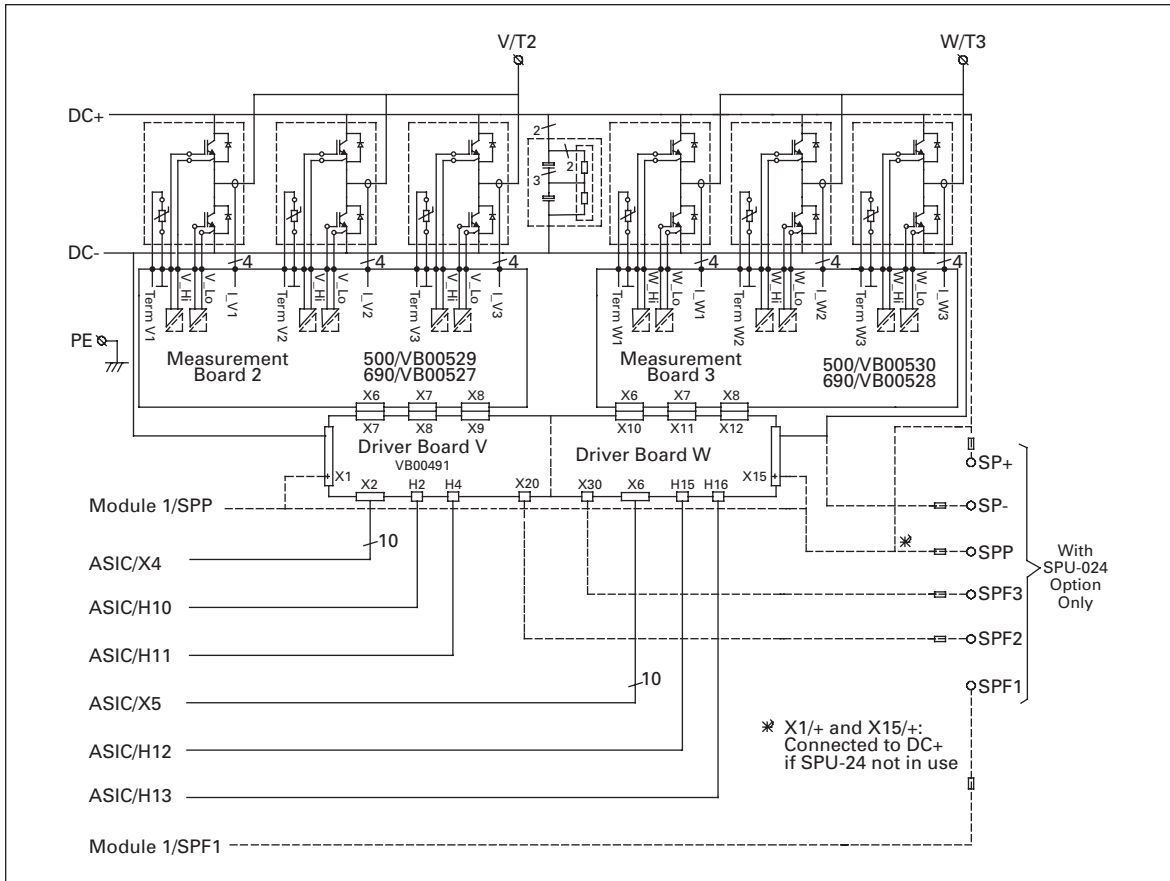


Figure B-14: Inverter Circuit Diagram, CH63, Module 2

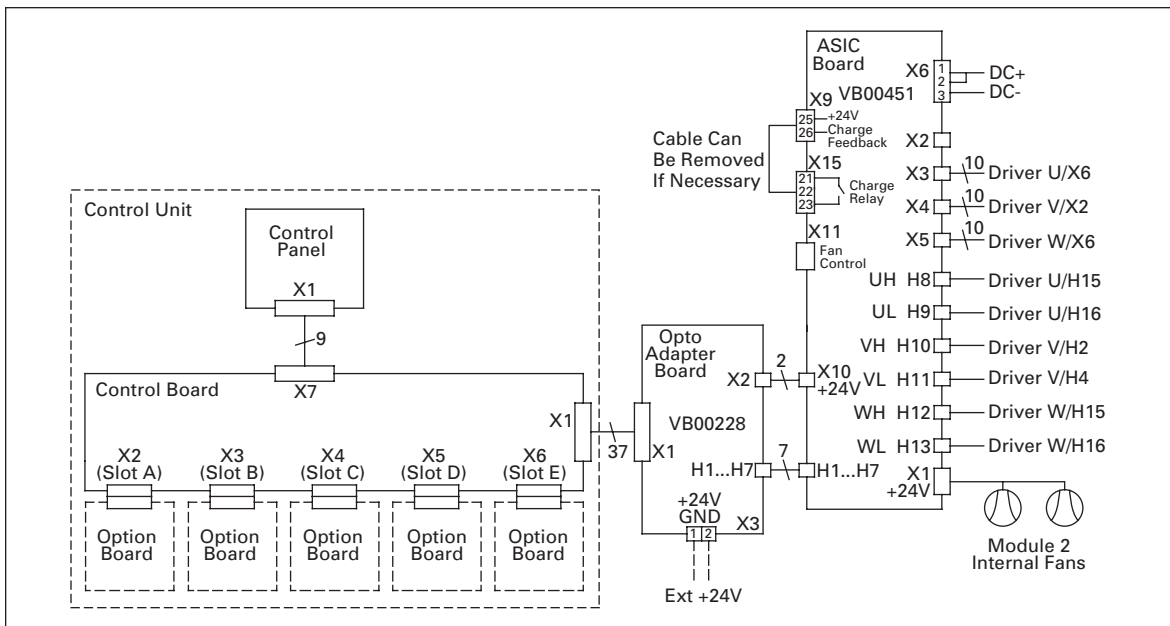


Figure B-15: Inverter Circuit Diagram, CH63, Control



September 2007

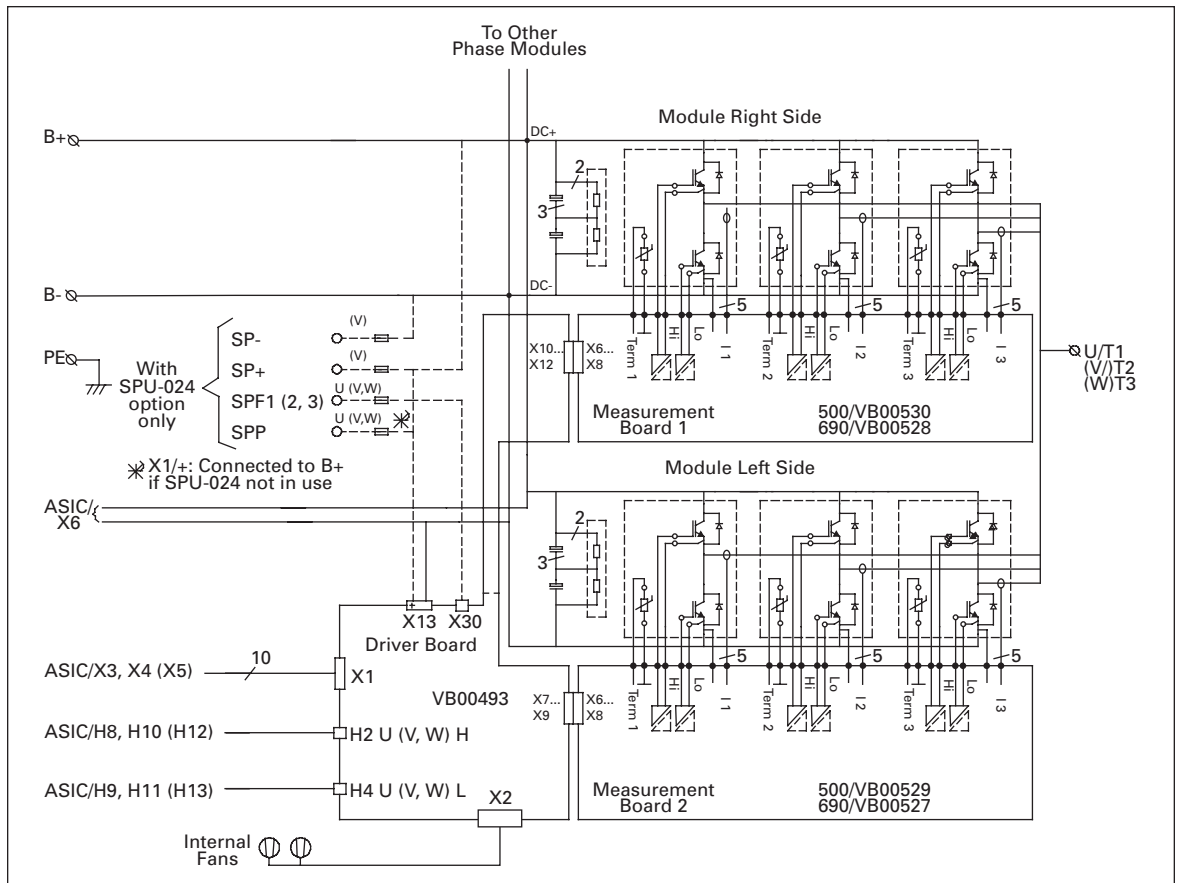


Figure B-16: Inverter Circuit Diagram, CH64, Phase U

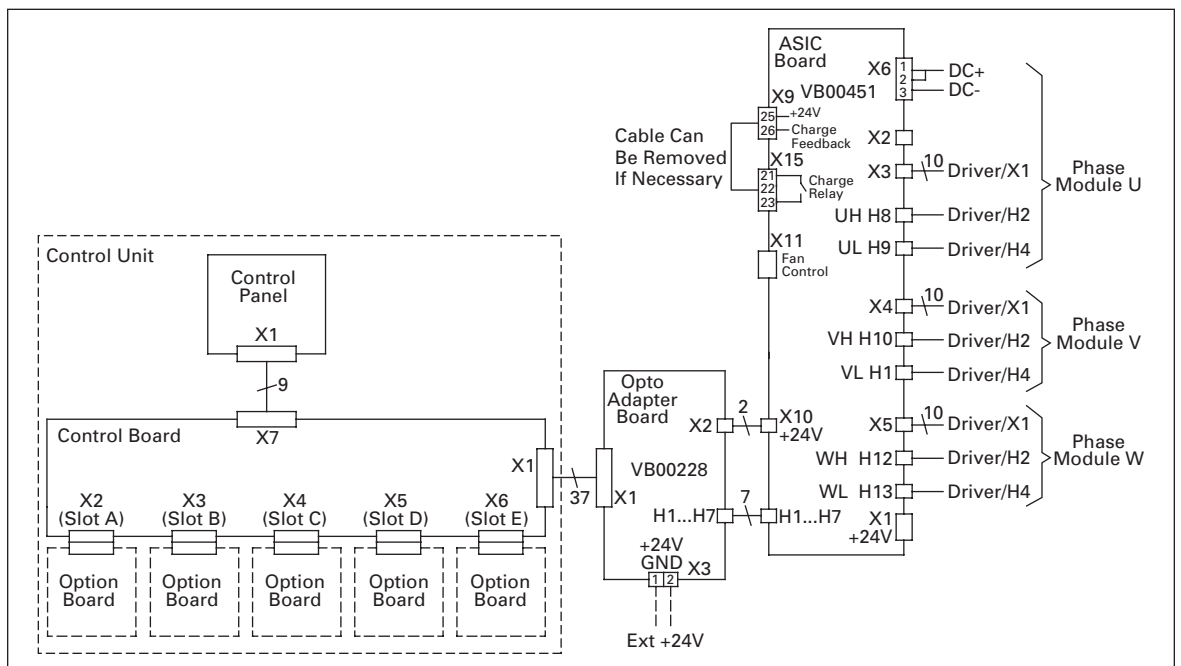


Figure B-17: Inverter Circuit Diagram, CH64, Control

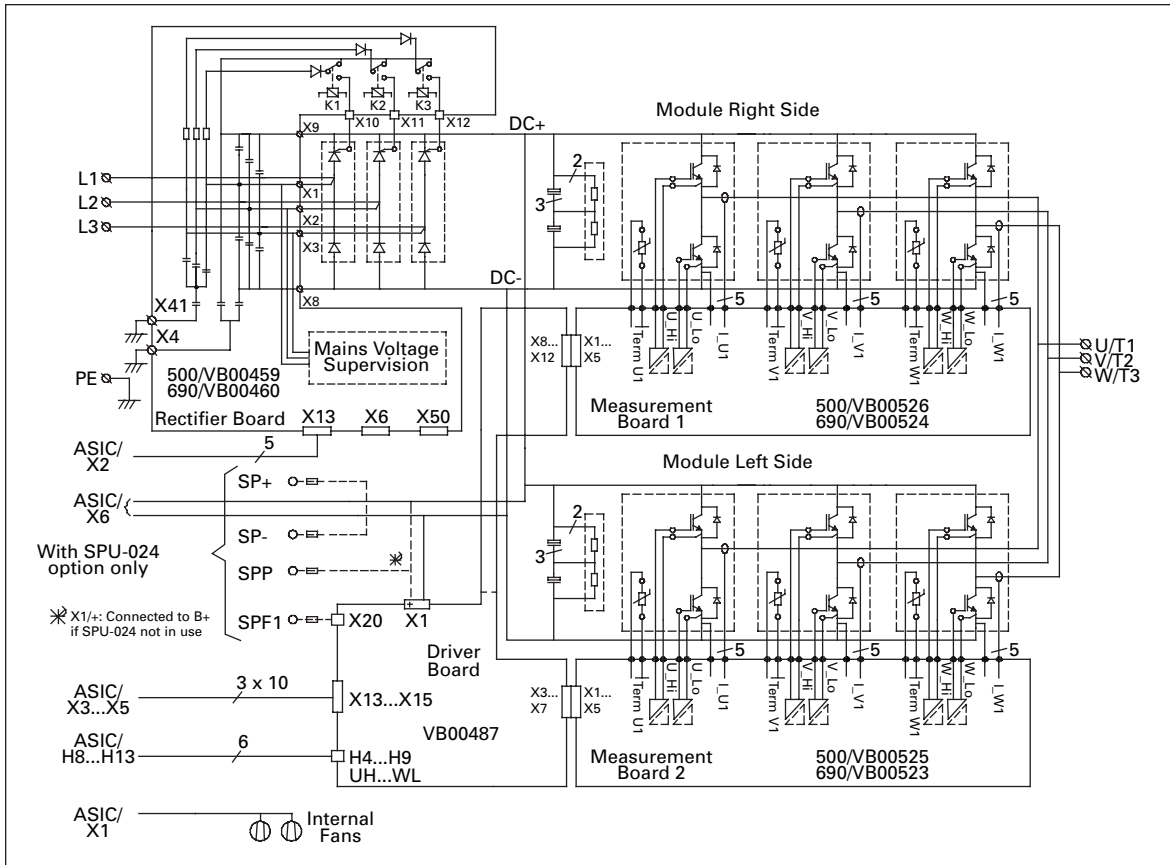


Figure B-18: Main Circuit and Control Diagram, CH72

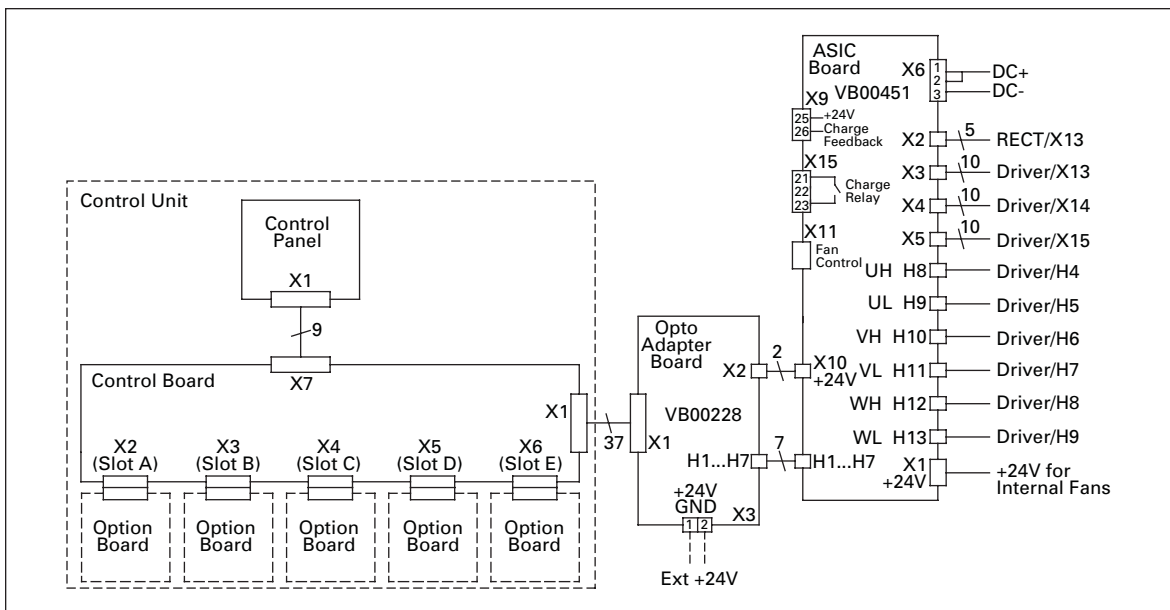
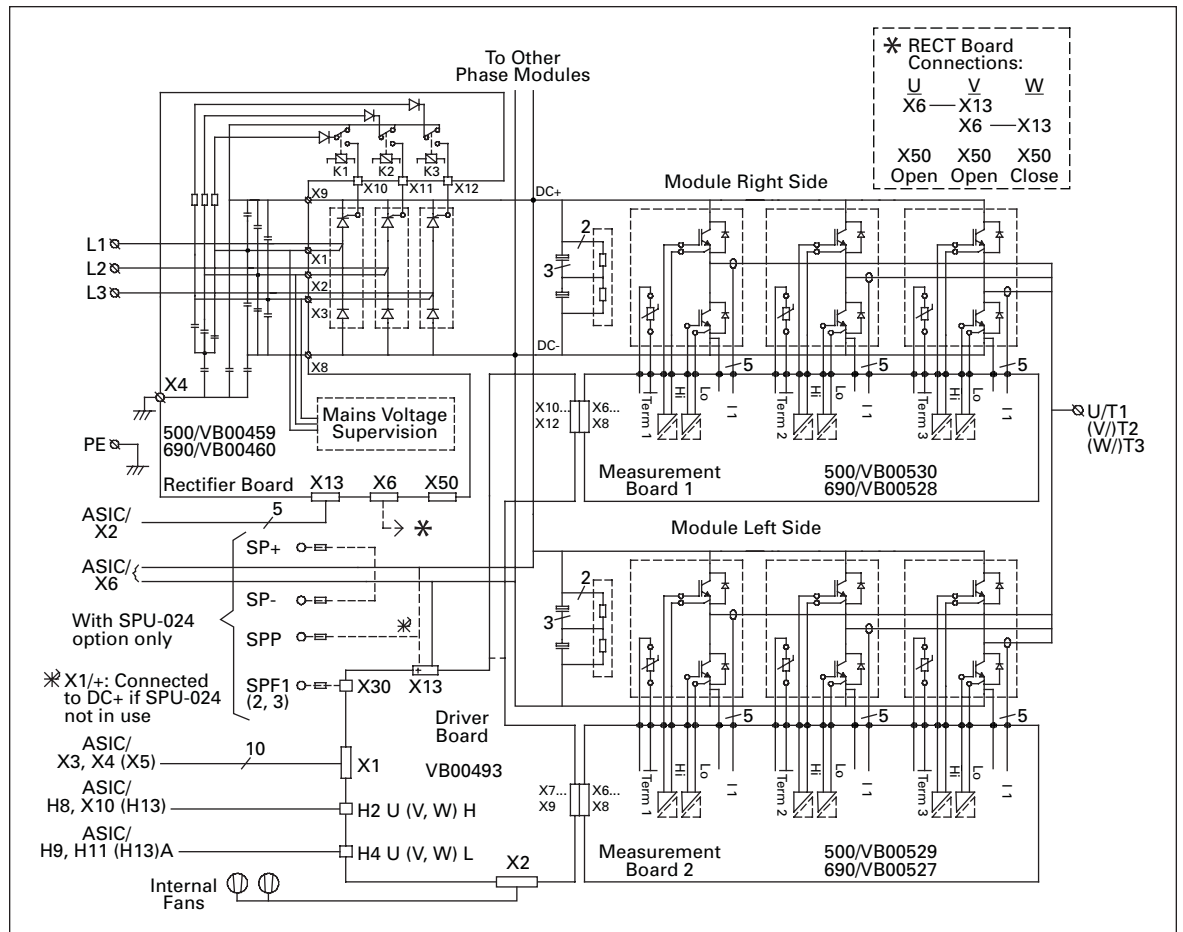
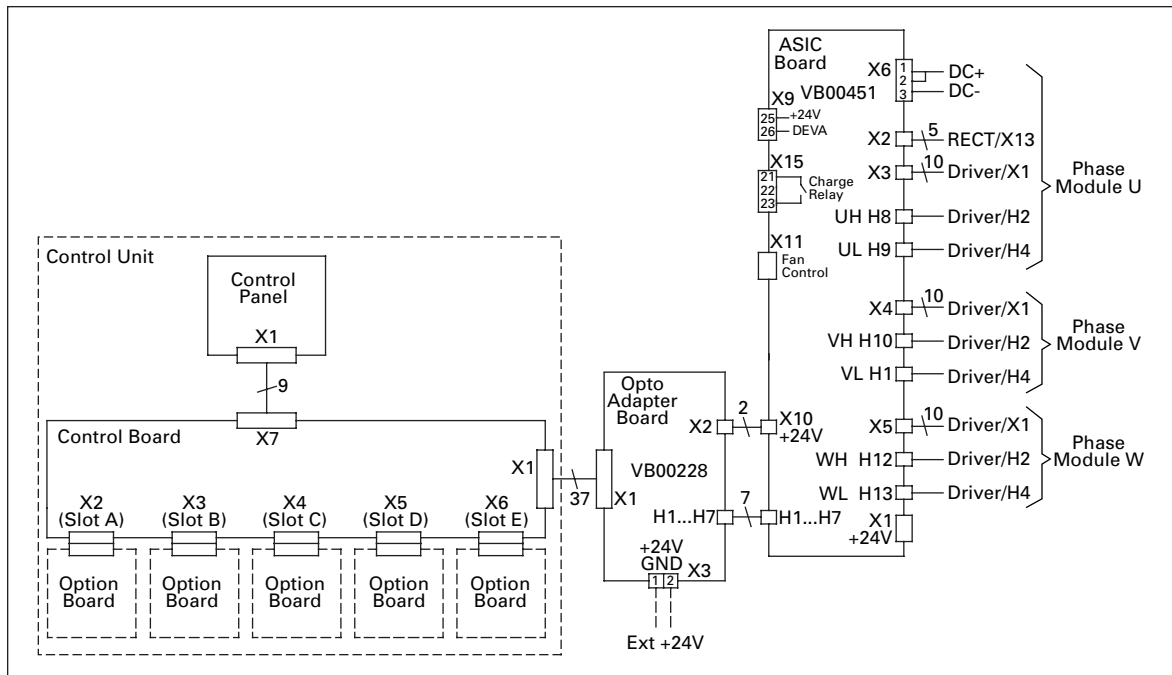


Figure B-19: Main Circuit and Control Diagram, CH72, Control

September 2007





**Figure B-21: Main Circuit and Control Diagram, CH74, Control**







## Company Information

Eaton's electrical business is a global leader in electrical control, power distribution, uninterruptible power supply and industrial automation products and services. Eaton's global electrical brands, including Cutler-Hammer®, Powerware®, Holec® and MEM®, provide customer-driven PowerChain Management™ solutions to serve the power system needs of the industrial, institutional, government, utility, commercial, residential, IT, mission critical and OEM markets worldwide.

Eaton Corporation is a diversified industrial manufacturer with 2006 sales of \$12.4 billion. Eaton is a global leader in electrical systems and components for power quality, distribution and control; fluid power systems and services for industrial, mobile and aircraft equipment; intelligent truck drivetrain systems for safety and fuel economy; and automotive engine air management systems, powertrain solutions and specialty controls for performance, fuel economy and safety. Eaton has 62,000 employees and sells products to customers in more than 125 countries. For more information, visit [www.eaton.com](http://www.eaton.com).

Eaton Corporation  
Electrical Group  
1000 Cherrington Parkway  
Moon Township, PA 15108  
United States  
877-ETN CARE (877-386-2273)  
Eaton.com

**EAT•N**

**Cutler-Hammer**

© 2007 Eaton Corporation  
All Rights Reserved  
Printed in USA  
Publication No. MN04005001E/CPG  
September 2007