

12 11 10 9 8 7 6 5 4 3 2 1

H
G
F
E
D
C
B
A

H
G
F
E
D
C
B
A

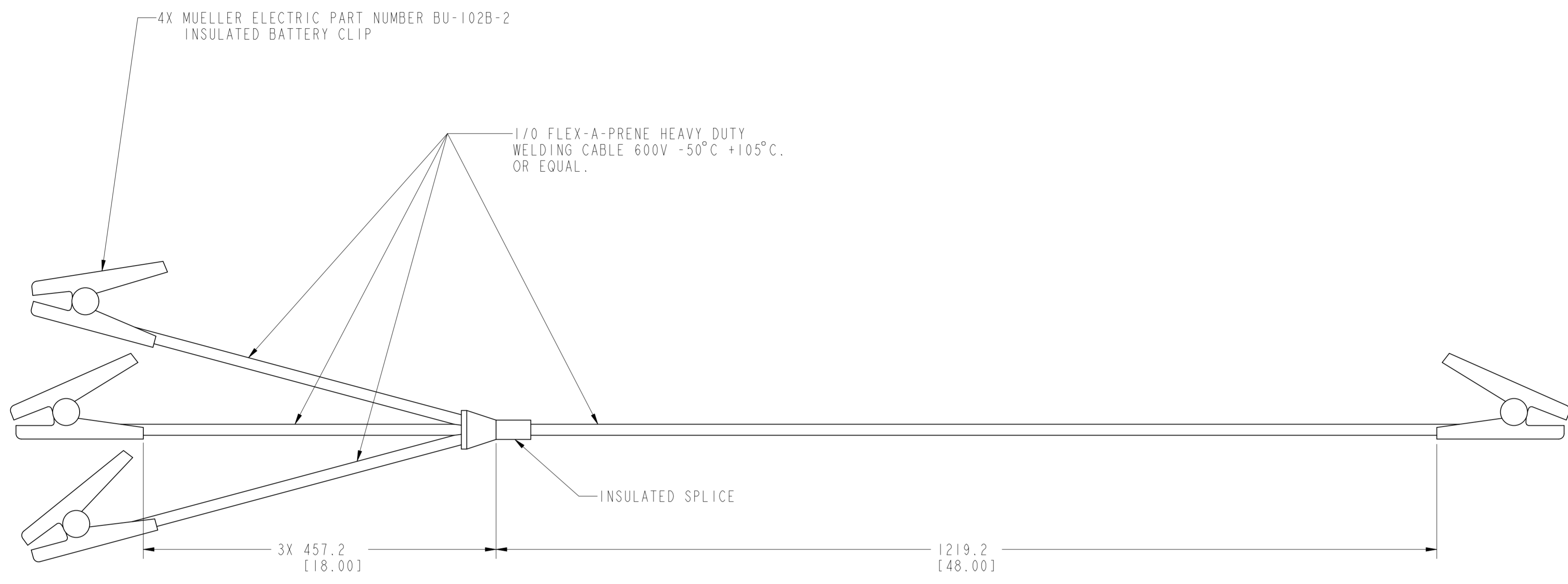

SCALE 1:4

NOTES:

1. APPROVED SUPPLIERS:
MERCURY ELECTRONICS
3846 GREEN VALLEY RD.
SEVEN VALLEYS, PA 17360
PH: 717-428-0222
FAX: 717-428-0333
2. USE HARNESS TO SHORT AND GROUND TERMINALS WHEN SERVICING ELECTRICAL CONNECTIONS OR DRIVE, WHILE COMPRESSOR IS ATTACHED TO A CHARGED CHILLER, SHORTING WILL APPLY BRAKING ACTION AND ELIMINATE STRAY VOLTAGE. ALL TERMINALS MUST BE GROUNDED, MOTORS WITH SIX TERMINALS REQUIRE USE OF TWO HARNESSES.

INTERPRET DIMENSIONING AND TOLERANCING PER ASME Y14.5M-1994

FIRST ANGLE	Johnson Controls		JOHNSON CONTROLS - BUILDING EFFICIENCY			
	507 EAST MICHIGAN STREET, MILWAUKEE, WI, 53202 USA					
DO NOT SCALE DIMENSIONS IN MM (DIMENSIONS IN INCH)			HARNESS GROUNDING		MATERIAL	
DRAWN D. T. KYDE 16-NOV-2011			ENG. STD.		PART NO.	
MODELER D. T. KYDE 16-NOV-2011			CAGE NUMBER		DRAWING NUMBER	
CHKD D. T. KYDE 16-NOV-2011			A2 66935		325-44935-000	
ENG			ORIG. NO.:		REVISION A	
SCALE: 2:25			MASS (kg): 9.692		VERSION 1	
			SHEET 1 OF 2		RELEASED	

REV.	DATE	EC. NO.	DR.	CHK.	ENG.	
A	08-MAY-2013	0913-3010	DTK	DTK	SJE	
SHEET 1: ADDED NOTE 2.						
SHEET 2: ADDED THIS SHEET.						
ALL PROPRIETARY RIGHTS IN THE SUBJECT MATTER HEREOF ARE RESERVED AND NO PERMISSION IS GRANTED TO REPRODUCE THIS PRINT IN WHOLE OR IN ANY PART, OR DISCLOSE ANY OF THE INFORMATION UPON IT TO OTHERS WITHOUT WRITTEN RELEASE BY JOHNSON CONTROLS INCORPORATED						

12 11 10 9 8 7 6 5 4 3 2 1

12 11 10 9 8 7 6 5 4 3 2 1

H
G
F
E
D
C
B
A

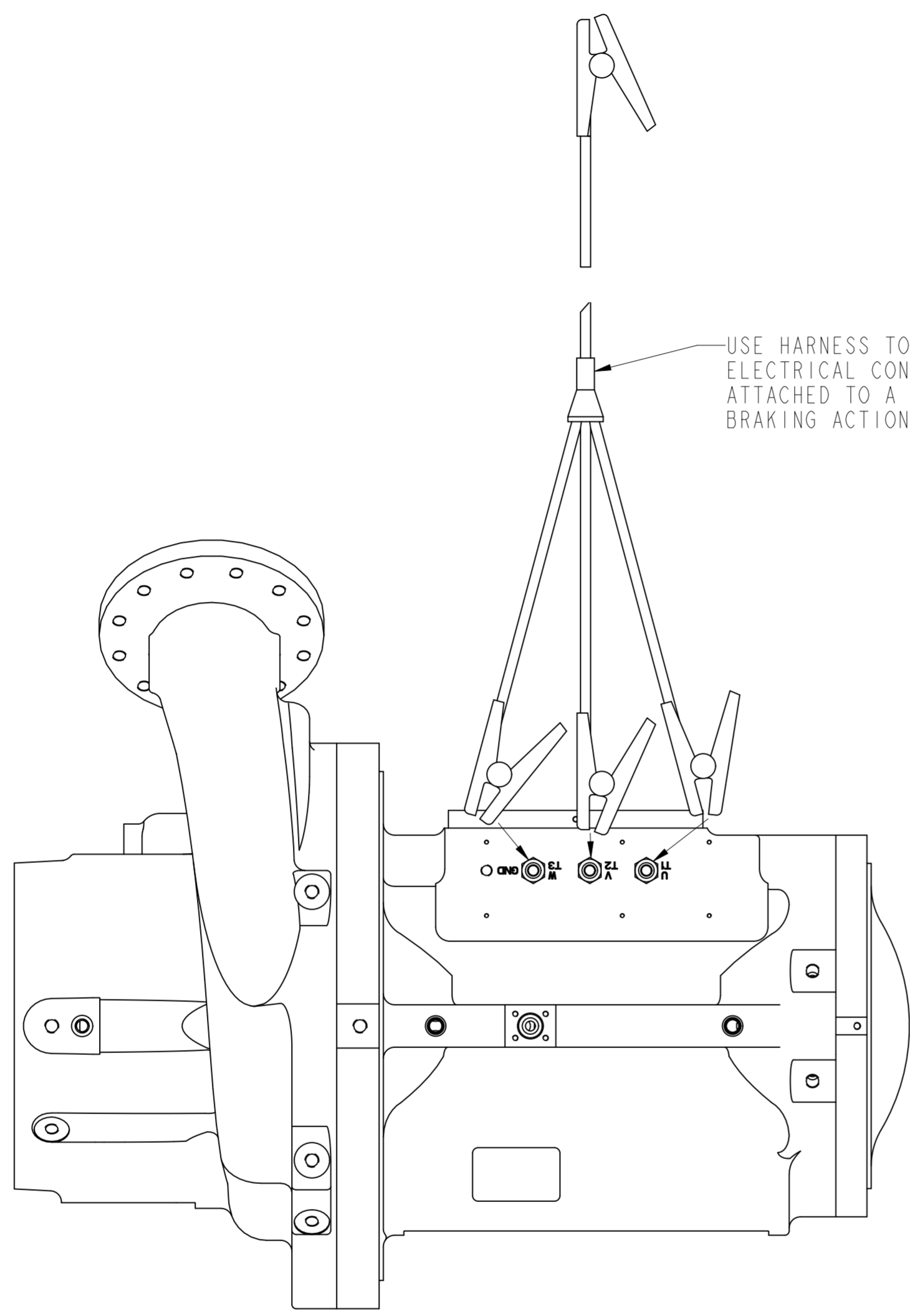

USE HARNESS TO SHORT AND GROUND TERMINALS WHEN SERVICING ELECTRICAL CONNECTIONS OR DRIVE, WHILE COMPRESSOR IS ATTACHED TO A CHARGED CHILLER. SHORTING WILL APPLY BRAKING ACTION AND ELIMINATE STRAY VOLTAGE.

				JOHNSON CONTROLS - BUILDING EFFICIENCY 507 EAST MICHIGAN STREET, MILWAUKEE, WI, 53202 USA			
DO NOT SCALE		HARNES GROUNDING		MATERIAL			
DRAWN D. T. KYDE 16-NOV-2011		CAGE NUMBER		DRAWING NUMBER		REVISION	
MODELER D. T. KYDE 16-NOV-2011		A2 66935		325-44935-000		A	
CHKD D. T. KYDE 16-NOV-2011		ENG		ORIG. NO.:		VERSION	
SCALE: 1:25		MASS (kg): 9.692		SHEET 2 OF 2		RELEASED	

REV.	DATE	EC. NO.	DR.	CHK.	ENG.
A	08-MAY-2013	0913-3010	DTK	DTK	SJE
SHEET 1: ADDED NOTE 2.					
SHEET 2: ADDED THIS SHEET.					

ALL PROPRIETARY RIGHTS IN THE SUBJECT MATTER HEREOF ARE RESERVED AND NO PERMISSION IS GRANTED TO REPRODUCE THIS PRINT IN WHOLE OR IN ANY PART, OR DISCLOSE ANY OF THE INFORMATION UPON IT TO OTHERS WITHOUT WRITTEN RELEASE BY JOHNSON CONTROLS INCORPORATED

12 11 10 9 8 7 6 5 4 3 2 1