

Colorflow[®] and Ball Valves

Industrial Flow Control, Check, Gauge Control

Catalog HY14-3300/US

aerospace
climate control
electromechanical
filtration
fluid & gas handling
hydraulics
pneumatics
process control
sealing & shielding



ENGINEERING YOUR SUCCESS.

Fully guided poppets are used on Colorflow valves rather than the less durable ball-check type construction. Poppets open and close more smoothly — last longer — and eliminate the distortion of seats and springs.

The exclusive “Colorflow” feature on metering, flow control, and needle valves gives highly visible check-points for setting valve openings. This feature also provides a reference point that allows the valve to be accurately and quickly reset to a previous setting.

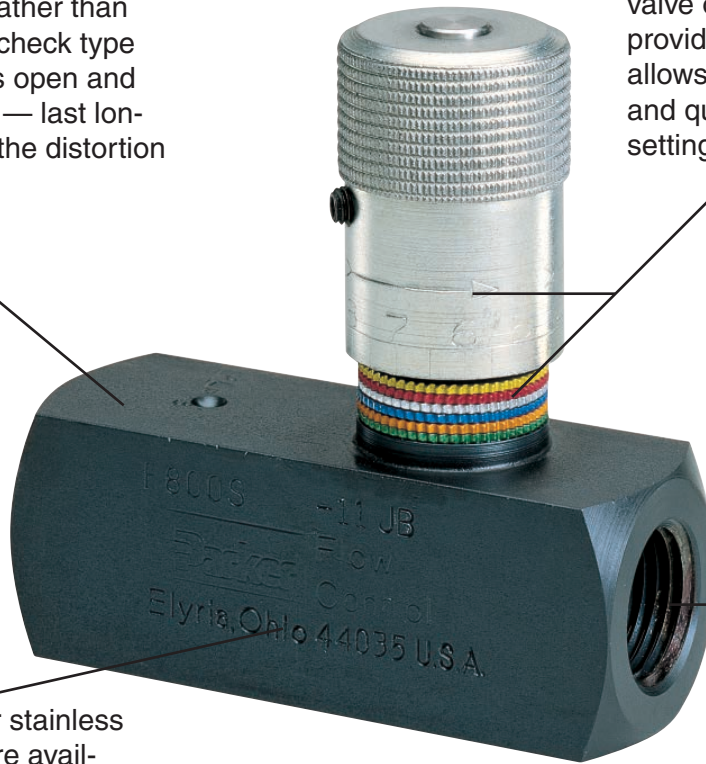

Steel, brass or stainless steel bodies are available, all of which include stainless steel needles as standard.

Colorflow valves are available with a variety of porting options.

WARNING: Colorflow valves are not repairable

⚠ WARNING – USER RESPONSIBILITY

FAILURE OR IMPROPER SELECTION OR IMPROPER USE OF THE PRODUCTS DESCRIBED HEREIN OR RELATED ITEMS CAN CAUSE DEATH, PERSONAL INJURY AND PROPERTY DAMAGE.

- This document and other information from Parker-Hannifin Corporation, its subsidiaries and authorized distributors provide product or system options for further investigation by users having technical expertise.
- The user, through its own analysis and testing, is solely responsible for making the final selection of the system and components and assuring that all performance, endurance, maintenance, safety and warning requirements of the application are met. The user must analyze all aspects of the application, follow applicable industry standards, and follow the information concerning the product in the current product catalog and in any other materials provided from Parker or its subsidiaries or authorized distributors.
- To the extent that Parker or its subsidiaries or authorized distributors provide component or system options based upon data or specifications provided by the user, the user is responsible for determining that such data and specifications are suitable and sufficient for all applications and reasonably foreseeable uses of the components or systems.

OFFER OF SALE

The items described in this document are hereby offered for sale by Parker-Hannifin Corporation, its subsidiaries or its authorized distributors. This offer and its acceptance are governed by the provisions stated in the detailed “Offer of Sale” elsewhere in this document or available at www.parker.com/hydraulicvalve.

SAFETY GUIDE

For safety information, see Safety Guide SG HY14-1000 at www.parker.com/safety or call 1-800-CParker.

© Copyright 2012 Parker Hannifin Corporation, All Rights Reserved

Contents

Colorflow® Valves

Page

Flow Control Valves

Series F Flow Controls 4 - 7

Series 6F Flow Controls (Metric Ports) 8 - 9

Series PC*K Pressure Compensated Flow Controls 10 - 12

Series PC*M Pressure Compensated Flow Controls, Adjustable 13 - 15

Series N Needle Valves 16 - 18

Series 6N Needle Valves (Metric Ports) 19 - 20

Series MV Metering Valves 21 - 24

Series MVI Cartridge-type Metering 25 - 27

Check Valves

Series C Check Valves 28 - 30

Series 6C Check Valves (Metric Ports) 31 - 32

Series VCL Check Valves 33 - 36

Gauge Control Valves

Series GF Gauge Isolator Valve 37

Series GT Push-to-Read Gauge Isolator Valve 38

Ball Valves

High Pressure Ball Valves

Series BVHP 2-Way, 414 Bar (6000 PSI) 1/4"-1", in-line 40 - 55

Series BVAH 2-Way, 414 Bar (6000 PSI) 1 1/4"-2", in-line 40 - 55

Series BVHS 2-Way, 414 Bar (6000 PSI) 1/4"-1", in-line 40 - 55

Series BVHH 2-Way, 690 Bar (10,000 PSI) 1/2"-2", in-line 56 - 59

Series BVAM 2-Way, 138 Bar (2000 PSI) 1/2"-4", in-line 60 - 63

Series BV3D 3-Way, 207 Bar (3000 PSI) 1/4"-2", in-line 64 - 68

Series BV3H 3-Way, 414 Bar (6000 PSI) 1/4"-2", in-line 69 - 72

Series BV4H 4-Way, 414 Bar (6000 PSI) 1/4"-2", in-line 69 - 72

Series BVMM 2 and 3-Way, 414 Bar (6000 PSI) 1/4"-2", manifold 73 - 78

Series BVAL 2-Way, 28 Bar (400 PSI) 1/4"-4", aluminum-suction 79 - 82

Technical Appendix 83 - 84

Low Pressure Ball Valves

Series 500 2-Way, 41 Bar (600 PSI) 1/4"-2", brass 85 - 95

Series 520 2-Way, 41 Bar (600 PSI) 1/4" - 3" brass 96 - 97

Series 500CS 2-Way, 138 Bar (2000 PSI) 1/4"-1", steel 98 - 101

Series 50*SS 2-Way, 138 Bar (2000 PSI) 1/4"-1", stainless steel 102 - 105

Series 590 2-Way, 17 Bar (250 PSI) 1/4"-1/2", brass-right angle 106 - 108

Terms of Sale with Warranty Limitations 109

Safety Guide 110 - 111

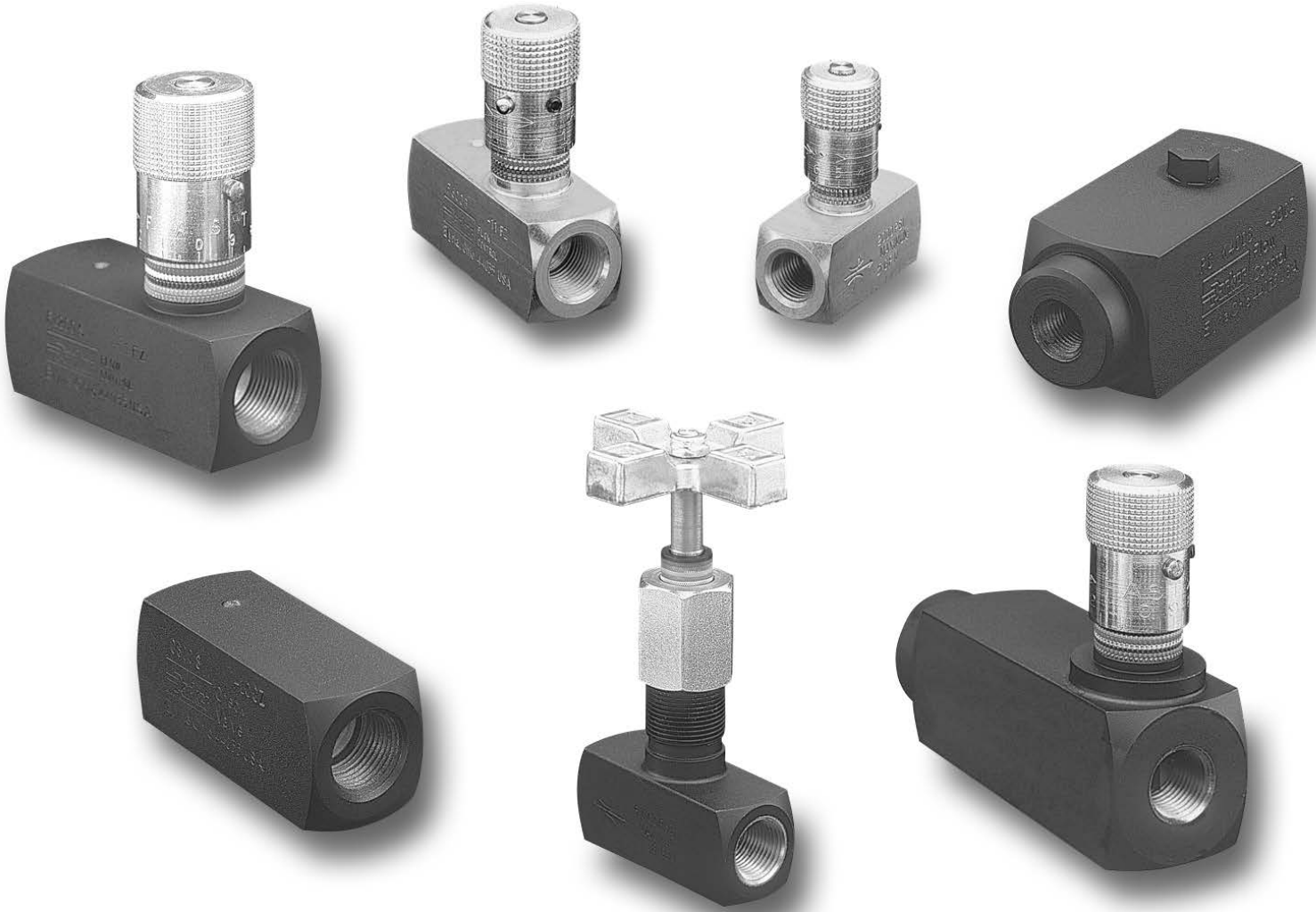

Flow Control Valves
Check Valves
Gauge Control Valves

Colorflow[®] Valves



ENGINEERING YOUR SUCCESS.

General Description

Series F flow control valves provide precise control of flow and shut-off in one direction, and automatically permit full flow in the opposite direction.

Operation

A two-step needle allows fine adjustment at low flow by using the first three turns of the adjusting knob. The next three turns open the valve to full flow, and also provide standard throttling adjustments.

Features

- The exclusive “Colorflow” color-band reference scale on the valve stem is a great convenience and time-saver in setting the valve originally and in returning it to any previous setting.
- A simple set screw locks the valve on any desired setting.
- A tamperproof option (T) feature is also available to prevent accidental or intentional adjustment of flow setting.

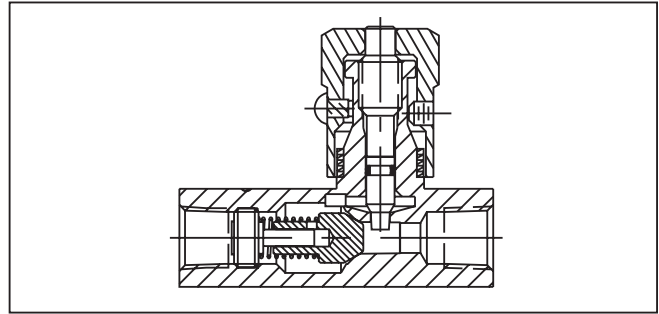
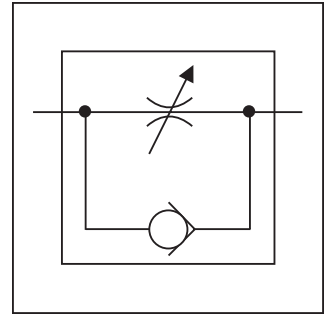

Specifications

Maximum Operating Pressure	Brass:	140 Bar (2000 PSI); except for F1600 brass which is 35 Bar (500 PSI)	Poppets	Soft seal poppet in brass 200 - 820 sizes
	Steel & Stainless Steel:	345 Bar (5000 PSI) for 200 thru 1020; 207 Bar (3000 PSI) for all other sizes		Solid metal 416 stainless steel poppet on all other sizes and styles
Material	Body	See ordering code	Nominal Cracking Pressure	0.4 Bar (5 PSI) standard
	Knob	Steel - Zinc plated	Temperature Range of Seal Compound	-40°C to +121°C (-40°F to +250°F) Nitrile (standard)
	Spring	316 Stainless Steel		-26°C to +205°C (-15°F to +400°F) Fluorocarbon
Needle	416 Stainless Steel			
Poppet	416 Stainless Steel			
Retainer	416 Stainless Steel			
Stainless Steel	303 Stainless Steel			
Bodies				

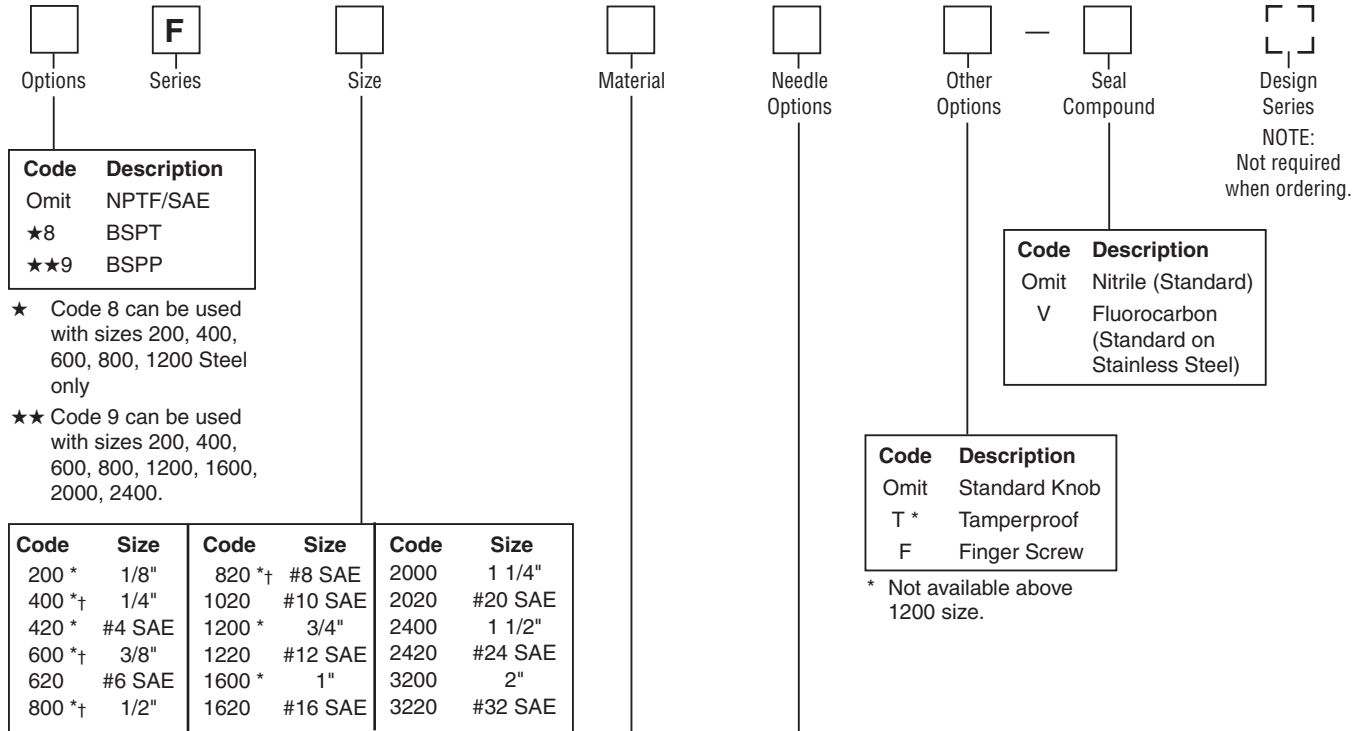

* Sizes available in Brass.

† Sizes available in Stainless Steel.

Model Number	Free Flow Rate, Max. LPM (GPM)	Free Flow Orifice Area in. ²	Free Flow C _v	Effective Orifice Area, Control Flow in. ²	Effective Control Flow C _v
F200	11 (3)	0.023	0.53	0.0102	0.230
F420	11 (3)	0.023	0.53	0.0102	0.230
F400	19 (5)	0.068	1.56	0.0194	0.433
F620	19 (5)	0.068	1.56	0.0194	0.433
F600	30 (8)	0.099	2.27	0.0344	0.787
F820	30 (8)	0.099	2.27	0.0344	0.787
F800	57 (15)	0.224	5.11	0.0427	0.976
F1020	57 (15)	0.224	5.11	0.0427	0.976
F1200	95 (25)	0.348	7.95	0.1080	2.470
F1220	95 (25)	0.348	7.95	0.1080	2.470
F1600	151 (40)	0.453	10.35	0.2300	5.250
F1620	151 (40)	0.453	10.35	0.3070	7.000
F2000	265 (70)	0.855	19.52	0.2300	5.250
F2020	265 (70)	0.855	19.52	0.3710	8.470
F2400	379 (100)	0.955	21.82	0.2300	5.250
F2420	379 (100)	0.955	21.82	0.3710	8.470
F3200	568 (150)	1.046	23.90	0.2300	5.250
F3220	568 (150)	1.046	23.90	0.6010	13.410

Model Number	Effective Orifice Area Control Flow in. ²	Effective Control Flow C _v
F400-4	0.0044	0.0758
F600-4	0.0097	0.153
F620-4	0.0044	0.0758
F820-4	0.0097	0.153

Controlled Flow vs. Pressure Drop
 Needle Full Open

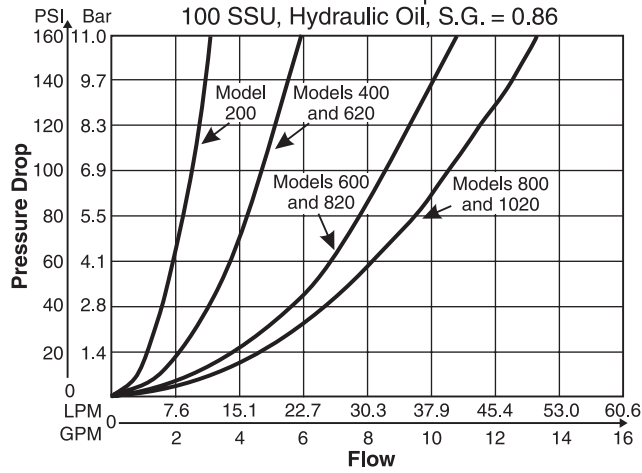

Controlled Flow vs. Pressure Drop
 Needle Full Open

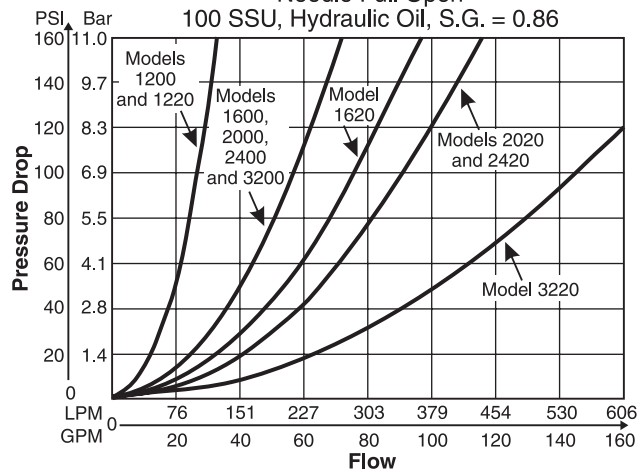

Inch equivalents for millimeter dimensions are shown in (**)

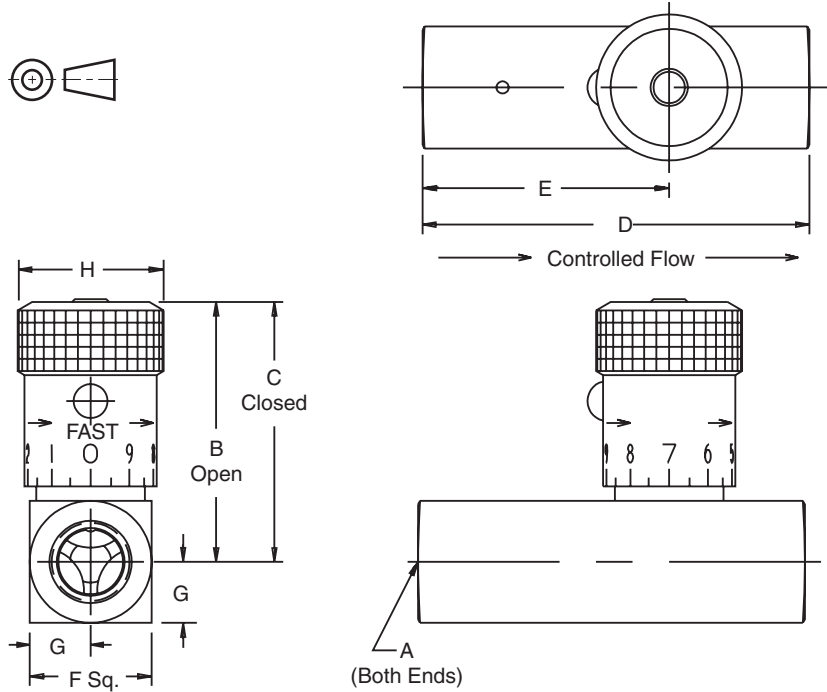

Knob Options

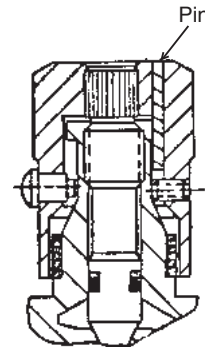

Tamperproof Option (Code "T") permanently locks knob at desired flow setting by installing a pin in predrilled hole.

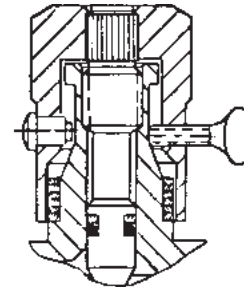

Finger screw Option (Code "F") provides this thumb-screw in place of set screw.

Model Number	Weight kg (lbs)	A	B	C	D	E	F	G	H
F200	0.1 (0.3)	1/8-27 NPTF	39.1 (1.54)	35.3 (1.39)	50.8 (2.00)	32.5 (1.28)	16.0 (0.63)	7.9 (0.31)	19.1 (0.75)
F400	0.2 (0.5)	1/4-18 NPTF	45.5 (1.79)	40.4 (1.59)	66.8 (2.63)	42.2 (1.66)	20.6 (0.81)	10.4 (0.41)	20.6 (0.81)
F420	0.2 (0.5)	7/16-20 UNF #4 SAE	41.4 (1.63)	37.6 (1.48)	68.3 (2.69)	42.9 (1.69)	20.6 (0.81)	10.4 (0.41)	19.1 (0.75)
F600	0.3 (0.7)	3/8-18 NPTF	55.4 (2.18)	49.5 (1.95)	69.9 (2.75)	44.5 (1.75)	25.4 (1.00)	12.7 (0.50)	25.4 (1.00)
F620	0.3 (0.7)	9/16-18 UNF #6 SAE	47.7 (1.88)	42.7 (1.68)	79.2 (3.12)	48.8 (1.92)	25.4 (1.00)	12.7 (0.50)	20.6 (0.81)
F800	0.7 (1.5)	1/2-14 NPTF	68.6 (2.70)	61.5 (2.42)	87.4 (3.44)	56.6 (2.23)	31.8 (1.25)	16.0 (0.63)	30.2 (1.19)
F820	0.5 (1.1)	3/4-16 UNF #8 SAE	56.9 (2.24)	51.1 (2.01)	88.9 (3.50)	53.8 (2.12)	28.4 (1.12)	14.2 (0.56)	25.4 (1.00)
F1020	0.8 (1.8)	7/8-14 UNF #10 SAE	68.6 (2.70)	61.5 (2.42)	101.6 (4.00)	65.0 (2.56)	31.8 (1.25)	15.7 (0.62)	30.2 (1.19)
F1200	1.2 (2.6)	3/4-14 NPTF	85.9 (3.38)	71.4 (2.81)	98.6 (3.88)	65.5 (2.58)	38.1 (1.50)	19.1 (0.75)	35.1 (1.38)
F1220	1.2 (2.6)	1 1/16-12 UN #12 SAE	85.9 (3.38)	71.4 (2.81)	117.3 (4.62)	76.5 (3.01)	38.1 (1.50)	19.1 (0.75)	35.1 (1.38)
F1600	2.3 (5.1)	1-11 1/2 NPTF	123.7 (4.87)	106.9 (4.21)	127.0 (5.00)	81.8 (3.22)	44.5 (1.75)	22.4 (0.88)	47.8 (1.88) *
F1620	2.3 (5.1)	1 5/16-12 UN #16 SAE	130.8 (5.15)	114.0 (4.49)	142.7 (5.62)	88.9 (3.50)	57.2 (2.25)	28.4 (1.12)	47.8 (1.88) *
F2000	3.7 (8.2)	1 1/4-11 1/2 NPTF	130.0 (5.12)	113.3 (4.46)	143.0 (5.63)	98.6 (3.88)	57.2 (2.25)	28.7 (1.13)	47.8 (1.88) *
F2020	3.7 (8.2)	1 5/8-12 UN #20 SAE	140.2 (5.52)	123.4 (4.86)	165.1 (6.50)	108.0 (4.25)	69.9 (2.75)	35.1 (1.38)	47.8 (1.88) *
F2400	4.6 (10.2)	1 1/2-11 1/2 NPTF	136.4 (5.37)	119.6 (4.71)	143.0 (5.63)	113.5 (4.47)	69.9 (2.75)	35.1 (1.38)	47.8 (1.88) *
F2420	4.6 (10.2)	1 7/8-12 UN-2B #24 SAE	143.5 (5.65)	126.7 (4.99)	184.2 (7.25)	127.0 (5.00)	76.2 (3.00)	38.1 (1.50)	47.8 (1.88) *
F3200	7.9 (17.4)	2-11 1/2 NPTF	146.1 (5.75)	129.3 (5.09)	165.1 (6.50)	134.9 (5.31)	88.9 (3.50)	44.5 (1.75)	47.8 (1.88) *
F3220	7.9 (17.4)	2 1/2-12 UN #32 SAE	163.6 (6.44)	139.4 (5.49)	228.6 (9.00)	155.7 (6.13)	101.6 (4.00)	50.8 (2.00)	47.8 (1.88) *

* = Hex

General Description

Series 6F flow control valves provide precise control of flow and shut-off in one direction, and automatically permit full flow in the opposite direction.

Operation

A two-step needle allows fine adjustment at low flow by using the first three turns of the adjusting knob. The next three turns open the valve to full flow, and also provide standard throttling adjustments.

Features

- Meets ISO 6149 standards.
- Hard metric dimensions.
- Reliable leak-free performance — straight thread port with o-ring sealing.
- Global interchangeability.

Specifications

Maximum Operating Pressure	M16 x 1.5	345 Bar	(5000 PSI)
	M18 x 1.5	345 Bar	(5000 PSI)
	M22 x 1.5	345 Bar	(5000 PSI)
	M27 x 2.0	207 Bar	(3000 PSI)
	M33 x 2.0	207 Bar	(3000 PSI)
Maximum Flow	M16 x 1.5	19 LPM	(5 GPM)
	M18 x 1.5	30 LPM	(8 GPM)
	M22 x 1.5	57 LPM	(15 GPM)
	M27 x 2.0	95 LPM	(25 GPM)
	M33 x 2.0	151 LPM	(40 GPM)
Material	Body	ASTM 12L14	Carbon Steel
	Knob	ASTM 12L14	Carbon Steel
	Needle	ASTM 416	Stainless Steel
	Poppet	ASTM 416	Stainless Steel
	Retainer	ASTM 416	Stainless Steel
	Spring	ASTM 316	Stainless Steel
Temperature Range of Seal Compound	-40°C to +121°C (-40°F to +250°F) Nitrile (Standard)		
	-26°C to +205°C (-15°F to +400°F) Fluorocarbon		

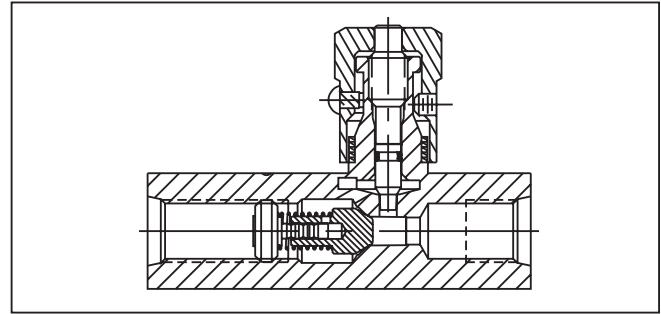
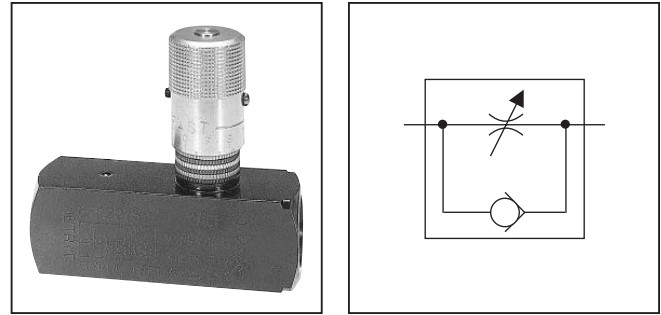

Performance Curves

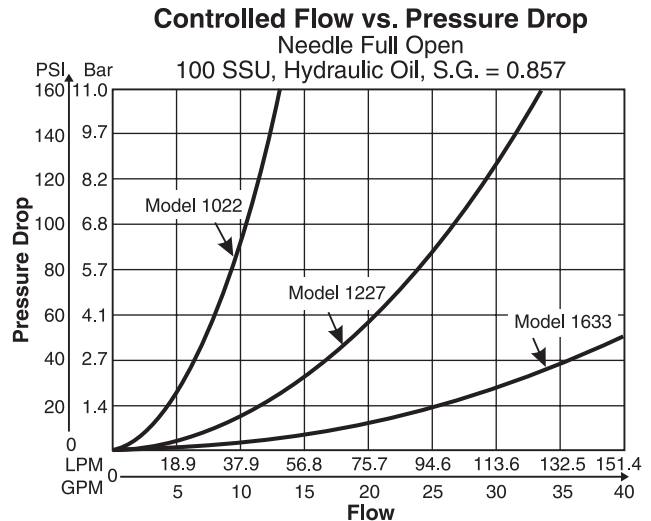
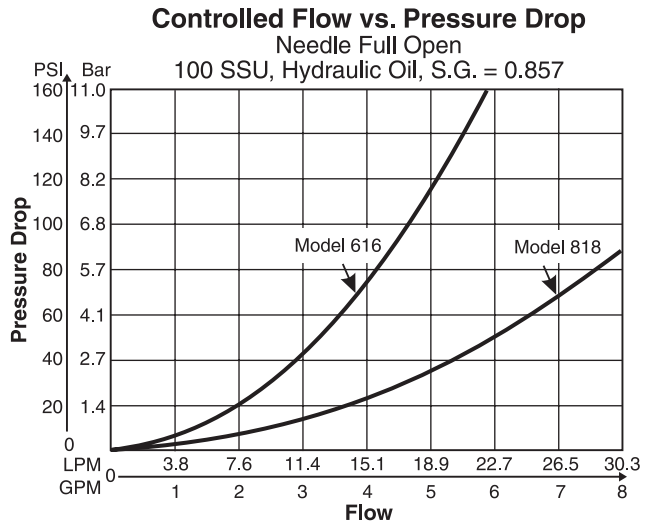

Ordering Information

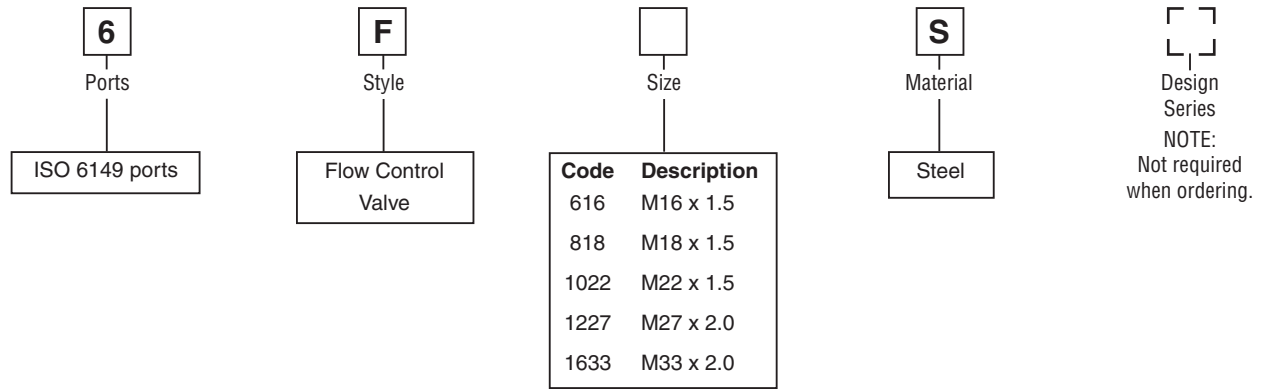

Dimensions

Inch equivalents for millimeter dimensions are shown in (**)

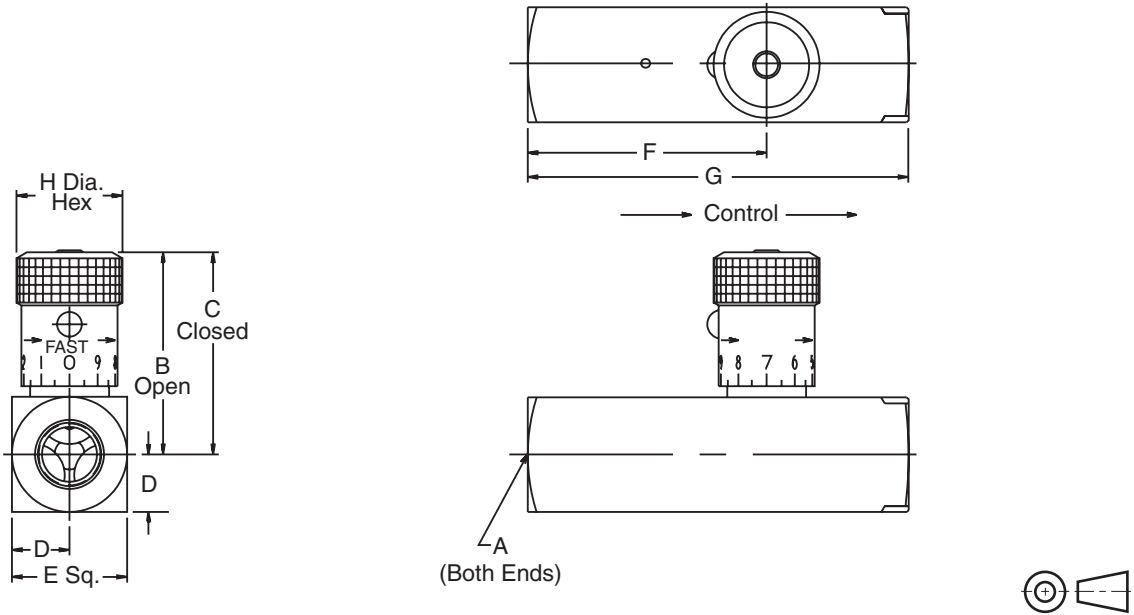

Model Number	Weight kg (lbs.)	A	B	C	D	E	F	G	H
6F616	0.3 (0.7)	M16 x 1.5	47.8 (1.88)	42.7 (1.68)	12.7 (0.50)	25.4 (1.00)	48.7 (1.92)	79.2 (3.12)	20.6 (Ø 0.81)
6F818	0.5 (1.1)	M18 x 1.5	56.9 (2.24)	51.1 (2.01)	14.2 (0.56)	28.4 (1.12)	53.8 (2.12)	88.9 (3.50)	25.4 (Ø 1.00)
6F1022	0.8 (1.8)	M22 x 1.5	68.6 (2.70)	61.5 (2.42)	15.7 (0.62)	31.8 (1.25)	65.0 (2.56)	101.6 (4.00)	30.2 (Ø 1.19)
6F1227	1.2 (2.6)	M27 x 2.0	85.9 (3.38)	71.4 (2.81)	19.1 (0.75)	38.1 (1.50)	76.5 (3.01)	117.3 (4.62)	35.1 (Ø 1.38)
6F1633	2.3 (5.1)	M33 x 2.0	124.7 (4.91)	108.0 (4.25)	22.4 (0.88)	44.5 (1.75)	81.8 (3.22)	127.0 (5.00)	47.8 (*1.88)

* = Hex

General Description

Series PCK pressure compensated flow control valves are designed to regulate flow at a selected rate, within 5%, regardless of fluctuations in inlet and outlet pressure.

Operation

Series PCK valves are factory-set for a specified flow. The flow can be changed with a different "PCK" Orifice Plug Kit (sold separately).

Features

- Available with reverse flow check.
- Flow precision within $\pm 5\%$ of full flow.

Specifications

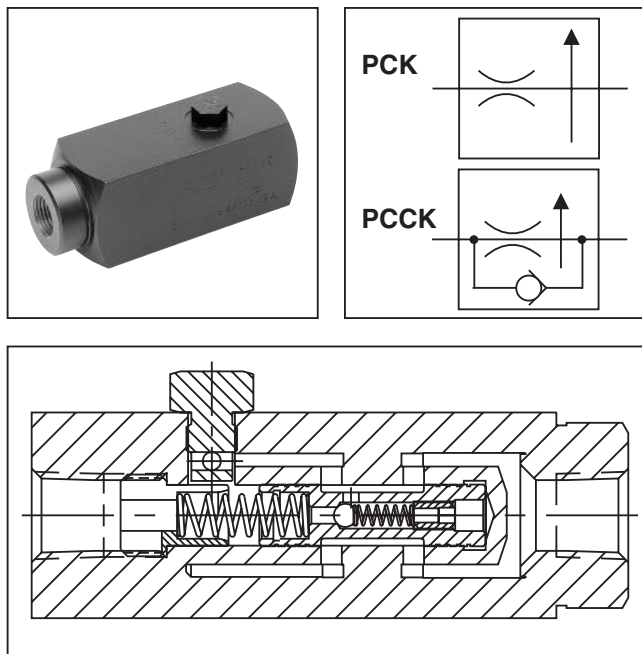

	PC*K400S PC*K620S	PC*K600S PC*K820S	PC*K800S PC*K1020S	PC*K1200S PC*K1220S
Maximum Operating Pressure	207 Bar (3000 PSI)			
Minimum Pressure to Compensate	6.9 Bar (100 PSI)	6.9 Bar (100 PSI)	6.9 Bar (100 PSI)	10.4 Bar (150 PSI)
Temperature Range of Seal Compound	-40°C to +121°C (-40°F to +250°F) Nitrile (standard) -26°C to +205°C (-15°F to +400°F) Fluorocarbon			
Mounting	In-line			
Maximum Flow	11 LPM (3 GPM)	23 LPM (6 GPM)	57 LPM (15 GPM)	95 LPM (25 GPM)
Minimum Flow	1 LPM (0.3 GPM)	2 LPM (0.6 GPM)	6 LPM (1.5 GPM)	10 LPM (2.5 GPM)
Reverse Flow, Maximum thru Check	19 LPM (5 GPM)	30 LPM (8 GPM)	76 LPM (20 GPM)	132 LPM (35 GPM)
Pressure Drop, ΔP at Maximum Reverse Flow thru Check	3 Bar (40 PSI)	3 Bar (40 PSI)	PC*K800S: 8 Bar (116 PSI) PC*K1020S: 3 Bar (40 PSI)	PC*K1200S: 8 Bar (116 PSI) PC*K1220S: 3 Bar (40 PSI)
Port Size (in.)	PC*K400S: 1/4 NPTF PC*K620S: 9/16-18 UNF (SAE 6)	PC*K600S: 3/8 NPTF PC*K820S: 3/4-16 UNF (SAE 8)	PC*K800S: 1/2 NPTF PC*K1020S: 7/8-14 UNF (SAE 10)	PC*K1200S: 3/4 NPTF PC*K1220S: 1-1/16-12 UN (SAE 12)

* For optional reverse-flow check, insert "C" in model number at asterisk (*).

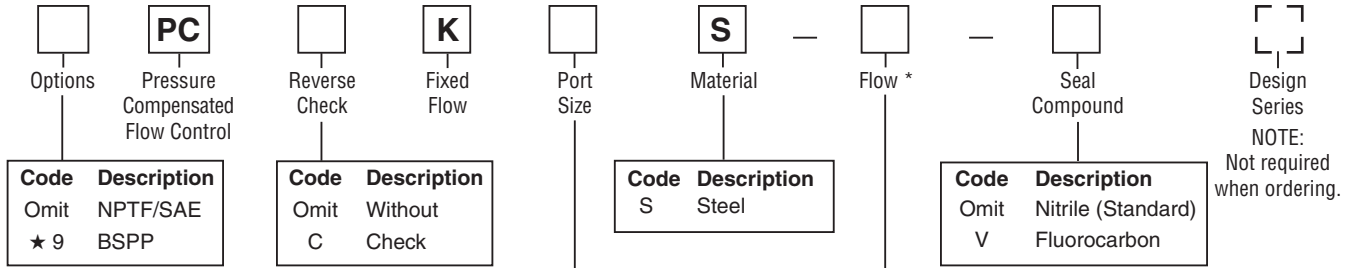

★ Code 9 can be used with sizes 400, 600, 800 and 1200

Code	Size
400	1/4"
600	3/8"
620	#6 SAE
800	1/2"
820	#8 SAE
1020	#10 SAE
1200	3/4"
1220	#12 SAE

Available Flow Settings GPM (LPM)							
PCK 400/620 GPM (LPM)	PCK 600/820 GPM (LPM)	PCK 800/1020 GPM (LPM)	PCK 1200/1220 GPM (LPM)				
0.25 (0.9)	0.50 (1.9)	2.00 (7.57)	4.00 (15.14)				
0.50 (1.9)	1.00 (3.8)	3.00 (11.36)	6.00 (22.71)				
0.75 (2.8)	1.50 (5.7)	4.00 (15.14)	8.00 (30.28)				
1.00 (3.8)	2.00 (7.6)	5.00 (18.93)	10.00 (37.85)				
1.25 (4.7)	2.50 (9.5)	6.00 (22.71)	12.00 (45.42)				
1.50 (5.7)	3.00 (11.4)	7.00 (26.50)	14.00 (52.99)				
1.75 (6.6)	3.50 (13.2)	8.00 (30.28)	16.00 (60.56)				
2.00 (7.6)	4.00 (15.1)	9.00 (34.07)	18.00 (68.13)				
2.25 (8.5)	4.50 (17.0)	10.00 (37.85)	20.00 (75.70)				
2.50 (9.5)	5.00 (18.9)	11.00 (41.64)	22.00 (83.27)				
2.75 (10.4)	5.50 (20.8)	12.00 (45.42)	24.00 (90.84)				
3.00 (11.4)	6.00 (22.7)	13.00 (49.21)					
		14.00 (52.99)					
		15.00 (56.78)					

Note: Settings are based on using 100 SSU at +49°C (+120°F).

* To order this valve you must indicate appropriate GPM value from table. Example: 9PCCK600S-3.50-V

“PK” Orifice Plug Kits

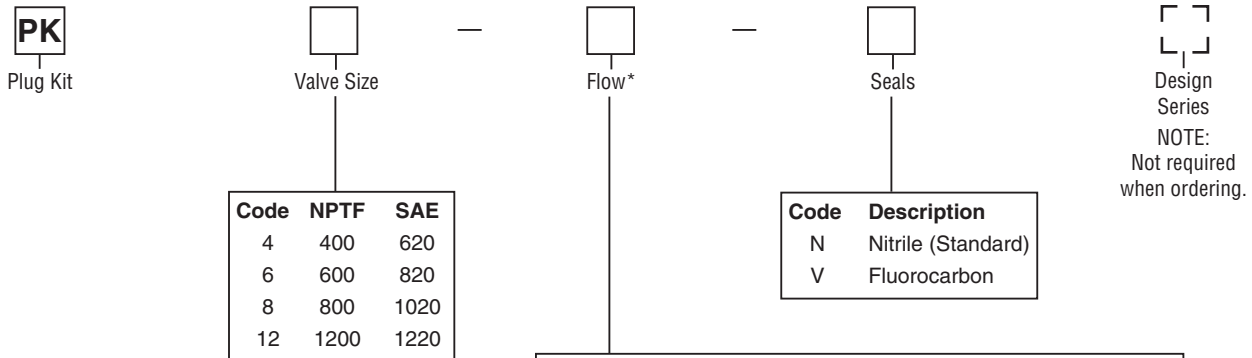

Model Number	Weight kg (lbs.)
PK4-*N	0.5 (0.1)
PK6-*N	0.5 (0.1)
PK8-*N	0.5 (0.1)
PK12-*N	0.5 (0.1)

Available Flow Settings GPM (LPM)							
PCK 400/620 GPM (LPM)	PCK 600/820 GPM (LPM)	PCK 800/1020 GPM (LPM)	PCK 1200/1220 GPM (LPM)				
0.25 (0.9)	0.50 (1.9)	2.00 (7.57)	4.00 (15.14)				
0.50 (1.9)	1.00 (3.8)	3.00 (11.36)	6.00 (22.71)				
0.75 (2.8)	1.50 (5.7)	4.00 (15.14)	8.00 (30.28)				
1.00 (3.8)	2.00 (7.6)	5.00 (18.93)	10.00 (37.85)				
1.25 (4.7)	2.50 (9.5)	6.00 (22.71)	12.00 (45.42)				
1.50 (5.7)	3.00 (11.4)	7.00 (26.50)	14.00 (52.99)				
1.75 (6.6)	3.50 (13.2)	8.00 (30.28)	16.00 (60.56)				
2.00 (7.6)	4.00 (15.1)	9.00 (34.07)	18.00 (68.13)				
2.25 (8.5)	4.50 (17.0)	10.00 (37.85)	20.00 (75.70)				
2.50 (9.5)	5.00 (18.9)	11.00 (41.64)	22.00 (83.27)				
2.75 (10.4)	5.50 (20.8)	12.00 (45.42)	24.00 (90.84)				
3.00 (11.4)	6.00 (22.7)	13.00 (49.21)					
		14.00 (52.99)					
		15.00 (56.78)					

Note: Settings are based on using 100 SSU at +120°F (+49°C).

* To order this plug kit you must indicate appropriate GPM value from table. Example: PK6-3.50-N

Performance Curves

**PC*K Series
 Controlled Flow vs. Pressure Drop
 at Maximum Flow Setting
 Typical for All Sizes**

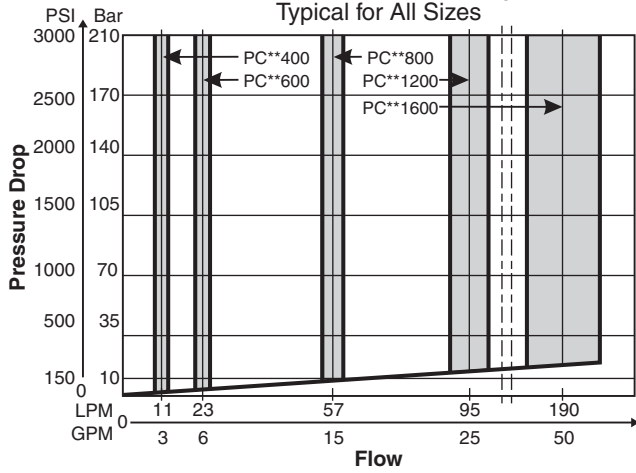

Dimensions

Inch equivalents for millimeter dimensions are shown in (**)

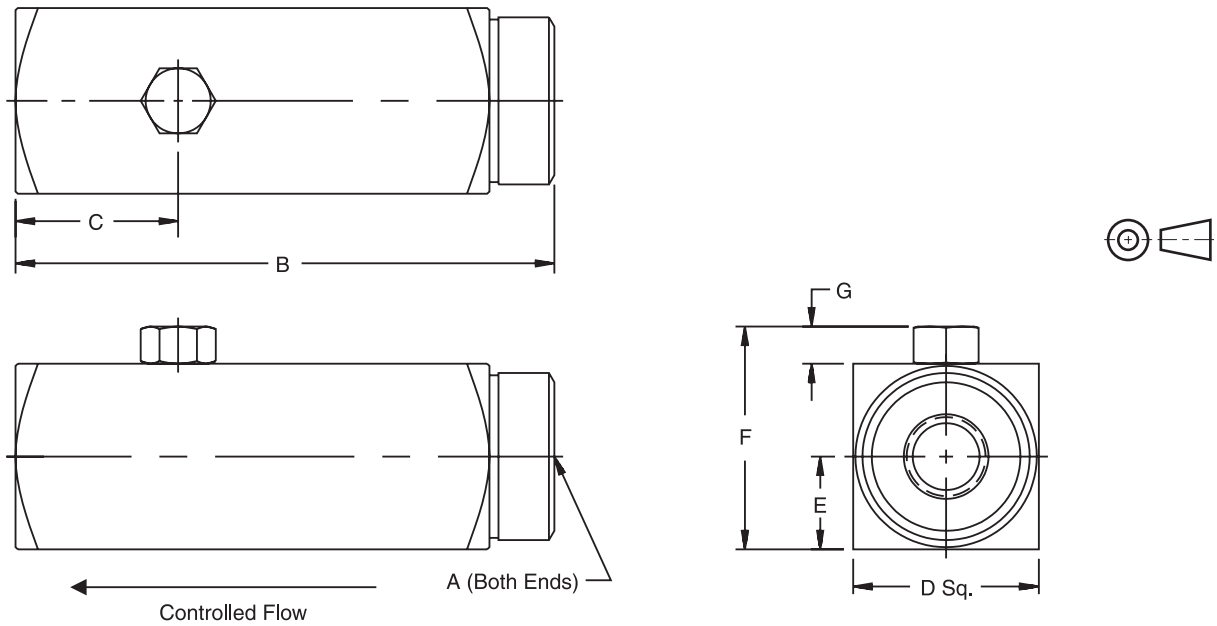

Model Number	Weight kg (lbs.)	A	B	C	D	E	F	G
PC*K400/620	0.03 (0.7)	1/4-18 NPTF/9/16-18 UNF	92.2 (3.63)	27.7 (1.09)	31.8 (1.25)	17.5 (0.69)	38.1 (1.50)	6.4 (0.25)
PC*K600	1.00 (2.1)	3/8-18 NPTF	105.7 (4.16)	30.2 (1.19)	38.1 (1.50)	19.1 (0.75)	44.5 (1.75)	6.4 (0.25)
PC*K 820	1.00 (2.1)	3/4-16 UNF	112.5 (4.43)	37.3 (1.47)	38.1 (1.50)	19.1 (0.75)	44.5 (1.75)	6.4 (0.25)
PC*K800/1020	1.50 (3.3)	1/2-14 NPTF/7/8-14 UNF	125.5 (4.94)	36.6 (1.44)	44.5 (1.75)	22.4 (0.88)	50.8 (2.00)	6.4 (0.25)
PC*K1200/1220	1.50 (3.3)	3/4-14 NPTF/1 1/16-12 UNF	149.4 (5.88)	27.7 (1.09)	57.2 (2.25)	28.7 (1.13)	63.5 (2.50)	6.4 (0.25)

3300-colorflow.indd, ddp

General Description

Series PCM pressure compensated flow control valves are designed to regulate flow at a selected rate, within 5%, regardless of fluctuations in inlet and outlet pressure.

Operation

Series PCM valves can be adjusted for required flows after being installed.

Features

- Available with reverse flow check.
- The exclusive “Colorflow” color-band reference scale on the valve stem is a great convenience and time-saver in setting the valve originally and in returning it to any previous setting.
- A simple set screw locks the valve on any desired setting.
- A tamperproof option (T) feature is also available to prevent accidental or intentional adjustment of flow setting.

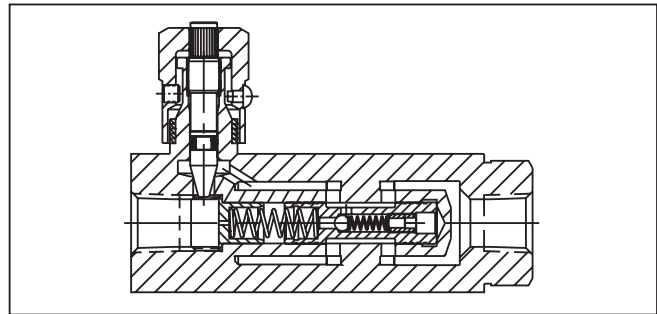
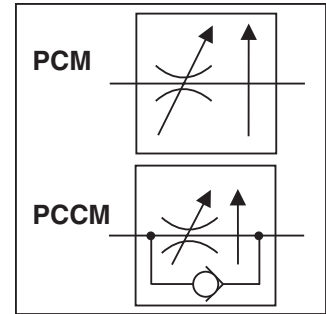

Specifications

	PC*M400S PC*M620S	PC*M600S PC*M820S	PC*M800S PC*M1020S	PC*M1200S PC*M1220S	PC*M1600S PC*M1620S	PC*M2000S
Maximum Operating Pressure	207 Bar (3000 PSI)					
Minimum Pressure to Compensate	6.9 Bar (100 PSI)	6.9 Bar (100 PSI)	6.9 Bar (100 PSI)	10.4 Bar (150 PSI)	10.4 Bar (150 PSI)	10.4 Bar (150 PSI)
Temperature Range of Seal Compound	-40°C to +121°C (-40°F to +250°F) Nitrile (standard) -26°C to +205°C (-15°F to +400°F) Fluorocarbon					
Mounting	Inline					
Maximum Flow	11 LPM (3 GPM)	23 LPM (6 GPM)	57 LPM (15 GPM)	95 LPM (25 GPM)	189 LPM (50 GPM)	303 LPM (80 GPM)
Minimum Flow	1 LPM (0.3 GPM)	2 LPM (0.6 GPM)	6 LPM (1.5 GPM)	10 LPM (2.5 GPM)	19 LPM (5.0 GPM)	30 LPM (8 GPM)
Reverse Flow, Maximum thru Check	19 LPM (5 GPM)	30 LPM (8 GPM)	76 LPM (20 GPM)	132 LPM (35 GPM)	227 LPM (60 GPM)	378 LPM (100 GPM)
Pressure Drop, ΔP at Maximum Reverse Flow thru Check	3 Bar (40 PSI)	3 Bar (40 PSI)	PC*M800S: 8 Bar (116 PSI) PC*M1020S: 3 Bar (40 PSI)	PC*M1200S: 8 Bar (116 PSI) PC*M1220S: 3 Bar (40 PSI)	10 Bar (140 PSI)	11 Bar (155 PSI)
Port Size (in.)	PC*M400S: 1/4 NPTF PC*M620S: 9/16-18 UNF (SAE 6)	PC*M600S: 3/8 NPTF PC*M820S: 3/4-16 UNF (SAE 8)	PC*M800S: 1/2 NPTF PC*M1020S: 7/8-14 UNF (SAE 10)	PC*M1200S: 3/4 NPTF PC*M1220S: 1-1/16-12 UNF (SAE 12)	PC*M1600S: 1 NPTF PC*M1620: 1-5/16-12 UNF (SAE 16)	PC*M2000S: 1 1/4" NPTF

For optional reverse-flow check, insert “C” in model number at asterisk ().

Ordering Information

<div style="border: 1px solid black; width: 30px; height: 30px; margin: 0 auto;"></div> <p>Options</p>	<div style="border: 1px solid black; width: 30px; height: 30px; margin: 0 auto; display: flex; align-items: center; justify-content: center;"> PC </div> <p>Pressure Compensated Flow Control</p>	<div style="border: 1px solid black; width: 30px; height: 30px; margin: 0 auto;"></div> <p>Reverse Check</p>	<div style="border: 1px solid black; width: 30px; height: 30px; margin: 0 auto; display: flex; align-items: center; justify-content: center;"> M </div> <p>Adjustable Flow</p>	<div style="border: 1px solid black; width: 30px; height: 30px; margin: 0 auto;"></div> <p>Size</p>	<div style="border: 1px solid black; width: 30px; height: 30px; margin: 0 auto;"></div> <p>Material</p>	<div style="border: 1px solid black; width: 30px; height: 30px; margin: 0 auto;"></div> <p>Adjustable Knob Options</p>	<div style="border: 1px solid black; width: 30px; height: 30px; margin: 0 auto;"></div> <p>Seals</p>	<div style="border: 1px dashed black; width: 30px; height: 30px; margin: 0 auto;"></div> <p>Design Series NOTE: Not required when ordering.</p>
--	---	--	--	---	---	--	--	---

<table border="1" style="width: 100%; border-collapse: collapse;"> <thead> <tr> <th style="text-align: left;">Code</th> <th style="text-align: left;">Description</th> </tr> </thead> <tbody> <tr> <td>Omit</td> <td>NPTF/SAE</td> </tr> <tr> <td>★ 9</td> <td>BSPB</td> </tr> </tbody> </table> <p>★ Code 9 can be used with sizes 400, 600, 800, 1200, 1600</p>	Code	Description	Omit	NPTF/SAE	★ 9	BSPB	<table border="1" style="width: 100%; border-collapse: collapse;"> <thead> <tr> <th style="text-align: left;">Code</th> <th style="text-align: left;">Description</th> </tr> </thead> <tbody> <tr> <td>Omit</td> <td>Without</td> </tr> <tr> <td>C</td> <td>Check</td> </tr> </tbody> </table>	Code	Description	Omit	Without	C	Check	<table border="1" style="width: 100%; border-collapse: collapse;"> <thead> <tr> <th style="text-align: left;">Code</th> <th style="text-align: left;">Size</th> </tr> </thead> <tbody> <tr> <td>400</td> <td>1/4"</td> </tr> <tr> <td>600 *</td> <td>3/8"</td> </tr> <tr> <td>620</td> <td>#6 SAE</td> </tr> <tr> <td>800 *</td> <td>1/2"</td> </tr> <tr> <td>820</td> <td>#8 SAE</td> </tr> <tr> <td>1020</td> <td>#10 SAE</td> </tr> <tr> <td>1200</td> <td>3/4"</td> </tr> <tr> <td>1220</td> <td>#12 SAE</td> </tr> <tr> <td>1600</td> <td>1"</td> </tr> <tr> <td>1620</td> <td>#16 SAE</td> </tr> <tr> <td>2000</td> <td>1 1/4"</td> </tr> </tbody> </table> <p>* Available in Stainless Steel</p>	Code	Size	400	1/4"	600 *	3/8"	620	#6 SAE	800 *	1/2"	820	#8 SAE	1020	#10 SAE	1200	3/4"	1220	#12 SAE	1600	1"	1620	#16 SAE	2000	1 1/4"	<table border="1" style="width: 100%; border-collapse: collapse;"> <thead> <tr> <th style="text-align: left;">Code</th> <th style="text-align: left;">Description</th> </tr> </thead> <tbody> <tr> <td>Omit</td> <td>Standard Knob</td> </tr> <tr> <td>T *</td> <td>Tamperproof</td> </tr> <tr> <td>F</td> <td>Finger Screw</td> </tr> </tbody> </table> <p>* Not available above 1200 size.</p>	Code	Description	Omit	Standard Knob	T *	Tamperproof	F	Finger Screw	<table border="1" style="width: 100%; border-collapse: collapse;"> <thead> <tr> <th style="text-align: left;">Code</th> <th style="text-align: left;">Description</th> </tr> </thead> <tbody> <tr> <td>Omit</td> <td>Nitrile (Standard)</td> </tr> <tr> <td>V</td> <td>Fluorocarbon (Standard on Stainless Steel)</td> </tr> </tbody> </table>	Code	Description	Omit	Nitrile (Standard)	V	Fluorocarbon (Standard on Stainless Steel)
Code	Description																																																					
Omit	NPTF/SAE																																																					
★ 9	BSPB																																																					
Code	Description																																																					
Omit	Without																																																					
C	Check																																																					
Code	Size																																																					
400	1/4"																																																					
600 *	3/8"																																																					
620	#6 SAE																																																					
800 *	1/2"																																																					
820	#8 SAE																																																					
1020	#10 SAE																																																					
1200	3/4"																																																					
1220	#12 SAE																																																					
1600	1"																																																					
1620	#16 SAE																																																					
2000	1 1/4"																																																					
Code	Description																																																					
Omit	Standard Knob																																																					
T *	Tamperproof																																																					
F	Finger Screw																																																					
Code	Description																																																					
Omit	Nitrile (Standard)																																																					
V	Fluorocarbon (Standard on Stainless Steel)																																																					

Code	Description
S	Steel
SS	Stainless Steel

Performance Curves

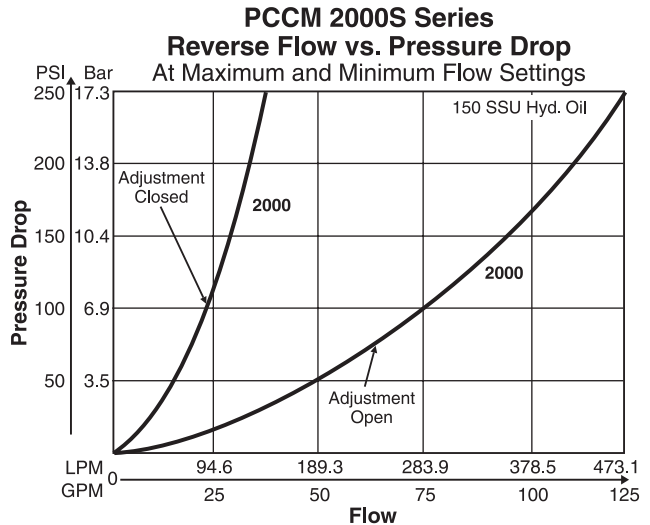
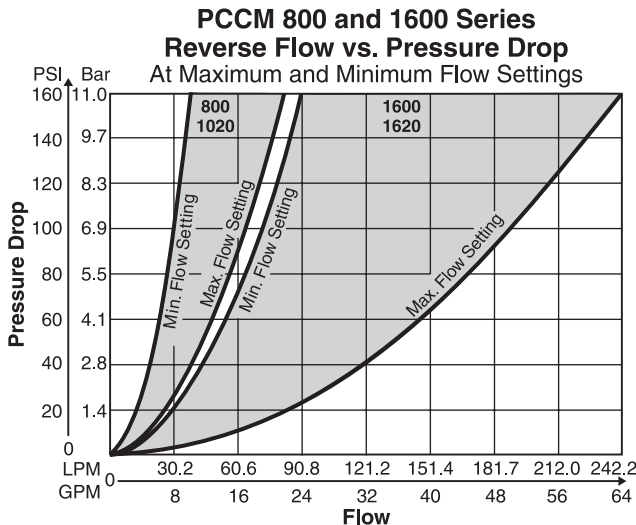
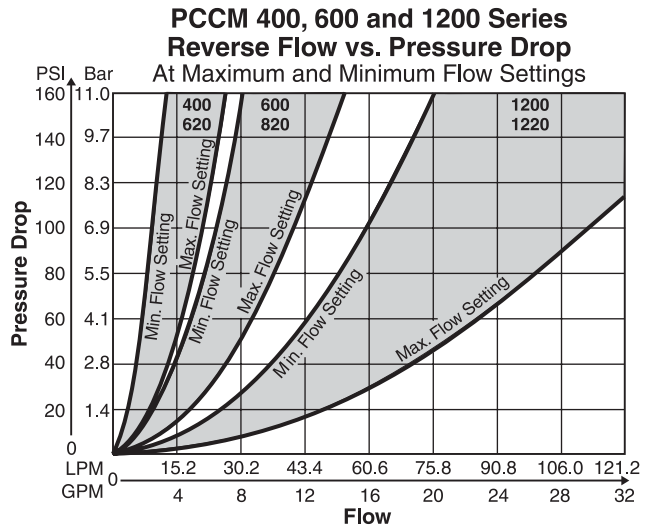
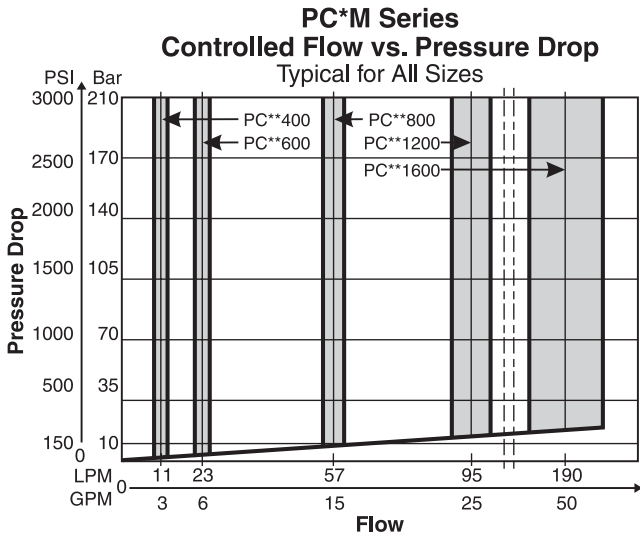

Inch equivalents for millimeter dimensions are shown in (**)

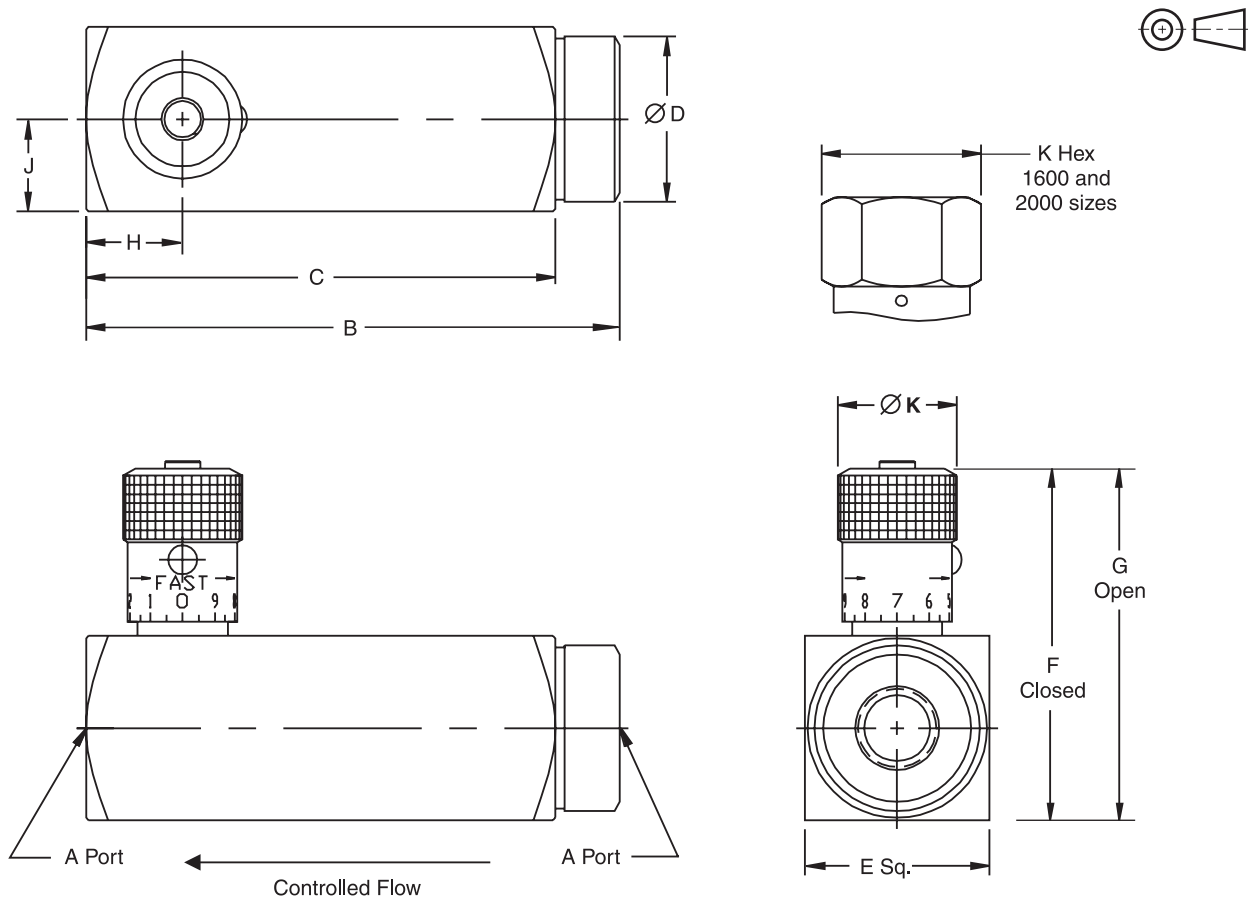

Model Number	Weights kg (lbs.)	A	B	C	D	E	F	G	H	J	K
PC*M400/620	0.8 (1.8)	1/4-18 NPTF 9/16-18 UNF	92.2 (3.63)	81.0 (3.19)	28.7 (1.13)	35.1 (1.38)	64.0 (2.52)	69.3 (2.73)	16.8 (0.66)	17.5 (0.69)	20.6 (0.81)
PC*M600/820	1.0* (2.2)*	3/8-18 NPTF 3/4-16 UNF	105.7 (4.16)	93.0 (3.66)	31.8 (1.25)	38.1 (1.50)	73.7 (2.90)	80.0 (3.15)	17.5 (0.69)	19.1 (0.75)	25.4 (1.00)
PC*M800/1020	1.7 (3.7)	1/2-14 NPTF 7/8-14 UNF	125.5 (4.94)	109.5 (4.31)	38.1 (1.50)	44.5 (1.75)	95.0 (3.74)	102.6 (4.04)	22.4 (0.88)	22.4 (0.88)	30.2 (1.19)
PC*M1200/1220	3.6 (8.0)	3/4-14 NPTF 1 1/16-12 UNF	149.4 (5.88)	130.3 (5.13)	50.8 (2.00)	57.2 (2.25)	115.8 (4.56)	128.5 (5.06)	27.7 (1.09)	28.7 (1.13)	35.1 (1.38)
PC*M1600/1620	6.6 (14.6)	1-11 1/2 NPTF 1 5/16-12 UNF	176.3 (6.94)	155.7 (6.13)	63.5 (2.50)	69.9 (2.75)	158.2 (6.23)	175.3 (6.90)	33.3 (1.31)	35.1 (1.38)	47.8 (1.88)
PC*M2000	11.8 (26.0)	1 1/4-11 1/2 NPTF	212.9 (8.38)	190.5 (7.50)	76.2 (3.00)	88.9 (3.50)	182.1 (7.17)	201.2 (7.92)	41.4 (1.63)	44.5 (1.75)	47.8 (1.88)

* Weights are for PC*M600; weights for PC*M820 are 1.4 kg (3.1lbs.)

General Description

Series N needle valves are ideal as speed controls on hydraulic and pneumatic systems where a reverse flow check is not needed. They provide excellent control and a reliable shut-off in a very small envelope.

Operation

A two-step needle allows fine adjustment at low flow by using the first three turns of the adjusting knob. The next three turns open the valve to full flow, and also provide standard throttling adjustments.

Features

- The exclusive “Colorflow” color-band reference scale on the valve stem is a great convenience and time-saver in setting the valve originally and in returning it to any previous setting.
- A simple set screw locks the valve on any desired setting.
- A tamperproof option (T) feature is also available to prevent accidental or intentional adjustment of flow setting.

Specifications

Maximum Operating Pressure	Brass: 140 Bar (2000 PSI); except for N1600 brass which is 35 Bar (500 PSI) Steel & Stainless: 345 Bar (5000 PSI) for 200 thru 1220; Steel: 207 Bar (3000 PSI) for all other sizes
Material	Body: See ordering code Knob: Steel - Zinc plated Needle: 416 Stainless Steel Stainless Steel: 303 Stainless Steel Bodies: 303 Stainless Steel
Temperature Range of Seal Compound	-40°C to +121°C (-40°F to +250°F) Nitrile (standard) -26°C to +205°C (-15°F to +400°F) Fluorocarbon

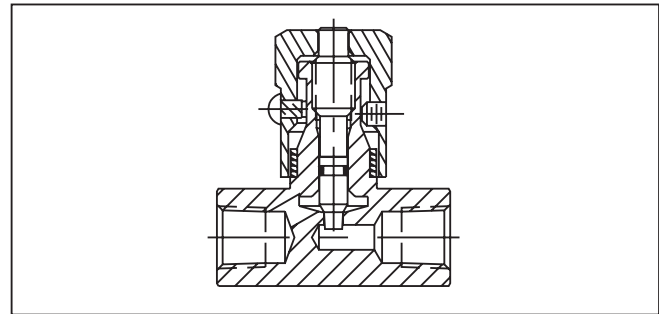
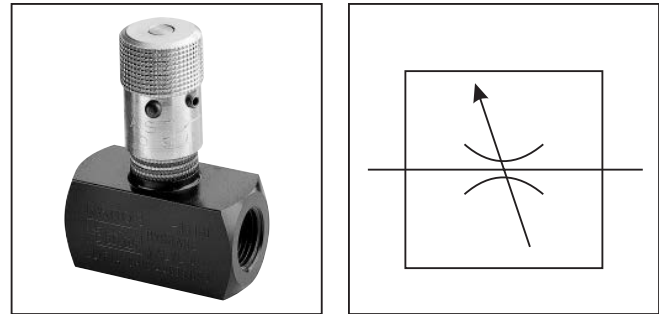

Performance Curves

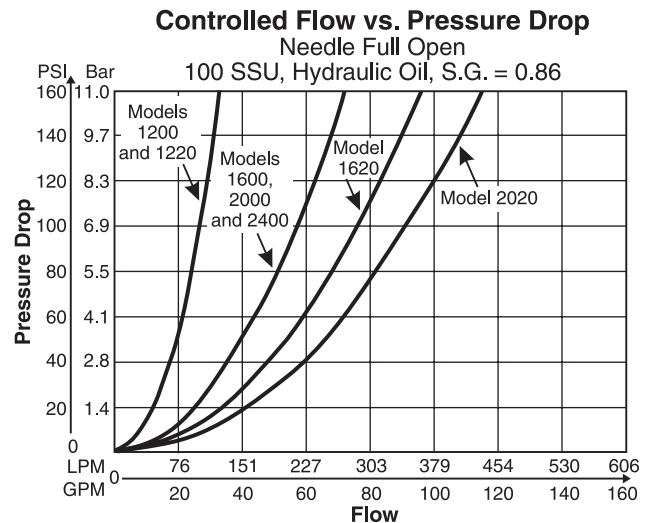
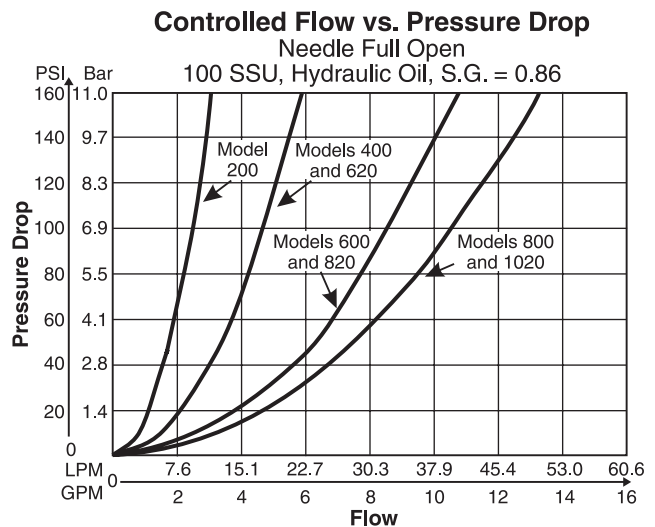

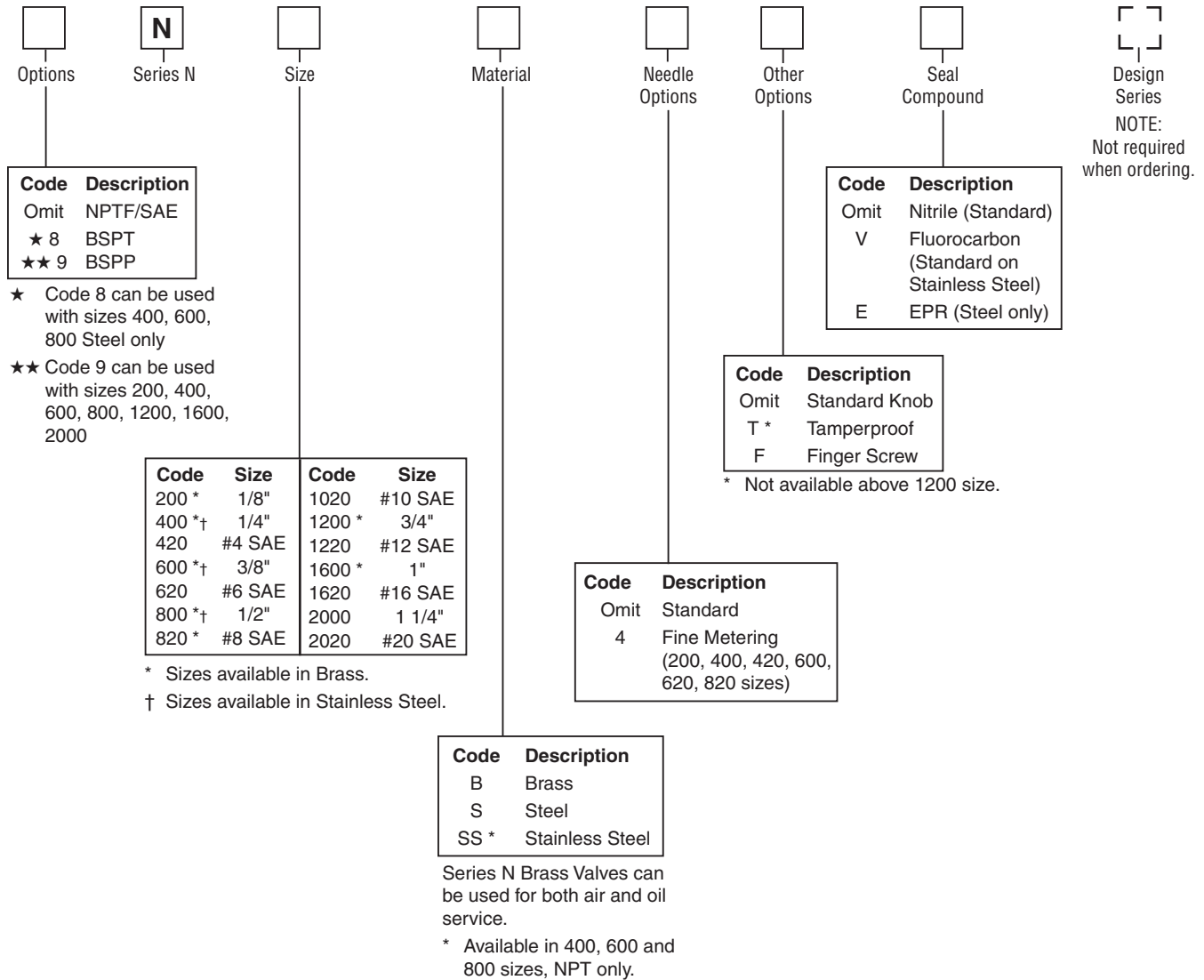

Model Number	Max Flow LPM (GPM)	Effective Orifice Area Control Flow in. ²	Effective Control Flow C _v
N200	11 (3)	0.0102	0.230
N420	11 (3)	0.0102	0.230
N400	19 (5)	0.0194	0.443
N620	19 (5)	0.0194	0.443
N600	30 (8)	0.0344	0.787
N820	30 (8)	0.0344	0.787
N800	57 (15)	0.0427	0.976
N1020	57 (15)	0.0427	0.976
N1200	95 (25)	0.1080	2.470
N1220	95 (25)	0.1080	2.470
N1600	151 (40)	0.2300	5.250
N1620	151 (40)	0.3070	7.000
N2000	264 (70)	0.2300	5.250
N2020	264 (70)	0.3710	8.470

Model Number	Effective Orifice Area Control Flow in. ²	Effective Control Flow C _v
N400-4	0.0044	0.0758
N600-4	0.0097	0.153
N620-4	0.0044	0.0758
N820-4	0.0097	0.153

Inch equivalents for millimeter dimensions are shown in (**)

Knob Options

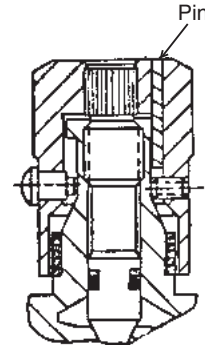
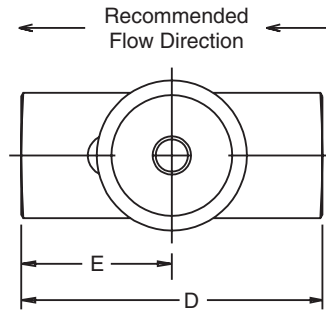

Tamperproof Option (Code "T") permanently locks knob at desired flow setting by installing a pin in predrilled hole.

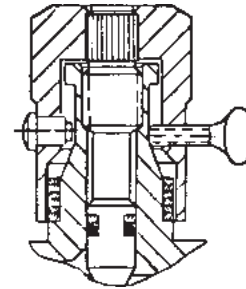

Finger screw Option (Code "F") provides this thumb-screw in place of set screw.

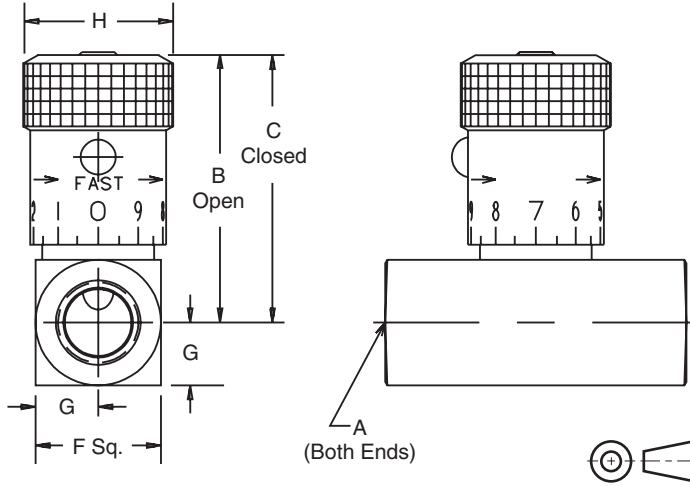

Model Number	Weight kg (lbs.)	A	B	C	D	E	F	G	H
N200	0.1 (0.3)	1/8-27 NPTF	39.1 (1.54)	35.3 (1.39)	38.1 (1.50)	19.1 (0.75)	15.7 (0.62)	7.9 (0.31)	19.1 (0.75)
N400	0.2 (0.5)	1/4-18 NPTF	45.5 (1.79)	40.4 (1.59)	50.8 (2.00)	25.4 (1.00)	20.6 (0.81)	10.4 (0.41)	20.6 (0.81)
N420	0.1 (0.3)	7/16-20 UNF #4 SAE	41.4 (1.63)	37.6 (1.48)	50.8 (2.00)	25.4 (1.00)	20.6 (0.81)	10.4 (0.41)	19.1 (0.75)
N600	0.4 (0.9)	3/8-18 NPTF	55.4 (2.18)	49.5 (1.95)	63.5 (2.50)	31.8 (1.25)	25.4 (1.00)	12.7 (0.50)	25.4 (1.00)
N620	0.2 (0.5)	9/16-18 UNF #6 SAE	47.8 (1.88)	42.7 (1.68)	60.5 (2.38)	30.2 (1.19)	25.4 (1.00)	12.7 (0.50)	20.6 (0.81)
N800	0.6 (1.3)	1/2-14 NPTF	68.6 (2.70)	61.5 (2.42)	66.5 (2.62)	33.3 (1.31)	31.8 (1.25)	15.7 (0.62)	30.2 (1.19)
N820	0.4 (0.9)	3/4-16 UNF #8 SAE	56.9 (2.24)	51.1 (2.01)	76.2 (3.00)	38.1 (1.50)	28.4 (1.12)	14.2 (0.56)	25.4 (1.00)
N1020	0.6 (1.3)	7/8-14 UNF #10 SAE	68.6 (2.70)	61.5 (2.42)	88.9 (3.50)	44.5 (1.75)	31.8 (1.25)	15.7 (0.62)	30.2 (1.19)
N1200	1.0 (2.2)	3/4-14 NPTF	85.9 (3.38)	71.4 (2.81)	82.6 (3.25)	41.1 (1.62)	38.1 (1.50)	19.1 (0.75)	35.1 (1.38)
N1220	1.0 (2.2)	1 1/6-12 UN #12 SAE	85.9 (3.38)	71.4 (2.81)	101.6 (4.00)	50.8 (2.00)	38.1 (1.50)	19.1 (0.75)	35.1 (1.38)
N1600	2.1 (4.6)	1-11 1/2 NPTF	123.7 (4.87)	106.9 (4.21)	108.0 (4.25)	53.8 (2.12)	44.5 (1.75)	22.4 (0.88)	47.8 * (1.88)
N1620	2.1 (4.6)	1 5/16-12 UN #16 SAE	130.8 (5.15)	114.0 (4.49)	108.0 (4.25)	53.8 (2.12)	57.2 (2.25)	28.4 (1.12)	47.8 * (1.88)
N2000	2.9 (6.4)	1 1/4-11 1/2 NPTF	130.0 (5.12)	113.3 (4.46)	108.0 (4.25)	53.8 (2.12)	57.2 (2.25)	28.4 (1.12)	47.8 * (1.88)
N2020	2.9 (6.4)	1 5/8-12 UN #20 SAE	140.2 (5.52)	123.4 (4.86)	114.3 (4.50)	57.2 (2.25)	69.9 (2.75)	60.5 (2.38)	47.8 * (1.88)

* = Hex

General Description

Series 6N needle valves are ideal as speed controls on hydraulic and pneumatic systems where a reverse flow check is not needed. They provide excellent control and a reliable shut-off in a very small envelope.

Operation

A two-step needle allows fine adjustment at low flow by using the first three turns of the adjusting knob. The next three turns open the valve to full flow, and also provide standard throttling adjustments.

Features

- Meets ISO 6149 standards.
- Hard metric dimensions.
- Reliable leak-free performance — straight thread port with o-ring sealing.
- Global interchangeability.

Specifications

Maximum Operating Pressure	345 Bar (5000 PSI)
Maximum Flow	M16 x 1.5 19 LPM (5 GPM) M18 x 1.5 30 LPM (8 GPM) M22 x 1.5 57 LPM (15 GPM) M27 x 2.0 95 LPM (25 GPM)
Material	Body ASTM 12L14 Carbon Steel Knob ASTM 12L14 Carbon Steel Needle ASTM 416 Stainless Steel
Temperature Range of Seal Compound	-40°C to +121°C (-40°F to +250°F) Nitrile (Standard)

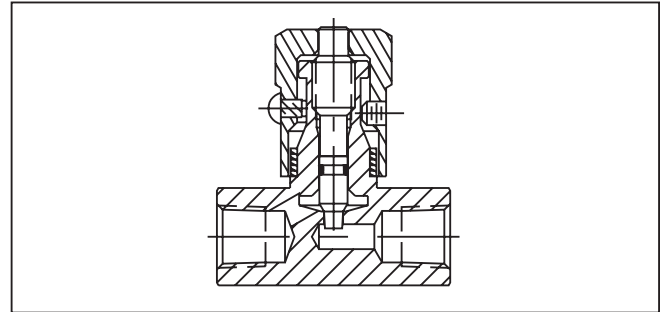
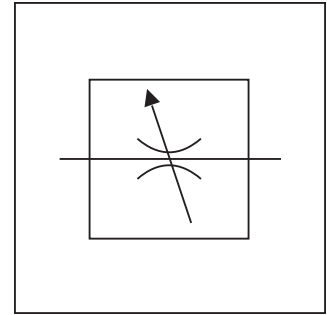

Performance Curves

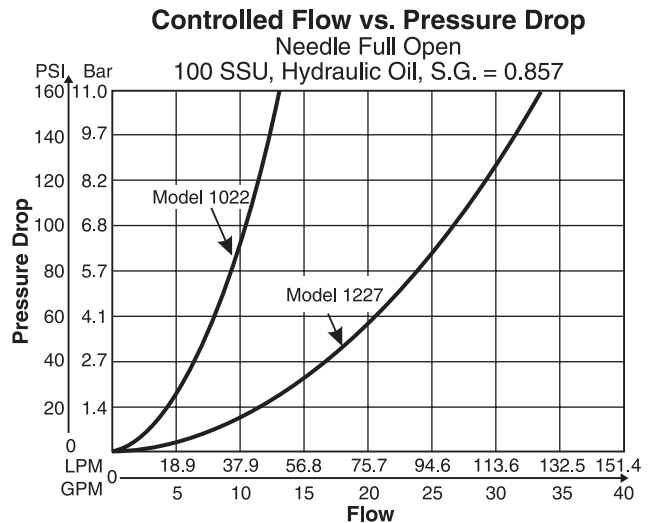
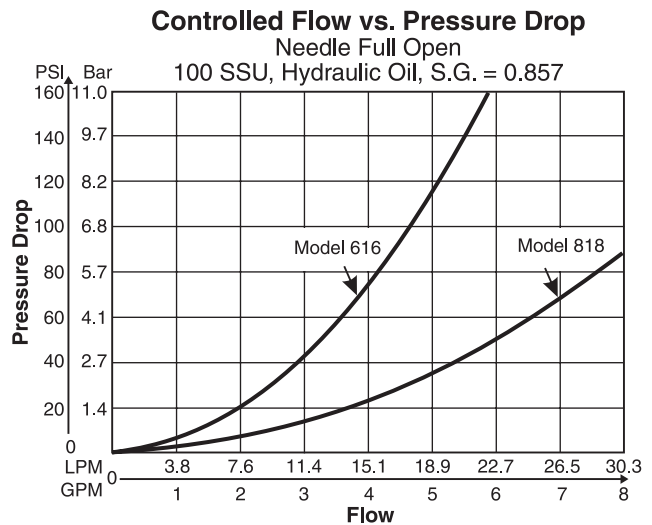

Ordering Information

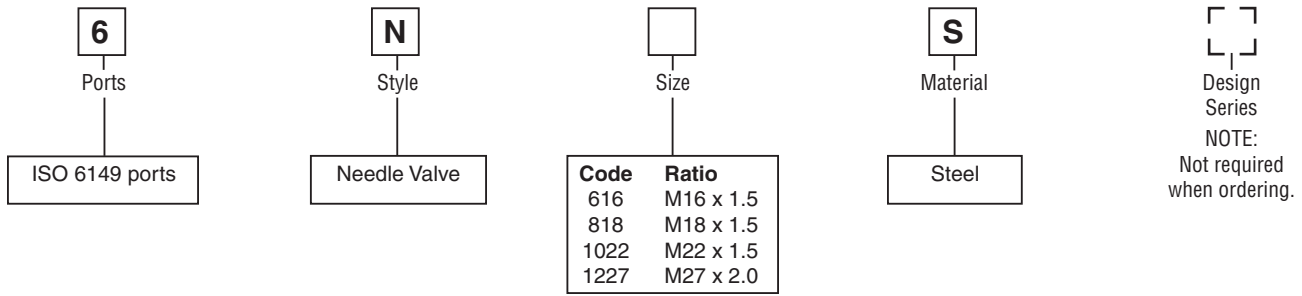

Dimensions

Inch equivalents for millimeter dimensions are shown in (**)

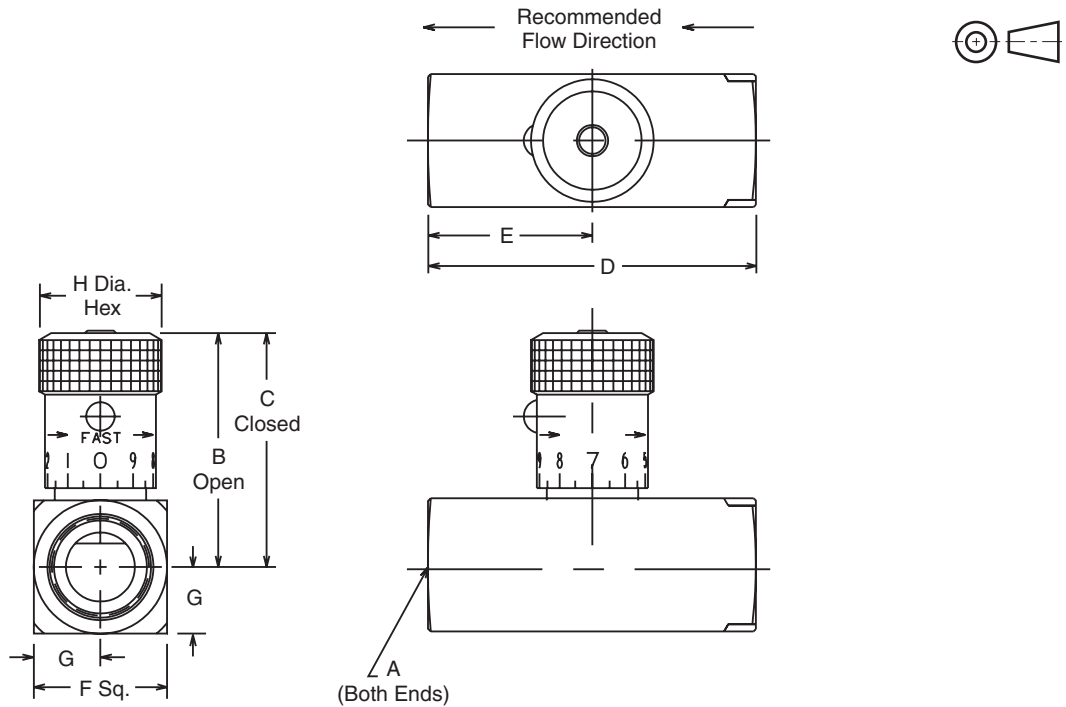

Model Number	Weight kg (lbs.)	A	B	C	D	E	F	G	H
6N616	0.2 (0.5)	M16 x 1.5	47.8 (1.88)	42.7 (1.68)	60.5 (2.38)	30.2 (1.19)	25.4 (1.00)	12.7 (0.50)	20.6 \varnothing (0.81)
6N818	0.4 (0.9)	M18 x 1.5	56.9 (2.24)	51.1 (2.01)	76.2 (3.00)	38.1 (1.50)	28.4 (1.12)	14.2 (0.56)	25.4 \varnothing (1.00)
6N1022	0.6 (1.3)	M22 x 1.5	68.6 (2.70)	61.5 (2.42)	88.9 (3.50)	44.5 (1.75)	31.8 (1.25)	15.7 (0.62)	30.2 \varnothing (1.19)
6N1227	1.0 (2.2)	M27 x 2.0	85.9 (3.38)	71.4 (2.81)	101.6 (4.00)	50.8 (2.00)	38.1 (1.50)	19.1 (0.75)	35.1 \varnothing (1.38)

General Description

Series MV high-precision metering and shut-off valves allow extremely close control of fluids used in actuating and governing equipment.

Operation

The standard needle allows fine adjustment at low flow by using the first three turns of the adjusting knob. The next three turns open the valve to full flow, and also provide standard throttling adjustments.

Features

- The exclusive “Colorflow” color-band reference scale on the valve stem is a great convenience and time-saver in setting the valve originally and in returning it to any previous setting.
- Fine and Micro-fine needles available for extremely fine control.
- MVK mounting kit makes panel mounting simple.
- High efficiency o-ring stem seal that eliminates packing.

Specifications

Maximum Operating Pressure	Brass: 140 Bar (2000 PSI) Steel: 413 Bar (6000 PSI) for MV261, 461, 661, 861. 345 Bar (5000 PSI) for MV200, 400, 401, 420, 600, 601, 620, 800, 820, 1020, 1200, 1220. 207 Bar (3000 PSI) for all other sizes and styles.
Material	Body: See ordering code Handle: Zinc alloy - Zinc chromate Needle: 416 Stainless Steel
Temperature Range of Seal Compound	-40°C to +121°C (-40°F to +250°F) Nitrile (standard) -26°C to +205°C (-15°F to +400°F) Fluorocarbon

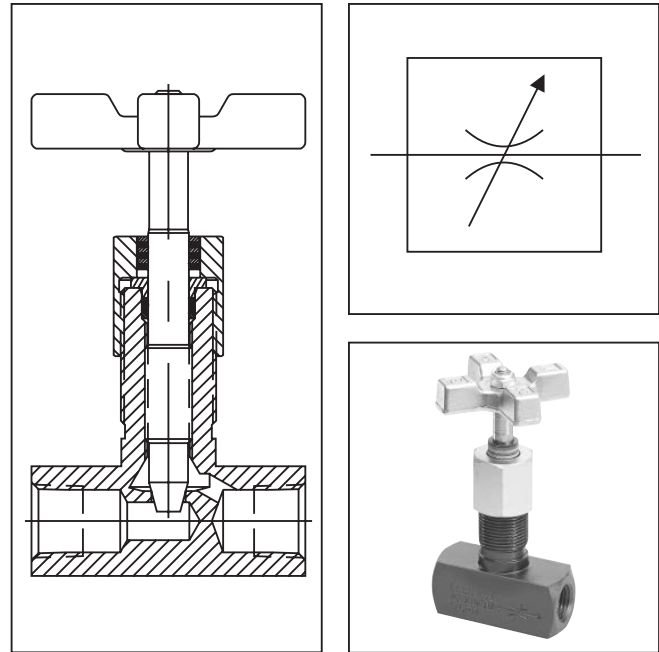

Performance Curves

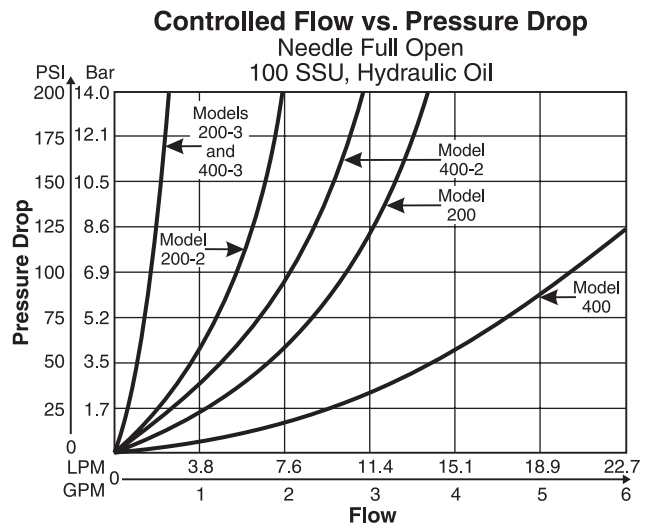
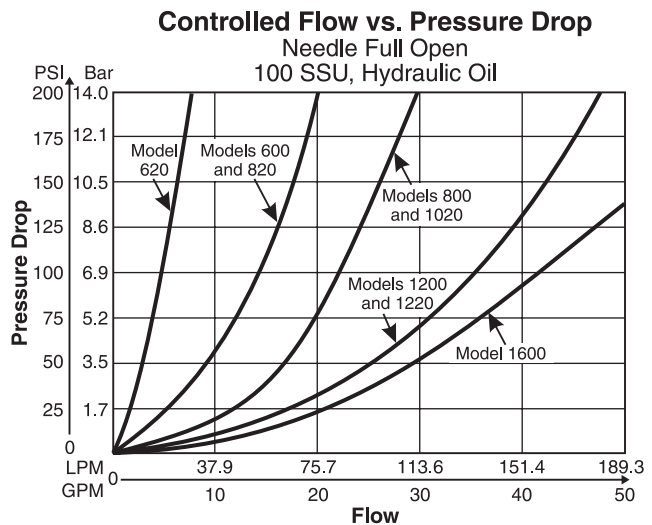

Ordering Information

Options

Code	Description
Omit	NPTF/SAE
★ 9	BSPB

★ Code 9 can be used with sizes 200, 261, 400, 461, 600, 661, 800, 861, 1200, 1261, and 1600.

Series MV

MV

Size

Code	Size	Code	Size
200 *	1/8"	661	3/8"
260	1/8"	681	#6 SAE
261	1/8"	800 *	1/2"
400 *	1/4"	820	#8 SAE
401	1/4"	860	1/2"
420	#4 SAE	861	1/2"
460	1/4"	1020	#10 SAE
461	1/4"	1200	3/4"
600 *	3/8"	1220	#12 SAE
601	3/8"	1261	3/4"
620	#6 SAE	-1600	1"
660	3/8"	-1620	#16 SAE

* Sizes available in Brass

00 is Female to Female
 01 is Female to Male
 6* is Right Angle
 60 is Male to Female
 61 is Female to Female

Material

Code	Description
B	Brass
S	Steel

Needle Options

Code	Description
Omit	Standard 30° Taper
2	Fine
3	Micro-fine

2 and 3 not available in sizes 660 and above.

Seal Compound

Code	Description
Omit	Nitrile (Standard)
V	Fluorocarbon

Design Series

NOTE:
 Not required when ordering.

Mounting Kit

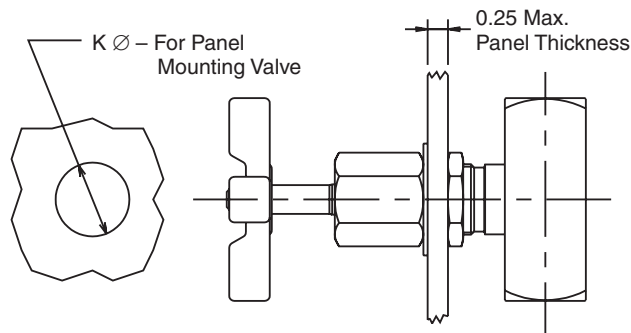

Panel Mounting Kits					
Kit Number	K	Valve Model	Kit Number	K	Valve Model
MVK2	15.0 (0.59)	MV200	MVK8	29.5 (1.16)	MV800
		MV260			MV860
		MV261S			MV861S
		MV420			MV1020
MVK4	19.8 (0.78)	MV400	MVK12	35.8 (1.41)	MV1200
		MV401			MV1220
		MV460S			MV1261
		MV461S	MVK16	35.8 (1.41)	MV-1600
MV620	MV-1620				
MVK6	23.1 (0.91)	MV600			
		MV601			
		MV660			
		MV661S			
		MV681			
		MV820			

Model Number	Effective Orifice Area Max Flow LPM (GPM)	Control Flow in. ²	Effective Control Flow C _v
MV200	11 (3)	0.0107	0.244
MV260	11 (3)	0.0107	0.244
MV261	11 (3)	0.0107	0.244
MV420	11 (3)	0.0107	0.244
MV200-2	7 (1.8)	0.0053	0.121
MV260-2	7 (1.8)	0.0053	0.121
MV261-2	7 (1.8)	0.0053	0.121
MV420-2	7 (1.8)	0.0053	0.121
MV200-3	2 (0.5)	0.0014	0.032
MV260-3	2 (0.5)	0.0014	0.032
MV261-3	2 (0.5)	0.0014	0.032
MV420-3	2 (0.5)	0.0014	0.032
MV400	19 (5)	0.0216	0.493
MV460	19 (5)	0.0216	0.493
MV461	19 (5)	0.0216	0.493
MV620	19 (5)	0.0216	0.493
MV400-2	11 (2.8)	0.0081	0.186
MV460-2	11 (2.8)	0.0081	0.186
MV461-2	11 (2.8)	0.0081	0.186
MV620-2	11 (2.8)	0.0081	0.186
MV400-3	2 (0.5)	0.0017	0.039
MV460-3	2 (0.5)	0.0017	0.039
MV461-3	2 (0.5)	0.0017	0.039
MV620-3	2 (0.5)	0.0017	0.039
MV600	30 (8)	0.0567	1.294
MV660	30 (8)	0.0567	1.294
MV661	30 (8)	0.0567	1.294
MV681	30 (8)	0.0567	1.294
MV820	30 (8)	0.0567	1.294
MV600-2	1.8 (0.5)	0.018	0.466
MV600-3	0.28 (0.1)	0.0027	0.0326
MV800	57 (15)	0.0845	1.930
MV860	57 (15)	0.0845	1.930
MV861	57 (15)	0.0845	1.930
MV1020	57 (15)	0.0845	1.930
MV1200	95 (25)	0.1400	3.205
MV1220	95 (25)	0.1400	3.205
MV1261	95 (25)	0.1400	3.205
MV-1600	151 (40)	0.1675	3.829
MV-1620	151 (40)	0.1675	3.829

Inch equivalents for millimeter dimensions are shown in (**)

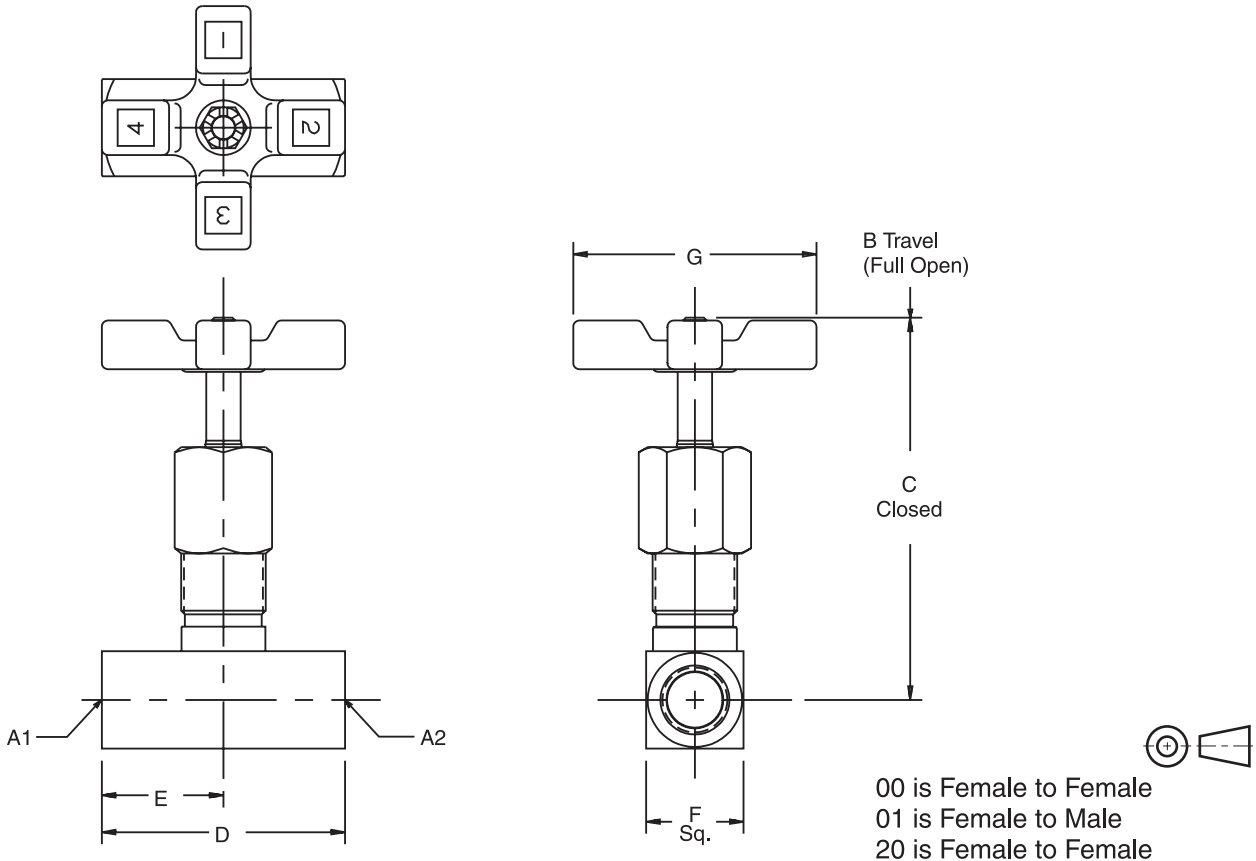

Model Number	Weight kg (lbs.)	A1	A2	B	C	D	E	F	G
MV200	0.1 (0.3)	1/8-27 NPTF Female	1/8-27 NPTF Female	69.1 (2.72)	63.8 (2.51)	38.1 (1.50)	19.1 (0.75)	15.7 (0.62)	44.5 (1.75)
MV420	0.1 (0.3)	7/16-20 UNF #4 SAE	7/16-20 UNF #4 SAE	71.6 (2.82)	66.3 (2.61)	50.8 (2.00)	25.4 (1.00)	20.6 (0.81)	44.5 (1.75)
MV400	0.3 (0.7)	1/4-18 NPTF Female	1/4-18 NPTF Female	86.9 (3.42)	81.5 (3.21)	50.8 (2.00)	25.4 (1.00)	20.6 (0.81)	50.8 (2.00)
MV401	0.3 (0.7)	1/4-18 NPTF Male	1/4-18 NPTF Female	86.9 (3.42)	81.5 (3.21)	55.4 (2.18)	30.0 (1.18)	20.6 (0.81)	50.8 (2.00)
MV620	0.5 (1.1)	9/16-18 UNF #6 SAE	9/16-18 UNF #6 SAE	89.2 (3.51)	83.8 (3.30)	60.5 (2.38)	30.2 (1.19)	25.4 (1.00)	50.8 (2.00)
MV600	0.5 (1.1)	3/8-18 NPTF Female	3/8-18 NPTF Female	99.6 (3.92)	91.9 (3.62)	63.5 (2.50)	31.8 (1.25)	25.4 (1.00)	63.5 (2.50)
MV601	0.5 (1.1)	3/8-18 NPTF Male	3/8-18 NPTF Female	99.6 (3.92)	91.9 (3.62)	68.1 (2.68)	36.3 (1.43)	25.4 (1.00)	63.5 (2.50)
MV820	0.5 (1.1)	3/4-16 UNF #8 SAE	3/4-16 UNF #8 SAE	108.7 (4.28)	101.1 (3.98)	76.2 (3.00)	38.1 (1.50)	28.4 (1.12)	63.5 (2.50)
MV800	1.0 (2.2)	1/2-14 NPTF Female	1/2-14 NPTF Female	129.3 (5.09)	116.6 (4.59)	66.5 (2.62)	33.3 (1.31)	31.8 (1.25)	82.6 (3.25)
MV1020	1.0 (2.2)	7/8-14 UNF #10 SAE	7/8-14 UNF #10 SAE	129.5 (5.10)	116.6 (4.59)	88.9 (3.50)	44.5 (1.75)	31.8 (1.25)	82.6 (3.25)
MV1200	1.6 (3.5)	3/4-14 NPTF Female	3/4-14 NPTF Female	141.8 (5.58)	127.8 (5.03)	82.6 (3.25)	41.1 (1.62)	38.1 (1.50)	98.6 (3.88)
MV1220	1.6 (3.5)	1 1/16-12 UN #12 SAE	1 1/16-12 UN #12 SAE	141.8 (5.58)	127.8 (5.03)	101.6 (4.00)	50.8 (2.00)	38.1 (1.50)	98.6 (3.88)
MV-1600	1.9 (4.2)	1-11 1/2 NPTF Female	1-11 1/2 NPTF Female	146.8 (5.78)	132.8 (5.23)	108.0 (4.25)	53.8 (2.12)	44.5 (1.75)	98.6 (3.88)
MV-1620	1.9 (4.2)	1 5/16-12 UN #16 SAE	1 5/16-12 UN #16 SAE	152.9 (6.02)	138.9 (5.47)	108.0 (4.25)	53.8 (2.12)	57.2 (2.25)	98.6 (3.88)

An optional MVK mounting kit makes panel mounting quite simple.

Inch equivalents for millimeter dimensions are shown in (**)

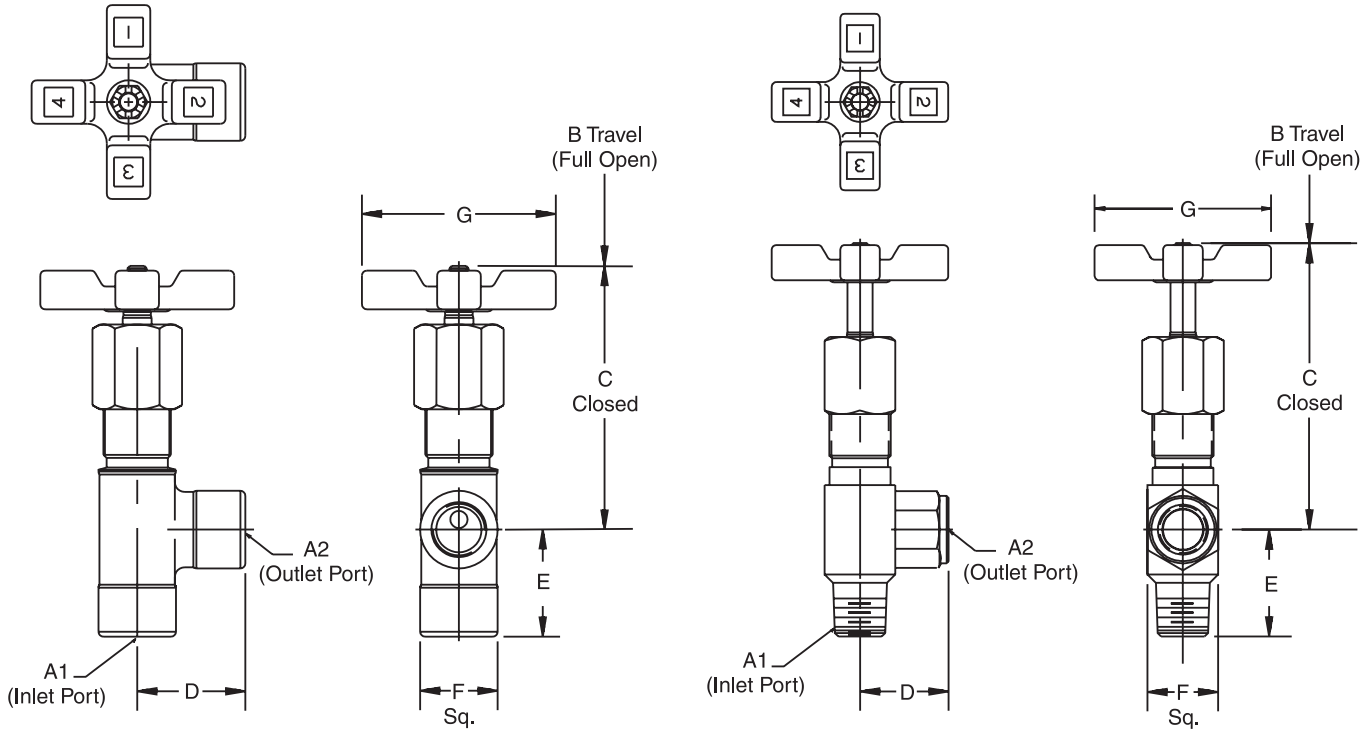

61 is Female to Female

60 is Male to Female

Model Number	Weight kg (lbs.)	A1	A2	B	C	D	E	F	G
MV260	0.1 (0.3)	1/8-27 NPTF Male	1/8-27 NPTF Female	72.4 (2.85)	67.1 (2.64)	19.1 (0.75)	22.1 (0.87)	15.7 (0.62)	44.5 (1.75)
MV460	0.3 (0.7)	1/4-18 NPTF Male	1/4-18 NPTF Female	90.2 (3.55)	84.8 (3.34)	27.2 (1.07)	30.7 (1.21)	20.6 (0.81)	50.8 (2.00)
MV660	0.5 (1.1)	3/8-18 NPTF Male	3/8-18 NPTF Female	110.7 (4.36)	103.1 (4.06)	31.8 (1.25)	34.8 (1.37)	25.4 (1.00)	63.5 (2.50)
MV860	0.9 (2.0)	1/2-14 NPTF Male	1/2-14 NPTF Female	133.4 (5.25)	120.7 (4.75)	36.8 (1.45)	42.7 (1.68)	31.8 (1.25)	82.6 (3.25)
MV261	0.1 (0.3)	1/8-27 NPTF Female	1/8-27 NPTF Female	93.98 (3.70)	60.7 (2.39)	26.9 (1.06)	26.9 (1.06)	17.5 (0.69)	44.5 (1.75)
MV461	0.3 (0.7)	1/4-18 NPTF Female	1/4-18 NPTF Female	86.1 (3.39)	76.4 (3.01)	33.5 (1.32)	31.2 (1.23)	22.3 (0.88)	50.8 (2.00)
MV661	0.5 (1.1)	3/8-18 NPTF Female	3/8-18 NPTF Female	98.04 (3.86)	86.4 (3.40)	38.3 (1.51)	35.0 (1.38)	25.4 (1.00)	63.5 (2.50)
MV861	1.0 (2.2)	1/2-14 NPTF Female	1/2-14 NPTF Female	118.3 (4.66)	106.9 (4.21)	43.43 (1.71)	40.3 (1.59)	29.4 (1.16)	82.6 (3.25)
MV1261	1.6 (3.5)	3/4-14 NPTF Female	3/4-14 NPTF Female	146.8 (5.78)	132.8 (5.23)	44.5 (1.75)	41.1 (1.62)	38.1 (1.50)	98.6 (3.88)

An optional MVK mounting kit makes panel mounting quite simple.

General Description

Series MVI cartridge-type needle valves are designed for installation in a precision-machined cavity made in the manifold of the machine. Detailed instructions for machining the required cavity for the valve are given on page 27.

Properly installed in precision-machined cavities, these needle valves provide precise metering control and full shutoff of flow. An o-ring and backup ring installed on the cartridge fully isolate the inlet and outlet ports of the machined cavity from each other.

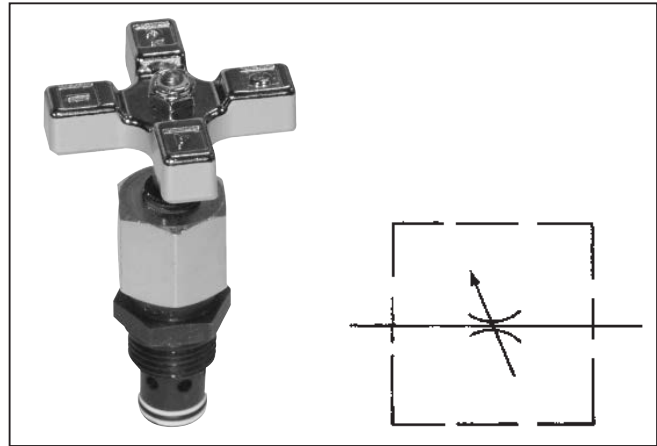

Features

- The exclusive “Colorflow” color-band reference scale on the valve stem is a great convenience and time-saver in setting the valve originally and in returning it to any previous setting.
- Fine and Micro-fine needles available for extremely fine control.
- High efficiency o-ring stem seal that eliminates packing.

Specifications

Maximum Operating Pressure	340 Bar (5000 PSI)
Flow	See table
Material	Steel, compatible in steel or aluminum manifold block cavities
Temperature Range of Seal Compound	-40°C to +121°C (-40°F to +250°F) Nitrile (standard) -26°C to +205°C (-15°F to +400°F) Fluorocarbon

Ordering Information

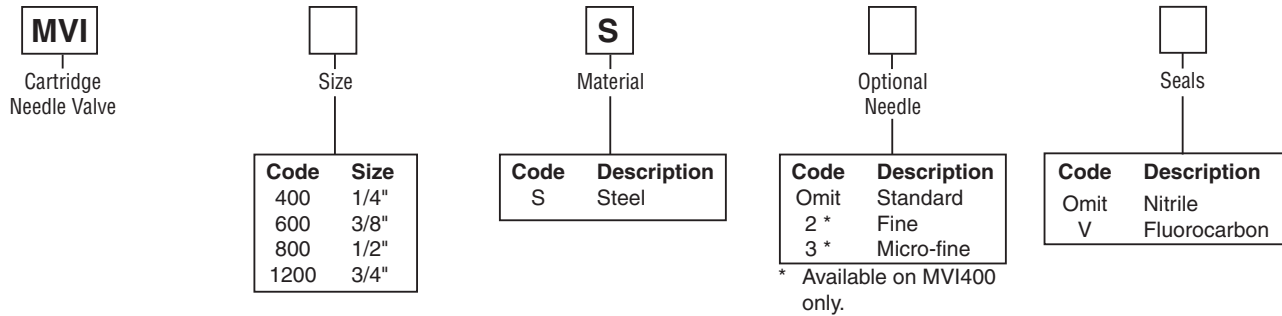

Flow Data

Valve Model	Maximum Flow	ΔP @ Maximum Flow	Orifice Area in ² Full Open	C _v * Factor	Valve Size
MVI400	19 LPM (5 GPM)	7 Bar (100 PSI)	0.0216	0.493	1/4"
MVI400-2	11 LPM (2.8 GPM)	14 Bar (200 PSI)	0.0081	0.186	1/4"
MVI400-3	2 LPM (0.5 GPM)	14 Bar (200 PSI)	0.0014	0.032	1/4"
MVI600	30 LPM (8 GPM)	2 Bar (35 PSI)	0.0567	1.294	3/8"
MVI800	57 LPM (15 GPM)	3 Bar (45 PSI)	0.0845	1.930	1/2"
MVI1200	95 LPM (25 GPM)	4 Bar (51 PSI)	0.1400	3.205	3/4"

* C_v factor – Flow of water in GPM that valve will pass @ ΔP of 0.1 Bar (1 PSI).

Performance Curves

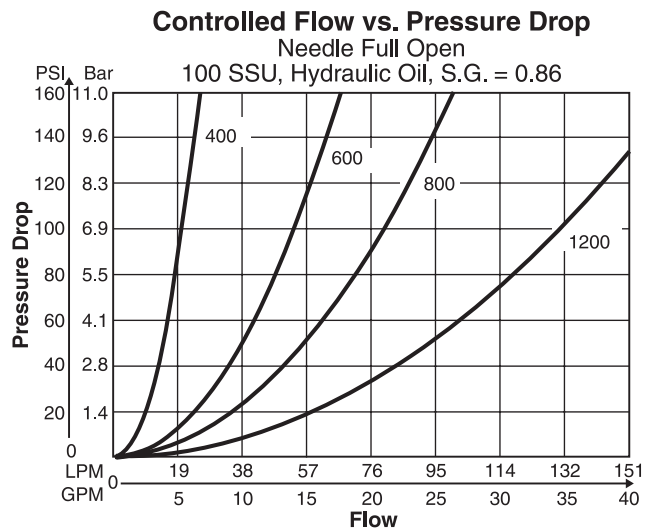
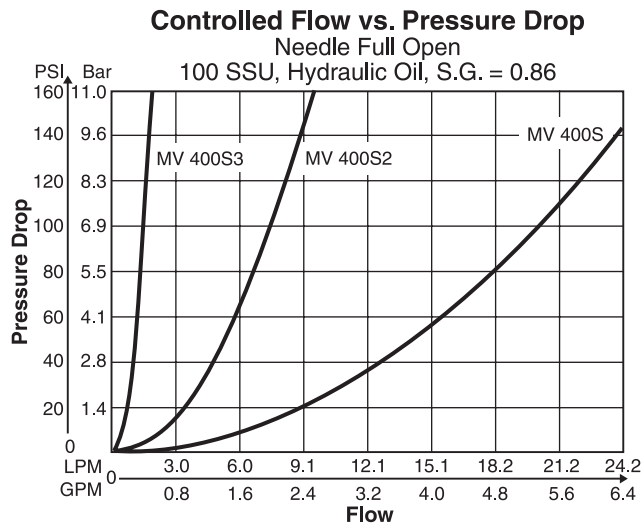

Inch equivalents for millimeter dimensions are shown in (**)

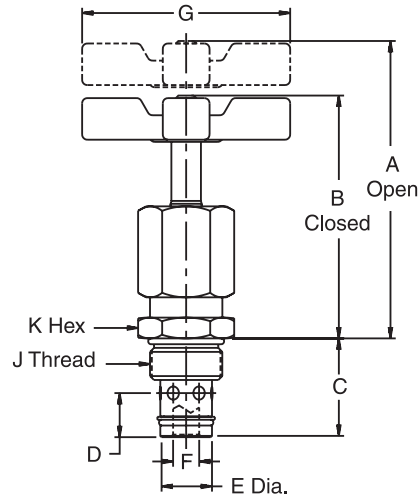

Model Number	A	B	C	D	E	F	G	J	K	Weight
MVI400S *	64.5 (2.54)	59.4 (2.34)	25.4 (1.00)	10.9 (0.43)	14.2 (0.56)	4.6 (0.18)	50.8 (2.00)	3/4-16UNF-2A	22.1 (0.87)	0.2 kg (0.4 lb.)
MVI600S	80.3 (3.16)	72.6 (2.86)	30.0 (1.18)	13.5 (0.53)	15.7 (0.62)	7.9 (0.31)	63.5 (2.50)	7/8-14UNF-2A	25.4 (1.00)	0.3 kg (0.6 lb.)
MVI800S	91.2 (3.59)	78.5 (3.09)	39.6 (1.56)	15.2 (0.60)	20.3 (0.80)	9.4 (0.37)	82.6 (3.25)	1 1/16-12UN-2A	31.8 (1.25)	0.5 kg (1.2 lb.)
MVI1200S	101.6 (4.00)	87.6 (3.45)	43.4 (1.71)	19.1 (0.75)	26.9 (1.06)	11.7 (0.46)	98.3 (3.87)	1 5/16-12UN-2A	38.1 (1.50)	0.9 kg (2.0 lb.)

Machining Detail Installation Cavity

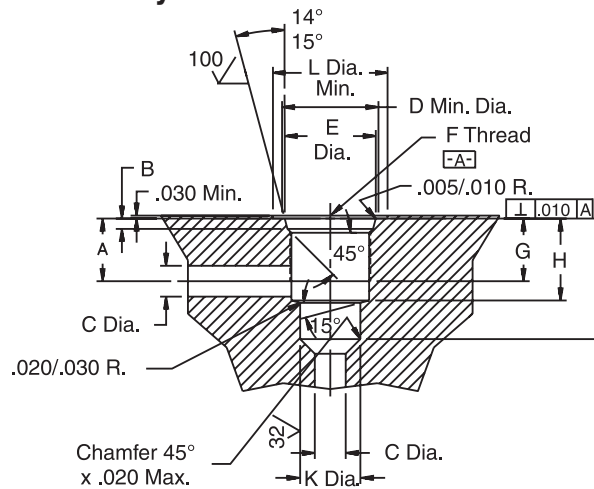

Model Number	A	B	C	D	E	F	G	H	J	K	L
MVI400S *	14.2 (0.56)	2.5/2.9 (0.100/0.115)	5.3 (0.21)	22.1 (0.87)	20.6/20.7 (0.811/0.816)	3/4-16 UNF-2B	14.2 (0.56)	17.8 (0.70)	26.9 (1.06)	14.3/14.3 (0.562/0.564)	30.2 (1.19)
MVI600S	16.5 (0.65)	2.5/2.9 (0.100/0.115)	8.1 (0.32)	25.4 (1.00)	23.9/24.1 (0.942/0.947)	7/8-14 UNF-2B	16.5 (0.65)	21.6 (0.85)	31.8 (1.25)	15.8/15.9 (0.624/0.626)	34.1 (1.34)
MVI800S	24.1 (0.95)	3.3/3.7 (0.130/0.145)	10.2 (0.40)	31.8 (1.25)	29.2/29.3 (1.148/1.153)	1 1/16-12 UN-2B	19.1 (0.75)	30.0 (1.18)	41.1 (1.62)	20.6/20.7 (0.811/0.813)	41.4 (1.63)
MVI1200S	24.6 (0.97)	3.3/3.7 (0.130/0.145)	12.7 (0.50)	38.1 (1.50)	35.5/35.6 (1.398/1.403)	1 5/16-12 UN-2B	19.1 (0.75)	31.8 (1.25)	45.2 (1.78)	26.9/27.0 (1.062/1.064)	48.5 (1.91)

General Description

Series C check valves permit free flow in one direction, and dependable shut-off in the reverse direction.

Operation

When pressure going through the valve is increased to the cracking level, the valve opens. When the pressure is reduced to below the cracking level, the valve closes.

Features

- Stainless steel poppets standard.
- Soft seal poppets are standard in some variations.
- Triangular retainers guide the poppets, and hold the spring firmly in place even under high velocity and shock.

Specifications

Maximum Operating Pressure	Brass: 140 Bar (2000 PSI); except for C1600 brass which is 35 Bar (500 PSI)
	Steel & Stainless: 345 Bar (5000 PSI) for 200 thru 1220; Steel: 207 Bar (3000 PSI) for all other sizes and styles
Material	Body: See ordering code Spring: 316 Stainless Steel Poppet: 416 Stainless Steel Retainer: 416 Stainless Steel Stainless Steel Bodies: 303 Stainless Steel
Poppets	Soft seal poppet is standard for 200 through 800/1020 size. For cracking pressures > 15 PSI, solid metal poppets are standard
Nominal Cracking Pressure	Standard: 0.4 Bar (5 PSI) Optional: 1.38 Bar (20 PSI), 4.48 Bar (65 PSI)
Temperature Range of Seal Compound	-40°C to +121°C (-40°F to +250°F) Nitrile (standard) -26°C to +205°C (-15°F to +400°F) Fluorocarbon

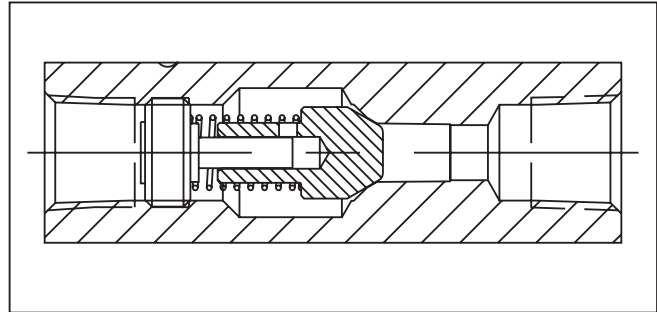
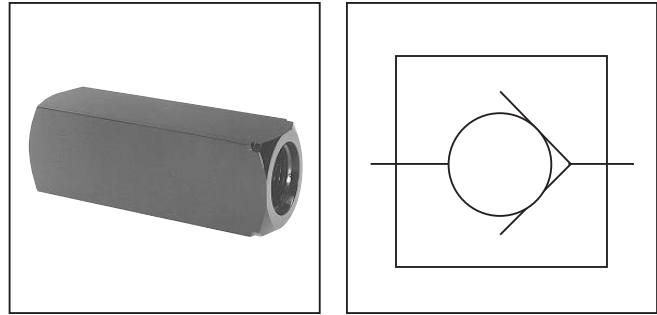

Performance Curves

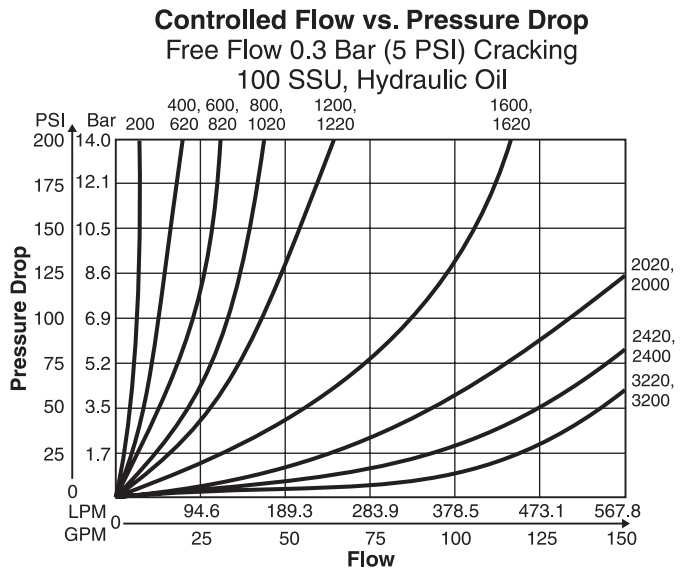

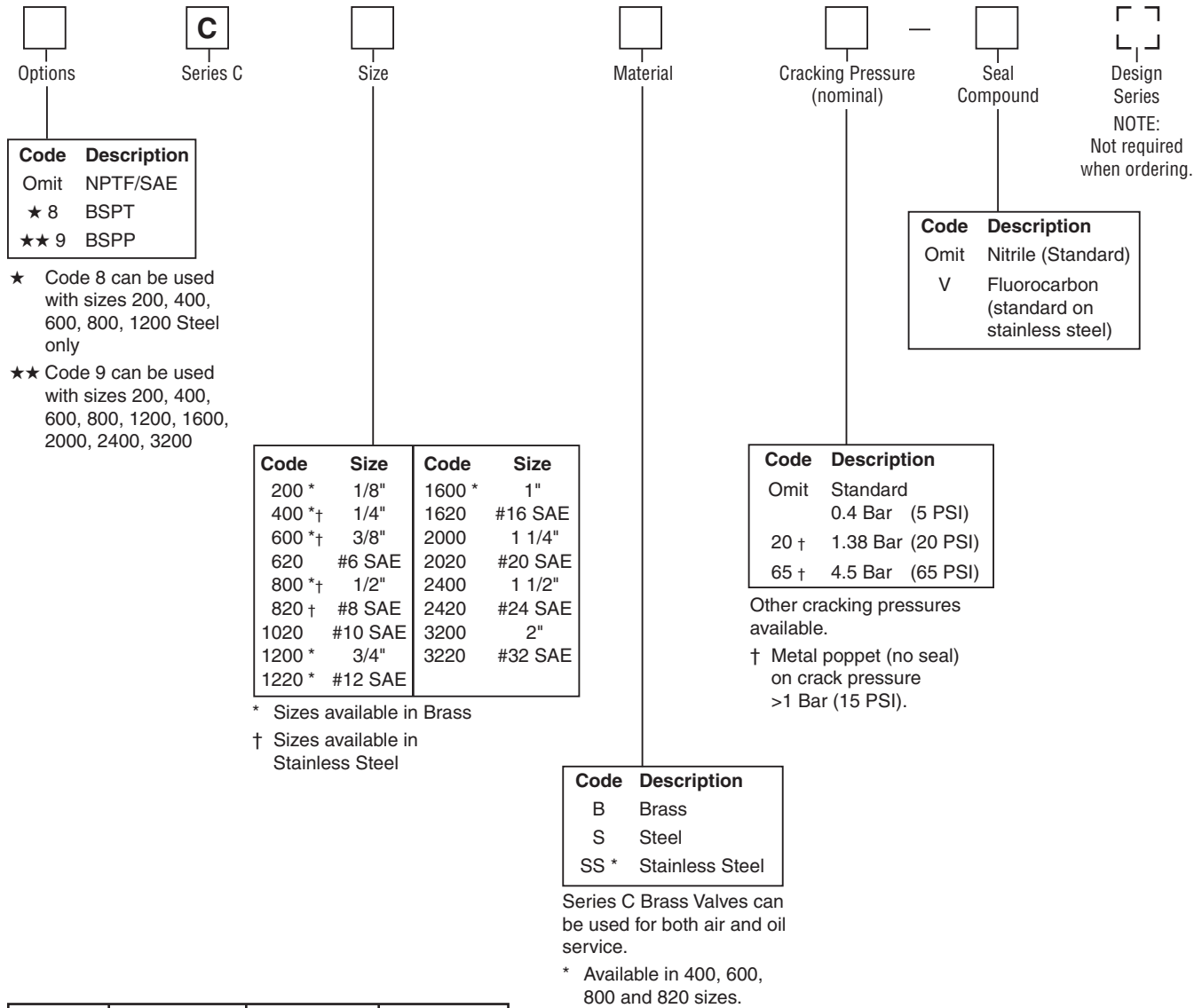

Model Number	Max Flow LPM (GPM)	Effective Orifice Area Control Flow in. ²	Effective Control Flow C _v
C200	11 (3)	0.023	0.53
C400	19 (5)	0.068	1.56
C620	19 (5)	0.068	1.56
C600	30 (8)	0.099	2.27
C820	30 (8)	0.099	2.27
C800	57 (15)	0.224	5.11
C1020	57 (15)	0.224	5.11
C1200	95 (25)	0.348	7.95
C1220	95 (25)	0.348	7.95
C1600	151 (40)	0.453	10.35
C1620	151 (40)	0.453	10.35
C2000	265 (70)	0.855	19.52
C2020	265 (70)	0.855	19.52
C2400	379 (100)	0.955	21.82
C2420	379 (100)	0.955	21.82
C3200	568 (150)	1.046	23.90
C3220	568 (150)	1.046	23.90

Inch equivalents for millimeter dimensions are shown in (**)

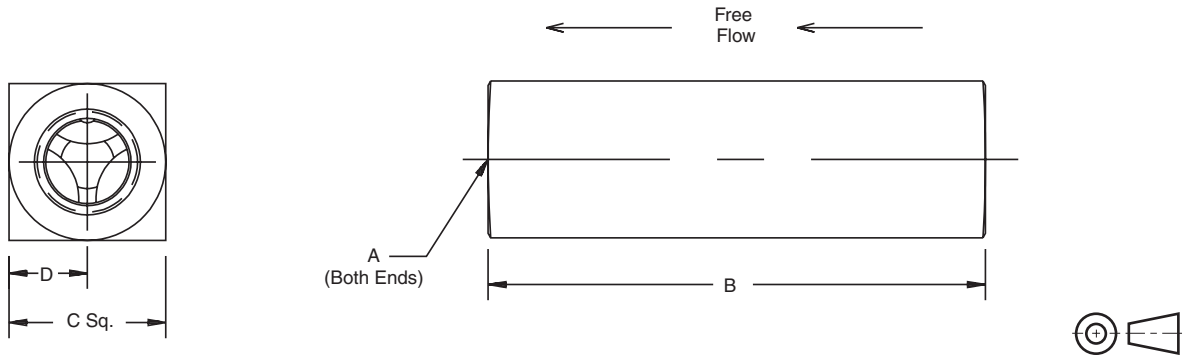

Model Number	Weight kg (lbs.)	A	B	C	D
C200	0.05 (0.1)	1/8-27 NPTF	50.8 (2.00)	16.0 (0.63)	7.9 (0.31)
C400	0.2 (0.4)	1/4-18 NPTF	66.8 (2.63)	20.6 (0.81)	10.4 (0.41)
C600	0.2 (0.5)	3/8-18 NPTF	69.9 (2.75)	25.4 (1.00)	12.7 (0.50)
C620	0.2 (0.5)	9/16-18 UNF #6 SAE	79.2 (3.12)	25.4 (1.00)	12.7 (0.50)
C800	0.6 (1.3)	1/2-14 NPTF	87.4 (3.44)	31.8 (1.25)	16.0 (0.63)
C820	0.3 (0.7)	3/4-16 UNF #8 SAE	88.9 (3.50)	28.4 (1.12)	14.2 (0.56)
C1020	0.6 (1.3)	7/8-14 UNF #10 SAE	101.6 (4.00)	31.8 (1.25)	15.7 (0.62)
C1200	0.9 (2.0)	3/4-14 NPTF	98.6 (3.88)	38.1 (1.50)	19.1 (0.75)
C1220	0.9 (2.0)	1 1/6-12 UN #12 SAE	117.3 (4.62)	38.1 (1.50)	19.1 (0.75)
C1600	1.5 (3.3)	1-11 1/2 NPTF	127.0 (5.00)	44.5 (1.75)	22.4 (0.88)
C1620	1.5 (3.3)	1 5/16-12 UN #16 SAE	142.7 (5.62)	57.2 (2.25)	28.4 (1.12)
C2000	2.8 (6.2)	1 1/4-11 1/2 NPTF	143.0 (5.63)	57.2 (2.25)	28.7 (1.13)
C2020	2.8 (6.2)	1 5/8-12 UN #20 SAE	165.1 (6.50)	69.9 (2.75)	35.1 (1.38)
C2400	3.8 (8.4)	1 1/2-11 1/2 NPTF	143.0 (5.63)	69.9 (2.75)	35.1 (1.38)
C2420	3.8 (8.4)	1 7/8-12 UN #24 SAE	184.2 (7.25)	76.2 (3.00)	38.1 (1.50)
C3200	7.0 (15.4)	2-11 1/2 NPTF	165.1 (6.50)	88.9 (3.50)	44.5 (1.75)
C3220	7.0 (15.4)	2 1/2-12 UN #32 SAE	228.6 (9.00)	101.6 (4.00)	50.8 (2.00)

General Description

Series 6C check valves provide free flow in one direction and dependable shut-off in the reverse direction.

Operation

When pressure going through the valve is increased to the cracking level, the valve opens. When the pressure is reduced to below the cracking level, the valve closes.

Features

- Meets ISO 6149 standards
- Hard metric dimensions.
- Reliable leak-free performance — straight thread port with o-ring sealing.
- Global interchangeability.

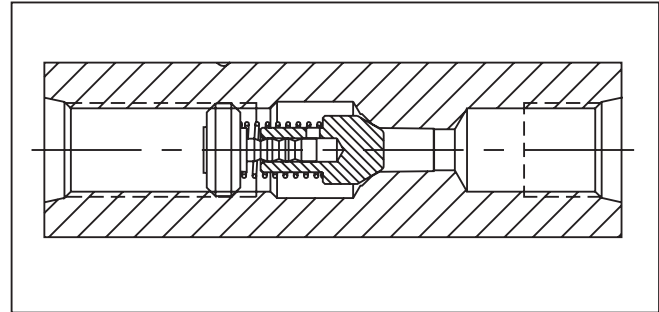
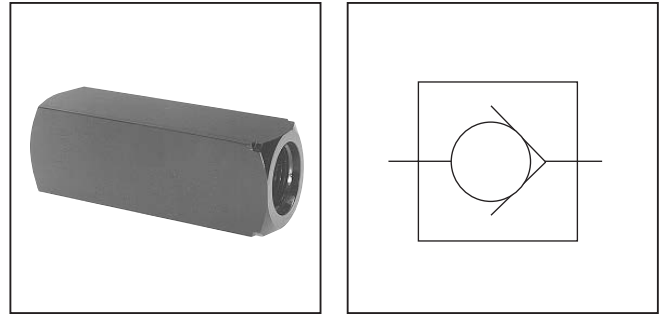

Specifications

Maximum Operating Pressure	345 Bar (5000 PSI)	
Maximum Flow	M16 x 1.5	19 LPM (5 GPM)
	M18 x 1.5	30 LPM (8 GPM)
	M22 x 1.5	57 LPM (15 GPM)
	M27 x 2.0	95 LPM (25 GPM)
	M33 x 2.0	151 LPM (40 GPM)
	M42 x 2.0	265 LPM (70 GPM)
	M48 x 2.0	379 LPM (100 GPM)
Cracking Pressure	Standard: 0.3 Bar (5 PSI) Optional: 4.5 Bar (65 PSI)	
Material	Body	ASTM 12L14 Carbon Steel
	Poppet	ASTM 416 Stainless Steel
	Retainer	ASTM 416 Stainless Steel
	Spring	ASTM 316 Stainless Steel
Temperature Range of Seal Compound	-40°C to +121°C (-40°F to +250°F) Nitrile (Standard) -26°C to +205°C (-15°F to +400°F) Fluorocarbon	

Performance Curves

Controlled Flow vs. Pressure Drop

Free Flow 0.3 Bar (5 PSI) Cracking
 100 SSU, Hydraulic Oil

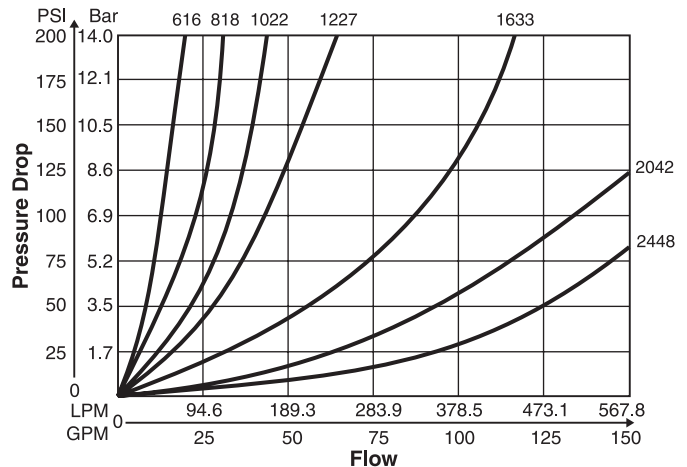

Ordering Information

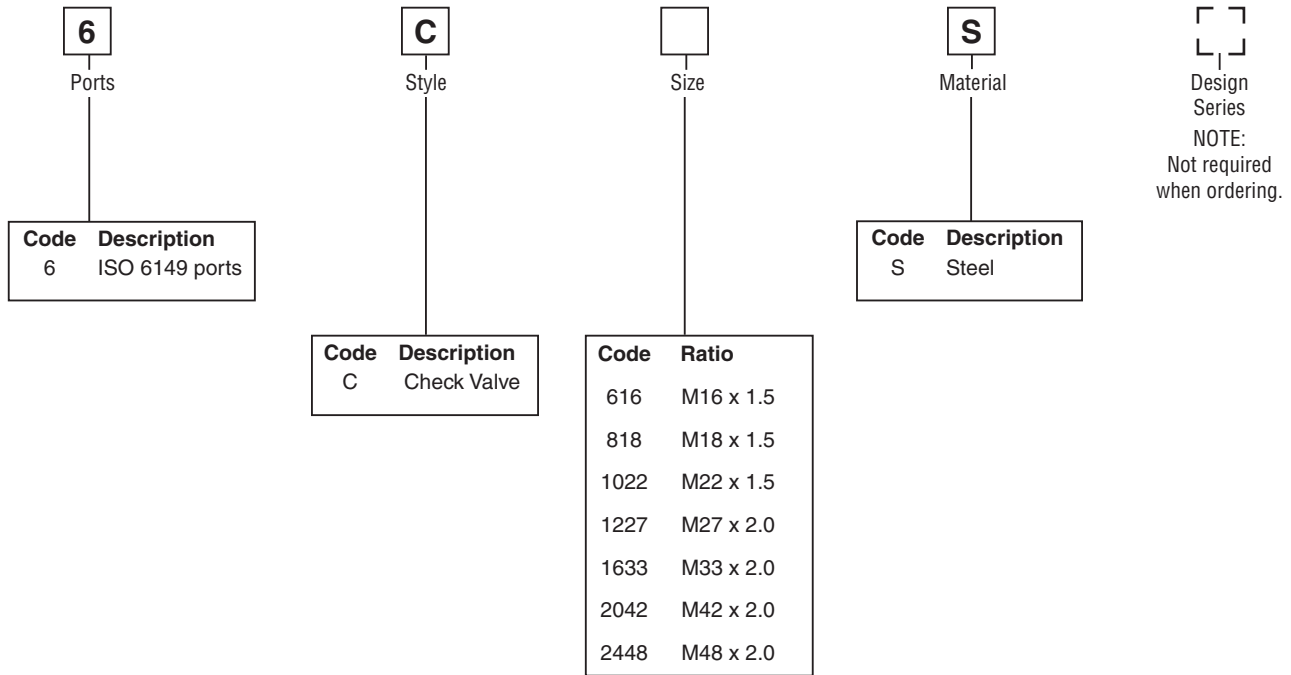

Dimensions

Inch equivalents for millimeter dimensions are shown in (**)

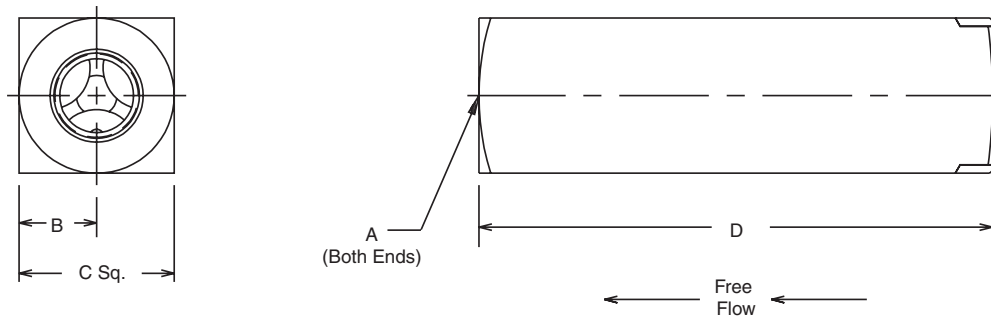

Model Number	Weight kg (lbs.)	A	B	C	D
6C616	0.2 (0.5)	M16 x 1.5	12.7 (0.50)	25.4 (1.00)	79.2 (3.12)
6C818	0.3 (0.7)	M18 x 1.5	14.2 (0.56)	28.4 (1.12)	88.9 (3.50)
6C1022	0.6 (1.3)	M22 x 1.5	15.7 (0.62)	31.8 (1.25)	101.6 (4.00)
6C1227	0.9 (2.0)	M27 x 2.0	19.1 (0.75)	38.1 (1.50)	117.3 (4.62)
6C1633	1.5 (3.3)	M33 x 2.0	22.4 (0.88)	44.5 (1.75)	127.0 (5.00)
6C2042	2.8 (6.2)	M42 x 2.0	28.7 (1.13)	57.2 (2.25)	132.8 (5.23)
6C2448	3.8 (8.4)	M48 x 2.0	35.1 (1.38)	69.9 (2.75)	143.0 (5.63)

General Description

Series VCL check valves operate at free flow in one direction. Reverse flow is blocked.

Operation

The spring keeps the poppet closed until the valve reaches the preset pressure. The valve stays open until the pressure goes below the spring setting.

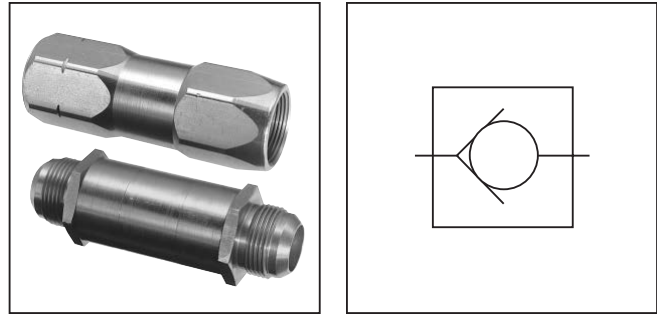

Features

- Poppet spring is isolated from liquid flow stream minimizing turbulence.
- Close tolerance fit between poppet and poppet retainer creates a cushion that protects valve from surge shock damage.

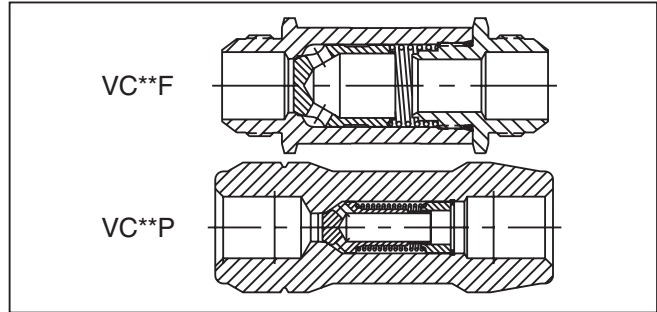

Specifications

Models VCL*P (female pipe to female pipe)

Valve Model	Max. Oper. Press. Bar (PSI)	Material	Rated Flow LPM (GPM)	Cracking Press. ΔP Bar (PSI)	Total ΔP Bar (PSI)	Port Size
VCL4P05 VCL4P65	207 (3000) 207 (3000)	Steel† Steel†	23 (5) 23 (5)	0.3 (5) 4.5 (65)	0.6 (8.3) 5.0 (72.5)	1/4 NPSF 1/4 NPSF
VCL6P05 VCL6P65	207 (3000) 207 (3000)	Steel† Steel†	30 (8) 30 (8)	0.3 (5) 4.5 (65)	0.4 (6.0) 4.6 (66.0)	3/8 NPSF 3/8 NPSF
VCL8P05 VCL8P65	207 (3000) 207 (3000)	Steel† Steel†	45 (15) 45 (15)	0.3 (5) 4.5 (65)	0.5 (7.2) 4.6 (66.0)	1/2 NPSF 1/2 NPSF
VCL12P05 VCL12P65	207 (3000) 207 (3000)	Steel† Steel†	100 (25) 100 (25)	0.3 (5) 4.5 (65)	0.8 (11.0) 4.6 (67.0)	3/4 NPSF 3/4 NPSF
VCL16P05 VCL16P65	207 (3000) 207 (3000)	Steel† Steel†	133 (35) 133 (35)	0.3 (5) 4.5 (65)	0.4 (5.3) 4.6 (66.0)	1 NPSF 1 NPSF
VCL20P05 VCL20P65	207 (3000) 207 (3000)	Steel† Steel†	189 (50) 189 (50)	0.3 (5) 4.5 (65)	1.1 (15.9) 5.4 (78.0)	1-1/4 NPSF 1-1/4 NPSF

† All steel construction with zinc chromate plating.

Models VCL*F (male 37° flare to male 37°)

Valve Model	Max. Oper. Press. Bar (PSI)	Material	Standard Seals	Rated Flow LPM (GPM)	Cracking Press. ΔP Bar (PSI)	Total ΔP Bar (PSI)	Port Size
VCL6F05 VCL6F65	207 (3000) 207 (3000)	Steel† Steel†	Nitrile O-Rings Nitrile O-Rings	23 (5) 23 (5)	0.3 (5) 4.5 (65)	0.6 (8.3) 5.0 (72.5)	9/16-18 UNF (SAE 6)
VCL8F05 VCL8F65	207 (3000) 207 (3000)	Steel† Steel†	Nitrile O-Rings Nitrile O-Rings	30 (8) 30 (8)	0.3 (5) 4.5 (65)	0.4 (6.0) 4.6 (66.0)	3/4-16 UNF (SAE 8)
VCL10F05 VCL10F65	207 (3000) 207 (3000)	Steel† Steel†	Nitrile O-Rings Nitrile O-Rings	45 (15) 45 (15)	0.3 (5) 4.5 (65)	0.5 (7.2) 4.6 (66.0)	7/8-14 UNF (SAE 10)
VCL12F05 VCL12F65	207 (3000) 207 (3000)	Steel† Steel†	Nitrile O-Rings Nitrile O-Rings	100 (25) 100 (25)	0.3 (5) 4.5 (65)	0.8 (11.0) 4.6 (67.0)	1 1/16-12 UN (SAE 12)
VCL16F05 VCL16F65	207 (3000) 207 (3000)	Steel† Steel†	Nitrile O-Rings Nitrile O-Rings	133 (35) 133 (35)	0.3 (5) 4.5 (65)	0.4 (5.3) 4.6 (66.0)	1 5/16-12 UN (SAE 16)
VCL20F05 VCL20F65	207 (3000) 207 (3000)	Steel† Steel†	Nitrile O-Rings Nitrile O-Rings	189 (50) 189 (50)	0.3 (5) 4.5 (65)	1.1 (15.9) 5.4 (78.0)	1 5/8-12 UN (SAE 20)

† All steel construction with zinc chromate plating.

VCL
 Series VCL

Size

Code	Description
4*	1/4"
6	3/8"
8	1/2"
10†	5/8"
12	3/4"
16	1"
20	1 1/4"

* 37° flare (F) not available in size 4.

† NPSF (P) not available in size 10.

Port Style

Code	Description
F	37° Flare Tube Both Ends
P	NPSF Female Both Ends

Cracking Pressure

Code	Description
05	0.3 Bar (5 PSI)
65	4.5 Bar (65 PSI)

A

Seal Compound

Code	Description
Omit	Nitrile (Standard)
V *	Fluorocarbon

* Only available with "F" port style.

Design Series

NOTE:
 Not required when ordering.

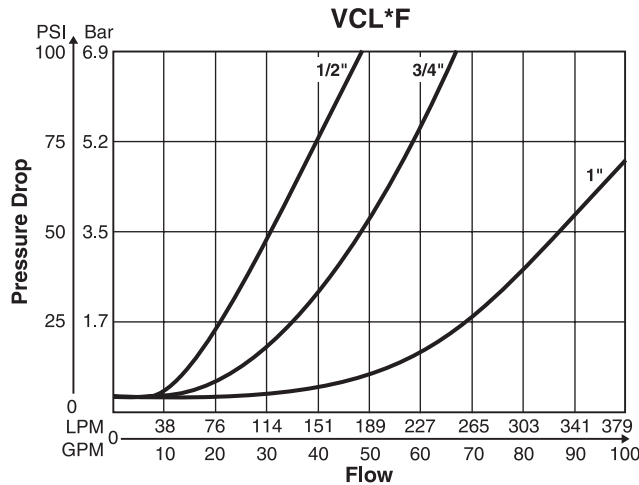
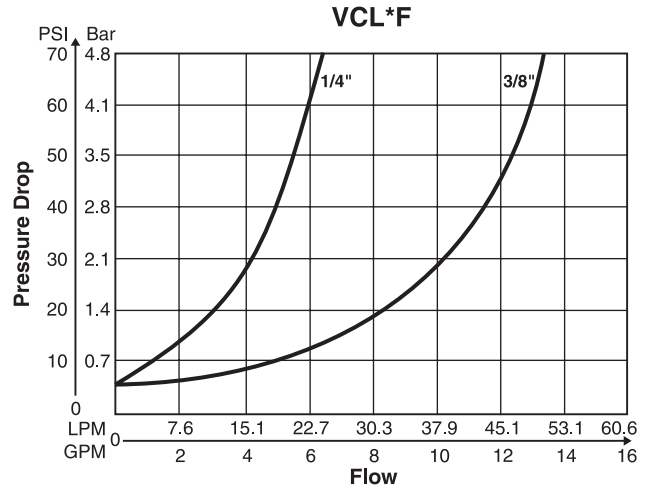
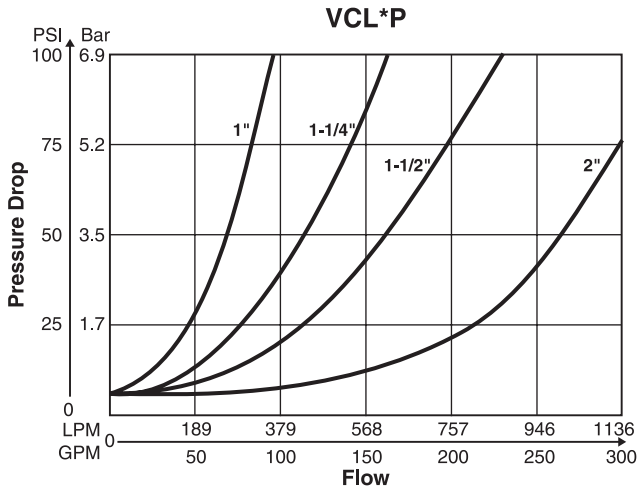
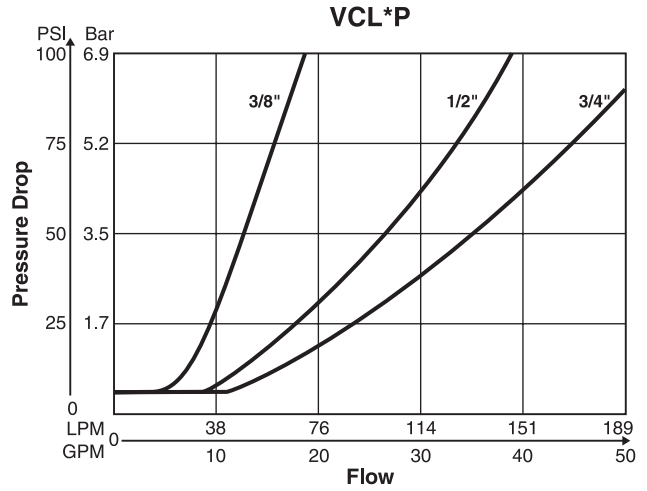
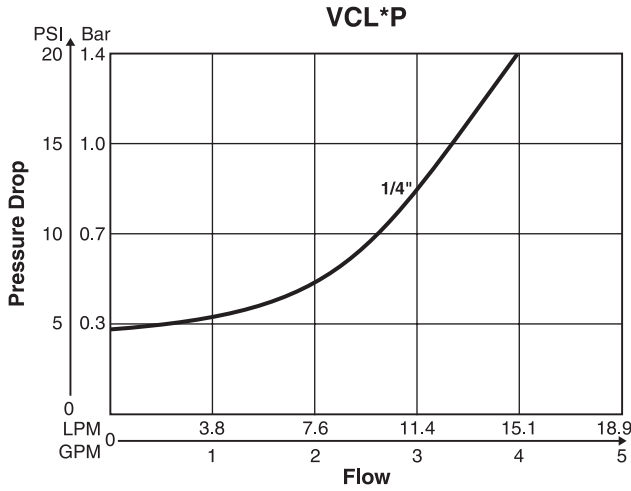

Inch equivalents for millimeter dimensions are shown in (**)

Models VCL*P

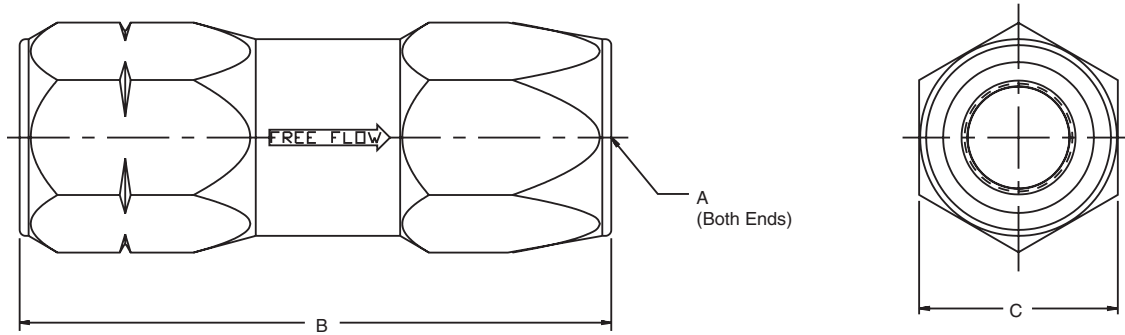

Model Code	Weight kg (lbs.)	A	B	C
VCL4P**A	0.2 (0.4)	1/4-1/8 NPSF	62.0 (2.44)	20.6 (0.81)
VCL6P**A	0.3 (0.7)	3/8-18 NPSF	69.9 (2.75)	22.4 (0.88)
VCL8P**A	0.4 (0.9)	1/2-14 NPSF	88.9 (3.50)	26.9 (1.06)
VCL12P**A	0.5 (1.2)	3/4-14 NPSF	98.6 (3.88)	34.8 (1.37)
VCL16P**A	0.8 (1.8)	1-11 1/2 NPSF	124.0 (4.88)	40.6 (1.60)
VCL20P**A	2.0 (4.3)	1 1/4-11 1/2 NPSF	125.0 (4.94)	50.8 (2.00)

Models VCL*F

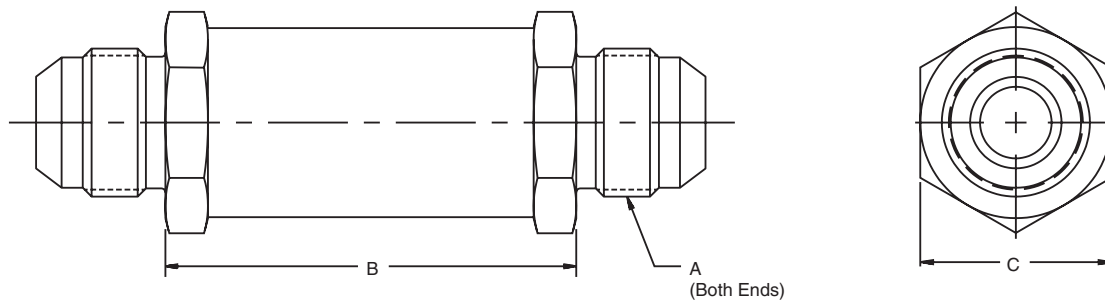

Model Code	Weight kg (lbs.)	A	B	C
VCL6F**A	0.2 (0.4)	9/16-18 UNF (SAE 6)	44.5 (1.75)	20.6 (0.81)
VCL8F**A	0.3 (0.7)	3/4-16 UNF (SAE 8)	56.4 (2.22)	25.4 (1.00)
VCL10F**A	0.4 (0.9)	7/8-14 UNF (SAE 10)	61.2 (2.41)	28.4 (1.12)
VCL12F**A	0.5 (1.2)	1 1/16-12 UN (SAE 12)	69.9 (2.75)	35.1 (1.38)
VCL16F**A	0.8 (1.8)	1 15/16-12 UN (SAE 16)	84.1 (3.31)	44.1 (1.62)
VCL20F**A	2.0 (4.3)	1 5/8-12 UN (SAE 20)	84.1 (3.31)	47.8 (1.88)



General Description

Series GF valves isolate gages from damage and inaccurate readings caused by line pressure surges and hydraulic hammer.

Operation

The GF uses a capillary orifice to smooth out line pulsations and surges without the use of any moving parts.

Features

- One piece construction.
- The GF requires no adjustment or maintenance.

Specifications

Maximum Operating Pressure	207 Bar (3000 PSI)
-----------------------------------	--------------------

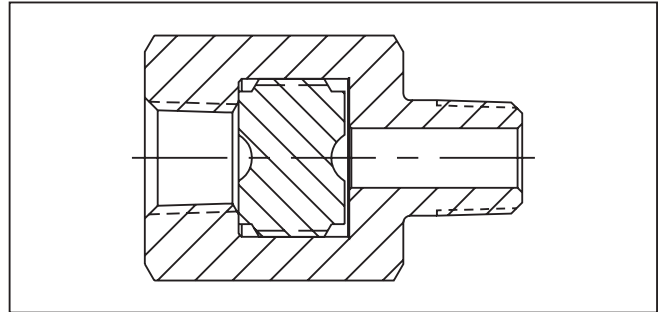
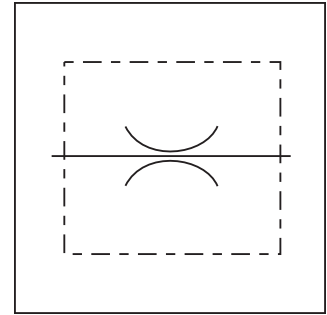
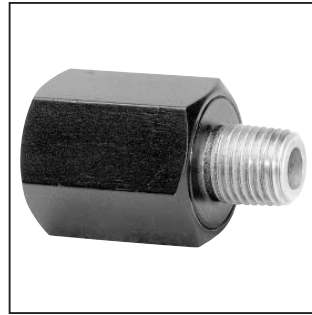

Ordering Information

Options

Code	Description
Omit	NPTF/SAE
★9	BSP

Series **GF**

Size

Code	Description
400	1/4"
420	7/16 - 20 UNF (SAE 4)

Material **S**

Code	Description
S	Steel

Design Series

NOTE:
 Not required when ordering.

★ Code 9 can be used with size 400

Weight: 0.6 kg (1.3 lbs.)

Dimensions

Inch equivalents for millimeter dimensions are shown in (**)

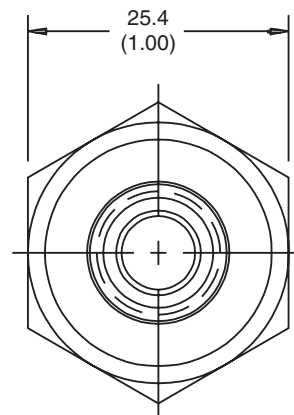
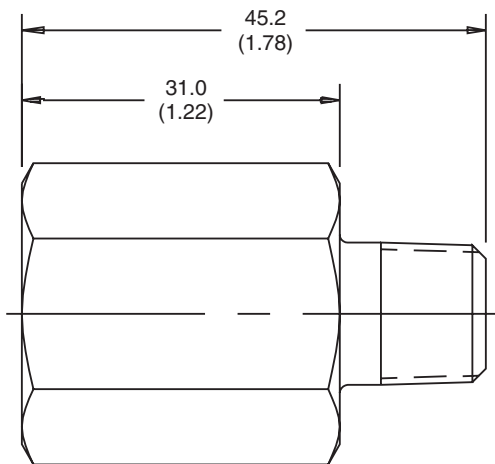

General Description

Series GT valves isolate gauges from damage and inaccurate readings caused by line pressure surges and hydraulic hammer.

Operation

The GT has a push-to-read knob that delivers instant pressure to the gauge, yet isolates the gauge from the fluid line until the knob is pressed. When the knob is released, a spring-loaded spool closes instantly and drains all fluid from the gauge back into the reservoir.

Features

- Has a hardened steel spool.
- Partial snubbing action protects the gauge from surge damage.
- Optional panel mount.

Specifications

Maximum Operating Pressure	207 Bar (3000 PSI)
Mounting	In-line

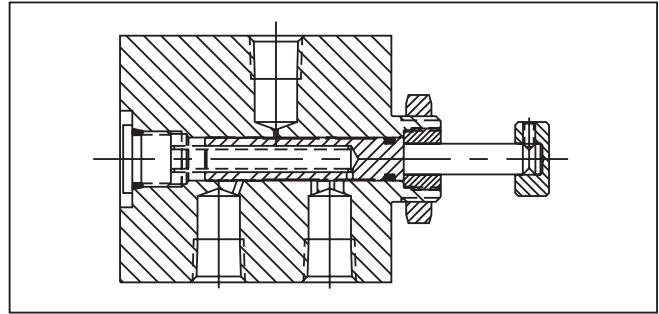
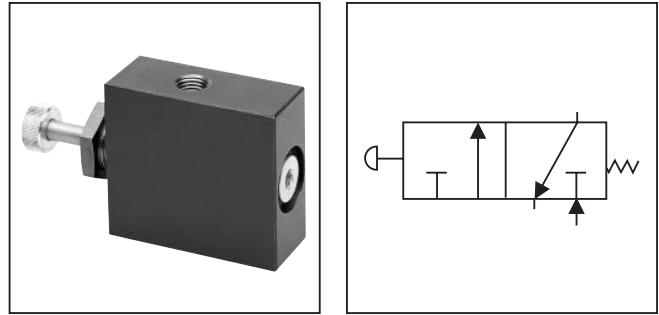

Ordering Information

□ Options	GT Series GT	□ Size												
<table border="1"> <thead> <tr> <th>Code</th> <th>Description</th> </tr> </thead> <tbody> <tr> <td>Omit</td> <td>NPTF/SAE</td> </tr> <tr> <td>★9</td> <td>BSP</td> </tr> </tbody> </table>	Code	Description	Omit	NPTF/SAE	★9	BSP	<table border="1"> <thead> <tr> <th>Code</th> <th>Description</th> </tr> </thead> <tbody> <tr> <td>400</td> <td>1/4"</td> </tr> <tr> <td>420</td> <td>7/16-20 UNF (SAE 4)</td> </tr> </tbody> </table>	Code	Description	400	1/4"	420	7/16-20 UNF (SAE 4)	
Code	Description													
Omit	NPTF/SAE													
★9	BSP													
Code	Description													
400	1/4"													
420	7/16-20 UNF (SAE 4)													

★ Code 9 can be used with size 400

S Material	□ Seal Compound	□ Design Series										
<table border="1"> <thead> <tr> <th>Code</th> <th>Description</th> </tr> </thead> <tbody> <tr> <td>S</td> <td>Steel</td> </tr> </tbody> </table>	Code	Description	S	Steel	<table border="1"> <thead> <tr> <th>Code</th> <th>Description</th> </tr> </thead> <tbody> <tr> <td>Omit</td> <td>Nitrile (Std.)</td> </tr> <tr> <td>V</td> <td>Fluorocarbon</td> </tr> </tbody> </table>	Code	Description	Omit	Nitrile (Std.)	V	Fluorocarbon	<p>NOTE: Not required when ordering.</p>
Code	Description											
S	Steel											
Code	Description											
Omit	Nitrile (Std.)											
V	Fluorocarbon											

Weight: 1.0 kg (2.2 lbs.)

Dimensions

Inch equivalents for millimeter dimensions are shown in (**)

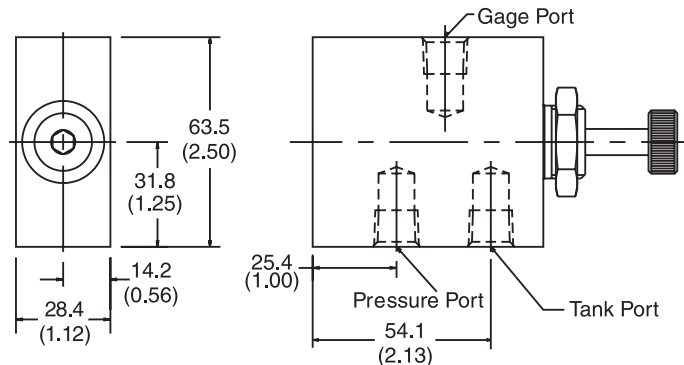
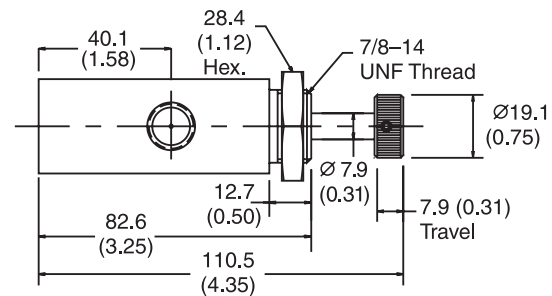



High Pressure Valves
Low Pressure Valves

Ball Valves



ENGINEERING YOUR SUCCESS.

General Description

Series BVHP, BVAH, BVHS are 2-way shut-off valves rated at 207 Bar (3000 PSI) and 414 Bar (6000 PSI). A variety of porting options from 1/4" to 2" are available including threaded, SAE 4-bolt flange and split flange.

Operation

Parker's 2-way ball valves operate to either off or full flow by rotating the handle 90°. Ball valves are not designed to be a metering or flow control device.

Specifications

Maximum Pressure	BVHP, BVAH steel: 414 Bar (6000 PSI) BVHP16, BVAH stainless steel: 207 Bar (3000 PSI) BVHP04-12, BVHS stainless steel: 414 Bar (6000 PSI)
Body Material	Carbon Steel, Black Oxide Stainless Steel
Ball Material	Steel, Chrome Plated Stainless Steel
Stem Material	Steel, Zinc Plated Stainless Steel
Standard Handle	Steel Offset, Nickel Plated
Standard Ball Seals	Delrin + MoS ₂
Standard Shaft Seals	O-Ring & Backup, Nitrile
Temperature Range with Standard Seals	-30°C to +100°C (-22°F to +212°F)

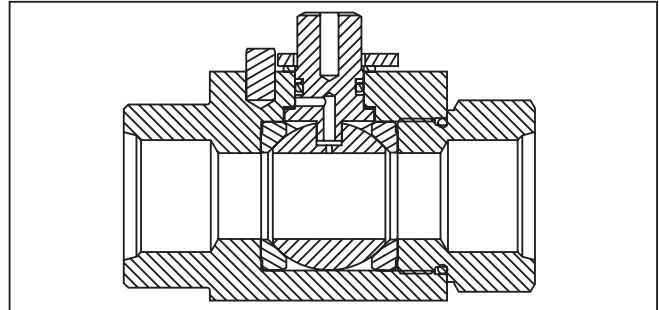
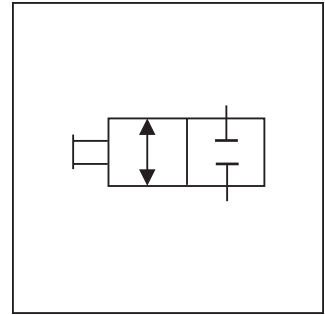

Features

- Thrust bearings and synthetic lubrication in the spindle results in one of the lowest torque requirements in the industry.
- A wide variety of porting options and mounting options make the BVHP, BVAH, BVHS suitable for all mounting applications.
- Delrin seals with molybdenum disulphide (MoS₂) results in lower actuation torque and will increase high duty life cycle expectancy.
- The variety of spindle and ball sealing options makes the BVHP, BVAH, BVHS suitable for most media applications.
- Limit switch (LSB) is NEMA 4 with CSA/UL approval.

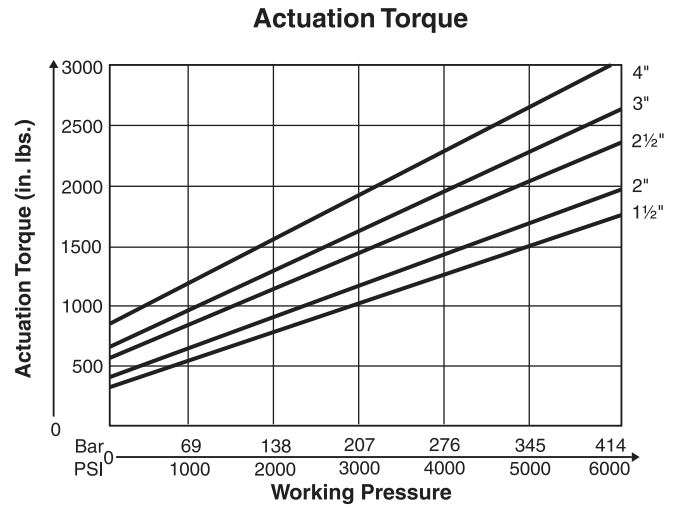
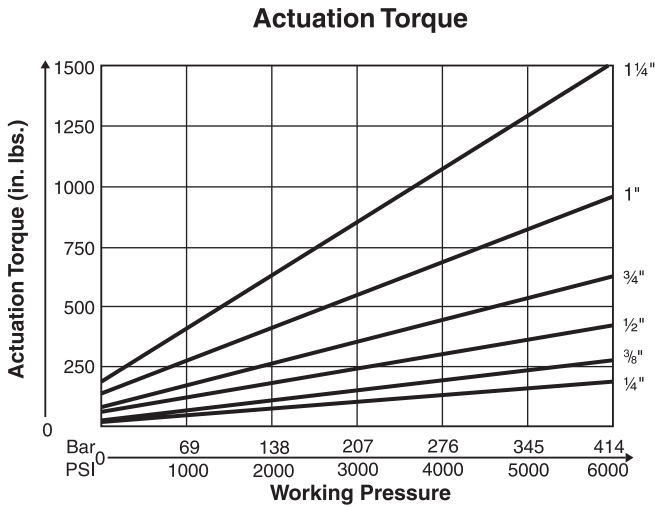
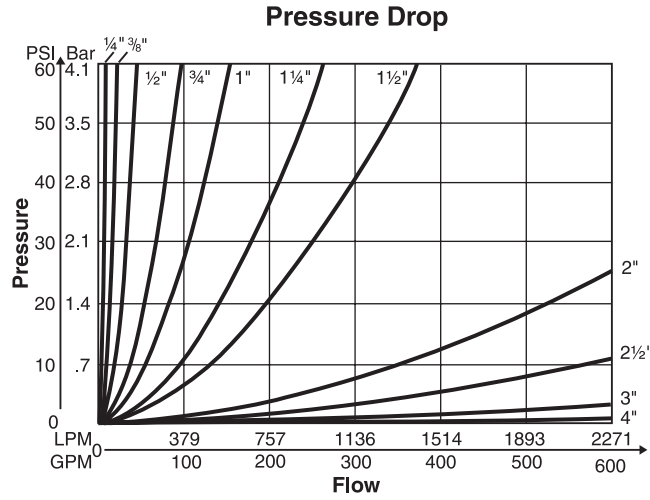

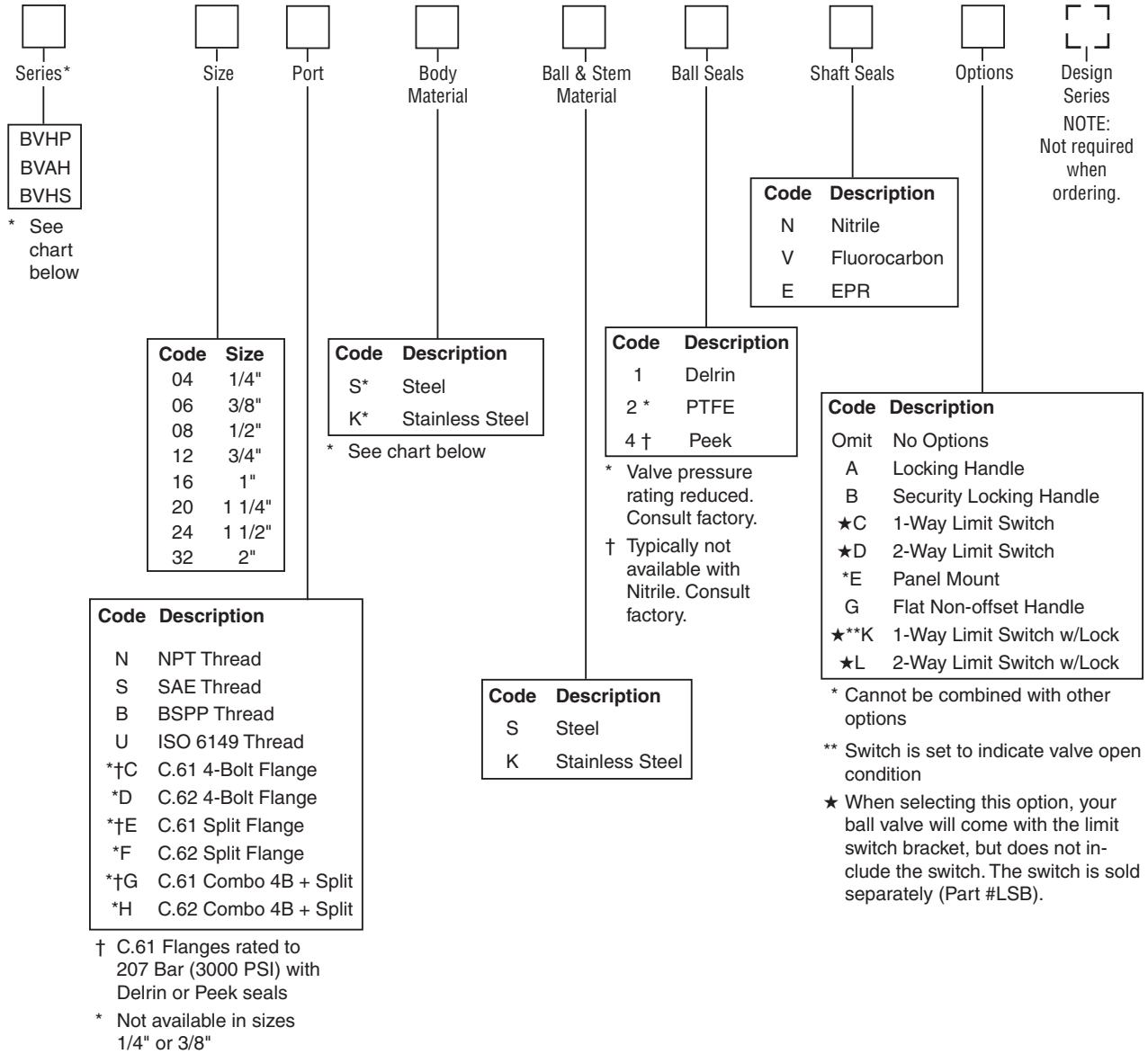

ISO 6149-1 Port Dimensions (inches)

Size	Thread
04	M12 x 1.5
06	M16 x 1.5
08	M18 x 1.5
12	M27 x 2
16	M33 x 2
20	M42 x 2
24	M48 x 2
32	M60 x 2

Weights

Code	Threaded kg (lbs.)	C. 61, 3000 PSI kg (lbs.)	C. 62, 6000 PSI kg (lbs.)
04	0.6 (1.25)	—	—
06	0.7 (1.5)	—	—
08	0.8 (1.75)	0.9 (2.0)	1.3 (2.75)
12	1.9 (4.25)	2.2 (4.75)	2.5 (5.5)
16	2.5 (5.5)	3.2 (7.0)	3.9 (8.5)
20	4.2 (9.25)	5.9 (13.0)	6.8 (15.0)
24	5.2 (11.5)	7.1 (15.7)	8.6 (19.0)
32	8.4 (18.5)	11.8 (24.25)	13.6 (30.0)

	4	6	8	12	16	20	24	32
Steel - 414 Bar (6000 PSI)	BVHP	BVHP	BVHP	BVHP	BVHP	BVAH	BVAH	BVAH
Stainless Steel - 207 Bar (3000 PSI)	X	X	X	X	BVHP	BVAH	BVAH	BVAH
Stainless Steel - 414 Bar (6000 PSI)	BVHP	BVHP	BVHP	BVHP	BVHS	BVHS	BVHS	BVHS

Threaded Ports – BVHP

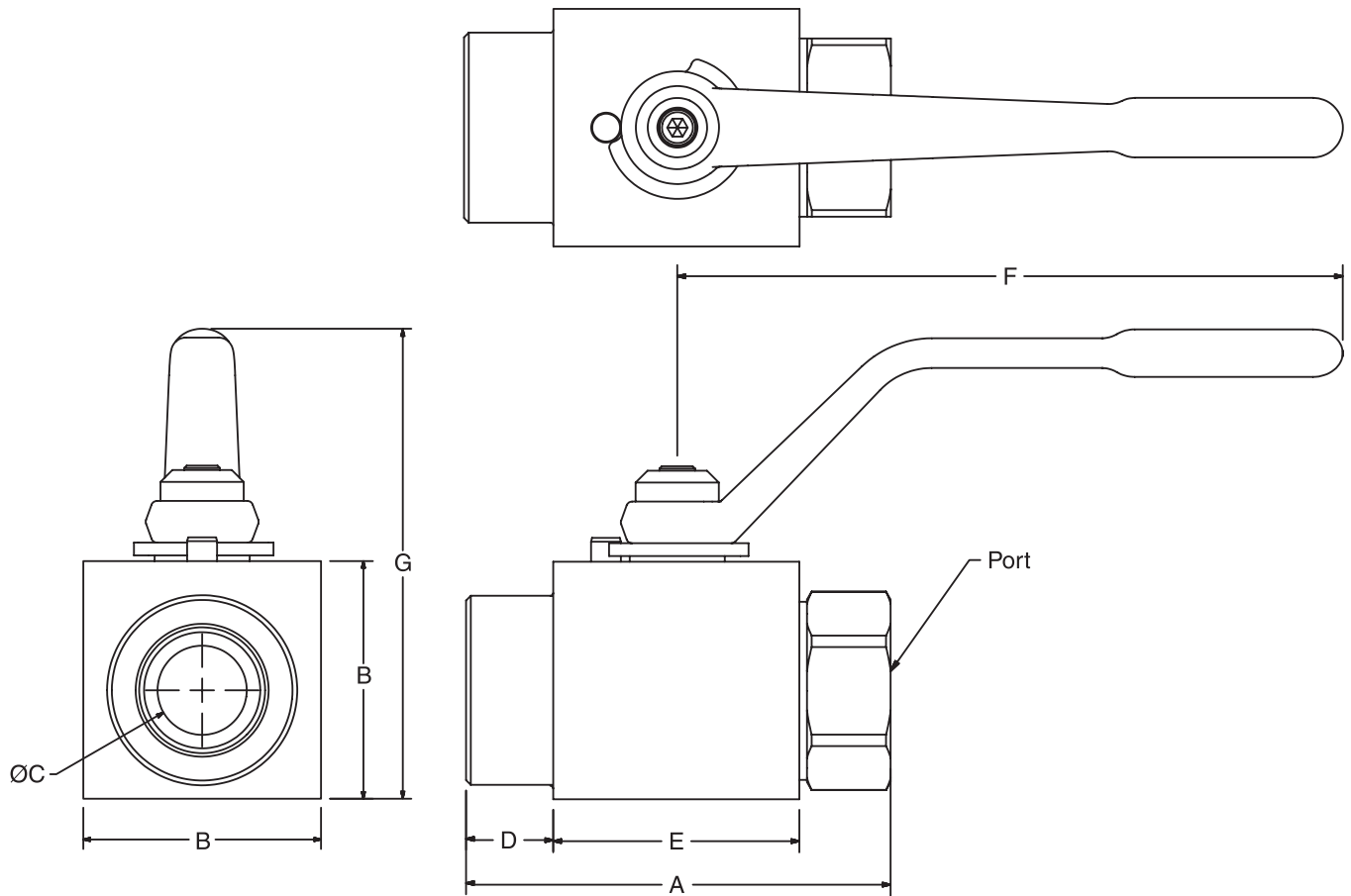

Code	Port Thread Size	Working Pressure*	Dimensions mm (in)						
			A	B	C	D	E	F	G
BVHP – NPT, SAE, and BSPP									
04	1/4"	414 Bar (6000 PSI)	69.6 (2.74)	35.1 (1.38)	7.9 (0.31)	16.7 (0.66)	35.7 (1.40)	114.3 (4.50)	75.9 (2.99)
06	3/8"	414 Bar (6000 PSI)	72.9 (2.87)	38.1 (1.50)	9.7 (0.38)	14.9 (0.59)	42.4 (1.67)	114.3 (4.50)	79.2 (3.12)
08	1/2"	414 Bar (6000 PSI)	85.3 (3.36)	41.4 (1.63)	12.7 (0.50)	18.5 (0.73)	47.5 (1.87)	114.3 (4.50)	82.6 (3.25)
12	3/4"	414 Bar (6000 PSI)	96.8 (3.81)	57.2 (2.25)	19.1 (0.75)	17.2 (0.68)	61.5 (2.42)	177.8 (7.00)	120.1 (4.73)
16	1"	414 Bar (6000 PSI)	114.6 (4.51)	63.5 (2.50)	23.9 (0.94)	23.9 (0.94)	65.8 (2.59)	177.8 (7.00)	126.5 (4.98)

* BVHP16 in stainless steel is rated to 207 Bar (3000 PSI).

Threaded Ports – BVAH, BVHS

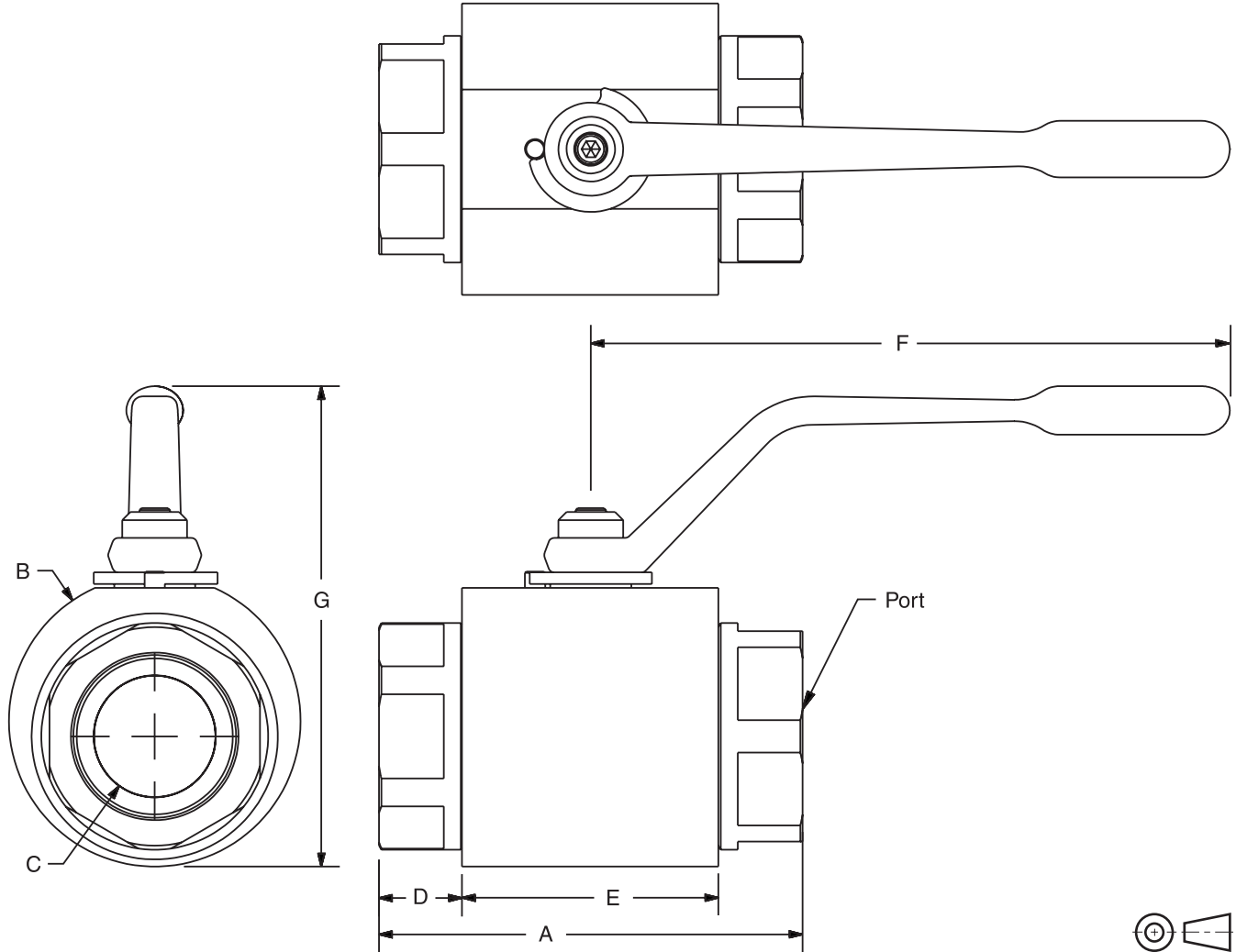

Code	Port Thread Size	Working Pressure*	Dimensions mm (in)						
			A	B	C	D	E	F	G
BVAH – NPT, SAE, and BSPP									
20	1 1/4"	414 Bar (6000 PSI)	122.9 (4.84)	85.9 (3.38)	31.8 (1.25)	21.0 (0.83)	80.5 (3.17)	250.2 (9.85)	163.8 (6.45)
24	1 1/2"	414 Bar (6000 PSI)	135.4 (5.33)	95.3 (3.75)	38.1 (1.50)	24.7 (0.97)	85.5 (3.37)	250.2 (9.85)	173.2 (6.82)
32	2"	414 Bar (6000 PSI)	166.1 (6.54)	114.3 (4.50)	47.8 (1.88)	32.5 (1.28)	100.5 (3.96)	250.2 (9.85)	190.2 (7.49)
BVHS – NPT, SAE, and BSPP									
16	1"	414 Bar (6000 PSI)	123.2 (4.85)	79.5 (3.13)	22.4 (0.88)	12.7 (0.50)	97.3 (3.83)	177.8 (7.00)	132.2 (5.40)
20	1 1/4"	414 Bar (6000 PSI)	123.2 (4.85)	101.6 (4.00)	28.7 (1.13)	12.7 (0.50)	97.3 (3.83)	250.2 (9.85)	177.8 (7.00)
24	1 1/2"	414 Bar (6000 PSI)	138.7 (5.46)	108.0 (4.25)	33.3 (1.31)	16.8 (0.66)	104.5 (4.12)	250.2 (9.85)	186.4 (7.34)
32	2"	414 Bar (6000 PSI)	166.1 (6.54)	127.0 (5.00)	44.5 (1.75)	19.6 (0.77)	126.4 (4.98)	250.2 (9.85)	202.9 (7.99)

* BVAH in stainless steel is rated to 207 Bar (3000 PSI).

SAE 4-Bolt Flange – BVHP

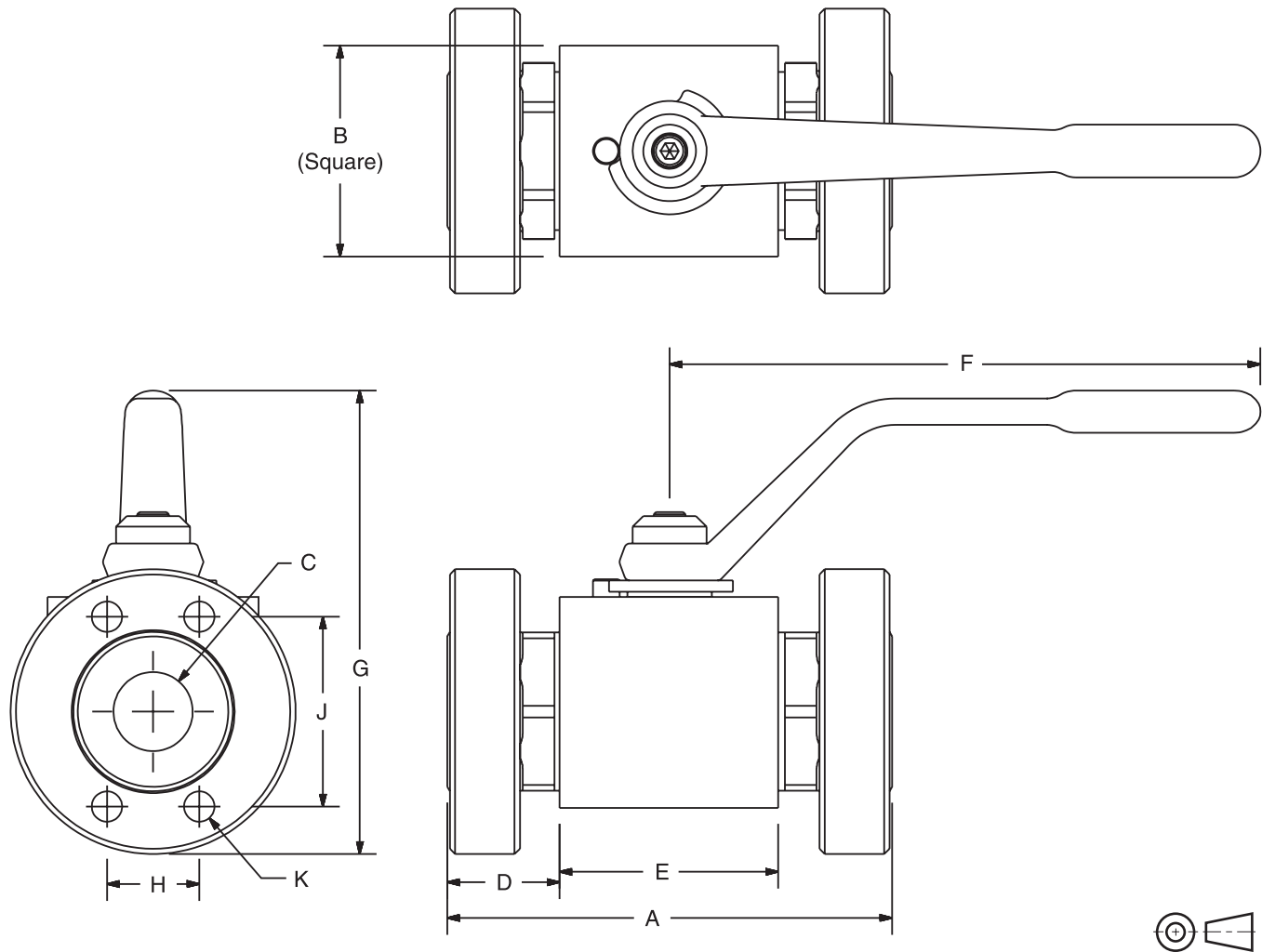

Code	SAE 4-B Flange Size	Working Pressure*	Dimensions mm (in)									
			A	B	C	D	E	F	G	H	J	K
BVHP – C.61 – SAE 4-Bolt Flange												
08	1/2"	207 Bar (3000 PSI)	108.2 (4.26)	41.4 (1.63)	12.7 (0.50)	30.4 (1.20)	47.5 (1.87)	114.3 (4.50)	91.0 (3.58)	17.5 (0.69)	38.1 (1.50)	5/16"-18
12	3/4"	207 Bar (3000 PSI)	121.2 (4.77)	57.2 (2.25)	19.1 (0.75)	29.8 (1.18)	61.5 (2.42)	177.8 (7.00)	128.9 (5.08)	22.4 (0.88)	47.8 (1.88)	3/8"-16
16	1"	207 Bar (3000 PSI)	133.9 (5.27)	63.5 (2.50)	23.9 (0.94)	34.0 (1.34)	65.8 (2.59)	177.8 (7.00)	135.4 (5.33)	26.2 (1.03)	52.3 (2.06)	3/8"-16
BVHP – C.62 – SAE 4-Bolt Flange												
08	1/2"	414 Bar (6000 PSI)	108.2 (4.26)	41.4 (1.63)	12.7 (0.50)	30.4 (1.20)	47.5 (1.87)	114.3 (4.50)	92.6 (3.65)	18.3 (0.72)	40.4 (1.59)	5/16"-18
12	3/4"	414 Bar (6000 PSI)	121.2 (4.77)	57.2 (2.25)	19.1 (0.75)	29.8 (1.18)	61.5 (2.42)	177.8 (7.00)	129.8 (5.11)	23.9 (0.94)	50.8 (2.00)	3/8"-16
16	1"	414 Bar (6000 PSI)	133.9 (5.27)	63.5 (2.50)	23.9 (0.94)	34.0 (1.34)	65.8 (2.59)	177.8 (7.00)	140.3 (5.52)	27.7 (1.09)	57.2 (2.25)	7/16"-14

* BVHP16 in stainless steel is rated to 207 Bar (3000 PSI).

SAE 4-Bolt Flange – BVAH

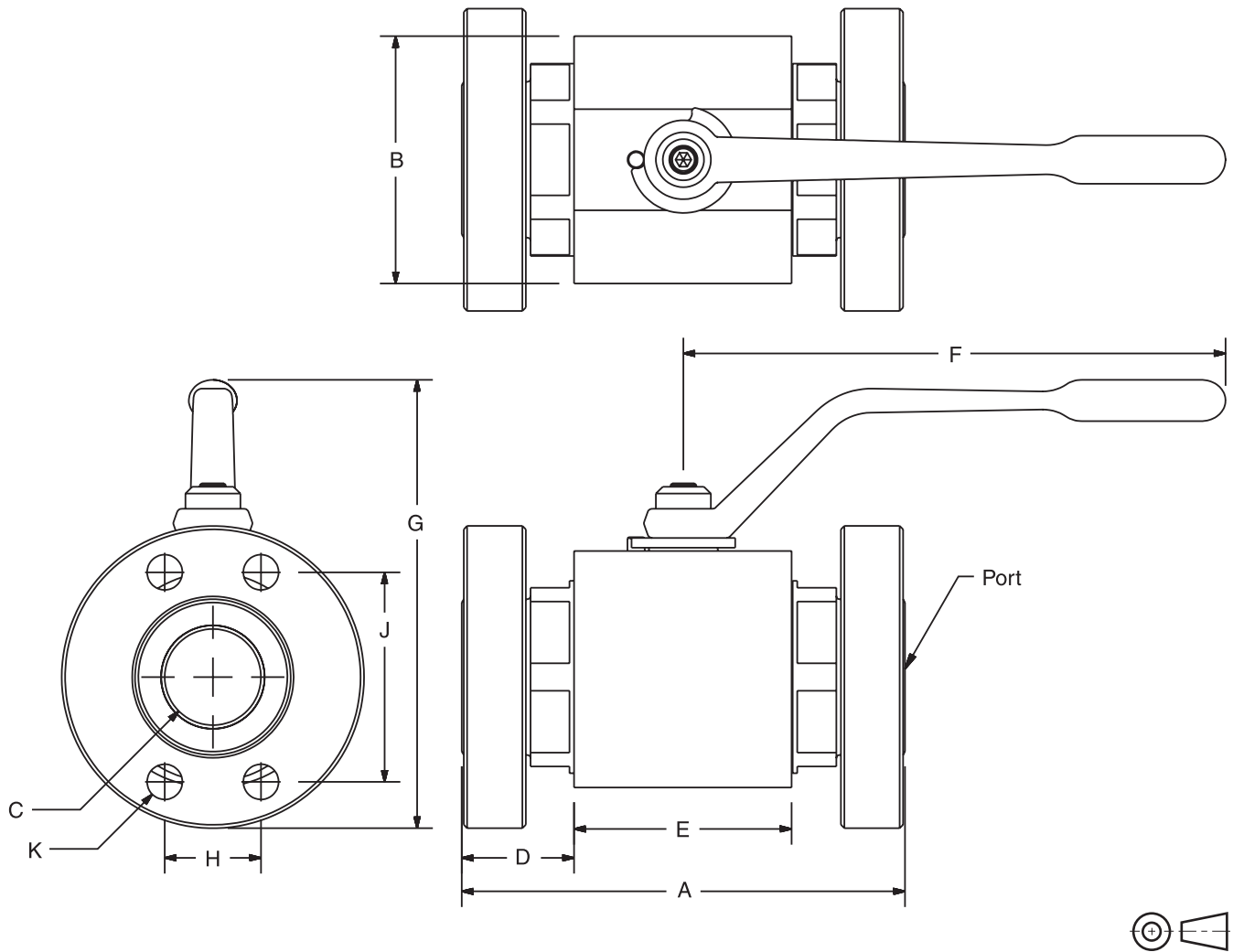

Code	SAE 4-B Flange Size	Working Pressure*	Dimensions mm (in)									
			A	B	C	D	E	F	G	H	J	K
BVAH – C.61 – SAE 4-Bolt Flange												
20	1 1/4"	207 Bar (3000 PSI)	175.3 (6.90)	85.9 (3.38)	31.8 (1.25)	47.1 (1.86)	80.5 (3.17)	250.2 (9.85)	170.0 (6.69)	30.2 (1.19)	58.7 (2.31)	7/16"-14
24	1 1/2"	207 Bar (3000 PSI)	180.1 (7.09)	95.3 (3.75)	38.1 (1.50)	47.0 (1.85)	85.5 (3.37)	250.2 (9.85)	179.7 (7.07)	35.8 (1.41)	69.9 (2.75)	1/2"-13
32	2"	207 Bar (3000 PSI)	204.7 (8.06)	114.3 (4.50)	47.8 (1.88)	51.8 (2.04)	100.5 (3.96)	250.2 (9.85)	196.6 (7.74)	42.9 (1.69)	77.7 (3.06)	1/2"-13
BVAH – C.62 – SAE 4-Bolt Flange												
20	1 1/4"	414 Bar (6000 PSI)	175.3 (6.90)	85.9 (3.38)	31.8 (1.25)	47.1 (1.86)	80.5 (3.17)	250.2 (9.85)	174.8 (6.88)	31.8 (1.25)	66.8 (2.63)	1/2"-13
24	1 1/2"	414 Bar (6000 PSI)	180.1 (7.09)	95.3 (3.75)	38.1 (1.50)	47.0 (1.85)	85.5 (3.37)	250.2 (9.85)	189.2 (7.45)	36.6 (1.44)	79.2 (3.12)	5/8"-11
32	2"	414 Bar (6000 PSI)	204.7 (8.06)	114.3 (4.50)	47.8 (1.88)	51.8 (2.04)	100.5 (3.96)	250.2 (9.85)	209.3 (8.24)	44.5 (1.75)	96.8 (3.81)	3/4"-10

* BVAH in stainless steel is rated to 207 Bar (3000 PSI).

SAE 4-Bolt Flange – BVHS

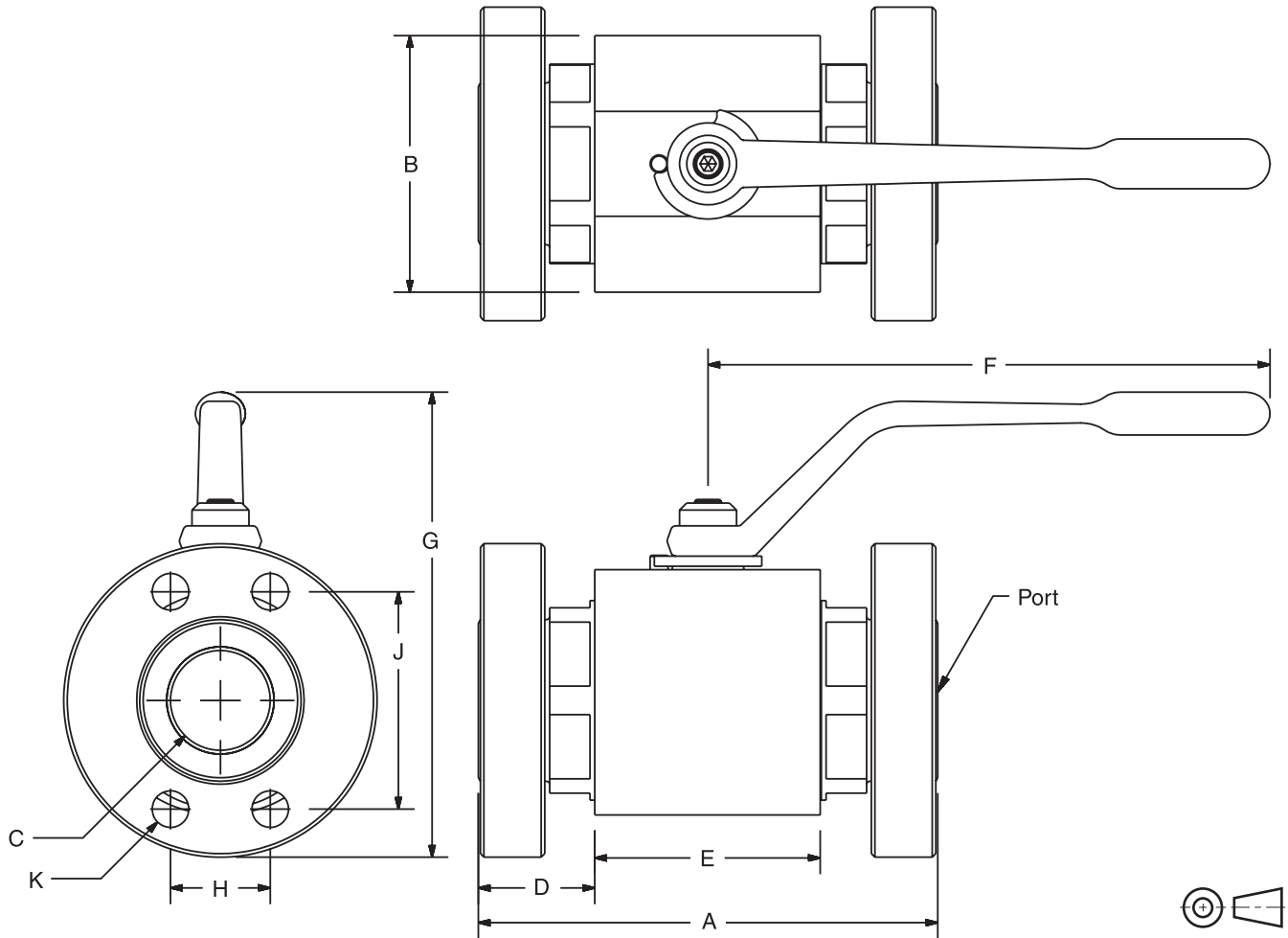

Code	SAE 4-B Flange Size	Working Pressure	Dimensions mm (in)									
			A	B	C	D	E	F	G	H	J	K
BVHS – C.61 – SAE 4-Bolt Flange												
16	1"	207 Bar (3000 PSI)	134.1 (5.28)	79.5 (3.13)	22.4 (0.88)	18.2 (0.72)	97.3 (3.83)	177.8 (7.00)	137.2 (5.40)	26.2 (1.03)	52.3 (2.06)	3/8"-16
20	1 1/4"	207 Bar (3000 PSI)	175.3 (6.90)	101.6 (4.00)	28.7 (1.13)	38.7 (1.53)	97.3 (3.83)	250.2 (9.85)	177.8 (7.00)	30.1 (1.19)	58.7 (2.31)	7/16"-14
24	1 1/2"	207 Bar (3000 PSI)	180.1 (7.09)	108.0 (4.25)	33.3 (1.31)	37.5 (1.48)	104.5 (4.12)	250.2 (9.85)	186.4 (7.34)	35.7 (1.41)	69.9 (2.75)	1/2"-13
32	2"	207 Bar (3000 PSI)	204.7 (8.06)	127.0 (5.00)	44.5 (1.75)	38.9 (1.53)	126.4 (4.98)	250.2 (9.85)	202.9 (7.99)	42.8 (1.69)	77.7 (3.06)	1/2"-13
BVHS – C.62 – SAE 4-Bolt Flange												
16	1"	414 Bar (6000 PSI)	134.1 (5.28)	79.5 (3.13)	22.4 (0.88)	18.2 (0.72)	97.3 (3.83)	177.8 (7.00)	137.2 (5.40)	65.0 (2.56)	57.2 (2.25)	7/16"-14
20	1 1/4"	414 Bar (6000 PSI)	175.3 (6.90)	101.6 (4.00)	28.7 (1.13)	38.7 (1.53)	97.3 (3.83)	250.2 (9.85)	177.8 (7.00)	78.0 (3.07)	66.8 (2.63)	1/2"-13
24	1 1/2"	414 Bar (6000 PSI)	180.1 (7.09)	108.0 (4.25)	33.3 (1.31)	37.5 (1.48)	104.5 (4.12)	250.2 (9.85)	190.5 (7.50)	94.0 (3.70)	79.5 (3.13)	5/8"-11
32	2"	414 Bar (6000 PSI)	204.7 (8.06)	127.0 (5.00)	44.5 (1.75)	38.9 (1.53)	126.4 (4.98)	250.2 (9.85)	209.3 (8.24)	114.0 (4.49)	96.8 (3.81)	3/4"-10

SAE Split Flange – BVHP

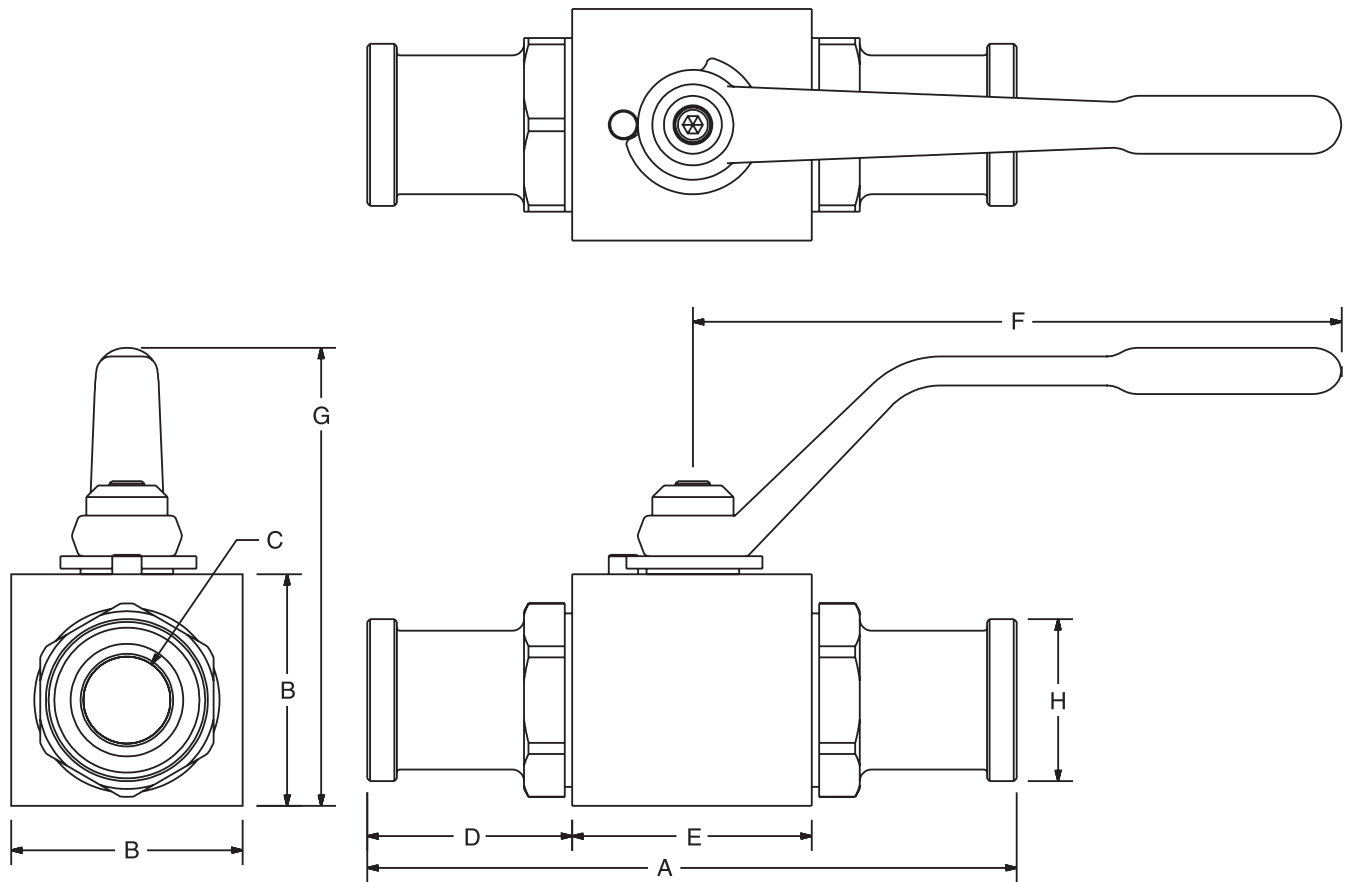

Code	Split Flange Size	Working Pressure*	Dimensions mm (in)							
			A	B	C	D	E	F	G	H
BVHP – C.61 – SAE Split Flange										
08	1/2"	207 Bar (3000 PSI)	151.4 (5.96)	41.4 (1.63)	12.7 (0.50)	51.9 (2.05)	47.5 (1.87)	114.3 (4.50)	82.6 (3.25)	30.2 (1.19)
12	3/4"	207 Bar (3000 PSI)	162.1 (6.38)	57.2 (2.25)	19.1 (0.75)	50.3 (1.98)	61.5 (2.42)	177.8 (7.00)	120.1 (4.73)	38.1 (1.50)
16	1"	207 Bar (3000 PSI)	177.5 (6.99)	63.5 (2.50)	23.9 (0.94)	55.9 (2.20)	65.8 (2.59)	177.8 (7.00)	126.5 (4.98)	44.5 (1.75)
BVHP – C.62 – SAE Split Flange										
08	1/2"	414 Bar (6000 PSI)	151.1 (5.95)	41.4 (1.63)	12.7 (0.50)	51.8 (2.04)	47.5 (1.87)	114.3 (4.50)	82.6 (3.25)	31.8 (1.25)
12	3/4"	414 Bar (6000 PSI)	174.2 (6.86)	57.2 (2.25)	19.1 (0.75)	56.4 (2.22)	61.5 (2.42)	177.8 (7.00)	120.1 (4.73)	41.3 (1.63)
16	1"	414 Bar (6000 PSI)	197.9 (7.79)	63.5 (2.50)	23.9 (0.94)	66.0 (2.60)	65.8 (2.59)	177.8 (7.00)	126.5 (4.98)	47.8 (1.88)

* BVHP16 in stainless steel is rated to 207 Bar (3000 PSI).

SAE Split Flange – BVAH

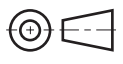
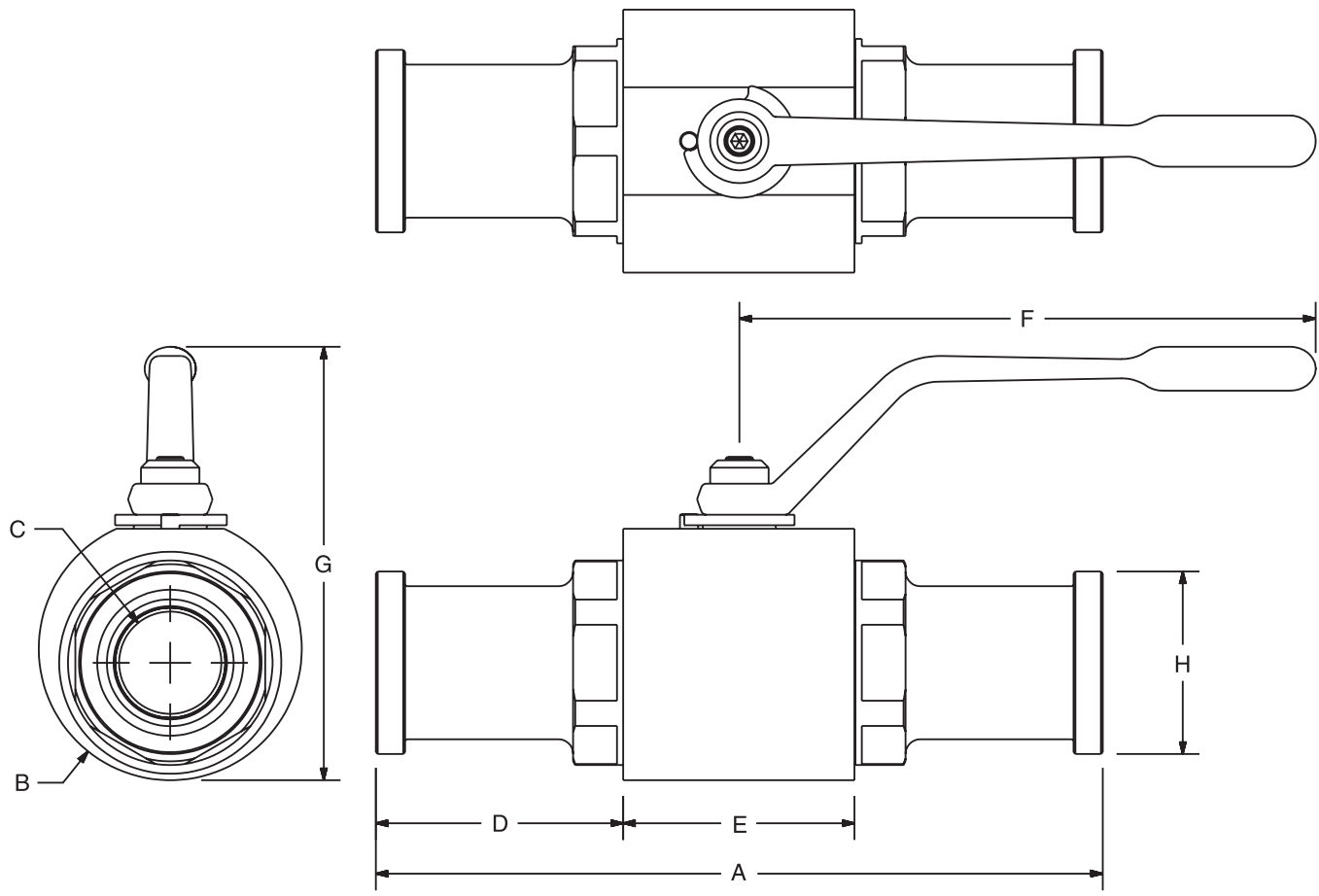

Code	Split Flange Size	Working Pressure*	Dimensions mm (in)							
			A	B	C	D	E	F	G	H
BVAH – C.61 – SAE Split Flange										
20	1 1/4"	207 Bar (3000 PSI)	190.5 (7.50)	85.9 (3.38)	31.8 (1.25)	54.8 (2.16)	80.5 (3.17)	250.2 (9.85)	163.8 (6.45)	50.8 (2.00)
24	1 1/2"	207 Bar (3000 PSI)	230.9 (9.09)	95.3 (3.75)	38.1 (1.50)	72.4 (2.85)	85.5 (3.37)	250.2 (9.85)	173.2 (6.82)	60.3 (2.38)
32	2"	207 Bar (3000 PSI)	231.1 (9.10)	114.3 (4.50)	47.8 (1.88)	65.0 (2.56)	100.5 (3.96)	250.2 (9.85)	190.2 (7.49)	71.4 (2.81)
BVAH – C.62 – SAE Split Flange										
20	1 1/4"	414 Bar (6000 PSI)	222.8 (8.77)	85.9 (3.38)	31.8 (1.25)	70.9 (2.79)	80.5 (3.17)	250.2 (9.85)	166.8 (6.45)	54.0 (2.13)
24	1 1/2"	414 Bar (6000 PSI)	280.9 (11.06)	95.3 (3.75)	38.1 (1.50)	97.5 (3.84)	85.5 (3.37)	250.2 (9.85)	173.2 (6.82)	63.5 (2.50)
32	2"	414 Bar (6000 PSI)	316.0 (12.44)	114.3 (4.50)	47.8 (1.88)	107.5 (4.23)	100.5 (3.96)	250.2 (9.85)	190.2 (7.49)	79.4 (3.13)

* BVAH in stainless steel is rated to 207 Bar (3000 PSI).

SAE Split Flange – BVHS

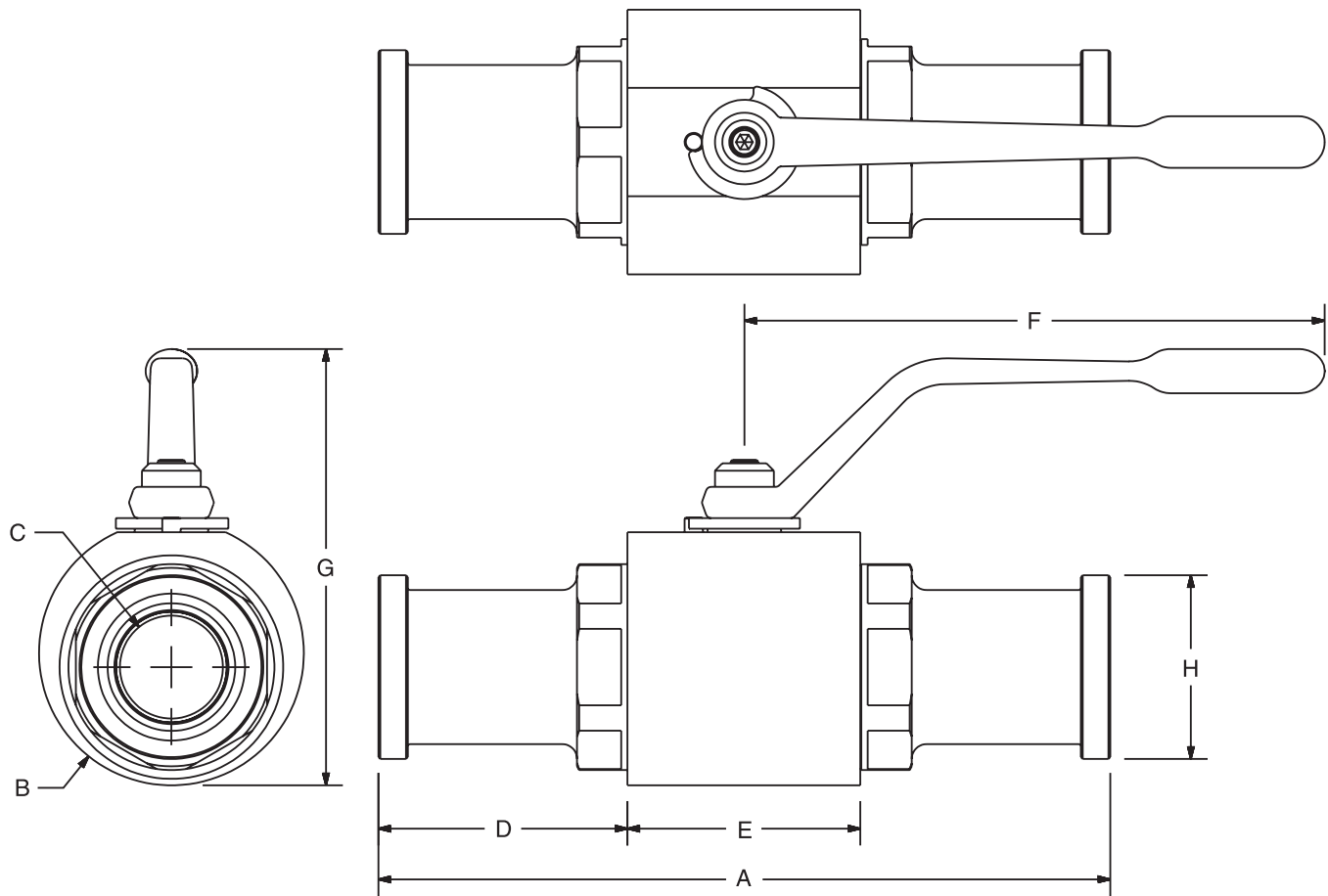

Code	Split Flange Size	Working Pressure	Dimensions mm (in)							
			A	B	C	D	E	F	G	H
BVHS – C.61 – SAE Split Flange										
16	1"	207 Bar (3000 PSI)	177.5 (6.99)	79.5 (3.13)	22.4 (0.88)	39.9 (1.57)	97.3 (3.83)	177.8 (7.00)	137.2 (5.40)	44.5 (1.75)
20	1 1/4"	207 Bar (3000 PSI)	190.8 (7.51)	101.6 (4.00)	28.7 (1.13)	46.5 (1.83)	97.3 (3.83)	250.2 (9.85)	177.8 (7.00)	50.8 (2.00)
24	1 1/2"	207 Bar (3000 PSI)	249.9 (9.84)	108.0 (4.25)	33.3 (1.31)	72.4 (2.85)	104.5 (4.12)	250.2 (9.85)	186.4 (7.34)	60.3 (2.38)
32	2"	207 Bar (3000 PSI)	257.0 (10.12)	127.0 (5.00)	44.5 (1.75)	65.0 (2.56)	126.4 (4.98)	250.2 (9.85)	202.9 (7.99)	71.4 (2.81)
BVHS – C.62 – SAE Split Flange										
16	1"	414 Bar (6000 PSI)	197.9 (7.79)	79.5 (3.13)	22.4 (0.88)	50.0 (1.97)	97.3 (3.83)	177.8 (7.00)	137.2 (5.40)	47.8 (1.88)
20	1 1/4"	414 Bar (6000 PSI)	222.8 (8.77)	101.6 (4.00)	28.7 (1.13)	62.5 (2.46)	97.3 (3.83)	250.2 (9.85)	177.8 (7.00)	54.0 (2.13)
24	1 1/2"	414 Bar (6000 PSI)	280.9 (11.06)	108.0 (4.25)	33.3 (1.31)	87.9 (3.46)	104.5 (4.12)	250.2 (9.85)	186.4 (7.34)	63.5 (2.50)
32	2"	414 Bar (6000 PSI)	316.0 (12.44)	127.0 (5.00)	44.5 (1.75)	94.5 (3.72)	126.4 (4.98)	250.2 (9.85)	202.9 (7.99)	79.4 (3.13)

Combination SAE 4-Bolt and SAE Split Flange – BVAH

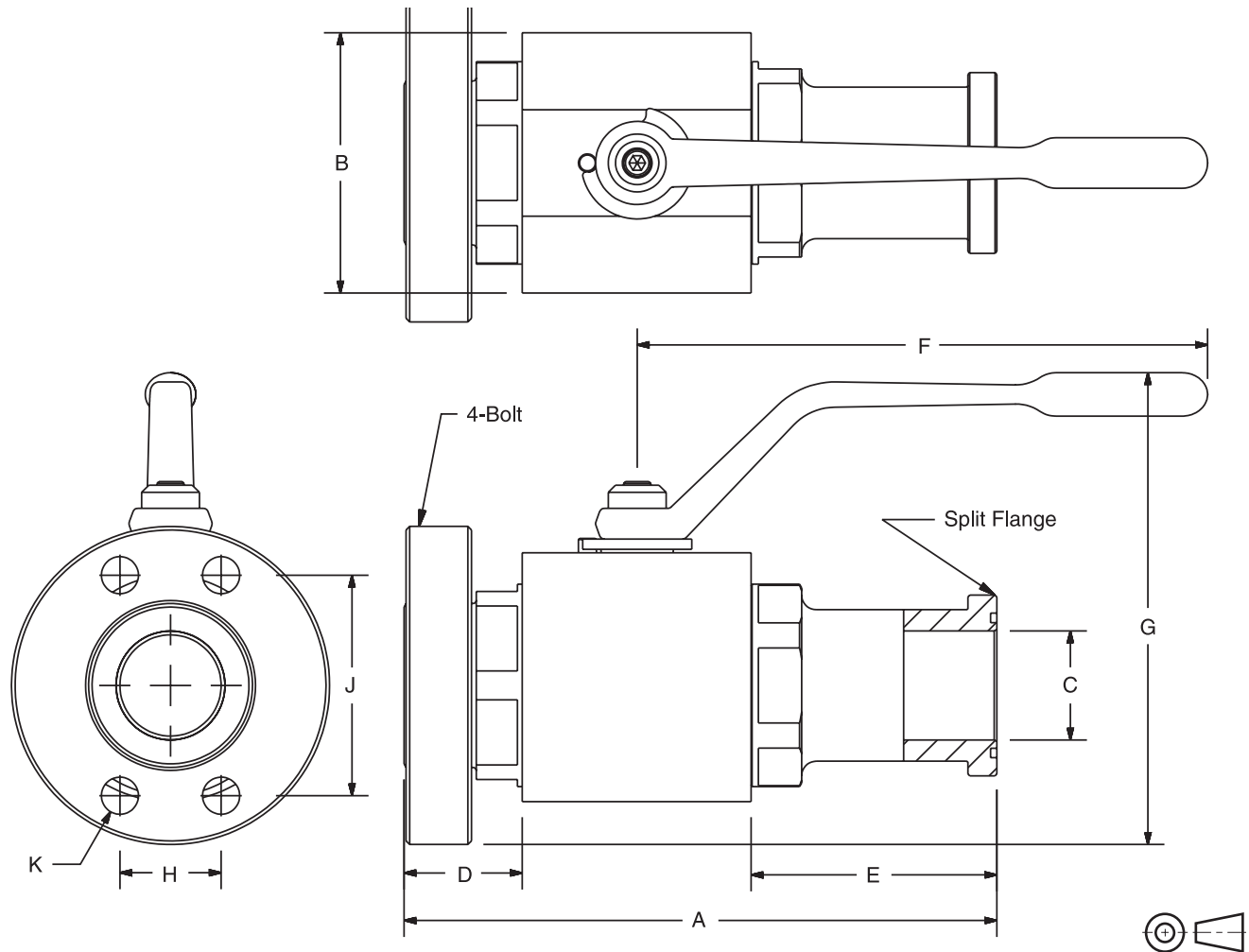

Code	SAE Flange Size	Working Pressure*	Dimensions mm (in)									
			A	B	C	D	E	F	G	H	J	K
BVAH – C.61 – SAE 4-Bolt and SAE Split Flange Combination												
20	1 1/4"	207 Bar (3000 PSI)	182.9 (7.20)	85.9 (3.38)	31.8 (1.25)	47.6 (1.88)	54.8 (2.16)	250.2 (9.85)	170.0 (6.69)	30.2 (1.19)	58.7 (2.31)	7/16"-14
24	1 1/2"	207 Bar (3000 PSI)	205.5 (8.09)	95.3 (3.75)	38.1 (1.50)	47.5 (1.87)	72.4 (2.85)	250.2 (9.85)	179.7 (7.07)	35.8 (1.41)	69.9 (2.75)	1/2"-13
32	2"	207 Bar (3000 PSI)	217.9 (8.58)	114.3 (4.50)	47.8 (1.88)	52.4 (2.06)	65.0 (2.56)	250.2 (9.85)	196.6 (7.74)	42.9 (1.69)	77.7 (3.06)	1/2"-13
BVAH – C.62 – SAE 4-Bolt and SAE Split Flange Combination												
20	1 1/4"	414 Bar (6000 PSI)	198.9 (7.83)	85.9 (3.38)	31.8 (1.25)	47.6 (1.88)	70.9 (2.79)	250.2 (9.85)	174.8 (6.88)	31.8 (1.25)	66.8 (2.63)	1/2"-13
24	1 1/2"	414 Bar (6000 PSI)	230.6 (9.08)	95.3 (3.75)	38.1 (1.50)	47.5 (1.87)	97.5 (3.84)	250.2 (9.85)	189.2 (7.45)	36.6 (1.44)	79.2 (3.12)	5/8"-11
32	2"	414 Bar (6000 PSI)	260.4 (10.25)	114.3 (4.50)	47.8 (1.88)	52.4 (2.06)	107.4 (4.23)	250.2 (9.85)	209.3 (8.24)	44.5 (1.75)	96.8 (3.81)	3/4"-10

* BVAH in stainless steel is rated to 207 Bar (3000 PSI).

Combination SAE 4-Bolt and SAE Split Flange – BVHS

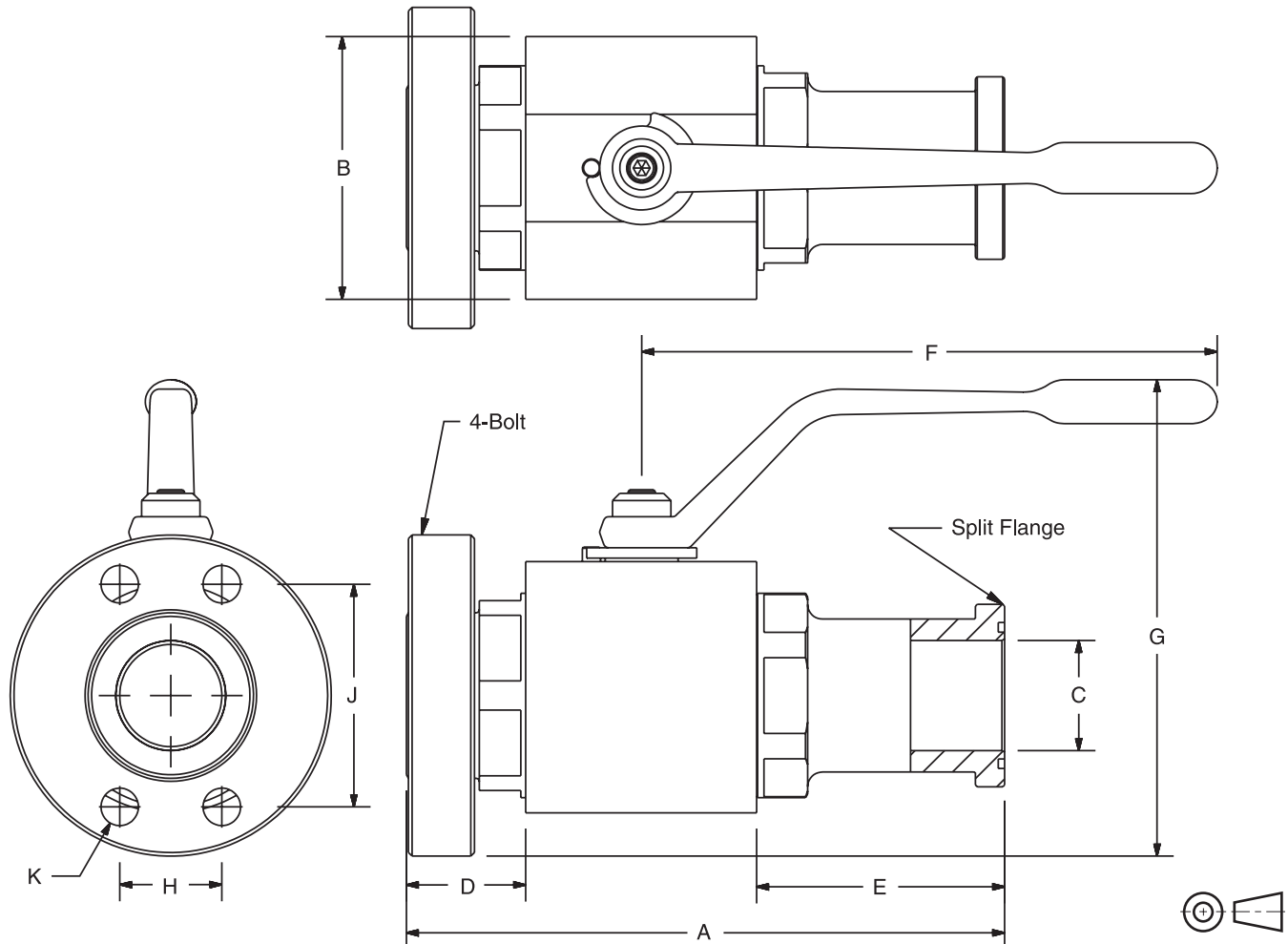

Code	SAE Flange Size	Working Pressure	Dimensions mm (in)									
			A	B	C	D	E	F	G	H	J	K
BVHS – C.61 – SAE 4-Bolt and SAE Split Flange Combination												
16	1"	207 Bar (3000 PSI)	159.0 (6.26)	79.5 (3.13)	22.4 (0.88)	34.3 (1.35)	52.5 (2.07)	177.8 (7.00)	137.2 (5.40)	26.2 (1.03)	52.3 (2.06)	3/8"-16
20	1 1/4"	207 Bar (3000 PSI)	191.3 (7.53)	101.6 (4.00)	28.7 (1.13)	47.6 (1.88)	46.5 (1.83)	250.2 (9.85)	177.8 (7.00)	30.1 (1.19)	58.7 (2.31)	7/16"-14
24	1 1/2"	207 Bar (3000 PSI)	224.5 (8.84)	108.0 (4.25)	33.3 (1.31)	47.5 (1.87)	72.4 (2.85)	250.2 (9.85)	186.4 (7.34)	35.7 (1.41)	69.9 (2.75)	1/2"-13
32	2"	207 Bar (3000 PSI)	243.8 (9.60)	127.0 (5.00)	44.5 (1.75)	52.4 (2.06)	65.0 (2.56)	250.2 (9.85)	202.9 (7.99)	42.8 (1.69)	77.7 (3.06)	1/2"-13
BVHS – C.62 – SAE 4-Bolt and SAE Split Flange Combination												
16	1"	414 Bar (6000 PSI)	169.2 (6.66)	79.5 (3.13)	22.4 (0.88)	34.3 (1.35)	62.6 (2.47)	177.8 (7.00)	137.2 (5.40)	65.0 (2.56)	57.2 (2.25)	7/16"-14
20	1 1/4"	414 Bar (6000 PSI)	207.3 (8.16)	101.6 (4.00)	28.7 (1.13)	47.6 (1.88)	62.5 (2.46)	250.2 (9.85)	177.8 (7.00)	78.0 (3.07)	66.8 (2.63)	1/2"-13
24	1 1/2"	414 Bar (6000 PSI)	240.0 (9.45)	108.0 (4.25)	33.3 (1.31)	47.5 (1.87)	88.0 (3.47)	250.2 (9.85)	190.5 (7.50)	94.0 (3.70)	79.5 (3.13)	5/8"-13
32	2"	414 Bar (6000 PSI)	273.3 (10.76)	127.0 (5.00)	44.5 (1.75)	52.4 (2.06)	94.5 (3.72)	250.2 (9.85)	209.3 (8.24)	114.0 (4.49)	96.8 (3.81)	3/4"-10

Combination SAE 4-Bolt and SAE Split Flange – BVHP

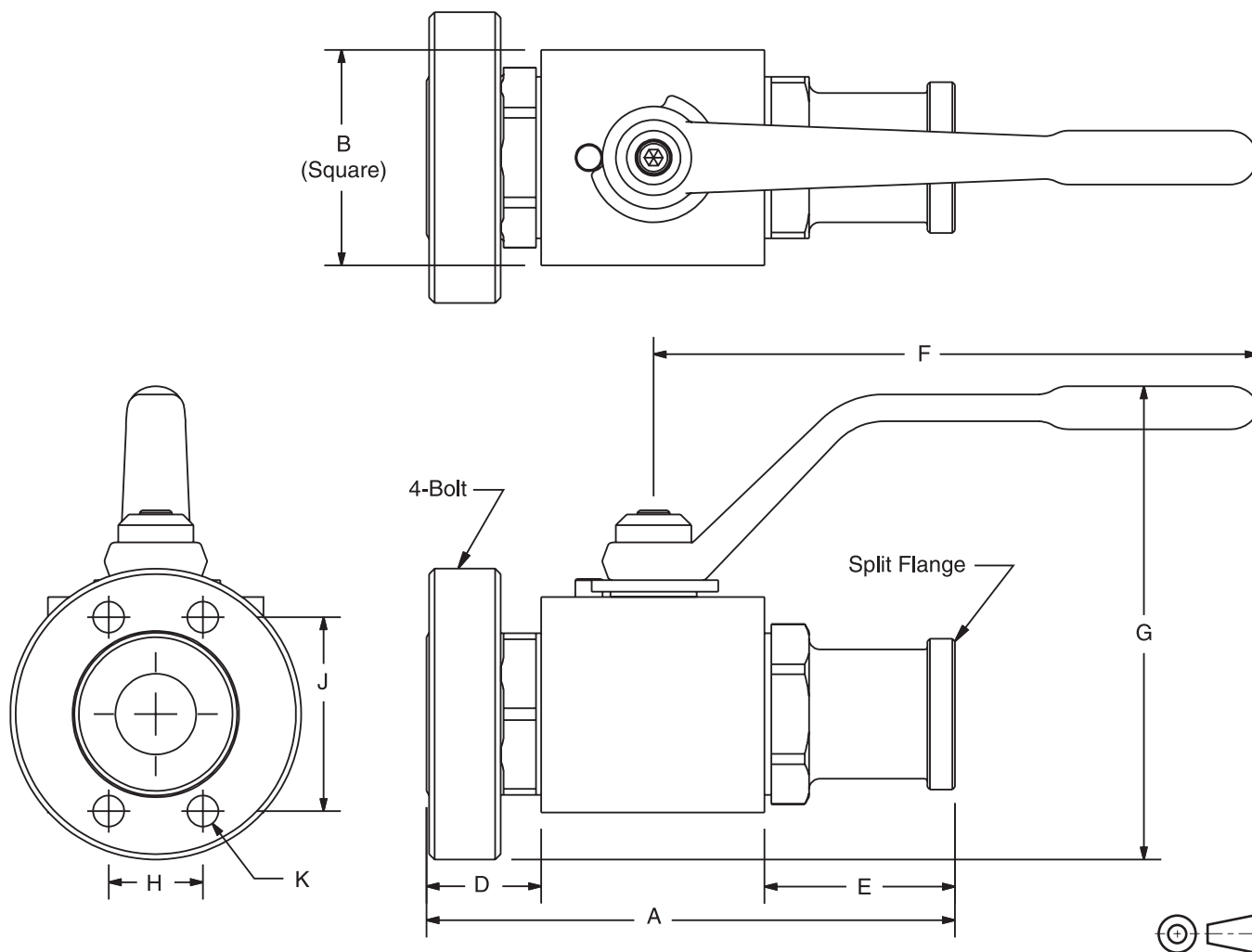

Code	SAE Flange Size	Working Pressure*	Dimensions mm (in)									
			A	B	C	D	E	F	G	H	J	K
BVHP – C.61 – SAE 4-Bolt and SAE Split Flange Combination												
08	1/2"	207 Bar (3000 PSI)	129.8 (5.11)	41.4 (1.63)	12.7 (0.50)	30.1 (1.19)	52.2 (2.06)	114.3 (4.50)	91.0 (3.58)	17.5 (0.69)	38.1 (1.50)	5/16"-18
12	3/4"	207 Bar (3000 PSI)	141.7 (5.58)	57.2 (2.25)	19.1 (0.75)	29.6 (1.17)	50.5 (1.99)	177.8 (7.00)	128.9 (5.08)	22.4 (0.88)	47.6 (1.88)	3/8"-16
16	1"	207 Bar (3000 PSI)	152.4 (6.00)	63.5 (2.50)	23.9 (0.94)	33.8 (1.33)	56.0 (2.21)	177.8 (7.00)	135.4 (5.33)	26.2 (1.03)	52.3 (2.06)	3/8"-16
BVHP – C.62 – SAE 4-Bolt and SAE Split Flange Combination												
08	1/2"	414 Bar (6000 PSI)	129.8 (5.11)	41.4 (1.63)	12.7 (0.50)	30.1 (1.19)	52.1 (2.05)	114.3 (4.50)	92.6 (3.65)	18.3 (0.72)	40.4 (1.59)	5/16"-18
12	3/4"	414 Bar (6000 PSI)	147.8 (5.82)	57.2 (2.25)	19.1 (0.75)	29.6 (1.17)	56.6 (2.23)	177.8 (7.00)	129.8 (5.11)	23.9 (0.94)	50.8 (2.00)	3/8"-16
16	1"	414 Bar (6000 PSI)	165.9 (6.53)	63.5 (2.50)	23.9 (0.94)	33.8 (1.33)	66.3 (2.61)	177.8 (7.00)	140.3 (5.52)	27.7 (1.09)	57.2 (2.25)	7/16"-14

* BVHP16 in stainless steel is rated to 207 Bar (3000 PSI).

Ball Valve Seal Kits restore a ball valve to factory specifications, providing no erosion or metal-to-metal wear has taken place.

The Seal Kit includes all the o-rings, ball seals and thrust bearings that were originally installed at the factory.

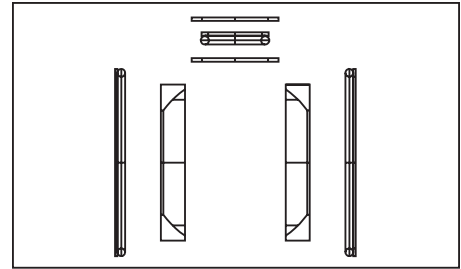

Ordering Information

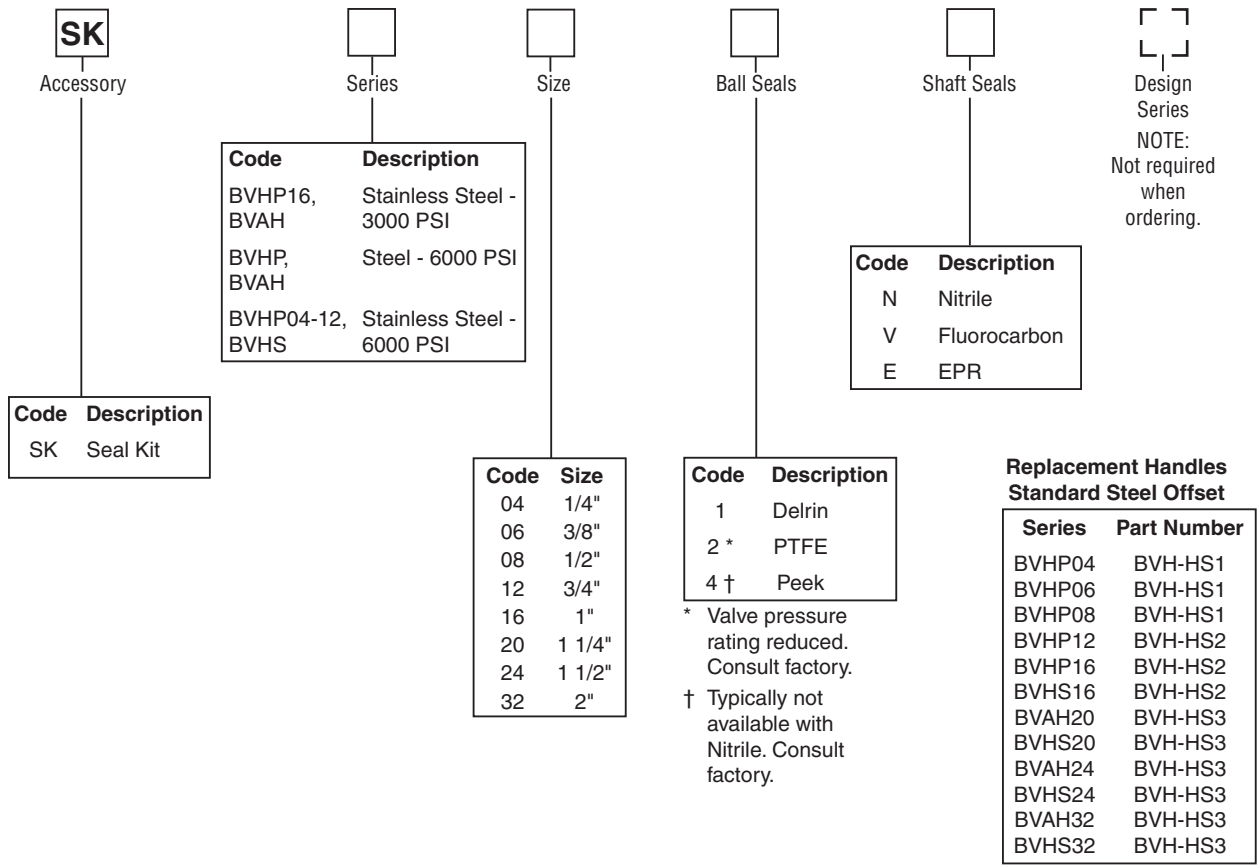

	4	6	8	12	16	20	24	32
Steel - 414 Bar (6000 PSI)	BVHP	BVHP	BVHP	BVHP	BVHP	BVAH	BVAH	BVAH
Stainless Steel - 207 Bar (3000 PSI)	X	X	X	X	BVHP	BVAH	BVAH	BVAH
Stainless Steel - 414 Bar (6000 PSI)	BVHP	BVHP	BVHP	BVHP	BVHS	BVHS	BVHS	BVHS

BVHPLK: Standard Series 'BVHPLK-*' kit replaces the stopwasher with a stationary and moving plate, as illustrated below. As the handle is actuated, the moving plate aligns with one of the two locking positions in the stationary plate, enabling the valve to be locked in either **fully closed** or **fully open** position.

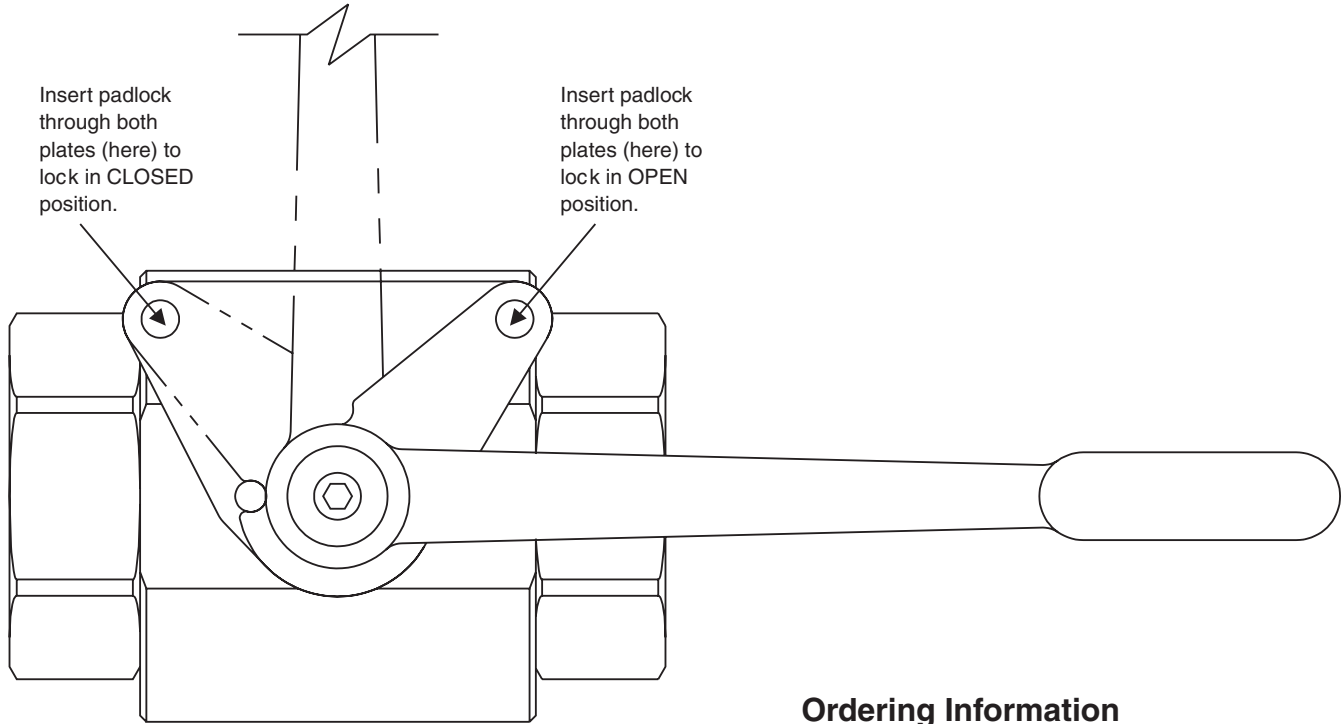

Ordering Information

BVHP, BVAH, BVHS Code	Size	Standard Locking (Part Number)
04	1/4"	BVHPLK-1
06	3/8"	BVHPLK-1
08	1/2"	BVHPLK-1
12	3/4"	BVHPLK-2
16	1"	BVHPLK-2
20	1 1/4"	BVHPLK-3
24	1 1/2"	BVHPLK-3
32	2"	BVHPLK-3

General Description

Series BVHH valves are used for shut-off applications and are rated at 690 Bar (10,000 PSI). These valves represent the strongest ball valve in the industry. Series BVHH valves come in ports 1/2" to 2" and SAE, NPT and BSPP ports.

Operation

Parker's 2-way ball valves operate to either off or full flow by rotating the handle 90°. Ball valves are not designed to be a metering or flow control device.

Specifications

Maximum Pressure	690 Bar (10,000 PSI)
Body Material	Carbon Steel, Black Oxide
Ball Material	Steel, Chrome Plated Stainless Steel
Stem Material	Steel, Zinc Plated Stainless Steel
Standard Handle	Steel Offset, Nickel Plated
Standard Ball Seals	Delrin + MoS ₂
Standard Shaft Seals	O-Ring & Backup, Nitrile
Temperature Range with Standard Seals	-30°C to +100°C (-22°F to +212°F)

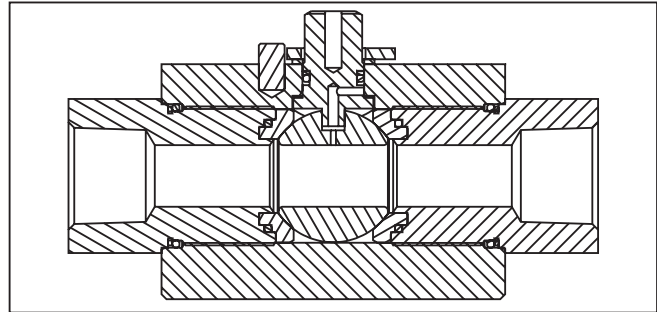
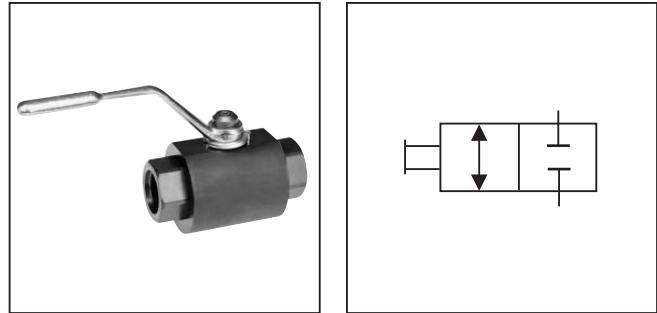

Features

- Encased Delrin moly ball seals increase the reliability compared to ring reinforcement designs.
- The BVHH is fully ported resulting in very low pressure drop.
- Nitrile seals are standard with fluorocarbon and EPR as options.
- The BVHH is available with options found in the 404 Bar (6000 PSI) models.

Performance Curves

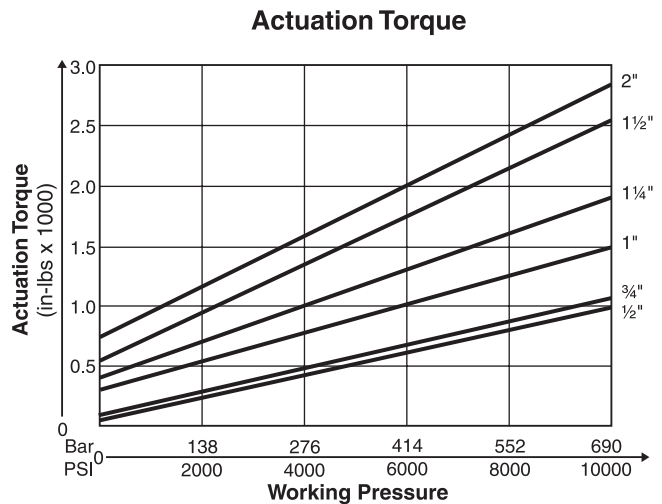
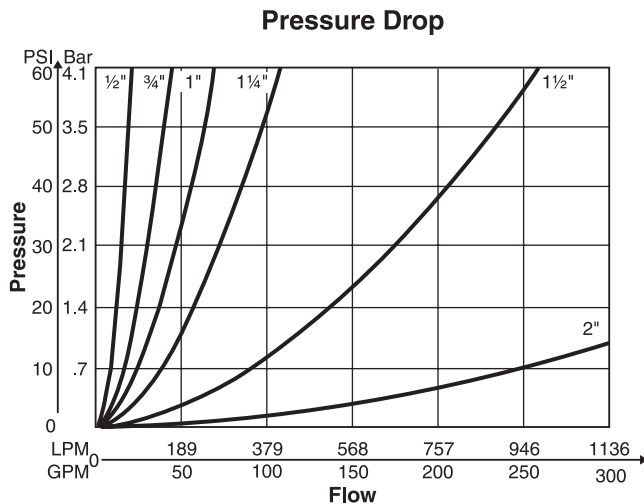

BVHH Series	<input type="checkbox"/> Size	<input type="checkbox"/> Port	S Body Material	<input type="checkbox"/> Ball & Stem Material	<input type="checkbox"/> Ball Seals	<input type="checkbox"/> Shaft Seals	<input type="checkbox"/> Options	<input type="checkbox"/> Design Series NOTE: Not required when ordering.
-----------------------	----------------------------------	----------------------------------	---------------------------	--	--	---	-------------------------------------	---

Code	Size
08	1/2"
12	3/4"
16	1"
20	1 1/4"
24	1 1/2"
32	2"

Code	Description
N	NPT Thread
S	SAE Thread
B	BSPP Thread

Code	Description
S	Steel

Code	Description
S	Steel
K	Stainless Steel

Code	Description
N	Nitrile
V	Fluorocarbon
E	EPR

Code	Description
1	Delrin
4 †	Peek

† Typically not available with Nitrile. Consult factory.

Code	Description
Omit	No Options
A	Locking Handle
B	Security Locking Handle
★C	1-Way Limit Switch
★D	2-Way Limit Switch
*E	Panel Mount
G	Flat Non-offset Handle
★**K	1-Way Limit Switch w/Lock
★L	2-Way Limit Switch w/Lock

* Cannot be combined with other options
 ** Switch is set to indicate valve open condition
 ★ When selecting this option, your ball valve will come with the limit switch bracket, but does not include the switch. The switch is sold separately (Part #LSB)

Code	kg (lbs.)
08	1.6 (3.5)
12	2.0 (4.5)
16	3.2 (7.0)
20	7.9 (17.5)
24	8.7 (19.25)
32	9.8 (21.5)

Seal Kit Accessories

Ball Valve Seal Kits restore a ball valve to factory specifications, providing no erosion or metal-to-metal wear has taken place.

The Seal Kit includes all the o-rings, ball seals and thrust bearings that were originally installed at the factory. A sketch of these parts is provided at the right.

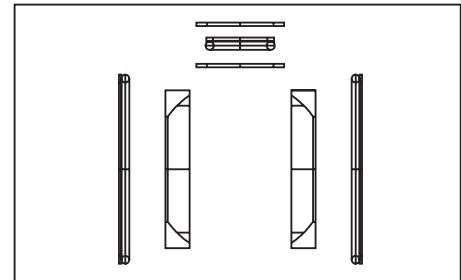

Ordering Information

SK Accessory	BVHH Series	<input type="checkbox"/> Size	<input type="checkbox"/> Ball Seals	<input type="checkbox"/> Shaft Seals	<input type="checkbox"/> Design Series NOTE: Not required when ordering.
------------------------	-----------------------	----------------------------------	--	---	---

Code	Description
SK	Seal Kit

Code	Size
08	1/2"
12	3/4"
16	1"
20	1 1/4"
24	1 1/2"
32	2"

Code	Description
1	Delrin
4 †	Peek

† Typically not available with Nitrile. Consult factory.

Code	Description
N	Nitrile
V	Fluorocarbon
E	EPR

Series	Part Number
BVHH04	BVH-HS1
BVHH06	BVH-HS1
BVHH08	BVH-HS1
BVHH12	BVH-HS2
BVHH16	BVH-HS2
BVHH20	BVH-HS3
BVHH24	BVH-HS3
BVHH32	BVH-HS3

Threaded Ports

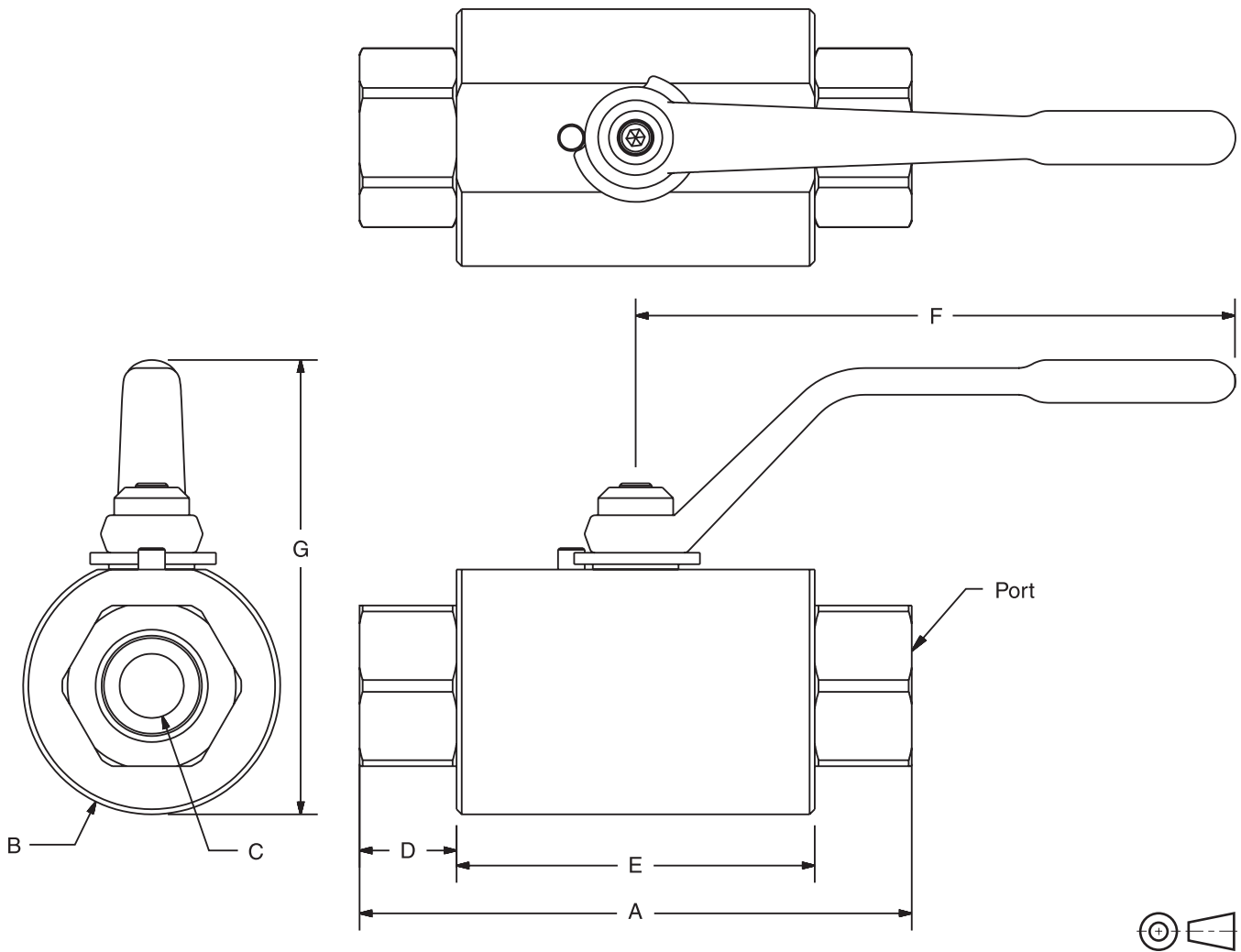

Code	Port Thread Size	Working Pressure	Dimensions mm (in)						
			A	B	C	D	E	F	G
BVHH – NPT, SAE, and BSPP									
08	1/2"	690 Bar (10,000 PSI)	107.2 (4.22)	44.5 (1.75)	9.7 (0.38)	22.1 (0.87)	62.5 (2.46)	114.3 (4.50)	83.1 (3.27)
12	3/4"	690 Bar (10,000 PSI)	119.9 (4.72)	63.5 (2.50)	14.2 (0.56)	19.1 (0.75)	82.3 (3.24)	177.8 (7.00)	122.9 (4.84)
16	1"	690 Bar (10,000 PSI)	135.1 (5.32)	69.9 (2.75)	19.1 (0.75)	25.7 (1.01)	83.8 (3.30)	177.8 (7.00)	129.3 (5.09)
20	1 1/4"	690 Bar (10,000 PSI)	157.5 (6.20)	88.9 (3.50)	22.9 (0.90)	28.1 (1.11)	100.9 (3.97)	250.4 (9.86)	165.1 (6.50)
24	1 1/2"	690 Bar (10,000 PSI)	157.7 (6.21)	101.6 (4.00)	28.7 (1.13)	27.2 (1.07)	102.9 (4.05)	250.4 (9.83)	175.5 (6.91)
32	2"	690 Bar (10,000 PSI)	186.7 (7.35)	114.3 (4.50)	38.1 (1.50)	26.2 (1.03)	133.9 (5.27)	250.4 (9.86)	192.8 (7.59)

BVHPLK: Standard Series 'BVHPLK-*' kit replaces the stopwasher with a stationary and moving plate, as illustrated below. As the handle is actuated, the moving plate aligns with one of the two locking positions in the stationary plate, enabling the valve to be locked in either **fully closed** or **fully open** position.

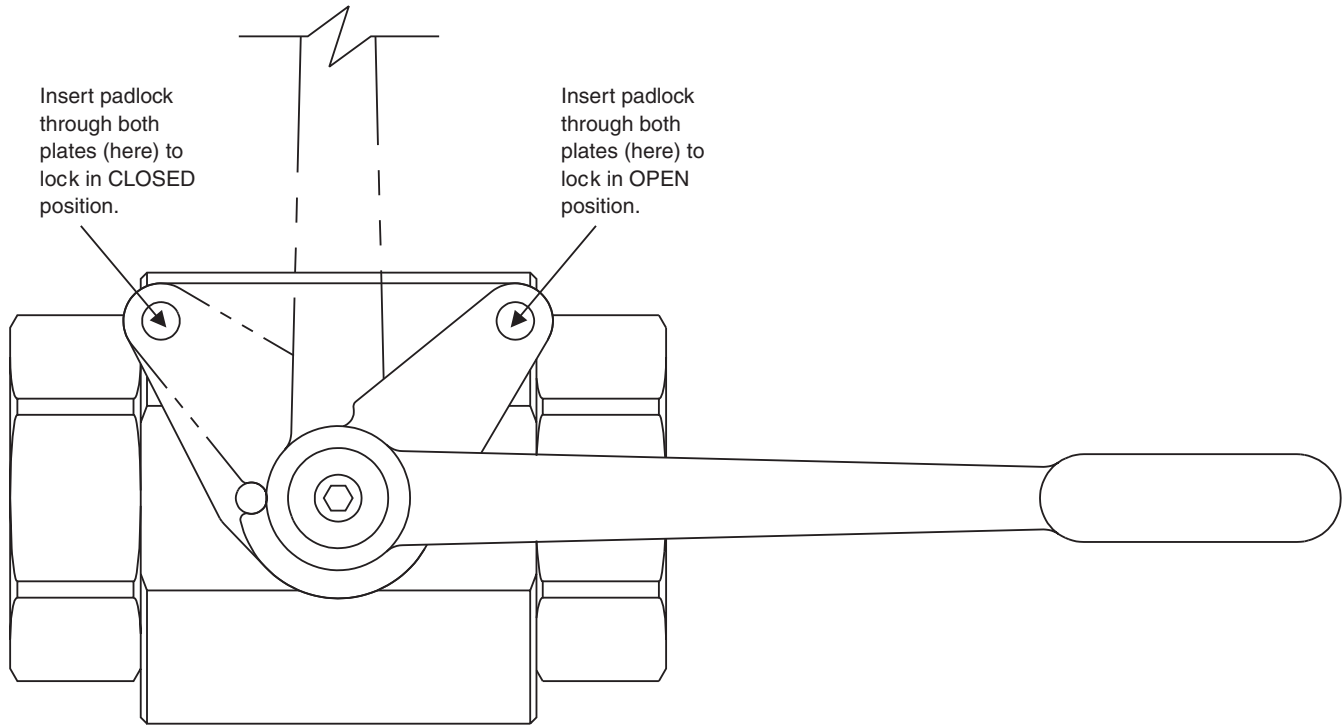

Ordering Information

BVHH		Standard Locking (Part Number)
Code	Size	
08	1/2"	BVHPLK-1
12	3/4"	BVHPLK-2
16	1"	BVHPLK-2
20	1 1/4"	BVHPLK-3
24	1 1/2"	BVHPLK-3
32	2"	BVHPLK-3

General Description

Series BVAM are 2-way ball valves rated at 138 Bar (2000 PSI). This product provides a cost effective solution where 414 Bar (6000 PSI) is not required. Many features found on the 414 Bar (6000 PSI) unit are incorporated in this cost effective product.

Operation

Parker's 2-way ball valves operate to either off or full flow by rotating the handle 90°. Ball valves are not designed to be a metering or flow control device.

Specifications

Maximum Pressure	138 Bar (2000 PSI)
Body Material	Carbon Steel, Black Oxide
Ball Material	Steel, Chrome Plated
Stem Material	Steel, Zinc Plated
Standard Handle	Steel Offset, Nickel Plated
Standard Ball Seals	Delrin + MoS ₂
Standard Shaft Seals	O-Ring & Backup, Nitrile
Temperature Range with Standard Seals	-30°C to +100°C (-22°F to +212°F)

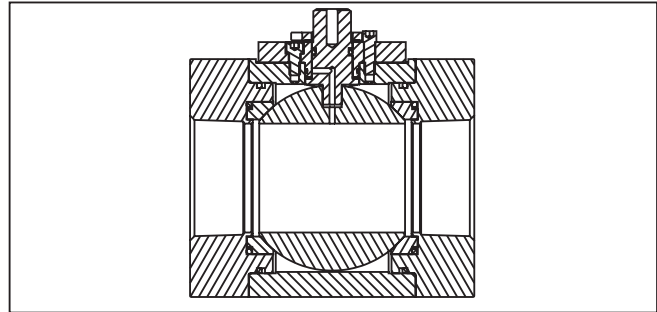
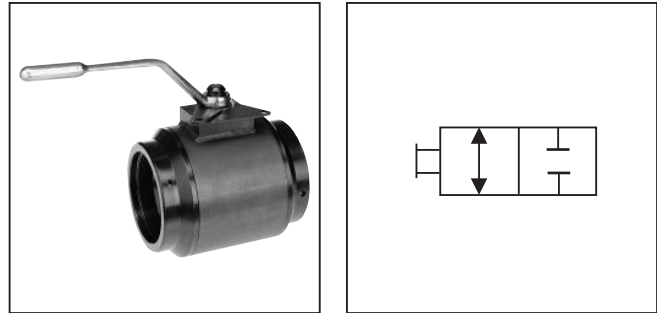

Features

- A full range of threaded porting options allows mounting in most applications.
- The use of MoS₂ mounted ball seals and synthetic lubricant creates a low actuation torque and ensures long life.
- The wide range of spindle and ball sealing materials allows use in most known fluid applications.

Performance Curves

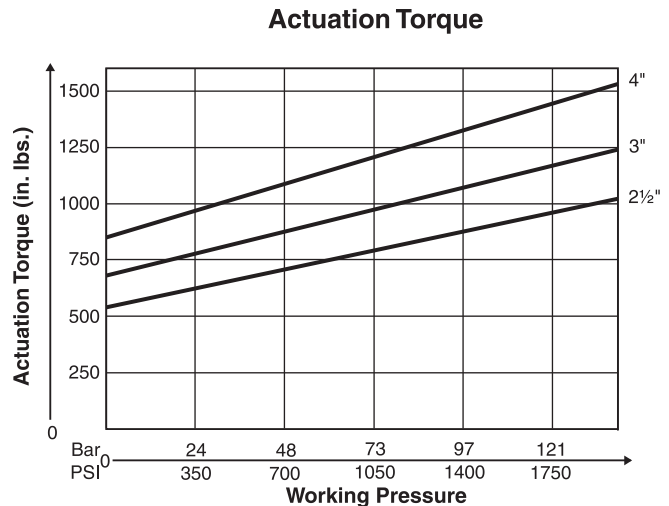
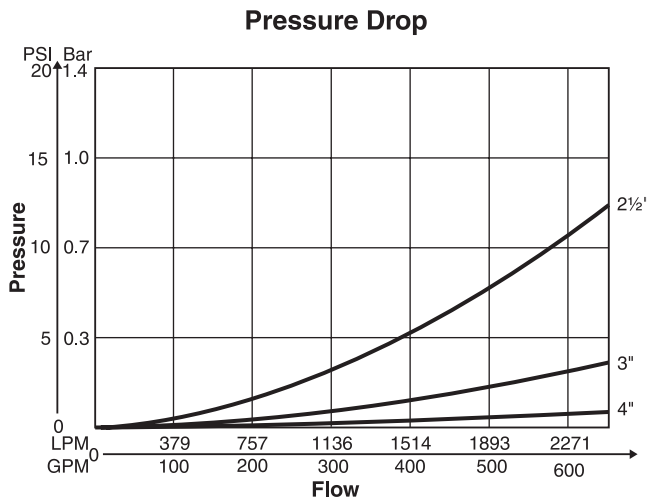

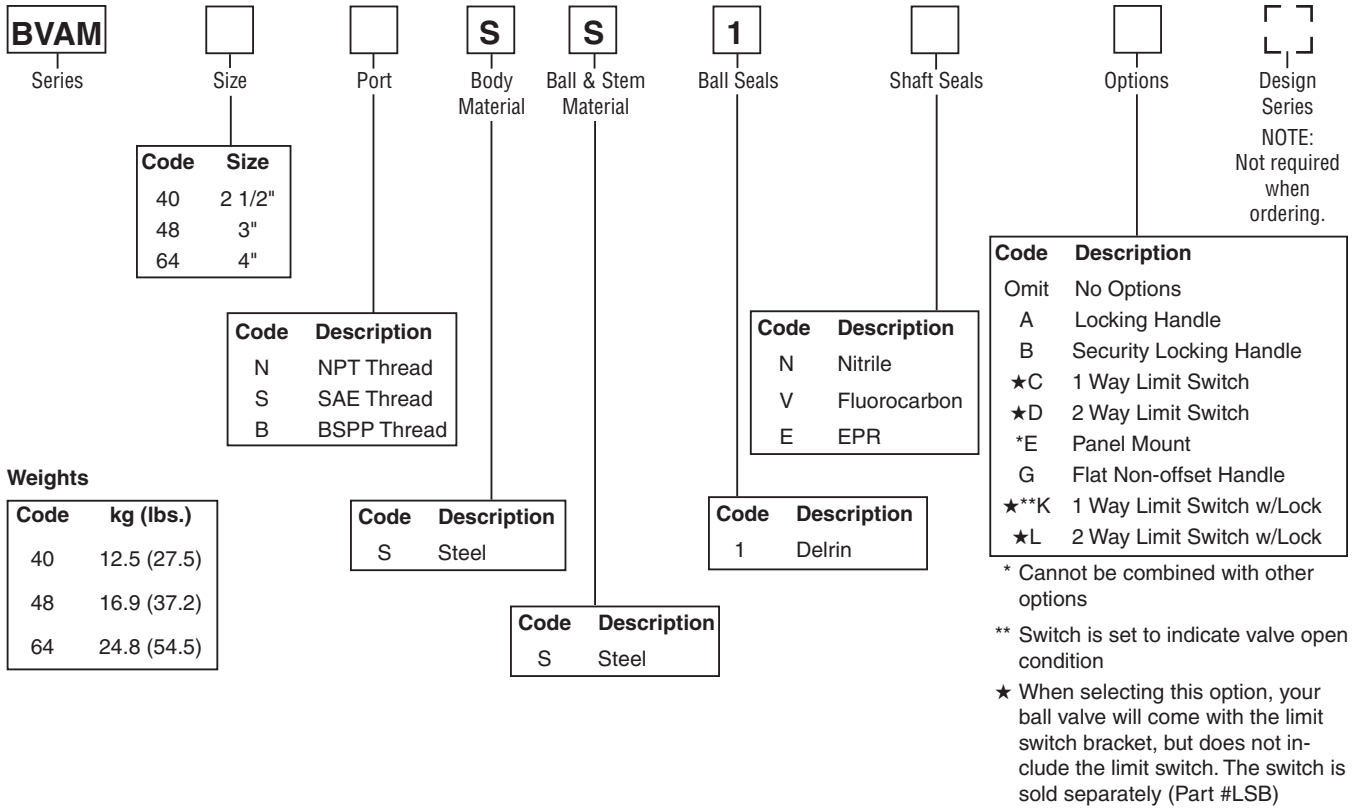

Seal Kit Accessories

Ball Valve Seal Kits restore a ball valve to factory specifications, providing no erosion or metal-to-metal wear has taken place.

The Seal Kit includes all the o-rings, ball seals and thrust bearings that were originally installed at the factory.

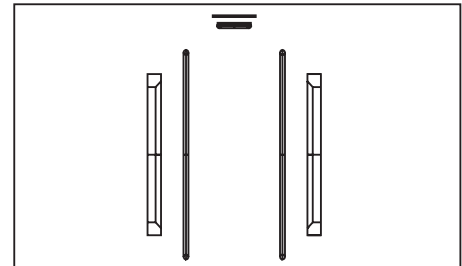

Ordering Information

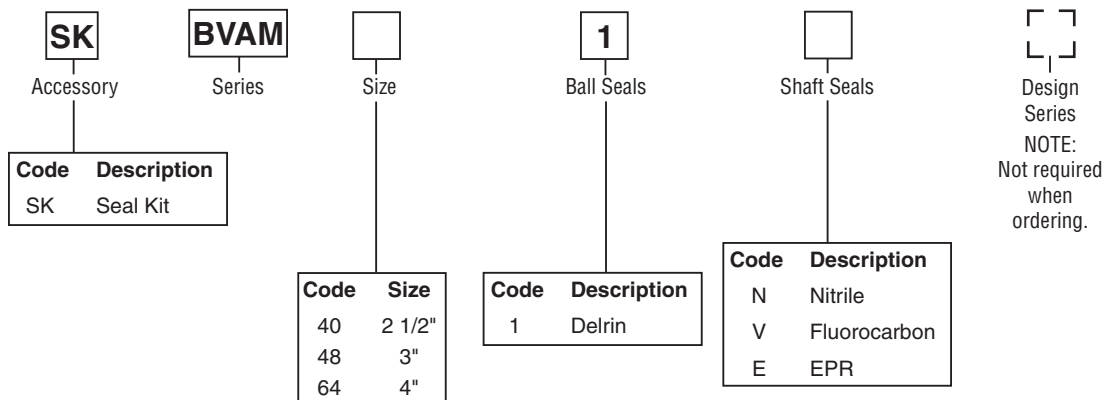

Threaded Ports

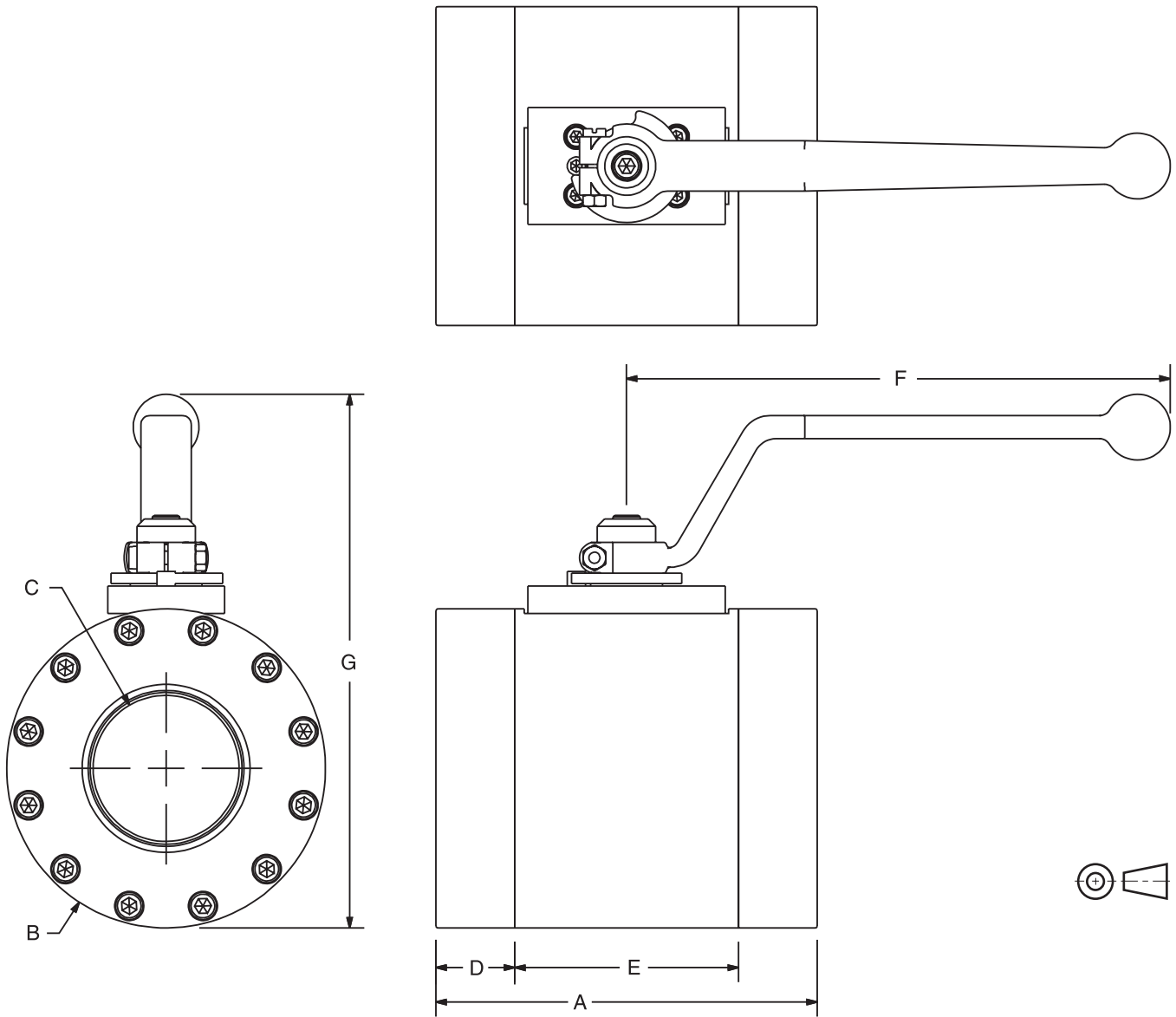

Code	Port Thread Size	Working Pressure	Dimensions mm (in)						
			A	B	C	D	E	F	G
BVAM – NPT, SAE and BSPP									
40	2 1/2"	138 Bar (2000 PSI)	165.9 (6.53)	138.7 (5.46)	63.5 (2.50)	34.2 (1.35)	97.3 (3.83)	250.4 (9.86)	227.8 (8.97)
48	3"	138 Bar (2000 PSI)	182.6 (7.19)	158.8 (6.25)	76.2 (3.00)	39.7 (1.56)	103.2 (4.06)	250.4 (9.86)	248.7 (9.79)
64	4"	138 Bar (2000 PSI)	216.4 (8.52)	190.5 (7.50)	95.3 (3.75)	38.9 (1.53)	138.4 (5.45)	368.3 (14.50)	292.9 (11.53)

BVHPLK: Standard Series 'BVHPLK-*' kit replaces the stopwasher with a stationary and moving plate, as illustrated below. As the handle is actuated, the moving plate aligns with one of the two locking positions in the stationary plate, enabling the valve to be locked in either **fully closed** or **fully open** position.

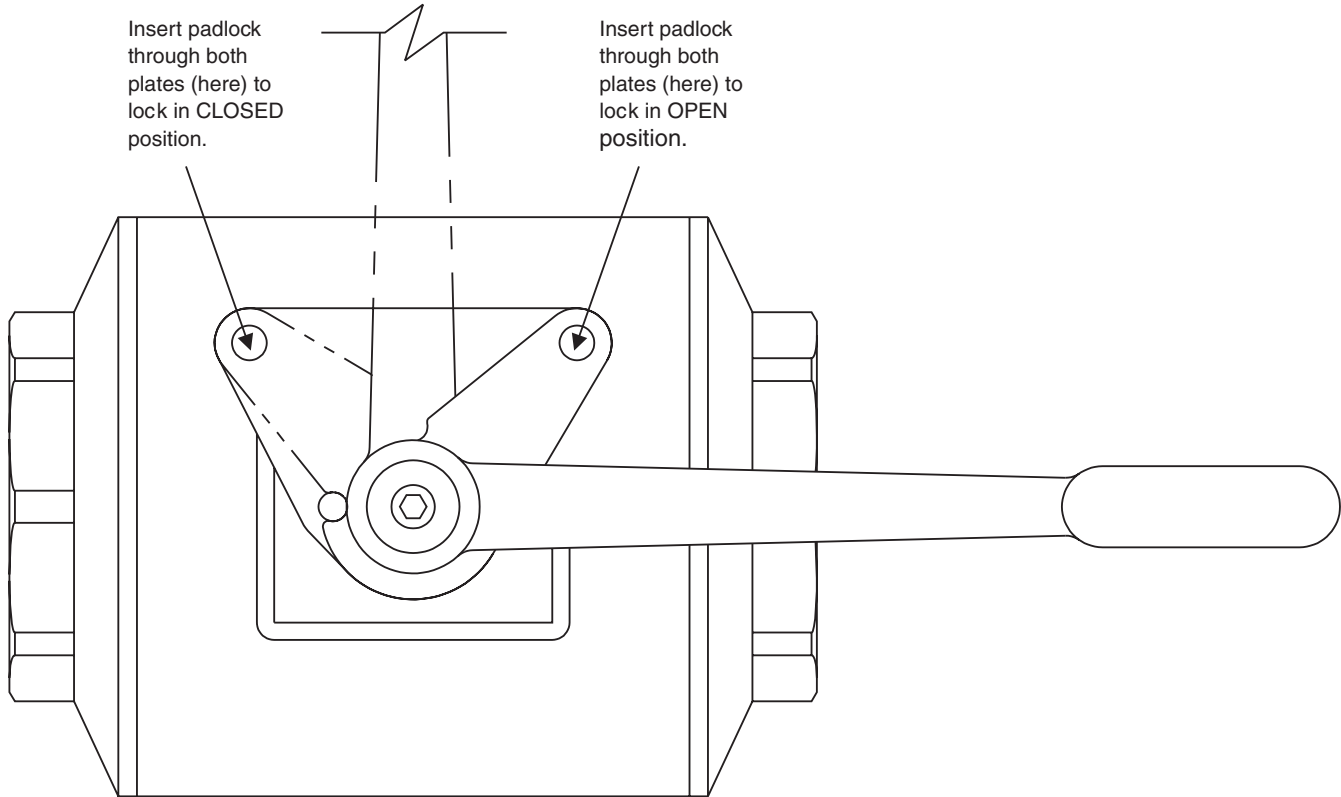

Ordering Information

BVAM		Standard Locking (Part Number)
Code	Size	
40	2 1/2"	BVHPLK-4
48	3"	BVHPLK-4
64	4"	BVHPLK-4

General Description

Series BV3D is a 3-way diverter. The product is rated at 207 Bar (3000 PSI) and designed to economically satisfy many 3-way applications.

Operation

Series BV3D operates by rotating the handle 90° or 180° depending on the chosen ball pattern. There is a slight port to port overlap. Pressure is applied to Port 1.

Specifications

Maximum Pressure	207 Bar (3000 PSI)
Body Material	Carbon Steel, Black Oxide Stainless Steel
Ball Material	Steel, Chrome Plated
Stem Material	Steel, Zinc Plated Stainless Steel
Standard Handle	Steel Offset, Nickel Plated
Standard Ball Seals	Delrin + MoS ₂
Standard Shaft Seals	O-Ring & Backup, Nitrile
Temperature Range with Standard Seals	-30°C to +100°C (-22°F to +212°F)

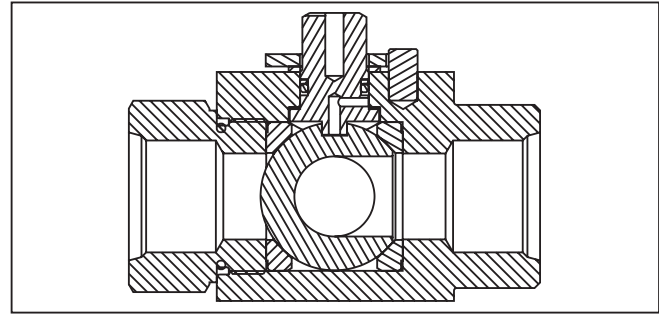
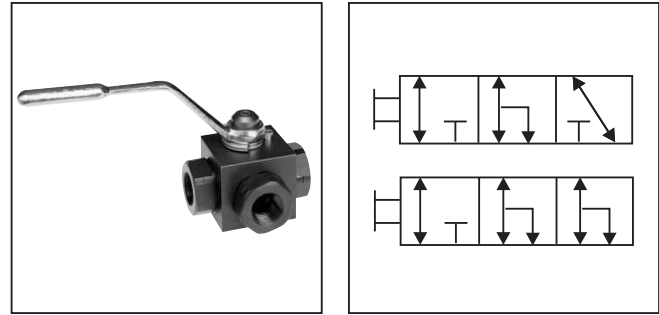

Features

- The standard L-bore ball and T-bore option allows the valve to be utilized in a variety of applications.
- Slight port overlap reduces upstream shock during shifting.
- Utilizing the unique spindle thrust bearing design reduces actuation torque.
- The BV3D can be panel mounted which allows a variety of installation options.
- Delrin seals with molybdenum disulphide (MoS₂) results in lower actuation torque and will increase high duty life cycle expectancy.

Performance Curves

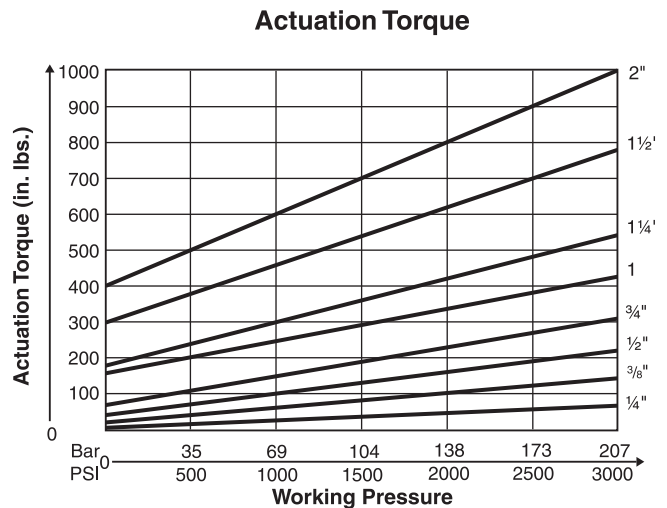
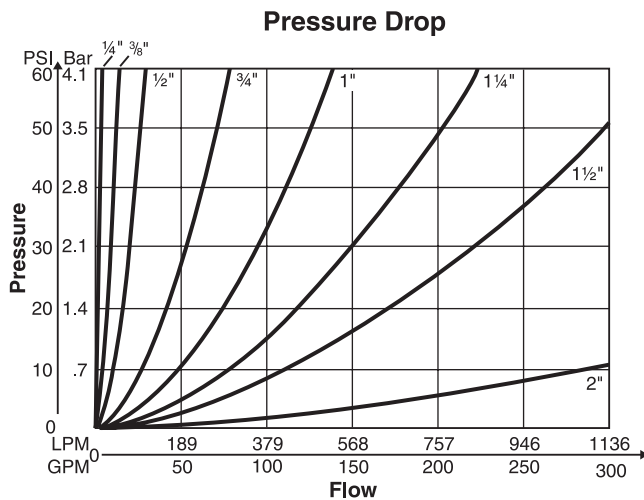

BV3D	□	□	□	□	□	□	□	□	□	□
Series	Size	Port	Ball Pattern	Body Material	Ball & Stem Material	Ball Seals	Shaft Seals	Options	Design Series	NOTE: Not required when ordering.

Code	Size
04	1/4"
06	3/8
08	1/2"
12	3/4"
16	1"
20	1 1/4"
24	1 1/2"
32	2"

Code	Description
N	NPT Thread
S	SAE Thread
B	BSPP Thread
U	ISO 6149 Thread

Code	Description
1	Delrin
2 *	PTFE
4 †	Peek

* Valve pressure rating reduced. Consult factory.
 † Typically not available with Nitrile. Consult factory.

Code	Description
S	Steel
K	Stainless Steel

Code	Description
S	Steel
K	Stainless Steel

Code	Description
Omit	No Options
A	Locking Handle
★C	1-Way Limit Switch
*E	Panel Mount
G	Flat Non-offset Handle
★**K	1-Way Limit Switch w/Lock

* Cannot be combined with other options
 ** Switch is set to indicate valve open condition
 ★ When selecting this option, your ball valve will come with limit switch bracket, but does not include the switch. The switch is sold separately (Part #LSB)

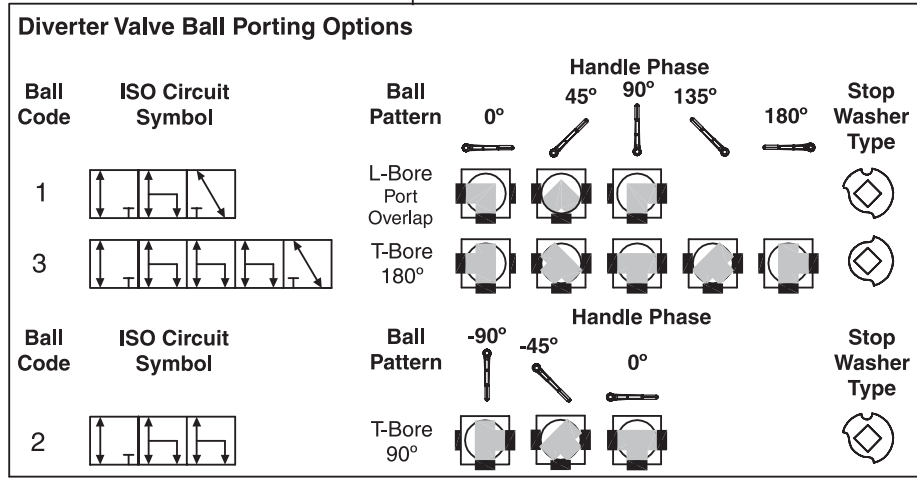

Pressure is applied to Port 1.

ISO 6149-1 Port Dimensions (inches)

Weights

Code	kg (lbs.)	Code	kg (lbs.)
04	0.6 (1.25)	16	2.7 (6.0)
06	0.7 (1.5)	20	6.2 (13.75)
08	0.9 (2.0)	24	6.8 (15.0)
12	1.9 (4.25)	32	11.1 (24.5)

Size	Thread
04	M12 x 1.5
06	M16 x 1.5
08	M18 x 1.5
12	M27 x 2
16	M33 x 2
20	M42 x 2
24	M48 x 2
32	M60 x 2

Threaded Ports

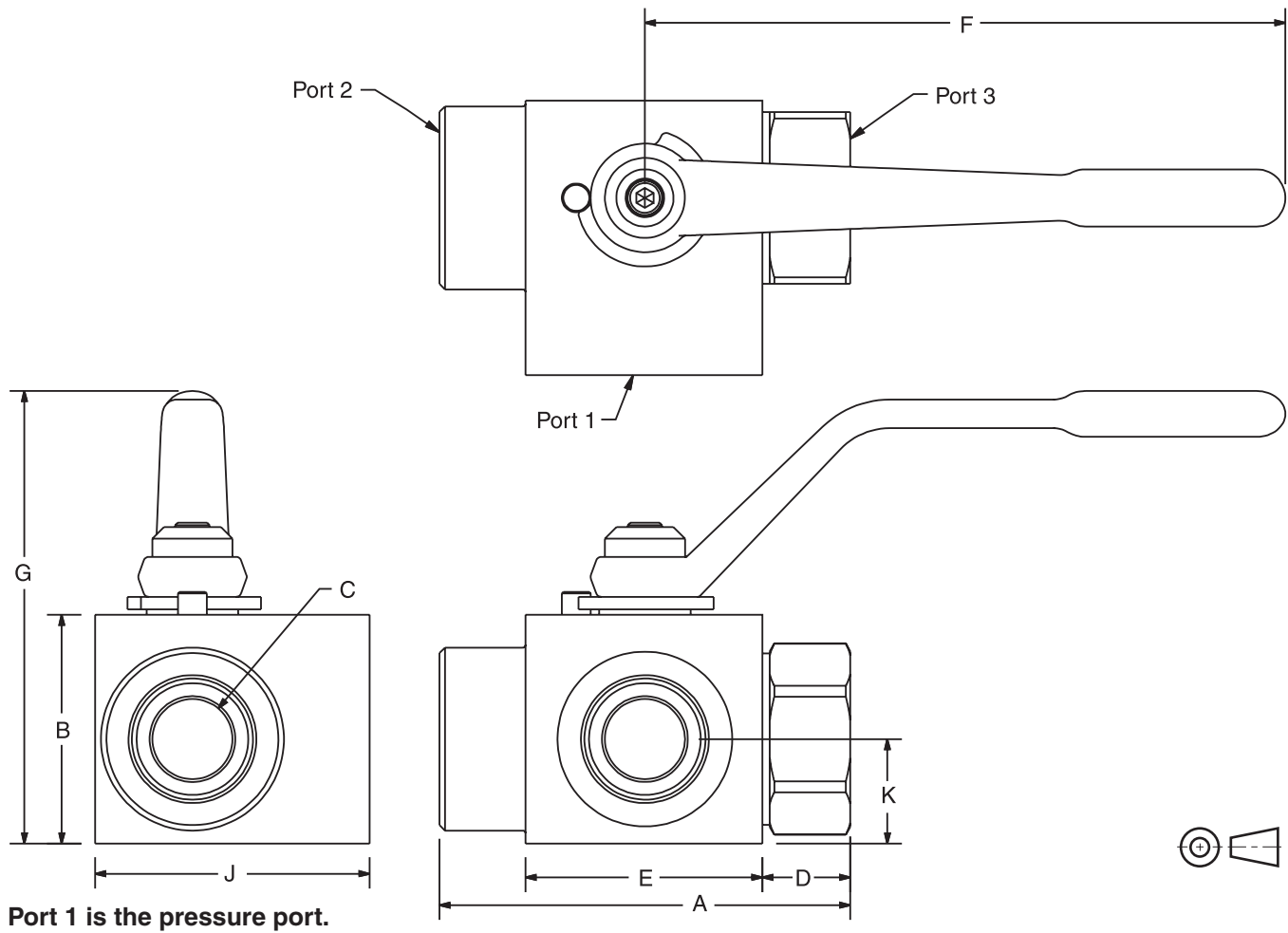

Code	Port Thread Size	Working Pressure	Dimensions mm (in)								
			A	B	C	D	E	F	G	J	K
BV3D – NPT, SAE, and BSPP											
04	1/4"	207 Bar (3000 PSI)	69.6 (2.74)	35.1 (1.38)	6.4 (0.25)	17.3 (0.68)	35.7 (1.40)	114.3 (4.50)	75.7 (2.98)	52.1 (2.05)	15.5 (0.61)
06	3/8"	207 Bar (3000 PSI)	72.9 (2.87)	38.1 (1.50)	7.9 (0.31)	15.5 (0.61)	42.4 (1.67)	114.3 (4.50)	78.7 (3.10)	53.1 (2.09)	16.3 (0.64)
08	1/2"	207 Bar (3000 PSI)	85.3 (3.36)	41.4 (1.63)	11.2 (0.44)	19.3 (0.76)	47.5 (1.87)	114.3 (4.50)	82.6 (3.25)	59.9 (2.36)	18.5 (0.73)
12	3/4"	207 Bar (3000 PSI)	97.0 (3.82)	57.2 (2.25)	17.5 (0.69)	17.5 (0.69)	61.5 (2.42)	177.8 (7.00)	120.1 (4.73)	74.2 (2.92)	25.4 (1.00)
16	1"	207 Bar (3000 PSI)	114.0 (4.49)	63.5 (2.50)	22.4 (0.88)	24.4 (0.96)	65.8 (2.59)	177.8 (7.00)	125.7 (4.95)	87.4 (3.44)	29.0 (1.14)
20	1 1/4"	207 Bar (3000 PSI)	123.2 (4.85)	88.9 (3.50)	28.7 (1.13)	21.6 (0.85)	80.5 (3.17)	250.4 (9.86)	167.9 (6.61)	120.4 (4.74)	42.9 (1.69)
24	1 1/2"	207 Bar (3000 PSI)	136.4 (5.37)	88.9 (3.50)	35.1 (1.38)	25.1 (0.99)	85.6 (3.37)	250.4 (9.86)	169.9 (6.69)	105.9 (4.17)	38.1 (1.50)
32	2"	207 Bar (3000 PSI)	166.1 (6.54)	114.3 (4.50)	44.5 (1.75)	33.0 (1.30)	100.1 (3.94)	250.4 (9.86)	193.3 (7.61)	159.5 (6.28)	56.1 (2.21)

Ball Valve Seal Kits restore a ball valve to factory specifications, providing no erosion or metal-to-metal wear has taken place.

The Seal Kit includes all the o-rings, ball seals and thrust bearings that were originally installed at the factory. A sketch of these parts is provided at the right.

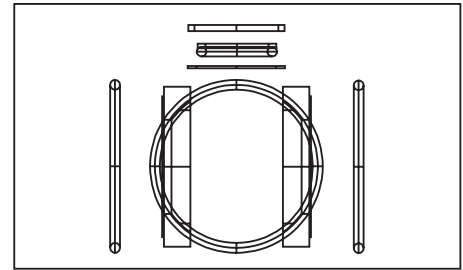

Ordering Information

SK	BV3D	<input type="checkbox"/>	<input type="checkbox"/>	<input type="checkbox"/>	<input type="checkbox"/>	<input type="checkbox"/>	<input type="checkbox"/>																																																		
Accessory	Series	Size	Ball Pattern	Ball Seals	Shaft Seals	Design Series	NOTE: Not required when ordering.																																																		
<table border="1" style="width: 100%; border-collapse: collapse;"> <thead> <tr> <th style="text-align: left;">Code</th> <th style="text-align: left;">Description</th> </tr> </thead> <tbody> <tr> <td>SK</td> <td>Seal Kit</td> </tr> </tbody> </table>		Code	Description	SK	Seal Kit	<table border="1" style="width: 100%; border-collapse: collapse;"> <thead> <tr> <th style="text-align: left;">Code</th> <th style="text-align: left;">Size</th> </tr> </thead> <tbody> <tr><td>04</td><td>1/4"</td></tr> <tr><td>06</td><td>3/8</td></tr> <tr><td>08</td><td>1/2"</td></tr> <tr><td>12</td><td>3/4"</td></tr> <tr><td>16</td><td>1"</td></tr> <tr><td>20</td><td>1 1/4"</td></tr> <tr><td>24</td><td>1 1/2"</td></tr> <tr><td>32</td><td>2"</td></tr> </tbody> </table>	Code	Size	04	1/4"	06	3/8	08	1/2"	12	3/4"	16	1"	20	1 1/4"	24	1 1/2"	32	2"	<table border="1" style="width: 100%; border-collapse: collapse;"> <thead> <tr> <th style="text-align: left;">Code</th> <th style="text-align: left;">Description</th> </tr> </thead> <tbody> <tr><td>1</td><td>Delrin</td></tr> <tr><td>2 *</td><td>PTFE</td></tr> <tr><td>4 †</td><td>Peek</td></tr> </tbody> </table> <p>* Valve pressure rating reduced. Consult factory. † Typically not available with Nitrile. Consult factory.</p>	Code	Description	1	Delrin	2 *	PTFE	4 †	Peek	<table border="1" style="width: 100%; border-collapse: collapse;"> <thead> <tr> <th style="text-align: left;">Code</th> <th style="text-align: left;">Description</th> </tr> </thead> <tbody> <tr><td>N</td><td>Nitrile</td></tr> <tr><td>V</td><td>Fluorocarbon</td></tr> <tr><td>E</td><td>EPR</td></tr> </tbody> </table>	Code	Description	N	Nitrile	V	Fluorocarbon	E	EPR	<table border="1" style="width: 100%; border-collapse: collapse;"> <thead> <tr> <th style="text-align: left;">Ball Code</th> <th style="text-align: center;">ISO Circuit Symbol</th> <th style="text-align: left;">Ball Pattern</th> </tr> </thead> <tbody> <tr> <td style="text-align: center;">1</td> <td style="text-align: center;"></td> <td>L-Bore Port Overlap</td> </tr> <tr> <td style="text-align: center;">2</td> <td style="text-align: center;"></td> <td>T-Bore 90°</td> </tr> <tr> <td style="text-align: center;">3</td> <td style="text-align: center;"></td> <td>T-Bore 180°</td> </tr> </tbody> </table>			Ball Code	ISO Circuit Symbol	Ball Pattern	1		L-Bore Port Overlap	2		T-Bore 90°	3		T-Bore 180°
Code	Description																																																								
SK	Seal Kit																																																								
Code	Size																																																								
04	1/4"																																																								
06	3/8																																																								
08	1/2"																																																								
12	3/4"																																																								
16	1"																																																								
20	1 1/4"																																																								
24	1 1/2"																																																								
32	2"																																																								
Code	Description																																																								
1	Delrin																																																								
2 *	PTFE																																																								
4 †	Peek																																																								
Code	Description																																																								
N	Nitrile																																																								
V	Fluorocarbon																																																								
E	EPR																																																								
Ball Code	ISO Circuit Symbol	Ball Pattern																																																							
1		L-Bore Port Overlap																																																							
2		T-Bore 90°																																																							
3		T-Bore 180°																																																							

BVHPLK: Standard Series 'BVHPLK-*' kit replaces the stopwasher with a stationary and moving plate, as illustrated below. As the handle is actuated, the moving plate aligns with one of the two locking positions in the stationary plate, enabling the valve to be locked in either **fully closed** or **fully open** position.

Insert padlock through both plates (here) to lock in CLOSED position.

Insert padlock through both plates (here) to lock in OPEN position.

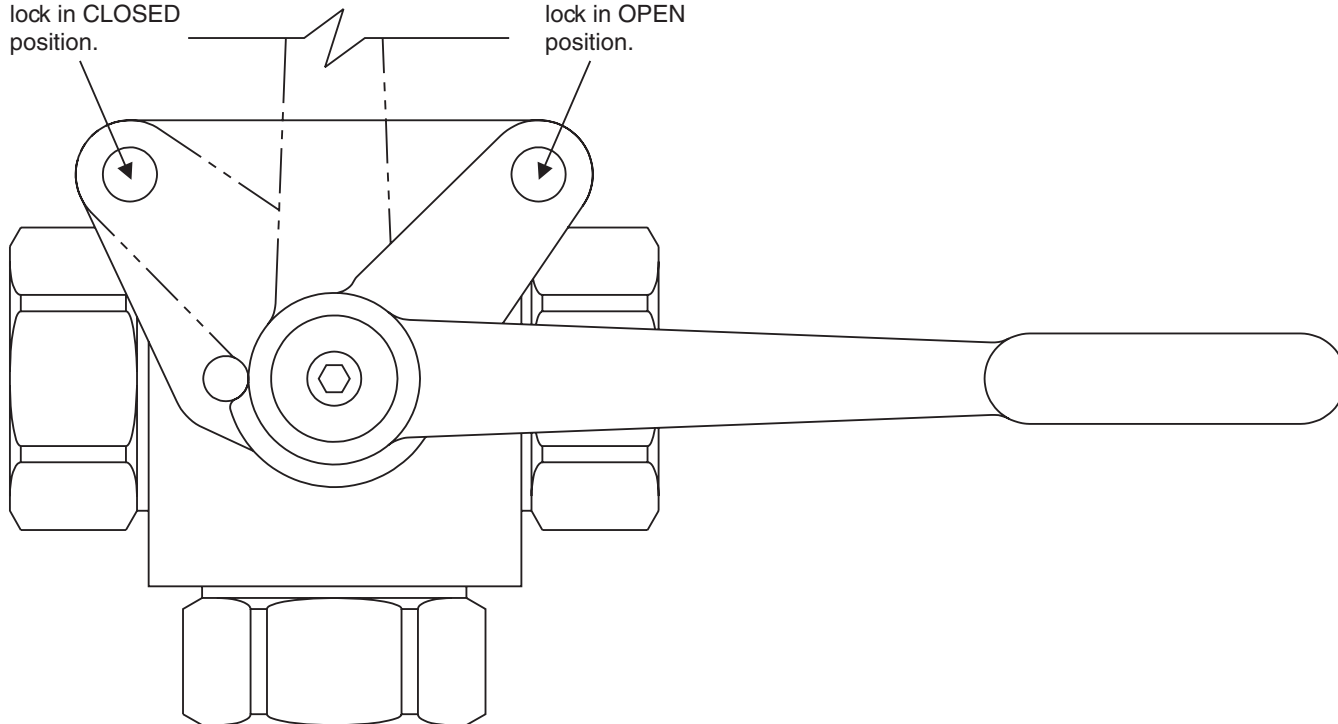

Ordering Information

BV3D Code	Size	Standard Locking (Part Number)
04	1/4"	BVHPLK-1
06	3/8"	BVHPLK-1
08	1/2"	BVHPLK-1
12	3/4"	BVHPLK-2
16	1"	BVHPLK-2
20	1 1/4"	BVHPLK-3
24	1 1/2"	BVHPLK-3
32	2"	BVHPLK-3

General Description

Series BV3H and BV4H are true 3-way and 4-way high pressure valves, incorporating many of the advanced features of the 2-way product. These products come in steel and are rated at 414 Bar (6000 PSI). Ports range from 1/4" to 2" with a variety of porting options.

Operation

Series BV3H operates by rotating the handle 90° and BV4H operates through 180° rotation of the handle, depending on the flow path. A BV4H with ball #4 is 90° operation.

Specifications

Maximum Pressure	414 Bar (6000 PSI)
Body Material	Carbon Steel, Black Oxide Stainless Steel
Ball Material	Steel, Chrome Plated, Trunnion mount
Standard Pattern	"L" Bore (3W), "T" Bore (4W)
Spindle Material	Steel, Zinc Plated
Standard Handle	T-Type Handle
Standard Ball Seals	Delrin + MoS ₂
Standard Shaft Seals	O-Ring & Bearing Stacks
Temperature Range with Standard Seals	-30°C to +100°C (-22°F to +212°F)

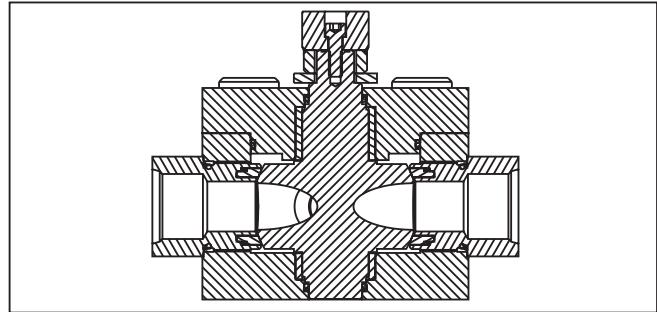
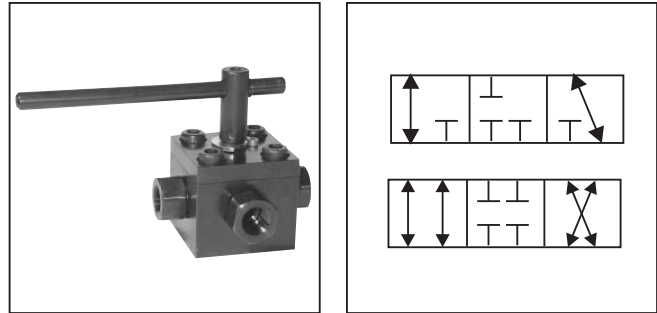

Features

- Three dimensional balanced sealing for near zero leakage in any circuit.
- The unique thrust bearing spindle design reduces actuation torque and reduces the chance of the valve seizing when inactive for periods of time.
- Special seal design enables high port to port ΔP application suitability.
- A variety of ball patterns allows flexibility in many applications.

Performance Curves

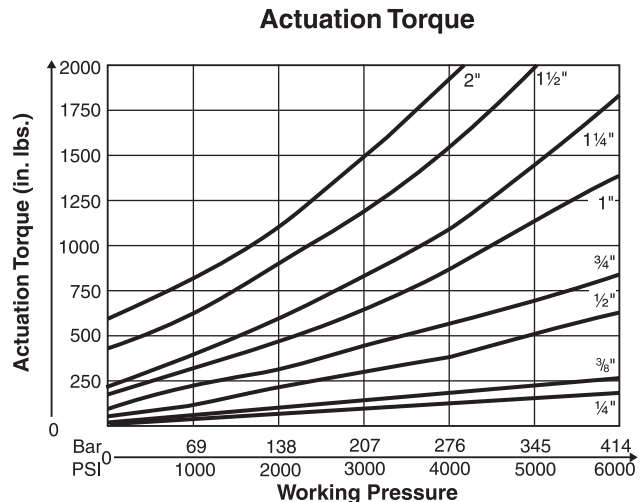
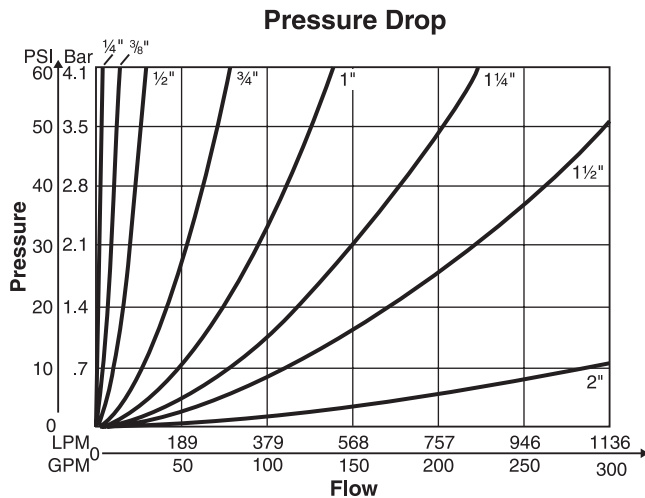

□	□	□	□	□	□	□	□	□	□	□	□
Series	Size	Port	Ball Pattern	Body Material	Ball & Stem Material	Ball Seals	Shaft Seals	Options	Design Series	NOTE: Not required when ordering.	

Code	Description
BV3H	3-Way
BV4H	4-Way

Code	Size
04	1/4"
06	3/8"
08	1/2"
12	3/4"
16	1"
20	1 1/4"
24	1 1/2"
32	2"

Code	Description
N	NPT Thread
S	SAE Thread
B	BSPP Thread

Code	Description
N	Nitrile
V	Fluorocarbon
E	EPR

Code	Description
Omit	No Options
A	Locking Handle
★C	1-Way Limit Switch
★K	1-Way Limit Switch w/Lock

★ When selecting this option, your ball valve will come with limit switch bracket, but does not include the switch. The switch is sold separately (Part #LSB)

Code	Description
1	Delrin
2 *	PTFE
4 †	Peek

* Valve pressure rating reduced. Consult factory.
 † Typically not available with Nitrile. Consult factory.

Code	Description
S	Steel
K	Stainless Steel

Code	Description
S	Steel
K	Stainless Steel

Weights

Code	BV3H		BV4H	
	kg	(lbs.)	kg	(lbs)
04	2.0	(4.5)	2.2	(4.75)
06	2.4	(5.25)	2.7	(6.0)
08	3.4	(7.5)	3.6	(8.0)
12	6.8	(15.0)	7.3	(16.0)
16	12.2	(27.0)	12.6	(27.75)
20	22.2	(49.0)	25.4	(56.0)
24	32.7	(72.0)	33.3	(73.5)
32	42.9	(94.5)	47.6	(105.0)

Multiway Manifold Mount Valve Porting Options

BV3H and BV4H valves are designed with no port-to-port overlap (see ISO symbols) during transition. See the table below to select the ball pattern ordering code.

Ball Code	ISO Circuit Symbol	Ball Pattern	Handle Phase					Stop Washer Type
			0°	45°	90°	135°	180°	
1		L-Bore 90° 3-Way Std.						
2		T-Bore 90° 3-Way Opt.						
3		T-Bore 180° 4-Way Std.						
4		X-Bore 90° 4-Way Opt.						

**Replacement Handles
 Standard Steel Offset**

Series	Part Number
BV*H04	BVH-HT1
BV*H06	BVH-HT1
BV*H08	BVH-HT1
BV*H12	BVH-HT2
BV*H16	BVH-HT2
BV*H20	BVH-HT3
BV*H24	BVH-HT3
BV*H32	BVH-HT3

Threaded Ports

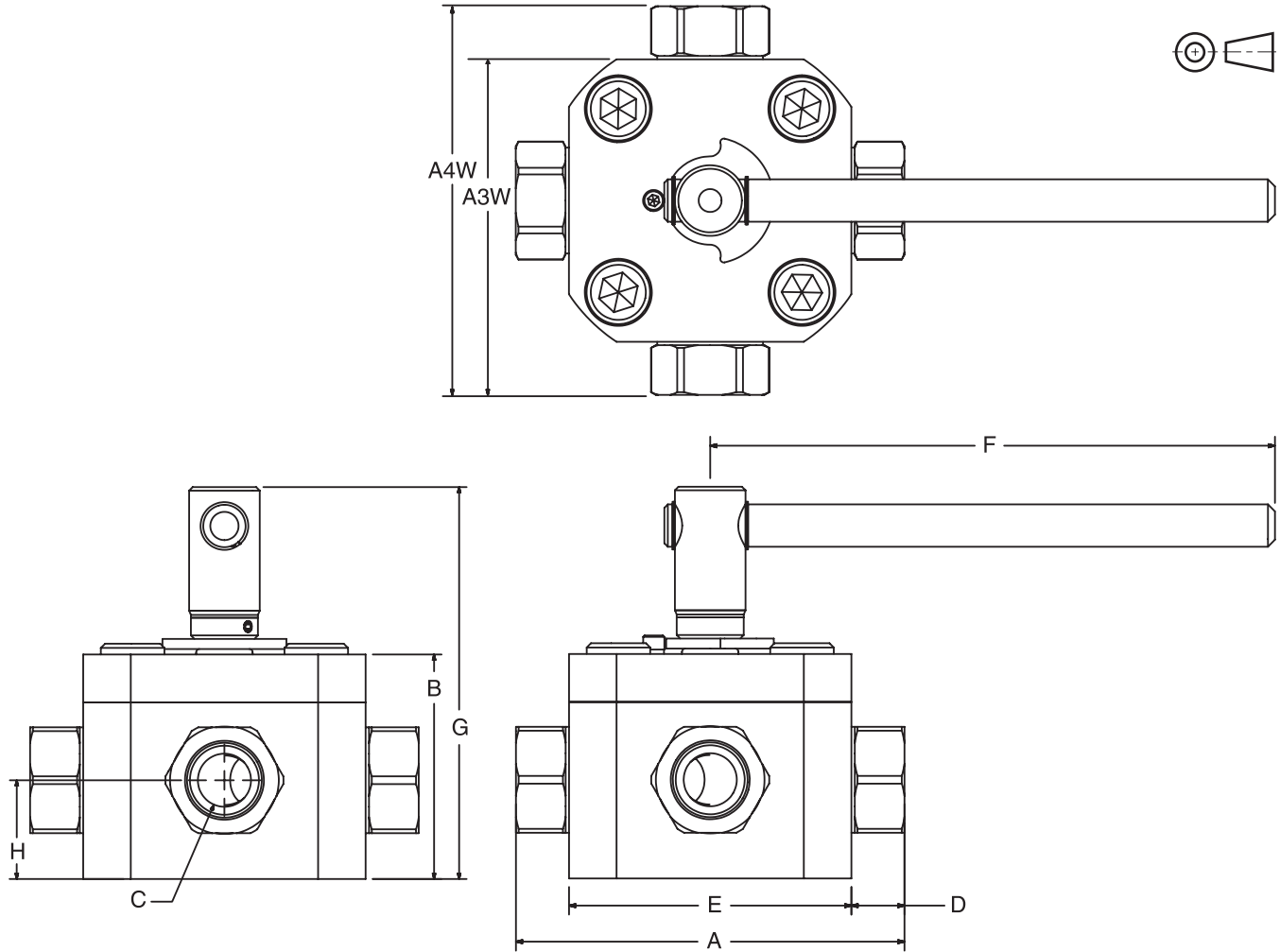

Code	Port Thread Size	Working Pressure	Dimensions mm (in)								
			A3W	A4W	B	C	D	E	F	G	H
BV3H/BV4H – NPT, SAE, and BSPP											
04	1/4"	414 Bar (6000 PSI)	78.2 (3.08)	90.4 (3.56)	64.3 (2.53)	7.9 (0.31)	12.2 (0.48)	63.5 (2.50)	177.8 (7.00)	122.2 (4.81)	31.0 (1.22)
06	3/8"	414 Bar (6000 PSI)	78.2 (3.08)	93.0 (3.66)	64.3 (2.53)	7.9 (0.31)	14.7 (0.58)	63.5 (2.50)	177.8 (7.00)	122.2 (4.81)	31.0 (1.22)
08	1/2"	414 Bar (6000 PSI)	95.5 (3.76)	115.1 (4.53)	69.9 (2.75)	11.2 (0.44)	19.9 (0.79)	76.2 (3.00)	177.8 (7.00)	129.0 (5.08)	33.8 (1.33)
12	3/4"	414 Bar (6000 PSI)	118.9 (4.68)	135.9 (5.35)	82.0 (3.23)	16.0 (0.63)	17.1 (0.68)	101.6 (4.00)	254.0 (10.00)	157.2 (6.19)	38.1 (1.50)
16	1"	414 Bar (6000 PSI)	150.9 (5.94)	174.8 (6.88)	101.1 (3.98)	22.4 (0.88)	23.9 (0.94)	127.0 (5.00)	254.0 (10.00)	176.3 (6.94)	50.8 (2.00)
20	1 1/4"	414 Bar (6000 PSI)	167.6 (6.60)	188.7 (7.43)	116.3 (4.58)	28.7 (1.13)	21.1 (0.83)	146.6 (5.77)	368.3 (14.50)	206.8 (8.14)	57.4 (2.26)
24	1 1/2"	414 Bar (6000 PSI)	209.3 (8.24)	234.2 (9.22)	129.0 (5.08)	33.3 (1.31)	25.0 (0.99)	184.2 (7.25)	368.3 (14.50)	219.5 (8.64)	58.9 (2.32)
32	2"	414 Bar (6000 PSI)	267.5 (10.53)	300.0 (11.81)	160.8 (6.33)	44.5 (1.75)	32.5 (1.28)	235.0 (9.25)	368.3 (14.50)	259.1 (10.20)	68.8 (2.71)

Ball Valve Seal Kits restore a ball valve to factory specifications, providing no erosion or metal-to-metal wear has taken place.

The Seal Kit includes all the o-rings, ball seals and thrust bearings that were originally installed at the factory. A sketch of these parts is provided at the right.

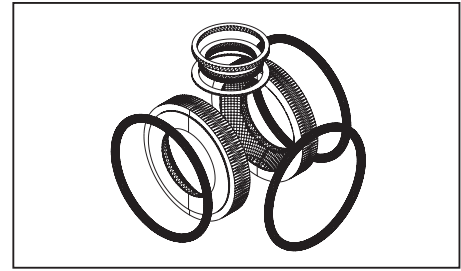

Ordering Information

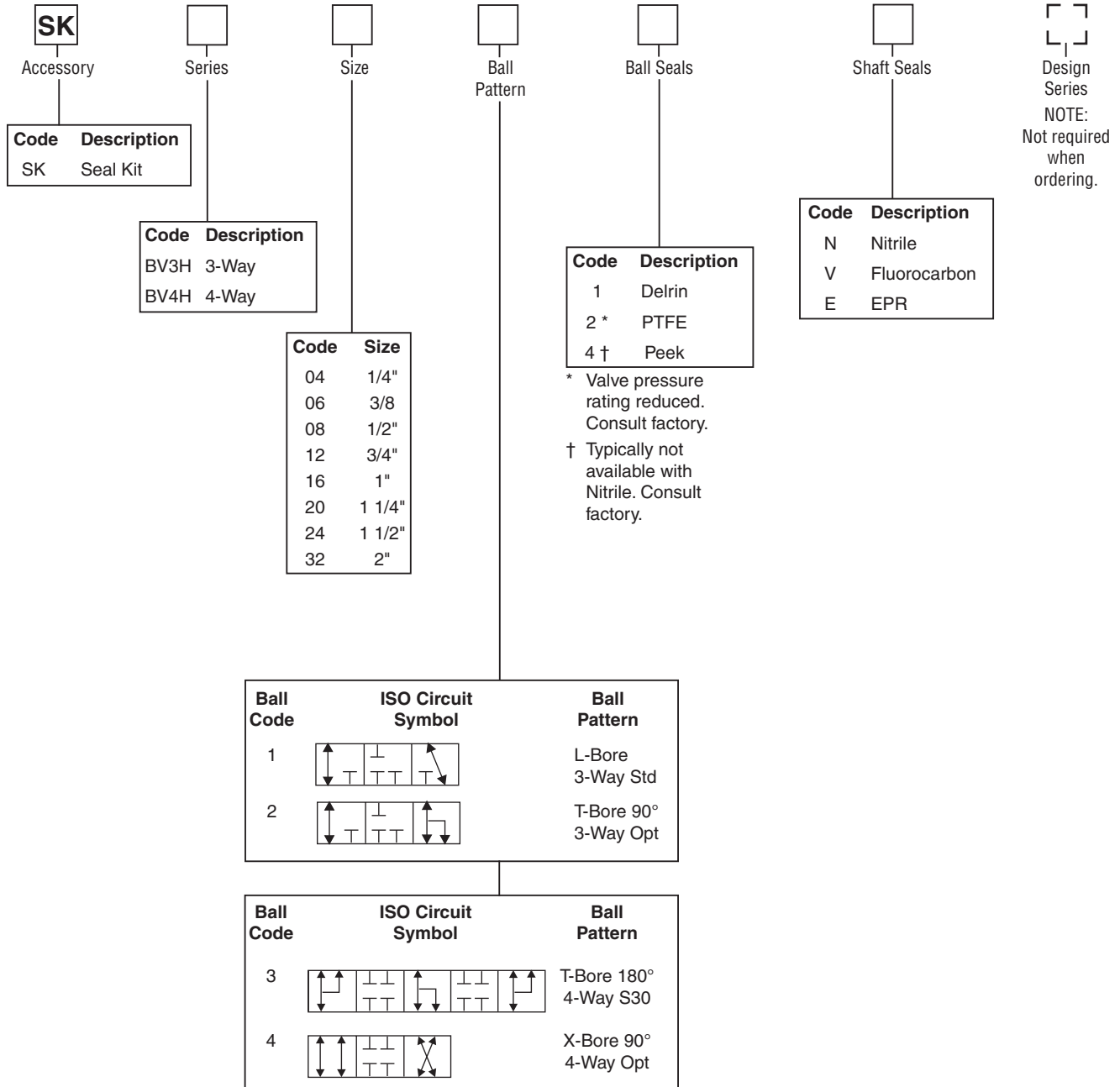

General Description

Series BVMM is a manifold mounted high pressure 414 Bar (6000 PSI) 2 or 3-way ball valve. Manifold mounting eliminates an external fluid connection.

Operation

Series BVMM valves operate through either 90° or 180° depending on the ball pattern chosen. For 3-way valves, pressure is applied to Port 1.

Specifications

Maximum Pressure	414 Bar (6000 PSI)
Body Material	Carbon Steel, Black Oxide
Ball Material	Steel, Chrome Plated
Spindle Material	Steel, Nickel Plated
Standard Handle	Steel Offset, Nickel Plated
Standard Ball Seals	Delrin + MoS ₂
Standard Shaft Seals	O-Ring & Backup, Nitrile
Temperature Range with Standard Seals	-30°C to +100°C (-22°F to +212°F)

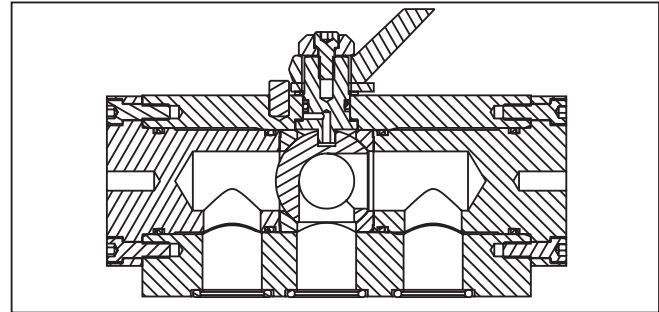
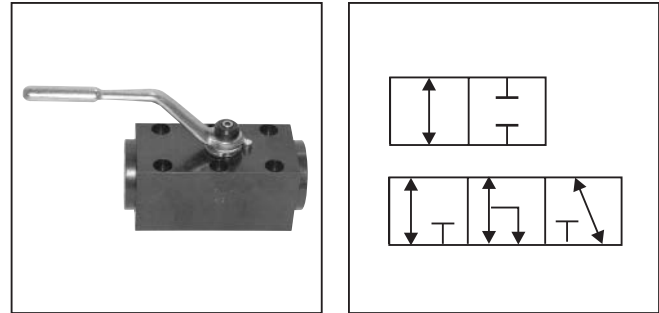

Features

- Variety of ball patterns allow for different flow paths and flexibility for many applications.
- Thrust bearings in the spindle and delrin moly ball seals result in low actuation torque as well as extended service life.

Performance Curves

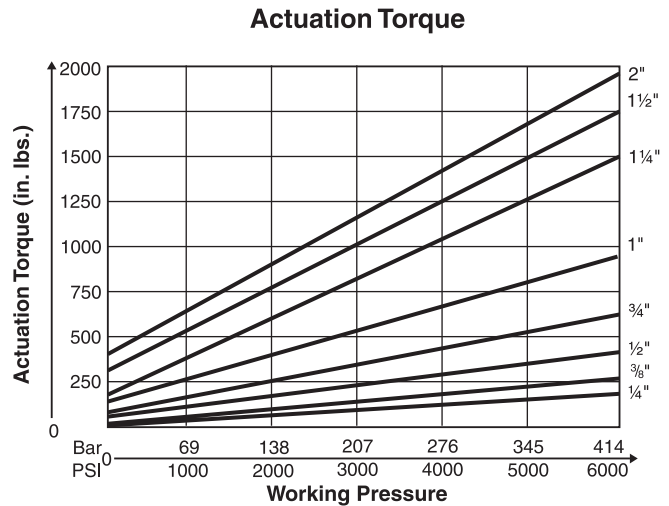
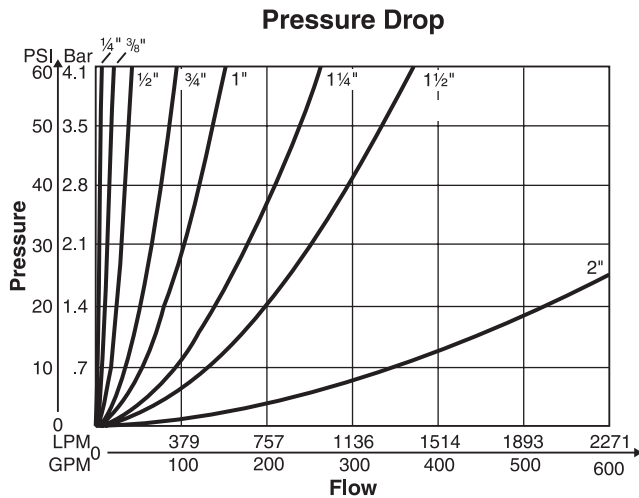

BVMM Series	<input type="checkbox"/> Size	<input type="checkbox"/> Ball Pattern	S Body Material	S Ball & Stem Material	<input type="checkbox"/> Ball Seals	<input type="checkbox"/> Shaft Seals	<input type="checkbox"/> Options	<input type="checkbox"/> Design Series NOTE: Not required when ordering.
-----------------------	----------------------------------	--	---------------------------	----------------------------------	--	---	-------------------------------------	---

Code	Size
04	1/4"
06	3/8
08	1/2"
12	3/4"
16	1"
20	1 1/4"
24	1 1/2"
32	2"

Code	Description
N	Nitrile
V	Fluorocarbon
E	EPR

Code	Description
1	Delrin
2 *	PTFE
4 †	Peek

* Valve pressure rating reduced. Consult factory.
† Typically not available with Nitrile. Consult factory.

Code	Description
S	Steel

Code	Description
S	Steel

Code	Description
Omit	No Options
A	Locking Handle
★C	1-Way Limit Switch
G **	Flat Non-offset Handle
★*K	1-Way Limit Switch w/Lock

* Switch is set to indicate valve open condition
★ When selecting this option, your ball valve will come with limit switch bracket, but does not include the switch. The switch is sold separately (Part #LSB)
** Cannot be combined with other options.

Code	kg	(lbs.)
04	1.1	(2.5)
06	1.9	(4.25)
08	2.3	(5.0)
12	5.2	(11.5)
16	7.9	(16.5)
20	15.0	(33.0)
24	25.4	(56.0)
32	33.3	(73.5)

Multiway Manifold Mount Valve Porting Options

Ball Code	ISO Circuit Symbol	Ball Pattern	Handle Phase					Stop Washer Type
			0°	45°	90°	135°	180°	
1		2-Way						
2		L-Bore Port Overlap						
3		L-Bore 180°						
4		T-Bore 90°						
5		T-Bore 180°						

Replacement Handles Standard Steel Offset

Series	Part Number
BVMM04	BVH-HS1
BVMM06	BVH-HS1
BVMM08	BVH-HS1
BVMM12	BVH-HS2
BVMM16	BVH-HS2
BVMM20	BVH-HS3
BVMM24	BVH-HS3
BVMM32	BVH-HS3

Please request a certified print before building a manifold.

For 3-way valves, pressure is applied to Port 1.

Manifold Mounted

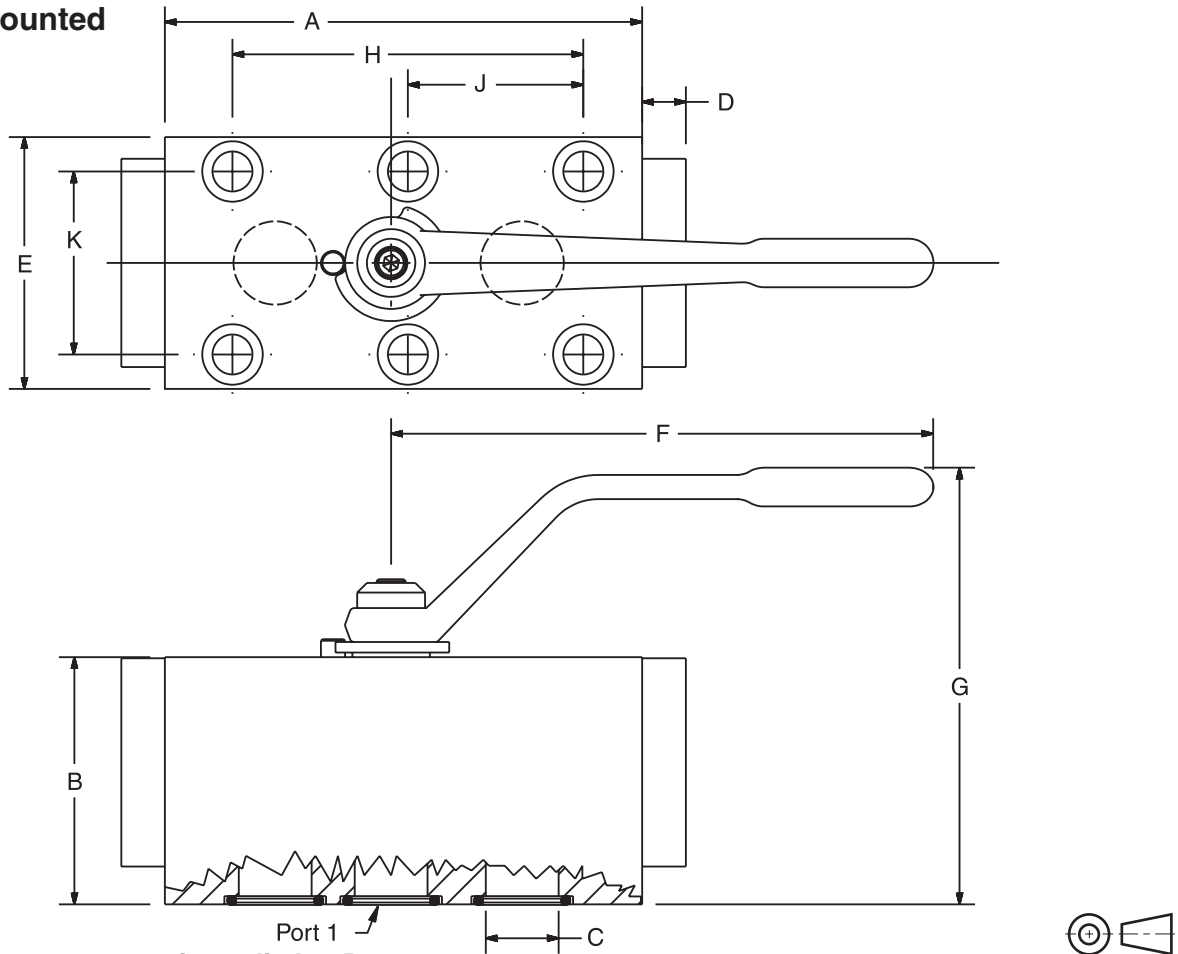

**For 3-way valves, pressure is applied to Port 1.
Please request a certified print before building a manifold.**

Code	Port Thread Size	Working Pressure	Dimensions mm (in)									
			A	B	C	D	E	F	G	H	J	K
BVMM – 2-Way and 3-Way Manifold Mounted												
04	1/4"	414 Bar (6000 PSI)	63.5 (2.50)	38.1 (1.50)	6.1 (0.24)	11.2 (0.44)	50.8 (2.00)	114.3 (4.50)	79.2 (3.12)	41.99 (1.653)	N/A	35.0 (1.377)
06	3/8"	414 Bar (6000 PSI)	81.8 (3.22)	43.7 (1.72)	9.7 (0.38)	11.2 (0.44)	57.2 (2.25)	114.3 (4.50)	85.1 (3.35)	54.99 (2.165)	N/A	40.0 (1.574)
08	1/2"	414 Bar (6000 PSI)	100.3 (3.95)	50.8 (2.00)	13.0 (0.51)	10.9 (0.43)	57.2 (2.25)	114.3 (4.50)	91.9 (3.62)	82.99 (3.267)	41.5 (1.633)	45.0 (1.770)
12	3/4"	414 Bar (6000 PSI)	132.3 (5.21)	69.9 (2.75)	20.1 (0.79)	10.9 (0.43)	69.9 (2.75)	177.8 (7.00)	132.8 (5.23)	96.98 (3.818)	48.5 (1.909)	51.0 (2.008)
16	1"	414 Bar (6000 PSI)	148.6 (5.85)	82.6 (3.25)	23.9 (0.94)	14.2 (0.56)	82.6 (3.25)	177.8 (7.00)	145.5 (5.73)	115.01 (4.528)	57.5 (2.264)	60.0 (2.362)
20	1 1/4"	414 Bar (6000 PSI)	177.8 (7.00)	95.3 (3.75)	31.8 (1.25)	16.0 (0.63)	101.6 (4.00)	250.4 (9.86)	176.3 (6.94)	135.99 (5.354)	68.0 (2.677)	78.0 (3.070)
24	1 1/2"	414 Bar (6000 PSI)	189.2 (7.45)	100.1 (3.94)	38.1 (1.50)	19.1 (0.75)	127.0 (5.00)	250.4 (9.86)	181.6 (7.15)	111.99 (4.409)	55.9 (2.199)	95.0 (3.740)
32	2"	414 Bar (6000 PSI)	231.1 (9.10)	120.7 (4.75)	47.8 (1.88)	22.1 (0.87)	152.4 (6.00)	250.4 (9.86)	200.9 (7.91)	135.99 (5.354)	68.2 (2.684)	112.0 (4.410)

NOTES: (1) These sizes use only the four outside mounting holes. Dimension J is not applicable.
 (2) Ball portings for multiway valves are smaller than their 2-way counterparts in some sizes.
 Please refer to dimension C to confirm suitability.

3300-ballvalves.indd, ddp

Manifold Porting Specifications

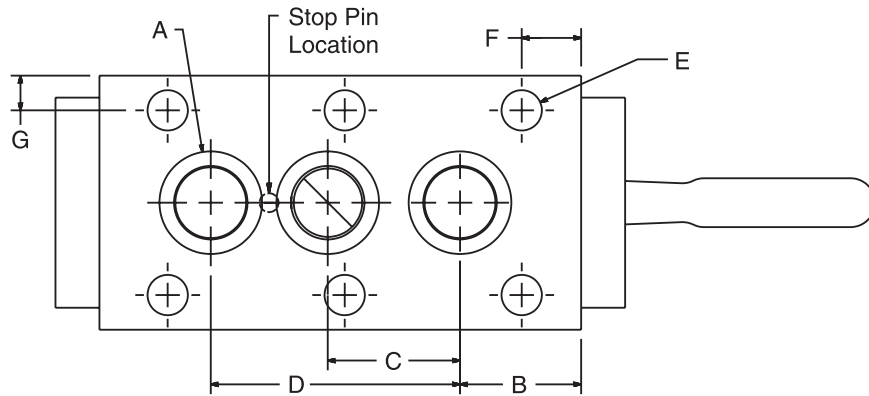

For 3-way valves, pressure is applied to Port 1.
Please request a certified print before building a manifold.

Code	Port Thread Size	Dimensions mm (in)						
		A	B	C	D	E	F	G
BVMM – Mounting Pad Specifications								
04	1/4"	12.70 (0.500)	16.31 (0.642)	21.97 (0.865)	38.99 (1.535)	8.89 (0.350)	15.54 (0.612)	7.92 (0.312)
06	3/8"	15.88 (0.625)	21.84 (0.860)	24.94 (0.982)	43.99 (1.732)	8.89 (0.350)	19.56 (0.770)	8.59 (0.338)
08	1/2"	19.05 (0.750)	24.05 (0.947)	26.42 (1.040)	57.99 (2.283)	8.89 (0.350)	7.44 (0.293)	6.10 (0.240)
12	3/4"	27.00 (1.063)	40.49 (1.594)	30.73 (1.210)	68.99 (2.716)	10.41 (0.410)	22.66 (0.892)	9.42 (0.371)
16	1"	33.35 (1.313)	39.34 (1.549)	38.00 (1.496)	80.98 (3.188)	12.95 (0.510)	19.30 (0.760)	11.28 (0.444)
20	1 1/4"	39.70 (1.563)	40.13 (1.580)	45.97 (1.810)	96.01 (3.780)	13.11 (0.516)	17.17 (0.676)	11.81 (0.465)
24	1 1/2"	47.63 (1.875)	42.19 (1.661)	56.13 (2.210)	111.99 (4.409)	16.66 (0.656)	42.19 (1.661)	16.00 (0.630)
32	2"	57.15 (2.250)	55.30 (2.177)	67.82 (2.670)	135.99 (5.354)	21.08 (0.830)	112.01 (4.410)	20.19 (0.795)

Ball Valve Seal Kits restore a ball valve to factory specifications, providing no erosion or metal-to-metal wear has taken place.

The Seal Kit includes all the o-rings, ball seals and thrust bearings that were originally installed at the factory. A sketch of these parts is provided at the right.

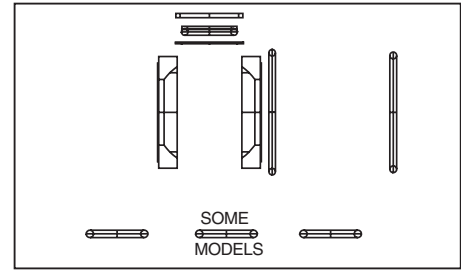

Ordering Information

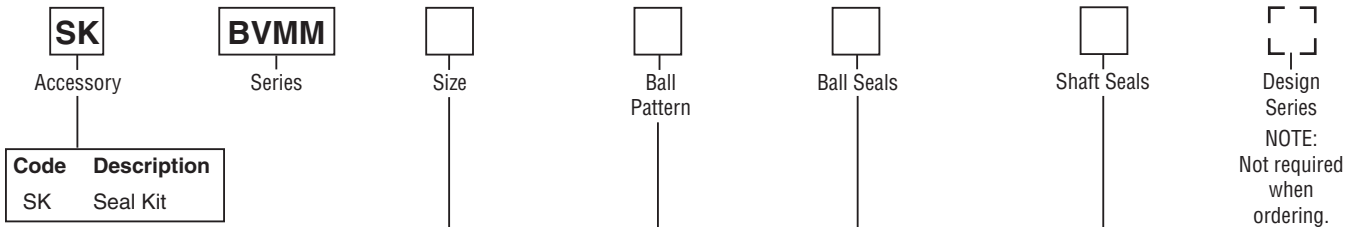

Code	Description
SK	Seal Kit

Code	Size
04	1/4"
06	3/8"
08	1/2"
12	3/4"
16	1"
20	1 1/4"
24	1 1/2"
32	2"

Code	Description
1	Delrin
2 *	PTFE
4 †	Peek

* Valve pressure rating reduced. Consult factory.
 † Typically not available with Nitrile. Consult factory.

Code	Description
N	Nitrile
V	Fluorocarbon
E	EPR

Ball Code	ISO Circuit Symbol	Ball Pattern
1		2-Way

Ball Code	ISO Circuit Symbol	Ball Pattern
2		L-Bore Port Overlap
3		L-Bore 180°
4		T-Bore 90°
5		T-Bore 180°

BVMM2LK: Standard Series 'BVMM2LK-*' kit replaces the stopwasher with a stationary and moving plate, as illustrated below. As the handle is actuated, the moving plate aligns with one of the two locking positions in the stationary plate, enabling the valve to be locked in either **fully closed** or **fully open** position.

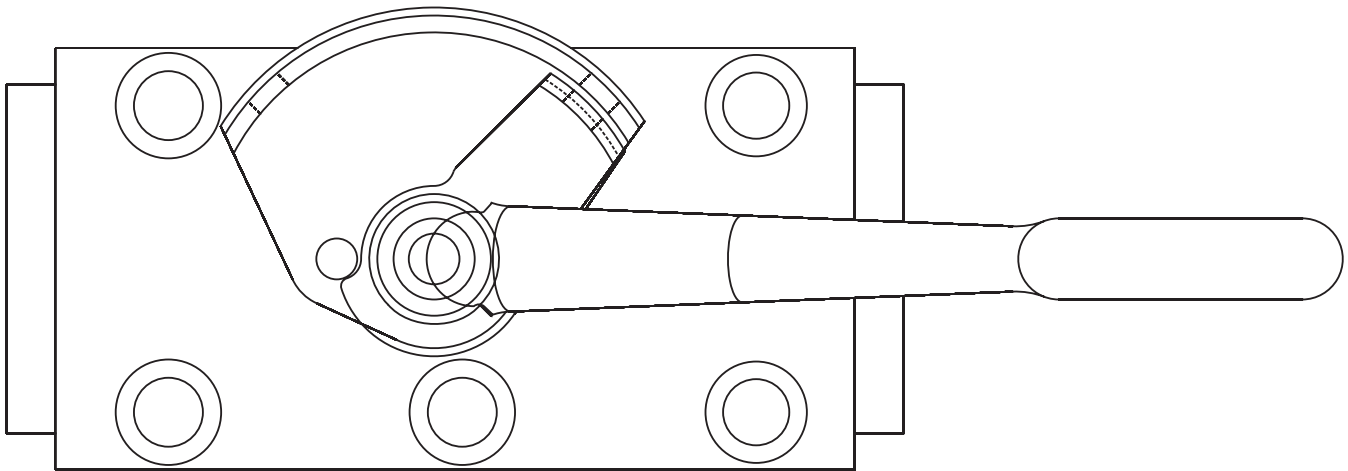

Ordering Information

BVMM		Standard Locking
Code	Size	(Part Number)
04	1/4"	BVDMLH-1
06	3/8"	BVDMLH-1
08	1/2"	BVDMLH-1
12	3/4"	BVDMLH-2
16	1"	BVDMLH-2
20	1 1/4"	BVDMLH-3
24	1 1/2"	BVDMLH-3
32	2"	BVDMLH-3

General Description

Series BVAL ball valves are designed to meet the needs of suction line and low pressure applications. This series is available from 1/4" to 4" ports NPT, SAE and BSPP, and is designed to assure leak free hydraulic suction and return line durability.

Operation

Parker's 2-way ball valves operate to either off or full flow by rotating the handle 90°. Ball valves are not designed to be a metering or flow control device.

Specifications

Maximum Pressure	28 Bar (400 PSI)
Body Material	Aluminum
Ball Material	Brass, Chrome Plated
Stem Material	Brass, Oversize Bearing Area
Standard Handle	Aluminum Offset
Standard Ball Seals	PTFE standard
Standard Shaft Seals	O-Ring & Backup, Nitrile
Temperature Range with Standatd Seals	-30°C to +100°C (-22°F to +212°F)

Features

- Unrestricted bore from 1/4" to 4".
- Unrestricted flow and cavitation eliminated.
- Availability of NPT, BSPP and SAE O-ring sealed ports assure leak-free service.
- Choice of optional seal materials allows use with phosphate esters, water glycols and other media.
- Utilizes top grade PTFE ball seats with O-ring seals throughout to assure smooth and leak-free operation.

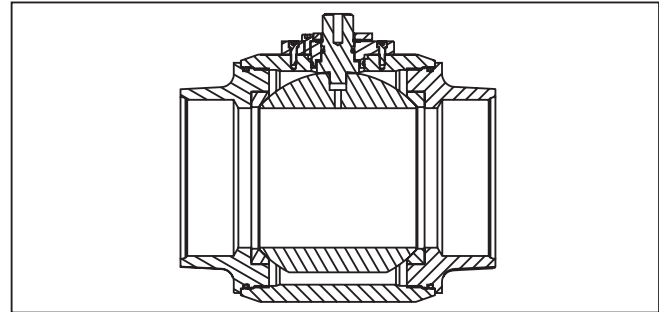
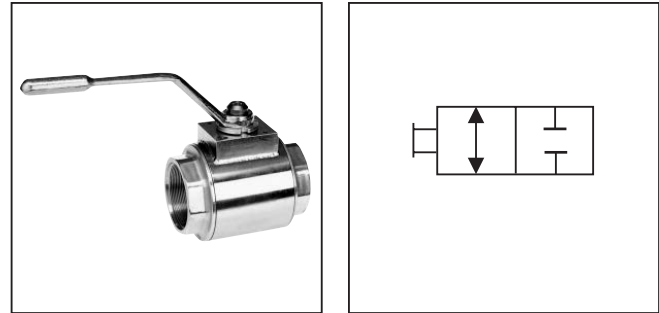

Performance Curves

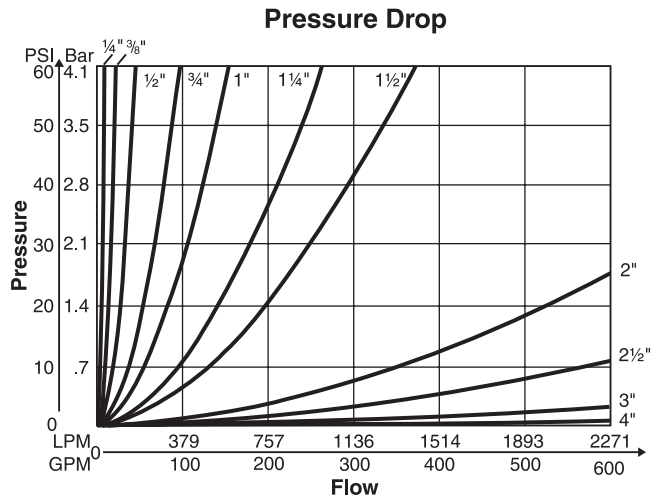

Actuation Torque

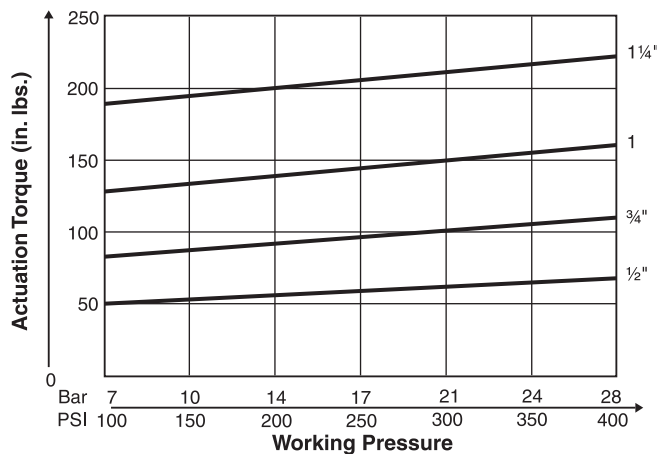

Actuation Torque

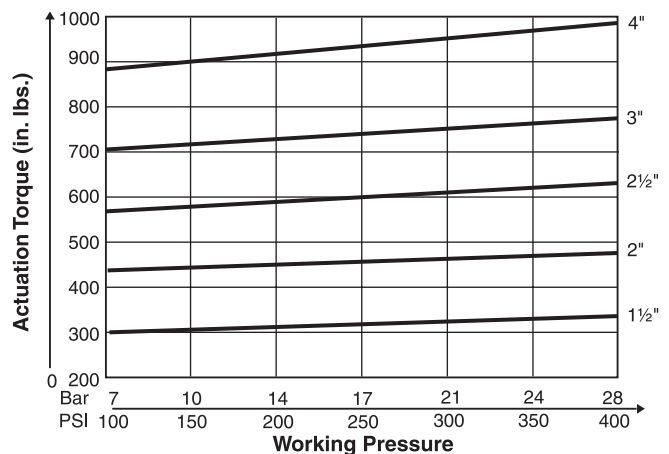

BVAL	□	□	S	S	2	□	□	□ □ □ □
Series	Size	Port	Body Material	Ball & Stem Material	Ball Seals	Shaft Seals	Options	Design Series NOTE: Not required when ordering.

Code	Size
04	1/4"
06	3/8"
08	1/2"
12	3/4"
16	1"
20	1 1/4"
24	1 1/2"
32	2"
40	2 1/2"
48	3"
64	4"

Code	Description
N	NPT Thread
S	SAE Thread
B	BSPP Thread
U	ISO 6149 Thread

Code	Description
N	Nitrile
V	Fluorocarbon
E	EPR

Code	Description
2	PTFE

Code	Description
S	Aluminum

Code	Description
S	Brass

Code	Description
Omit	No Options
A	Locking Handle
B	Security Locking Handle
★C	1-Way Limit Switch
D	2-Way Limit Switch
*E	Panel Mount
G	Flat Non-offset Handle
★★K	1-Way Limit Switch w/Lock
★L	2-Way Limit Switch w/Lock

* Cannot be combined with other options

** Switch is set to indicate valve open condition

★ When selecting this option, your ball valve will come with limit switch bracket, but does not include the switch. The switch is sold separately (Part #LSB)

Code	Weight kg (lbs.)	Code	Weight kg (lbs.)	Code	Weight kg (lbs.)
4	0.2 (0.5)	16	0.5 (1.0)	40	3.5 (7.75)
6	0.2 (0.5)	20	0.8 (1.75)	48	4.8 (10.5)
8	0.2 (0.5)	24	1.1 (2.5)	64	7.4 (16.25)
12	0.3 (0.75)	32	1.8 (4.0)		

Seal Kit Accessories

Ball Valve Seal Kits restore a ball valve to factory specifications, providing no erosion or metal-to-metal wear has taken place.

The Seal Kit includes all the o-rings, ball seals and thrust bearings that were originally installed at the factory. A sketch of these parts for most 2-way valves is provided at the right.

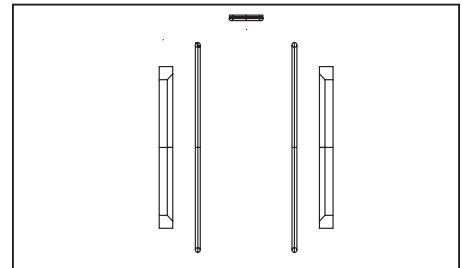

Ordering Information

SK	BVAL	□	2	□	□ □ □ □
Accessory	Series	Size	Ball Seals	Shaft Seals	Design Series NOTE: Not required when ordering.

Code	Description
SK	Seal Kit

Code	Size
04	1/4"
06	3/8"
08	1/2"
12	3/4"
16	1"
20	1 1/4"
24	1 1/2"
32	2"
40	2 1/2"
48	3"
64	4"

Code	Description
2	PTFE

Code	Description
N	Nitrile
V	Fluorocarbon
E	EPR

Threaded Ports

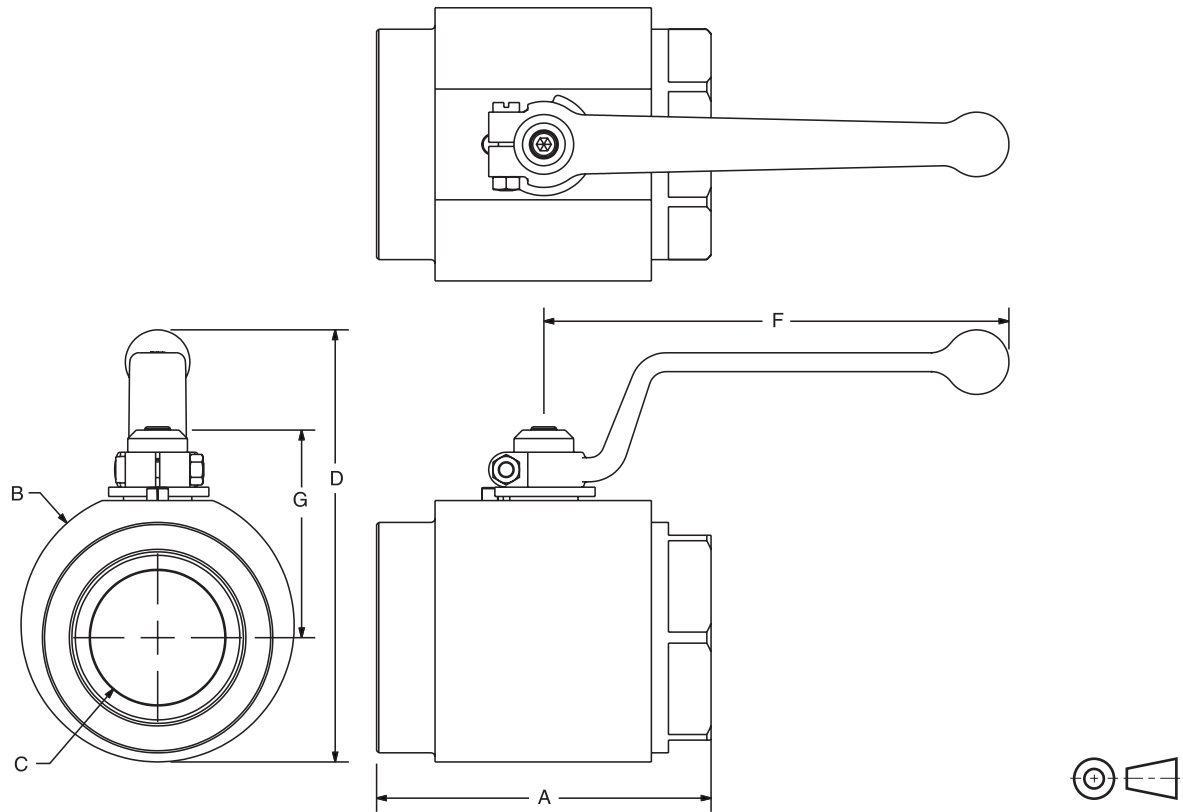

Code	Port Thread Size	Working Pressure	Dimensions mm (in)					
			A	B	C	D	F	G
BVAL – NPT, SAE, and BSPP								
04	1/4"	28 Bar (400 PSI)	66.8 (2.63)	38.1 (1.50)	6.4 (0.25)	68.6 (2.70)	85.1 (3.35)	41.4 (1.63)
06	3/8"	28 Bar (400 PSI)	66.8 (2.63)	38.1 (1.50)	9.7 (0.38)	68.6 (2.70)	85.1 (3.35)	41.4 (1.63)
08	1/2"	28 Bar (400 PSI)	66.8 (2.63)	38.1 (1.50)	12.7 (0.50)	68.6 (2.70)	85.1 (3.35)	41.4 (1.63)
12	3/4"	28 Bar (400 PSI)	83.3 (3.28)	44.5 (1.75)	19.1 (0.75)	95.8 (3.77)	129.3 (5.09)	47.2 (1.86)
16	1"	28 Bar (400 PSI)	88.4 (3.48)	50.8 (2.00)	25.4 (1.00)	101.9 (4.01)	129.3 (5.09)	50.3 (1.98)
20	1 1/4"	28 Bar (400 PSI)	99.1 (3.90)	69.9 (2.75)	31.8 (1.25)	131.8 (5.19)	173.0 (6.81)	64.3 (2.53)
24	1 1/2"	28 Bar (400 PSI)	109.7 (4.32)	82.6 (3.25)	38.1 (1.50)	143.5 (5.65)	173.0 (6.81)	69.6 (2.74)
32	2"	28 Bar (400 PSI)	124.5 (4.90)	101.6 (4.00)	50.8 (2.00)	162.8 (6.41)	173.0 (6.81)	78.0 (3.07)
40	2 1/2"	28 Bar (400 PSI)	152.4 (6.00)	127.0 (5.00)	63.5 (2.50)	203.2 (8.00)	218.7 (8.61)	104.4 (4.11)
48	3"	28 Bar (400 PSI)	185.7 (7.31)	152.4 (6.00)	76.2 (3.00)	228.3 (8.99)	218.7 (8.61)	116.3 (4.58)
64	4"	28 Bar (400 PSI)	225.8 (8.89)	177.8 (7.00)	101.6 (4.00)	254.3 (10.01)	218.7 (8.61)	129.8 (5.11)

BVHPLK: Standard Series 'BVHPLK-*' kit replaces the stopwasher with a stationary and moving plate, as illustrated below. As the handle is actuated, the moving plate aligns with one of the two locking positions in the stationary plate, enabling the valve to be locked in either **fully closed** or **fully open** position.

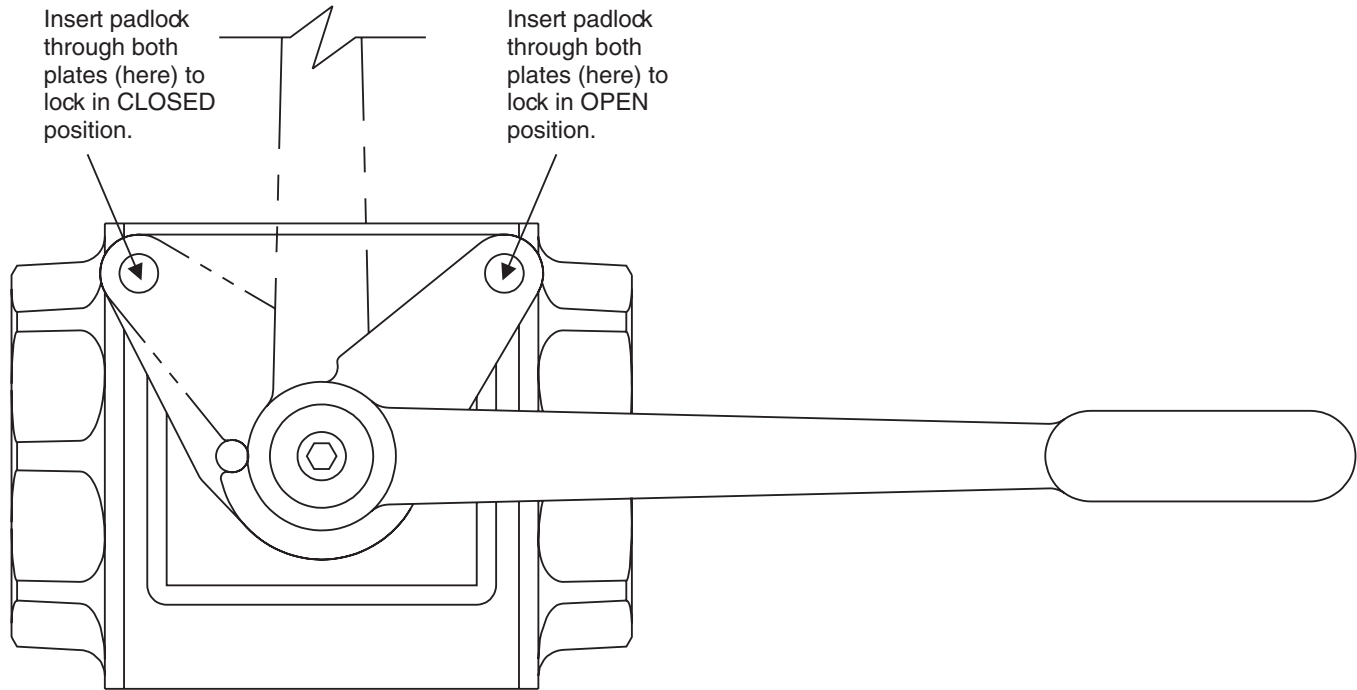

Ordering Information

BVAL		Standard Locking
Code	Size	(Part Number)
04	1/4"	BVHPLK-1
06	3/8"	BVHPLK-1
08	1/2"	BVHPLK-1
12	3/4"	BVHPLK-1
16	1"	BVHPLK-1
20	1 1/4"	BVHPLK-2
24	1 1/2"	BVHPLK-2
32	2"	BVHPLK-2
40	2 1/2"	BVHPLK-3
48	3"	BVHPLK-3
64	4"	BVHPLK-3

Ball Valve Sizing Chart (2-Way)

Parker's unrestricted bore ball valves provide a fluid path which, in most cases, imposes no discernable pressure drop in standard hydraulic circuits. As a result, you can treat our valves as just like a length of fluid line, unless you are working with closed loop or other circuits where a tiny pressure drop carries a price tag in heat generation, etc.

The selection chart at the right may be used as a guide for confirming your choice of ball valve fluid line size relative to the expected flow in LPM (GPM) at a given velocity.

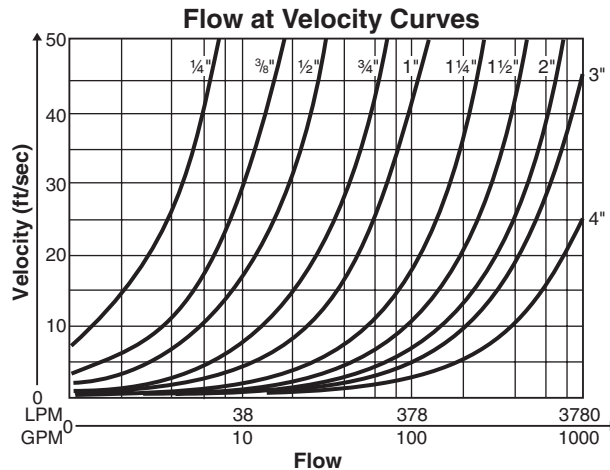

Ball Seals and Internal O-Rings

Standard Ball Seal Materials: Most application needs can be met by specifying one of the following ball seal materials:

- **Delrin™ Moly:** Standard with most ball valves. High pressure, moderate temperature range.
- **PTFE:** Excellent for suction and low pressure use. Inert to most substances and safe for food/water use.
- **Peek Hi-Temp:** Cost effective, provides additional temperature range up to 176.7°C (350°F). Best results with fluorocarbon sealing.

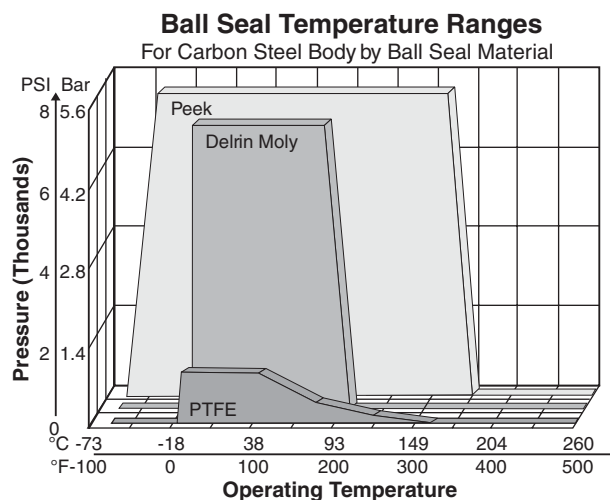

O-Ring and Backup Ring Material

- **Nitrile:** The industry standard for hydraulics using petroleum based fluids. Not suitable above 100°C (212°F).
- **EPR:** For use with Phosphate Esters ("Skydrol"), strong acids and bases, and other hostile media. Not compatible with petroleum based fluids. Good temperature range.
- **Fluorocarbon:** Extends temperature range to 350°F (176.7°C) with most Nitrile compatible media. Somewhat resistant to hostile media.

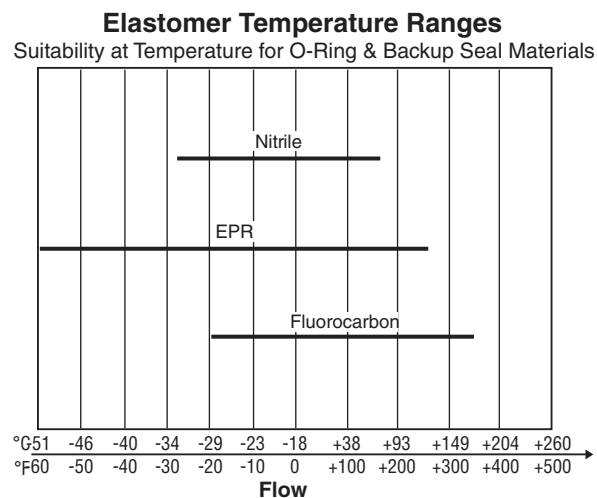

Sealing Materials Technical Data

Never operate Parker Ball Valves outside the temperature range published below for your selected thermoplastic and elastomer materials, even if the combination is approved in the Media Acceptability Table. You may experience valve leakage or failure.

Order Code	Ball Seal Materials			O-Ring & Backup Seal Materials		
	1	2	4	N	E	V
Description	Delrin™ Moly	PTFE	PEEK Hi-Temp	Nitrile	EPR	Fluorocarbon
Temperature Range	-30°C to +100°C (-22°F to +212°F)	-60°C to +180°C (-76°F to +356°F)	-40°C to +250°C (-40°F to +482°F)	-30°C to +100°C (-22°F to +212°F)	-50°C to +150°C (-58°F to +302°F)	-25°C to +250°C (-13°F to +482°F)
Seal Compound Identification	Delrin+MoS ₂ Polyoxymethylene impregnated with Molybdenum Disulphide	Polytetra- fluoroethylene	Polyether-ether- ketone	Nitrile Butadiene rubber	Ethylene- polypropylene- diene rubber	Fluoropropylene methylene
Acronym	DM	PTFE	PEEK	NBR	EPR EPDM	FPM
Classification Synthesis	Thermoplast Saturated heteropolymer of heterogeneous polymer chains compounded with sulphide of molyb- denum metal for lubrication	Thermoplast Homogeneous, pure polymer chains, contain- ing fluorine	Thermoplast Aromatic linear polymer	Elastomer Unsaturated heteropolymer compounded from acrylonitrile and butadiene	Elastomer Saturated heteropolymer utilizing double valence bands outside the primary chain	Elastomer Multiple monomers & fluorine com- pounded into saturated hetero- polymer
Commercial Trade Names	Made to Parker's specifications	PTFE Hostafion Fluon	Victrex	Nitrile Perbunan Chemigum Elaprim Krynac	Buna AP Dutral Epcar Keltran Nordel	Viton Fluorel Technoflon
Chemical Resistance Examples						
Suitable	Hydraulic fluids Water Inert Gases Air Alcohols Glycols Petroleum based fluids	Foodstuffs Acids & Alkalis Organic & inorganic solvents	Most fluids acceptable with Delrin Moly	Hydraulic fluids (except Skydrol) Water Air Petroleum based fluids	Phosphate esters Brake fluid Acids & Alkalis	NBR compatible fluids Acids & Alkalis
Not suitable	High molar acids & alkalis Fluorines Liquids for human consumption	Fluorines Liquid alkali metals	High molar acids & alkalis	Phosphate esters	Petroleum based oil & grease Chlorinated hydrocarbons	Phosphate esters

General Description

Series 500 low pressure ball valves provide total shut-off capability for services up to 41 Bar (600 PSI). Series 500 consists of NPT female/female ports, Series 510 and 501 are male/female in SAE and NPT respectively, and Series 506 are female/female in SAE. Series 502 features panel mounting capability.

Operation

A quarter turn of the handle is on or off. Ball valves are not intended for use as a throttling valve. Attempting to use it in these applications may result in premature seal failure and/or inability to turn the valve handle.

Features

- Ball valve bodies are machined from high quality CA377 forgings which provide extended service life and resist failure caused by severe temperature conditions.
- Highly inert PTFE seats and seals provide resistance to chemical corrosion.
- Blowout proof stem design, chrome plated brass ball and a special design handle enable increased turn and leverage for ease of opening and closing.
- Padlocking handle option provides lock-out capability where required.
- Venting option relieves downstream pressure in pneumatic applications.

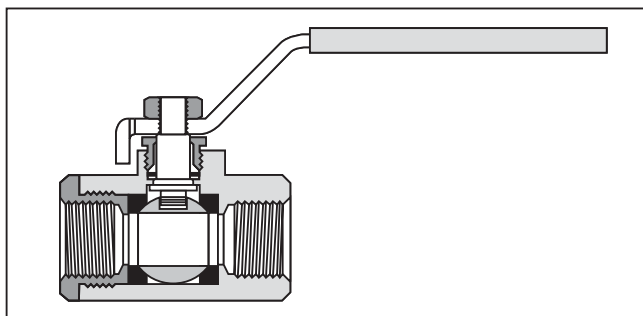
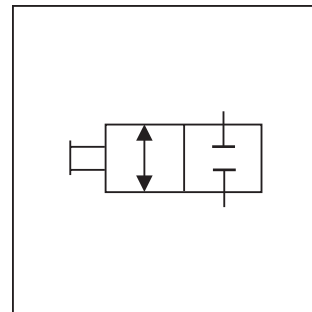

Specifications

Maximum Working Pressure	41 Bar (600 PSI) Vented up to 17 Bar (250 PSI) Saturated Steam up to 10 Bar (150 PSI) Vacuum service to 29 in. Hg
---------------------------------	--

Ordering Information

<div style="border: 1px solid black; width: 30px; height: 30px; margin: 0 auto;"></div> <p>Style</p>	<div style="border: 1px solid black; width: 30px; height: 30px; margin: 0 auto;"></div> <p>Ports</p>	<div style="border: 1px solid black; width: 30px; height: 30px; margin: 0 auto; text-align: center; font-weight: bold; line-height: 30px;">P</div> <p>Material</p>	<div style="border: 1px solid black; width: 30px; height: 30px; margin: 0 auto;"></div> <p>Size</p>	<div style="border: 1px solid black; width: 30px; height: 30px; margin: 0 auto;"></div> <p>Options</p>	<div style="border: 1px dashed black; width: 30px; height: 30px; margin: 0 auto;"></div> <p>Design Series</p> <p>NOTE: Not required when ordering.</p>																																																								
<table border="1" style="width: 100%; border-collapse: collapse;"> <thead> <tr> <th style="text-align: left;">Code</th> <th style="text-align: left;">Description</th> </tr> </thead> <tbody> <tr><td>V</td><td>Valve</td></tr> <tr><td>VP *</td><td>Valve, Padlocking Handle</td></tr> <tr><td>VV **</td><td>Valve, Vented</td></tr> <tr><td>VVP **</td><td>Valve Vented, Padlocking Handle</td></tr> </tbody> </table> <p>* Only available up to #16 SAE in Series 506.</p> <p>** Not available in Series 506 and only available up to size 16 in other series.</p>	Code	Description	V	Valve	VP *	Valve, Padlocking Handle	VV **	Valve, Vented	VVP **	Valve Vented, Padlocking Handle	<table border="1" style="width: 100%; border-collapse: collapse;"> <thead> <tr> <th style="text-align: left;">Code</th> <th style="text-align: left;">Description</th> </tr> </thead> <tbody> <tr><td>500</td><td>Female/Female NPT Ports</td></tr> <tr><td>501</td><td>Male/Female NPT Ports</td></tr> <tr><td>502</td><td>Female/Female NPT Ports Panel Mount</td></tr> <tr><td>506</td><td>Female/Female Straight Thread O-ring Ports</td></tr> <tr><td>510</td><td>Male/Female Straight Thread O-ring Ports</td></tr> </tbody> </table>	Code	Description	500	Female/Female NPT Ports	501	Male/Female NPT Ports	502	Female/Female NPT Ports Panel Mount	506	Female/Female Straight Thread O-ring Ports	510	Male/Female Straight Thread O-ring Ports	<table border="1" style="width: 100%; border-collapse: collapse;"> <thead> <tr> <th style="text-align: left;">Code</th> <th style="text-align: left;">Description</th> </tr> </thead> <tbody> <tr><td>P</td><td>Brass</td></tr> </tbody> </table>	Code	Description	P	Brass	<table border="1" style="width: 100%; border-collapse: collapse;"> <thead> <tr> <th style="text-align: left;">Code</th> <th style="text-align: left;">Size</th> </tr> </thead> <tbody> <tr><td>4</td><td>1/4" NPT</td></tr> <tr><td>6</td><td>3/8" NPT</td></tr> <tr><td>8</td><td>1/2" NPT</td></tr> <tr><td>12</td><td>3/4" NPT</td></tr> <tr><td>16</td><td>1" NPT</td></tr> <tr><td>20*</td><td>1 1/4" NPT</td></tr> <tr><td>24*</td><td>1 1/2" NPT</td></tr> <tr><td>32*</td><td>2" NPT</td></tr> </tbody> </table> <p>* Available only in 500 Type</p>	Code	Size	4	1/4" NPT	6	3/8" NPT	8	1/2" NPT	12	3/4" NPT	16	1" NPT	20*	1 1/4" NPT	24*	1 1/2" NPT	32*	2" NPT	<table border="1" style="width: 100%; border-collapse: collapse;"> <thead> <tr> <th style="text-align: left;">Code</th> <th style="text-align: left;">Description</th> </tr> </thead> <tbody> <tr><td>Omit</td><td>No option</td></tr> <tr><td>01</td><td>Stainless Steel Ball & Stem (Size 4 to 16 only)</td></tr> <tr><td>02</td><td>Stainless Steel Handle & Nut</td></tr> <tr><td>03</td><td>Stainless Steel Ball, Stem, Handle & Nut (Size 4 to 16 only)</td></tr> <tr><td>04</td><td>T Handle</td></tr> </tbody> </table>	Code	Description	Omit	No option	01	Stainless Steel Ball & Stem (Size 4 to 16 only)	02	Stainless Steel Handle & Nut	03	Stainless Steel Ball, Stem, Handle & Nut (Size 4 to 16 only)	04	T Handle	
Code	Description																																																												
V	Valve																																																												
VP *	Valve, Padlocking Handle																																																												
VV **	Valve, Vented																																																												
VVP **	Valve Vented, Padlocking Handle																																																												
Code	Description																																																												
500	Female/Female NPT Ports																																																												
501	Male/Female NPT Ports																																																												
502	Female/Female NPT Ports Panel Mount																																																												
506	Female/Female Straight Thread O-ring Ports																																																												
510	Male/Female Straight Thread O-ring Ports																																																												
Code	Description																																																												
P	Brass																																																												
Code	Size																																																												
4	1/4" NPT																																																												
6	3/8" NPT																																																												
8	1/2" NPT																																																												
12	3/4" NPT																																																												
16	1" NPT																																																												
20*	1 1/4" NPT																																																												
24*	1 1/2" NPT																																																												
32*	2" NPT																																																												
Code	Description																																																												
Omit	No option																																																												
01	Stainless Steel Ball & Stem (Size 4 to 16 only)																																																												
02	Stainless Steel Handle & Nut																																																												
03	Stainless Steel Ball, Stem, Handle & Nut (Size 4 to 16 only)																																																												
04	T Handle																																																												

Performance Curves

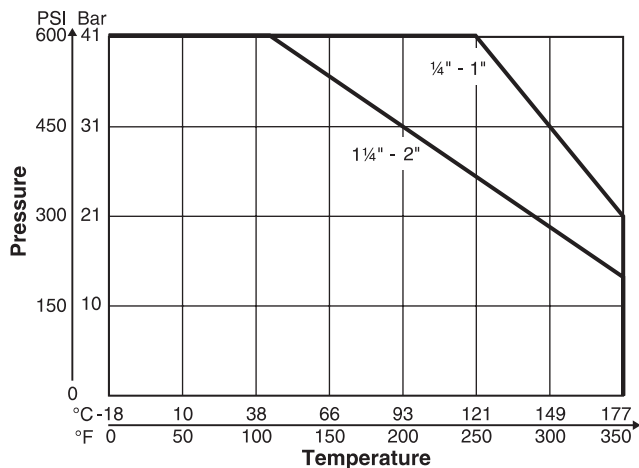

Flow Data

Type 500, 502		Type 510		Type 501		Type 506	
Valve Size	C _v	Valve Size	C _v	Valve Size	C _v	Valve Size	C _v
1/4"	4.0	#4	0.8	1/4"	6.3	#4	4.0
3/8"	5.8	#6	2.1	3/8"	5.7	#6	5.8
1/2"	12.0	#8	5.3	1/2"	10.0	#8	12.0
3/4"	25.0	#12	13.0	3/4"	25.0	#12	25.0
1"	35.0	#16	33.0	1"	35.0	#16	35.0
1-1/4"	57.0	-	-	-	-	#20	57.0
1-1/2"	92.0	-	-	-	-	#24	92.0
2"	224.0	-	-	-	-	#32	224.0

Model V500P and VP500P

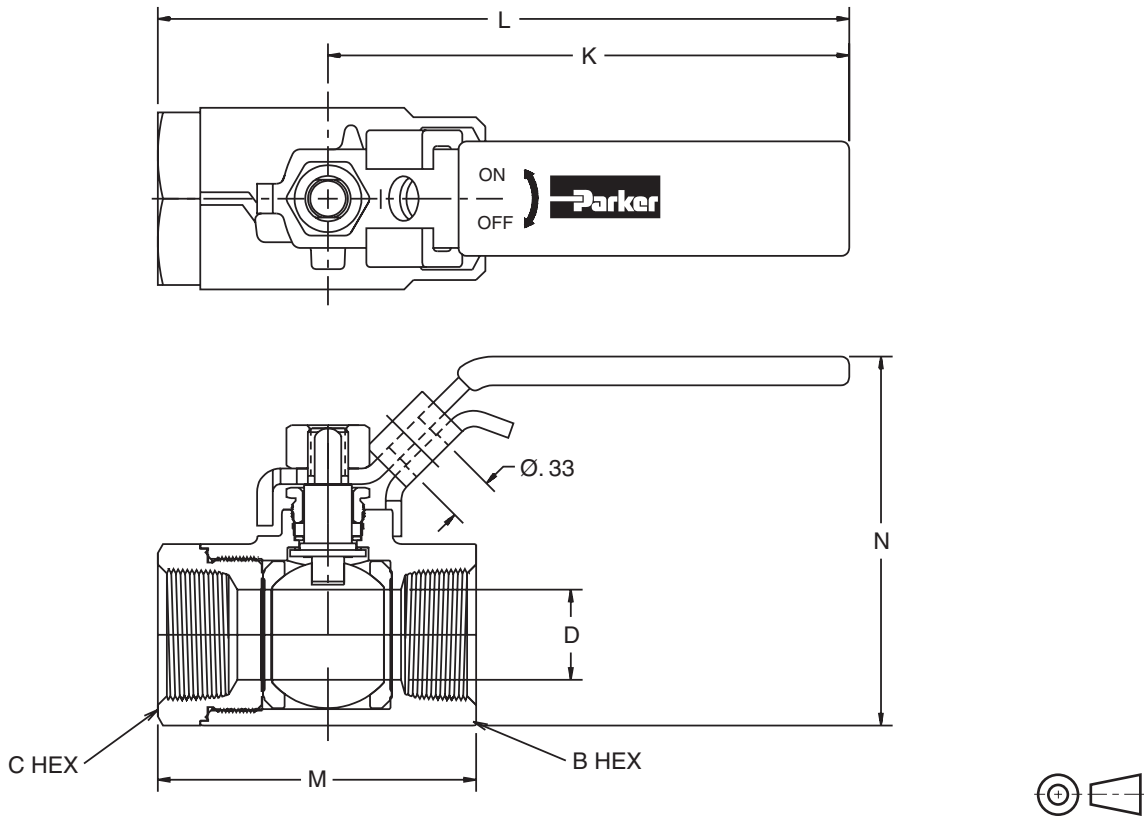

Part Number	Pipe Thread (PTF)	B Hex	C Hex	Dimensions mm (in)				D Flow Ø
				K	L	M	N	
Female-Female Pipe Ends V500P								
V500P4	1/4"	15/16"	15/16"	100.6 (3.96)	124.5 (4.90)	51.6 (2.03)	62.7 (2.47)	9.5 (0.375)
V500P6	3/8"	15/16"	15/16"	100.6 (3.96)	124.5 (4.90)	51.6 (2.03)	62.7 (2.47)	9.5 (0.375)
V500P8	1/2"	1-1/16"	1-1/16"	100.6 (3.96)	127.0 (5.00)	55.9 (2.20)	65.5 (2.58)	12.7 (0.500)
V500P12	3/4"	1-1/4"	1-5/16"	100.6 (3.96)	133.4 (5.25)	61.5 (2.42)	71.4 (2.81)	17.4 (0.685)
V500P16	1"	1-1/2"	1-9/16"	100.6 (3.96)	135.6 (5.34)	69.9 (2.75)	78.2 (3.08)	22.2 (0.875)
Locking Handle, Female Pipe Ends VP500P (Shown above)								
VP500P4	1/4"	15/16"	15/16"	100.6 (3.96)	124.5 (4.90)	51.6 (2.03)	62.7 (2.47)	9.5 (0.375)
VP500P6	3/8"	15/16"	15/16"	100.6 (3.96)	124.5 (4.90)	51.6 (2.03)	62.7 (2.47)	9.5 (0.375)
VP500P8	1/2"	1-1/16"	1-1/16"	100.6 (3.96)	127.0 (5.00)	55.9 (2.20)	65.5 (2.58)	12.7 (0.500)
VP500P12	3/4"	1-1/4"	1-5/16"	100.6 (3.96)	133.4 (5.25)	61.5 (2.42)	71.4 (2.81)	17.4 (0.685)
VP500P16	1"	1-1/2"	1-9/16"	100.6 (3.96)	135.6 (5.34)	69.9 (2.75)	78.2 (3.08)	22.2 (0.875)

Locking handle parts: For use with 5/16" Ø shank lock; 33Ø

Model VV500P and VVP500P

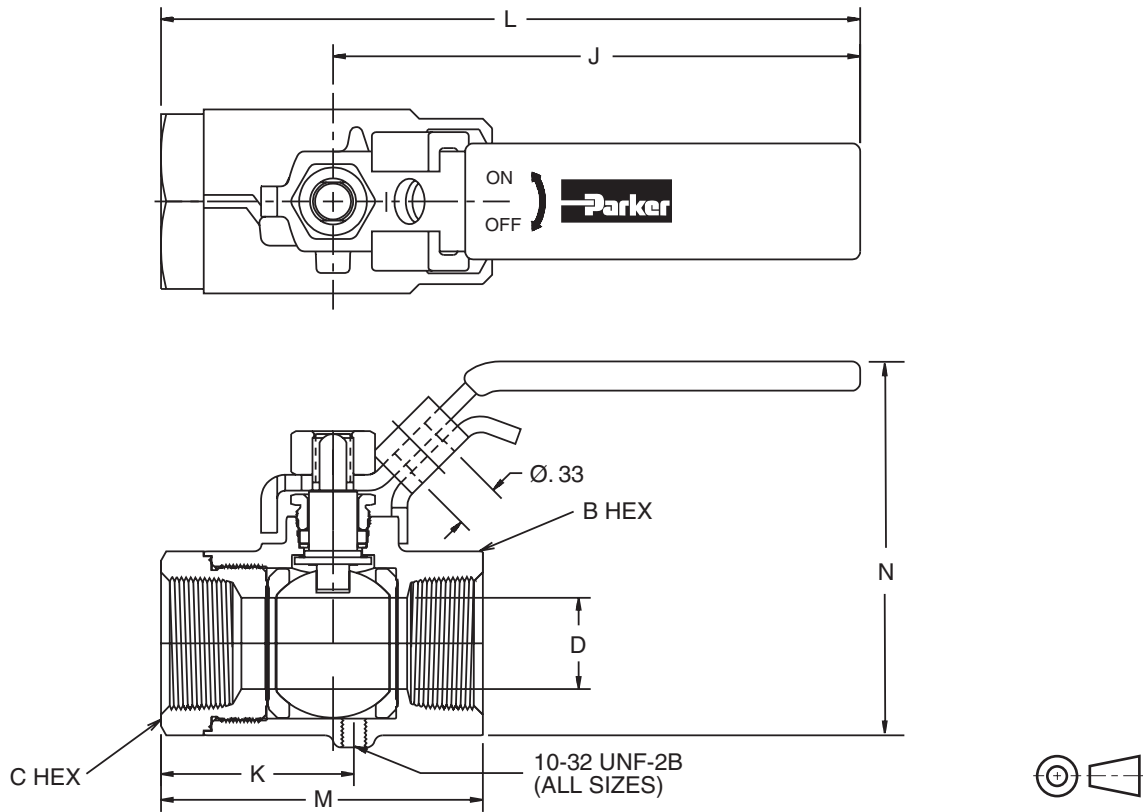

Part Number	Pipe Thread	B Hex	C Hex	Dimensions mm (in)					D Flow Ø
				J	K	L	M	N	
Vented, Female Pipe Ends VV500P									
VV500P4	1/4"	15/16"	15/16"	100.6 (3.96)	28.2 (1.11)	124.5 (4.90)	51.6 (2.03)	62.7 (2.47)	9.5 (0.375)
VV500P6	3/8"	15/16"	15/16"	100.6 (3.96)	28.2 (1.11)	124.5 (4.90)	51.6 (2.03)	62.7 (2.47)	9.5 (0.375)
VV500P8	1/2"	1-1/16"	1-1/16"	100.6 (3.96)	31.2 (1.23)	127.0 (5.00)	55.9 (2.20)	65.5 (2.58)	12.7 (0.500)
VV500P12	3/4"	1-1/4"	1-5/16"	100.6 (3.96)	36.8 (1.45)	133.4 (5.25)	61.5 (2.42)	71.4 (2.81)	17.4 (0.685)
VV500P16	1"	1-1/2"	1-9/16"	100.6 (3.96)	40.1 (1.58)	135.6 (5.34)	69.9 (2.75)	78.2 (3.08)	22.2 (0.875)
OSHA 29 CFR Part 1910 Vented, Locking Handle, Female Pipe Ends VVP500P (Shown above)									
VVP500P4	1/4"	15/16"	15/16"	100.6 (3.96)	28.2 (1.11)	124.5 (4.90)	51.6 (2.03)	62.7 (2.47)	9.5 (0.375)
VVP500P6	3/8"	15/16"	15/16"	100.6 (3.96)	28.2 (1.11)	124.5 (4.90)	51.6 (2.03)	62.7 (2.47)	9.5 (0.375)
VVP500P8	1/2"	1-1/16"	1-1/16"	100.6 (3.96)	31.2 (1.23)	127.0 (5.00)	55.9 (2.20)	65.5 (2.58)	12.7 (0.500)
VVP500P12	3/4"	1-1/4"	1-5/16"	100.6 (3.96)	36.8 (1.45)	133.4 (5.25)	61.5 (2.42)	71.4 (2.81)	17.4 (0.685)
VVP500P16	1"	1-1/2"	1-9/16"	100.6 (3.96)	40.1 (1.58)	135.6 (5.34)	69.9 (2.75)	78.2 (3.08)	22.2 (0.875)

Locking handle parts: For use with 5/16" Ø shank lock

3300-ballvalves.indd, ddp



Model V501P and VP501P

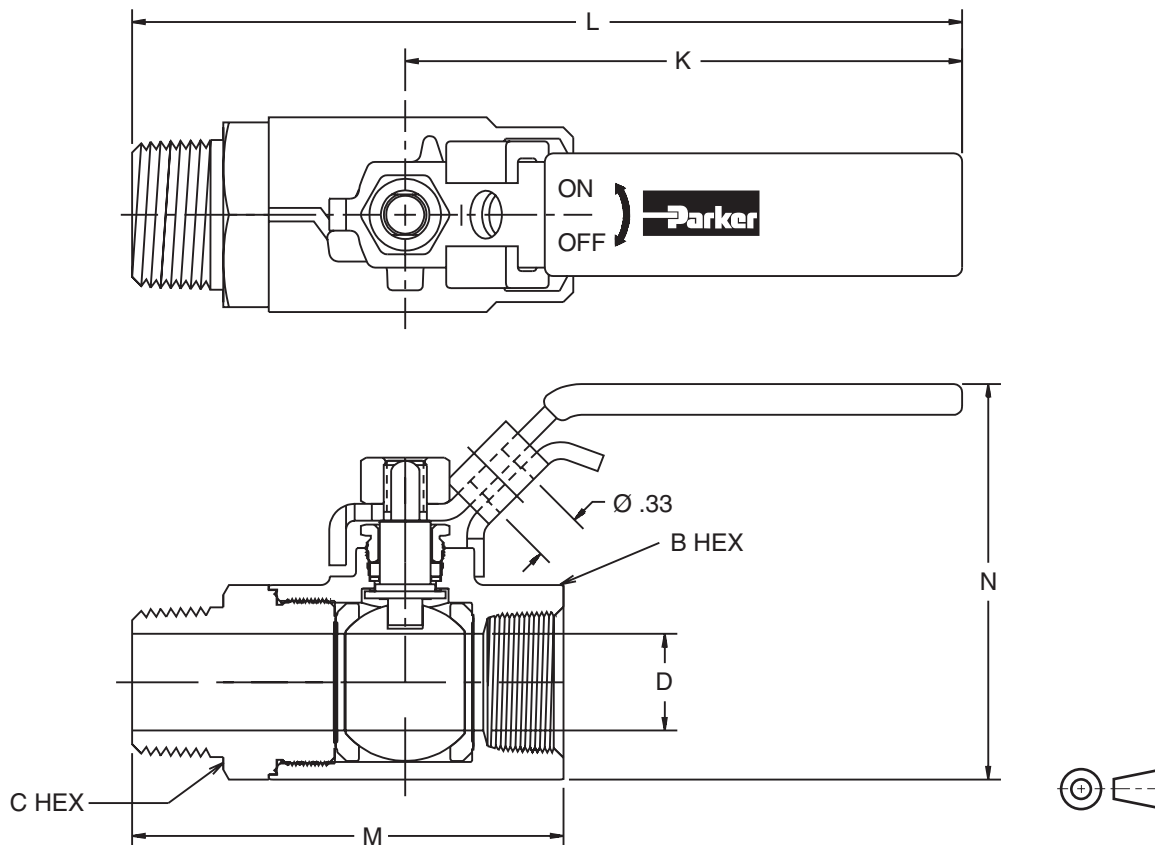

Part Number	Pipe Thread	B Hex	C Hex	Dimensions mm (in)				D Flow Ø
				K	L	M	N	
Male-Female Pipe Ends V501P								
V501P4	1/4"	15/16"	15/16"	100.6 (3.96)	138.7 (5.46)	65.8 (2.59)	62.7 (2.47)	8.7 (0.344)
V501P6	3/8"	15/16"	15/16"	100.6 (3.96)	138.7 (5.46)	65.8 (2.59)	62.7 (2.47)	9.5 (0.375)
V501P8	1/2"	1-1/16"	1-1/16"	100.6 (3.96)	146.1 (5.75)	74.9 (2.95)	65.5 (2.58)	12.7 (0.500)
V501P12	3/4"	1-1/4"	1-5/16"	100.6 (3.96)	148.1 (5.83)	76.2 (3.00)	71.4 (2.81)	17.4 (0.685)
V501P16	1"	1-1/2"	1-9/16"	100.6 (3.96)	157.2 (6.19)	91.4 (3.60)	78.2 (3.08)	22.2 (0.875)
Locking Handle, Male-Female Pipe Ends VP501P (Shown above)								
VP501P4	1/4"	15/16"	15/16"	100.6 (3.96)	138.7 (5.46)	65.8 (2.59)	62.7 (2.47)	8.7 (0.344)
VP501P6	3/8"	15/16"	15/16"	100.6 (3.96)	138.7 (5.46)	65.8 (2.59)	62.7 (2.47)	9.5 (0.375)
VP501P8	1/2"	1-1/16"	1-1/16"	100.6 (3.96)	146.1 (5.75)	74.9 (2.95)	65.5 (2.58)	12.7 (0.500)
VP501P12	3/4"	1-1/4"	1-5/16"	100.6 (3.96)	148.1 (5.83)	76.2 (3.00)	71.4 (2.81)	17.4 (0.685)
VP501P16	1"	1-1/2"	1-9/16"	100.6 (3.96)	157.2 (6.19)	91.4 (3.60)	78.2 (3.08)	22.2 (0.875)

Locking handle parts: For use with 5/16" Ø shank lock

Model VV501P and VVP501P

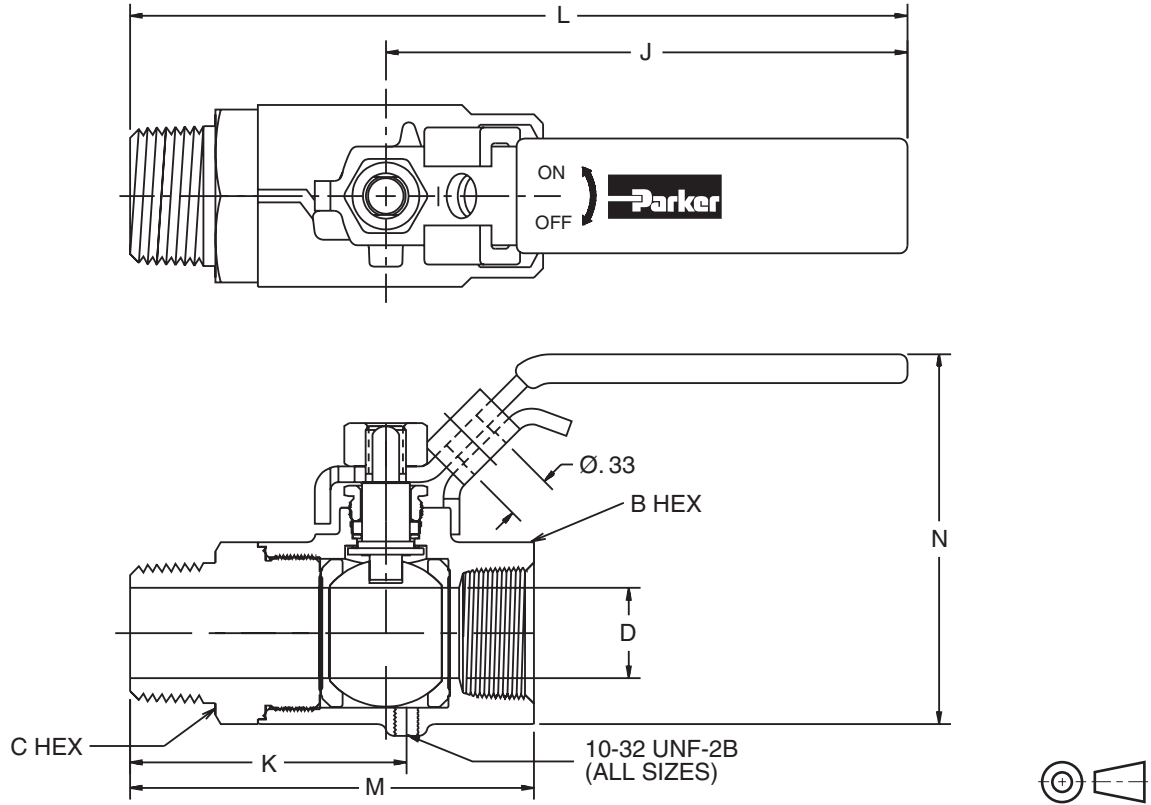

Part Number	Pipe Thread (PTF)	B Hex	C Hex	Dimensions mm (in)					D Flow Ø
				J	K	L	M	N	
Vented, Male-Female Pipe Ends VV501P									
VV501P4	1/4"	15/16"	15/16"	100.6 (3.96)	42.4 (1.67)	138.7 (5.46)	65.8 (2.59)	62.7 (2.47)	8.7 (0.344)
VV501P6	3/8"	15/16"	15/16"	100.6 (3.96)	42.4 (1.67)	138.7 (5.46)	65.8 (2.59)	62.7 (2.47)	9.5 (0.375)
VV501P8	1/2"	1-1/16"	1-1/16"	100.6 (3.96)	50.3 (1.98)	146.1 (5.75)	74.9 (2.95)	65.5 (2.58)	12.7 (0.500)
VV501P12	3/4"	1-1/4"	1-5/16"	100.6 (3.96)	51.6 (2.03)	148.1 (5.83)	76.2 (3.00)	71.4 (2.81)	17.4 (0.685)
VV501P16	1"	1-1/2"	1-9/16"	100.6 (3.96)	61.7 (2.43)	157.2 (6.19)	91.4 (3.60)	78.2 (3.08)	22.2 (0.875)
OSHA 29 CFR Part 1910 Vented, Locking Handle, Male-Female Pipe Ends VVP501P (Shown above)									
VVP501P4	1/4"	15/16"	15/16"	100.6 (3.96)	42.4 (1.67)	138.7 (5.46)	65.8 (2.59)	62.7 (2.47)	8.7 (0.344)
VVP501P6	3/8"	15/16"	15/16"	100.6 (3.96)	42.4 (1.67)	138.7 (5.46)	65.8 (2.59)	62.7 (2.47)	9.5 (0.375)
VVP501P8	1/2"	1-1/16"	1-1/16"	100.6 (3.96)	50.3 (1.98)	146.1 (5.75)	74.9 (2.95)	65.5 (2.58)	12.7 (0.500)
VVP501P12	3/4"	1-1/4"	1-5/16"	100.6 (3.96)	51.6 (2.03)	148.1 (5.83)	76.2 (3.00)	71.4 (2.81)	17.4 (0.685)
VVP501P16	1"	1-1/2"	1-9/16"	100.6 (3.96)	61.7 (2.43)	157.2 (6.19)	91.4 (3.60)	78.2 (3.08)	22.2 (0.875)

Locking handle parts: For use with 5/16" Ø shank lock

Model V502P and VP502P

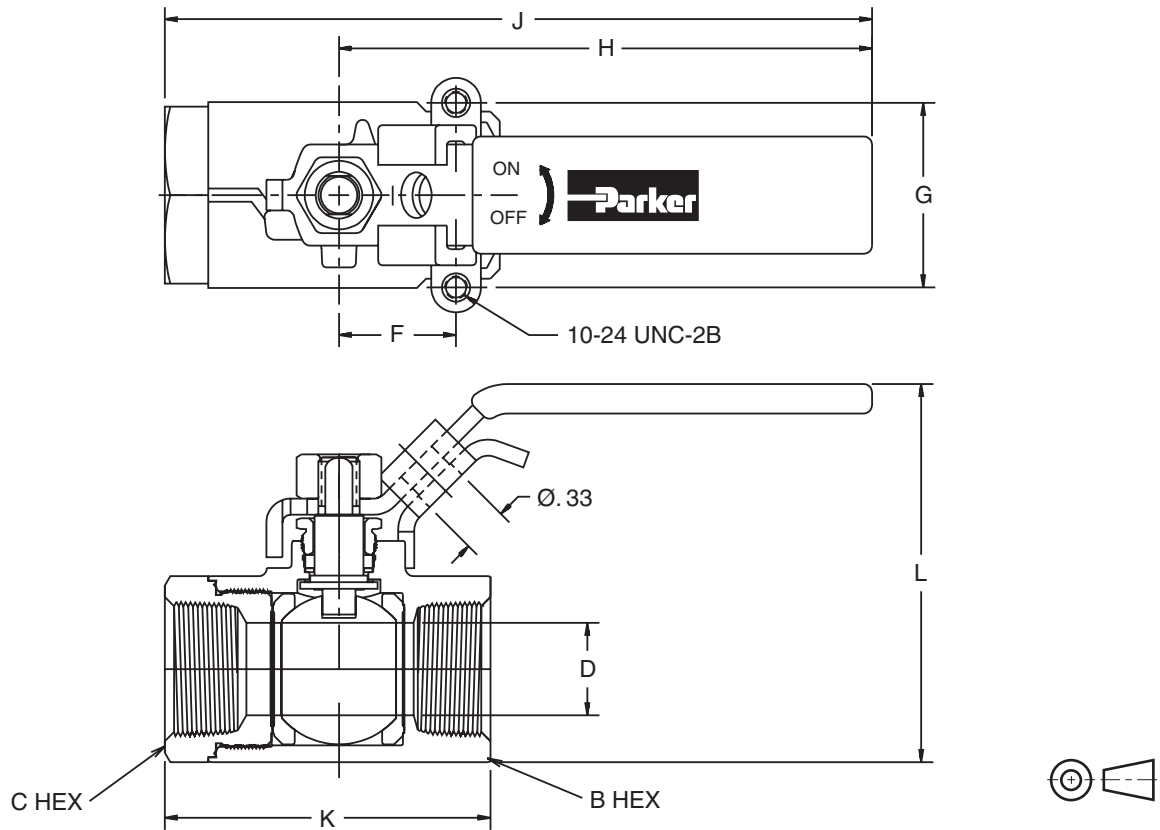

Part Number	Pipe Thread	B Hex	C Hex	Dimensions mm (in)						D Flow Ø
				F	G	H	J	K	L	
Female-Female Pipe Ends, Panel Mount V502P										
V502P4	1/4"	15/16"	15/16"	12.7 (0.50)	28.4 (1.12)	100.6 (3.96)	124.5 (4.90)	51.6 (2.03)	62.7 (2.47)	9.5 (0.375)
V502P6	3/8"	15/16"	15/16"	12.7 (0.50)	28.4 (1.12)	100.6 (3.96)	124.5 (4.90)	51.6 (2.03)	62.7 (2.47)	9.5 (0.375)
V502P8	1/2"	1-1/16"	1-1/16"	12.7 (0.50)	28.4 (1.12)	100.6 (3.96)	127.0 (5.00)	55.9 (2.20)	65.5 (2.58)	12.7 (0.500)
V502P12	3/4"	1-1/4"	1-5/16"	22.1 (0.87)	34.8 (1.37)	100.6 (3.96)	133.4 (5.25)	61.5 (2.42)	71.4 (2.81)	17.4 (0.685)
V502P16	1"	1-1/2"	1-9/16"	22.1 (0.87)	34.8 (1.37)	100.6 (3.96)	135.6 (5.34)	69.9 (2.75)	78.2 (3.08)	22.2 (0.875)
Locking Handle, Female Pipe Ends, Panel Mount VP502P (Shown above)										
VP502P4	1/4"	15/16"	15/16"	12.7 (0.50)	28.4 (1.12)	100.6 (3.96)	124.5 (4.90)	51.6 (2.03)	62.7 (2.47)	9.5 (0.375)
VP502P6	3/8"	15/16"	15/16"	12.7 (0.50)	28.4 (1.12)	100.6 (3.96)	124.5 (4.90)	51.6 (2.03)	62.7 (2.47)	9.5 (0.375)
VP502P8	1/2"	1-1/16"	1-1/16"	12.7 (0.50)	28.4 (1.12)	100.6 (3.96)	127.0 (5.00)	55.9 (2.20)	65.5 (2.58)	12.7 (0.500)
VP502P12	3/4"	1-1/4"	1-5/16"	22.1 (0.87)	34.8 (1.37)	100.6 (3.96)	133.4 (5.25)	61.5 (2.42)	71.4 (2.81)	17.4 (0.685)
VP502P16	1"	1-1/2"	1-9/16"	22.1 (0.87)	34.8 (1.37)	100.6 (3.96)	135.6 (5.34)	69.9 (2.75)	78.2 (3.08)	22.2 (0.875)

Locking handle parts: For use with 5/16" Ø shank lock

Model VV502P and VVP502P

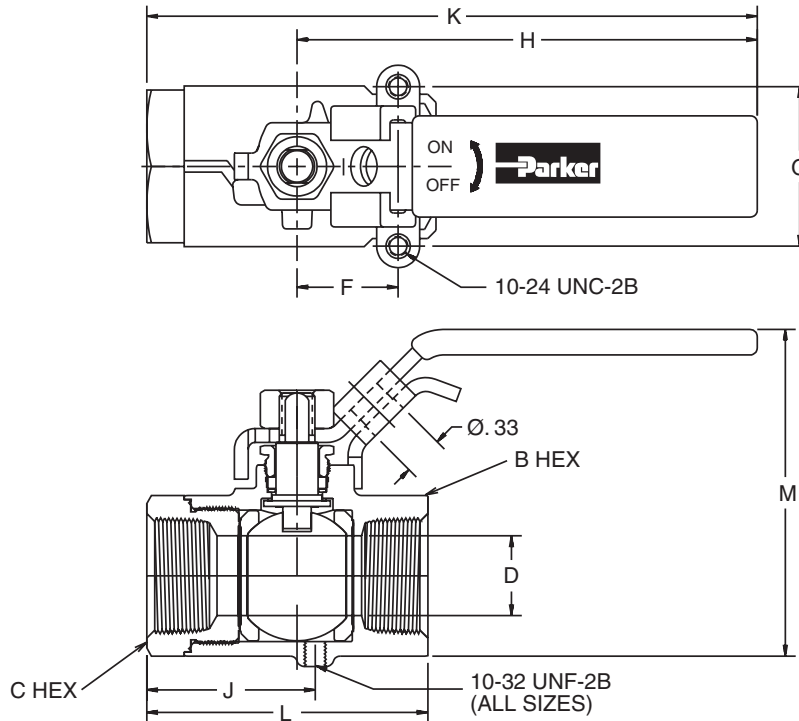

Part Number	Pipe Thread	B Hex	C Hex	Dimensions mm (in)							D Flow Ø
				F	G	H	J	K	L	M	
Vented, Female-Female Pipe Ends, Panel Mount VV502P											
VV502P4	1/4"	15/16"	15/16"	12.7 (0.50)	28.4 (1.12)	100.6 (3.96)	28.2 (1.11)	124.5 (4.90)	51.6 (2.03)	62.7 (2.47)	9.5 (0.375)
VV502P6	3/8"	15/16"	15/16"	12.7 (0.50)	28.4 (1.12)	100.6 (3.96)	28.2 (1.11)	124.5 (4.90)	51.6 (2.03)	62.7 (2.47)	9.5 (0.375)
VV502P8	1/2"	1-1/16"	1-1/16"	12.7 (0.50)	28.4 (1.12)	100.6 (3.96)	31.2 (1.23)	127.0 (5.00)	55.9 (2.20)	65.5 (2.58)	12.7 (0.500)
VV502P12	3/4"	1-1/4"	1-5/16"	22.1 (0.87)	34.8 (1.37)	100.6 (3.96)	36.8 (1.45)	133.4 (5.25)	61.5 (2.42)	71.4 (2.81)	17.4 (0.685)
VV502P16	1"	1-1/2"	1-9/16"	22.1 (0.87)	34.8 (1.37)	100.6 (3.96)	40.1 (1.58)	135.6 (5.34)	69.9 (2.75)	78.2 (3.08)	22.2 (0.875)
OSHA 29 CFR Part 1910 Vented, Locking Handle, Female Pipe Ends, Panel Mount VVP502P (Shown above)											
VVP502P4	1/4"	15/16"	15/16"	12.7 (0.50)	28.4 (1.12)	100.6 (3.96)	28.2 (1.11)	124.5 (4.90)	51.6 (2.03)	62.7 (2.47)	9.5 (0.375)
VVP502P6	3/8"	15/16"	15/16"	12.7 (0.50)	28.4 (1.12)	100.6 (3.96)	28.2 (1.11)	124.5 (4.90)	51.6 (2.03)	62.7 (2.47)	9.5 (0.375)
VVP502P8	1/2"	1-1/16"	1-1/16"	12.7 (0.50)	28.4 (1.12)	100.6 (3.96)	31.2 (1.23)	127.0 (5.00)	55.9 (2.20)	65.5 (2.58)	12.7 (0.500)
VVP502P12	3/4"	1-1/4"	1-5/16"	22.1 (0.87)	34.8 (1.37)	100.6 (3.96)	36.8 (1.45)	133.4 (5.25)	61.5 (2.42)	71.4 (2.81)	17.4 (0.685)
VVP502P16	1"	1-1/2"	1-9/16"	22.1 (0.87)	34.8 (1.37)	100.6 (3.96)	40.1 (1.58)	135.6 (5.34)	69.9 (2.75)	78.2 (3.08)	22.2 (0.875)

Locking handle parts: For use with 5/16" Ø shank lock

Model V506P

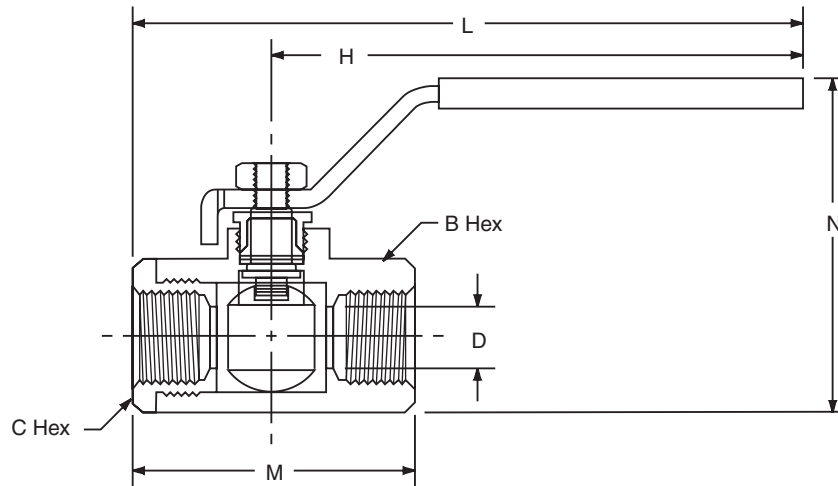

Part Number	Straight Thread	B Hex	C Hex	Dimensions mm (in)				D Flow Ø
				H	L	M	N	
Female/Female, Straight Thread O-Ring Port V506P								
V506P4	7/16-20	15/16"	15/16"	100.6 (3.96)	127.3 (5.01)	55.9 (2.20)	62.7 (2.47)	9.5 (0.375)
V506P6	9/16-18	15/16"	15/16"	100.6 (3.96)	128.8 (5.07)	57.4 (2.26)	62.7 (2.47)	9.5 (0.375)
V506P8	3/4-16	1-1/16"	1-1/16"	100.6 (3.96)	131.6 (5.18)	61.5 (2.42)	66.0 (2.60)	12.7 (0.500)
V506P12	1 1/16-12	1-1/4"	1-5/16"	100.6 (3.96)	149.1 (5.87)	87.9 (3.46)	71.4 (2.81)	17.4 (0.685)
V506P16	1 5/16-12	1-1/2"	1-9/16"	100.6 (3.96)	151.4 (5.96)	93.5 (3.68)	78.2 (3.08)	22.2 (0.875)

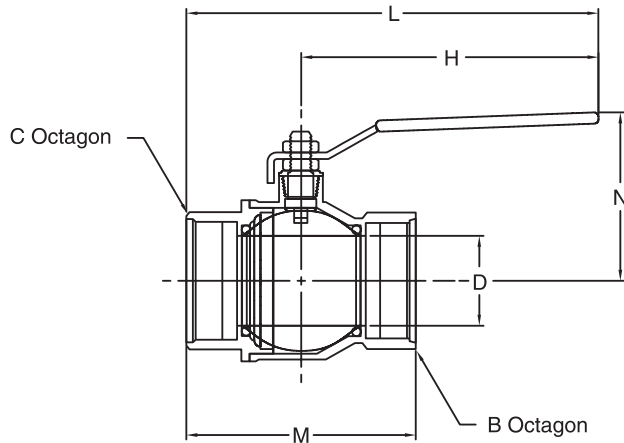

Part Number	Straight Thread	B Octagon	C Octagon	Dimensions mm (in)				D Flow Ø
				H	L	M	N	
Female/Female, Straight Thread O-Ring Port V506P								
V506P20	1 5/8-12	49.0 (1.93)	49.0 (1.93)	158.0 (6.22)	204.5 (8.05)	93.0 (3.66)	76.5 (3.01)	30.0 (1.18)
V506P24	1 7/8-12	54.1 (2.13)	54.1 (2.13)	158.0 (6.22)	209.0 (8.23)	102.1 (4.02)	82.6 (3.25)	38.1 (1.50)
V506P32	2 1/2-12	72.4 (2.85)	72.4 (2.85)	158.0 (6.22)	218.4 (8.60)	120.9 (4.76)	89.4 (3.52)	48.0 (1.89)

Model V510P and VP510P

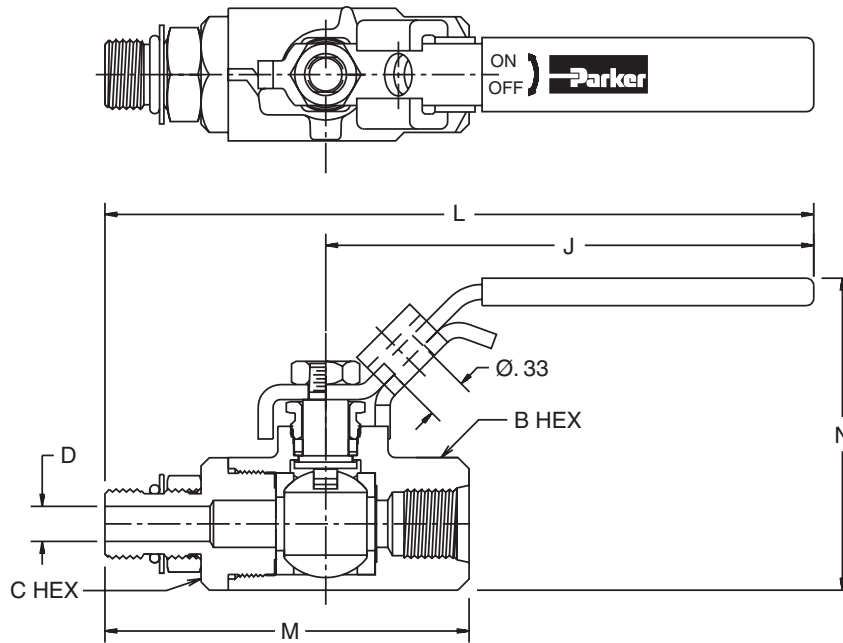

Part Number	Straight Thread	B Hex	C Hex	Dimensions mm (in)				D Flow Ø
				K	L	M	N	
Male-Female, Straight Thread O-Ring Port V510P								
V510P4	7/16-20	15/16"	15/16"	100.6 (3.96)	142.5 (5.61)	72.4 (2.85)	62.7 (2.47)	4.8 (0.188)
V510P6	9/16-18	15/16"	15/16"	100.6 (3.96)	144.3 (5.68)	74.2 (2.92)	62.7 (2.47)	7.1 (0.281)
V510P8	3/4-16	1-1/16"	1-1/16"	100.6 (3.96)	149.4 (5.88)	80.5 (3.17)	65.5 (2.58)	10.7 (0.422)
V510P12	1-1/16-12	1-1/4"	1-5/16"	100.6 (3.96)	163.6 (6.44)	102.4 (4.03)	71.4 (2.81)	16.7 (0.656)
V510P16	1-5/16-12	1-1/2"	1-9/16"	100.6 (3.96)	166.6 (6.56)	108.7 (4.28)	78.2 (3.08)	22.2 (0.875)
Locking Handle, Straight Thread O-Ring Port VP510P (Shown above)								
VP510P4	7/16-20	15/16"	15/16"	100.6 (3.96)	142.5 (5.61)	72.4 (2.85)	62.7 (2.47)	4.8 (0.188)
VP510P6	9/16-18	15/16"	15/16"	100.6 (3.96)	144.3 (5.68)	74.2 (2.92)	62.7 (2.47)	7.1 (0.281)
VP510P8	3/4-16	1-1/16"	1-1/16"	100.6 (3.96)	149.4 (5.88)	80.5 (3.17)	65.5 (2.58)	10.7 (0.422)

Model VV510P and VVP510P

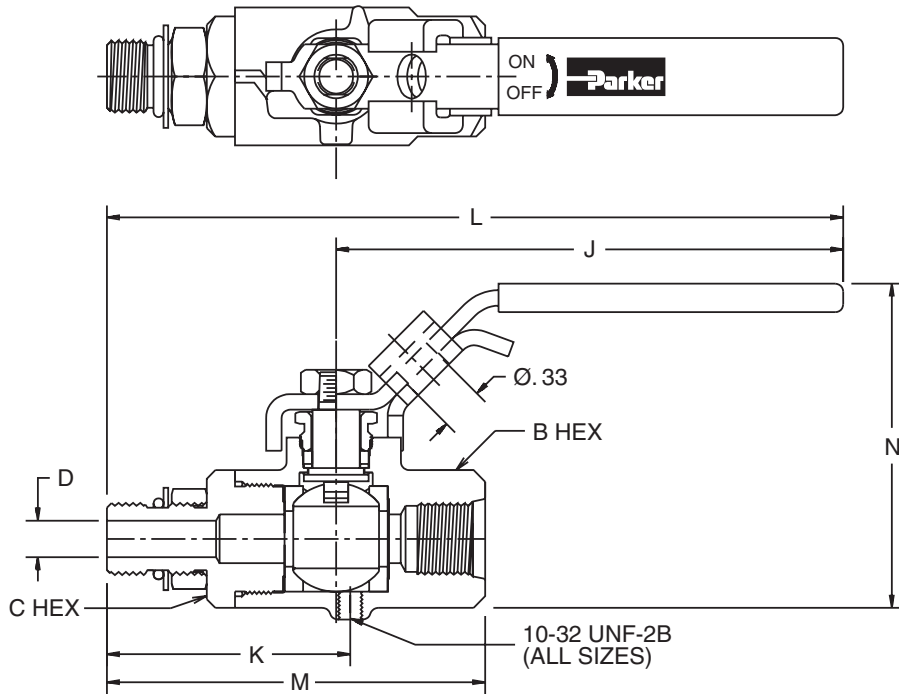

Part Number	Straight Thread	B Hex	C Hex	Dimensions mm (in)					D Flow Ø
				J	K	L	M	N	
Vented, Straight Thread O-Ring Port VV510P									
VV510P4	7/16-20	15/16"	15/16"	100.6 (3.96)	46.2 (1.82)	142.5 (5.61)	72.4 (2.85)	62.7 (2.47)	4.8 (0.188)
VV510P6	9/16-18	15/16"	15/16"	100.6 (3.96)	48.0 (1.89)	144.3 (5.68)	74.2 (2.92)	62.7 (2.47)	7.1 (0.281)
VV510P8	3/4-16	1-1/16"	1-1/16"	100.6 (3.96)	53.8 (2.12)	149.4 (5.88)	80.5 (3.17)	65.5 (2.58)	10.7 (0.422)
VV510P12	1-1/16-12	1-1/4"	1-5/16"	100.6 (3.96)	67.1 (2.64)	163.6 (6.44)	102.4 (4.03)	71.4 (2.81)	16.7 (0.656)
OSHA 29 CFR Part 1910 Vented, Locking Handle, Male-Female, Straight Thread O-Ring Port VV510P (Shown above)									
VVP510P4	7/16-20	15/16"	15/16"	100.6 (3.96)	46.2 (1.82)	142.5 (5.61)	72.4 (2.85)	62.7 (2.47)	4.8 (0.188)
VVP510P6	9/16-18	15/16"	15/16"	100.6 (3.96)	48.0 (1.89)	144.3 (5.68)	74.2 (2.92)	62.7 (2.47)	7.1 (0.281)
VVP510P8	3/4-16	1-1/16"	1-1/16"	100.6 (3.96)	53.8 (2.12)	149.4 (5.88)	80.5 (3.17)	65.5 (2.58)	10.7 (0.422)

General Description

Series 520 low pressure ball valves provide total shut-off capability for services up to 41 Bar (600 PSI). This economical ball valve is available in female pipe sizes.

Operation

A quarter turn of the handle is on or off. Ball valves are not intended for use as a throttling valve. Attempting to use it in these applications may result in premature seal failure and/or inability to turn the valve handle.

Features

- Ball valve bodies are machined forgings which provide extended service life and resist failure caused by severe temperature conditions.
- Full flow design assures maximum system efficiency.
- Highly inert PTFE seats provide resistance to chemical corrosion.
- Two fluorocarbon o-rings at the stem provide maximum safety with no maintenance.
- Blowout proof stem design, chrome plated brass ball and a special design handle enable increased turn and leverage for ease of opening and closing.

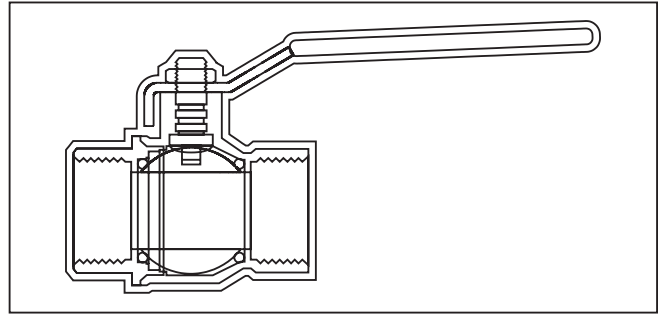
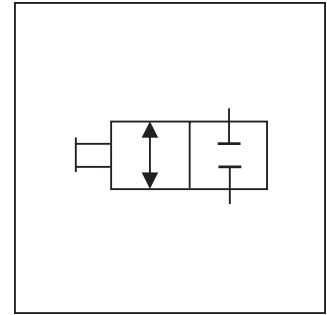
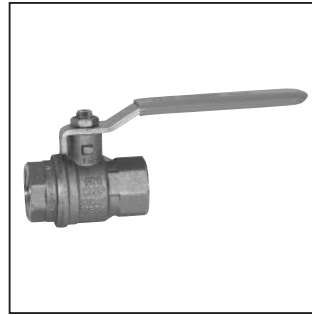

Specifications

Maximum Working Pressure	Sizes 1/4" - 2"	41 Bar (600 PSI)
	Sizes 2 1/2" - 3"	31 Bar (450 PSI)
	Saturated Steam up to 10 Bar (150 PSI) and 177°C (350°F)	
	Vacuum service to 29 in. Hg	

Ordering Information

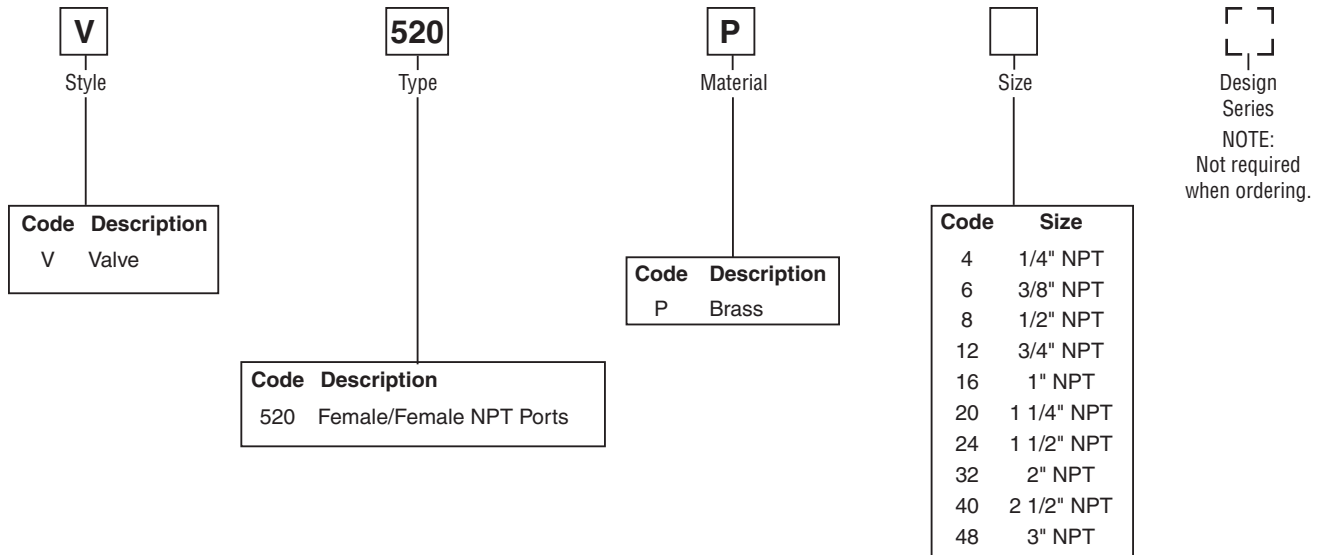

Performance Curves

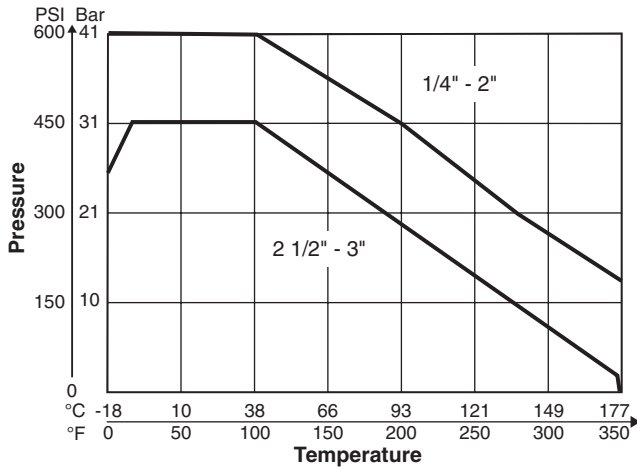

Dimensions

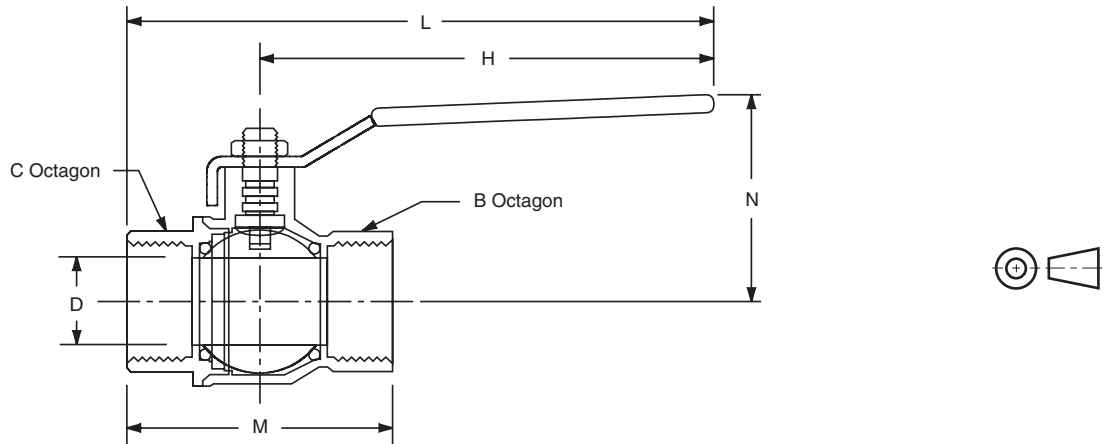

Part Number	Pipe Thread	B Octagon	C Octagon	Dimensions mm (in)				D Flow Ø
				H	L	M	N	
Brass Ball Valve V520P								
V520P4	1/4-18	20.1 (0.79)	20.1 (0.79)	100.1 (3.94)	122.7 (4.83)	45.0 (1.77)	38.1 (1.50)	7.9 (0.310)
V520P6	3/8-18	20.1 (0.79)	20.1 (0.79)	100.1 (3.94)	122.7 (4.83)	45.0 (1.77)	38.1 (1.50)	10.2 (0.400)
V520P8	1/2-14	24.9 (0.98)	24.9 (0.98)	100.1 (3.94)	129.5 (5.10)	58.9 (2.32)	42.9 (1.69)	15.2 (0.600)
V520P12	3/4-14	31.0 (1.22)	31.0 (1.22)	119.9 (4.72)	151.9 (5.98)	64.0 (2.52)	50.0 (1.97)	20.1 (0.790)
V520P16	1 -11.5	39.9 (1.57)	39.9 (1.57)	119.9 (4.72)	160.5 (6.32)	81.0 (3.19)	54.1 (2.13)	25.4 (1.000)
V520P20	1 1/4	49.0 (1.93)	49.0 (1.93)	158.0 (6.22)	204.5 (8.05)	93.0 (3.66)	71.6 (2.82)	31.8 (1.250)
V520P24	1 1/2	54.1 (2.13)	54.1 (2.13)	158.0 (6.22)	209.0 (8.23)	102.1 (4.02)	77.7 (3.06)	39.9 (1.570)
V520P32	2	68.3 (2.69)	68.3 (2.69)	158.0 (6.22)	217.9 (8.58)	120.9 (4.76)	84.6 (3.33)	50.8 (2.000)
V520P40	2 1/2	85.1 (3.35)	85.1 (3.35)	255.0 (10.04)	333.0 (13.11)	156.0 (6.14)	132.1 (5.20)	64.0 (2.520)
V520P48	3	98.8 (3.89)	98.8 (3.89)	255.0 (10.04)	343.4 (13.52)	177.0 (6.97)	140.0 (5.51)	76.2 (3.000)

3300-ballvalves.indd, ddp

General Description

Series 500CS low pressure carbon steel ball valves provide total shut-off capability for services up to 138 Bar (2000 PSI).

Operation

A quarter turn of the handle is on or off. Ball valves are not intended for use as a throttling valve. Attempting to use it in these applications may result in premature seal failure and/or inability to turn the valve handle.

Features

- Ball valve bodies are machined from high quality carbon steel and phosphate coated forgings providing superior corrosion resistance.
- Highly inert PTFE seats and seals provide resistance to chemical corrosion.
- Blowout proof stem design, chrome plated brass ball and a special design handle enable increased turn and leverage for ease of opening and closing.
- Padlocking handle options provides lock-out capability where required.
- In-line or panel mount options provide installation flexibility.

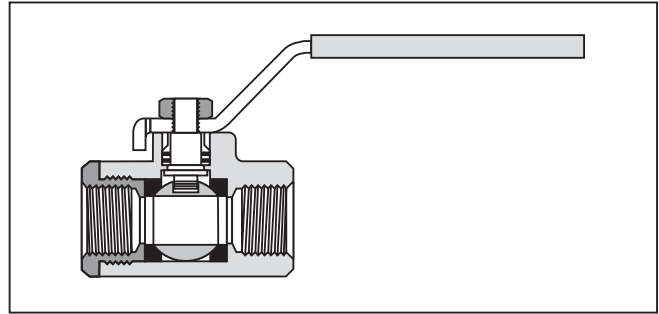
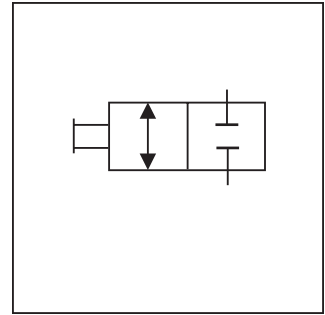

Specifications

Maximum Working Pressure	Sizes 1/4" - 1" 138 Bar (2000 PSI)
	Sizes 1 1/4" - 2" 103 Bar (1500 PSI)
	Saturated Steam up to 10 Bar (150 PSI) and 177C (350°F)
Body Material	Carbon Steel, Phosphate Coated

Performance Curves

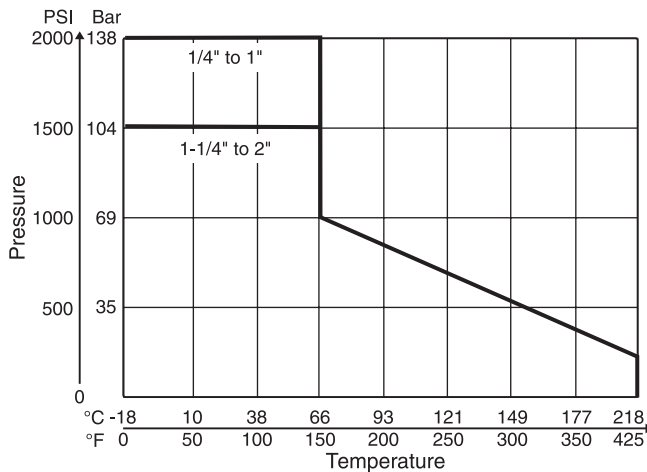

Flow Data

Type 500CS, 502CS	
Valve Size	C _v
1/4"	6.0
3/8"	12.0
1/2"	15.0
3/4"	23.0
1"	36.0
1-1/4"	44.0
1-1/2"	64.0
2"	114.0

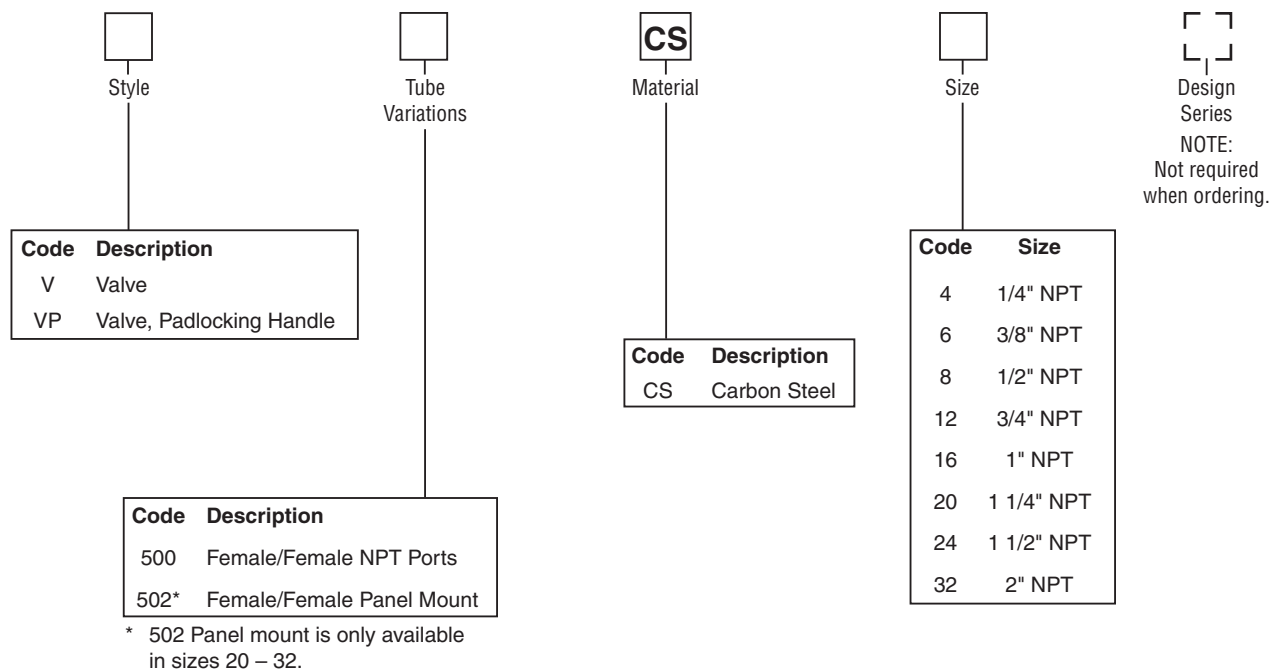

Model V500CS and VP500CS

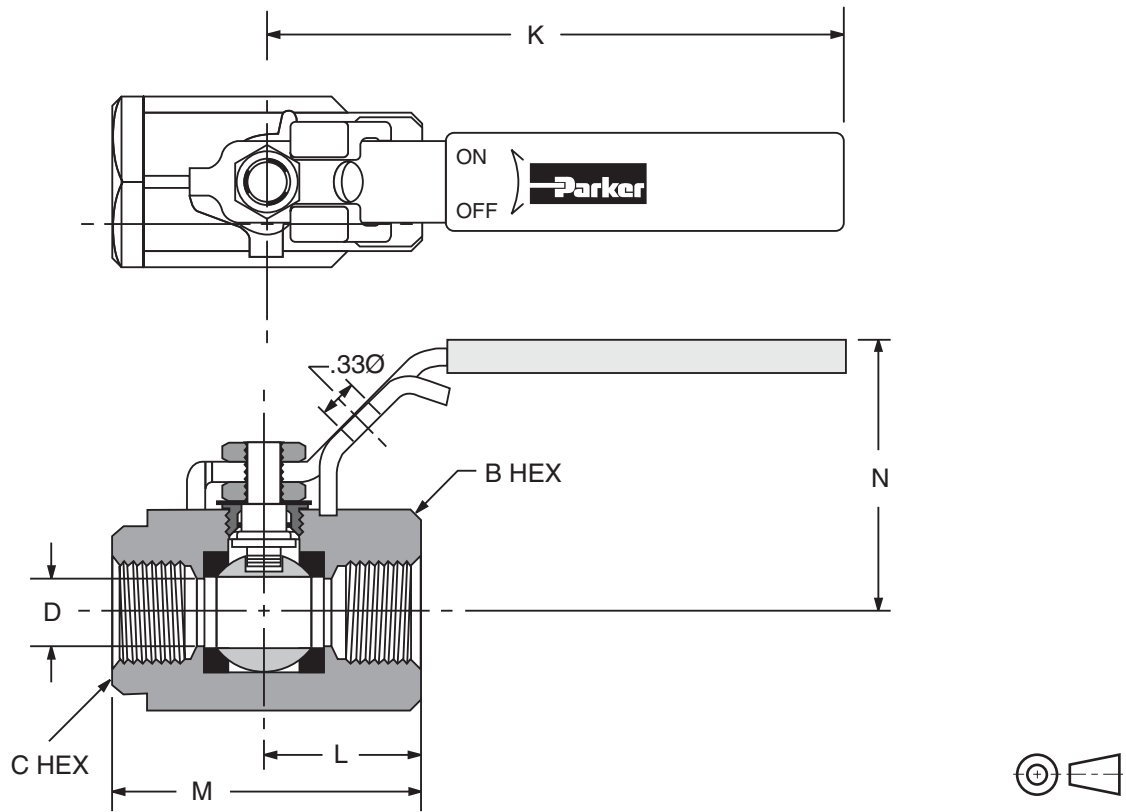

Part Number	Pipe Thread	B Hex	C Hex	Dimensions mm (in)				D Flow Ø
				K	L	M	N	
Female-Female Pipe Ends V500CS								
V500CS4	1/4"	1-1/16"	15/16"	96.0 (3.78)	25.4 (1.00)	50.8 (2.00)	41.4 (1.63)	10.2 (0.400)
V500CS6	3/8"	1-1/16"	15/16"	96.0 (3.78)	25.4 (1.00)	50.8 (2.00)	41.4 (1.63)	10.2 (0.400)
V500CS8	1/2"	1-1/4"	1-1/16"	96.0 (3.78)	31.8 (1.25)	60.2 (2.37)	43.9 (1.73)	13.7 (0.540)
V500CS12	3/4"	1-5/8"	1-3/8"	129.5 (5.10)	38.1 (1.50)	73.7 (2.90)	52.8 (2.08)	17.3 (0.680)
V500CS16	1"	2"	1-5/8"	129.5 (5.10)	44.7 (1.76)	86.6 (3.41)	58.4 (2.30)	22.4 (0.880)
Locking Handle, Female Pipe Ends VP500CS (Shown above)								
VP500CS4	1/4"	1-1/16"	15/16"	104.9 (4.13)	25.4 (1.00)	50.8 (2.00)	56.6 (2.23)	10.2 (0.400)
VP500CS6	3/8"	1-1/16"	15/16"	104.9 (4.13)	25.4 (1.00)	50.8 (2.00)	56.6 (2.23)	10.2 (0.400)
VP500CS8	1/2"	1-1/4"	1-1/16"	104.9 (4.13)	31.8 (1.25)	60.2 (2.37)	56.6 (2.23)	13.7 (0.540)
VP500CS12	3/4"	1-5/8"	1-3/8"	127.0 (5.00)	38.1 (1.50)	73.7 (2.90)	71.1 (2.80)	17.3 (0.680)
VP500CS16	1"	2"	1-5/8"	127.0 (5.00)	44.7 (1.76)	86.6 (3.41)	75.4 (2.97)	22.4 (0.880)

Model V502CS and VP502CS

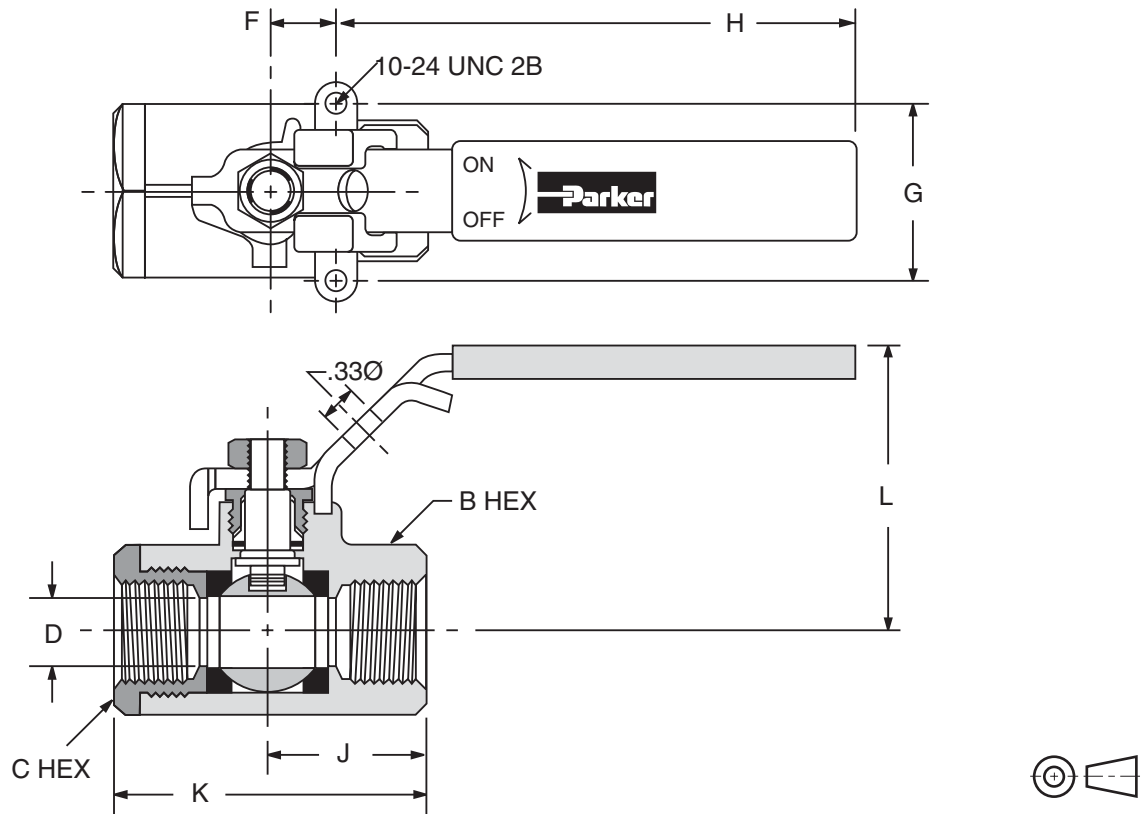

Part Number	Pipe Thread	B Hex	C Hex	Dimensions mm (in)						D Flow Ø
				F	G	H	J	K	L	
Female-Female Pipe Ends, Panel Mount V502CS										
V502CS20	1-1/4"	2"	2-1/4"	23.9 (0.94)	38.1 (1.50)	154.9 (6.10)	47.5 (1.87)	96.5 (3.80)	70.1 (2.76)	25.4 (1.000)
V502CS24	1-1/2"	2-5/16"	2-1/2"	23.9 (0.94)	38.1 (1.50)	154.9 (6.10)	57.7 (2.27)	115.6 (4.55)	75.7 (2.98)	31.8 (1.250)
V502CS32	2"	2-3/4"	3"	26.2 (1.03)	50.8 (2.00)	218.4 (8.60)	61.5 (2.42)	122.7 (4.83)	89.9 (3.54)	38.1 (1.500)
Locking Handle, Female Pipe Ends, Panel Mount VP502CS (Shown above)										
VP502CS20	1-1/4"	2"	2-1/4"	23.9 (0.94)	38.1 (1.50)	190.5 (7.50)	47.5 (1.87)	96.5 (3.80)	80.0 (3.15)	25.4 (1.000)
VP502CS24	1-1/2"	2-5/16"	2-1/2"	23.9 (0.94)	38.1 (1.50)	190.5 (7.50)	57.7 (2.27)	115.6 (4.55)	85.6 (3.37)	31.8 (1.250)
VP502CS32	2"	2-3/4"	3"	26.2 (1.03)	50.8 (2.00)	222.3 (8.75)	61.5 (2.42)	122.7 (4.83)	87.9 (3.46)	38.1 (1.500)

General Description

Series 50*SS low pressure, stainless steel ball valves provide total shut-off capability for services up to 138 Bar (2000 PSI).

Operation

A quarter turn of the handle is on or off. Ball Valves are not intended for use as a throttling valve. Attempting to use it in these applications may result in premature seal failure and/or inability to turn the valve handle.

Features

- Ball valve bodies are machined from CF-8M stainless steel castings, equivalent of 316 stainless steel which is suited for corrosive environments.
- Highly inert PTFE seats and seals provide resistance to chemical corrosion.
- Blowout proof stem design, 316 stainless ball and a special design handle enable increased turn and leverage for ease of opening and closing.
- Padlocking handle option provides lock-out capability where required.
- Style 502 allows panel mounting for installation flexibility.

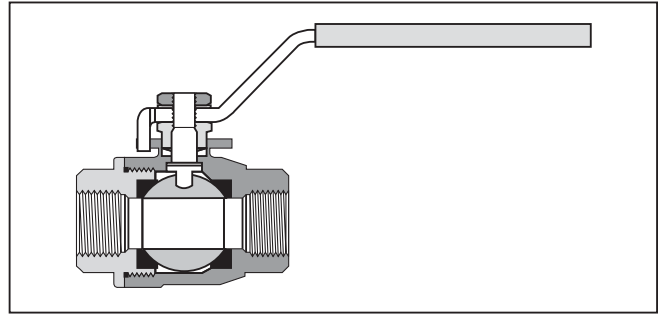
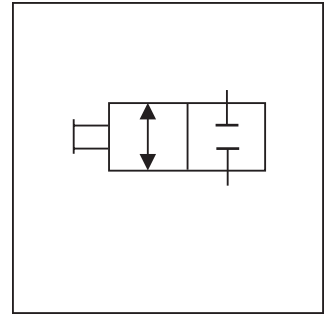

Specifications

Maximum Working Pressure	Sizes 1/4" - 1" 138 Bar (2000 PSI) Sizes 1 1/4" - 2" 103 Bar (1500 PSI) Saturated Steam up to 10 Bar (150 PSI) and 177°C (350°F) Vacuum service to 29 in. Hg
Body Material	CF-8M Stainless Steel 316 SS Cast Equivalent
Ball Material	Stainless Steel

Performance Curves

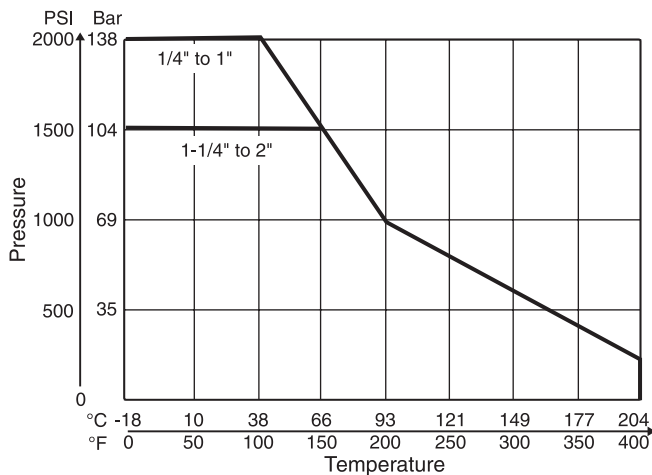

Flow Data

Type 501SS		Type 502SS	
Valve Size	C _v	Valve Size	C _v
1/4"	4.0	1/4"	4.0
3/8"	6.0	3/8"	6.0
1/2"	14.0	1/2"	14.0
3/4"	35.0	3/4"	35.0
1"	54.0	1"	54.0
		1-1/4"	74.0
		1-1/2"	120.0
		2"	226.0

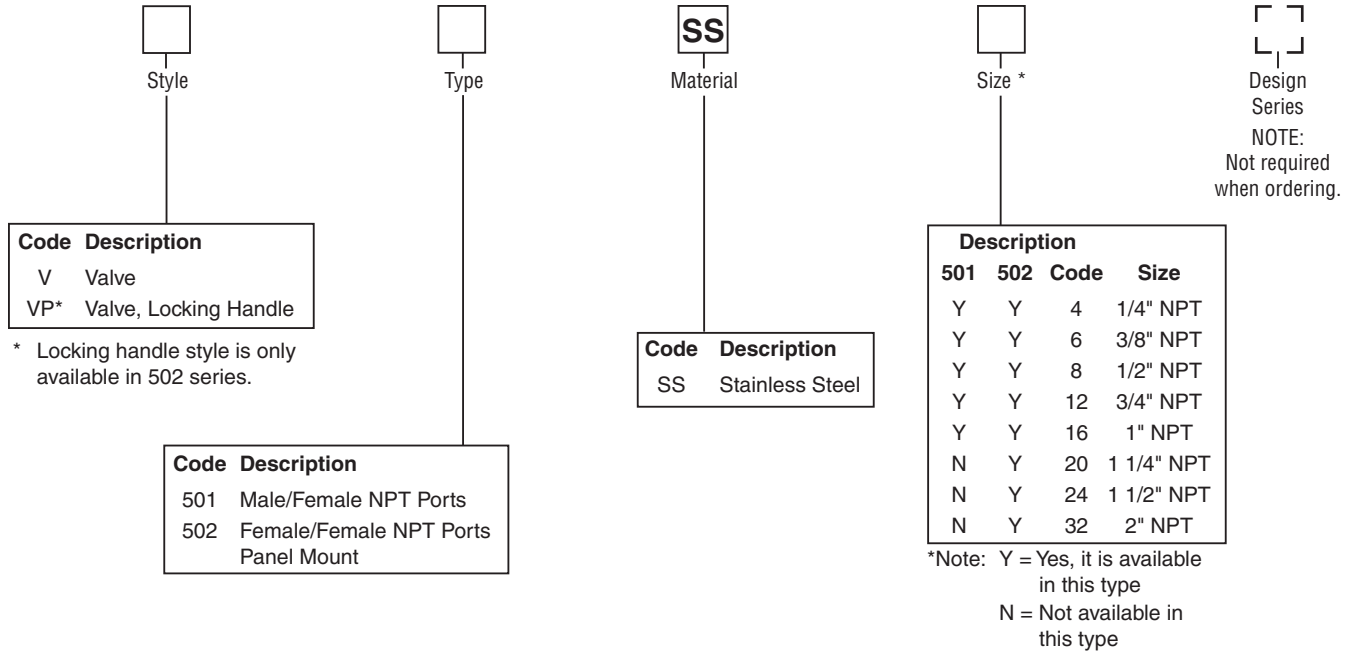

Mounting Detail

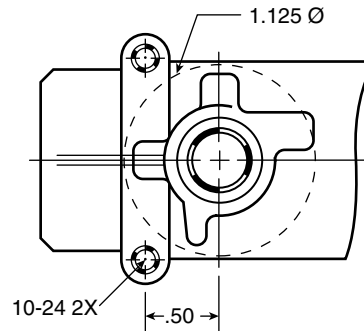

Model V501SS

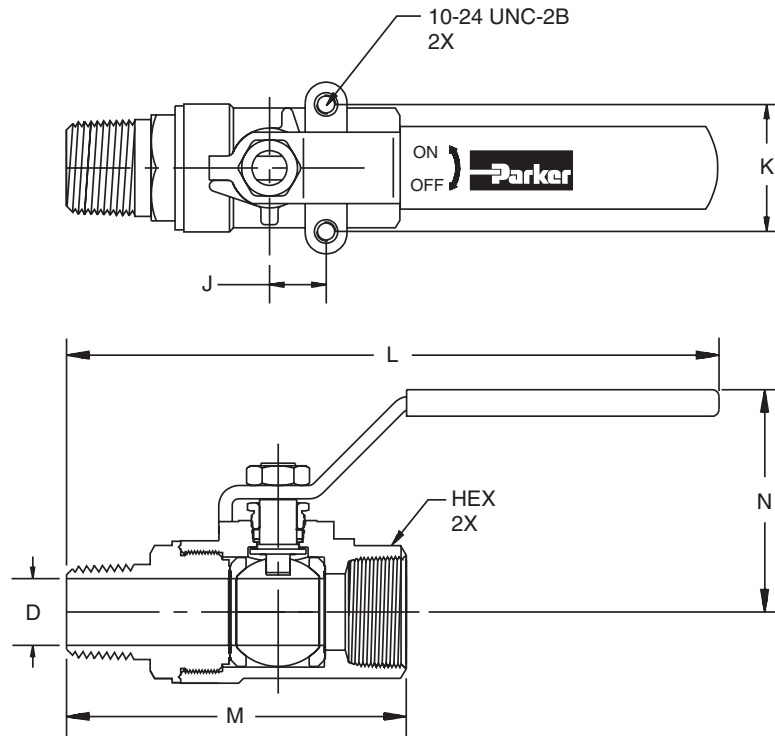

Part Number	Pipe Thread	Hex	Dimensions mm (in)					D Flow Ø
			J	K	L	M	N	
Male-Female Pipe Ends V501SS								
V501SS4	1/4"	15/16"	12.7 (0.50)	28.4 (1.12)	142.2 (5.60)	67.3 (2.65)	50.0 (1.97)	7.1 (0.280)
V501SS6	3/8"	15/16"	12.7 (0.50)	28.4 (1.12)	142.2 (5.60)	67.3 (2.65)	50.0 (1.97)	9.5 (0.375)
V501SS8	1/2"	1-1/16"	12.7 (0.50)	28.4 (1.12)	148.6 (5.85)	77.5 (3.05)	50.8 (2.00)	12.7 (0.500)
V501SS12	3/4"	1-3/8"	22.4 (0.88)	34.8 (1.37)	184.7 (7.27)	97.8 (3.85)	64.8 (2.55)	18.3 (0.720)
V501SS16	1"	1-5/8"	22.4 (0.88)	34.8 (1.37)	190.0 (7.48)	108.0 (4.25)	68.1 (2.68)	23.9 (0.940)

Model V502SS and VP502SS

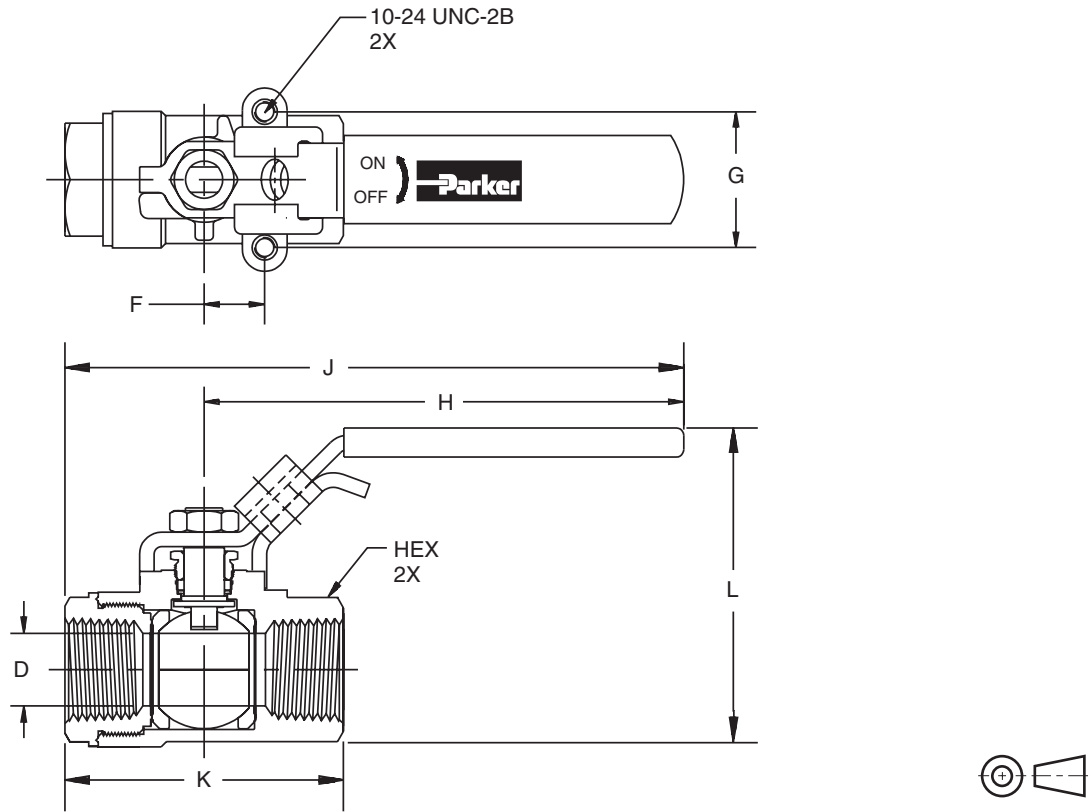

Part Number	Pipe Thread	Hex	Dimensions mm (in)						D Flow Ø	Panel Mount Thread
			F	G	H	J	K	L		
Female to Female Panel Mount										
V*502SS4	1/4"	15/16"	12.7 (0.50)	28.6 (1.13)	101.6 (4.00)	127.8 (5.03)	52.6 (2.07)	64.0 (2.52)	9.5 (0.38)	10-24 UNC
V*502SS6	3/8"	15/16"	12.7 (0.50)	28.6 (1.13)	101.6 (4.00)	127.8 (5.03)	52.6 (2.07)	64.0 (2.52)	9.5 (0.38)	10-24 UNC
V*502SS8	1/2"	1-1/16"	12.7 (0.50)	28.6 (1.13)	101.6 (4.00)	130.3 (5.13)	57.7 (2.27)	67.3 (2.65)	12.7 (0.50)	10-24 UNC
V*502SS12	3/4"	1-3/8"	22.2 (0.88)	34.9 (1.38)	127.0 (5.00)	169.4 (6.67)	85.1 (3.35)	87.9 (3.46)	20.1 (0.79)	10-24 UNC
V*502SS16	1"	1-5/8"	22.2 (0.88)	34.9 (1.38)	127.0 (5.00)	172.0 (6.77)	89.9 (3.54)	95.0 (3.74)	25.4 (1.00)	10-24 UNC
V*502SS20	1-1/4"	2"	25.4 (1.00)	38.1 (1.50)	177.8 (7.00)	228.6 (9.00)	101.6 (4.00)	115.6 (4.55)	31.8 (1.25)	1/4-20 UNC
V*502SS24	1-1/2"	2-3/8"	25.4 (1.00)	38.1 (1.50)	177.8 (7.00)	182.6 (7.19)	111.3 (4.38)	137.7 (5.42)	38.1 (1.50)	1/4-20 UNC
V*502SS32	2"	3"	25.4 (1.00)	38.1 (1.50)	177.8 (7.00)	247.7 (9.75)	139.7 (5.50)	144.3 (5.68)	50.8 (2.00)	1/4-20 UNC

Locking handle parts: For use with 5/16" diameter shank lock

General Description

Series 590 low pressure 90° ball valves provide total shut-off capability for services up to 17 Bar (250 PSI).

Operation

A quarter turn of the handle is on or off. Ball valves are not intended for use as a throttling valve. Attempting to use it in these applications may result in premature seal failure and/or inability to turn the valve handle.

Features

- Ball Valve bodies are machined from high quality CA377 forgings which provide extended service life and resist failure caused by severe temperature conditions.
- Highly inert PTFE seats and seals provide resistance to chemical corrosion.
- Blowout proof stem design, chrome plated brass ball and a special design handle enable increased turn and leverage for ease of opening and closing.

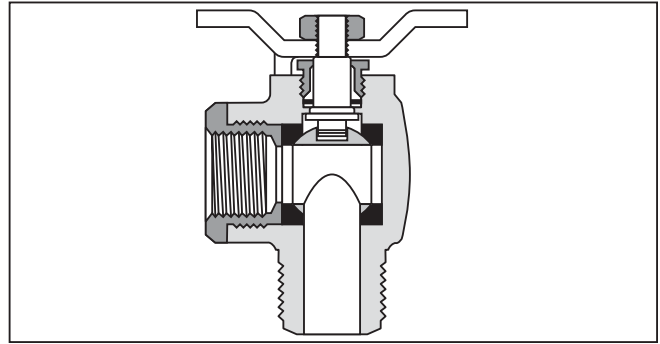
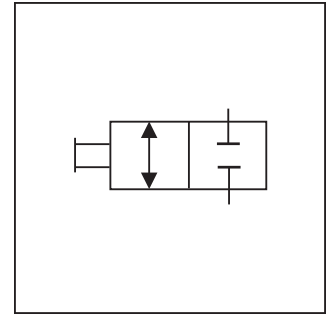

Specifications

Working Pressure	17 Bar (250 PSI)
-------------------------	------------------

Ordering Information

V
Style

□
Type

P
Material

□
Size

□
Design Series

NOTE:
Not required when ordering.

Code	Description
590	90° Male/Female NPT Ports
591	90° Male/Male NPT Ports

Code	Description
P	Brass

Code	Size
4	1/4" NPT
6	3/8" NPT
8	1/2" NPT

Performance Curve

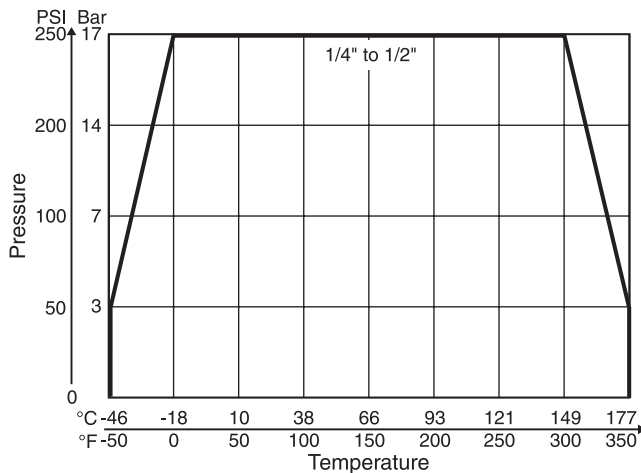

3300-ballvalves.indd, ddp

Model V590P

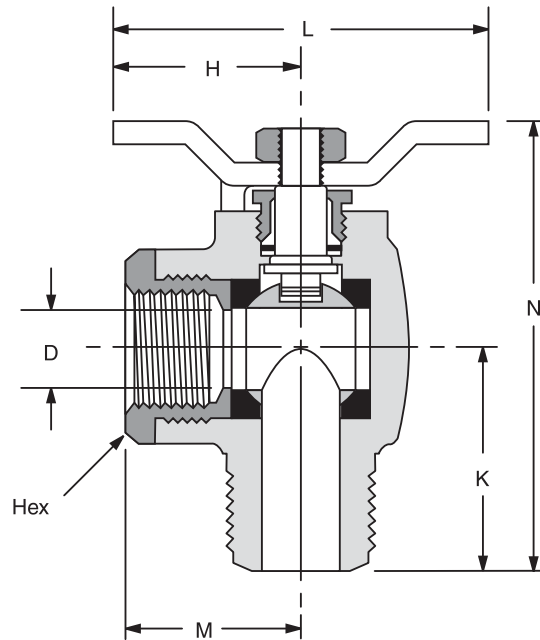

Part Number	Pipe Thread	Hex	Dimensions mm (in)					D Flow Ø
			H	K	L	M	N	
90° Flow, Male-Female Pipe Ends V590P								
V590P-4	1/4"	15/16"	31.8 (1.25)	27.4 (1.08)	63.5 (2.50)	25.4 (1.00)	61.5 (2.42)	9.5 (0.375)
V590P-6	3/8"	15/16"	31.8 (1.25)	27.7 (1.09)	63.5 (2.50)	25.4 (1.00)	61.7 (2.43)	9.5 (0.375)
V590P-8	1/2"	1-1/16"	31.8 (1.25)	33.0 (1.30)	63.5 (2.50)	27.4 (1.08)	67.8 (2.67)	12.7 (0.500)

Model V591P

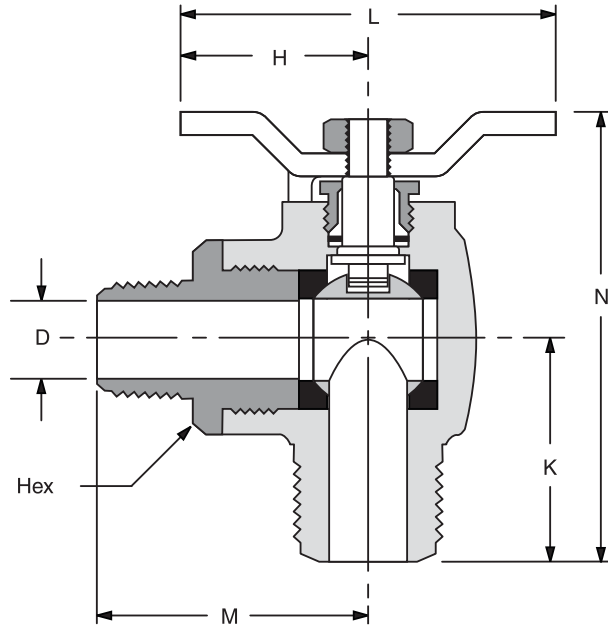

Part Number	Pipe Thread (PTF)	Hex	Dimensions mm (in)					D Flow Ø
			H	K	L	M	N	
90° Flow, Male-Female Pipe Ends V591P								
V591P-4	1/4"	15/16"	31.8 (1.25)	27.4 (1.08)	63.5 (2.50)	39.6 (1.56)	61.5 (2.42)	9.5 (0.375)
V591P-6	3/8"	15/16"	31.8 (1.25)	27.7 (1.09)	63.5 (2.50)	39.6 (1.56)	61.7 (2.43)	9.5 (0.375)
V591P-8	1/2"	1-1/16"	31.8 (1.25)	33.0 (1.30)	63.5 (2.50)	46.7 (1.84)	67.8 (2.67)	12.7 (0.500)

Terms of Sale with Warranty Limitations

Offer of Sale

The items described in this document and other documents and descriptions provided by Parker Hannifin Corporation, its subsidiaries and its authorized distributors ("Seller") are hereby offered for sale at prices to be established by Seller. This offer and its acceptance by any customer ("Buyer") shall be governed by all of the following Terms and Conditions. Buyer's order for any item described in its document, when communicated to Seller verbally, or in writing, shall constitute acceptance of this offer. All goods, services or work described will be referred to as "Products".

1. **Terms and Conditions.** Seller's willingness to offer Products, or accept an order for Products, to or from Buyer is subject to these Terms and Conditions or any newer version of the terms and conditions found on-line at www.parker.com/saleterms/. Seller objects to any contrary or additional terms or conditions of Buyer's order or any other document issued by Buyer.

2. **Price Adjustments; Payments.** Prices stated on Seller's quote or other documentation offered by Seller are valid for 30 days, and do not include any sales, use, or other taxes unless specifically stated. Unless otherwise specified by Seller, all prices are F.C.A. Seller's facility (INCOTERMS 2010). Payment is subject to credit approval and is due 30 days from the date of invoice or such other term as required by Seller's Credit Department, after which Buyer shall pay interest on any unpaid invoices at the rate of 1.5% per month or the maximum allowable rate under applicable law.

3. **Delivery Dates; Title and Risk; Shipment.** All delivery dates are approximate and Seller shall not be responsible for any damages resulting from any delay. Regardless of the manner of shipment, title to any products and risk of loss or damage shall pass to Buyer upon placement of the products with the shipment carrier at Seller's facility. Unless otherwise stated, Seller may exercise its judgment in choosing the carrier and means of delivery. No deferment of shipment at Buyers' request beyond the respective dates indicated will be made except on terms that will indemnify, defend and hold Seller harmless against all loss and additional expense. Buyer shall be responsible for any additional shipping charges incurred by Seller due to Buyer's acts or omissions.

4. **Warranty.** Seller warrants that the Products sold hereunder shall be free from defects in material or workmanship for a period of eighteen months from the date of delivery to Buyer. The prices charged for Seller's products are based upon the exclusive limited warranty stated above, and upon the following disclaimer: **DISCLAIMER OF WARRANTY: THIS WARRANTY COMPRISES THE SOLE AND ENTIRE WARRANTY PERTAINING TO PRODUCTS PROVIDED HEREUNDER. SELLER DISCLAIMS ALL OTHER WARRANTIES, EXPRESS AND IMPLIED, INCLUDING DESIGN, MERCHANTABILITY AND FITNESS FOR A PARTICULAR PURPOSE.**

5. **Claims; Commencement of Actions.** Buyer shall promptly inspect all Products upon delivery. No claims for shortages will be allowed unless reported to the Seller within 10 days of delivery. No other claims against Seller will be allowed unless asserted in writing within 30 days after delivery. Buyer shall notify Seller of any alleged breach of warranty within 30 days after the date the defect is or should have been discovered by Buyer. Any action based upon breach of this agreement or upon any other claim arising out of this sale (other than an action by Seller for an amount due on any invoice) must be commenced within 12 months from the date of the breach without regard to the date breach is discovered.

6. **LIMITATION OF LIABILITY.** UPON NOTIFICATION, SELLER WILL, AT ITS OPTION, REPAIR OR REPLACE A DEFECTIVE PRODUCT, OR REFUND THE PURCHASE PRICE. IN NO EVENT SHALL SELLER BE LIABLE TO BUYER FOR ANY SPECIAL, INDIRECT, INCIDENTAL OR CONSEQUENTIAL DAMAGES ARISING OUT OF, OR AS THE RESULT OF, THE SALE, DELIVERY, NON-DELIVERY, SERVICING, USE OR LOSS OF USE OF THE PRODUCTS OR ANY PART THEREOF, OR FOR ANY CHARGES OR EXPENSES OF ANY NATURE INCURRED WITHOUT SELLER'S WRITTEN CONSENT, EVEN IF SELLER HAS BEEN NEGLIGENT, WHETHER IN CONTRACT, TORT OR OTHER LEGAL THEORY. IN NO EVENT SHALL SELLER'S LIABILITY UNDER ANY CLAIM MADE BY BUYER EXCEED THE PURCHASE PRICE OF THE PRODUCTS.

7. **User Responsibility.** The user, through its own analysis and testing, is solely responsible for making the final selection of the system and Product and assuring that all performance, endurance, maintenance, safety and warning requirements of the application are met. The user must analyze all aspects of the application and follow applicable industry standards and Product information. If Seller provides Product or system options, the user is responsible for determining that such data and specifications are suitable and sufficient for all applications and reasonably foreseeable uses of the Products or systems.

8. **Loss to Buyer's Property.** Any designs, tools, patterns, materials, drawings, confidential information or equipment furnished by Buyer or any other items which become Buyer's property, will be considered obsolete and may be destroyed by Seller after two consecutive years have elapsed without Buyer ordering the items manufactured using such property. Seller shall not be responsible for any loss or damage to such property while it is in Seller's possession or control.

9. **Special Tooling.** A tooling charge may be imposed for any special tooling, including without limitation, dies, fixtures, molds and patterns, acquired to manufacture Products. Such special tooling shall be and remain Seller's property notwithstanding payment of any charges by Buyer. In no event will Buyer acquire any interest in apparatus belonging to Seller which is utilized in the manufacture of the Products, even if such apparatus has been specially converted or adapted for such manufacture and notwithstanding any charges paid by Buyer. Unless otherwise agreed, Seller shall have the right to alter, discard or otherwise dispose of any special tooling or other property in its sole discretion at any time.

10. **Buyer's Obligation; Rights of Seller.** To secure payment of all sums due or otherwise, Seller shall retain a security interest in the goods delivered and this agreement shall be deemed a Security Agreement under the Uniform Commercial Code. Buyer authorizes Seller as its attorney to execute and file on Buyer's behalf all documents Seller deems necessary to perfect its security interest.

11. **Improper Use and Indemnity.** Buyer shall indemnify, defend, and hold Seller harmless from any claim, liability, damages, lawsuits, and costs (including attorney fees), whether for personal injury, property damage, patent, trademark or copyright

infringement or any other claim, brought by or incurred by Buyer, Buyer's employees, or any other person, arising out of: (a) improper selection, improper application or other misuse of Products purchased by Buyer from Seller; (b) any act or omission, negligent or otherwise, of Buyer; (c) Seller's use of patterns, plans, drawings, or specifications furnished by Buyer to manufacture Product; or (d) Buyer's failure to comply with these terms and conditions. Seller shall not indemnify Buyer under any circumstance except as otherwise provided.

12. **Cancellations and Changes.** Orders shall not be subject to cancellation or change by Buyer for any reason, except with Seller's written consent and upon terms that will indemnify, defend and hold Seller harmless against all direct, incidental and consequential loss or damage. Seller may change product features, specifications, designs and availability with notice to Buyer.

13. **Limitation on Assignment.** Buyer may not assign its rights or obligations under this agreement without the prior written consent of Seller.

14. **Force Majeure.** Seller does not assume the risk and shall not be liable for delay or failure to perform any of Seller's obligations by reason of circumstances beyond the reasonable control of Seller (hereinafter "Events of Force Majeure"). Events of Force Majeure shall include without limitation: accidents, strikes or labor disputes, acts of any government or government agency, acts of nature, delays or failures in delivery from carriers or suppliers, shortages of materials, or any other cause beyond Seller's reasonable control.

15. **Waiver and Severability.** Failure to enforce any provision of this agreement will not waive that provision nor will any such failure prejudice Seller's right to enforce that provision in the future. Invalidation of any provision of this agreement by legislation or other rule of law shall not invalidate any other provision herein. The remaining provisions of this agreement will remain in full force and effect.

16. **Termination.** Seller may terminate this agreement for any reason and at any time by giving Buyer thirty (30) days written notice of termination. Seller may immediately terminate this agreement, in writing, if Buyer: (a) commits a breach of any provision of this agreement (b) appoints a trustee, receiver or custodian for all or any part of Buyer's property (c) files a petition for relief in bankruptcy on its own behalf, or by a third party (d) makes an assignment for the benefit of creditors, or (e) dissolves or liquidates all or a majority of its assets.

17. **Governing Law.** This agreement and the sale and delivery of all Products hereunder shall be deemed to have taken place in and shall be governed and construed in accordance with the laws of the State of Ohio, as applicable to contracts executed and wholly performed therein and without regard to conflicts of laws principles. Buyer irrevocably agrees and consents to the exclusive jurisdiction and venue of the courts of Cuyahoga County, Ohio with respect to any dispute, controversy or claim arising out of or relating to this agreement.

18. **Indemnity for Infringement of Intellectual Property Rights.** Seller shall have no liability for infringement of any patents, trademarks, copyrights, trade dress, trade secrets or similar rights except as provided in this Section. Seller will defend and indemnify Buyer against allegations of infringement of U.S. patents, U.S. trademarks, copyrights, trade dress and trade secrets ("Intellectual Property Rights"). Seller will defend at its expense and will pay the cost of any settlement or damages awarded in an action brought against Buyer based on an allegation that a Product sold pursuant to this Agreement infringes the Intellectual Property Rights of a third party. Seller's obligation to defend and indemnify Buyer is contingent on Buyer notifying Seller within ten (10) days after Buyer becomes aware of such allegations of infringement, and Seller having sole control over the defense of any allegations or actions including all negotiations for settlement or compromise. If a Product is subject to a claim that it infringes the Intellectual Property Rights of a third party, Seller may, at its sole expense and option, procure for Buyer the right to continue using the Product, replace or modify the Product so as to make it noninfringing, or offer to accept return of the Product and return the purchase price less a reasonable allowance for depreciation. Notwithstanding the foregoing, Seller shall have no liability for claims of infringement based on information provided by Buyer, or directed to Products delivered hereunder for which the designs are specified in whole or part by Buyer, or infringements resulting from the modification, combination or use in a system of any Product sold hereunder. The foregoing provisions of this Section shall constitute Seller's sole and exclusive liability and Buyer's sole and exclusive remedy for infringement of Intellectual Property Rights.

19. **Entire Agreement.** This agreement contains the entire agreement between the Buyer and Seller and constitutes the final, complete and exclusive expression of the terms of sale. All prior or contemporaneous written or oral agreements or negotiations with respect to the subject matter are herein merged.

20. **Compliance with Law, U. K. Bribery Act and U.S. Foreign Corrupt Practices Act.** Buyer agrees to comply with all applicable laws and regulations, including both those of the United Kingdom and the United States of America, and of the country or countries of the Territory in which Buyer may operate, including without limitation the U. K. Bribery Act, the U.S. Foreign Corrupt Practices Act ("FCPA") and the U.S. Anti-Kickback Act (the "Anti-Kickback Act"), and agrees to indemnify and hold harmless Seller from the consequences of any violation of such provisions by Buyer, its employees or agents. Buyer acknowledges that they are familiar with the provisions of the U. K. Bribery Act, the FCPA and the Anti-Kickback Act, and certifies that Buyer will adhere to the requirements thereof. In particular, Buyer represents and agrees that Buyer shall not make any payment or give anything of value, directly or indirectly to any governmental official, any foreign political party or official thereof, any candidate for foreign political office, or any commercial entity or person, for the purpose of influencing such person to purchase products or otherwise benefit the business of Seller.

02/12



Parker Safety Guide for Selecting and Using Hydraulic Valves and Related Accessories

WARNING: Failure or improper selection or improper use of Parker Hydraulic Valve Division (HVD) Valves or related accessories (“Products”) can cause death, personal injury and property damage. Possible consequences of failure or improper use of these Products include but are not limited to:

- Valves or parts thereof thrown off at high speed
- High velocity fluid discharge
- Explosion or burning of the conveyed fluid
- Contact with suddenly moving or falling objects controlled by the Valve
- Injections by high-pressure fluid discharge
- Contact with fluid that may be hot, cold, toxic or otherwise injurious
- Injuries resulting from injection, inhalation or exposure to fluids
- Injury from handling a heavy item (dropped, awkward lift)
- Electric shock from improper handling of solenoid connections
- Injury from slip or fall on spilled or leaked fluid

Before selecting or using any of these Products, it is important that you read and follow the instructions below. In general, the Products are not approved for in-flight aerospace applications. Consult the factory for the few that are FAA approved.

1.0 GENERAL INSTRUCTIONS

- 1.1 **Scope:** This safety guide provides instructions for selecting and using (including assembling, installing and maintaining) these Products. For convenience all items in this guide are called “Valves”. This safety guide is a supplement to and is to be used in conjunction with the specific Parker catalogs for the specific Valves and/or accessories being considered for use. See item 1.6 below for obtaining those catalogs.
- 1.2 **Fail-Safe:** Valves can and do fail without warning for many reasons. Design all systems and equipment in a fail-safe mode, so that failure of the Valve or Valve Assembly will not endanger persons or property.
- 1.3 **Safety Devices:** Never disconnect, override, circumvent or otherwise disable any safety lockout on any system whether powered by HVD Valves or any motion control system of any manufacturer. (e.g. Automatic shut-off on a riding lawn mower should the operator get out of the seat).
- 1.4 **Distribution:** Provide a copy of this safety guide to each person that is responsible for selecting or using HVD Valve Products. Do not select HVD Valves without thoroughly reading and understanding this safety guide as well as the specific Parker catalogs for the Products considered or selected.
- 1.5 **User Responsibility:** Due the wide variety of operating conditions and applications for Valves, HVD and its distributors do not represent or warrant that any particular Valve is suitable for any specific system. This safety guide does not analyze all technical parameters that must be considered in selecting a product. The user, through its own analysis and testing is solely responsible for:
 - Making the final selection of the Valve
 - Assuring that the user’s requirements are met and that the application presents no health or safety hazards.
 - Providing all appropriate health and safety warnings on the equipment on which the Valves are used.
 - Assuring compliance with all applicable government and industry standards.
- 1.6 **Additional Questions:** Call the appropriate Parker technical service department if you have any questions or require any additional information. See the Parker publication for the product being considered or used, or call 1-800-CPARKER, or go to www.parker.com, for the telephone numbers of the appropriate technical service department. For additional copies of this or any other Parker Safety Guide go to www.parker.com and click on the safety button on the opening page. Catalogs and/or catalog numbers for the various HVD Valve Products can be obtained by calling HVD at 440-366-5100. Phone numbers and catalog information is also available on the Parker website, www.parker.com.

2.0 VALVE SELECTION INSTRUCTIONS

- 2.1 **Pressure:** Valve selection must be made so that the maximum working pressure of the Valve is equal to or greater than the maximum system pressure. Surge, impulse or peak transient pressures in the system must be below the maximum working pressure of the Valve. Surge, impulse and peak pressures can usually be determined by sensitive electrical instrumentation that measures and indicates pressures at millisecond intervals. Mechanical pressure gauges indicate only average pressure and cannot be used to determine surge, impulse or peak transient pressures. Burst pressure ratings if given or known are for manufacturing purposes only and are not an indication that the Product can be used in applications at the burst pressure or otherwise above the maximum working pressure.
- 2.2 **Temperature:** The fluid temperature must be regulated or controlled so that the operating viscosity of the fluid is maintained at a level specified for the particular Valve product. Such ranges are given in the product catalogs or can be obtained from the appropriate customer service department for the particular Valve product.
- 2.3 **Fluid Compatibility:** The fluid conveyed in Valves has direct implications on the Valve selection. The fluid must be chemically compatible with the Valve component materials. Elastomer seals, brass, cast iron, aluminum for example all are potentially affected by certain fluids. Additionally, fluid selection affects the performance of various Valves. Considerations relative to fluid selection are outlined in the specific HVD Valve product catalog. Of particular importance is that the fluid be for hydraulic use, contain the proper additives and wear inhibitors. See 1.6 “Additional Questions” above for information to obtain such HVD catalogs.
- 2.4 **Changing Fluids:** If a system requires a different fluid, it should be done with the guidance in number 2.3 above. Additionally, it may be necessary to flush the system (including the Valves) to remove any of the previous fluid. Consult the Parker Valve Division for guidance.
- 2.5 **Size:** Transmission of power by means of pressurized fluid varies with pressure and rate of flow. The size of the components must be adequate to keep pressure losses to a minimum and avoid damage due to heat generation or excessive fluid velocity.
- 2.6 **Placement:** Installation of Valves must take into account the orientation of the Valve and the proximity of the Valve to other parts of the system. This includes but is not limited to closeness to hot and cold areas, access for servicing and operation as well as orientation for proper connectors.
- 2.7 **Ports:** Connection of Valves in systems can be by threaded ports, sub-base surfaces, flanges and manifolds. In all cases, the proper fitting, surface or mounting hardware must be selected to properly seal and contain the system fluid so as to avoid the adverse conditions listed in the initial warning box above. Specifically, if using threaded ports, the designer must make sure that the mating fitting is of the compatible thread. Also, the instructions provided by the connector hardware supplier must be read and understood so as to properly assemble the connector. The Parker Safety Guide for using Hose, Tubing and Fittings and Related Accessories is but one reference to this end.
- 2.8 **Environment:** Care must be taken to insure that the Valve and Valve Assemblies are either compatible with or protected from the environment (that is, surrounding conditions) to which they are exposed. Environmental conditions including but not limited to ultraviolet radiation, sunlight, heat, ozone, moisture, water, salt water, chemicals and air pollutants can cause degradation and premature failure.
- 2.9 **Electric Power:** For Valves requiring electric power for control, it is imperative that the electricity be delivered at the proper voltage, current and wattage requirements. To obtain the proper control requirements please refer to the respective Parker product catalog for the specific Valve that is intended for use. If further guidance is required, call the appropriate technical service department identified in the respective Parker product catalog.
- 2.10 **Specifications and Standards:** When selecting Valves, government, industry and Parker specifications and recommendations must be reviewed and followed as applicable.
- 2.11 **Accessories:** All accessories used in conjunction with any Parker Valve product must be rated to the same requirements of the Valve including but not limited to pressure, flow, material compatibility, power requirements. All of these items must be examined as stated in the “VALVE INSTALLATION INSTRUCTIONS” paragraph 3.0.

3.0 VALVE INSTALLATION INSTRUCTIONS

- 3.1 **Component Inspection:** Prior to use, a careful examination of the Valve(s) must be performed. The Valve intended for use must be checked for correct style, size, catalog number and external condition. The Valve must be examined for cleanliness, absence of external defects or gouges, cracked or otherwise deformed parts or missing items. The mounting surface or port connections must be protected and free of burrs, scratches, corrosion or other imperfections. Do NOT use any item that displays any signs of nonconformance. In addition, any accessory including but not limited to fittings, bolt kits, hoses, sub bases, manifolds, and electrical connectors must be subjected to the same examination.
- 3.2 **Handling Valves:** Many Valves whether HVD Valves or of another manufacturer can be large, bulky or otherwise difficult to handle. Care must be taken to use proper lifting techniques, tools, braces, lifting belts or other aids so as not to cause injury to the user, any other person or to property.
- 3.3 **Filtration:** Fluid cleanliness is a necessity in any hydraulic system. Fluid filters must be installed and maintained in the system to provide the required level of fluid cleanliness. Filters can be placed in the inlets, pressure lines and return lines. The level of cleanliness required is specified in the HVD product catalog for the specific Valve(s) selected or intended for use. For additional information on Filter selection contact Parker Filter Division at 800-253-1258 or 419-644-4311.
- 3.4 **Servo Valves:** Application of Servo Valves in general requires knowledge and awareness of “closed loop control theory” and the use of electronic controls for successful and safe operation. Individuals who do not have such experience or knowledge must gain training before use of such Products. Parker offers both classroom training as well as manuals to assist in gaining this knowledge. These aids can be obtained by contacting Hydraulic Valve Division at 440-366-5100, calling the general Parker help line 800-CPARKER or going to the Parker web site at www.parker.com.
- 3.5 **Accessory Ratings:** All accessories used in combination with the selected or intended Valve product must be rated and compatible with the selected Valve. Specifically, the items must be of equal or greater rating including but not limited to pressure, flow, power, size, port style, thread connectors and material.
- 3.6 **Connection Styles:** It is the responsibility of the user of the Parker product to properly select connectors and accessories that match the connections on the sub plate, Valve, flange or threaded connection or manifold. It is also the responsibility of the installer to possess adequate skill and knowledge including but not limited to thread preparation, torque technique, hose assembly and inspection, tube preparation and assembly, and fitting installation. Parker Tube Fitting Division (www.parker.com/tfd) catalog 4300 and Parker Hose Products (www.parkerhose.com) catalog 4400 describe some basic technical information relative to proper fitting assembly.
- 3.7 **Electrical Connections:** All electrical connections must be made to the applicable codes and local safety requirements.
- 3.8 **Gauges and Sensors:** The user must install sufficient gauges and sensors in the system so as to be able to determine the condition of the system. This includes but is not limited to pressure gauges, flow meters, temperature sensors and site gauges. These are of utmost importance should removal or disassembly of a Valve, portion of a Valve or portion of the system become necessary. Refer to “VALVE MAINTENANCE AND REPLACEMENT INSTRUCTIONS” for details and especially item 4.8.
- 3.9 **System Checkout:** Once installed, the Valve installation must be tested to insure proper operation and that no external leakage exists. All safety equipment must be in place including but not limited to safety glasses, helmets, ear protection, splash guards, gloves, coveralls and any shields on the equipment. All air entrapment must be eliminated and the system pressurized to the maximum system pressure (at or below the Valve maximum working pressure) and checked for proper function and freedom from leaks. Personnel must stay out of potentially hazardous areas while testing and using.

4.0 VALVE MAINTENANCE AND REPLACEMENT INSTRUCTIONS

- 4.1 **Maintenance Program:** Even with proper installation, Valves and Valve System life may be significantly reduced without a continuing maintenance program. The severity of the application and risk potential must determine the frequency of the inspection and the replacement of the Products so that Products are replaced before any failure occurs. A maintenance program must be established and followed by the user and, at a minimum, must include instructions 4.2 through 4.10. An FMEA (Failure Mode and Effects Analysis) is recommended in determining maintenance requirements.
- 4.2 **Visual Inspection-Valves:** Any of the following conditions require immediate shut down and replacement of the Valve.
- Evidence that the Valve is in partial dis-assembly.
 - Visible crack or suspicion of a crack in the Valve housing or bent, cracked or otherwise damaged solenoid.
 - Missing or partially extending drive pin on a flow control knob.
 - Missing, loose components, obstructions or other condition impeding the motion or function of the manual knob, lever, foot pedal or other mechanical operator of a hydraulic Valve.
 - Any evidence of burning or heat induced discoloration.
 - Blistered, soft, degraded or loose cover of any kind.
 - Loose wire or electrical connector.
- 4.3 **Visual Inspection-Other:** The following conditions must be tightened, repaired, corrected or replaced as required.
1. Fluid on the ground must be cleaned immediately. Also, the source of the fluid must be determined prior to running the equipment again.
 2. Leaking port or excessive external dirt build-up.
 3. System fluid level is too low or air is entrapped or visible in the reservoir.
 4. Equipment controlled by the Valve or Valve assembly has been losing power, speed, efficiency
- 4.4 **Filter Maintenance:** System filters must be maintained and kept in proper working order. The main service requirement is periodic replacement of the filter element or screen. Contact Parker Filter Division at 800-253-1258 or 419-644-4311 for further filter maintenance details.
- 4.5 **Functional Test:** See “System Checkout” number 3.9 above in “VALVE INSTALLATION INSTRUCTIONS”.
- 4.6 **Replacement Intervals:** Valves and Valve Systems will eventually age and require replacement. Seals especially should be inspected and replaced at specific replacement intervals based on previous experience, government or industry recommendations, or when failures could result in unacceptable downtime, damage or injury risk. At a minimum seals must be replaced whenever service is rendered to a Valve product.
- 4.7 **Adjustments, Control Knobs, and Other Manual Controls:** System Pressure and Flow are typically adjusted by knobs and/or handles. A set-screw or lock-nut secures the adjustment device so as to maintain the desired setting. This set-screw or lock-nut must first be loosened prior to making any adjustments and re-tightened after adjustment on the HVD Valve. All adjustments must be made in conjunction with pressure gauges and/or flow meters (or by watching the speed of the actuator in the case of setting flow only). See paragraph “Gauges and Sensors” above in the section “VALVE INSTALLATION INSTRUCTIONS”. Under no circumstances should any control knob, adjustment stem, handle, foot pedal or other actuating device be forced beyond the mechanical stop(s) on the Valve. For example, the Parker Safety Notice Bulletin **HY14-3310-B1/US** for HVD Colorflow Valves specifically restricts the adjustment torque to “hand adjust” or “less than 10 ft/lbs” if it cannot be adjusted by hand. Failure to adhere to this may force the knob beyond the stop point allowing it to be ejected at high speed resulting in death, personal injury and property damage. For complete safety instructions on HVD Colorflow Valves, copies of Safety Notice **Bulletin HY14-3310-B1/US** can be obtained directly from the Hydraulic Valve Division at 440-366-5100 or from the Parker web site at www.parker.com by selecting the “Safety” button. Parker help line 800-CPARKER is on call 24/7 as well should there be any question about the use of a HVD Valve. Additionally, when making adjustments, always adjust the Valve with all parts of your body to the side of the Valve (that is, the knob is not pointing toward you or anyone else).
- 4.8 **High pressure Warning:** Hydraulic power is transmitted by high-pressure fluids through hoses, fittings and valves, pumps and actuators. This condition can be dangerous and potentially lethal and, therefore, extreme caution must be exercised when working with fluids under pressure. From time to time, hoses, Valves, tubes or fittings fail if they are not replaced at proper time intervals. Typically these failures are the result of some form of misapplication, abuse, wear, or failure to perform proper maintenance. When such failure occurs, generally the high pressure fluid inside escapes in a stream which may or may not be visible to the user. Under no circumstances should the user attempt to locate the leak by “feeling” with their hands or any other part of their body. High-pressure fluids can and will penetrate the skin and cause severe tissue damage and possible loss of limb or life. Even seemingly minor hydraulic fluid injection injuries must be treated immediately by a physician with knowledge of the tissue damaging properties of hydraulic fluid. If a hose, tube, fitting or Valve failure occurs, immediately shut down the equipment and leave the area until pressure has been completely released from the system. Simply shutting down the pump may or may not eliminate the pressure in the system. It may take several minutes or even hours for the pressure to be relieved so that the leak area can be examined safely. Once the pressure has been reduced to zero, the suspected leaking item can be taken off the equipment and examined. It must always be replaced if a failure has occurred. Never attempt to patch or repair a connector (especially a hose) or Valve that has failed. Consult the nearest Parker distributor or the appropriate Parker division for component replacement information. Never touch or examine a failed hydraulic component unless it is obvious that the item no longer contains fluid under pressure.

Extensive Hydraulic Product Offering

Accumulators



Piston, bladder and diaphragm type accumulators, gas bottles and KleenVent reservoir isolators.

www.parker.com/accumulator

Compact Hydraulics



Self-contained with a motor, gear pump, reservoir, internal valving, load hold checks and relief valves.

www.parker.com/oildyne

Cylinders



Standard and custom hydraulic cylinders for industrial and mobile applications.

www.parker.com/hydcyl

Electronics/Remote Controls



Parker's unique IQAN approach combines sturdy, well-tested hardware with intelligent, flexible computing power.

www.parker.com/iqan

Filtration



Pressure and return line filters enhances machine life, reduces maintenance and lowers costs.

www.parker.com/hydraulicfilter

Integrated Hydraulic Circuits

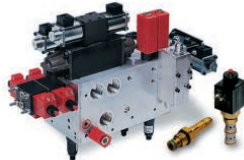

Solutions for complex circuits that include threaded cartridge valves integrated into a single manifold.

www.parker.com/hcs

Motors



Full line of high and low speed motors provides power up to 15,000 in-lbs of torque.

www.parker.com/pumpmotor

Power Take Off



Parker Chelsea leads the industry for engineering, innovation and performance in auxiliary power systems.

www.parker.com/chelsea

Power Units



The most complete line of standard, pre-engineered, cataloged hydraulic power units in the industry.

www.parker.com/pumpmotor

Pumps



Broad line of energy-efficient hydraulic pumps that includes piston, vane and gear pumps.

www.parker.com/mobpump

Rotary Actuator



Industry leader in the design and manufacture of hydraulic rack and pinion, and vane style rotary actuators.

www.parker.com/actuator

Valves and Controls



Hydraulic valves for virtually every hydraulic equipment application, from simple to precise control.

www.parker.com/hydraulicvalve

Covering the Industrial and Mobile markets, each catalog is paired with an interactive DVD. Call for your comprehensive guides today. 1-800-C-Parker.



Mobile Hydraulics
Bulletin HY19-1012/US



Industrial Hydraulics
Bulletin HY01-1001/US

Parker Hydraulics International Sales Offices

North America

Hydraulics Group Headquarters

6035 Parkland Boulevard
Cleveland, OH 44124-4141 USA
Tel: 216-896-3000
Fax: 216-896-4031

Parker Canada Division

160 Chisholm Drive
Milton, Ontario, L9T 3G9 Canada
Tel: 905-693-3000
Fax: 905-876-1958

Mexico

Parker Hannifin de México

Industrial Hydraulic Sales
Eje Uno Norte No. 100
Parque Industrial Toluca 2000
Toluca, Edo. de Mexico CP 50100
Tel: 52 72 2275 4200
Fax: 52 72 2279 9308

Europe

Hydraulics Group Headquarters

La Tuilière 6
CH-1163 Etoy, Switzerland
Tel: 41 21 821 8500
Fax: 41 21 821 8580

Latin America

Parker Hannifin Ind. e Com. Ltda Hydraulics Division

Av. Frederico Ritter, 1100
94930-000 Cachoeirinha RS, Brazil
Tel: 55 51 3470 9144
Fax: 55 51 3470 9215

Parker Hannifin Argentina S.A.I.C.

Stephenson 2711
1667-Tortuguitas-Malvinas Argentinas
Pcia. de Buenos Aires, Argentina
Tel: 54 3327 44 4129
Fax: 54 3327 44 4199

Pan American Division

7400 NW 19th Street, Suite A
Miami, FL 33126 USA
Tel: 305-470-8800
Fax: 305-470-8808

Industrial Sales

Central Region

1042 Maple Avenue
Unit 331
Lisle, IL 60532 USA
Tel: 630-964-0796

Great Lakes Region

6035 Parkland Boulevard
Cleveland, OH 44124-4141 USA
Tel: 216-896-3000
Fax: 216-896-4031

Gulf Region

20002 Standing Cypress Drive
Spring, TX 77379 USA
Tel: 817-473-4431
Fax: 888-227-9454

Southwest Region

700 S. 4th Avenue
Mansfield, TX 76063 USA
Tel: 817-473-4431
Fax: 888-227-9454

Mid Atlantic & Southeast Regions

1225 Old Alpharetta Rd
Suite 290
Alpharetta, GA 30005 USA
Tel: 770-619-9767
Fax: 770-619-9806

Midwest Region

8145 Lewis Road
Minneapolis, MN 55427 USA
Tel: 763-513-3535
Fax: 763-544-3418

Northeast Region

P.O. Box 396
Pine Brook, NJ 07058 USA
Tel: 973-227-2565
Fax: 973-227-2467

Northwest Region

6458 North Basin Avenue
Portland, OR 97217 USA
Tel: 503-283-1020
Fax: 866-611-7308

Pacific and Plains Region

8460 Kass Drive
Buena Park, CA 90621 USA
Tel: 714-228-2509
Fax: 714-228-2511

Mobile Sales

Mobile Sales Organization and Global Sales

850 Arthur Avenue
Elk Grove Village, IL 60007 USA
Tel: 847-258-6200
Fax: 847-258-6299

Asia Pacific

Parker Hannifin Shanghai Ltd.

280 Yunqiao Road,
Jin Qiao Export Processing Zone
Shanghai 201206, China
Tel: 86 21 2899 5000
Fax: 86 21 5834 8975

Parker Hannifin Hong Kong Ltd.

Suites 01-04, 20/F,
Tower 2, The Gateway,
Harbour City, Tsimshatsui,
Hong Kong
Tel: 852 2428 8008
Fax: 852 2480 4256

Parker Hannifin Korea Ltd.

18F KAMCO Yangjae Tower
949-3 Dogok1-dong, Gangnam-gu
Seoul, 135-860, Korea
Tel: 82 2 559 0408
Fax: 82 2 556 8187

Parker Hannifin India Pvt Ltd.

Plot No. EL-26, MIDC,
TTC Industrial Area
Mahape, Navi Mumbai, 400 709, India
Tel: 91 22 6513 7081
Fax: 91 22 2768 6841

Parker Hannifin Australia

Parker Hannifin Pty Ltd.
9 Carrington Road
Castle Hill, NSW 2154, Australia
Tel: 612 9634 7777
Fax: 612 9842 5111

South Africa

Parker Hannifin Africa Pty Ltd

10 Berne Avenue
Aeroporto
Kempton Park 1620,
Republic of South Africa
Tel: 19 610 700
Fax: 13 927 213



Parker Hannifin Corporation

Hydraulic Valve Division

520 Ternes Avenue
Elyria, Ohio 44035 USA
Tel: 440-366-5100
Fax: 440-366-5253

www.parker.com/hydraulicvalve