



**MAXE™
ROTARY SCREW LIQUID CHILLERS**

INSTALLATION, OPERATION & MAINTENANCE

Supersedes: NOTHING

Form 160.81-NOM2 (605)

**MODELS
YR TB TB T0 THROUGH YR VD VD T1
YR TB TB T0 THROUGH YR XD XD T3
INCLUDING
FIELD RE-ASSEMBLY FOR FORM 2, 3, 7 & 8 SHIPMENT
(STYLE C)**



00562VIP

R-134a



Metric Conversions



IMPORTANT!

READ BEFORE PROCEEDING!

GENERAL SAFETY GUIDELINES

This equipment is a relatively complicated apparatus. During installation, operation, maintenance or service, individuals may be exposed to certain components or conditions including, but not limited to: refrigerants, oils, materials under pressure, rotating components, and both high and low voltage. Each of these items has the potential, if misused or handled improperly, to cause bodily injury or death. It is the obligation and responsibility of operating/service personnel to identify and recognize these inherent hazards, protect themselves, and proceed safely in completing their tasks. Failure to comply with any of these requirements could result in serious damage to the equipment and the property in

which it is situated, as well as severe personal injury or death to themselves and people at the site.

This document is intended for use by owner-authorized operating/service personnel. It is expected that this individual possesses independent training that will enable them to perform their assigned tasks properly and safely. It is essential that, prior to performing any task on this equipment, this individual shall have read and understood this document and any referenced materials. This individual shall also be familiar with and comply with all applicable governmental standards and regulations pertaining to the task in question.

SAFETY SYMBOLS

The following symbols are used in this document to alert the reader to areas of potential hazard:



DANGER indicates an imminently hazardous situation which, if not avoided, will result in death or serious injury.



CAUTION identifies a hazard which could lead to damage to the machine, damage to other equipment and/or environmental pollution. Usually an instruction will be given, together with a brief explanation.



WARNING indicates a potentially hazardous situation which, if not avoided, could result in death or serious injury.

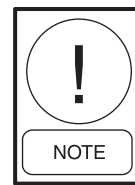

NOTE is used to highlight additional information which may be helpful to you.

CHANGEABILITY OF THIS DOCUMENT

In complying with YORK's policy for continuous product improvement, the information contained in this document is subject to change without notice. While YORK makes no commitment to update or provide current information automatically to the manual owner, that information, if applicable, can be obtained by contacting the nearest YORK Engineered Systems Service office.

It is the responsibility of operating/service personnel as to the applicability of these documents to the equipment in question. If there is any question in the mind of operating/service personnel as to the applicability of these documents, then, prior to working on the equipment, they should verify with the owner whether the equipment has been modified and if current literature is available.

NOMENCLATURE

The model number denotes the following characteristics of the unit:

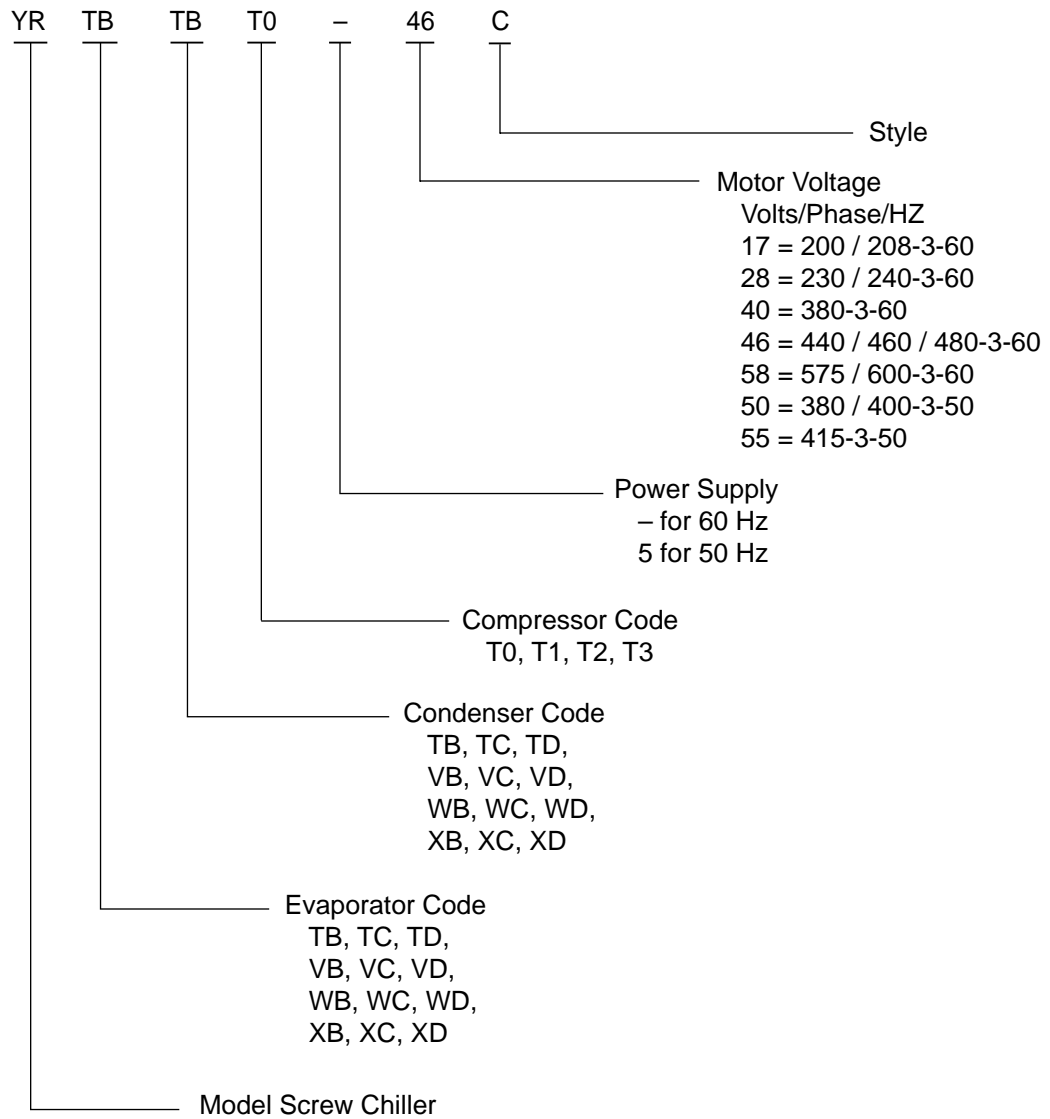

TABLE OF CONTENTS

SECTION 1 – INSTALLATION.....	8	POWER WIRING	35
GENERAL.....	8	Unit With Electro-Mechanical Starter.....	35
CONSTRUCTION DRAWINGS	8	Unit With Solid State Starter (Optional).....	36
INSPECTION – DAMAGE – SHORTAGE	9	INSULATION.....	36
DATA PLATE	9	INSTALLATION CHECK – REQUEST FOR START-UP SERVICE.....	36
LOCATION.....	10	INSTALLATION CHECK LIST AND REQUEST FOR AUTHORIZED START-UP ENGINEER FORM.....	37
FOUNDATION	10		
CLEARANCE FOR SERVICE REQUIREMENTS.....	10	SECTION 2 – CHILLER COMMISSIONING	39
RIGGING	10	OPTIVIEW CONTROL CENTER	39
OVERALL DIMENSIONS.....	13	YR CHILLERS PRE-STARTUP CHECKLIST	39
LOCATING AND INSTALLING ISOLATOR PADS	14	CONDENSER	39
CHECKING THE ISOLATOR PAD DEFLECTION	14	MOTOR	39
INSTALLING OPTIONAL SPRING ISOLATORS	16	START-UP	40
FORMS OF SHIPMENT	18	CHECKING OPERATION.....	40
GENERAL.....	18	OPERATING LOG SHEET	40
Form 2 – Factory Assembled (Standard)	18	PRE-START CHECKLIST.....	40
Form 3 – Driveline Separate From Shells	18	CHILLER COMMISSIONING	41
Form 7 – Split Shells	18	YR CHILLER START-UP	41
Form 8 – Two Major Assemblies	18	CUSTOMER (OPERATING PERSONNEL) INSTRUCTION	41
INSPECTION – DAMAGE – SHORTAGE	19		
DATA PLATE	19	SECTION 3 – OPERATION	42
RE-ASSEMBLY.....	19	BASIC DESCRIPTION.....	42
Form 3 - Shipment.....	19	COMPONENTS	42
Form 7 - Shipment.....	22	Driveline.....	42
Form 8 - Shipment.....	26	Oil Separator.....	42
OIL QUANTITIES.....	26	Condenser	42
VACUUM DEHYDRATION.....	28	Evaporator	42
OPERATION	28	Variable Orifice.....	46
SYSTEMS PRESSURES	29	OIL SYSTEM	46
PIPING CONNECTIONS	30	OIL EDUCTOR CIRCUIT	47
CHECK FOR PIPING ALIGNMENT.....	30	LIQUID REFRIGERANT CIRCUIT.....	48
EVAPORATOR AND CONDENSER WATER PIPING	30	CAPACITY CONTROL	48
Chilled Water Circuit	31	NEED FOR MAINTENANCE OR SERVICE	49
Condenser Water Circuit.....	32	NORMAL AND SAFETY SHUTDOWN AND REPAIRS ...	49
R-134a Refrigerant	32	SAFETY SHUTDOWNS	49
Stop Valves	33	CYCLING SHUTDOWNS	49
Flow Switches (Field Installed)	33	STOPPING THE SYSTEM	49
Drain and Vent Valves.....	33	PROLONGED SHUTDOWN.....	50
Checking Piping Circuits and Venting Air.....	33	START- UP AFTER PROLONGED SHUTDOWN.....	50
REFRIGERANT RELIEF PIPING	34		
UNIT PIPING	35		
CONTROL WIRING	35		

TABLE OF CONTENTS (CONT'D)

SECTION 4 – OPERATING INSPECTIONS 51	
SECTION 5 – MAINTENANCE 52	Evaporator and Condenser..... 64
GENERAL 52	Oil Return System..... 64
COMPRESSOR OIL 53	ELECTRICAL CONTROLS..... 64
Changing Compressor Oil 53	SECTION 6 – TROUBLESHOOTING 66
CHARGING UNIT WITH OIL 53	TROUBLESHOOTING GUIDE 66
OIL TEMPERATURE CONTROL 55	ABNORMAL OPERATION, ANALYSIS AND
OIL FILTER 55	CORRECTION..... 66
OIL FILTER REPLACEMENT 56	TROUBLESHOOTING THE ROTARY SCREW
Single Oil Filter 56	COMPRESSOR AND OIL SEPARATION SYSTEM 66
Dual Oil Filters (Optional) 56	PRESSURE/TEMPERATURE CONVERSION TABLES . 69
FILTER DRIER REPLACEMENT..... 56	TEMPERATURE CONVERSION TABLES 70
DETERMINING CORRECT REFRIGERANT	
CHARGE LEVEL 57	
REFRIGERANT CHARGING..... 57	
REFRIGERANT LEAK CHECKING 57	
PRESSURE CONNECTIONS..... 57	
CONDENSERS AND EVAPORATORS 58	
CLEANING EVAPORATOR AND CONDENSER	
TUBES 58	
CONDENSER WATER SIDE TUBE CLEANING	
PROCEDURE 58	
Chemical Cleaning Procedure 58	
Mechanical Cleaning Procedure..... 59	
EVAPORATOR TUBES..... 59	
MEGOHM THE MOTOR..... 60	
CHECKING SYSTEM FOR LEAKS 60	
Leak Testing During Operation 60	
Conducting R-134a Pressure Test 60	
EVACUATION AND DEHYDRATION OF UNIT 61	
CHECKING THE REFRIGERANT CHARGE	
DURING UNIT SHUTDOWN 61	
HANDLING REFRIGERANT FOR	
DISMANTLING AND REPAIRS 62	
Tube Fouling 62	
TUBE CLEANING PROCEDURES..... 62	
COMMERCIAL ACID CLEANING 62	
TESTING FOR EVAPORATOR AND CONDENSER	
TUBE LEAKS..... 62	
VIBRATION ANALYSIS..... 63	
ELECTRICAL CONTROLS..... 63	
Preventive Maintenance 63	
Compressor 63	
Pressure Testing 64	

LIST OF FIGURES

FIG. 1 – UNIT RIGGING.....	10
FIG. 2 – COMPRESSORS – EVAPORATOR, CONDENSER AND WATER BOXES DIMENSIONS.....	12
FIG. 3 – STANDARD NEOPRENE VIBRATION ISOLATOR PAD MOUNTS	14
FIG. 4 – SPRING ISOLATORS (OPTIONAL).....	16
FIG. 5 – MODEL YR – FRONT VIEW OF ASSEMBLED UNIT	18
FIG. 6 – RIGGING COMPRESSOR ASSEMBLY	19
FIG. 7 – FORM 3 FIELD ASSEMBLY – EXPLODED VIEW	21
FIG. 8 – FORM 7 SHIPMENT	22
FIG. 9 – FORM 7 FIELD ASSEMBLY – EXPLODED VIEW	25
FIG. 10 – FORM 8 FIELD ASSEMBLY – EXPLODED VIEW	27
FIG. 11 – SATURATION CURVE.....	28
FIG. 12 – SCHEMATIC OF A TYPICAL PIPING ARRANGEMENT.....	32
FIG. 12A – COOLING TOWER PIPING WITH 3 PORT BY-PASS VALVE.....	33
FIG. 13 – TYPICAL REFRIGERANT VENT PIPING FROM RELIEF VALVES.....	34
FIG. 14 – YR MOTOR CONNECTIONS.....	36
FIG. 15 – YR SCREW CHILLER COMPONENT LAYOUT DRAWING – DESIGN LEVEL “C”	43
FIG. 16 – YR SCREW CHILLER SYSTEM SCHEMATIC – DESIGN LEVEL “C”	44
FIG. 17 – OIL FILTER SYSTEM.....	46
FIG. 18 – OIL SOLENOID VALVE ASSEMBLY	48
FIG. 19 – VARIABLE ORIFICE.....	48
FIG. 20 – CHARGING OIL	54
FIG. 21 – OIL FILTERS	55
FIG. 22 – DUAL OIL FILTER ISOLATION VALVE	56
FIG. 23 – DIAGRAM, MEGOHM MOTOR WINDINGS	60

LIST OF TABLES

TABLE 1 – CONSTRUCTION DRAWINGS (PRODUCT DRAWINGS).....	9
TABLE 2 – SERVICE CLEARANCE REQUIREMENTS.....	10
TABLE 3 – UNIT WEIGHTS	11
TABLE 4 – OVERALL DIMENSIONS	13
TABLE 5 – WATER FLOW RATE LIMITS – GPM (L/S)	31
TABLE 6 – REFRIGERANT RELIEF CHARACTERISTICS	35
TABLE 7 – VARIABLE ORIFICE PRESSURE DIFFERENTIAL SETPOINTS	48
TABLE 8 – OPERATION / INSPECTION / MAINTENANCE REQUIREMENTS	52
TABLE 9 – MAINTENANCE SCHEDULE.....	52
TABLE 10 – COMPRESSOR OIL LIMITS	53
TABLE 11 – YORK OIL TYPE FOR R-134A.....	53
TABLE 12 – REFRIGERANT CHARGE LEVEL	57
TABLE 13 – OPERATING ANALYSIS CHART	67

This page intentionally left blank

SECTION 1 – INSTALLATION

GENERAL

This instruction describes the installation of a Model YR Rotary Screw Liquid Chiller. The standard unit is shipped as a single factory assembled, piped, wired and nitrogen or refrigerant charged package. This unit requires a minimum of field labor to make chilled water connections, condenser water connections, refrigerant atmospheric relief connections, and electrical power connections.

YR units can also be shipped dismantled when required by rigging conditions, but generally it is more economical to enlarge access openings to accommodate the factory assembled unit.

The services of a YORK representative will be furnished to check the installation and perform the initial start-up of all units in accordance with the contract.

CONSTRUCTION DRAWINGS

Construction drawings are furnished for each job as noted in Table 1. These drawings must be carefully followed and used in conjunction with this installation instruction, to ensure proper installation of the unit.

In event of any differences between drawings and this instruction, the drawings shall supercede this instruction.

TABLE 1 – CONSTRUCTION DRAWINGS (PRODUCT DRAWINGS) ISSUED BY THE YORK DISTRICT OFFICE

DESCRIPTION	371-02772 CONTROL CENTER NO.
	PRODUCT DRAWING FORM NO.
Dimensions and Physical Data	160.81-PA1
Wiring Diagram MicroComputer Control Center Solid State Starter	160.81-PW2
Wiring Diagram MicroComputer Control Center Electro-Mechanical Starter	160.81-PW1
Field Wiring, Solid State Starter	160.81-PW4
Field Wiring, Electro-Mechanical Starter	160.81-PW3
Field Control Modifications	160.81-PW5
Remote Motor Starter Specifications with OptiView Control Center	160.81-PW7



The YORK Warranty will be voided if the following restrictions are not adhered to:

- 1. No valves or connections should be opened under any circumstances because such action will result in loss of the factory refrigerant or nitrogen charge.*
- 2. Do not dismantle or open the unit for any reason except under the supervision of a YORK representative.*
- 3. When units are shipped dismantled, notify the nearest YORK office in ample time for a YORK representative to supervise rigging the unit to its operating position and the assembly of components.*
- 4. Do not make final power supply connections to the compressor motor or control center.*
- 5. Do not charge the system with oil.*
- 6. Do not attempt to start the system.*
- 7. When chiller is charged, do not run hot water (100°F, 38°C max.) or steam through the evaporator.*

INSPECTION – DAMAGE – SHORTAGE

The unit shipment should be checked on arrival to see that all major pieces, boxes and crates are received. Each unit should be checked on the trailer when received, before unloading, for any visible signs of damage. Any damage or signs of possible damage must be reported to the transportation company immediately for their inspection.



YORK WILL NOT BE RESPONSIBLE FOR ANY DAMAGE IN SHIPMENT OR AT JOB SITE OR LOSS OF PARTS.

When received at the job site all containers should be opened and contents checked against the packing list. Any material shortage should be reported to YORK immediately. (Refer to Shipping Damage Claims, Form 50.15-NM.)

DATA PLATE

A unit data plate is mounted on the control center assembly of each unit, giving unit model number; design working pressure; water passes; refrigerant charge; serial numbers; and motor power characteristics and connection diagrams. Refer to “Nomenclature” on page 3 to verify data plate markings.

LOCATION

The chiller should be located in an indoor location where temperature ranges from 40°F to 110°F (4°C to 43°C).

The units are furnished with neoprene vibration isolator mounts for basement or ground level installations. Units may be located on upper floor levels provided the floor is capable of supporting the total unit operating weight. Refer to Figure 2 and Table 3.

Equipment room should be ventilated to allow adequate heat removal. Check ANSI, state, local or other codes.

FOUNDATION

A level floor, mounting pad or foundation must be provided by others, capable of supporting the operating weight of the unit.

CLEARANCE FOR SERVICE REQUIREMENTS

Clearances should be adhered to as follows:

- Rear, Ends and Above Unit – 2 Feet / 610 mm
- Front of Unit – 3 Feet / 914 mm
- Tube Removal – See Table 2

TABLE 2 – SERVICE CLEARANCE REQUIREMENTS

SHELL CODES	TUBE REMOVAL SPACE		ADD – MARINE WATER BOXES	
	Ft. - In.	mm	Ft. - In.	mm
TB, TC, TD	10'-1"	3073	2'-2"	660
VB, VC, VD	14'-1"	4293	2'-2"	660
WB, WC, WD	12'-1"	3683	2'-2"	660
XB, XC, XD	16'-1"	4902	2'-2"	660

RIGGING

The complete standard unit is shipped without skids. (When optional skids are used, it may be necessary to remove the skids so riggers skates can be used under the unit end sheets to reduce the overall height.)

Each unit has four lifting holes (two on each end) in the end sheets which should be used to lift the unit. Care should be taken at all times during rigging and handling to avoid damage to the unit and its external connections. Lift only using holes shown in Figure 1.



Do not lift the unit with slings around motor/compressor assembly or by means of eyebolts in the tapped holes of the compressor motor assembly. Do not turn a unit on its side for rigging. Do not rig with driveline in a vertical orientation.



If necessary to rig a unit by one end to permit lifting or dropping through a vertical passageway, such as an elevator shaft, contact YORK Factory for special rigging instructions.

The shipping and operating weights are given in Table 3. Overall dimensions are shown in Fig. 2. More detailed dimensions can be found in Form 160.81-PA1.

If optional shipping skids are used, remove them before lowering the unit to its mounting position. Rig the unit to its final location on the floor or mounting pad by lifting the unit (or shell assembly) with an overhead lift and lower the unit to its mounting position.

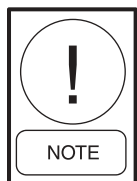

Units shipped dismantled should be assembled under the supervision of a YORK representative.

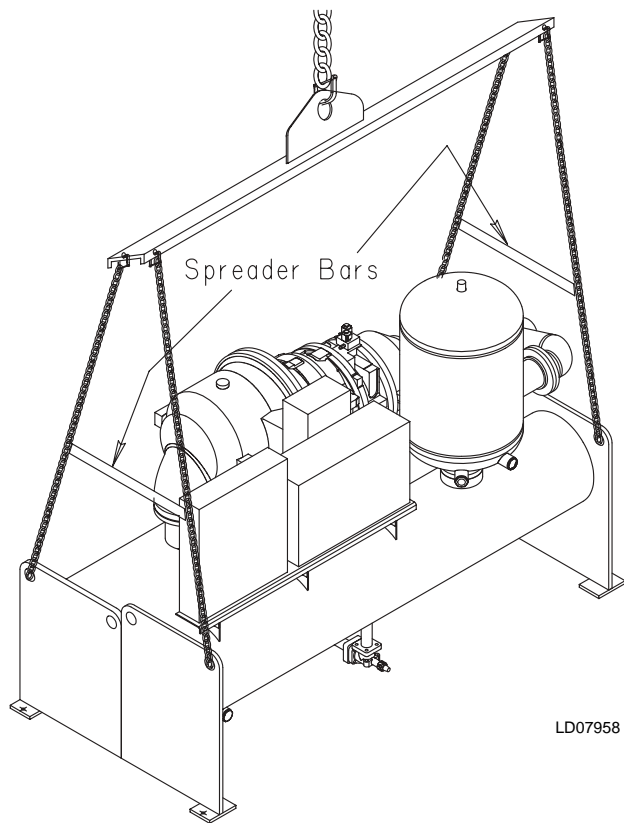
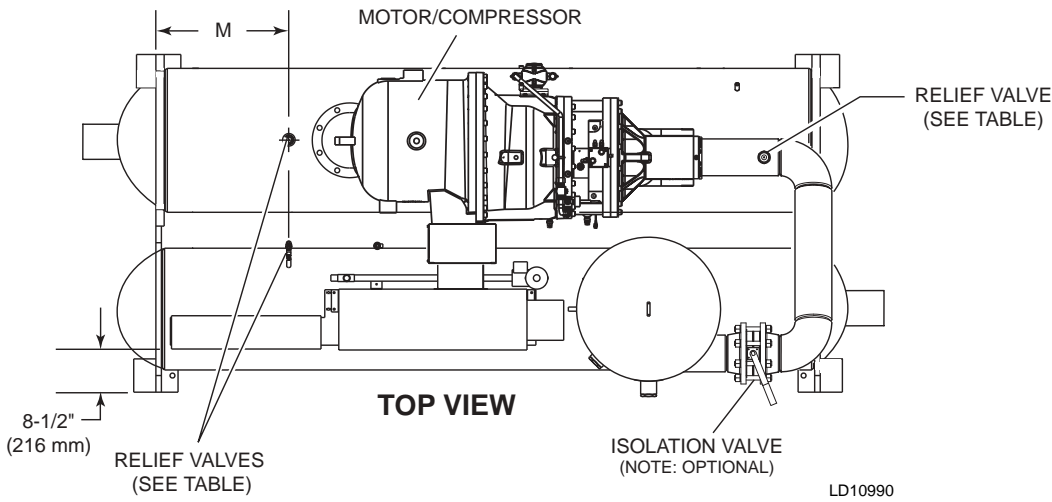

FIG. 1 – UNIT RIGGING

TABLE 3 – UNIT WEIGHTS

COMP.	SHELLS	SHIPPING WEIGHT		OPERATING WEIGHT		REFRIGERANT CHARGE		LOADING PER ISOLATOR	
		(LBS)	(KG)	(LBS)	(KG)	(LBS)	(KG)	(LBS)	(KG)
T0/T1	TBTB	11,860	5,380	13,110	5,948	650	295	3,278	1,485
	TBTC	11,910	5,400	13,200	5,988	650	295	3,303	1,495
	TBTD	12,010	5,450	13,350	6,053	650	295	3,338	1,515
	TCTB	11,960	5,425	13,250	6,013	650	295	3,313	1,500
	TCTC	12,010	5,450	13,340	6,053	650	295	3,338	1,515
	TCTD	12,110	5,495	13,490	6,123	650	295	3,373	1,530
	TDTB	12,070	5,475	13,410	6,083	650	295	3,353	1,520
	TDTC	12,120	5,500	13,500	6,123	650	295	3,378	1,530
	TDTD	12,220	5,540	13,650	6,193	650	295	3,413	1,545
	VBVB	12,680	5,750	14,320	6,495	900	408	3,580	1,625
	VBVC	12,750	5,785	14,450	6,555	900	408	3,615	1,640
	VBVD	12,890	5,845	14,660	6,649	900	408	3,665	1,665
	VCVB	12,820	5,815	14,520	6,586	900	408	3,630	1,645
	VCVC	12,900	5,850	14,650	6,645	900	408	3,665	1,665
	VCVD	13,030	5,910	14,850	6,735	900	408	3,715	1,685
	VDVB	12,990	5,890	14,750	6,690	900	408	3,690	1,675
VDVC	13,070	5,930	14,890	6,755	900	408	3,725	1,690	
VDVD	13,200	5,990	15,090	6,845	900	408	3,775	1,710	
T1	WBWB	14,660	6,650	17,160	7,784	1,250	567	4,290	1,946
	WBWC	14,930	6,772	17,550	7,961	1,250	567	4,388	1,990
	WBWD	15,520	7,040	18,020	8,174	1,250	567	4,505	2,043
	WCWB	14,840	6,731	17,410	7,897	1,250	567	4,353	1,975
	WCWC	15,110	6,854	17,800	8,074	1,250	567	4,450	2,019
	WCWD	15,440	7,004	18,280	8,292	1,250	567	4,570	2,073
	WDWB	15,070	6,836	17,730	8,042	1,250	567	4,433	2,011
	WDWC	15,340	6,958	18,120	8,219	1,250	567	4,530	2,055
WDWD	15,670	7,108	18,600	8,437	1,250	567	4,650	2,109	
T2/T3	WBWB	17,810	8,079	20,310	9,213	1,250	567	5,078	2,303
	WBWC	18,070	8,197	20,690	9,384	1,250	567	5,172	2,346
	WBWD	18,400	8,346	21,170	9,603	1,250	567	5,293	2,400
	WCWB	17,990	8,160	20,560	9,326	1,250	567	5,140	2,331
	WCWC	18,260	8,283	20,950	9,503	1,250	567	5,238	2,375
	WCWD	18,580	8,428	21,420	9,716	1,250	567	5,355	2,429
	WDWB	18,220	8,265	20,880	9,471	1,250	567	5,220	2,367
	WDWC	18,490	8,387	21,270	9,648	1,250	567	5,318	2,412
	WDWD	18,810	8,532	21,740	9,861	1,250	567	5,435	2,465
	XBXB	19,110	8,669	22,200	10,070	1,550	703	5,550	2,518
	XBXC	19,370	8,786	22,620	10,260	1,550	703	5,655	2,565
	XBXD	19,700	8,935	23,150	10,500	1,550	703	5,788	2,625
	XCXB	19,360	8,782	22,540	10,224	1,550	703	5,635	2,556
	XCXC	19,620	8,900	22,960	10,415	1,550	703	5,740	2,603
	XCXD	19,950	9,049	23,490	10,655	1,550	703	5,873	2,664
	XDXB	19,670	8,922	22,970	10,419	1,550	703	5,743	2,605
XDXC	19,940	9,045	23,400	10,614	1,550	703	5,850	2,654	
XDxD	20,260	9,190	23,920	18,850	1,550	703	5,980	2,713	



RELIEF VALVES*		
LOCATION	WITH ISOLATION VALVES	WITHOUT ISOLATION VALVES
EVAPORATOR	1" SINGLE	1" DUAL
CONDENSER	1" DUAL	1" SINGLE
DISCHARGE LINE	1-1/4" SINGLE	NONE

*All are NPT female

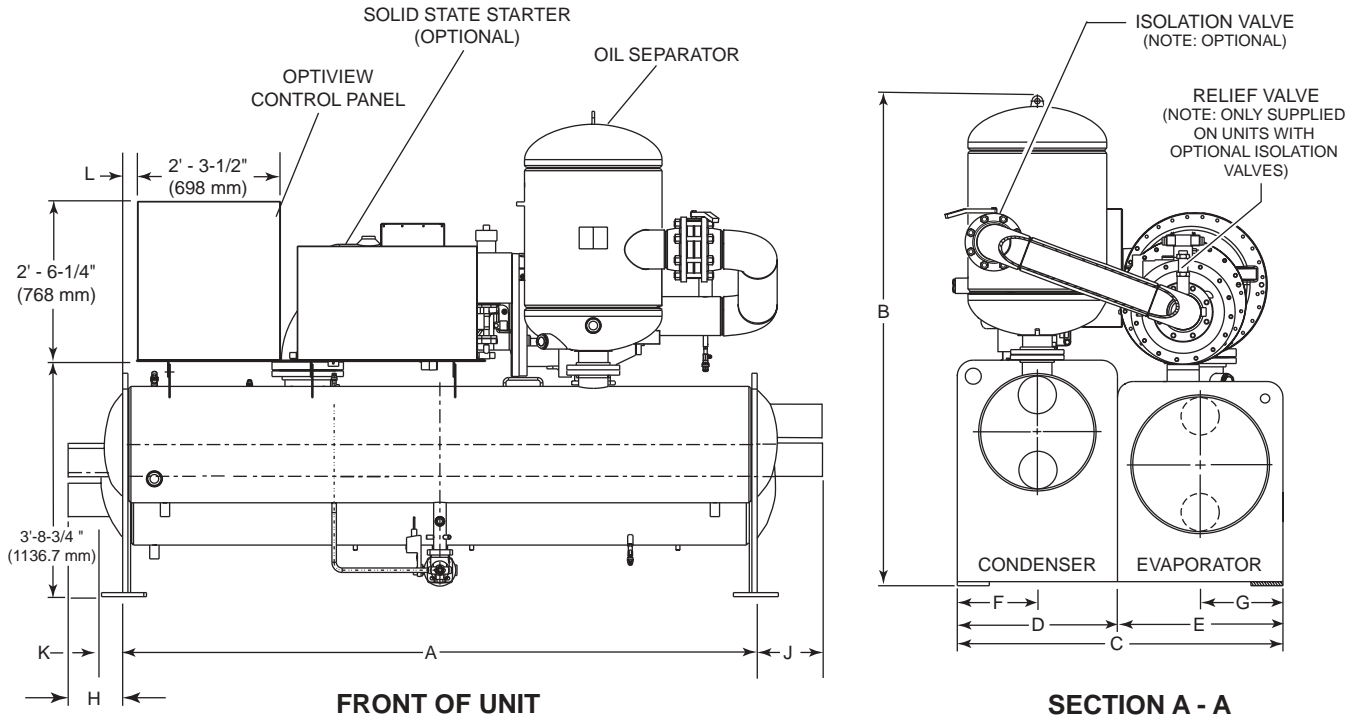

LD11006

FIG. 2 – COMPRESSORS – EVAPORATOR, CONDENSER AND WATER BOXES DIMENSIONS

OVERALL DIMENSIONS

1

TABLE 4 – OVERALL DIMENSIONS

DIM.	EVAPORATOR – CONDENSER SHELL CODES									
	T0 & T1 COMPRESSORS				T1 COMPRESSORS		T2 & T3 COMPRESSORS			
	T - T	V - V	T - T	V - V	W - W	W - W	W - W	X - X	W - W	X - X
A	10'-0"	14'-0"	3048 mm	4267 mm	12'-0"	3657 mm	12'-0"	16'-0"	3658 mm	4877 mm
B	7'-5-1/8"	7'-5-1/8"	2264 mm	2264 mm	7'-9-3/4"	2381 mm	8'-10-7/8"	8'-10-7/8"	2715 mm	2715 mm
C	5'-1"	5'-1"	1550 mm	1550 mm	5'-6"	1676 mm	5'-6"	5'-6"	1676 mm	1676 mm
D	2'-6"	2'-6"	762 mm	762 mm	2'-7"	787 mm	2'-7"	2'-7"	787 mm	787 mm
E	2'-7"	2'-7"	787 mm	787 mm	2'-11"	889 mm	2'-11"	2'-11"	889 mm	889 mm
F	1'-3"	1'-3"	381 mm	381 mm	1'-3-1/2"	114 mm	1'-3-1/2"	1'-3-1/2"	394 mm	394 mm
G	1'-3-1/2"	1'-3-1/2"	394 mm	394 mm	1'-5-1/2"	165 mm	1'-5-1/2"	1'-5-1/2"	445 mm	445 mm
L	2'-3/4"	2'-2-3/4"	70 mm	679 mm	2'-3/4"	70 mm	2'-3/4"	2'-2-3/4"	70 mm	679 mm
M	1'-3"	3'-3"	381 mm	991 mm	1'-3"	381 mm	1'-3"	3'-3"	381 mm	991 mm

WATER BOX DIMENSIONS (FT. - IN)						
DIM.	EVAPORATORS T & V			CONDENSER T & V		
	1 PASS	2 PASS	3 PASS	1 PASS	2 PASS	3 PASS
H	1'-2-3/4"	1'-1-1/2"	1'-1-1/2"	—	—	—
J	—	—	—	1'-2-3/4"	1'-0-1/2"	1'-0-1/2"
DIM.	REAR HEAD 2 PASS			REAR HEAD 2 PASS		
K	8-3/4"			7-5/8"		

WATER BOX DIMENSIONS (mm)						
DIM.	EVAPORATORS T & V			CONDENSER T & V		
	1 PASS	2 PASS	3 PASS	1 PASS	2 PASS	3 PASS
H	375	343	343	—	—	—
J	—	—	—	375	318	318
DIM.	REAR HEAD 2 PASS			REAR HEAD 2 PASS		
K	222			194		

WATER BOX DIMENSIONS (FT. - IN)						
DIM.	EVAPORATORS W & X			CONDENSER W & X		
	1 PASS	2 PASS	3 PASS	1 PASS	2 PASS	3 PASS
H	1'-2-1/4"	1'-2-1/4"	1'-2-1/4"	—	—	—
J	—	—	—	1'-2-1/4"	1'-2-1/4"	1'-2-1/4"
DIM.	REAR HEAD 2 PASS			REAR HEAD 2 PASS		
K	5-5/8"			5-5/8"		

WATER BOX DIMENSIONS (mm)						
DIM.	EVAPORATORS W & X			CONDENSER W & X		
	1 PASS	2 PASS	3 PASS	1 PASS	2 PASS	3 PASS
H	362	362	362	—	—	—
J	—	—	—	362	362	362
DIM.	REAR HEAD 2 PASS			REAR HEAD 2 PASS		
K	143			143		

LOCATING AND INSTALLING ISOLATOR PADS

The isolator pads should be located in accordance with the floor layout of the dimensional product drawing, Form 160.81-PA1. After the isolator pads have been placed into position on the floor, lower the unit onto the pads. Make sure the pads are even with the edges of the mounting feet. When the unit is in place, remove the rigging equipment and check that the chiller is level, both longitudinally and transversely. See Figure 3.

The longitudinal alignment of the unit should be checked by placing a level on the top center of the evaporator shell **under the compressor/motor assembly**. Transverse alignment should be checked by placing a level on top of the shell end sheets at each end of the unit.

The unit should be level within 1/4 inch (6 mm) from one end to the other end and from front to the rear. If the chiller is not level within the amount specified, lift it and place shims between the isolation pad and the tube sheets.

CHECKING THE ISOLATOR PAD DEFLECTION

All isolator pads should be checked for the proper deflection while checking the level of the unit. Each pad should be deflected approximately 0.15 inch (4 mm). If an isolator pad is under deflected, shims should be placed between the unit tube sheet and the top of the pad to equally deflect all pads. Refer to Figure 3.

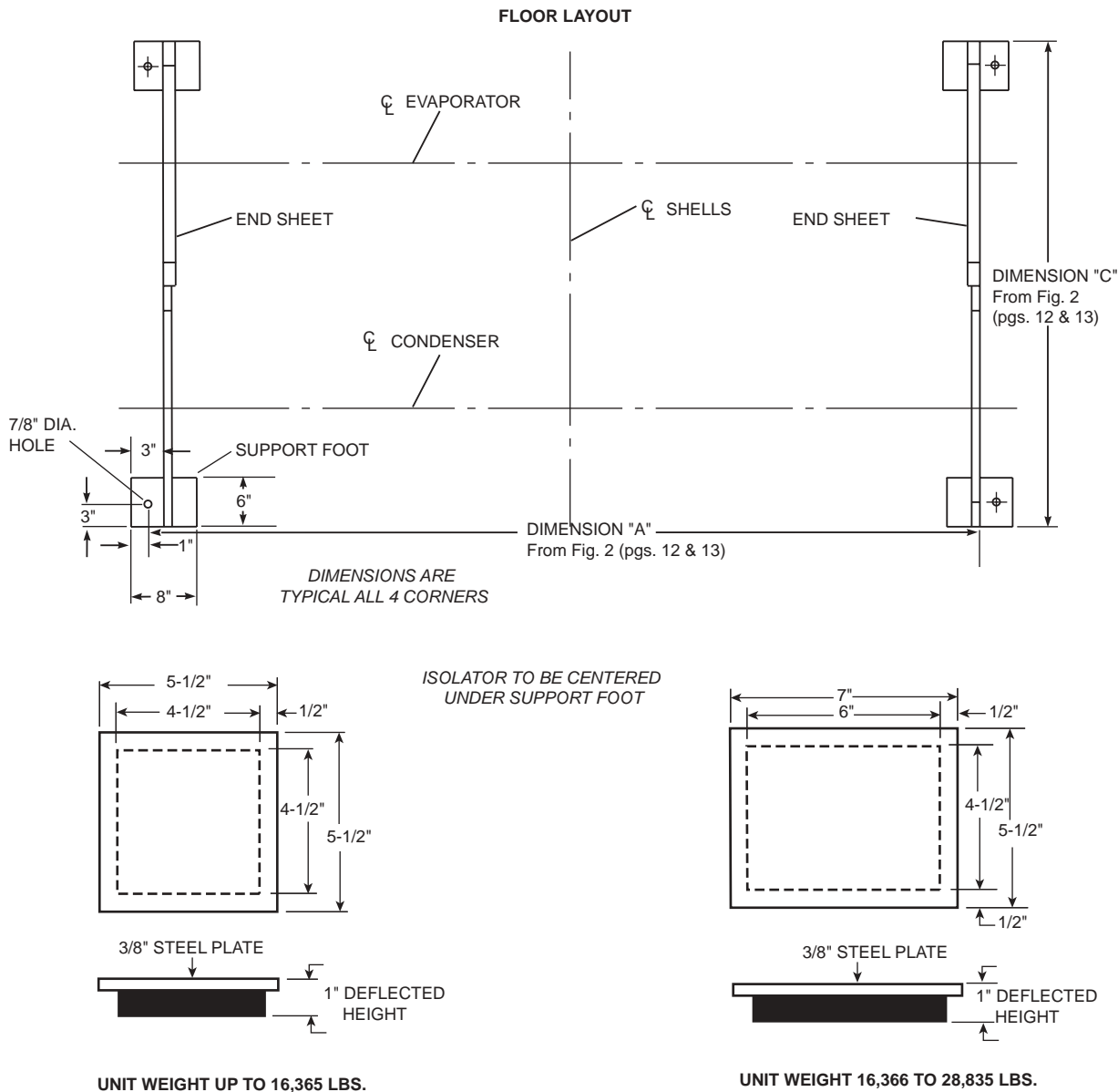
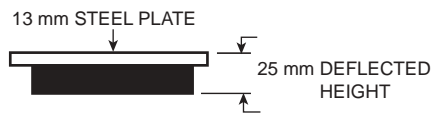
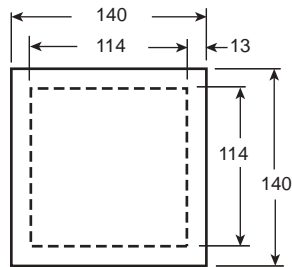
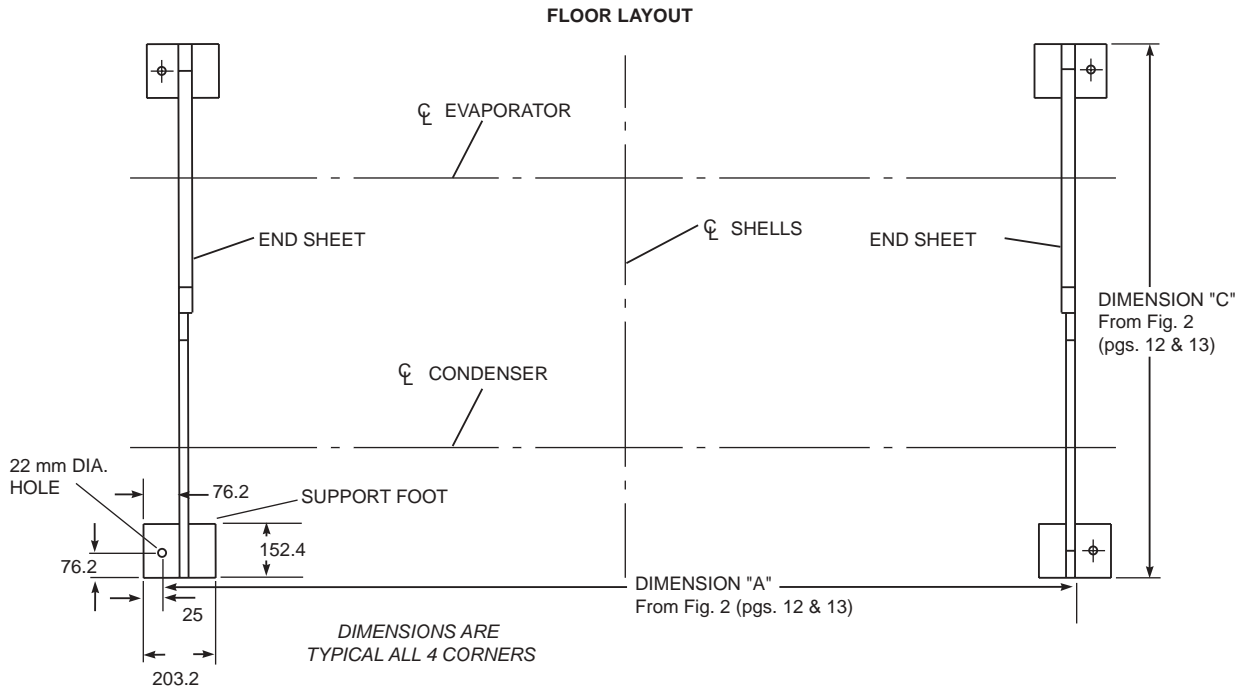

FIG. 3 – STANDARD NEOPRENE VIBRATION ISOLATOR PAD MOUNTS

LD07959



UNIT WEIGHT UP TO 7,423 KGS.

ISOLATOR TO BE CENTERED
UNDER SUPPORT FOOT

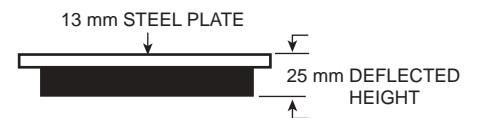
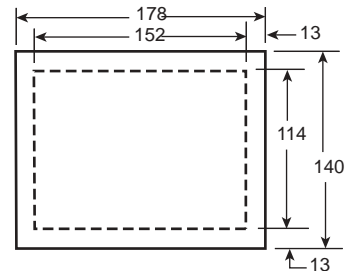

UNIT WEIGHT 7,423 TO 13,107 KGS.

FIG. 3 – STANDARD NEOPRENE VIBRATION ISOLATOR PAD MOUNTS (CONT'D)

LD07960

**INSTALLING OPTIONAL SPRING ISOLATORS
(REFER TO FIG. 4)**

When ordered, 4 spring type isolator assemblies will be furnished with the unit. The 4 assemblies are identical and can be placed at any of the 4 corners of the unit.

While the unit is still suspended by the rigging, the isolators should be bolted to the unit by inserting the cap screw(s) through the hole(s) in the mounting bracket into the tapped hole in the top of the isolator leveling bolt(s). Then the unit can be lowered onto the floor.

The leveling bolts should now be rotated one (1) turn at a time, in sequence, until the unit end sheets are clear of the floor by the dimension shown in Fig. 4 and the unit is level. Check that the unit is level, both longitudinally

and transversely (see Leveling the Unit). If the leveling bolts are not long enough to level unit due to an uneven or sloping floor or foundation, steel shims (grouted, if necessary) must be added beneath the isolator assemblies as necessary.

After the unit is leveled, wedge and shim under each corner to solidly support the unit in this position while piping connections are being made, pipe hangers adjusted and connections checked for alignment. Then the unit is filled with water and checked for leaks. The leveling bolts should now be finally adjusted until the wedges and shims can be removed. The unit should now be in correct level position, clear of the floor or foundation and without any effect from the weight of the piping.

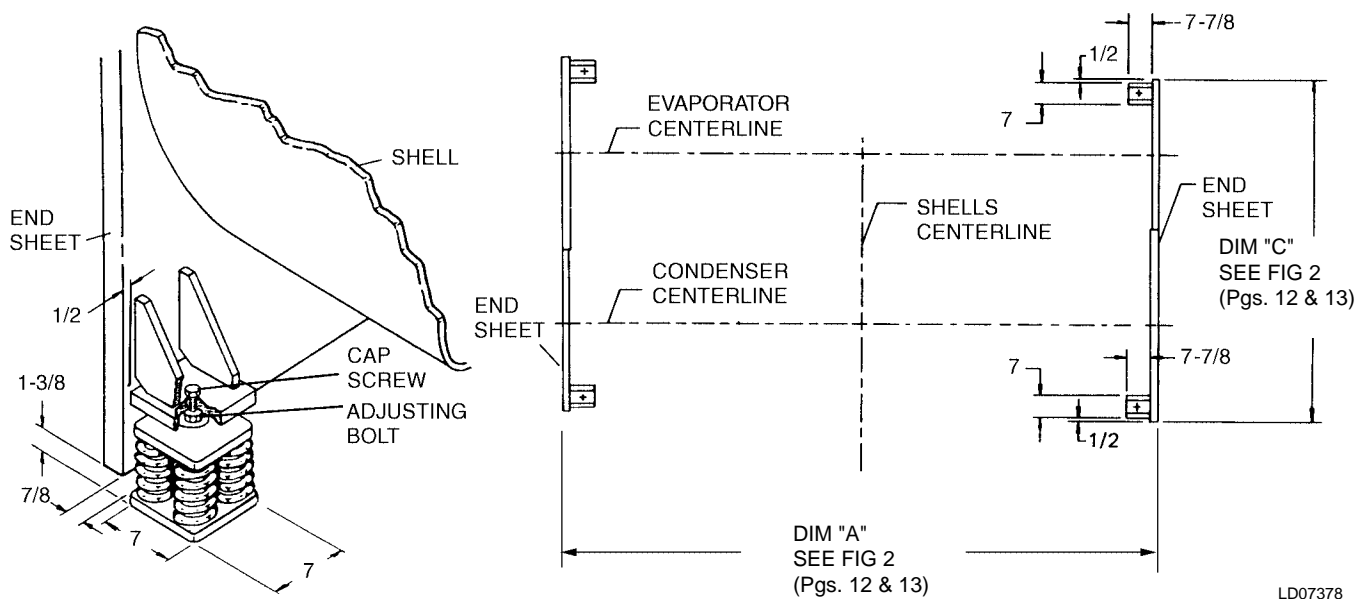

ALL DIMENSIONS ARE IN INCHES

FIG. 4 – SPRING ISOLATORS (OPTIONAL)

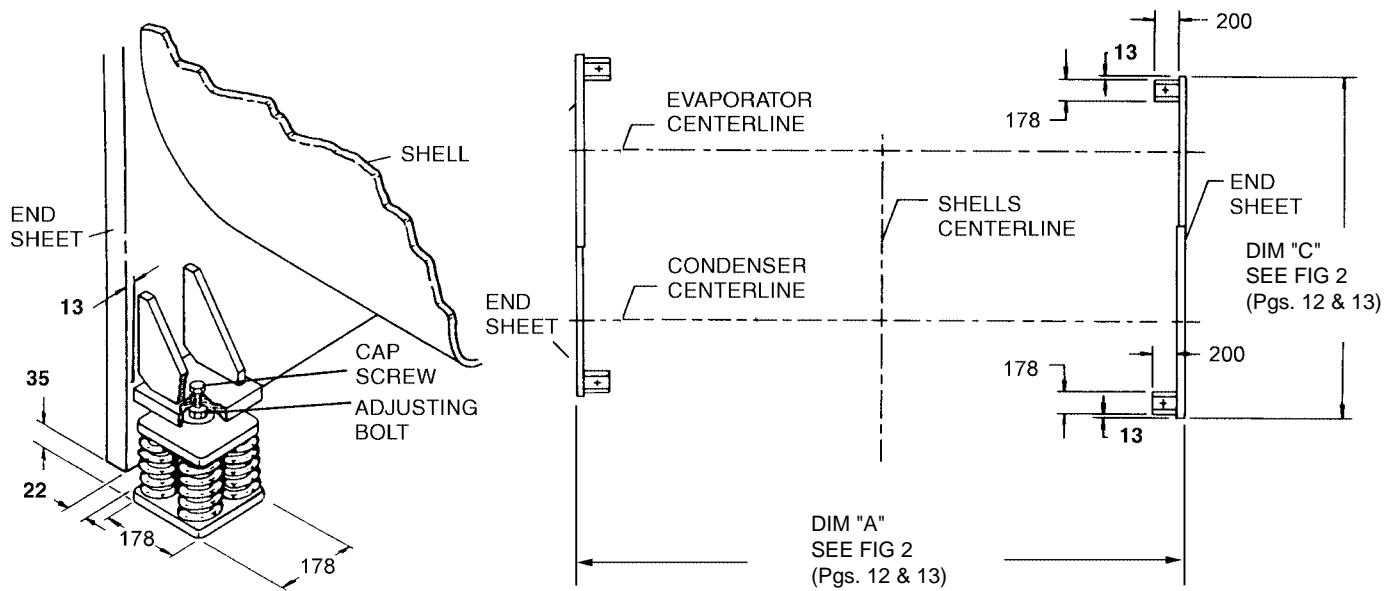

ALL DIMENSIONS ARE IN MILLIMETERS

LD07379

FIG. 4 – SPRING ISOLATORS (OPTIONAL) (CONT'D)

SHIPPING FORM 2, 3, 7, AND 8

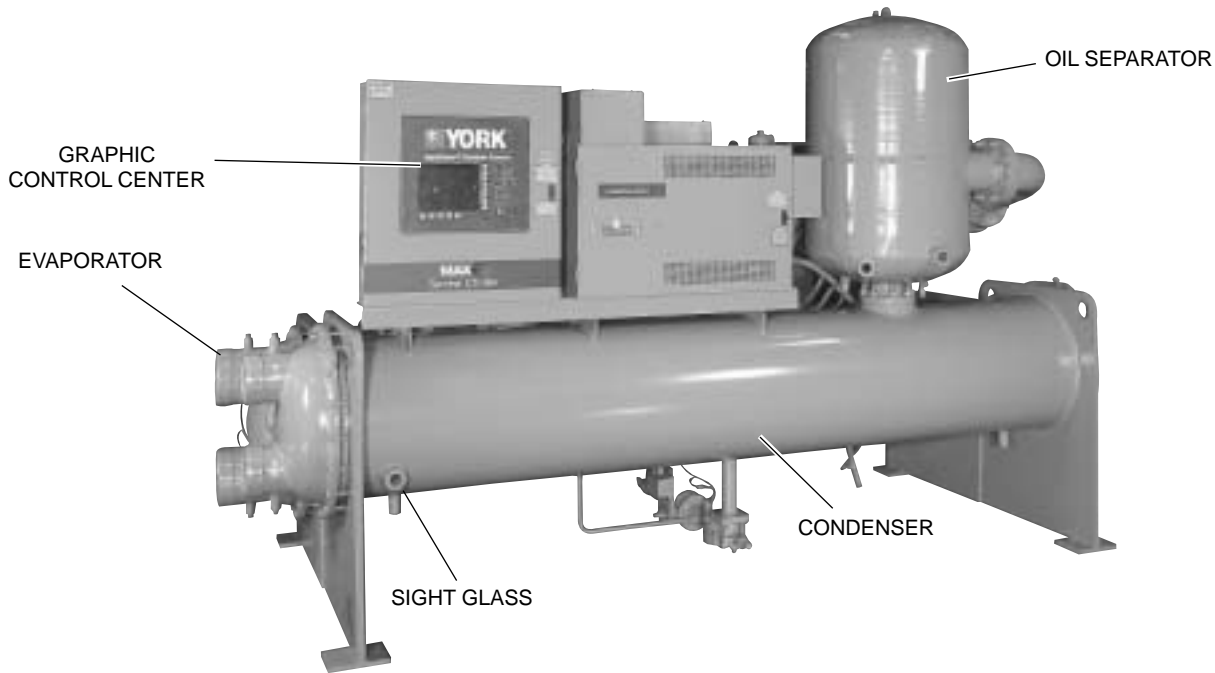

00562VIP

FIG. 5 – MODEL YR – FRONT VIEW OF ASSEMBLED UNIT

GENERAL

This instruction explains the procedure to be used for re-assembling the Model YR Rotary Screw Chiller shipped disassembled. (Shipping Form 3, 7, and 8.)



Units *MUST* be field reassembled under the supervision of a YORK service representative.

FORMS OF SHIPMENT

FORM 2 – FACTORY ASSEMBLED (STANDARD)

– Unit completely assembled except not charged with oil or refrigerant. Standard oil shipped separately. Refrigerant shipped separately in 50 & 125 lb (23 & 57 kg) cylinders. Shipped with holding charge of nitrogen.

FORM 3 – DRIVELINE SEPARATE FROM SHELLS

– Shipped as three major assemblies. The unit is first factory assembled, refrigerant piped, wired and leak tested, then dismantled for shipment. Compressor/open motor assembly is removed from shells and skidded. Evaporator/condenser assembly is not skidded. Oil separator is skidded.

All wiring integral with the compressor is shipped on the compressor, and all conduit is shipped on the heat

exchanger. All openings on the compressor, oil separator, and the shell are closed and charged with dry nitrogen [5 psig (34 kPa)].

Miscellaneous chiller components, [control center, oil eductor filter, tubing, water temperature controls, wiring, oil, vibration isolators, solid state starter (option), etc.] are packaged separately and shipped with the chiller. R-134a charge is shipped concurrently or separately in 50 lb. and 125 lb (23 & 57 kg) cylinders.

FORM 7 – SPLIT SHELLS

– The unit is shipped as four major assemblies (evaporator, condenser, motor/compressor assembly and oil separator). The unit is first factory assembled, refrigerant piped, wired and leak tested, then dismantled for shipment. Compressor/open motor assembly is removed from shells and skidded. Oil separator is skidded.

Evaporator and condenser shells are separated at tube sheets and are not skidded. Refrigerant lines between shells are flanged and capped. Tube sheets will require bolting in the field. No welding is required.

All wiring integral with compressor is shipped on it. All wiring harnesses on shells are removed.

All openings on compressor, oil separator and shells are closed and charged with dry nitrogen [5 psig (34 kPa)].

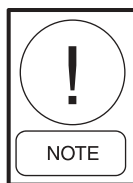

When more than one unit is involved, the major parts of each unit will be marked to prevent mixing of assemblies. (Piping and Wiring Drawings to be furnished by YORK.)

Miscellaneous packaging of control center, oil eductor filter, tubing, wiring, oil, isolators, solid state starter (option), and other miscellaneous items are shipped concurrently in a separate box. R-134a charge is shipped concurrently or separately in 50 lb. and 125 lb (23 & 57 kg) cylinders.

FORM 8 – Shipped as two major assemblies. Unit first factory assembled, refrigerant piped, wired and leak tested; then dismantled for shipment. Oil separator and discharge line is skidded.

All wiring integral with hermetic compressor is left on it, and all conduit is left on the shell. All openings on compressor, oil separator and shells are closed and charged with dry nitrogen (2 to 3 PSIG).

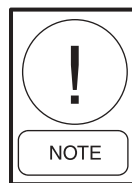

Units shipped dismantled MUST be reassembled by, or under the supervision of a YORK Representative.

INSPECTION – DAMAGE – SHORTAGE

The unit shipment should be checked on arrival to see that all major pieces, boxes and crates are received. Each unit should be checked on the trailer or rail car when received, before unloading, for any visible signs of damage. Any damage or signs of possible damage must be reported to the transportation company immediately for their inspection.

When received at the job site, all containers should be opened and contents checked against the packing list. Any material shortage should be reported to YORK immediately.

YORK WILL NOT BE RESPONSIBLE FOR ANY DAMAGE IN SHIPMENT OR AT JOB SITE OR LOSS OF PARTS. (Refer to Shipping Damage Claims, Form 50.15-NM.)

DATA PLATE

A unit data plate is mounted on the control center assembly of each unit, giving unit model number, design working pressure, water passes, refrigerant charge, serial numbers, and motor power characteristics and connection diagrams.

RE-ASSEMBLY

The following are step-by-step procedures to be used to assemble the units. Refer to other sections in this manual for further instruction.

Form 3 Shipment

1. Assemble vibration isolators to the unit. (Refer to the *Isolator Pads* Section of this manual)
2. Level shells in both directions. The longitudinal alignment of the shell should be checked by placing a level on the top of the shell, next to the discharge connection. The transverse alignment should be checked by placing a level on the tops of both end sheets. After shell is leveled, wedge and shim each corner of the shell to solidly support it while assembling the other parts.
3. Lift compressor-motor assembly and remove packing materials and shipping skids. Keep the compressor unit supported by the hoist until all connections are finally made to the shell assembly. (Refer to Figure 6 for rigging method.) Remove closure covers and be sure flanges are clean.

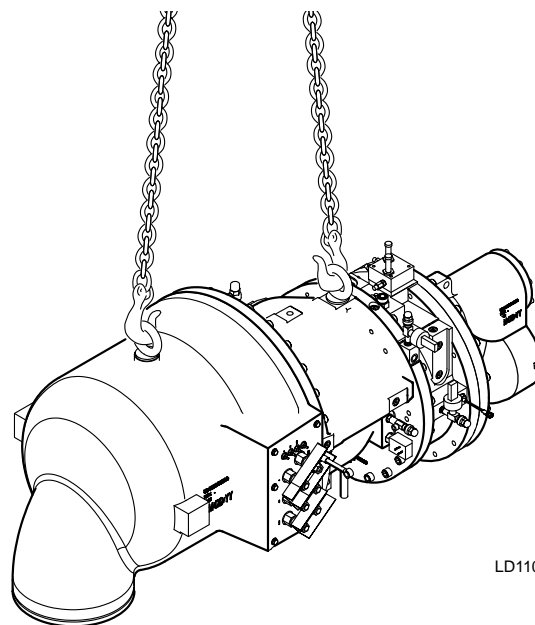

LD11007

FIG. 6 – RIGGING COMPRESSOR ASSEMBLY

Evaporator-Condenser Shells – Remove all refrigerant connection covers.



Shells are shipped with a 5 psig (34 kPa) nitrogen charge.

4. Place gasket on the evaporator suction flange and lower the compressor assembly. Guide the studs through the gasket and suction flange on top of evaporator. (Refer to Figure 7.)
5. Insert the cap screws, washers, and nuts to fasten the motor to the motor support bracket. Level the compressor-motor. If necessary, adjust the screws and nuts to level compressor, and add shims if necessary, between the motor feet and the support. (Refer to Figure 7.)
6. Assemble nuts to studs on the evaporator suction flange. Tighten nuts alternately and evenly, to insure a leak tight fit.
7. Remove the hoist from the compressor-motor assembly.
8. Place gasket on the condenser discharge connection and then place the condenser shut-off valve on the discharge connection. Make sure the handle of the shut-off valve is perpendicular to the condenser shell. Place gasket on the top side of the shut-off valve.
9. Remove all cover closures from the oil separator flanges and wipe all connection surfaces clean. Lower the oil separator carefully keeping it level and horizontal to the condenser shell. Line up the compressor discharge port with the oil separator connection. Push the oil separator connection until it seats itself. Use cap screws and washers to fasten the oil separator connection to the compressor. Complete the connection to the condenser shell using cap screws and nuts. Keep hoist rigging attached to the oil separator.
10. Fasten the support bracket between the condenser and the end of the oil separator with the proper hardware.
11. Tighten all screws and nuts on the discharge flange and the support bracket.

FORM 3 FIELD ASSEMBLY PARTS:

ITEM NO.	DESCRIPTION
1	COMPRESSOR WITH MOTOR
2	GASKET
3	DISCHARGE LINE
4	SCREW
5	NUT
6	LOCKWASHER
7	VALVE, BUTTERFLY
8	SCREW
9	SCREW
10	OIL SEPARATOR
13	STUD
14	SEAL, O-RING
15	HOT GAS BYPASS
16	CONDENSER
23	EVAPORATOR
24	GASKET
25	ISOLATOR KIT
26	WASHER
27	STRAINER
28	SHIMS
29	STUD

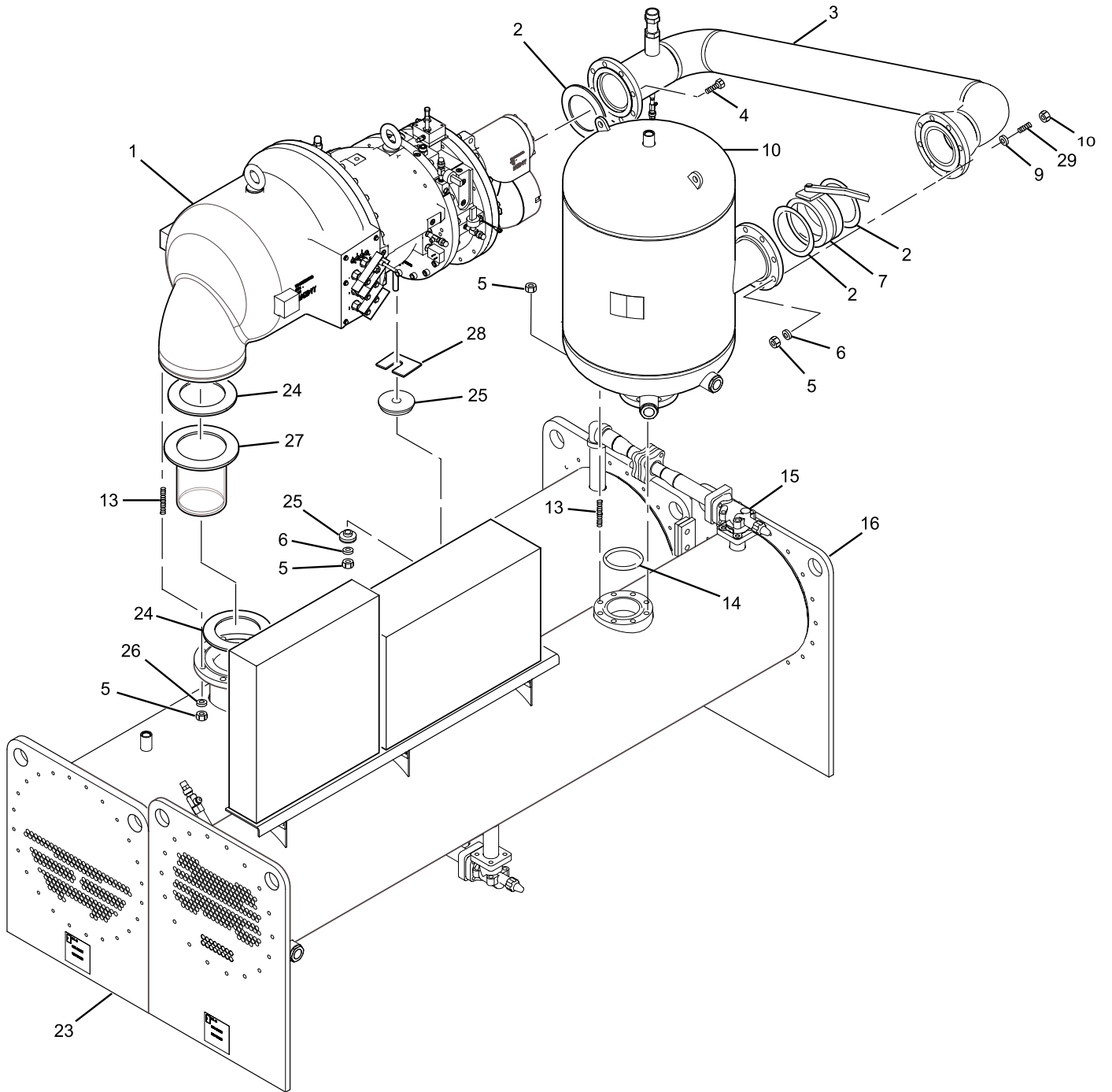

FIG. 7 – FORM 3 FIELD ASSEMBLY – EXPLODED VIEW

YORK INTERNATIONAL

Form 7 Shipment

1. Locate evaporator and condenser shells in their final position.
2. Remove shipping closures from the flanges on refrigerant line on bottom of evaporator and condenser. (Shells are shipped with a holding charge of nitrogen.) Discard gaskets. Install orifice plate using new gaskets and 3/4" x 3" long cap screws and nuts.
3. Bolt tube sheets together using cap screws, lock washers and nuts. (Refer to Figure 8)
4. Assemble vibration isolators to the unit. (Refer to the *Isolator Pads* Section of this manual)
5. Level shells in both directions. The longitudinal alignment of the shell should be checked by placing a level on the top of the shell, next to the discharge connection. The transverse alignment should be checked by placing a level on the tops of both end sheets. After shell is leveled, wedge and shim each corner of the shell to solidly support it while assembling the other parts.

6. Lift compressor-motor assembly and remove packing materials and shipping skids. Keep the compressor unit supported by the hoist until all connections are finally made to the shell assembly. (Refer to Figure 6 for rigging method.) Remove closure covers and be sure flanges are clean.

Evaporator-Condenser Shells – Remove all refrigerant connection covers.



Shells are shipped with a 5 psig (34 kPa) nitrogen charge.

7. Place gasket on the evaporator suction flange and lower the compressor assembly. Guide the studs through the gasket and suction flange on top of evaporator. (Refer to Figure 9.)

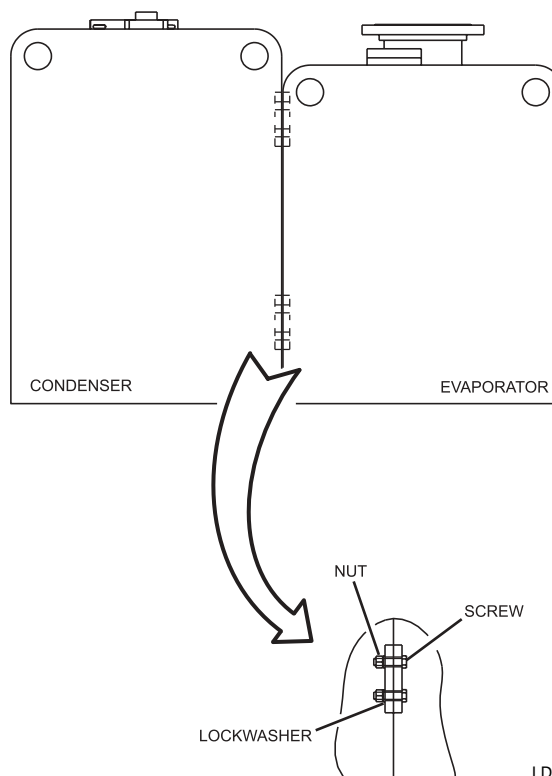
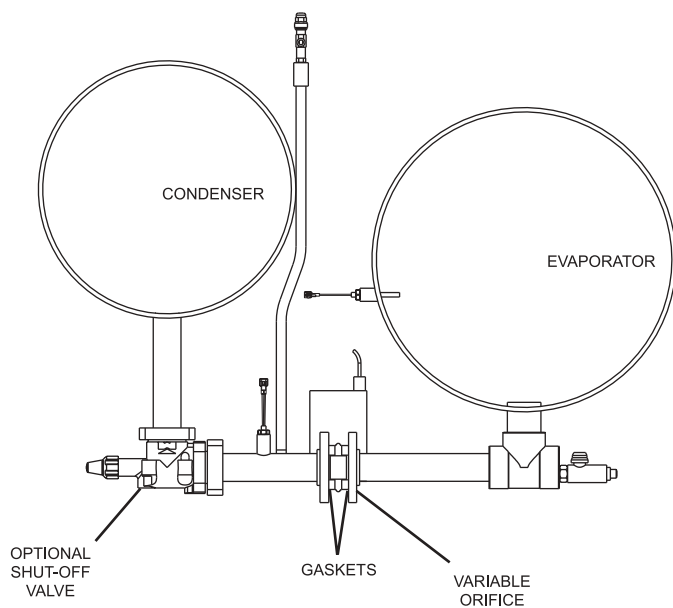

LD09035

FIG. 8 – FORM 7 SHIPMENT

8. Insert the cap screws, washers, and nuts to fasten the motor to the motor support bracket. Level the compressor-motor. If necessary, adjust the screws and nuts to level compressor, and add shims if necessary, between the motor feet and the support. (Refer to Figure 9.)
9. Assemble nuts to studs on the evaporator suction flange. Tighten nuts alternately and evenly, to insure a leak tight fit.
10. Remove the hoist from the compressor-motor assembly.
11. Place gasket on the condenser discharge connection and then place the condenser shut-off valve on the discharge connection. Make sure the handle of the shut-off valve is perpendicular to the condenser shell. Place gasket on the top side of the shut-off valve.
12. Remove all cover closures from the oil separator flanges and wipe all connection surfaces clean. Lower the oil separator carefully keeping it level and horizontal to the condenser shell. Line up the compressor discharge port with the oil separator connection. Push the oil separator connection until it seats itself. Use cap screws and washers to fasten the oil separator connection to the compressor. Complete the connection to the condenser shell using cap screws and nuts. Keep hoist rigging attached to the oil separator.
13. Fasten the support bracket between the condenser and the end of the oil separator with the proper hardware.
14. Tighten all screws and nuts on the discharge flange and the support bracket.
15. Assemble the Control Center to the unit (Refer to Figure. 9). Also refer to Forms 160.81-PW1 or 160.81-PW2.
16. **Solid State Starter (Optional)** – Install starter per Figure 9. Also install piping connections.
17. Install refrigerant piping, oil lines, and oil return system filters.
18. Pressure test. *NOTE: Relief valves must be plugged (or capped).* Refer to the *Maintenance* Section of this manual.
19. Evacuate and charge with refrigerant.
20. Charge the oil separator with the proper type and quantity of YORK oil.
21. **All Units** – Complete installation and finally level the unit. Refer to the *Installation* Section of this manual.

FORM 7 FIELD ASSEMBLY PARTS:

ITEM NO.	DESCRIPTION
1	COMPRESSOR WITH MOTOR
2	GASKET
3	DISCHARGE LINE
4	SCREW
5	NUT
6	LOCKWASHER
7	VALVE, BUTTERFLY
8	SCREW
9	SCREW
10	OIL SEPARATOR
11	NUT
12	SCREW
13	STUD
14	SEAL, O-RING
15	HOT GAS BYPASS
16	CONDENSER
17	STARTER
18	CONTROL PANEL
19	LIQUID LINE
20	NUT
21	GASKET
22	SCREW
23	EVAPORATOR
24	GASKET
25	ISOLATOR KIT
26	WASHER
27	STRAINER
28	SHIMS
29	STUD

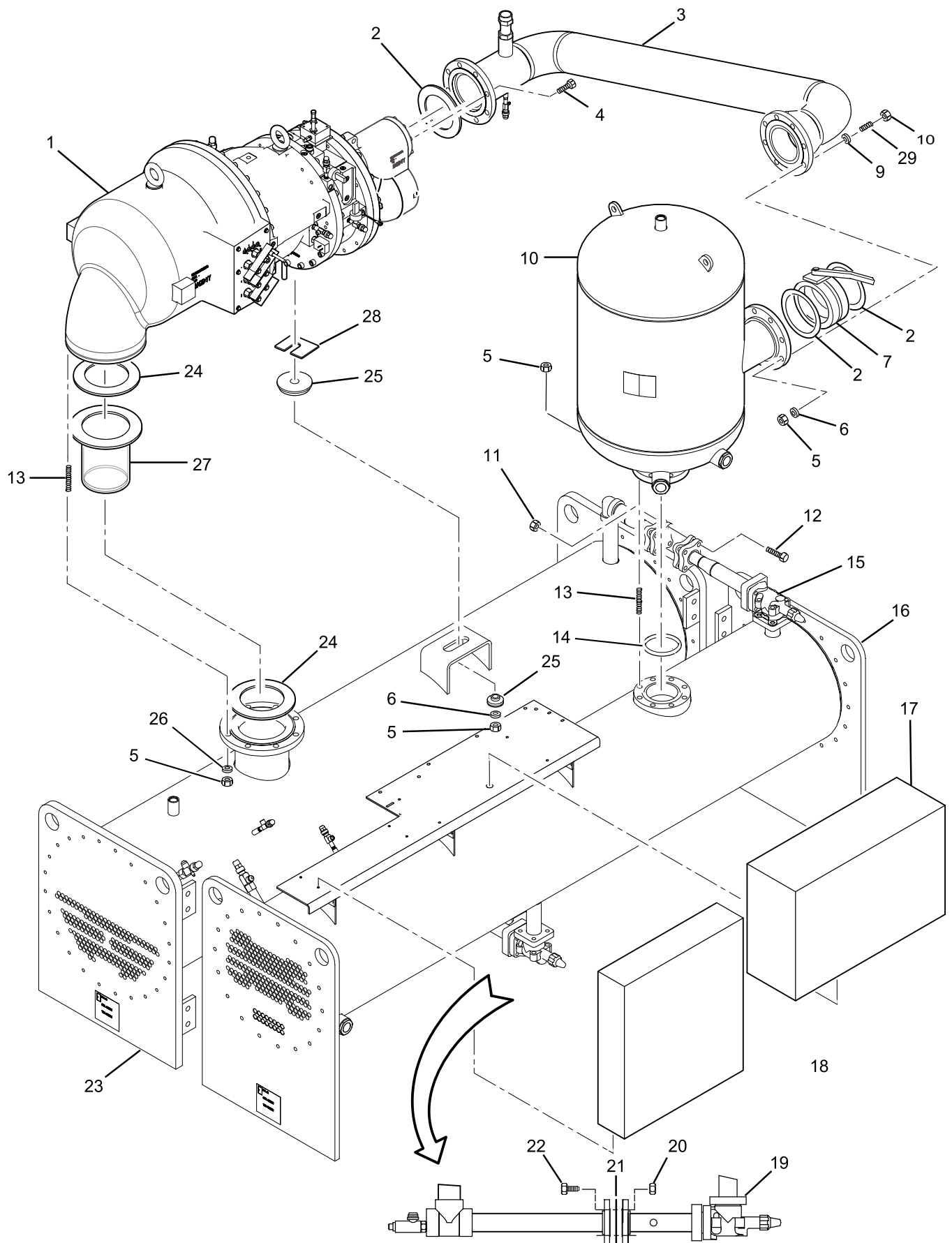

FIG. 9 – FORM 7 FIELD ASSEMBLY – EXPLODED VIEW

LD11009

Form 8 Shipment

1. Assemble vibration isolators to the unit. (Refer to the *Isolator Pads* Section of this manual)
2. Level shells in both directions. The longitudinal alignment of the shell should be checked by placing a level on the top of the shell, next to the discharge connection. The transverse alignment should be checked by placing a level on the tops of both end sheets. After shell is leveled, wedge and shim each corner of the shell to solidly support it while assembling the other parts.
3. Remove all cover closures from the oil separator flanges and wipe all connection surfaces clean. Lower the oil separator carefully keeping it level and horizontal to the condenser shell. Line up the compressor discharge port with the oil separator connection. Push the oil separator connection until it seats itself. Use cap screws and washers to fasten the oil separator connection to the compressor. Complete the connection to the condenser shell using cap screws and nuts. Keep hoist rigging attached to the oil separator. (Refer to Figure 10)

FORM 8 FIELD ASSEMBLY PARTS:

ITEM NO.	DESCRIPTION
1	COMPRESSOR WITH MOTOR
2	GASKET
3	DISCHARGE LINE
4	SCREW
5	NUT
6	LOCKWASHER
7	VALVE, BUTTERFLY
8	SCREW
9	SCREW
10	OIL SEPARATOR
13	STUD
14	SEAL, O-RING
15	HOT GAS BYPASS
16	CONDENSER
23	EVAPORATOR
29	STUD

OIL QUANTITIES

COMPRESSOR CODE	FORM 2 SHIPMENT			FORM 3, 7, AND 8		
	PART NUMBER	GAL	CONTAINER QTY	PART NUMBER	GAL	CONTAINER QTY
T0	011 00549 000	9	2	011 00549 000	9	2
T1	011 00549 000	9	2	011 00549 000	9	2
T2	011 00549 000	15	3	011 00549 000	15	3
T3	011 00549 000	15	3	011 00549 000	15	3

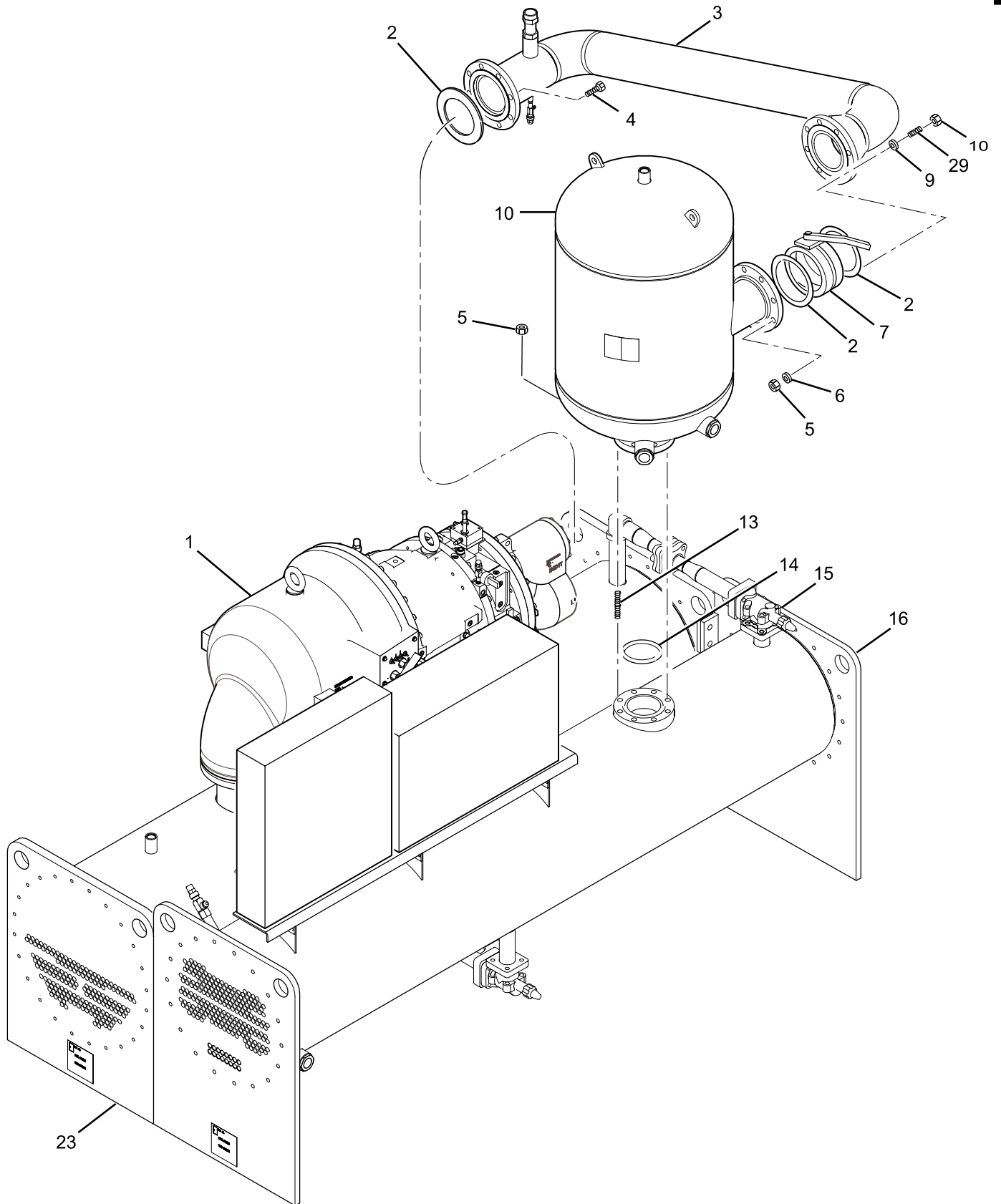

FIG. 10 – FORM 8 FIELD ASSEMBLY – EXPLODED VIEW

VACUUM DEHYDRATION

To obtain a sufficiently dry system, the following instructions have been assembled to provide an effective method for evacuating and dehydrating a system in the field. Although there are several methods of dehydrating a system, we are recommending the following, as it produces one of the best results, and affords a means of obtaining accurate readings as to the extent of dehydration.

The equipment required to follow this method of dehydration consists of a wet bulb indicator or vacuum gauge, a chart showing the relation between dew point temperature and pressure in inches of mercury (vacuum), (see last page) and a vacuum pump capable of pumping a suitable vacuum on the system.

OPERATION

Dehydration of a refrigeration system can be obtained by this method because the water present in the system reacts much as a refrigerant would. By pulling down the pressure in the system to a point where its saturation temperature is considerably below that of room temperature, heat will flow from the room through the walls of the system and vaporize the water, allowing a large percentage of it to be removed by the vacuum pump. The length of time necessary for the dehydration of a system is dependent on the size or volume of the system, the capacity and efficiency of the vacuum pump, the room temperature and the quantity of water present in the system. By the use of the vacuum indicator as suggested, the test tube will be evacuated to the same pressure as the system, and the distilled water will be maintained at the same saturation temperature as any free water in the system, and this temperature can be observed on the thermometer.

If the system has been pressure tested and found to be tight prior to evacuation, then the saturation temperature recordings should follow a curve similar to the typical saturation curve shown as Fig. 11.

The temperature of the water in the test tube will drop as the pressure decreases, until the boiling point is reached, at which point the temperature will level off and remain at this level until all of the water in the shell is vaporized. When this final vaporization has taken place the pressure and temperature will continue to drop until eventually a temperature of 35°F (2°C) or a pressure of 5mm Hg. is reached.

When this point is reached, practically all of the air has been evacuated from the system, but there is still a small amount of moisture left. In order to provide a medium for carrying this residual moisture to the vacuum pump, nitrogen should be introduced into the system to bring it to atmospheric pressure and the indicator temperature will return to approximately ambient temperature. Close off the system again, and start the second evacuation.

The relatively small amount of moisture left will be carried out through the vacuum pump and the temperature or pressure shown by the indicator should drop uniformly until it reaches a temperature of 35°F (2°C) or a pressure of 5mm Hg.

When the vacuum indicator registers this temperature or pressure it is a positive sign that the system is evacuated and dehydrated to the recommended limit. If this level can not be reached, it is evident that there is a leak somewhere in the system. Any leaks must be corrected before the indicator can be pulled down to 35°F (2°C) or 5mm Hg. in the primary evacuation. During the primary pulldown keep a careful watch on the wet bulb indicator temperature, and do not let it fall below 35°F (2°C) . If the temperature is allowed to fall to 32°F (0°C) the water in the test tube will freeze, and the result will be a faulty temperature reading.

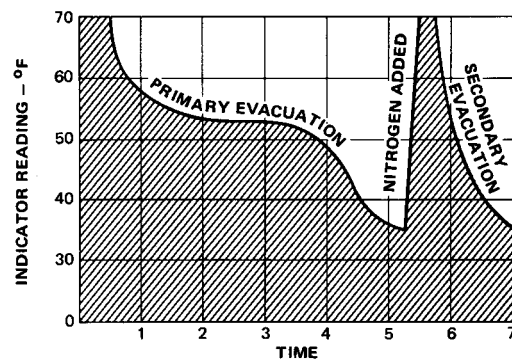

FIG. 11 – SATURATION CURVE

LD00474

SYSTEMS PRESSURES

1

*GAUGE	ABSOLUTE			BOILING TEMPERATURES OF WATER °F
INCHES OF MERCURY (HG) BELOW ONE STANDARD ATMOSPHERE	PSIA	MILLIMETERS OF MERCURY (HG)	MICRONS	
0	14.696	760	760,000	212
10.24*	9.629	500	500,000	192
22.05*	3.865	200	200,000	151
25.98*	1.935	100	100,000	124
27.95*	.968	50	50,000	101
28.94*	.481	25	25,000	78
29.53*	.192	10	10,000	52
29.67*	.122	6.3	6,300	40
29.72*	.099	5	5,000	35
29.842*	.039	2	2,000	15
29.882*	.019	1.0	1,000	+1
29.901*	.010	.5	500	-11
29.917*	.002	.1	100	-38
29.919*	.001	.05	50	-50
29.9206*	.0002	.01	10	-70
29.921*	0	0	0	

**WATER
FREEZES**

* One standard atmosphere = 14.696 PSIA
= 760 mm Hg. absolute pressure at 32°F
= 29.921 inches Hg. absolute at 32°F

NOTES: PSIG = Lbs. per sq. in. gauge pressure
= Pressure above atmospheric
PSIA = Lbs. per sq. in. absolute pressure
= Sum of gauge plus atmospheric pressure

PIPING CONNECTIONS

After the unit is leveled (and wedged in place for optional spring isolators) the piping connections may be fabricated; chilled water, condenser water and refrigerant relief. The piping should be arranged with offsets for flexibility, and adequately supported and braced independently of the unit to avoid strain on the unit and vibration transmission. Hangers must allow for alignment of pipe. Isolators (by others) in the piping and hangers are highly desirable, and may be required by specifications. This is done to effectively utilize the vibration isolation characteristics of the isolator mounts on the unit.

CHECK FOR PIPING ALIGNMENT

When piping is complete, check for alignment. Try opening a connection in each line, as close to the unit as possible, by removing the flange bolts or coupling. If any of the bolts are bound in their holes, or if the connection springs are out of alignment, the misalignment must be corrected by properly supporting the piping or by applying heat to anneal the pipe.



It may be necessary to weld chilled water or condenser water piping directly to the water pipe nozzles. Since chilled and condenser water temperature sensor wells are often in close proximity to these connection points, sensors in the wells may often see temperatures of several hundred degrees. We have reason to believe that some potential exists for damaging these sensors from the transferred heat. Any damage will most likely show up as error in the sensor.

It is advisable to remove the sensors from the wells during the welding process as a precautionary measure. If the sensor is removed, assure that it bottoms out when it is placed back in the well.



If the piping is annealed to relieve stress, the inside of the pipe must be cleaned of scale before it is finally bolted in place.

EVAPORATOR AND CONDENSER WATER PIPING

YR chillers have evaporator and condenser liquid heads with nozzles that are grooved for the use of victaulic couplings. The nozzles are also suitable for welding Class 150 PSIG (1034 kPa) flanges.

The nozzles and water pass arrangements are furnished in accordance with the job requirements (see Product Drawing, Form 160.81-PA1). Standard units are designed for 150 PSIG (1034 kPa) DWP on the water side. If job requirements are for greater than 150 PSIG (1034 kPa) DWP, check the unit data plate to determine if the unit has provisions for the required DWP before applying pressure to evaporator or condenser.

Foreign objects which could lodge in, or block flow through, the evaporator and condenser tubes must be kept out of the water circuit. All water piping must be cleaned or flushed before being connected to the unit, pumps, or other equipment.

Permanent strainers (by others) are required in both the evaporator and condenser water circuits to protect the unit as well as the pumps, tower spray nozzles, chilled water coils and controls, etc. (The strainer, should be installed in the entering chilled water line, directly upstream of the unit.)

Water piping circuits should be arranged so that the pumps discharge through the unit. The circuits should be controlled as necessary to maintain essentially constant chilled and condenser water flows through the unit at all load conditions.

If pumps discharge through the unit, the strainer may be located upstream from the pumps to protect both pump and unit. (Piping between the strainer, pump and unit must be very carefully cleaned before start-up.) If pumps are remotely installed from the unit, strainers should be located directly upstream.

Chilled Water Circuit

The minimum velocity through the tubes is 3 FPS (feet per second) (0.914 MPS - meters per second), so chilled water piping designs for variable flow should be selected with higher velocities at design conditions. The rate of change should be slow, to make sure that the chiller controls can track the load.

The following is a guideline for an allowable variable flow rate of change. This may require modification based on specific design application.

The maximum allowable rate of change is 15 minutes to go from 10% to 50% of design flow, based on a minimum chilled water system turnover rate of 15 minutes. System turnover rate (STR) is a measure of the chilled water system volume as compared to the design chilled water flow rate, and is defined as:

$$\text{System Turnover Rate (STR)} = \frac{\text{Volume of chilled water system (gallons)}}{\text{Design chilled water flow rate (gpm)}}$$

As noted previously, if the STR is above 15 minutes, chilled water flow rate of change is 15 minutes. If STR goes below 15 minutes, chilled water flow rate of change must be modified as follows:

$$\text{Rate of Change from 100\% to 50\% Flow (minutes)} = 15 + 15 - \text{STR}$$

Chilled water supply must leave the evaporator through the connection marked "Liquid Outlet". Chilled water return must enter the evaporator through the connection marked "Liquid Inlet".

Condenser water supply must enter the condenser through the connection marked "Liquid Inlet". Condenser water return must leave the condenser through the connection marked "Liquid Outlet".

TABLE 5 – WATER FLOW RATE LIMITS – GPM (L/S)

SHELL CODE	PASS	EVAPORATOR		CONDENSER	
		MINIMUM	MAXIMUM	MINIMUM	MAXIMUM
TB, VB	1	383 (24.2)	1525 (96.2)	613 (38.7)	2204 (139.1)
	2	192 (12.1)	762 (48.1)	307 (19.4)	1102 (69.5)
	3	128 (8.1)	508 (32.1)	205 (12.9)	734 (46.3)
TC, VC	1	468 (29.5)	1866 (118.0)	683 (43.1)	2455 (154.9)
	2	234 (14.8)	932 (58.8)	342 (21.6)	1227 (77.4)
	3	157 (9.9)	621 (39.2)	228 (14.4)	818 (51.6)
TD, VD	1	570 (36.0)	2277 (143.7)	771 (48.7)	2774 (175.0)
	2	286 (18.0)	1138 (71.8)	386 (24.4)	1386 (87.5)
	3	—	—	—	—
WB, XB	1	693 (43.7)	2771 (174.9)	866 (54.6)	3462 (218.5)
	2	346 (21.8)	1385 (87.4)	433 (27.3)	1731 (109.2)
	3	231 (14.6)	924 (58.3)	289 (18.2)	1154 (72.8)
WC, XC	1	822 (51.9)	3287 (207.4)	1082 (68.3)	4328 (273.1)
	2	411 (25.9)	1644 (103.7)	541 (34.1)	2164 (136.5)
	3	274 (17.3)	1096 (69.2)	361 (22.8)	1443 (91.1)
WD, XD	1	986 (62.2)	3945 (248.9)	1350 (85.2)	5400 (340.1)
	2	493 (31.1)	1972 (124.4)	675 (42.6)	2700 (170.0)
	3	—	—	—	—

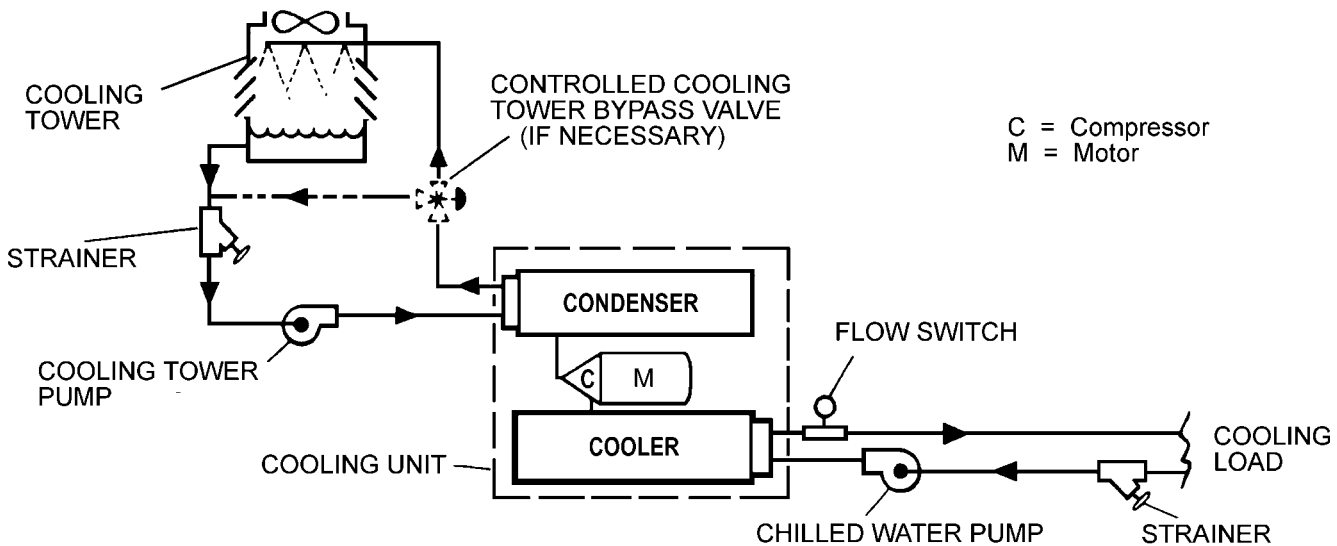

LD07069

FIG. 12 – SCHEMATIC OF A TYPICAL PIPING ARRANGEMENT

Condenser Water Circuit

For proper operation of the unit, condenser refrigerant pressure must be maintained above evaporator pressure. If operating conditions will fulfill this requirement, no attempt should be made to control condenser water temperature by means of automatic valves, cycling of the cooling tower fan or other means. YR chillers are designed to function satisfactorily and efficiently, when condenser water is allowed to seek its own temperature level at reduced loads and off-peak seasons of the year. YR Chillers can be operated with entering condensing water temperature that is less than design conditions. The following formula is used to calculate the minimum entering condensing water temperature.

R-134a Refrigerant

ECW minimum =

$$LCWT + 16 + [(\% \text{ of load} / 100) \times (10 - \text{full load condenser water } \Delta T)]$$

Where:

ECW minimum = Minimum Entering Condensing Water Temperature °F

LCWT = Leaving Chilled Water Temperature °F

This is a guideline for estimating ECW minimum. Actual ECW minimum will vary.



Operating the chiller below its minimum ECW could result in “Low Oil Differential” shut downs. There are different methods used to maintain minimum ECW, however the most effective is to install a three-port by-pass valve in the leaving condenser water line. Refer to Fig 12a.



Operating below the minimum entering condensing water will not provide energy savings and will result in oil management problems. However, if entering condenser water temperature can go below the required minimum, condenser water temperature must be maintained equal to or slightly higher than the required minimum. Refer to Figure 12.

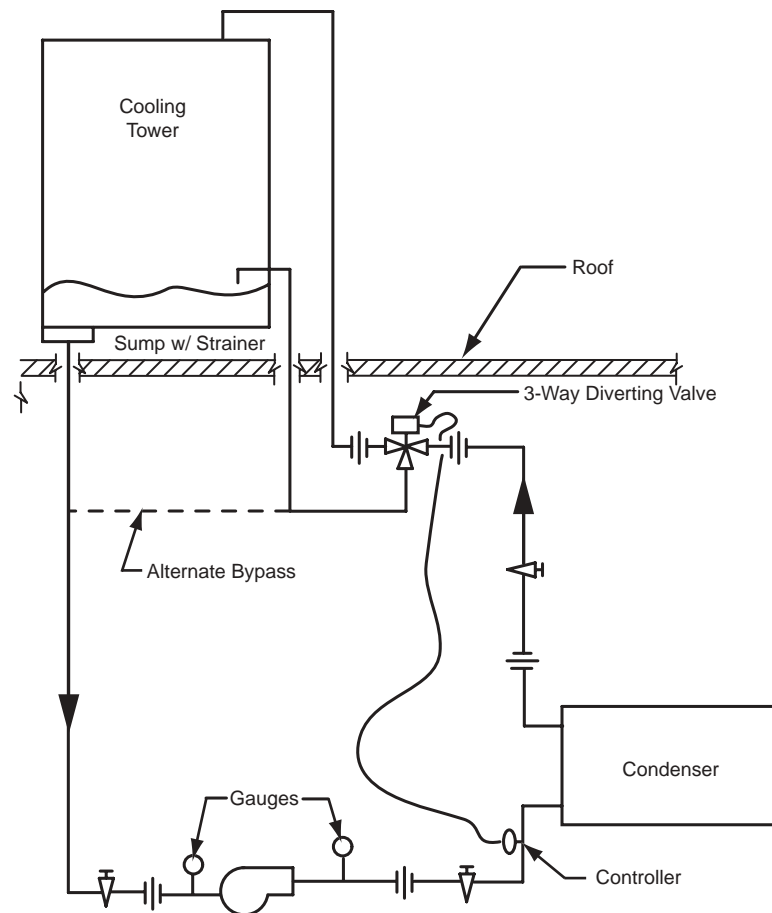

LD10024

FIG. 12A – COOLING TOWER PIPING WITH 3 PORT BY-PASS VALVE

Special entering condensing water temperature controls may be required when long condensing water circuits are used and the chiller is being started with minimum load available.

Stop Valves

Stop valves may be provided (by others) in the evaporator and condenser water piping, adjacent to the unit to ease maintenance. Pressure taps should be provided (by others) in the piping as close to the unit as possible, to aid in obtaining operating checks.

Flow Switches (Field Installed)

A flow switch or pressure differential control in the chilled water line(s), adjacent to the unit, is an accessory which can be provided by YORK for connection to the control center. If a flow switch is used, it must be directly in series with the unit and sensing only water flow through the unit. The differential switch must sense pressure drop across the unit.

Drain and Vent Valves

Drain and vent valves (by others) should be installed in the connections provided in the evaporator and condenser liquid heads. These connections may be piped to drain if desired.

Checking Piping Circuits and Venting Air

After the water piping is completed, but before any water box insulation is applied, tighten and torque the nuts on the liquid head flanges (to maintain between 30 and 60 ft. lbs. / 41 and 81 mm). Gasket shrinkage and handling during transit may cause nuts to loosen. If water pressure is applied before this is done, the gaskets may be damaged and have to be replaced. Fill the chilled and condenser water circuits, operate the pumps manually and carefully check the evaporator and condenser water heads and piping for leaks. Repair leaks as necessary.

Before initial operation of the unit both water circuits should be thoroughly vented of all air at the high points.



Piping should be properly supported to prevent any strain on relief valve mounting.

REFRIGERANT RELIEF PIPING

Each unit is equipped with relief device(s) on the evaporator, condenser and oil separator for the purpose of quickly relieving excess pressure of the refrigerant charge to the atmosphere in case of an emergency. The relief valve is furnished in accordance with American Society of Heating, Refrigeration and Air Conditioning Engineers Standard 15 (ASHRAE 15) and set to relieve at 235 PSIG (1621 kPa).

Refrigerant relief vent piping (by others), from the relief valves to the outside of the building, is required by code and must be installed on all units. Refer to Figure 13 and Table 6. For additional information on relief valve discharge line sizing, refer to ASHRAE-15 addendum 15C and 15D-2000 section 9.7.8.5.

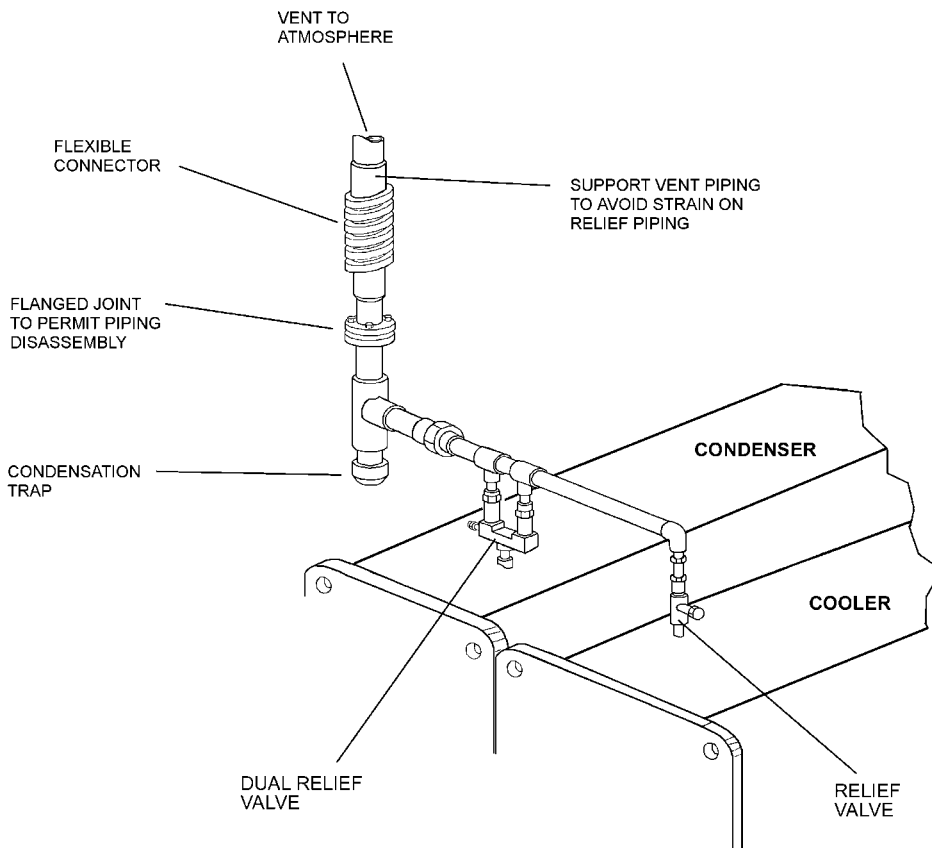

FIG. 13 – TYPICAL REFRIGERANT VENT PIPING FROM RELIEF VALVES

LD04896

TABLE 6 – REFRIGERANT RELIEF CHARACTERISTICS

SHELL CODE	Evaporator				
	C	SINGLE RELIEF VALVE		DUAL RELIEF VALVE ¹	
		Cr	OUTLET	Cr	OUTLET
	LBS. AIR PER MIN.	NPT	LBS. AIR PER MIN.	NPT	
T	34.7	55.9	1-11-1/2 (FEM)	55.9	1-11-1/2 (FEM)
V	48.5	55.9	1-11-1/2 (FEM)	55.9	1-11-1/2 (FEM)
W	48.0	91.8	1-1/4 - 11-1/2 (FEM)	91.8	1-1/4 - 11-1/2 (FEM)
X	64.0	91.8	1-1/4 - 11-1/2 (FEM)	91.8	1-1/4 - 11-1/2 (FEM)

Where:

Cr = Rated capacity of YORK supplied relief valve at 235 PSIG.

Relief valve set pressure - 235 PSIG (1,621 kPa).

CONDENSER

SHELL CODE	C	DUAL RELIEF VALVE ¹	
		Cr	OUTLET
	LBS. AIR PER MIN.	NPT	
T	42.1	55.9	1-11-1/2 (FEM)
V	53.8	55.9	1-11-1/2 (FEM)
W	59.4	91.8	1-1/4 - 11-1/2 (FEM)
X	73.3	91.8	1-1/4 - 11-1/2 (FEM)

NOTES:

1. Dual relief valve consists of one three-way shut-off valve and two single relief valves. The valve configuration will not allow both valves to be shut off at the same time, and valves are sized such that each relief valve has sufficient discharge capacity when used alone. This permits safe removal of either relief valve for repair or replacement, while maintaining vessel protection.
2. ASHRAE 15-1994 Section 9.8 and Appendix F describes relief requirements for positive displacement compressors. Summarized, the unit must be equipped with a relief device suitable for relieving the entire compressor capacity.

UNIT PIPING

Compressor lubricant piping and system refrigerant piping are factory installed on all units shipped assembled. On units shipped dismantled, the following piping should be completed under the supervision of the YORK representative; the lubricant piping; system oil return using material furnished.

CONTROL WIRING

After installation of the control center on units shipped disassembled, the control wiring must be completed between unit components and control center or solid state starter when used, using the wiring harness furnished.

Field wiring connections for commonly encountered control modifications (by others), if required, are shown on Wiring Diagram, Form 160.81-PW5.

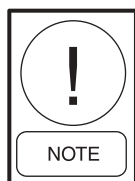

No deviations in unit wiring from that shown on drawings furnished shall be made without prior approval of the YORK Representative.

POWER WIRING

Unit With Electro-Mechanical Starter

A 115 volt – single-phase – 60 or 50 Hertz power supply of 15 amperes must be furnished to the control center, from the control transformer (1-1/2 kVa required) included with the compressor-motor starter. DO NOT make final power connections to control center until approved by YORK Representative. Refer to Form 160.81-PW3, *Power Wiring*. YORK recommends that all connections to the unit be flexible. Consult with and conform to all local regulatory requirements.

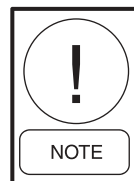

Remote Electro-Mechanical Starters for the YR Unit must be furnished in accordance with YORK Standard .

Each YR unit is furnished for a specific electrical power supply as stamped on the unit data plate, which also details the motor connection diagrams.

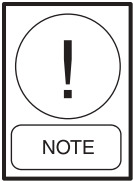

To ensure proper motor rotation, the starter power input and starter to motor connections must be checked with a phase sequence indicator in the presence of the YORK Representative.



IMPORTANT: DO NOT cut wires to final length or make final connections to motor terminals or starter power input terminals until approved by the YORK Representative.

Figure 14 shows the power wiring hook-up for YR Motor Connections. (Refer to Wiring Labels in Motor Terminal Box for hook-up to suit motor voltage and amperage.)

Unit With Solid State Starter (Optional)

A YR unit equipped with a Solid State Starter, does not require wiring to the compressor-motor. The motor

power wiring is factory connected to the Solid State Starter. All wiring to the control panel is completed by the factory. A control transformer is furnished with the Solid State Starter. Refer to Form 160.81-PW1.

INSULATION

Insulation of the type specified for the job, or minimum thickness to prevent sweating of 30°F (-1° C) surfaces (water chill application), should be furnished (by others) and applied to the evaporator shell, end sheets, liquid feed line to flow chamber, compressor suction connection, and evaporator liquid heads and connections. The liquid head flange insulation must be removable to allow head removal for tube maintenance. Details of areas to be insulated are given in Product Drawing, Form 160.81-PA1.

Units can be furnished, factory anti-sweat insulated, on order at additional cost. This includes all low temperature surfaces except the two evaporator liquid heads.



IMPORTANT: DO NOT field insulate until the unit has been leak tested under the supervision of the YORK Representative.

INSTALLATION CHECK – REQUEST FOR START-UP SERVICE

After the unit is installed, piped and wired as described in this Instruction, but before any attempt is made to start the unit, the YORK District Office should be advised so that the start-up service, included in the contract price, can be scheduled. Notification to the YORK Office should be by means of Installation Check List and Request, Form 160.81-CL1, in triplicate.

The services of a YORK Representative will be furnished to check the installation and supervise the initial start-up and operation on all YR units installed within the Continental United States.

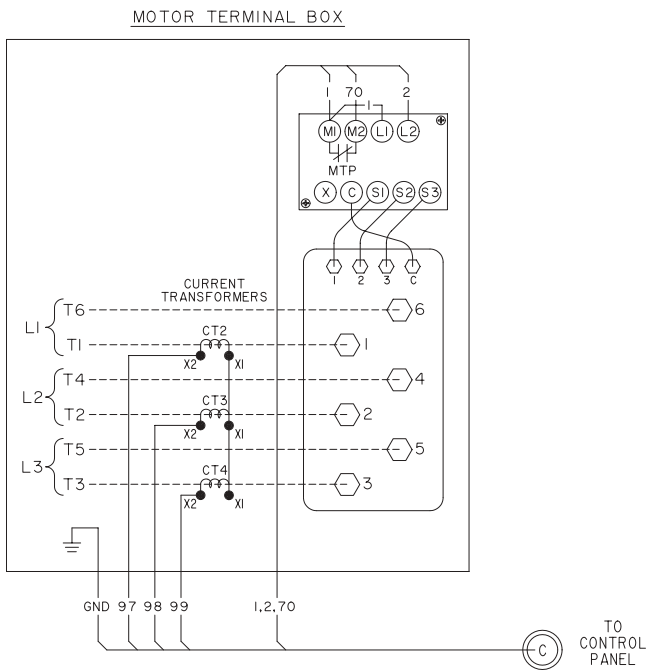

LD07070

FIG. 14 – YR MOTOR CONNECTIONS (ELECTRO-MECHANICAL STARTER)

MODEL YR	YORK®	MaxE™
-----------------	--------------	--------------

INSTALLATION CHECK LIST AND REQUEST FOR AUTHORIZED START-UP ENGINEER

*TO: _____ JOB NAME: _____
 _____ LOCATION: _____
 _____ CUSTOMER ORDER NO. _____

YORK TEL. NO. _____ YORK ORDER NO. _____ YORK CONTRACT NO. _____

CHILLER
MODEL NO. _____ SERIAL NO. _____
The work (as checked below) is in process and will be completed by _____ / _____ / _____ <div style="text-align: right; font-size: small;">Month / Day / Year</div>

The following work must be completed in accordance with installation instructions:

- A. YORK CHILLER**
 - 1. Unit assembled (if shipped dismantled) and refrigerant piping installed under YORK supervision.....
 - 2. Vibration isolator mounts so the unit is level, and isolators equally deflected.....
- B. WATER PIPING**
 - 1. Condenser water piping installed between condenser, pumps and cooling tower
 - 2. Chilled water piping installed between evaporator, pumps, and cooling coils.....
 - 3. Make-up and fill lines installed to cooling tower and chilled water system
 - 4. All water piping checked for strain – Piping should not spring when connections are broken at unit
 - 5. Water piping leak tested and flushed, and water strainers cleaned after flushing. Piping systems filled with water and trapped air vented.....
 - 6. Chilled and condenser water flow available to meet unit design requirements
- C. REFRIGERANT RELIEF PIPING (when required)**
 - 1. Refrigerant relief piping (with flexible connection) installed from unit to atmosphere (per ASHRAE-15)
- D. ELECTRICAL WIRING**
 - 1. ELECTRO-MECHANICAL STARTER
 - a. Main and control power supply available.....
 - b. Compressor motor starter furnished in accordance with, YORK Standard R-1079 – Form 160.47-PA5.1
 - c. Wiring completed from main power supply to starter – **but not cut to length or connected to starter**
 - d. Wiring completed from starter to compressor motor – **but not cut to length or connected to motor**
 - e. 115 volt service completed to Control Center – **but not connected**
- 2. SOLID STATE STARTER
 - a. Main and control power supply available.....
 - b. Wiring completed from main power supply to solid state starter – **but not cut to length or connected to starter**
- 3. CONTROL CENTER
 - a. Jumper wire NOT installed between terminal 24 and 25 located on the control center terminal strip
 - b. External control wiring completed from the control center to chilled water flow switches or interlocks in accordance with the YORK Wiring Diagram.....
 - c. Power available and wiring completed to the following starters and motors, and rotation of each checked
 - 1. Chilled water pump(s).....
 - 2. Condenser water pump(s).....
 - 3. Cooling tower fan.....
 - d. Meg ohm meter available for checking motor windings.....
- E. TESTING, EVACUATION AND CHARGING (Under YORK Supervision if Unit Shipped Less Refrigerant or Dismantled)**
 - 1. R-134a available for testing.....
 - 2. Dry Nitrogen available for testing
 - 3. A high vacuum pump available for evacuation and dehydration of system
 - 4. R-134a (Supplied by YORK available for charging)
 - 5. Unit (ready to be) (has been) pressure tested, evacuated, dehydrated and charged
- F. CONDITIONS**
 - 1. YORK oil for compressor on job
 - 2. Cooling load available for testing and operating unit.....
 - 3. Personnel available for final wiring connections.....
 - 4. Personnel available for start-up and testing
 - 5. Owners operating personnel for instruction.....

Names: _____

With reference to the terms of the above contract, we are requesting the presence of your Authorized Representative at the job site on Month _____ / Day _____ / Year _____ to start the system and instruct operating personnel

HAVE HIM CONTACT _____
Names

We understand that the services of the YORK Authorized Representative will be furnished in accordance with the contract for a period of not more than _____ consecutive normal working hours, and we agree that a charge of _____ per diem plus travel expenses will be paid to YORK if services are required for longer than _____ consecutive normal hours or if repeated calls are required.

Signed: _____
Title: _____



INSTRUCTIONS FOR USE OF FORM

YORK REGIONAL OR DISTRICT SERVICE OFFICE

1. Fill in the blanks at the top of the form.
 * To: (Service Managers Name and YORK office address)
 YORK TELEPHONE NO.
 JOB NAME
 LOCATION
 CUSTOMER ORDER NO.
 YORK ORDER NO.
 YORK CONTRACT NO.
 SYSTEM MODEL NO.
2. Completely rule out or "XXXX" out items on check list that do NOT apply to this specific job. (Review Para. A-1, A-2, D-1b, D-2, D-3, E, E-1, E-2, E-3, E-4, & E-5).
3. Fill in terms of contract at bottom of pages as to hours of supervision to be furnished and per diem charges for additional time. (There is some room for additional terms, if applicable – travel expenses, for instance).
4. Retain in files and copy the contractor.

NOTE: After completion of start-up, write in the date of start-up at the bottom, insert Unit Serial Number and send to YORK A.S. Service Manager, York, PA.

CUSTOMER

This installation Check List provides you with a quick, convenient way to check whether all of the necessary installation work has been completed in accordance with YORK Installation Instructions, and when completed, acts as a request for the start-up supervision to be furnished by YORK.

Complete the form as follows:

1. In the box at the top of the page, enter Unit Serial No. (from Unit Data Plate) and date work will be completed.
2. Check off each item as completed.
3. Item F-5 – Enter names of owner/operator's personnel who have been assigned to be present at time of start-up for instruction in proper operation of the YORK Millennium chiller.
4. Bottom of form – Enter date YORK Supervisor should be at job site and name(s) of your supervisor(s) he should contact.
5. Sign the request form and return to the local York Service Manager. Please give as much advance warning as possible so that we can give you the service you want, when you want it. Thank you.

SECTION 2 – CHILLER COMMISSIONING

OPTIVIEW CONTROL CENTER

Refer to Operator's manual (Form 160.81-O1) and Service manual (Form 160.81-M1) for more information concerning the OptiView Control Center.

YR CHILLERS PRE-STARTUP CHECKLIST

Installation

- Check all utility interconnections to the chiller: water piping, electrical and control wiring to the chiller.
- Verify that the chiller is level.
- Check the mounting spring isolators or vibration isolators for equal loading.
- Check the relief valve piping for excessive load on the relief devices.

Form 2, Form 3, Form 7 and 8 Shipments

- A Vacuum Dehydration Unit is required for all field re-assembled YR Chillers; Form 3 and Form 7. In addition, Form 2 YR Chillers shipped without refrigerant require a Vacuum Dehydration procedure prior to commissioning. Refer to the *Shipping Forms* section of this manual.

Evaporator and Condenser Flow Rates

- Check for properly installed and clean strainers in the water supply lines to the evaporator and condenser. Clean and properly installed water strainers is a YORK warranty requirement.

CONDENSER

Low Temperature Brine Chillers

- Verify the freeze point of the brine in the evaporator. Use a hand-held optical refractometer or a hydrometer.

Compressor

- Make certain the incoming electrical power disconnect is in the open position.

MOTOR

Motor

- Check the voltage supply to make certain it is the same as the Motor Nameplate Data.

Refrigerant Leak Check

- Thoroughly leak check the entire chiller for leaks prior to starting. Make certain to include relief valves. This may require removing field-installed relief valve piping.

Compressor Oil

- Check the compressor oil level. Oil should be visible in the lower sight glass on the side of the oil separator. Refer to section 5, *Oil Level* in this manual.
- Make certain that the oil heater has been energized at least 24 hours prior to starting the chiller.

Cooling Tower

- Verify that the cooling tower is operational and the fans and controls are ready for the chiller to be started.

Water Treatment

- Make certain the water treatment is in place and operational.

Wiring

- Check and verify all interconnecting wiring with the wiring diagram.
- Make certain all wire terminals are tight and plugs are properly secured.

Capacity Control Block

- Make certain the three service valves are back seated.

START-UP

1. If the chilled water pump is manually operated, start the pump – the OptiView Control Center will not allow the chiller to start unless chilled liquid flow is established through the unit. (A field installed chilled water flow switch is required.) If the chilled liquid pump is wired to the OptiView Control Center the pump will automatically start; therefore, this step is not necessary.
2. To start the chiller, place the START/STOP control in the START position. This switch will automatically spring return to the RUN position. When the START switch is energized, the control center is placed in an operating mode and the “START SEQUENCE INITIATED” will be displayed. Any malfunction will be noted by messages on the 40 character alphanumeric display.

CHECKING OPERATION

During operation, the following conditions should be checked:

1. On starting, the slide valve should remain unloaded until the compressor motor is up to speed on the run winding; then the slide valve solenoid valve causes the slide valve to load and unload the compressor as required to maintain the leaving chilled water temperature equal to the leaving water temperature setpoint.

2. Check Oil Pressure Display. The oil and oil filter transducers are compared during compressor operation. A gradual decrease in bearing pressure of 5 to 10 PSI (34 to 69 kPa) (with constant suction and discharge pressures) may be an indication of a dirty filter. The filter should be replaced when pressure loss is 30% of the original pressure. The actual bearing oil pressure will vary with compressor suction and discharge pressures. When a new system is first operated under normal full load conditions, the bearing oil pressure should be recorded as a reference point with which to compare subsequent readings.

OPERATING LOG SHEET

A permanent daily record of system operating conditions (temperatures and pressures) recorded at regular intervals throughout each 24 hour operating period should be kept.

An optional status printer is available for this purpose, a log sheet can be used by YORK personnel for recording test data on chiller systems. It is available from the factory in pads of 50 sheets each under Form No. 160.81-CL1, and may be obtained through the nearest YORK office. Automatic data logging is possible by connecting the optional printer and programming the DATA LOGGER function (Refer to Form 160.81-O1, Section 3).

PRE-START CHECKLIST

All checkpoints in the following list **must** be completed before placing the Rotary Screw Liquid Chiller in op-

eration. Only when the checklist is **completed** will the unit be ready for initial start-up.

CHECKPOINTS	
<input type="checkbox"/>	Pressure test before introducing pressure to unit, and check for leaks.
<input type="checkbox"/>	Confirm motor disconnect is open.
<input type="checkbox"/>	Confirm oil level is between the two sight glasses on the oil separator.
<input type="checkbox"/>	Confirm all field wiring connections have been made.
<input type="checkbox"/>	Confirm Control Center display is operating.
<input type="checkbox"/>	Confirm pressures and temperatures are consistent with anticipated ranges. Confirm heater is operating.
<input type="checkbox"/>	Open discharge service valve.
<input type="checkbox"/>	Confirm the COM, LP, HP ports on the capacity control block valve are back seated.
<input type="checkbox"/>	Confirm all oil return system service valves are open.
<input type="checkbox"/>	Confirm liquid injection service valves are open.
<input type="checkbox"/>	Close motor main disconnect.

An accurate record of readings serves as a valuable reference for operating the system. Readings taken when a system is newly installed will establish normal conditions with which to compare later readings.

For example, dirty condenser tubes may be indicated by higher than normal temperature differences between leaving condenser water and refrigerant leaving the condenser.

CHILLER COMMISSIONING

This checklist is provided as a guide to the service technician to ensure the YR Chiller is properly commissioned. Refer to Form 160.81-CL1.

YR CHILLER START-UP

Start

- ✓ Start the chiller and operate the chiller at design conditions or at the maximum load conditions available.

OptiView Control Center

- ✓ Recheck the setpoints and programmable functions of the OptiView Control Center. Change as necessary to match the operating conditions.

Print

- ✓ Use the OptiView Control Center print feature to print a copy of all operating data.
- ✓ Print a copy of the Sales Order Screen.

Important: Save the hard copies of the operating data and the Sales Order screen. Maintain a file in the local YORK Service Office.

Leak Check (Visual)

- ✓ Thoroughly check all fittings and connections for oil and refrigerant leaks.

CUSTOMER (OPERATING PERSONNEL) INSTRUCTION

2

Operation

- ✓ Instruct the customer or operating personnel on the location of all controls and the operation of the OptiView Control Center.

Maintenance

- ✓ Review the maintenance schedule with the customer.
- ✓ Review the preventative maintenance schedule with the operating personnel and make certain that it is thoroughly understood, including the required oil filter element change after the first 200 hours of operation.
- ✓ Start-up is an excellent time to log baseline data from vibration analysis, oil analysis and eddy current testing.

SECTION 3 – OPERATION

BASIC DESCRIPTION

The YORK YR Chiller package uses a refrigerant-flooded evaporator and a liquid-cooled condenser. The compressor is a heavy-duty, industrial-rated rotary screw compressor. The YR package consists of five major components – Driveline, Oil Separator, Condenser, Evaporator and OptiView™ Control Center.

COMPONENTS

Driveline

The driveline is made up of the compressor and a 2-pole industrial induction hermetic motor. The motor is mounted to the compressor which eliminates the necessity to align the motor and compressor.

The compressor is a positive displacement, variable volume, direct drive, twin helical rotary screw compressor. The male rotor is a direct drive by the motor; the female rotor is an idler that is driven by the male rotor. The rotors do not touch each other or the compressor housing. The rotors are separated by a hydraulic oil seal, which prevents high pressure gas from leaking into low pressure areas.

Evaporator pressure gas is drawn into the compressor and compressed by the male and female rotors as they rotate together and reduce the volume of gas.

The compressor bearings are industrial duty rated, anti-friction rolling element bearings. No sleeve bearings are used. Oil is injected into the compressor by differential pressure to lubricate the bearings, seal the rotors and remove the heat of compression. The oil that is injected into the compressor mixes with the compressed gas and is separated from the refrigerant gas in the oil separator.

A slide valve is positioned between the male and female rotors, that moves axially to match the compressor capacity to that of the evaporator refrigeration load. The slide valve is moved by differential pressure. As the slide valve moves toward the unloaded position, less suction gas is pumped through the compressor. The control panel automatically positions the slide valve to match the load requirements. The slide valve can be operated manually.

When the compressor is shut off, a spring returns the slide valve to unloaded position. The compressor starts with the slide valve in the unloaded position.

Oil Separator

The oil separator removes the oil that was injected into the compressor. The oil separator is a two stage design. Most of the oil separates by a centrifugal force in the first stage. The final stage is a coalescer element(s) that removes the fine aerosol particles of oil.

The oil separator is very efficient and removes nearly 100% of the oil. The very small amount of oil that does pass through the oil separator is returned to the compressor through an evaporator eductor.

The oil separator is also a reservoir for the oil. A temperature controlled immersion heater is installed in the oil reservoir.

Condenser

Oil free refrigerant gas leaving the oil separator flows into the condenser. Water flowing through the condenser tubes removes the evaporator heat load, the heat of compression and condenses the refrigerant gas into refrigerant liquid.

The liquid refrigerant then flows through the integral liquid sub-evaporator located in the bottom of the condenser. The sub-cooled liquid refrigerant flows into the evaporator by differential pressure.

Evaporator

Condensing pressure refrigerant flows out of the liquid sub-evaporator into the liquid line where the liquid refrigerant is metered into the evaporator by a variable orifice. The liquid refrigerant begins to flash (and cool) after flowing through the orifice. The refrigerant is distributed in the bottom of the evaporator. Liquid refrigerant floods the evaporator and the heat is exchanged from the chilled liquid, flowing on the inside of the evaporator tubes, to the liquid refrigerant on the outside of the tubes.

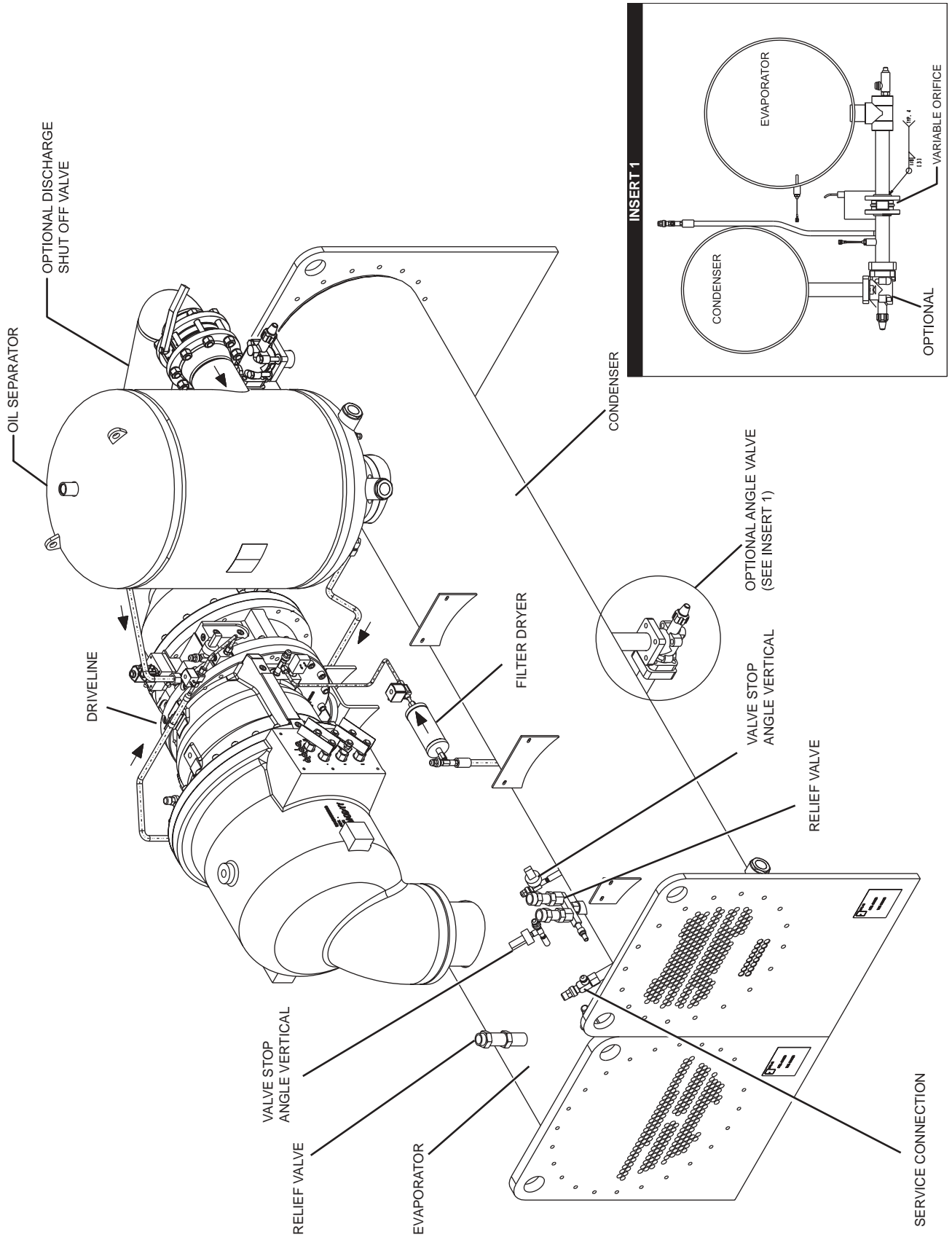

43 FIG. 15 – YR SCREW CHILLER COMPONENT LAYOUT DRAWING – DESIGN LEVEL “C”

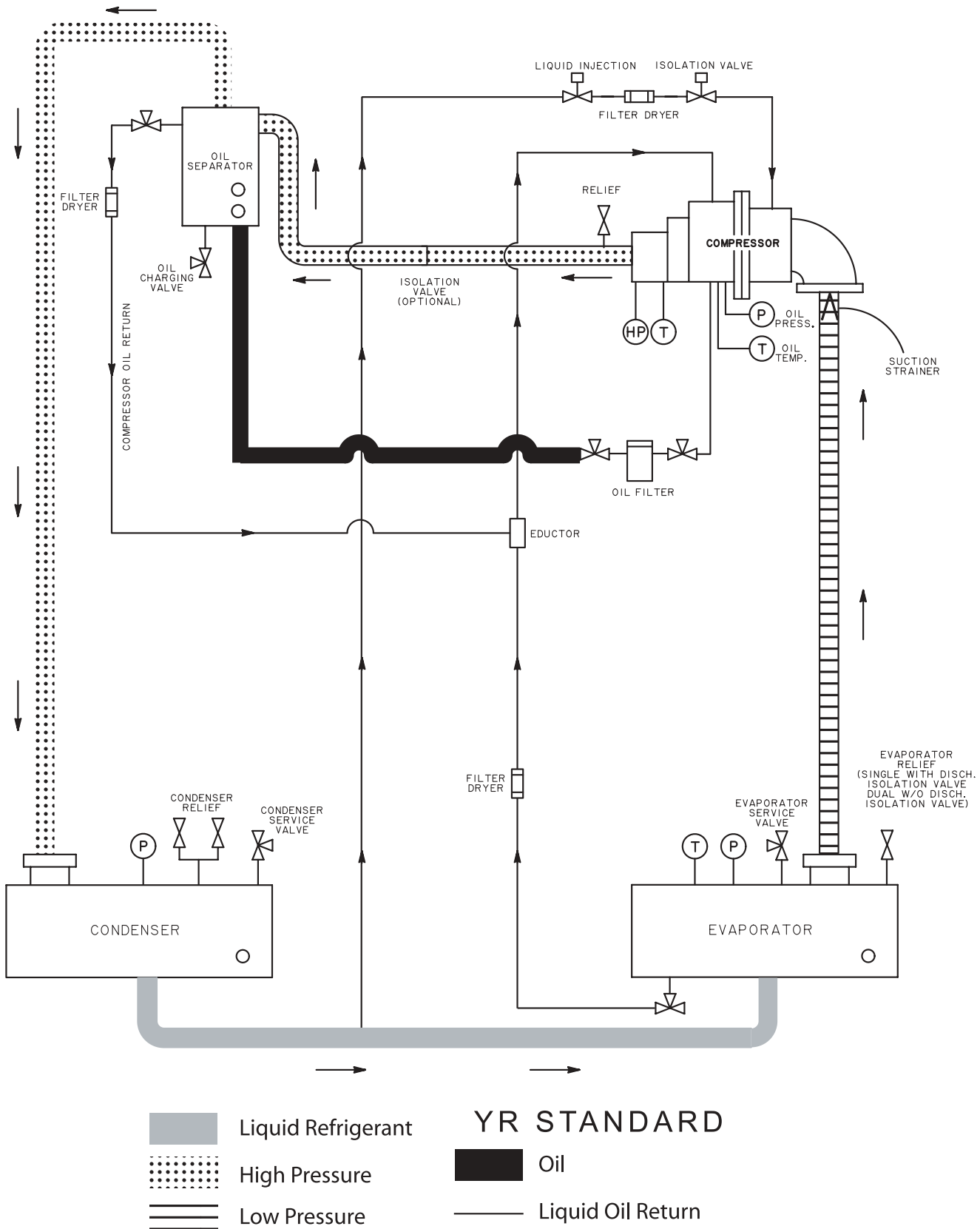

LD07962

FIG. 16 – YR SCREW CHILLER SYSTEM SCHEMATIC – DESIGN LEVEL “C”

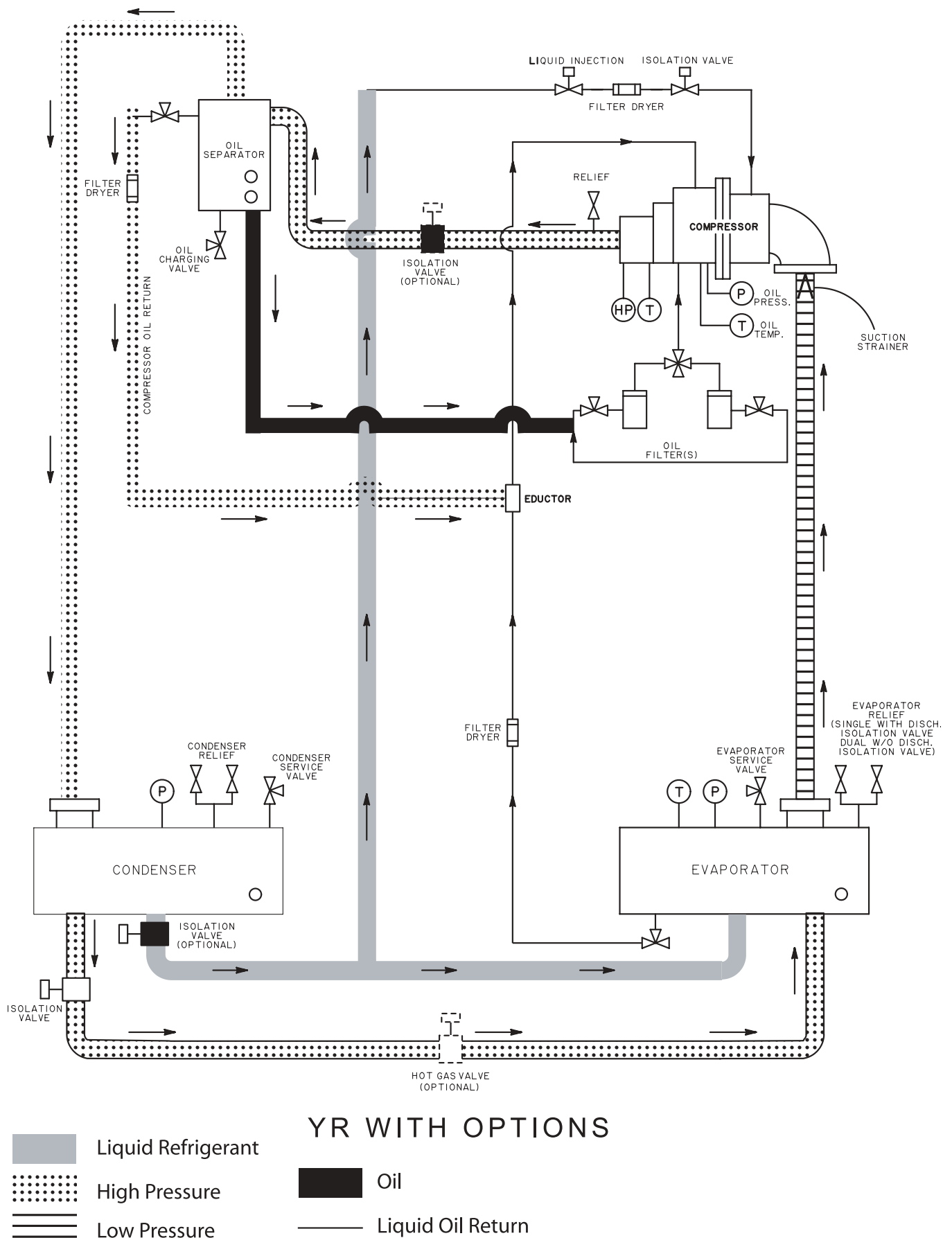

3

FIG. 16 – YR SCREW CHILLER SYSTEM SCHEMATIC – DESIGN LEVEL “C” (CONT'D)

Variable Orifice

Since liquid refrigerant is transferred from the Condenser to the Evaporator via the Condenser-Evaporator pressure differential, a large differential can create an excess refrigerant level in the evaporator. A small differential can result in insufficient level in the Evaporator. To maintain an appropriate refrigerant level in the Evaporator under all conditions, the chiller is equipped with a variable orifice. To maintain an appropriate refrigerant level in the Evaporator under all conditions, a Variable Orifice is located in the refrigerant line between the condenser and evaporator. A liquid level sensor, located in the condenser, detects the refrigerant level. The refrigerant level in the condenser is expressed as 0% (minimum) to 100% (maximum). While the chiller is shut down, an open signal is applied to the actuator, driving the orifice to the fully open position. When the chiller is started, a close signal is applied to the Orifice actuator for the duration of the “Start Sequence Initiated” period. This positions it to approximately the 75% closed position prior to starting the compressor motor, which occurs at the end of the “Start Sequence Initiated” period. To allow for actuator timing variances and assure the valve is positioned at the

75% closed position, the duration of the “Start Sequence Initiated” period is programmable.

OIL SYSTEM

Refer to the Oil Piping Schematic Drawing, Figure 16 and the Filter Driers and Oil Eductor, Figure 17.

Oil flows from the oil separator into the compressor by differential pressure. The oil flows from the oil separator through a 3 micron oil filter (or optional dual oil filters). Filtered oil then flows to a oil manifold that is located at compressor.

The oil pressure transducer is located on the compressor. The differential pressure is measured as the difference between the Oil Pressure Transducer and the Discharge Pressure Transducer, located on discharge housing of compressor. This value is compared to the limits in the control panel logic. If the oil filter differential reaches 20 PSID, a warning message is displayed by the control panel display. If the oil filter reaches 25 PSID, a safety shutdown is initiated.

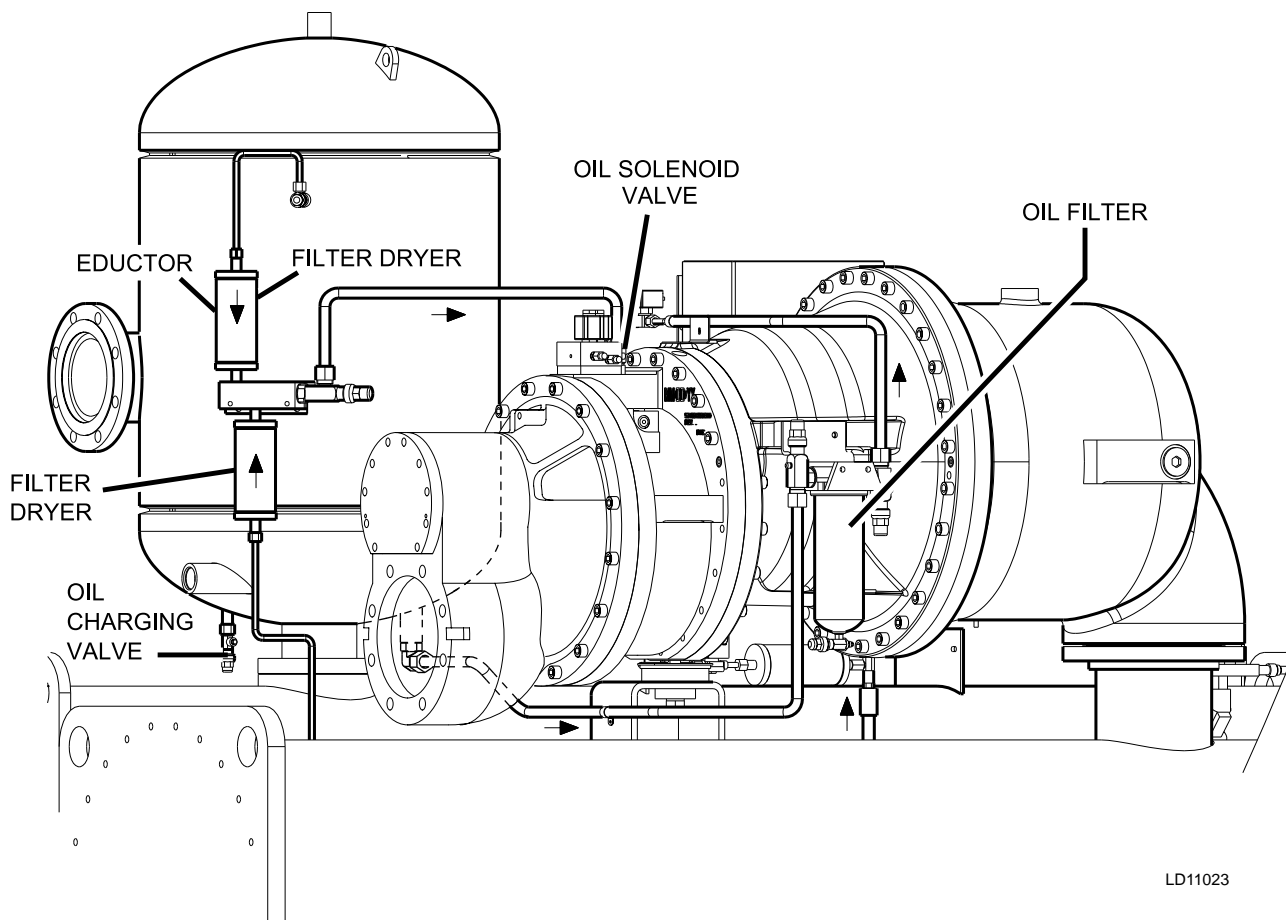

LD11023

FIG. 17 – OIL FILTER SYSTEM

The oil leaving the oil eductor manifold block flows into the compressor to lubricate the compressor bearings. All of the oil that is injected into the compressor mixes with refrigerant gas during compression. The oil and refrigerant gas is discharged into the oil separator, where it is separated and returned to the oil sump. A high discharge temperature safety is located in the discharge line, between the compressor and oil separator. This safety will initiate a safety shutdown.

Oil cooling is accomplished by liquid injection into the discharge of the compressor.

Oil is separated from the refrigerant gas in the oil separator in a two step process.

The second and final stage of oil separation is achieved in the oil coalescing element section of the oil separator. The oil mixed with the refrigerant entering the coalescer element is a very fine aerosol mist about the size of cigarette smoke particles. These small aerosol mist particles wet the coalescer element media and form larger oil droplets which fall by gravity to the bottom of the coalescer element section. The oil collected in the coalescer section is drained from the oil separator with a small amount of refrigerant gas. This provides the high pressure “gas drive” for the eductors to return oil from the evaporator. Refer to section titled “Oil Eductor Circuit,” in next column.

Two sight glasses are provided in the oil separator for monitoring the oil level and verifying performance of the coalescer element. Liquid oil should be visible in the top glass of the oil separator when the chiller is off. During operation, oil may be higher or lower due to system load and operating conditions.

An oil drain and charging valve is located on the bottom of the oil separator. A flare connection is provided for ease of connecting a hose to quickly drain used oil into a EPA approved recovery cylinder or tank. Oil can be added into the oil reservoir with the chiller in service.



Do not add oil. YORK YR Chiller packages are pre-charged with the correct amount of YORK oil during functional testing after manufacture. Refer to Table 11, YORK Oil Types, in the Maintenance Section.

Oil loss is most often the result of operating conditions at loads under 10% of the chillers rated capacity and with condensing water that is too cold for load and operating condition.

YORK INTERNATIONAL

The oil is not “lost” but has migrated into the refrigerant charge and is most likely in the evaporator. Excessive amounts of oil in the evaporator will result in operational problems.

Oil management problems can result if the compressor discharge superheat drops below 12°F. Compressor discharge superheat is the difference between the compressor discharge temperature and the saturated condenser temperature. Compressor discharge superheat is used in conjunction with the evaporator approach to determine the most efficient refrigerant charge.



Should the control panel display EXCESS CHARGE WARNING this is most likely the result of excessive amounts of oil in the evaporator. Excess amounts of oil in the refrigerant will cause foaming. The oil foam carries liquid refrigerant into the compressor. This results in lowering the compressor discharge superheat to low levels. If the compressor discharge superheat falls to within 10°F (69°C) of the saturated condensing temperature the control panel will display EXCESS CHARGE WARNING. Compressor loading will be inhibited while the EXCESS CHARGE WARNING is displayed. The inhibit loading will remain in effect until the compressor discharge superheat increases to 15°F (69°C).

OIL EDUCTOR CIRCUIT

An oil eductor circuit is provided to properly manage the amount of oil in the refrigerant charge. A small amount of oil is normal in the refrigerant charge and will be found in the evaporator. If not properly managed the oil will accumulate and have adverse consequences regarding chiller performance.

The oil eductor circuit consists of oil filter drier, eductors, and interconnecting piping. Refer to Figure 17.

The eductors operate using the “jet pump” principle. Discharge pressure gas and oil flows through a filter dryer located at the oil separator. YR Chillers are supplied with a variable orifice arrangement. The reduced

pressure (pumping action) is created by the velocity of the discharge pressure gas and oil flowing through the orifice and nozzle. This creates a reduced pressure area that allows the oil-rich refrigerant and oil to flow from the evaporator into the compressor.

Oil-rich refrigerant flows into the eductor block through the filter drier from the evaporator. The oil rich refrigerant mixes with the discharge pressure gas and flows into the compressor suction line.

The filter driers should be changed annually or when excessive amount of oil is indicated in the refrigerant charge.

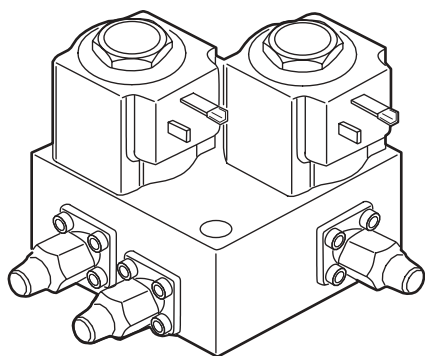

LD09033

FIG. 18 – OIL SOLENOID VALVE ASSEMBLY

LIQUID REFRIGERANT CIRCUIT

Liquid refrigerant flows from the condenser into the evaporator by differential pressure. Sub-cooled liquid refrigerant flows out of the condenser into the liquid line. A variable metering orifice is installed in the liquid line to control the rate liquid refrigerant flows into the evaporator (see figure 19). A liquid refrigerant-charging valve is piped into the liquid line between the evaporator and the metering orifice. A 3/4 inch male flare connection is provided for connecting hoses or transfer lines.

TABLE 7 – VARIABLE ORIFICE PRESSURE DIFFERENTIAL SETPOINTS

REFRIGERANT	DIFFERENTIAL PRESSURE RANGE
R-134A	15 - 110 PSID

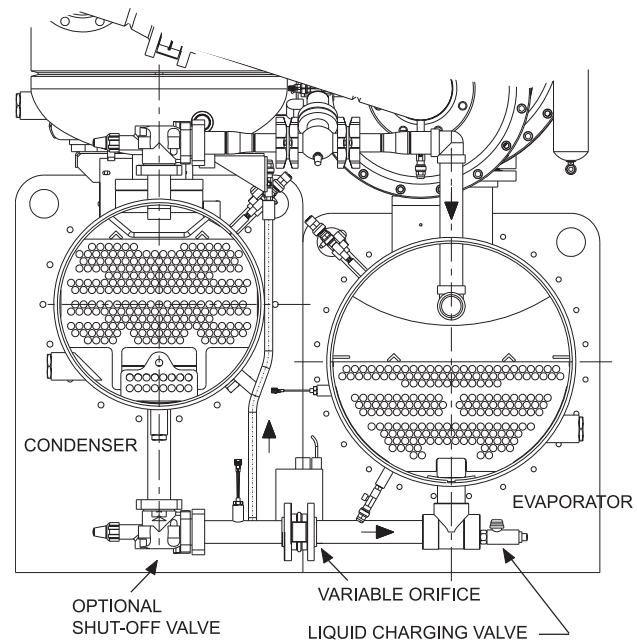

FIG. 19 – VARIABLE ORIFICE

CAPACITY CONTROL

Capacity control is accomplished by using differential gas pressure to move the slide valve. As the slide valve is moved axially between the compressor rotors the volume of gas pumped by the compressor is changed to match the system requirements.

Leaving evaporator fluid temperature is continuously monitored by the microprocessor. The Leaving Evaporator fluid temperature is compared to the Leaving Evaporator Fluid Setpoint. When the leaving evaporator fluid temperature is beyond the range of the set point value a signal is sent to the relay output board. A signal is sent from the relay output board to energize the control block valve directional solenoid valves.

Manual isolation valves are incorporated into the capacity control plate to isolate the directional valve for service. Remove the caps to gain access to the service valve stem. Use a refrigeration service valve wrench to close or open the valves.

NEED FOR MAINTENANCE OR SERVICE

If the system is malfunctioning in any manner, or the unit is stopped by one of the safety controls, please call the nearest YORK District Office. Failure to report constant troubles could damage the unit and increase the cost of repairs considerably.

NORMAL AND SAFETY SHUTDOWN AND REPAIRS

Normal and safety system shutdowns have been built into the unit to protect it from damage during certain operating conditions. Therefore, it should be understood that at certain pressures and temperatures the system will be stopped automatically by controls that respond to high temperatures, low temperatures, or low and high pressures, etc.

SAFETY SHUTDOWNS

- Evaporator – Low Pressure
- Evaporator – Low Pressure – Smart Freeze
- Evaporator – Transducer or Leaving Liquid Probe
- Evaporator – Transducer or Temperature Sensor
- Condenser – High Pressure Contacts Open
- Condenser – High Pressure
- Condenser – Pressure Transducer Out of Range
- Auxiliary Safety – Contacts Closed
- Discharge – High Pressure
- Discharge – High Temperature
- Discharge – Low Temperature
- Oil – High Temperature
- Oil – Low Differential Pressure
- Oil or Condenser Transducer Error
- Oil – Clogged Filter
- Oil – High Pressure
- Control Panel – Power Failure
- Motor or Starter – Current Imbalance
- Motor or Starter – Incorrect Compressor Rotation Detected
- Motor – High Motor Winding Temperature

Mod “B” Solid State Starter

- LCSSS Shutdown – Requesting Fault Data
- LCSSS – High Instantaneous Current
- LCSSS – High Phase Heatsink Temperature Running
- LCSSS – 105% Motor Current Overload
- LCSSS – Phase Shorted SCR

- LCSSS – Open SCR
- LCSSS Phase Rotation

CYCLING SHUTDOWNS

- Multi-Unit Cycling – Contacts Open
- System Cycling – Contacts Open
- Control Panel – Power Failure
- Leaving Chilled Liquid – Low Temperature
- Leaving Chilled Liquid – Flow Switch Open
- Condenser – Flow Switch Open
- Motor Controller – Contacts Open
- Motor Controller – Loss of Current \ Power Fault
- Control Panel – Schedule

Mod “B” Solid State Starter

- LCSSS – Initialization Failed
- LCSSS – Serial Communications
- LCSSS Shutdown – Requesting Fault Data
- LCSSS – Stop Contacts Open
- LCSSS – Power Fault
- LCSSS – Low Phase Temperature Sensor
- LCSSS – Run Signal
- LCSSS – Invalid Current Scale Selection
- LCSSS – Phase Locked Loop
- LCSSS – Low Supply Line Voltage
- LCSSS – High Supply Line Voltage
- LCSSS – Logic Board Processor
- LCSSS – Logic Board Power Supply
- LCSSS – Phase Loss

STOPPING THE SYSTEM

The OptiView™ Control Center can be programmed to start and stop automatically (maximum, once each day) whenever desired.

1. Push the COMPRESSOR “STOP/RESET” switch. The Control Center Display will show:

SYSTEM LOCKOUT DELAY

This prevents compressor restart until system equalization is achieved.

2. Stop the chilled water pump (if not wired into the Control Center, in which case it will shut off automatically).
3. Open the switch to the cooling tower fan motors, if used.
4. The compressor sump oil heater (thermostatically controlled) is energized when the unit is stopped.

PROLONGED SHUTDOWN

If the chiller is to be shut down for an extended period of time (for example, over the winter season), the following paragraphs outline the procedure to be followed.

1. During long idle periods, the tightness of the system should be checked periodically.
2. If freezing temperatures are encountered while the system is idle, carefully drain the cooling water from the cooling tower, condenser, condenser pump, and the chilled-water system chilled-water pump and coils.

Open the drains on the evaporator and condenser liquid heads to assure complete drainage. (If Solid State Starter, drain water from starter cooling loop.)

3. Open the main disconnect switches to the compressor motor, condenser water pump and the chilled water pump. Open the 115 volt circuit to the Control Center.

START- UP AFTER PROLONGED SHUTDOWN

1. When putting the system into operation after prolonged shutdown (such as during the winter), remove all oil from the separator. Install a new filter element and charge separator with fresh oil. Energize the 115 volt circuit to the control center to energize the separator sump oil heater for at least 12 hours.
2. If the water systems were drained, fill the condenser water circuit and chilled liquid circuit.

SECTION 4 – OPERATING INSPECTIONS

GENERAL

By following a regular inspection using the display readings of the OptiView Control Center, and maintenance procedure, the operator will avoid serious operating difficulty. The following list of inspections and procedures should be used as a guide.

Daily

1. Check OptiView Control Center displays.
2. If the compressor is in operation, check the bearing oil pressure. Also check the oil level in the oil reservoir. Drain or add oil as necessary.
3. Check entering and leaving condenser water pressure and temperatures for comparison with job design conditions.
4. Check the entering and leaving chilled liquid temperatures and evaporator pressure for comparison with job design conditions.
5. Check the condenser saturation temperature (based upon condenser pressure sensed by the condenser transducer).
6. Check the compressor discharge temperature. During normal operation discharge temperature should not exceed 212°F (100°C).
7. Check the compressor motor voltage and current (amps) at E-M starter on the Control Center display for Solid State Starter units.
8. Check for any signs of dirty or fouled condenser tubes. (The temperature difference between water leaving condenser and liquid refrigerant leaving the condenser should not exceed the difference recorded for a new unit by more than 4°F (-16°C).
9. Verify proper water treatment.
10. Press the “**STATUS**” key whenever the display indicates so. This allows any warning messages to be displayed.

Weekly

1. Check the Refrigerant charge.

Quarterly

1. Perform chemical analysis of oil.

Semi-Annually (or more often as required)

1. Change and inspect compressor oil filter element.
2. Oil return system
 - a. Clean oil filter.
 - b. Check operational of eductor for foreign particles.
3. Check controls and safety cutouts.

Annually (more often if necessary)

1. Drain and replace the oil in the separator oil sump.
2. Evaporator and Condenser:
 - a. Inspect and clean water strainers.
 - b. Inspect and clean tubes as required.
 - c. Inspect end sheets.
3. Inspect and service electrical components as necessary.
4. Perform chemical analysis of system.

SECTION 5 – MAINTENANCE

GENERAL

The maintenance requirements for YR Chillers is shown below. The procedure is given in the left- hand column and the frequency required is marked with an “X” shown in the right-hand columns. Refer to the note at the bottom of the form to maintain warranty validation.

TABLE 8 – OPERATION / INSPECTION / MAINTENANCE REQUIREMENTS FOR YORK YR CHILLERS

PROCEDURE	DAILY	WEEKLY	MONTHLY	YEARLY
Record operating conditions (on applicable Log Form)	X			
Check oil levels	X			
Check refrigerant levels		X		
Check oil return system operation			X	
Check operation of motor starter			X	
Check oil heater operation			X	
Check three-phase voltage and current balance			X	
Verify proper operation/setting/calibration of safety controls ¹			X	
Verify condenser and evaporator water flows			X	
Leak check and repair leaks as needed ¹			X	
Check and tighten all electrical connections				X
Megohm motor windings				X
Replace oil filter and oil return filter/driers				X
Clean or backflush heat exchanger (SSS Applications)				X
Replace coolant (After cleaning Hxer , SSS Applications)				X
Replace or clean starter air filters if applicable				X ²
Perform oil analysis on compressor lube oil ¹				X
Perform refrigeration analysis ¹				X
Perform vibration analysis				X
Perform Eddy current testing and inspect tubes ³				X
Clean tubes				X ²

For operating and maintenance requirements listed above, refer to appropriate service literature, or contact your local YORK Service Office.

¹ This procedure must be performed at the specified time interval by an Industry Certified Technician who has been trained and qualified to work on this type of YORK equipment .A record of this procedure being successfully carried out must be maintained on file by the equipment owner should proof of adequate maintenance be required at a later date for warranty validation purposes.

² More frequent service may be required depending upon local operating conditions.

³ More frequent service may be required depending upon water quality.

TABLE 9 – MAINTENANCE SCHEDULE

MAINTENANCE	HOURS OF OPERATION (MAXIMUM x 1,000)										
	2	5	10	20	30	40	50	60	70	80	90
CHANGE OIL*		X			X			X			X
CHANGE FILTER, OIL	X	X	X	X	X	X	X	X	X	X	X
OIL ANALYSIS	X	X	X	X	X	X	X	X	X	X	X
VIBRATION ANALYSIS	X		X		X		X		X		X

* Or as required, as indicated by oil analysis.

COMPRESSOR OIL

Yearly oil analysis is recommended to verify the continued use of the compressor oil.



It is very important to take the oil sample after the oil filter. The oil sample should not be left open to the atmosphere for more than 15 minutes since it will absorb moisture from the atmosphere and may yield erroneous results.

Compressor oil should be changed when the oil analysis indicates the oil has moisture and acid numbers are in excess of the limits set in Table 10.

TABLE 10 – COMPRESSOR OIL LIMITS

YORK OIL TYPE	MOISTURE CONTENT (by Karl Fisher) ppm	TAN (Total Acid Number) mgKOH/ml
H	LESS THAN 300 PPM	LESS THAN 0.5

The YORK YR Chiller Compressors use rolling element bearings (ball and roller bearings); no sleeve bearings are used. Oil analysis that include metals may cause confusion when the results are compared to other equipment that utilize different bearing types. Iron and copper are examples of metals, which will appear in oil analysis that include metals. Other metals that may appear are Titanium, Zinc, Lead, Tin and Silicon. These metals should be ignored and are acceptable in quantities of less than 100 ppm. If an oil analysis should indicate high levels of Iron (more than 300 ppm) combined with Chromium and Nickel (more than 50 ppm), consult your local YORK Service Office – this could indicate bearing damage and wear.

Changing Compressor Oil

Compressor oil is changed by draining oil from the oil separator into a refrigerant recovery container. The oil separator is under positive pressure at ambient temperatures. Connect one end of a refrigeration charging hose to the service valve located at the bottom of the oil separator; connect the other end to an approved refrigerant recovery cylinder. Open the valve and drain the oil from the oil separator.

CHARGING UNIT WITH OIL

The Oil Charge

YORK oil types approved for YR Chillers and the quantity of oil required is listed in Table 11.

TABLE 11 – YORK OIL TYPE FOR R-134a

COMP. SIZE	OIL TYPE	SYSTEM QUANTITY (GAL)
T0	H	9
T1	H	9
T2	H	15
T3	H	15

Oil Level

The YR chiller does not have an oil pump. System oil flow is dependant on the pressure differential between the condenser and evaporator. Therefore, the oil flow rate, and oil level in the separator will vary as the system pressures and slide valve position change. It is normal for the oil level to be at the bottom of the lower sight glass or near the top of the upper sight glass located on the separator, depending on conditions. Oil should NOT be added unless the oil level cannot be seen in the lower sight glass. Oil also should NOT be removed unless the oil level is above the upper sight glass. The following paragraphs outline procedures to be followed:

Start-up

1. *Oil level cannot be seen in either sight glass on oil separator:*

For chillers shipped with a factory charge of oil and refrigerant and no oil level is obvious at start-up, a qualified technician should add only enough oil to create a visible level in the bottom of the lower sight glass. Start the chiller and run a load condition greater than 65% full load amps [FLA] but less than 80% FLA for a minimum of 1 hour and observe the oil level. The oil level should become visible in either the bottom or top sight glass depending on conditions. A qualified technician should then remove the approximate amount added to start the chiller.

2. *Oil level above the upper sight glass:*

Conditions can exist where the evaporator pressure is higher than the condenser pressure. This occurs when the evaporator (or chilled) water loop

is warmer than the condenser (or cooling tower) water loop. This can cause refrigerant in the oil separator to condense, creating a liquid level (oil and refrigerant mixture) that exceeds the top of the upper sight glass. When the chiller motor is not running, a qualified technician should confirm that the oil heater is in proper working condition and is energized. If it is the first startup for the cooling season, the technician should confirm the oil heater has been energized for at least 24 hours prior to start up. During start-up, the chiller should be manually unloaded until a discharge superheat temperature (displayed on the "COMPRESSOR SCREEN" of the OptiView control center) of 18°F (-8°C) or greater is maintained and liquid level drops below the top of the upper sight glass on the oil separator. The chiller should continue to be held in a "part-load" operation until the foaming in the oil separator is minimized. The chiller can then be returned to "automated" slide valve position or "load control" to meet the cooling load requirements.

Operation:

1. *Oil should be visible in both sight glasses of the oil separator (oil level above the upper sight glass):*
If the chiller operates in a low discharge superheat

(refer to the *Troubleshooting* Section in this manual) condition for an extended period of time refrigerant can again condense in the oil separator. The chiller should be unloaded and held in a slide valve position that allows the discharge superheat to increase above 18°F (-8°C). The chiller should continue to be held in a slide valve position until the level drops below the top of the upper sight glass and foaming is minimized. The chiller can then be loaded normally as the building/process load requires.

2. *Oil level cannot be seen in either sight glass on the oil separator (oil level is below lower sight glass):*

If no oil level is in either sight glass (oil level below lower sight glass) a problem may exist with the oil return system. A qualified technician should add only enough oil to create a visible level in the bottom of the lower sight glass. Start the chiller and run a load condition greater than 65% full load amps [FLA] but less than 80% FLA for a minimum of 1 hour and observe the oil level. The oil level should become visible in either the bottom or top sight glass depending on conditions. A qualified technician should then remove the approximate amount added to start the chiller. Refer to the *Troubleshooting* Section in this manual.

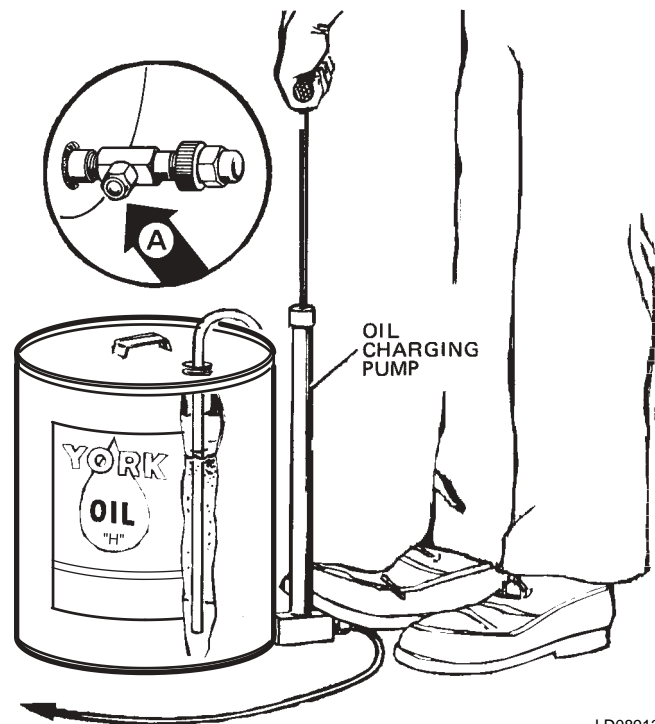
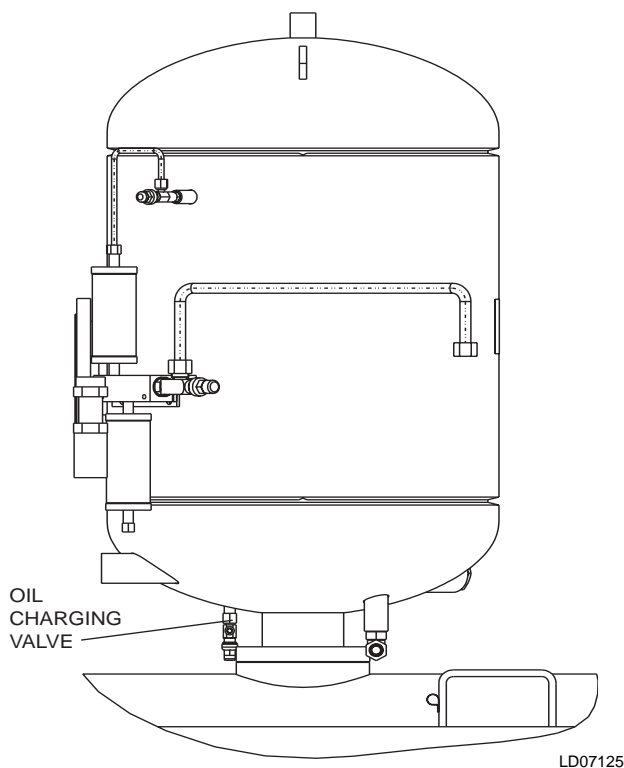
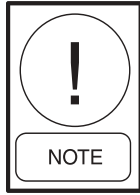

FIG. 20 – CHARGING OIL

Oil Charging Procedure



YORK H Oil is used in T0 through T3 units.

The oil should be charged into the oil separator using the YORK Oil Charging Pump – YORK Part No. 070-10654. To charge oil, proceed as follows:

1. The unit should be shut down.

Note: If charging oil to restore the correct level – the unit may be kept in operation.

2. Immerse the suction connection of the oil charging pump in a clean container of new oil and connect the pump discharge connection to the oil charging valve. Do not tighten the connection at the charging valve until after the air is forced out by pumping a few strokes of the oil pump. This fills the lines with oil and prevents air from being pumped into the system.
3. Open the oil charging valve and pump oil into the system until oil level in the oil separator is about midway in the upper sight glass. Then, close the charging valve and disconnect the hand oil pump. see Figure 20.

4. As soon as oil charging is complete, close the power supply to the starter to energize the oil heater. This will keep the concentration of refrigerant in the oil to a minimum.
5. The immersion oil heater will maintain the oil temperature between 105°F (40°C) and 115°F (46°C).

OIL TEMPERATURE CONTROL

Automatic oil temperature control is accomplished by liquid being injected into the compressor / motor assembly. A solenoid valve will be opened when the discharge temperature increases to 160°F (71°C).

OIL FILTER

A single oil filter is provided as standard equipment and dual oil filter arrangements are available as optional equipment. The oil filter(s) are a replaceable 3 micron cartridge type oil filter. Use only YORK approved oil filter elements. See Figure 21.

The oil filter element should be changed after the first 200 hours of operation and then as necessary thereafter. Always replace the oil filter element and O-ring on a yearly maintenance schedule.

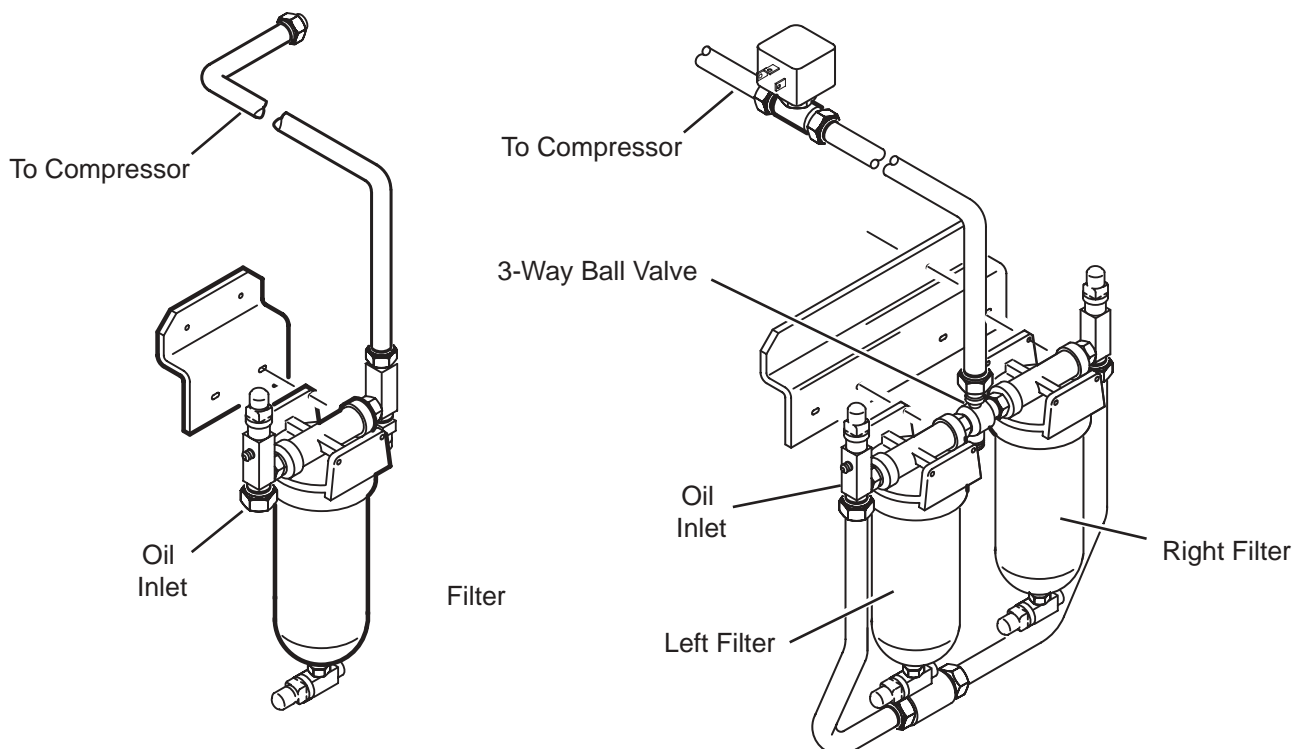

FIG. 21 – OIL FILTERS

The YORK control panel will automatically display the message “DIRTY OIL FILTER” when the differential pressure reaches 15 PSID across the oil filter. A safety shutdown will be initiated if the oil pressure differential pressure reaches 25 PSID. The control panel will display the message “CLOGGED OIL FILTER”

OIL FILTER REPLACEMENT

Single Oil Filter

The chiller must be OFF. Turn the rocker switch to the OFF position; turn the circuit breaker to the OFF position to prevent the chiller from being accidentally started.

1. Close the hand isolation valves on the inlet and outlet oil lines going to and from the oil filter.
2. Relieve the refrigerant pressure and oil in the oil filter and the oil lines through the pressure access port fitting, located on the top of the filter housing. Connect a refrigeration pressure hose to the pressure access port and drain the oil and refrigerant into a suitable refrigerant recovery container.
3. Position a container to collect the oil (less than 2 quarts, 1.9 liters). Loosen and remove the drain nut at the bottom of the oil filter housing; drain the oil into the container.
4. Unscrew the oil filter bowl locking nut.
5. Remove the oil filter element.
6. Install a new element.
7. Install a new O-ring on the top of the oil filter bowl.
8. Tighten the oil filter bowl locking nut.
9. Open the hand isolation valves.
10. The chiller is ready to be restarted.

Dual Oil Filters (Optional)

The dual oil filter option allows one oil filter to be isolated and changed with the chiller in operation.

1. Isolate the left hand filter by turning the valve stem parallel with the valve body. 90° counter clockwise. Refer to Figure 22.

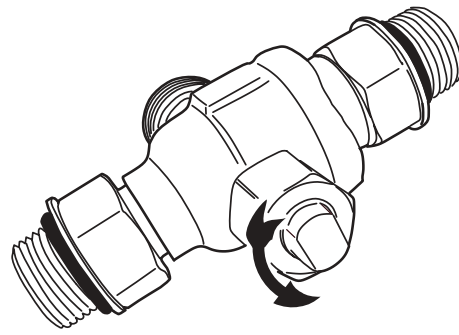

FIG. 22 – DUAL OIL FILTER ISOLATION VALVE

2. Isolate the right hand filter by turning the valve stem 1/4 turn clockwise.



Do not force the valve stem past the stop. Damage to the Isolation Valve will occur.

FILTER DRIER REPLACEMENT

The filter driers should be changed annually or when excessive amount of oil is indicated in the refrigerant charge.

When the filter driers require changing the chiller must be shut off.

1. Close the service isolation valves identified in schematic drawing, Figure 16.
2. Carefully remove the insulation on the filter driers located on the eductor block.
3. Relieve the pressure from the circuit using the pressure access fitting located on the side of the eductor block. Connect a refrigeration pressure hose to the pressure access port and drain the oil and refrigerant into a suitable refrigerant recovery container.
4. Loosen the Rota-Lock® Nuts at each end of the filter driers. Remove the filter driers.
5. Teflon® seal washers are used to seal the filter drier connections. These washers must be replaced when the filter driers are replaced.
6. Tighten the Rota-Lock® Nuts at each end of the three filter driers to a torque of 60 ft.-lb. (81 N·m)
7. Evacuate the air from the oil filter to 500 microns PSIG.
8. Open the five hand isolation valves. The chiller is now ready to be placed back into service.

DETERMINING CORRECT REFRIGERANT CHARGE LEVEL

The refrigerant charge level is correct when the measured evaporator approach and discharge refrigerant gas superheat are within the values listed in Table 12.



IMPORTANT: *The chiller must be at design operating conditions and full load operation before the correct refrigerant charge level can be properly determined.*

Liquid refrigerant will be visible in the evaporator sight glass. The refrigerant level cannot be properly determined by viewing the liquid refrigerant level in the evaporator sight glass.

All YR Chillers shipped Form 1 are charged with the correct amount of refrigerant. Under some operating conditions the chiller may appear to be overcharged or undercharged with refrigerant. Consult with the YORK Factory prior to removing or adding refrigerant. The liquid line isolation valve may have to be partially throttled to prevent overfeeding the evaporator in some applications and under certain operating conditions.

Definitions:

Evaporator Approach = (S.E.T) - (L.E.L.T)

Discharge Superheat = (C.D.G.T) - (S.C.T)

Where:

S.E.T. = Saturated Evaporator Temperature

L.E.L.T. = Leaving Evaporator Liquid Temp.

C.D.G.T. = Compressor Discharge Gas Temp.

S.C.T. = Saturated Condensing Temperature

These values can be obtained from the OptiView Control Center. Refer to OptiView Control center Operating Instructions, Form 160.81-01.

REFRIGERANT CHARGING

Should it become necessary to add refrigerant charge to a YORK YR Chiller; add charge until the evaporator approach and refrigerant gas discharge superheat are at within the values listed in Table 12.

A charging valve is located in the liquid line below the evaporator. The size of the charging connection is $\frac{3}{4}$ inch male flare. Purge air and non-condensables from the charging hose. Only add new refrigerant, or refrigerant that has been tested and certified to meet American Refrigeration Institute Standard (ARI-700).

TABLE 12 – REFRIGERANT CHARGE LEVEL

CONDITION	R-134a REFRIGERANT
COMFORT COOLING APPLICATIONS	
EVAPORATOR APPROACH	1°F-5°F
DISCHARGE SUPERHEAT	12°F-18°F
BRINE (ICE MAKING) APPLICATIONS	
EVAPORATOR APPROACH	4°F-8°F
DISCHARGE SUPERHEAT	24°F-36°F

REFRIGERANT LEAK CHECKING

Periodic refrigerant leak checking must be part of a comprehensive maintenance program. Leak check the entire chiller using a calibrated electronic leak detector.

Use a soap solution to confirm leaks that are found using the electronic leak detector.

Check refrigerant relief valve piping and tube rolled joints as part of the comprehensive refrigerant leak checking program.

Repair leaks before adding refrigerant.

PRESSURE CONNECTIONS

All threaded pressure connections used on the YORK YR Chillers are SAE straight thread, O-ring face seal type fittings or Primore Rotalock® fittings.

The O-ring straight thread fittings and O-ring face seal fittings are designed and used in accordance with SAE J1926 and J1453. Should it become necessary to remove a fitting, the O-ring(s) should be replaced. Make certain to use only neoprene replacement O-rings. O-rings can be ordered from the local YORK Service Office.

Pipe sealant compounds are not required with SAE type O-ring fittings. The O-ring seal accomplishes the pressure sealing. Lubricate the O-ring with compressor oil prior to assembly.

All filter driers and angle shut off valves use Primore Rotalock® fittings. These fittings use a Teflon® fiber seal washer. The Teflon® fiber seal washers should be replaced each time the filter driers are changed.

CONDENSERS AND EVAPORATORS

General

Maintenance of condenser and evaporator shells is important to provide trouble free operation of the unit. The water side of the tubes in the shell must be kept clean and free from scale. Proper maintenance such as tube cleaning, and testing for leaks, is covered on the following pages.

Chemical Water Treatment

Since the mineral content of the water circulated through evaporators and condensers varies with almost every source of supply, it is possible that the water being used may corrode the tubes or deposit heat resistant scale in them.

Reliable water treatment companies are available in most larger cities to supply a water treating process which will greatly reduce the corrosive and scale forming properties of almost any type of water.

As a preventive measure against scale and corrosion and to prolong the life of evaporator and condenser tubes, a chemical analysis of the water should be made, preferably before the system is installed. A reliable water treatment company can be consulted to determine whether water treatment is necessary, and if so, to furnish the proper treatment for the particular water condition.

CLEANING EVAPORATOR AND CONDENSER TUBES

Condenser Tubes – The standard condenser tubes used in YORK YR Chillers are internally enhanced copper tubes.



If the equipment is located in an unheated area that is susceptible to freezing, the water must be drained from the condenser to prevent tube failure from freezing.

Proper condenser water treatment can eliminate or significantly reduce the formation of scale on the waterside of the condenser tubes.

Maintain a minimum condenser water flow rate through the tubes of at least 3.33 ft./sec. (1 meter/sec.). Through tube water velocity should not exceed 12 ft./sec. (3.6 meter/sec.).

Condenser tubes must be maintained to provide proper chiller operation. Condenser Approach Temperature is a useful tool to monitor the performance of the condenser. By recording and logging the Condenser Approach Temperature as part of the chiller maintenance program, this will provide a warning that the waterside condenser tubes are fouled and require cleaning.

Condenser Approach Temperature is the difference between the Condenser Leaving Water Temperature and the Saturated Condensing Temperature.

If the approach increases above 10°F (5.6°C), or during the annual condenser inspection and the tubes are observed to be fouled, the tubes will require cleaning. For condenser fluids other than water consult with the local YORK Field Service Office for the correct condenser approach.

CONDENSER WATER SIDE TUBE CLEANING PROCEDURE

Two methods are used for waterside tube cleaning to remove the scale; chemical and mechanical cleaning procedures. The composition of the scale will determine which method will be most effective to remove the scale and dirt.

Consult with the local YORK Field Service Office for a recommendation of the method(s) used in the local area.

Chemical Cleaning Procedure

Chemical cleaning is an effective method to remove scale from internally enhanced copper tubes. However, a company knowledgeable with the chemical cleaning procedure should be contracted or consulted. Follow the chemical cleaning company recommendations concerning solution cleaning strength and time duration of the cleaning process.



Serious damage to the condenser tubes will result if the chemical cleaning procedure is improperly applied.

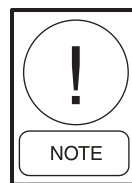

Mechanical tube cleaning must always follow a chemical cleaning procedure.

When chemical cleaning of the condenser tubes is required, it may be necessary to calculate the internal volume of the waterside condenser tubes. This information is necessary to properly mix the correct concentration of cleaning solution.

Standard materials of construction for YORK YR Chiller condensers is copper tubes and mild carbon steel water boxes.

The internal volume (waterside) of the condenser can be calculated as follows:

$$\text{Volume (in}^3\text{)} = N * L * 0.30680 \text{ in}^3/\text{in}$$

Where: N = Number of Condenser Tubes
L = Length of each Tube in inches

To convert in^3 to gallons, divide the Volume (in^3) by 231 $\text{in}^3/\text{gallon}$.

Mechanical Cleaning Procedure

1. Drain the water from the condenser.
2. Remove the water boxes from both ends of the condenser. Use proper lifting equipment when removing the water boxes. Use caution not to damage the threads on the mounting studs that are welded to the tube sheet.
3. Select a tube cleaning brush for 5/8 inch I.D copper condenser tubes. If tubes other than 5/8 inch copper are used, select a tube cleaning brush that is made for the tube size. Generally, brushes made of hard plastic or brass bristled wires are preferred for cleaning copper tubes.
4. Attach the tube cleaning brush to the end of a cleaning machine or cleaning rod.
5. Flush the condenser with clean water to remove the debris.
6. Replace the water box gasket with a new gasket and reassemble the water boxes onto the condenser.

EVAPORATOR TUBES

The standard evaporator tubes used in YORK YR Chillers are internally enhanced copper tubes.



If the equipment is located in an unheated area that is susceptible to freezing, the water must be drained from the evaporator to prevent tube damage from freezing.

Maintain evaporator water or brine flow rates through the evaporator tubes that the chiller was designed for. Refer to the engineering data on the sales order form for the correct flow rates.

Generally, the water or brine that is circulated through the evaporator is part of closed loop circuit that is treated with chemicals to prevent the formation of scale and debris.

Evaporator

It is difficult to determine by any particular test whether possible lack of performance of the water evaporator is due to fouled tubes alone or due to a combination of troubles. Trouble which may be due to fouled tubes is indicated when, over a period of time, the cooling capacity decreases and the split (temperature difference between water leaving the evaporator and the refrigerant temperature in the evaporator) increases. A gradual drop-off in cooling capacity can also be caused by a gradual leak of refrigerant from the system or by a combination of fouled tubes and shortage of refrigerant charge. An excessive quantity of oil in the evaporator can also contribute to erratic performance.

If cleaning of the evaporator tubes is required, follow the condenser cleaning procedure.

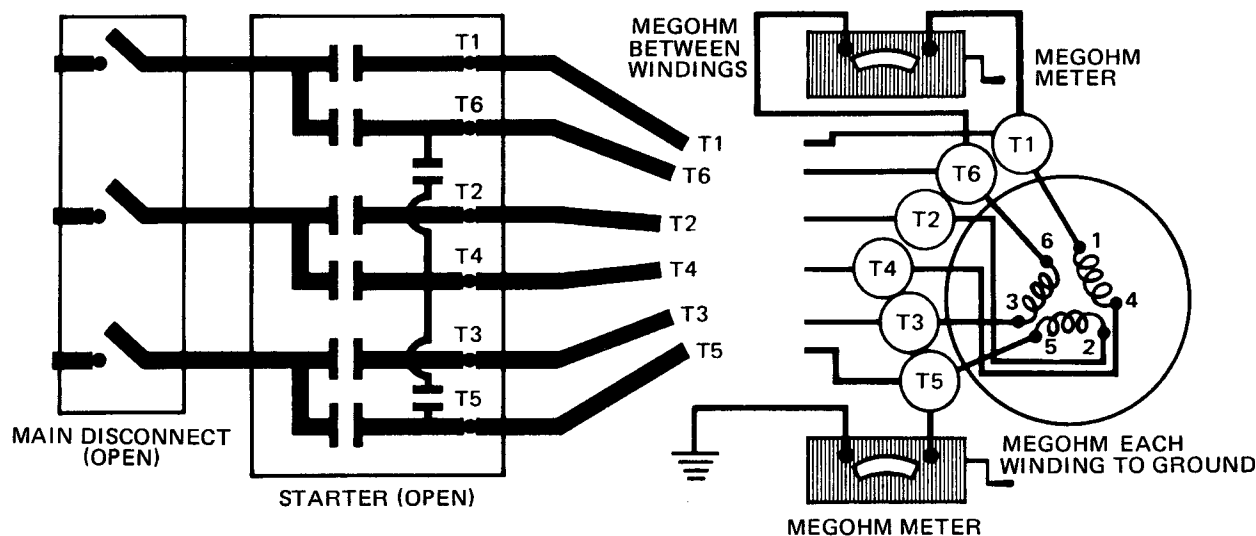

FIG. 23 – DIAGRAM, MEGOHM MOTOR WINDINGS

LD00475

MEGOHM THE MOTOR

Make certain that the motor disconnect switch (circuit breaker) is in the open position. Megohm the motor as follows:

1. Use a megohm meter to verify the minimum motor and wiring insulation resistance. Megohm between phases and each phase to ground. Refer to Figure 23, Diagram, Megohm Motor Windings.
2. If insulation resistance values fall to the left of the curve, remove external leads from the motor and repeat test.



Motor is to be megged with the starter at ambient temperature after 24 hours of idle standby.

CHECKING SYSTEM FOR LEAKS

Leak Testing During Operation

The refrigerant side of the system is carefully pressure tested and evacuated at the factory.

After the system is in operation under load, the high pressure components should be carefully leak tested with a leak detector to be sure all joints are tight.

If a leak exists, frequent purging will be required or refrigerant will be lost.

If any leaks are indicated, they must be repaired immediately. Usually, leaks can be stopped by tightening flare nuts or flange bolts. However, if it is necessary to repair a welded joint, the refrigerant charge must be removed. (See the “*Handling Refrigerant for Dismantling and Repair*” Section of the *Maintenance* Section in this manual).

Conducting R-134a Pressure Test

With the R-134a charge removed and all known leaks repaired, the system should be charged with a small amount of R-134a mixed with dry nitrogen so that a halide torch or electronic leak detector can be used to detect any leaks too small to be found by the soap test.

To test with R-134a, proceed as follows:

1. With no pressure in the system, charge R-134a gas and dry nitrogen into the system through the charging valve to a pressure of 150 PSIG.
2. To be sure that the concentration of refrigerant has reached all parts of the system, slightly open the oil charging valve and test for the presence of refrigerant with a leak detector.
3. Test around each joint and factory weld. It is important that this test be thoroughly and carefully done, spending as much time as necessary and using a good leak detector.
4. To check for refrigerant leaks in the evaporator and condenser, open the vents in the evaporator and condenser heads and test for the presence of refrigerant. If no refrigerant is present, the tubes and tube sheets

may be considered tight. If refrigerant is detected at the vents, the heads must be removed, the leak located (by means of soap test or leak detector) and repaired.

- When absolute tightness of the system has been established, blow the mixture of nitrogen and refrigerant through the charging valve.

EVACUATION AND DEHYDRATION OF UNIT

Vacuum Dehydration

Should the chiller be opened to the atmosphere for lengthy repair or service, follow the Vacuum Dehydration Guidelines to ensure that all air, moisture and non-condensable gases are removed prior to placing the chiller into service.

Vacuum Testing

After the pressure test has been completed, the vacuum test should be conducted as follows:

- Connect a high capacity vacuum pump, with indicator, to the system charging valve as shown in Figure 24 and start the pump. (See “Vacuum Dehydration”.)
- Open wide all system valves, including the purge and gauge valves. Be sure all valves to the atmosphere are closed.
- Operate the vacuum pump in accordance with VACUUM DEHYDRATION until a wet bulb temperature of +32°F (0°C) or a pressure of 5 mm Hg is reached. Refer to the *Systems Pressures* Table in the *Installation* Section of this manual for corresponding values of pressure.
- To improve evacuation circulate hot water (not to exceed 125°F (52°C)) through the evaporator and condenser tubes to thoroughly dehydrate the shells. If a source of hot water is not readily available, a portable water heater should be employed. **DO NOT USE STEAM.** A suggested method is to connect a hose between the source of hot water under pressure and the evaporator head drain connection, out the evaporator vent connection, into the condenser head drain and out the condenser vent. To avoid the possibility of causing leaks, the temperature should be brought up slowly so that the tubes and shell are heated evenly.
- Close the system charging valve and the stop valve between the vacuum indicator and the vacuum pump (See Fig. 16.). Then disconnect the vacuum pump leaving the vacuum indicator in place.

- Hold the vacuum obtained in Step 3 in the system for 8 hours; the slightest rise in pressure indicates a leak or the presence of moisture, or both. If, after 8 hours the wet bulb temperature in the vacuum indicator has not risen above 40°F or a pressure of 6.3 mm Hg, the system may be considered tight.

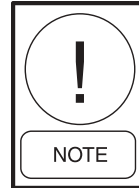

Be sure the vacuum indicator is valved off while holding the system vacuum and be sure to open the valve between the vacuum indicator and the system when checking the vacuum after the 8 hour period.

- If the vacuum does not hold for 8 hours within the limits specified in Step 6 above, the leak must be found and repaired.

To avoid the possibility of freezing liquid within the evaporator tubes when charging an evacuated system, only refrigerant vapor from the top of the drum or cylinder must be admitted to the system pressure until the system pressure is raised above the point corresponding to the freezing point of the evaporator liquid. For water, the pressure corresponding to the freezing point is 57.5 PSIG for R-134a (at sea level).

While charging, every precaution must be taken to prevent moisture laden air from entering the system. Make up a suitable charging connection from new copper tubing to fit between the system charging valve and the fitting on the charging cylinder. This connection should be as short as possible but long enough to permit sufficient flexibility for changing cylinders. The charging connection should be purged each time a full container of refrigerant is connected and changing containers should be done as quickly as possible to minimize the loss of refrigerant.

CHECKING THE REFRIGERANT CHARGE DURING UNIT SHUTDOWN

The refrigerant charge is specified for each chiller model. Charge the correct amount of refrigerant and record the level in the evaporator sight glass.

The refrigerant charge should always be checked and trimmed when the system is shut down.

The refrigerant charge level must be checked after the pressure and temperature have equalized between the condenser and evaporator. This would be expected to be 4 hours or more after the compressor and water pumps are stopped. The level should be at the center of the upper sight glass.

Charge the refrigerant in accordance with the method shown under "Refrigerant Charging." The refrigerant level should be observed and the level recorded after initial charging.

HANDLING REFRIGERANT FOR DISMANTLING AND REPAIRS

If it becomes necessary to open any part of the refrigerant system for repairs, it will be necessary to remove the charge before opening any part of the unit.

Condenser – In a condenser, trouble due to fouled tubes is usually indicated by a steady rise in head pressure, over a period of time, accompanied by a steady rise in condensing temperature, and noisy operation. These symptoms may also be due to foul gas buildup. Purging will remove the foul gas revealing the effect of fouling.

Tube Fouling

Fouling of the tubes can be due to deposits of two types as follows:

1. Rust or sludge – which finds its way into the tubes and accumulates there. This material usually does not build up on the inner tube surfaces as scale, but does interfere with the heat transfer. Rust or sludge can generally be removed from the tubes by a thorough brushing process.
2. Scale – due to mineral deposits. These deposits, even though very thin and scarcely detectable upon physical inspection, are highly resistant to heat transfer. They can be removed most effectively by circulating an acid solution through the tubes.

TUBE CLEANING PROCEDURES

Brush Cleaning of Tubes

If the tube consists of dirt and sludge, it can usually be removed by means of the brushing process. Drain the water sides of the circuit to be cleaned (cooling water or chilled water), remove the heads and thoroughly clean each tube with a soft bristle bronze or nylon brush. **DO NOT USE A STEEL BRISTLE BRUSH.** A steel brush may damage the tubes.

Improved results can be obtained by admitting water into the tube during the cleaning process. This can be done by mounting the brush on a suitable length of 1/8" pipe with a few small holes at the brush end and

connecting the other end by means of a hose to the water supply.

The tubes should always be brush cleaned before acid cleaning.

Acid Cleaning of Tubes – If the tubes are fouled with a hard scale deposit, they may require acid cleaning. It is important that before acid cleaning, the tubes be cleaned by the brushing process described above. If the relatively loose foreign material is removed before the acid cleaning, the acid solution will have less material to dissolve and flush from the tubes with the result that a more satisfactory cleaning job will be accomplished with a probable saving of time.

COMMERCIAL ACID CLEANING

In many major cities, commercial organizations now offer a specialized service of acid cleaning evaporators and condensers. If acid cleaning is required, YORK recommends the use of this type of organization. The Dow Industries Service Division of the Dow Chemical Company, Tulsa, Oklahoma, with branches in principal cities is one of the most reliable of these companies.

TESTING FOR EVAPORATOR AND CONDENSER TUBE LEAKS

Evaporator and condenser tube leaks in R-134a systems may result in refrigerant leaking into the water circuit, or water leaking into the shell depending on the pressure levels. If refrigerant is leaking into the water, it can be detected at the liquid head vents after a period of shutdown. If water is leaking into the refrigerant, frequent purging will be necessary and system capacity and efficiency will drop off sharply. If a tube is leaking and water has entered the system, the evaporator and condenser should be valved off from the rest of the water circuit and drained immediately to prevent severe rusting and corrosion. If a tube leak is indicated, the exact location of the leak may be determined as follows:

1. Allow the system to warm up until a substantial pressure is reached for testing. Dry nitrogen (pressure not to exceed 12 PSIG (83kPa)) may be admitted to the unit to increase pressure in the shell. Remove the heads and listen at each section of tubes for a hissing sound that would indicate gas leakage. This will assist in locating the section of tubes to be further investigated. If the probable location of the leaky tubes has been determined, treat that section in the following manner (if the location is not definite, all the tubes will require investigation).

- Wash off both tube heads and the ends of all tubes with water.

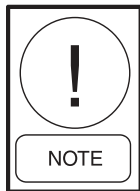

Do not use carbon tetrachloride for this purpose since its fumes give the same flame discoloration that the refrigerant does.

- With nitrogen or dry air, blow out the tubes to clear them of traces of refrigerant laden moisture from the circulation water. As soon as the tubes are clear, a cork should be driven into each end of the tube. Repeat this with all of the other tubes in the suspected section or if necessary, with all the tubes in the evaporator or condenser. Allow the evaporator or condenser to remain corked up to 12 to 24 hours before proceeding. Depending upon the amount of leakage, the corks may blow from the end of a tube, indicating the location of the leakage. If not, it will be necessary to make a very thorough test with the halide torch.
- After the tubes have been corked for 12 to 24 hours, it is recommended that two men working at both ends of the evaporator carefully test each tube – one man removing corks at one end and the other at the opposite end to remove corks and handle the test torch. Start with the top row of tubes in the section being investigated. Remove the corks at the ends of one tube simultaneously and insert the exploring tube for 5 seconds – this should be long enough to draw into the detector any refrigerant gas that might have leaked through the tube walls. A fan placed at the end of the evaporator opposite the detector will assure that any leakage will travel through the tube to the detector.
- Mark any leaking tubes for later identification.
- If any of the tube sheet joints are leaking, the leak should be indicated by the detector. If a tube sheet leak is suspected, its exact location may be found by using a soap solution. A continuous buildup of bubbles around a tube indicates a tube sheet leak.

COMPRESSOR

Maintenance for the compressor assembly consists of checking the operation of the oil return system and changing the dehydrator, checking and changing the oil, checking and changing the oil filters, checking the operation of the oil heater and observing the operation of the compressor.

Internal wearing of compressor parts could be a serious problem caused by improper lubrication, brought about by restricted oil lines, passages, or dirty oil filters. If the unit is shutting down on High Oil Temperature (HOT) or Low Oil Pressure (LOP), change the oil filter element. Examine the oil filter element for the presence of foreign material. If foreign material is noticeable and the same conditions continue to stop the unit operation after a new filter element is installed, notify the nearest YORK office to request the presence of a YORK Service representative.

VIBRATION ANALYSIS

Vibration analysis performed at yearly intervals is a useful diagnostic that can detect internal damage to rotating machinery and component parts. Contact the local York Field Office for the Vibration Analysis Service.

ELECTRICAL CONTROLS

For information covering the MicroComputer Control Center operation, refer to Form 160.81-O1.1 and Wiring Diagrams, Forms 160.81-PW2, or 160.81-PW1.

The operating points of the pressure and temperature cut outs are shown in the Wiring Diagrams. These diagrams also contain a starting and stopping sequence and timing sequence diagram.

Preventive Maintenance

It is the responsibility of the owner to provide the necessary daily, monthly and yearly maintenance requirements of the system. **IMPORTANT – If a unit failure occurs due to improper maintenance during the warranty period; YORK will not be liable for costs incurred to return the system to satisfactory operation.**

In any operating system it is most important to provide a planned maintenance and inspection of its functioning parts to keep it operating at its peak efficiency. Therefore, the following maintenance should be performed when prescribed.

Compressor

- Oil Filter – The oil filter must be changed when the oil pressure drops 30% or semiannually if not required earlier.

When the oil filter is changed, it should be inspected thoroughly for any metal particles which would in-

dicating possible bearing wear. If metal particles are found this should be brought to the attention of the nearest YORK office for their further investigation and recommendations.

2. **Oil Changing** – The oil in the compressor must be changed annually, or earlier if it becomes dark or cloudy.

Pressure Testing

The unit should be pressure tested annually. Any leaks found must be repaired immediately.

Evaporator and Condenser

The major portion of maintenance on the condenser and evaporator will deal with the maintaining of the water side of the condenser and evaporator in a clean condition.

The use of untreated water in cooling towers, closed water systems, etc. frequently results in one or more of the following:

1. Scale Formation.
2. Corrosion or Rusting.
3. Slime and Algae Formation.

It is therefore to the benefit of the user to provide for proper water treatment to provide for a longer and more economical life of the equipment. The following recommendation should be followed in determining the condition of the water side of the condenser and evaporator tubes.

1. The condenser tubes should be cleaned annually or earlier if conditions warrant. If the temperature difference between the water off the condenser and the condenser liquid temperature is more than 4° greater than the difference recorded on a new unit, it is a good indication that the condenser tubes require cleaning. They should be cleaned as instructed in the *Maintenance* section of this manual, "*Tube Cleaning Procedures*".
2. The evaporator tubes under normal circumstances will not require cleaning. If, however, the temperature difference between the refrigerant and the chilled water increases slowly over the operating season, it is an indication that the evaporator tubes may be fouling or that there may be a water bypass in the water box requiring gasket replacement.

Oil Return System

1. Clean the strainer in the oil return system semiannually or earlier if the oil return system fails to operate.
2. When the strainer is cleaned, the nozzle of the educator should be checked for any foreign particles that may be obstructing the jet.

ELECTRICAL CONTROLS

1. All electrical controls should be inspected for obvious malfunctions.
2. It is important that the factory settings of controls (operation and safety) not be changed. If the settings are changed without YORK's approval, the warranty will be jeopardized.

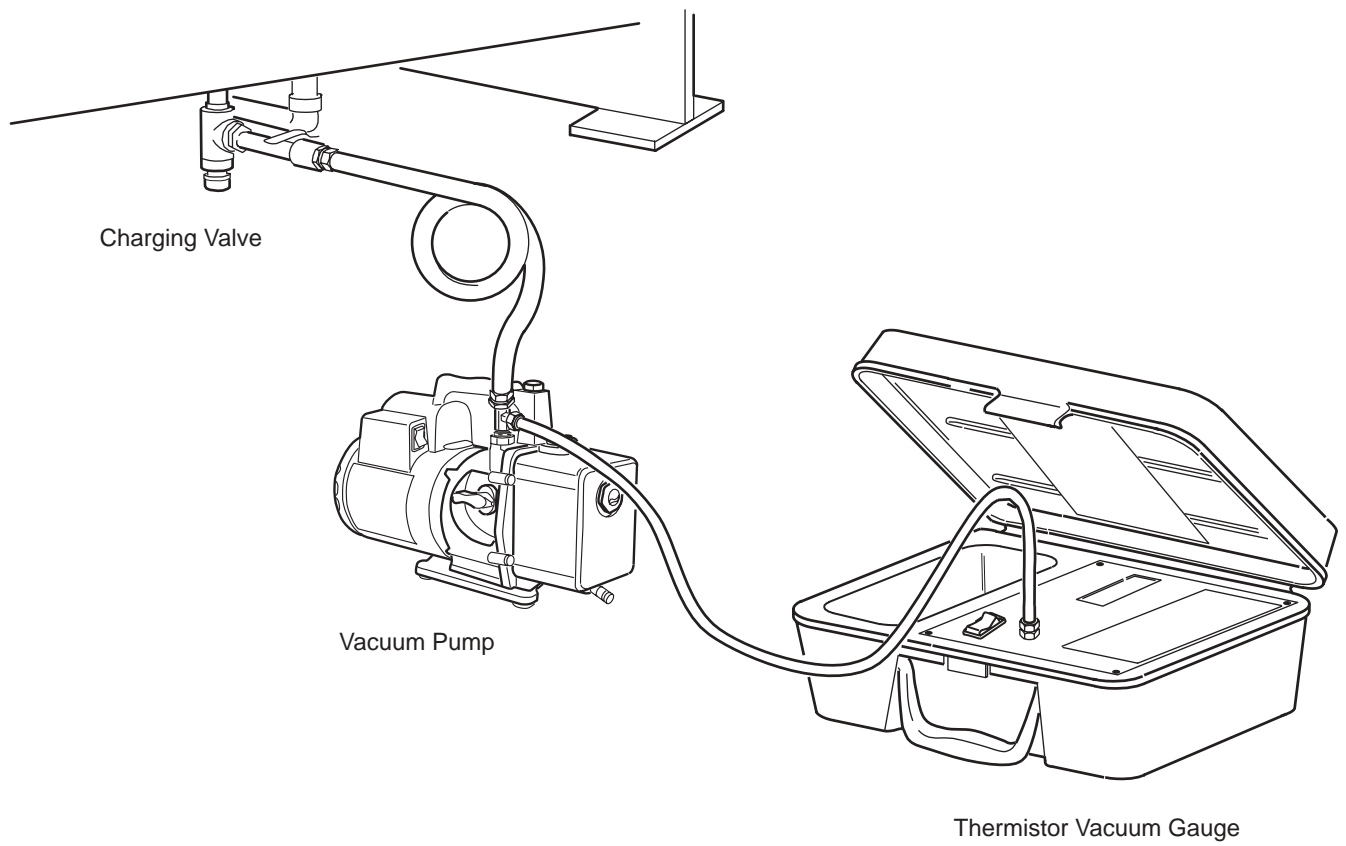

FIG. 24 – EVACUATION OF THE CHILLER

LD009186

SECTION 6 – TROUBLESHOOTING

TROUBLESHOOTING GUIDE

Successful problem solving requires an organized approach to define the problem, identify the cause, and make the proper correction. Sometimes it is possible that two relatively obvious problems combine to provide a set of symptoms that can mislead the troubleshooter. Be aware of this possibility and avoid solving the “wrong problem”.

ABNORMAL OPERATION, ANALYSIS AND CORRECTION

Four logical steps are required to analyze an operational problem effectively and make the necessary corrections:

1. Define the problem and its limits.
2. Identify all possible causes.
3. Test each cause until the source of the problem is found.
4. Make the necessary corrections.

When an operating problem develops, compare all operating information on the OPERATING DISPLAY with normal operating conditions. If an Operating Log has been maintained, the log can help determine what constitutes normal operation for the compressor unit in that particular system.

TROUBLESHOOTING THE ROTARY SCREW COMPRESSOR AND OIL SEPARATION SYSTEM

Troubleshooting the compressor is limited to identifying the probable cause. If a mechanical problem is suspected contact the Service Department, York International. DO NOT DISASSEMBLE COMPRESSOR.

TROUBLESHOOTING THE ROTARY SCREW COMPRESSOR	
SYMPTOM	PROBABLE CAUSES AND CORRECTIONS
EXCESSIVE NOISE AND VIBRATION	Bearing damage or excessive wear. Refrigerant flood back. Correct system problem. Chiller installation. Room acoustics. Piping supports.
SLIDE VALVE WILL NOT MOVE	Slide valve stuck. Capacity control block solenoid not energized. Capacity control block services valves not opened. Plugged orifices on capacity control block.
TROUBLESHOOTING THE OIL SEPARATION SYSTEM	
SYMPTOM	PROBABLE CAUSES AND CORRECTIONS
GRADUAL OIL LOSS WITH AN OIL LEVEL IN THE SEPARATOR SECTION SIGHT GLASS	Maintaining too high an oil level, lower level. Refrigerant carryover or liquid injection overfeeding, correct operation. Loss of suction superheat.

TABLE 13 – OPERATING ANALYSIS CHART

RESULTS	POSSIBLE CAUSE	REMEDY
1. SYMPTOM: ABNORMALLY HIGH DISCHARGE PRESSURE		
Temperature difference between liquid refrigerant temperature and water off condenser higher than normal.	Air in condenser.	Purge unit.
High discharge pressure.	Condenser tubes dirty or scaled.	Clean condenser tubes. Check water conditioning.
	High condenser water temperature.	Reduce condenser water inlet temperature. (Check cooling tower and water circulation.)
Temperature difference between condenser water on and water off higher than normal, with normal evaporator pressure.	Insufficient condensing water flow.	Increase the quantity of water through the condenser to proper value.
2. SYMPTOM: ABNORMALLY LOW SUCTION PRESSURE		
Temperature difference between leaving chilled water and refrigerant in evaporator greater than normal with high discharge temperature.	Insufficient charge of refrigerant.	Check for leaks and charge refrigerant into system.
	Flow orifice blocked.	Remove obstruction.
Temperature difference between leaving chilled water and refrigerant in the evaporator greater than normal with normal discharge temperature.	Evaporator tubes dirty or restricted.	Clean evaporator tubes.
Temperature of chilled water too low with low motor amperes.	Insufficient load for system capacity.	Check slide valve operation and setting of low water temperature cutout.
3. SYMPTOM: HIGH EVAPORATOR PRESSURE		
High chilled water temperature.	Slide valves fail to open.	Check the slide valve solenoid valve.
	System overload.	Be sure the vanes are loaded (without overloading the motor) until the load decreases.
4. SYMPTOM: COMPRESSOR STARTS, NORMAL OIL PRESSURE DEVELOPS, FLUCTUATES FOR SHORT WHILE, THEN COMPRESSOR STOPS ON OIL PRESSURE CUTOUT		
Oil pressure normal, fluctuates then compressor stops on Oil Pressure Cutout. Display reading LOW OIL PRESSURE	Unusual starting conditions exist, i.e., oil foaming in reservoir and piping due to lowered system pressure.	Drain the oil from the oil separator and charge new oil into the oil separator.
	Burned out oil heater.	Replace oil heater.

TABLE 13 – OPERATING ANALYSIS CHART (CONTINUED)

RESULTS	POSSIBLE CAUSE	REMEDY
5. SYMPTOM: OIL PRESSURE GRADUALLY DECREASES (Noted by Observation of Daily Log Sheets)		
Oil pressure (noted when pressing OIL PRESSURE display key) drops to 70% of oil pressure when compressor was originally started.	Oil filter is dirty.	Change oil filter.
	Extreme bearing wear.	Inspect compressor.
6. SYMPTOM: OIL RETURN SYSTEM CEASES TO RETURN AN OIL/REFRIGERANT SAMPLE		
Oil refrigerant return not functioning.	Strainer in oil return system dirty.	Replace old strainer with new.
	Jet or orifice of oil return jet clogged.	Remove jet, inspect for dirt. Remove dirt using solvent and replace.
7. SYMPTOM: SYSTEM FAILS TO DELIVER OIL PRESSURE		
No oil pressure registers when pressing OIL PRESSURE display key.	Faulty oil pressure transducer. Faulty wiring/connectors.	Replace oil pressure transducer.
8. SYMPTOM: LOW DISCHARGE SUPERHEAT WARNING MESSAGE		
Low Discharge Superheat	Over charged with refrigerant.	Adjust charge.
	Refrigerant saturated with oil.	Perform oil recovery and check oil levels.
	Variable Orifice not functioning properly.	Repair or adjust Variable Orifice.
	Refrigerant level set incorrectly.	Raise refrigerant level set point.

PRESSURE/TEMPERATURE CONVERSION TABLES

The numbers in bold-face type in the center column refer to the temperature, either in Centigrade or Fahrenheit, which is to be converted to the other scale. Converting Fahrenheit to Centigrade the equivalent temperature will be found in the left column. If converting Centigrade to Fahrenheit, the equivalent temperature will be found in the column on the right.

TEMPERATURE / PRESSURE CHART 134a SATURATION PROPERTIES (ENGLISH UNITS)	
PRESSURE PSI	HFC - 134a SATURATION TEMPERATURE DEGREES F
15*	-40
10*	-30
5*	-22
0	-15
5	-3
10	7
15	15
20	22
25	29
30	35
35	40
40	45
45	50
50	54
55	58
60	62
65	66
70	69
75	73
80	76
85	79
90	82
95	85
100	88
110	93
120	98
130	103
140	107
150	112
165	118
180	123
195	129
210	134
225	139
240	143
255	148
270	152
285	156
300	160

*in Hg. vacuum

TEMPERATURE / PRESSURE CHART 134a SATURATION PROPERTIES (SI UNITS)	
PRESSURE (kPA)	HFC - 134a SATURATION TEMPERATURE DEGREES C
25	-53
50	-40
75	-32
100	-26
125	-21
150	-17
175	-13
200	-10
225	-7
250	-4
275	-2
300	1
325	3
350	5
375	7
400	9
450	12
500	16
550	19
600	22
650	24
700	27
750	29
800	31
900	36
1000	39
1200	46
1400	52
1600	58
1800	63
2000	67
2200	72
2400	76
2600	79
2800	83
3000	86
3200	89
3400	93
3600	95

TEMPERATURE CONVERSION TABLES

The numbers in bold-face type in the center column refer to the temperature, either in Centigrade or Fahrenheit, which is to be converted to the other scale. Converting Fahrenheit to Centigrade the equivalent temperature will be found in the left column. If converting Centigrade to Fahrenheit, the equivalent temperature will be found in the column on the right.

TEMPERATURE		
°C	°C or °F	°F
-40.0	-40	-40.0
-39.4	-39	-38.2
-38.9	-38	-36.4
-38.3	-37	-34.6
-37.8	-36	-32.8
-37.2	-35	-31.0
-36.7	-34	-29.2
-36.1	-33	-27.4
-35.6	-32	-25.6
-35.0	-31	-23.8
-34.4	-30	-22.0
-33.9	-29	-20.2
-33.3	-28	-18.4
-32.8	-27	-16.6
-32.2	-26	-14.8
-31.7	-25	-13.0
-31.1	-24	-11.2
-30.6	-23	-9.4
-30.0	-22	-7.6
-29.4	-21	-5.8
-28.9	-20	-4.0
-28.3	-19	-2.2
-27.8	-18	-0.4
-27.2	-17	+1.4
-26.7	-16	+3.2
-26.1	-15	+5.0
-25.6	-14	+6.8
-25.0	-13	+8.6
-24.4	-12	+10.4
-23.9	-11	+12.2
-23.3	-10	+14.0
-22.8	-9	+15.8
-22.2	-8	+17.6
-21.7	-7	+19.4
-21.1	-6	+21.2
20.6	+23.0	
-20.0	-4	+24.8
-19.4	-3	+26.6
-18.9	-2	+28.4
-18.3	-1	+30.2
-17.8	0	+32.0
-17.2	+1	+33.8
-16.7	+2	+35.6
-16.1	+3	+37.4
-15.6	+4	+39.2
-15.0	+5	+41.0
-14.4	+6	+42.8
-13.9	+7	+44.6
-13.3	+8	+46.4
-12.8	+9	+48.2
-12.2	+10	+50.0
-11.7	+11	+51.8
-11.1	+12	+53.6
-10.6	+13	+55.4
-10.0	+14	+57.2
-9.4	+15	+59.0
-8.9	+16	+60.8
-8.3	+17	+62.6
-7.8	+18	+64.4
-7.2	+19	+66.2

TEMPERATURE		
°C	°C or °F	°F
-6.7	+20	+68.0
-6.1	+21	+69.8
-5.5	+22	+71.6
-5.0	+23	+73.4
-4.4	+24	+75.2
-3.9	+25	+77.0
-3.3	+26	+78.8
-2.8	+27	+80.6
-2.2	+28	+82.4
-1.7	+29	+84.2
-1.1	+30	+86.0
-0.6	+31	+87.8
0.0	+32	+89.6
+6	+33	+91.4
+1.1	+34	+93.2
+1.7	+35	+95.0
+2.2	+36	+96.8
+2.8	+37	+98.6
+3.3	+38	+100.4
+3.9	+39	+102.2
+4.4	+40	+104.0
+5.0	+41	+105.8
+5.5	+42	+107.6
+6.1	+43	+109.4
+6.7	+44	+111.2
+7.2	+45	+113.0
+7.8	+46	+114.8
+8.3	+47	+116.6
+8.9	+48	+118.4
+9.4	+49	+120.2
+10.0	+50	+122.0
+10.6	+51	+123.8
+11.1	+52	+125.6
+11.7	+53	+127.4
+12.2	+54	+129.2
+12.8	+55	+131.0
+13.3	+56	+132.8
+13.9	+57	+134.6
+14.4	+58	+136.4
+15.0	+59	+138.2
+15.6	+60	+140.0
+16.1	+61	+141.8
+16.7	+62	+143.6
+17.2	+63	+145.4
+17.8	+64	+147.2
+18.3	+65	+149.0
+18.9	+66	+150.8
+19.4	+67	+152.6
+19.9	+68	+154.4
+20.6	+69	+156.2
+21.1	+70	+158.0
+21.7	+71	+159.8
+22.2	+72	+161.6
+22.8	+73	+163.4
+23.3	+74	+165.2
+23.9	+75	+167.0
+24.4	+76	+168.8
+25.0	+77	+170.6
+25.6	+78	+172.4
+26.1	+79	+174.2

TEMPERATURE		
°C	°C or °F	°F
+26.7	+80	+176.0
+27.2	+81	+177.8
+27.8	+82	+179.6
+28.3	+83	+181.4
+28.9	+84	+183.2
+29.4	+85	+185.0
+30.0	+86	+186.8
+30.6	+87	+188.6
+31.1	+88	+190.4
+31.7	+89	+192.2
+32.2	+90	+194.0
+32.8	+91	+195.8
+33.3	+92	+197.6
+33.9	+93	+199.4
+34.4	+94	+201.2
+35.0	+95	+203.0
+35.6	+96	+204.8
+36.1	+97	+206.6
+36.7	+98	+208.4
+37.2	+99	+210.2
+37.8	+100	+212.0
+38.3	+101	+213.8
+38.9	+102	+215.6
+39.4	+103	+217.4
+40.0	+104	+219.2
+40.6	+105	+221.0
+41.1	+106	+222.8
+41.7	+107	+224.6
+42.2	+108	+226.4
+42.8	+109	+228.2
+43.3	+110	+230.0
+43.9	+111	+231.8
+44.4	+112	+233.6
+45.0	+113	+235.4
+45.6	+114	+237.2
+46.1	+115	+239.0
+46.7	+116	+240.8
+47.2	+117	+242.6
+47.8	+118	+244.4
+48.3	+119	+246.2
+48.9	+120	+248.0
+49.4	+121	+249.8
+50.0	+122	+251.6
+50.6	+123	+253.4
+51.1	+124	+255.2
+51.7	+125	+257.0
+52.2	+126	+258.8
+52.8	+127	+260.6
+53.3	+128	+262.4
+53.9	+129	+264.2
+54.4	+130	+266.0
+55.0	+131	+267.8
+55.6	+132	+269.6
+56.1	+133	+271.4
+56.7	+134	+273.2
+57.2	+135	+275.0
+57.8	+136	+276.8
+58.3	+137	+278.6
+58.9	+138	+280.4
+59.4	+139	+282.2

TEMPERATURE		
°C	°C or °F	°F
+60.0	+140	+284.0
+60.6	+141	+285.8
+61.1	+142	+287.6
+61.7	+143	+289.4
+62.2	+144	+291.2
+62.8	+145	+293.0
+63.3	+146	+294.8
+63.9	+147	+296.6
+64.4	+148	+298.4
+65.0	+149	+300.2
+65.6	+150	+302.0
+66.1	+151	+303.8
+66.7	+152	+305.6
+67.2	+153	+307.4
+67.8	+154	+309.2
+68.3	+155	+311.0
+68.9	+156	+312.8
+69.4	+157	+314.6
+70.0	+158	+316.4
+70.6	+159	+318.2
+71.1	+160	+320.0
+71.7	+161	+321.8
+72.2	+162	+323.6
+72.8	+163	+325.4
+73.3	+164	+327.2
+73.9	+165	+329.0
+74.4	+166	+330.8
+75.0	+167	+332.6
+75.6	+168	+334.4
+76.1	+169	+336.2
+76.7	+170	+338.0
+77.2	+171	+339.8
+77.8	+172	+341.6
+78.3	+173	+343.4
+78.9	+174	+345.2
+79.4	+175	+347.0
+80.0	+176	+348.8
+80.6	+177	+350.6
+81.1	+178	+352.4
+81.7	+179	+354.2
+82.2	+180	+356.0
+82.8	+181	+357.8
+83.3	+182	+359.6
+83.9	+183	+361.4
+84.4	+184	+363.2
+85.0	+185	+365.0
+85.6	+186	+366.8
+86.1	+187	+368.6
+86.7	+188	+370.4
+87.2	+189	+372.2
+87.8	+190	+374.0
+88.3	+191	+375.8
+88.9	+192	+377.6
+89.4	+193	+379.4
+90.0	+194	+381.2
+90.6	+195	+383.0
+91.1	+196	+384.8
+91.7	+197	+386.6
+92.2	+198	+388.4
+92.8	+199	+390.2

NOTES

