



**AIR-COOLED
SCROLL CHILLERS
STYLE D**



R-22

YCAL0012 – YCAL0065

50 AND 60HZ

10 – 61 TON

35 – 214 KW

Table of Contents

<i>FORM 150.64-EG1 (1205)</i>	1
<i>Introduction</i>	3
<i>Specification</i>	4
<i>Options and Accessories</i>	7
<i>Selection Data</i>	11
<i>Design Parameters</i>	13
<i>Water Pressure Drop - Single Circuit</i>	14
<i>Water Pressure Drop - Dual Circuit</i>	16
<i>Ratings - R-22 (60Hz - English Units)</i>	18
<i>Ratings - R-22 (60Hz - SI Units)</i>	26
<i>Ratings - R-22 (50Hz - English Units)</i>	30
<i>Ratings - R-22 (50Hz - SI Units)</i>	38
<i>Part Load Ratings - 60 Hz R-22 (English Units)</i>	42
<i>Part Load Ratings - 60 Hz R-22 (SI)</i>	43
<i>Part Load Ratings - 50 Hz R-22 (English Units)</i>	44
<i>Part Load Ratings - 50 Hz R-22 (SI)</i>	45
<i>Physical Data</i>	46
<i>Sound Data</i>	48
<i>Dimensions - YCAL0012 (English)</i>	50
<i>Dimensions - (English)</i>	52
<i>Dimensions - (SI)</i>	62
<i>Isolator Selections</i>	98
<i>Isolator Details (cont'd)</i>	100
<i>Electrical Data</i>	102
<i>Electrical Data - 60Hz</i>	104
<i>Electrical Data - 50Hz</i>	106
<i>Power Wiring</i>	108
<i>Control Wiring</i>	111
<i>Application Data</i>	112
<i>Guide Specifications</i>	114

Preliminary

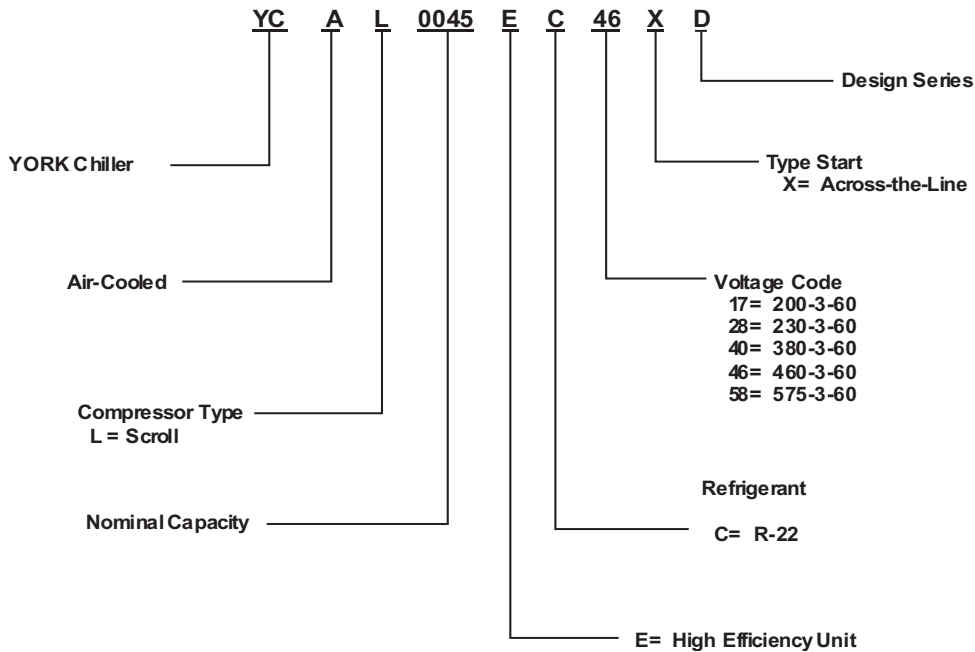

Introduction



YORK Air-Cooled Scroll Chillers provide chilled water for all air conditioning applications using central station air handling or terminal units. They are completely self-contained and are designed for outdoor (roof or ground level) installation. Each unit includes hermetic scroll compressors, a liquid cooler, air cooled condenser, and a weather resistant microprocessor control center, all mounted on a pressed-steel base.

Specification

GENERAL

The 10 - 61 Ton (35 - 214 kW) YCAL models are shipped complete from the factory ready for installation and use.

The unit is pressure-tested, evacuated, and fully charged with Refrigerant-22 (HCFC-22) and includes an initial oil charge. After assembly, a complete operational test is performed with water flowing through the cooler to assure that the refrigeration circuit operates correctly.

The unit structure is heavy-gauge, galvanized steel. This galvanized steel is coated with baked-on powder paint, which, when subjected to ASTM B117 1000 hour, salt spray testing, yields a minimum ASTM 1654 rating of "6". Corrosion resistant wire mesh panels are added to protect the condenser coil from incidental damage and restrict unauthorized access to internal components. **Units are designed in accordance with NFPA 70 (National Electric Code), ASHRAE/ANSI 15 Safety code for mechanical refrigeration, ASME, Listed and labeled with Intertek Testing Services (ETL) and rated in accordance with ARI Standard 550/590-2003.**

COMPRESSORS

The chiller has suction-gas cooled, hermetic, scroll compressors. The YCAL compressors incorporate a compliant scroll design in both the axial and radial direction. All rotating parts are statically and dynamically balanced. A large internal volume and oil reservoir provides greater liquid tolerance. Compressor crankcase heaters are also included for extra protection against liquid migration.

COOLER

The cooler is equipped with a heater controlled by a separate thermostat. The heater provides freeze protection for the cooler down to -20°F (-29°C) ambient. The

cooler is covered with 3/4" (19mm) flexible, closed-cell, foam insulation (K~0.25).

Brazed plate heat exchangers shall be UL (Underwriters Laboratories) listed. Installing contractor must include accommodations in the chilled water piping to allow proper drainage and venting of the heat exchanger. Water inlet and outlet connections are grooved for compatibility with factory supplied victaulic connections.

A strainer with a mesh size between .5 and 1.5 mm (40 mesh) is recommended upstream of the heat exchanger to prevent clogging.

CONDENSER

Coils – Fin and tube condenser coils of seamless, internally-enhanced, high-condensing-coefficient, corrosion resistant copper tubes are arranged in staggered rows, mechanically expanded into aluminum fins. Integral subcooling is included. The design working pressure of the coil is 450 PSIG (31 bar).

Low Sound Fans – The condenser fans are composed of corrosion resistant aluminum hub and glass-fiberreinforced composite blades molded into a low noise airfoil section. They are designed for maximum efficiency and are statically and dynamically balanced for vibration free operation. They are directly driven by independent motors, and positioned for vertical air discharge. All blades are statically and dynamically balanced for vibration-free operation. The fan guards are constructed of heavy-gauge, rust-resistant, PVCcoated steel wire.

Motors – The fan motors are Totally Enclosed Air-Over, squirrel-cage type, current protected. They feature ball bearings that are double-sealed and permanently lubricated.

MILLENNIUM CONTROL CENTER

All controls are contained in a NEMA 3R/12 (and equivalent to IP55*) cabinet with hinged outer door and includes:

Liquid Crystal Display with Light Emitting Diode back-lighting for outdoor viewing:

- Two display lines
- Twenty characters per line

Color coded 12-button non-tactile keypad with sections for:

DISPLAY/PRINT of typical information:

- Chilled liquid temperatures
- Ambient temperature
- System pressures (each circuit)
- Operating hours and starts (each compressor)
- Print calls up to the liquid crystal display:
- Operating data for the systems
- History of fault shutdown data for up to the last six fault shutdown conditions
- An RS-232 port, in conjunction with this press-to-print button, is provided to permit the capability of hard copy print-outs via a separate printer (by others).

ENTRY section to:

ENTER setpoints or modify system values

SETPOINTS updating can be performed to:

- Chilled liquid temperature setpoint and range
- Remote reset temperature range
- Set daily schedule/holiday for start/stop
- Manual override for servicing
- Low and high ambient cutouts
- Number of compressors
- Low liquid temperature cutout
- Low suction pressure cutout
- High discharge pressure cutout
- Anti-recycle timer (compressor start cycle time)
- Anti-coincident timer (delay compressor starts)

UNIT section to:

- Set time
- Set unit options

UNIT ON/OFF switch

The microprocessor control center is capable of displaying the following:

- Return and leaving liquid temperature
- Low leaving liquid temperature cutout setting
- Low ambient temperature cutout setting
- Outdoor air temperature
- English or Metric data
- Suction pressure cutout setting
- Each system suction pressure
- Discharge pressure (optional)
- Liquid Temperature Reset via a YORK ISN DDC or Building Automation System (by others) via:
 - a pulse width modulated (PWM) input as standard
 - a 4-20 milliamp or 0 -10 VDC input, or contact closure with the optional B.A.S. interface option
- Anti-recycle timer status for each system
- Anti-coincident system start timer condition
- Compressor run status
- No cooling load condition
- Day, date and time
- Daily start/stop times
- Holiday status
- Automatic or manual system lead/lag control
- Lead system definition
- Compressor starts & operating hours (each compressor)
- Status of hot gas valves, evaporator heater and fan operation
- Run permissive status
- Number of compressors running
- Liquid solenoid valve status
- Load & unload timer status
- Water pump status

* Intensity of Protection European Standard

Provisions are included for: pumpdown at shutdown; optional remote chilled water temperature reset and two steps of demand load limiting from an external building automation system. Unit alarm contacts are standard.

The operating program is stored in non-volatile memory (EPROM) to eliminate chiller failure due to AC powered failure/battery discharge. Programmed setpoints are retained in lithium battery-backed RTC memory for 5 years minimum.

POWER PANEL

Each panel contains:

- Compressor power terminals
- Compressor motor starting contactors per I.E.C.**
- Control power terminals to accept incoming for 115-1-60 control power
- Fan contactors & overload current protection

The power wiring is routed through liquid-tight conduit to the compressors and fans.

Preliminary

** International Electrotechnical Commission

Options and Accessories

POWER OPTIONS:

COMPRESSOR POWER CONNECTIONS – Single-point (YCAL0041-0065) terminal block connection(s) are provided as standard. The following power connections are available as options. (See electrical data for specific voltage and options availability.) **(Factory-Mounted.)**

SINGLE-POINT SUPPLY TERMINAL BLOCK – (standard on YCAL0041 - 0065 models). Includes enclosure, terminal-block and interconnecting wiring to the compressors. Separate external protection must be supplied, by others, in the incoming compressor-power wiring. (Do not include this option if either the SinglePoint NonFused Disconnect Switch or Single-Point Circuit Breaker options have been included.)

SINGLE-POINT NON-FUSED DISCONNECT SWITCH – Unit-mounted disconnect switch with external, lockable handle (in compliance with Article 440-14 of N.E.C.), can be supplied to isolate the unit power voltage for servicing. Separate external fusing must be supplied, by others in the power wiring, which must comply with the National Electrical Code and/or local codes.

SINGLE-POINT CIRCUIT BREAKER – A unit mounted circuit breaker with external, lockable handle (in compliance with N.E.C. Article 440-14), can be supplied to isolate the power voltage for servicing. (This option includes the Single-Point Power connection.)

CONTROL TRANSFORMER – Converts unit power voltage to 115-1-60 (0.5 or 1.0 KVA capacity). Factory mounting includes primary and secondary wiring between the transformer and the control panel. **(Factory-Mounted.)**

POWER FACTOR CORRECTION CAPACITORS – Will correct unit compressor power factors to a 0.90-0.95. **(Factory-Mounted.)**

CONTROL OPTIONS:

AMBIENT KIT (LOW) – Units will operate to 25°F (-4°C). This accessory includes all necessary components to permit chiller operation to 0°F (-18°C). (This option includes the Discharge Pressure Transducer / Readout Capability option.) For proper head pressure control in applications below 25°F (-4°C), where wind gusts may exceed five mph, it is recommended that Optional Condenser Louvered Enclosure Panels also be included. **(Factory-Mounted.)**

AMBIENT KIT (HIGH) – Required if units are to operate when the ambient temperature is above 115°F (46°C). Includes discharge pressure transducers. (This option includes the Discharge Pressure Transducer / Readout-

Capability option.) **(Field-Mounted.)**

BUILDING AUTOMATION SYSTEM INTERFACE – The factory addition of a Printed Circuit Board to accept a 4-20 milliamp, 0-10VDC or contact closure input to reset the leaving chiller liquid temperature from a Building Automation System. (Only one of following options can be offered on a unit at a time: BAS, Remote Control Panel or Multi-unit Sequence Control.) **(Factory-Mounted.)** (The standard unit capabilities include remote startstop, remote water temperature reset via a PWM input signal or up to two steps of demand (load) limiting depending on model.) (The standard control panel can be directly connected to a YORK Building Automated System via the standard onboard RS485 communication port.)

LANGUAGE LCD AND KEYPAD DISPLAY – Spanish, French, and German unit LCD controls and keypad display available. Standard language is English.

DISCHARGE PRESSURE TRANSDUCERS AND READ-OUT CAPABILITY – The addition of pressure transducers allows models to sense and display discharge pressure. This is recommended for brine chilling applications. (This option is included with either the low or high ambient kits.) **(Factory-Mounted.)**

- **Suction Pressure Transducers:** Permits unit to sense and display suction pressure. This capability is standard on YCAL0041-0065 models.

MOTOR CURRENT MODULE – Capable of monitoring compressor motor current. Provides extra protection against compressor reverse rotation, phase-loss and phase imbalance. Option consists of one module per electrical system. **(Factory-Mounted.)**

OPTIVIEW REMOTE CONTROL PANEL - Graphical interface panel to remotely control and monitor up to 8 different units. (Refer to form 201.18-SG4 for detailed information)

MULTI-UNIT SEQUENCING – A separate Sequencing Control Center is provided to handle sequencing control of up to eight chillers in parallel based on mixed liquid temperature (interconnecting wiring by others). (Only one of following options can be offered on a unit at a time: BAS, Remote Control Panel or Multi-unit Sequence Control.) **(Factory-Mounted.)**

COMPRESSOR, PIPING, EVAPORATOR OPTIONS:

LOW TEMPERATURE BRINE – Required for brine chilling below 30°F (-1°C) leaving brine temperature for

YCAL0041 - 0065 models. Option includes resized thermal expansion valve. **(Factory-Mounted)**

CHICAGO CODE RELIEF VALVES – Unit will be provided with relief valves to meet Chicago code requirements. **(Factory-Mounted)**

SERVICE ISOLATION VALVE – Service suction and discharge (ball type) isolation valves are added to unit per system. This option also includes a system high pressure relief valve in compliance with ASHRAE 15. **(Factory-Mounted)**

HOT GAS BY-PASS – Permits continuous, stable operation at capacities below the minimum step of compressor unloading to as low as 5% capacity (depending on both the unit and operating conditions) by introducing an artificial load on the cooler. Hot gas by-pass is installed on only refrigerant system #1 on two-circuited units. **(Factory-Mounted)**

DX COOLER 300 PSIG (21 bar) DWP WATERSIDE – The waterside will be of 300 PSIG (21 bar) instead of the standard 150 PSIG DWP. 300 PSIG R.F. flanges are included on the DX cooler nozzles. **(Factory-Mounted.)** The companion flanges will be field-supplied by others.

FLANGES (VICTAULIC TYPE) – Consists of two (2) Flange adapters for grooved end pipe (standard 150 psi [10.5 bar] cooler).

FLOW SWITCH – The flow switch or its equivalent must be furnished with each unit.

150 PSIG (10.5 bar) DWP – For standard units. Johnson Controls model F61MG-1C Vapor-proof SPDT, NEMA 4X switch (150 PSIG [10.5 bar] DWP), -20°F to 250°F (-29°C to 121°C), with 1" NPT connection for upright mounting in horizontal pipe. **(Field-Mounted.)**

300 psig (21 bar) DWP – For units with optional 300 PSIG (21 bar) DX cooler. McDonnell & Miller model FS74W Vapor-proof SPDT, NEMA 4X switch (300 PSIG (21 bar) DWP), -20°F to 300°F (-29°C to 149°C), with 1¼ inch MPT connection for upright mounting in horizontal pipe. **(Field-Mounted.)**

DIFFERENTIAL PRESSURE SWITCH – Alternative to an above mentioned flow switch. Pretempco model DPS300AP40PF-82582-5 (300 psi max. working pressure), SPDT 5 amp 125/250VAC switch, Range 0 - 40 PSID, deadband 0.5 - 0.8 psi, with 1/4" NPTE Pressure Connections.

REMOTE DX COOLER – A split system arrangement with the cooler, leaving & return water sensors, liquid line

solenoid valves, filter driers, sightglasses & TXVs shipped loose for field connection to the air-cooled condensing section. The DX cooler and outdoor section will have a nitrogen holding charge. Interconnecting rigid piping, wiring and refrigerant are by others. Includes YORK Service startup. See Form 150.62-NM1.1 (200) for other application information. (This option includes the Crankcase Heater option.) **(Field-Mounted.)**

CONDENSER AND CABINET OPTIONS:

Condenser coil protection against corrosive environments is available by choosing any of the following options. For additional application recommendations, refer to FORM 150.12-ES1. **(Factory-Mounted.)**

PRE-COATED FIN CONDENSER COILS – The unit's coils are constructed with black epoxy coated aluminum fins. This can provide corrosion resistance comparable to copper-fin coils in typical seashore locations. Either these or the post-coated coils (below), are recommended for units being installed at the seashore or where salt spray may hit the unit.

POST-COATED DIPPED CONDENSER COILS – The unit's coils are constructed with dipped-cured condenser coils. This is another choice for seashore and other corrosive applications (with the exception of strong alkalis, oxidizers and wet bromine, chlorine and fluorine in concentrations greater than 100 ppm).

COPPER FIN CONDENSER COILS – The unit's coils are constructed with copper fins. (This is not recommended for units in areas where they may be exposed to acid rain.)

ENCLOSURE PANELS (UNIT) – Tamperproof Enclosure Panels prevent unauthorized access to units. Enclosure Panels can provide an aesthetically pleasing alternative to expensive fencing. Additionally, for proper head pressure control, YORK recommends the use of :

LOUVERED PANELS (Full Unit) – Louvered panels surround the front, back, and sides of the unit. They prevent unauthorized access and visually screen unit components. Unrestricted air flow is permitted through generously sized louvered openings. This option is applicable for any outdoor design ambient temperature up to 115°F (46°C). **(Factory-Mounted.)**

SOUND ATTENUATION – One or both of the following sound attenuation options are recommended for residential or other similar sound-sensitive locations. Louvered Panels can be ordered for winter applications where wind gusts may exceed five miles per hour. The following types

of enclosure options are available:

COMPRESSOR ACOUSTIC SOUND BLANKET – Each compressor is individually enclosed by an acoustic sound blanket. The sound blankets are made with one layer of acoustical absorbent textile fiber of 5/8” (15mm) thickness; one layer of anti-vibrating heavy material thickness of 1/8” (3mm). Both are closed by two sheets of welded PVC, reinforced for temperature and UV resistance. (**Factory-Mounted.**)

ULTRA QUIET FANS – Lower RPM, 8-pole fan motors are used with steeper-pitch fans. (**Factory-Mounted.**)

VIBRATION ISOLATORS – Level adjusting, spring type 1” (25.4mm) or seismic deflection or neoprene pad isolators for mounting under unit base rails. (**Field-Mounted.**)

Preliminary



This page intentionally left blank.

Preliminary

Selection Data

GUIDE TO SELECTION

Capacity ratings for the YCAL Packaged Air-Cooled Liquid Chillers, shown on pages 16 through 39 cover the majority of design applications for these units. For unusual applications or uses beyond the scope of this catalog, please consult your nearest YORK Office or representative.

SELECTION RULES

- Ratings** – Ratings may be interpolated, but must not be extrapolated. The Ratings given on pages 16 through 39 and the DESIGN PARAMETERS given on page 11 indicate the limits of application for these chillers.
- Cooler Water** – Ratings are based upon 2.4 GPM per ton which is equal to a 10°F chilled water range and a 0.0001 fouling factor for the cooler at sea level. Tables on pages 16 through 39 give capacity, compressor kW required, cooler GPM and unit EER.
- Condenser** – Ratings are given in terms of air on condenser in degrees Fahrenheit.
- Copper Fin Condenser Ratings** – Since the thermal conductivity of copper is slightly higher than aluminum, apply the following corrections to the standard ratings. Tons x 0.97 and compressor kW x 0.99.
- Performance Data Correction Factors** – Ratings are based on 0.0001 cooler fouling factor, 10°F chilled water range and at sea level. For operation at different conditions, apply the appropriate correction factor from the following table.
- Ethylene Glycol Correction Factors** – The following factors are to be applied to the standard ratings for

FOULING FACTOR					
ALTITUDE	TEMP SPLIT	0.0001		0.00025	
		TONS	COMPR KW	TONS	COMPR KW
SEA LEVEL	8	0.990	0.998	0.979	0.996
	10	1.000	1.000	0.991	0.998
	12	1.012	1.003	1.002	1.001
	14	1.021	1.005	1.012	1.003
2000 FT.	8	0.987	1.005	0.978	1.003
	10	0.997	1.008	0.988	1.006
	12	1.009	1.010	1.000	1.008
	14	1.018	1.012	1.009	1.010
4000 FT.	8	0.983	1.014	0.975	1.012
	10	0.994	1.016	0.985	1.014
	12	1.005	1.019	1.111	1.017
	14	1.014	1.021	1.006	1.019
6000 FT.	8	0.980	1.023	0.971	1.021
	10	0.990	1.025	0.982	1.023
	12	1.002	1.028	0.993	1.026
	14	1.011	1.030	1.002	1.028

units cooling ethylene glycol.

ETHYLENE GLYCOL					
% WEIGHT	TONS	COMPR KW	GPM °F/TON	PRESS DROP	FREEZE PT
10	0.996	0.999	24.3	1.014	26.2
20	0.991	0.998	25.1	1.104	17.9
30	0.984	0.997	25.9	1.234	6.7
40	0.976	0.995	26.9	1.399	-8.1
50	0.968	0.994	28.0	1.599	-28.9

- Propylene Glycol Correction Factors** – The following factors are to be applied to the standard ratings for units cooling propylene glycol.

PROPYLENE GLYCOL					
% WEIGHT	TONS	COMPR KW	GPM °F/TON	PRESS DROP	FREEZE PT
10	0.995	0.999	24.0	1.049	26
20	0.984	0.997	24.3	1.124	19
30	0.973	0.994	24.9	1.258	9
40	0.960	0.992	25.6	1.430	-6
50	0.943	0.989	26.6	1.650	-28

METHOD OF SELECTION

To select of YORK Packaged Air-Cooled Liquid Chiller, the following data must be known:

- Design Capacity in tons refrigeration (TR).
- Entering and Leaving Liquid Temperatures.
- Outside ambient air temperature in degrees F.
- GPM of chilled liquid.

Determine capacity requirements from the following formula:

$$\text{GPM} = \frac{\text{TR} \times 24}{\text{RANGE } (^\circ\text{F})}$$

EXAMPLE – WATER CHILLING

- Given: Provide a capacity of 50 tons at 42 F leaving water at 10 F range. 0.0001FF, 85 F air on the condenser, at sea level and 60 Hz.
- Find: Unit Size, Compressor KW Output
- From the ratings on page 18.

Select: **YCAL0061** (English Units)

- a. 56.1 Tons
- b. 55.9 Compressor KW
- c. 10.7 Unit EER

4. Calculate Compressor kW at 50 Tons:

$$kW = \frac{50}{56.1} \times 55.9 kW = 49.8 kW$$

5. Calculate GPM:

$$GPM = \frac{(50 \text{ Tons}) \times 24}{10^\circ F \text{ Range}} = 120 \text{ GPM}$$

6. From page 14, read 6 ft of water cooler pressure drop from GPM:

7. A **YCAL0061** is suitable.

EXAMPLE - BRINE CHILLING

Example - Brine Chilling

1. Given: Provide a capacity of 34 tons cooling 30% by weight Ethylene Glycol from 50 F to 40 F, 0.00025FF, 95 F air on the condenser, 60 Hz and 4000 ft. altitude.
2. Determine:
 - a. Unit Size
 - b. KW Input
 - c. Ethylene Glycol GPM
 - d. Cooler Pressure Drop
3. See E.G. correction factors, for 30% by weight E.G.

READ: 0.984 Tons Factor
 0.997 Compr. KW factor
 26.1 Gal./ F/Tons Factor

4. See Performance Data Correction Factors for 0.00025 fouling factor and 4,000 ft. altitude.

READ: 0.975 Tons factor
 1.012 kW factor

5. From RATINGS on page 16.

SELECT: YCAL0045 (English Units)
 35.3 Tons
 41.1 Compressor kW

6. Determine YCAL0045 brine cooling capacity and Compressor kW requirement from pg 14:
 - a. TONS: = 35.3 x 0.984 x 0.975 = 33.87
 - b. Compr. KW = 41.1 x 0.997 x 1.012 = 41.77
7. Determine average full load Compressor kW at 34

tons

$$\frac{34 \text{ tons}}{33.87 \text{ tons}} \times (41.77) = 41.93 \text{ Compressor kW}$$

8. Determine E.G. GPM:

$$GPM = \frac{\text{Tons} \times \text{Gal.}^\circ F / \text{min} / \text{Ton factor}}{\text{Range}}$$

$$GPM = \frac{34.0 \times 26.1}{10} = 88.7 \text{ (GPM)}$$

9. Determine Cooler Pressure Drop:

- a. See E.G. correction factors for 30% by weight E.G.

READ: 1.258 Pressure Drop factor

- b. See page 14 at 88.7 GPM for YCAL0045

READ: 6.5_Water H₂O PD

- c. Cooler Pressure Drop = 6.5 x 1.258 or 8.17

A **YCAL0045** is suitable.

Preliminary

Design Parameters

ENGLISH

YCAL	LEAVING WATER TEMPERATURE (°F)		COOLER FLOW (GPM)		AIR ON CONDENSER (°F)	
	MIN	MAX	MIN	MAX	MIN	MAX
0012	40	55			0	125
0018	40	55			0	125
0021	40	55			0	125
0025	40	55			0	125
0027	40	55			0	125
0032	40	55			0	125
0041	40	55	40	200	0	125
0045	40	55	40	200	0	125
0051	40	55	40	200	0	125
0055	40	55	60	300	0	125
0061	40	55	60	300	0	125
0065	40	55	60	300	0	125

SI UNITS

YCAL	LEAVING WATER TEMPERATURE (°C)		COOLER FLOW (L/S)		AIR ON CONDENSER (°C)	
	MIN	MAX	MIN	MAX	MIN	MAX
0012	4.4	12.8			-17.7	51.7
0018	4.4	12.8			-17.7	51.7
0021	4.4	12.8			-17.7	51.7
0025	4.4	12.8			-17.7	51.7
0027	4.4	12.8			-17.7	51.7
0032	4.4	12.8			-17.7	51.7
0041	4.4	12.8	2.5	12.6	-17.7	51.7
0045	4.4	12.8	2.5	12.6	-17.7	51.7
0051	4.4	12.8	2.5	12.6	-17.7	51.7
0055	4.4	12.8	3.8	18.9	-17.7	51.7
0061	4.4	12.8	3.8	18.9	-17.7	51.7
0065	4.4	12.8	3.8	18.9	-17.7	51.7

NOTES:

1. For leaving brine temperature below 40°F (4.4°C), contact your nearest YORK Office for application requirements.
2. For leaving water temperature higher than 55°F (12.8°C), contact the nearest YORK Office for application guidelines.
3. The evaporator is protected against freezing to -20°F (-28.8°C) with an electric heater as standard.
4. For operation at temperatures below 25°F (-3.9°C), the optional Low Ambient Kit will need to be installed on the system (for YCAL0041-0065 models only).
5. For operation at temperatures above 115°F (46.1°C), the optional High Ambient Kit will need to be installed on the system.

Water Pressure Drop - Single Circuit

ENGLISH

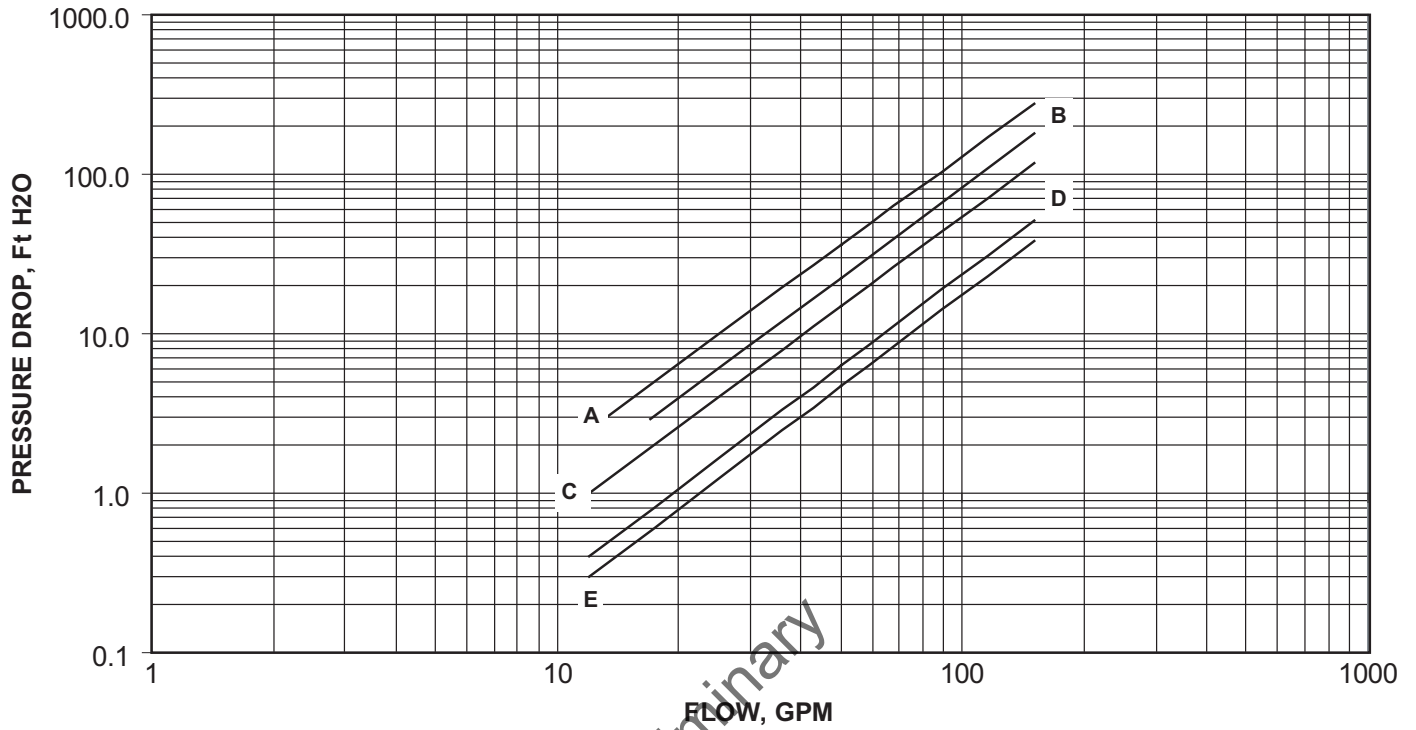

MOEL YCAL	COOLER CURVE
A	YCAL0012
B	YCAL0018
C	YCAL0021
D	YCAL0027/0025
E	YCAL0032

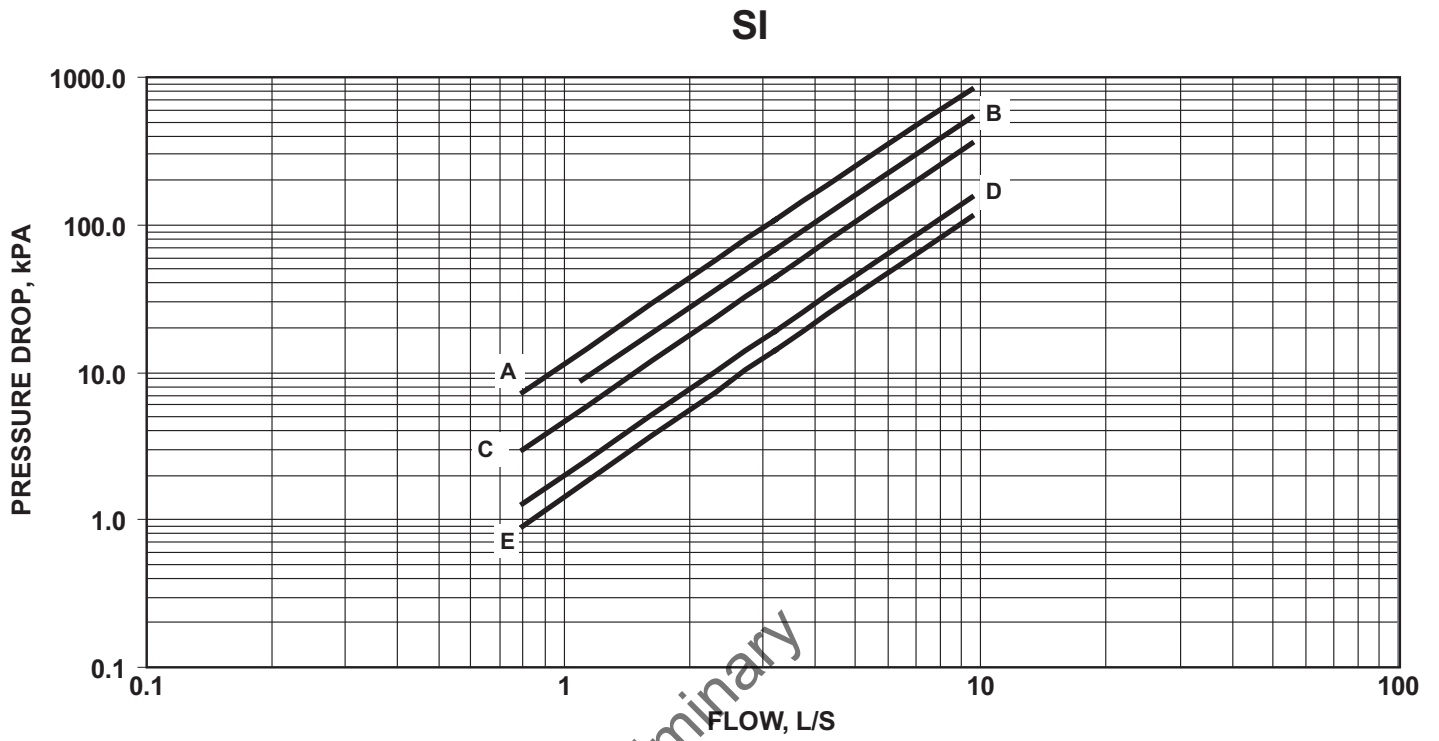

MOEL YCAL	COOLER CURVE
A	YCAL0012
B	YCAL0018
C	YCAL0021
D	YCAL0027/0025
E	YCAL0032

Water Pressure Drop - Dual Circuit

ENGLISH

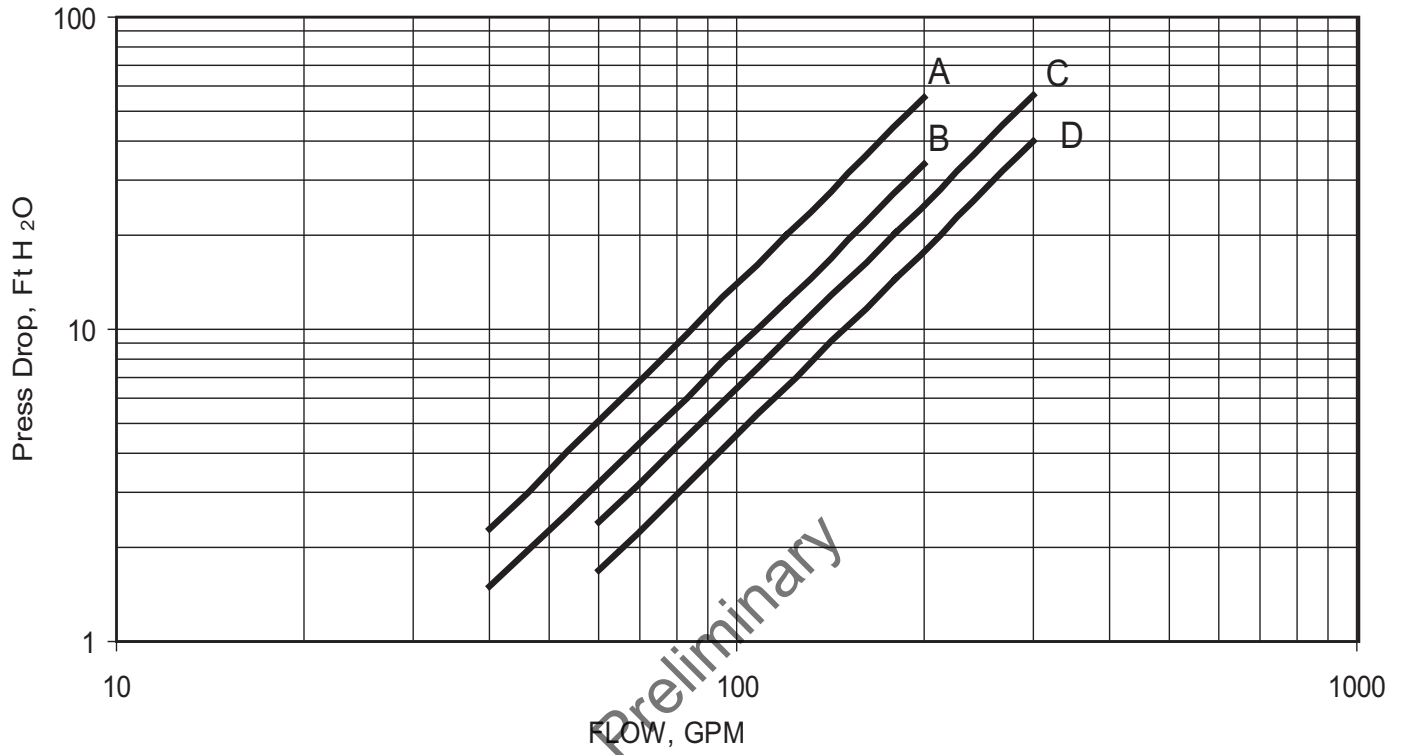

MODEL YCAL	COOLER CURVE
0041	A
0045,0051	B
0055	C
0061,0065	D

Note: Water Pressure Drop Curves may extend past the minimum and maximum water flow ranges. See page 13 for minimum and maximum flow points.

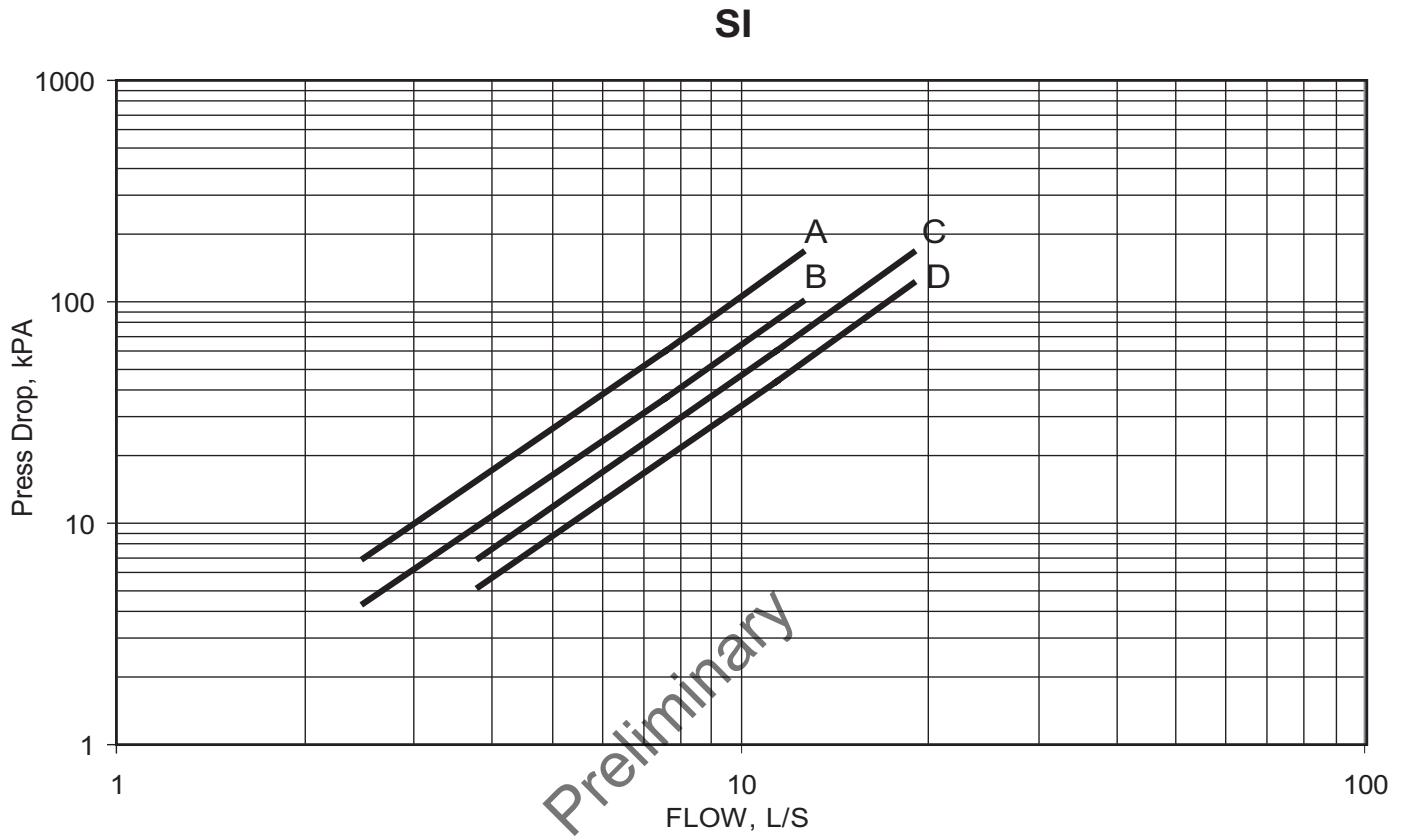

MODEL YCAL	COOLER CURVE
0041	A
0045,0051	B
0055	C
0061,0065	D

Note: Water Pressure Drop Curves may extend past the minimum and maximum water flow ranges. See page 13 for minimum and maximum flow points.

Ratings - R-22 (60Hz - English Units)

MODEL:YCAL0012EC **IPLV=13.8**

AIR TEMPERATURE ON - CONDENSER (°F)

LCWT (°F)	75.0			80.0			85.0			90.0			95.0			100.0		
	TONS	KW	EER	TONS	KW	EER	TONS	KW	EER	TONS	KW	EER	TONS	KW	EER	TONS	KW	EER
40.0	9.9	8.7	12.2	9.7	9.3	11.4	9.5	9.8	10.6	9.3	10.4	9.8	9.1	11.0	9.1	8.9	11.6	8.4
42.0	10.3	8.8	12.6	10.1	9.3	11.7	9.8	9.9	10.9	9.6	10.5	10.1	9.4	11.1	9.4	9.2	11.7	8.7
44.0	10.6	8.9	12.9	10.4	9.4	12.0	10.2	10.0	11.1	9.9	10.5	10.3	9.7	11.1	9.6	9.5	11.8	8.9
45.0	10.8	8.9	13.1	10.6	9.4	12.1	10.3	10.0	11.3	10.1	10.6	10.5	9.9	11.2	9.7	9.6	11.8	9.0
46.0	11.0	8.9	13.2	10.7	9.5	12.3	10.5	10.0	11.4	10.3	10.6	10.6	10.0	11.2	9.9	9.8	11.9	9.1
48.0	11.3	9.0	13.6	11.1	9.5	12.6	10.8	10.1	11.7	10.6	10.7	10.9	10.4	11.3	10.1	10.1	12.0	9.4
50.0	11.7	9.1	13.9	11.4	9.6	12.9	11.2	10.2	12.0	10.9	10.8	11.2	10.7	11.4	10.4	10.4	12.1	9.6

MODEL:YCAL0018EC **IPLV=13.4**

AIR TEMPERATURE ON - CONDENSER (°F)

LCWT (°F)	75.0			80.0			85.0			90.0			95.0			100.0		
	TONS	KW	EER	TONS	KW	EER	TONS	KW	EER	TONS	KW	EER	TONS	KW	EER	TONS	KW	EER
40.0	14.9	13.6	12.2	14.6	14.4	11.4	14.3	15.1	10.6	13.9	16.0	9.9	13.6	16.8	9.1	13.2	17.8	8.5
42.0	15.4	13.8	12.5	15.1	14.5	11.7	14.8	15.3	10.9	14.4	16.1	10.1	14.1	17.0	9.4	13.7	17.9	8.7
44.0	15.9	13.9	12.8	15.6	14.7	12.0	15.2	15.4	11.1	14.9	16.3	10.3	14.5	17.2	9.6	14.1	18.1	8.9
45.0	16.2	14.0	12.9	15.8	14.7	12.1	15.5	15.5	11.3	15.1	16.3	10.5	14.8	17.2	9.7	14.4	18.2	9.0
46.0	16.4	14.1	13.1	16.1	14.8	12.2	15.7	15.6	11.4	15.4	16.4	10.6	15.0	17.3	9.8	14.6	18.3	9.1
48.0	17.0	14.2	13.4	16.6	15.0	12.5	16.2	15.8	11.6	15.9	16.6	10.8	15.5	17.5	10.1	15.1	18.4	9.3
50.0	17.5	14.4	13.6	17.1	15.1	12.7	16.8	15.9	11.9	16.4	16.7	11.1	16.0	17.6	10.3	15.6	18.6	9.5

MODEL:YCAL0021EC **IPLV=13.6**

AIR TEMPERATURE ON - CONDENSER (°F)

LCWT (°F)	75.0			80.0			85.0			90.0			95.0			100.0		
	TONS	KW	EER	TONS	KW	EER	TONS	KW	EER	TONS	KW	EER	TONS	KW	EER	TONS	KW	EER
40.0	18.0	16.3	12.5	17.6	17.2	11.6	17.2	18.2	10.7	16.8	19.3	9.9	16.4	20.4	9.2	15.9	21.6	8.5
42.0	18.6	16.5	12.8	18.2	17.4	11.8	17.8	18.4	11.0	17.3	19.5	10.2	16.9	20.6	9.4	16.5	21.8	8.7
44.0	19.2	16.7	13.0	18.7	17.6	12.1	18.3	18.6	11.2	17.9	19.7	10.4	17.4	20.8	9.6	17.0	22.0	8.9
45.0	19.4	16.8	13.1	19.0	17.7	12.2	18.6	18.7	11.3	18.2	19.8	10.5	17.7	20.9	9.7	17.2	22.1	9.0
46.0	19.7	16.9	13.3	19.3	17.8	12.3	18.9	18.8	11.4	18.4	19.9	10.6	18.0	21.0	9.8	17.5	22.2	9.1
48.0	20.3	17.0	13.5	19.9	18.0	12.6	19.4	19.0	11.7	19.0	20.1	10.8	18.5	21.2	10.0	18.0	22.4	9.3
50.0	20.9	17.2	13.8	20.5	18.2	12.8	20.0	19.2	11.9	19.6	20.3	11.0	19.1	21.4	10.2	18.6	22.6	9.5

NOTES:

1. kW = Compressor Input Power
2. EER = Chiller EER (includes power from compressors, fans, and the control panels 0.8 kW)
3. LCWT = Leaving Chilled Water Temperature
4. Ratings are based upon 2.4 GPM cooler water per ton and 0.0001 fouling factor
5. Rated in accordance with ARI Standard 550/590-98
6. The shaded points are certified in accordance with ARI Standard 550/590-98

MODEL: YCAL0012EC **IPLV=13.8****AIR TEMPERATURE ON - CONDENSER (°F)**

LCWT (°F)	105			110.0			115.0			120.0			125.0		
	TONS	KW	EER	TONS	KW	EER	TONS	KW	EER	TONS	KW	EER	TONS	KW	EER
40.0	8.6	12.3	7.8	8.4	13.1	7.2	8.2	13.9	6.6	7.9	14.8	6.0	7.6	15.7	5.5
42.0	8.9	12.4	8.0	8.7	13.2	7.4	8.4	14.0	6.8	8.2	14.8	6.2	7.9	15.8	5.6
44.0	9.2	12.5	8.2	9.0	13.3	7.6	8.7	14.1	7.0	8.5	14.9	6.4	8.2	15.8	5.8
45.0	9.4	12.5	8.3	9.1	13.3	7.7	8.9	14.1	7.1	8.6	15.0	6.5	8.3	15.9	5.9
46.0	9.6	12.6	8.4	9.3	13.3	7.8	9.0	14.1	7.2	8.8	15.0	6.6	8.5	15.9	6.0
48.0	9.9	12.7	8.7	9.6	13.4	8.0	9.3	14.2	7.4	9.0	15.1	6.7	4.8	7.2	7.1
50.0	10.2	12.8	8.9	9.9	13.5	8.2	9.6	14.3	7.6	9.3	15.2	6.9	5.0	7.2	7.3

MODEL: YCAL0018EC **IPLV=13.4****AIR TEMPERATURE ON - CONDENSER (°F)**

LCWT (°F)	105			110.0			115.0			120.0			125.0		
	TONS	KW	EER	TONS	KW	EER	TONS	KW	EER	TONS	KW	EER	TONS	KW	EER
40.0	12.9	18.8	7.8	12.5	19.9	7.2	12.1	21.0	6.6	11.7	22.2	6.1	11.3	23.5	5.6
42.0	13.3	18.9	8.0	12.9	20.0	7.4	12.5	21.1	6.8	12.1	22.3	6.2	6.4	10.4	6.8
44.0	13.8	19.1	8.2	13.4	20.2	7.6	13.0	21.3	7.0	12.5	22.5	6.4	6.6	10.4	7.0
45.0	14	19.2	8.3	13.6	20.3	7.7	13.2	21.4	7.1	12.8	22.6	6.5	6.8	10.4	7.1
46.0	14.2	19.3	8.4	13.8	20.3	7.8	13.4	21.5	7.1	13.0	22.7	6.6	6.9	10.5	7.2
48.0	14.7	19.4	8.6	14.3	20.5	8.0	13.8	21.7	7.3	13.4	22.9	6.7	7.1	10.5	7.4
50.0	15.1	19.6	8.8	14.7	20.7	8.1	14.3	21.8	7.5	13.8	23.0	6.9	7.4	10.6	7.6

MODEL: YCAL0021EC **IPLV=13.6****AIR TEMPERATURE ON - CONDENSER (°F)**

LCWT (°F)	105			110.0			115.0			120.0			125.0		
	TONS	KW	EER	TONS	KW	EER	TONS	KW	EER	TONS	KW	EER	TONS	KW	EER
40.0	15.5	22.9	7.8	15.0	24.2	7.2	14.6	25.6	6.6	14.1	27.1	6.0	7.7	12.4	6.9
42.0	16	23.1	8.0	15.5	24.4	7.3	15.0	25.8	6.7	14.5	27.3	6.2	7.9	12.5	7.1
44.0	16.5	23.3	8.2	16.0	24.6	7.5	15.5	26.0	6.9	15.0	27.5	6.3	8.2	12.5	7.3
45.0	16.8	23.4	8.3	16.3	24.7	7.6	15.8	26.1	7.0	15.3	27.6	6.4	8.4	12.6	7.4
46.0	17	23.5	8.4	16.5	24.8	7.7	16.0	26.2	7.1	15.5	27.7	6.5	8.5	12.6	7.5
48.0	17.6	23.7	8.5	17.1	25.0	7.9	16.5	26.4	7.2	16.0	27.9	6.6	8.8	12.7	7.7
50.0	18.1	23.9	8.7	17.6	25.2	8.0	17.0	26.6	7.4	16.5	28.1	6.8	9.1	12.7	7.9

NOTES:

1. kW = Compressor Input Power
2. EER = Chiller EER (includes power from compressors, fans, and the control panels 0.8 kW)
3. LCWT = Leaving Chilled Water Temperature
4. Ratings are based upon 2.4 GPM cooler water per ton and 0.0001 fouling factor
5. Rated in accordance with ARI Standard 550/590-98
6. The shaded points are certified in accordance with ARI Standard 550/590-98

Ratings - R-22 (60Hz - English Units) - Cont.

MODEL:YCAL0025EC **IPLV=13.0**

AIR TEMPERATURE ON - CONDENSER (°F)

LCWT (°F)	75.0			80.0			85.0			90.0			95.0			100.0		
	TONS	KW	EER	TONS	KW	EER	TONS	KW	EER	TONS	KW	EER	TONS	KW	EER	TONS	KW	EER
40.0	22.1	19.5	11.8	21.7	20.5	11.1	21.3	21.5	10.4	20.8	22.7	9.7	20.3	23.9	9.1	19.8	25.2	8.4
42.0	22.9	19.6	12.1	22.4	20.6	11.4	22.0	21.7	10.7	21.5	22.8	10.0	21.0	24.0	9.3	20.5	25.3	8.7
44.0	23.6	19.8	12.5	23.2	20.7	11.7	22.7	21.8	11.0	22.2	22.9	10.3	21.7	24.1	9.6	21.2	25.4	8.9
45.0	24.0	19.8	12.6	23.6	20.8	11.9	23.1	21.8	11.2	22.6	23.0	10.4	22.1	24.2	9.7	21.5	25.5	9.1
46.0	24.4	19.9	12.8	24.0	20.9	12.0	23.5	21.9	11.3	23.0	23.0	10.6	22.4	24.2	9.9	21.9	25.5	9.2
48.0	25.2	20.0	13.2	24.7	21.0	12.4	24.2	22.0	11.6	23.7	23.1	10.9	23.2	24.4	10.2	22.6	25.7	9.5
50.0	26.1	20.1	13.5	25.5	21.1	12.7	25.0	22.1	11.9	24.5	23.3	11.2	23.9	24.5	10.4	23.3	25.8	9.7

MODEL:YCAL0027EC **IPLV=13.4**

AIR TEMPERATURE ON - CONDENSER (°F)

LCWT (°F)	75.0			80.0			85.0			90.0			95.0			100.0		
	TONS	KW	EER	TONS	KW	EER	TONS	KW	EER	TONS	KW	EER	TONS	KW	EER	TONS	KW	EER
40.0	24.4	21.5	12.0	23.9	22.6	11.2	23.4	23.8	10.5	22.9	25.2	9.8	22.4	26.6	9.1	21.8	28.1	8.4
42.0	25.2	21.6	12.3	24.7	22.8	11.5	24.2	24.0	10.8	23.7	25.3	10.0	23.1	26.8	9.3	22.6	28.3	8.7
44.0	26.1	21.7	12.6	25.6	22.9	11.8	25.0	24.2	11.1	24.5	25.5	10.3	23.9	26.9	9.6	23.3	28.4	8.9
45.0	26.5	21.8	12.8	26.0	23.0	12.0	25.4	24.2	11.2	24.9	25.6	10.5	24.3	27.0	9.7	23.7	28.5	9.0
46.0	26.9	21.9	13.0	26.4	23.1	12.2	25.9	24.3	11.4	25.3	25.6	10.6	24.7	27.1	9.9	24.1	28.6	9.2
48.0	27.8	22.1	13.3	27.3	23.2	12.5	26.7	24.5	11.7	26.1	25.8	10.9	25.5	27.2	10.1	24.9	28.8	9.4
50.0	28.7	22.2	13.6	28.1	23.4	12.8	27.5	24.6	12.0	26.9	26.0	11.2	26.3	27.4	10.4	25.7	28.9	9.7

MODEL:YCAL0032EC **IPLV=13.7**

AIR TEMPERATURE ON - CONDENSER (°F)

LCWT (°F)	75.0			80.0			85.0			90.0			95.0			100.0		
	TONS	KW	EER	TONS	KW	EER	TONS	KW	EER	TONS	KW	EER	TONS	KW	EER	TONS	KW	EER
40.0	28.7	25.2	12.2	28.1	26.6	11.4	27.5	28.1	10.6	26.9	29.8	9.8	26.2	31.5	9.1	25.6	33.3	8.5
42.0	29.6	25.4	12.5	29.0	26.8	11.7	28.4	28.4	10.9	27.7	30.0	10.1	27.1	31.7	9.4	26.4	33.5	8.7
44.0	30.6	25.6	12.8	30.0	27.0	12.0	29.3	28.6	11.1	28.7	30.2	10.4	28.0	32.0	9.6	27.3	33.8	8.9
45.0	31.1	25.7	13.0	30.5	27.1	12.1	29.8	28.7	11.3	29.1	30.3	10.5	28.4	32.1	9.7	27.7	33.9	9.0
46.0	31.6	25.8	13.2	30.9	27.3	12.3	30.3	28.8	11.4	29.6	30.5	10.6	28.9	32.2	9.8	28.2	34.1	9.1
48.0	32.6	26.0	13.5	31.9	27.5	12.6	31.2	29.0	11.7	30.5	30.7	10.9	29.8	32.5	10.1	29.1	34.3	9.4
50.0	33.6	26.3	13.8	32.9	27.7	12.9	32.2	29.3	12.0	31.5	30.9	11.1	30.8	32.7	10.3	30.0	34.6	9.6

NOTES:

1. kW = Compressor Input Power
2. EER = Chiller EER (includes power from compressors, fans, and the control panels 0.8 kW)
3. LCWT = Leaving Chilled Water Temperature
4. Ratings are based upon 2.4 GPM cooler water per ton and 0.0001 fouling factor
5. Rated in accordance with ARI Standard 550/590-98
6. The shaded points are certified in accordance with ARI Standard 550/590-98

MODEL: YCAL0025EC **IPLV=13.0****AIR TEMPERATURE ON - CONDENSER (°F)**

LCWT (°F)	105			110.0			115.0			120.0			125.0		
	TONS	KW	EER	TONS	KW	EER	TONS	KW	EER	TONS	KW	EER	TONS	KW	EER
40.0	19.3	26.6	7.8	18.7	28.0	7.2	18.1	29.6	6.7	17.5	31.2	6.1	16.8	32.9	5.6
42.0	19.9	26.7	8.1	19.4	28.2	7.4	18.7	29.7	6.9	18.1	31.4	6.3	17.5	33.1	5.8
44.0	20.6	26.8	8.3	20.0	28.3	7.7	19.4	29.9	7.1	18.8	31.5	6.5	18.1	33.2	6.0
45.0	21	26.9	8.4	20.4	28.4	7.8	19.7	29.9	7.2	19.1	31.6	6.6	18.4	33.3	6.1
46.0	21.3	26.9	8.5	20.7	28.4	7.9	20.1	30.0	7.3	19.4	31.7	6.7	18.7	33.4	6.2
48.0	22	27.1	8.8	21.4	28.6	8.1	20.8	30.1	7.5	20.1	31.8	6.9	19.4	33.6	6.4
50.0	22.7	27.2	9.0	22.1	28.7	8.4	21.5	30.3	7.7	20.8	31.9	7.1	20.1	33.7	6.6

MODEL: YCAL0027EC **IPLV=13.4****AIR TEMPERATURE ON - CONDENSER (°F)**

LCWT (°F)	105			110.0			115.0			120.0			125.0		
	TONS	KW	EER	TONS	KW	EER	TONS	KW	EER	TONS	KW	EER	TONS	KW	EER
40.0	21.2	29.7	7.8	20.6	31.4	7.2	20.0	33.1	6.7	19.4	34.9	6.1	18.7	36.9	5.6
42.0	22	29.9	8.0	21.4	31.5	7.4	20.7	33.3	6.8	20.1	35.1	6.3	19.4	37.1	5.8
44.0	22.7	30.0	8.3	22.1	31.7	7.6	21.4	33.5	7.0	20.8	35.4	6.5	20.1	37.3	6.0
45.0	23.1	30.1	8.4	22.5	31.8	7.7	21.8	33.6	7.1	21.1	35.5	6.6	20.4	37.4	6.1
46.0	23.5	30.2	8.5	22.8	31.9	7.8	22.2	33.7	7.2	21.5	35.6	6.7	20.8	37.5	6.1
48.0	24.2	30.4	8.7	23.6	32.1	8.1	22.9	33.9	7.4	22.2	35.8	6.9	21.5	37.7	6.3
50.0	25	30.6	9.0	24.4	32.3	8.3	23.6	34.1	7.7	22.9	36.0	7.1	22.2	38.0	6.5

MODEL: YCAL0032EC **IPLV=13.7****AIR TEMPERATURE ON - CONDENSER (°F)**

LCWT (°F)	105			110.0			115.0			120.0			125.0		
	TONS	KW	EER	TONS	KW	EER	TONS	KW	EER	TONS	KW	EER	TONS	KW	EER
40.0	24.9	35.2	7.8	24.2	37.2	7.2	23.5	39.2	6.7	12.5	18.4	7.0	12.2	19.5	6.5
42.0	25.7	35.4	8.0	25.0	37.4	7.4	24.3	39.5	6.9	13.0	18.5	7.3	12.6	19.6	6.7
44.0	26.6	35.7	8.2	25.8	37.7	7.6	25.1	39.8	7.0	13.5	18.6	7.5	13.0	19.7	6.9
45.0	27	35.8	8.3	26.3	37.9	7.7	25.5	40.0	7.1	13.7	18.6	7.6	13.3	19.7	7.0
46.0	27.5	36.0	8.5	26.7	38.0	7.8	14.4	17.7	8.3	13.9	18.7	7.7	13.5	19.8	7.1
48.0	28.3	36.2	8.7	27.6	38.3	8.0	14.8	17.7	8.6	14.4	18.8	7.9	14.0	19.9	7.3
50.0	29.2	36.5	8.9	28.4	38.6	8.2	15.3	17.8	8.8	14.9	18.9	8.2	14.4	20.0	7.5

NOTES:

1. kW = Compressor Input Power
2. EER = Chiller EER (includes power from compressors, fans, and the control panels 0.8 kW)
3. LCWT = Leaving Chilled Water Temperature
4. Ratings are based upon 2.4 GPM cooler water per ton and 0.0001 fouling factor
5. Rated in accordance with ARI Standard 550/590-98
6. The shaded points are certified in accordance with ARI Standard 550/590-98

Ratings - R-22 (60Hz - English Units) - Cont.

MODEL: YCAL0041EC **IPLV=13.9**

AIR TEMPERATURE ON - CONDENSER (°F)

LCWT (°F)	75.0			80.0			85.0			90.0			95.0			100.0		
	TONS	KW	EER	TONS	KW	EER	TONS	KW	EER	TONS	KW	EER	TONS	KW	EER	TONS	KW	EER
40.0	35.8	30.3	12.0	35.1	32.0	11.2	34.4	33.8	10.5	33.7	35.7	9.8	32.9	37.7	9.1	32.1	39.9	8.5
42.0	37.0	30.6	12.3	36.2	32.2	11.5	35.5	34.0	10.8	34.8	35.9	10.0	34.0	38.0	9.4	33.2	40.1	8.7
44.0	38.1	30.8	12.6	37.4	32.5	11.8	36.7	34.3	11.0	35.9	36.2	10.3	35.1	38.2	9.6	34.3	40.4	8.9
45.0	38.7	31.0	12.7	38.0	32.6	11.9	37.2	34.4	11.2	36.4	36.3	10.4	35.6	38.4	9.7	34.8	40.6	9.0
46.0	39.3	31.1	12.9	38.6	32.8	12.1	37.8	34.5	11.3	37.0	36.5	10.6	36.2	38.5	9.8	35.3	40.7	9.2
48.0	40.6	31.4	13.2	39.8	33.0	12.4	39.0	34.8	11.6	38.2	36.7	10.8	37.3	38.8	10.1	36.5	41.0	9.4
50.0	41.8	31.7	13.5	41.0	33.3	12.6	40.2	35.1	11.8	39.4	37.0	11.1	38.5	39.1	10.3	37.6	41.2	9.6

MODEL: YCAL0045EC **IPLV=14.0**

AIR TEMPERATURE ON - CONDENSER (°F)

LCWT (°F)	75.0			80.0			85.0			90.0			95.0			100.0		
	TONS	KW	EER	TONS	KW	EER	TONS	KW	EER	TONS	KW	EER	TONS	KW	EER	TONS	KW	EER
40.0	39.0	33.4	12.0	38.1	35.1	11.2	37.2	37.0	10.5	36.3	39.0	9.8	35.4	41.2	9.1	34.4	43.5	8.4
42.0	40.3	33.7	12.3	39.3	35.4	11.5	38.4	37.3	10.8	37.5	39.3	10.0	36.6	41.5	9.3	35.6	43.8	8.7
44.0	41.5	34.0	12.6	40.6	35.7	11.8	39.7	37.6	11.0	38.7	39.6	10.3	37.8	41.8	9.6	36.8	44.1	8.9
45.0	42.2	34.1	12.7	41.2	35.9	11.9	40.3	37.7	11.2	39.3	39.8	10.4	38.4	41.9	9.7	37.4	44.2	9.0
46.0	42.8	34.3	12.9	41.9	36.0	12.1	40.9	37.9	11.3	40.0	39.9	10.5	39.0	42.1	9.8	38.0	44.4	9.1
48.0	44.1	34.6	13.2	43.2	36.4	12.3	42.2	38.2	11.6	41.2	40.3	10.8	40.2	42.4	10.1	39.2	44.7	9.4
50.0	45.5	35.0	13.4	44.5	36.7	12.6	43.5	38.6	11.8	42.5	40.6	11.0	41.5	42.8	10.3	40.5	45.1	9.6

MODEL: YCAL0051EC **IPLV=14.3**

AIR TEMPERATURE ON - CONDENSER (°F)

LCWT (°F)	75.0			80.0			85.0			90.0			95.0			100.0		
	TONS	KW	EER	TONS	KW	EER	TONS	KW	EER	TONS	KW	EER	TONS	KW	EER	TONS	KW	EER
40.0	45.0	38.9	12.1	43.9	41.0	11.3	42.8	43.2	10.5	41.8	45.6	9.8	40.7	48.1	9.1	39.7	50.8	8.4
42.0	46.4	39.2	12.4	45.4	41.3	11.6	44.3	43.5	10.8	43.2	45.9	10.1	42.1	48.4	9.4	41.1	51.1	8.7
44.0	47.9	39.5	12.8	46.9	41.6	11.9	45.8	43.8	11.1	44.7	46.2	10.4	43.6	48.7	9.6	42.5	51.4	8.9
45.0	48.7	39.7	12.9	47.6	41.7	12.1	46.5	43.9	11.3	45.4	46.3	10.5	44.3	48.9	9.8	43.2	51.6	9.1
46.0	49.5	39.8	13.1	48.4	41.9	12.2	47.2	44.1	11.4	46.1	46.5	10.6	45.0	49.0	9.9	43.9	51.7	9.2
48.0	51.0	40.1	13.4	49.9	42.2	12.5	48.8	44.4	11.7	47.6	46.8	10.9	46.5	49.3	10.2	45.3	52.1	9.4
50.0	52.6	40.5	13.7	51.4	42.5	12.8	50.3	44.7	12.0	49.1	47.1	11.2	48.0	49.7	10.4	46.8	52.4	9.7

NOTES:

1. kW = Compressor Input Power
2. EER = Chiller EER (includes power from compressors, fans, and the control panels 0.8 kW)
3. LCWT = Leaving Chilled Water Temperature
4. Ratings are based upon 2.4 GPM cooler water per ton and 0.0001 fouling factor
5. Rated in accordance with ARI Standard 550/590-98
6. The shaded points are certified in accordance with ARI Standard 550/590-98

MODEL: YCAL0041EC **IPLV=13.9****AIR TEMPERATURE ON - CONDENSER (°F)**

LCWT (°F)	105			110.0			115.0			120.0			125.0		
	TONS	KW	EER	TONS	KW	EER	TONS	KW	EER	TONS	KW	EER	TONS	KW	EER
40.0	31.3	42.2	7.9	30.5	44.7	7.3	29.6	47.4	6.7	28.7	50.2	6.2	27.8	53.2	5.7
42.0	32.4	42.5	8.1	31.5	45.0	7.5	30.6	47.6	6.9	29.7	50.4	6.4	28.7	53.4	5.8
44.0	33.4	42.7	8.3	32.5	45.2	7.7	31.6	47.9	7.1	30.7	50.7	6.5	29.7	53.7	6.0
45.0	34.0	42.9	8.4	33.1	45.3	7.8	32.1	48.0	7.2	31.2	50.8	6.6	30.2	53.8	6.1
46.0	34.5	43.0	8.5	33.6	45.5	7.9	32.7	48.1	7.3	31.7	50.9	6.7	30.7	53.9	6.2
48.0	35.6	43.3	8.7	34.7	45.7	8.1	33.7	48.4	7.5	32.8	51.2	6.9	31.8	54.1	6.4
50.0	36.7	43.6	9.0	35.8	46.0	8.3	34.8	48.6	7.7	33.8	51.4	7.1	32.8	54.4	6.6

MODEL: YCAL0045EC **IPLV=14.0****AIR TEMPERATURE ON - CONDENSER (°F)**

LCWT (°F)	105			110.0			115.0			120.0			125.0		
	TONS	KW	EER	TONS	KW	EER	TONS	KW	EER	TONS	KW	EER	TONS	KW	EER
40.0	33.5	45.9	7.8	32.5	48.6	7.2	31.5	51.4	6.6	30.4	54.4	6.1	29.3	57.5	5.6
42.0	34.6	46.2	8.0	33.6	48.9	7.4	32.6	51.7	6.8	31.5	54.7	6.3	30.4	57.8	5.7
44.0	35.8	46.5	8.2	34.8	49.2	7.6	33.7	52.0	7.0	32.6	55.0	6.5	31.5	58.1	5.9
45.0	36.4	46.7	8.4	35.4	49.4	7.7	34.3	52.1	7.1	33.2	55.1	6.6	32.0	58.3	6.0
46.0	37.0	46.9	8.5	36.0	49.5	7.8	34.9	52.3	7.2	33.8	55.3	6.7	32.6	58.5	6.1
48.0	38.2	47.2	8.7	37.2	49.8	8.0	36.0	52.7	7.4	34.9	55.6	6.8	33.7	58.8	6.3
50.0	39.4	47.6	8.9	38.4	50.2	8.3	37.2	53.0	7.6	36.1	56.0	7.0	34.9	59.1	6.5

MODEL: YCAL0051EC **IPLV=14.3****AIR TEMPERATURE ON - CONDENSER (°F)**

LCWT (°F)	105			110.0			115.0			120.0			125.0		
	TONS	KW	EER	TONS	KW	EER	TONS	KW	EER	TONS	KW	EER	TONS	KW	EER
40.0	38.6	53.7	7.8	37.5	56.7	7.2	36.3	59.9	6.7	35.1	63.3	6.1	33.9	66.8	5.6
42.0	39.9	54.0	8.0	38.8	57.0	7.4	37.6	60.2	6.9	36.4	63.6	6.3	35.1	67.2	5.8
44.0	41.3	54.3	8.3	40.1	57.4	7.7	38.9	60.6	7.1	37.7	64.0	6.5	36.4	67.6	6.0
45.0	42.0	54.5	8.4	40.8	57.5	7.8	39.6	60.8	7.2	38.3	64.2	6.6	37.0	67.8	6.1
46.0	42.7	54.6	8.5	41.5	57.7	7.9	40.3	60.9	7.3	39.0	64.4	6.7	37.7	68.0	6.1
48.0	44.1	55.0	8.7	42.9	58.0	8.1	41.6	61.3	7.5	40.3	64.7	6.9	39.0	68.3	6.3
50.0	45.6	55.3	9.0	44.3	58.4	8.3	43.0	61.7	7.7	41.7	65.1	7.1	40.3	68.7	6.5

NOTES:

1. kW = Compressor Input Power
2. EER = Chiller EER (includes power from compressors, fans, and the control panels 0.8 kW)
3. LCWT = Leaving Chilled Water Temperature
4. Ratings are based upon 2.4 GPM cooler water per ton and 0.0001 fouling factor
5. Rated in accordance with ARI Standard 550/590-98
6. The shaded points are certified in accordance with ARI Standard 550/590-98

Ratings - R-22 (60Hz - English Units) - Cont.

MODEL: YCAL0055EC **IPLV=13.6**

AIR TEMPERATURE ON - CONDENSER (°F)

LCWT (°F)	75.0			80.0			85.0			90.0			95.0			100.0		
	TONS	KW	EER	TONS	KW	EER	TONS	KW	EER	TONS	KW	EER	TONS	KW	EER	TONS	KW	EER
40.0	48.6	42.1	11.9	47.6	44.4	11.2	46.6	46.8	10.5	45.6	49.4	9.7	44.6	52.2	9.1	43.5	55.1	8.4
42.0	50.2	42.4	12.3	49.2	44.7	11.5	48.2	47.1	10.7	47.1	49.7	10.0	46.1	52.5	9.3	44.9	55.4	8.7
44.0	51.8	42.7	12.6	50.8	44.9	11.8	49.8	47.4	11.0	48.7	50.0	10.3	47.6	52.8	9.6	46.4	55.7	8.9
45.0	52.7	42.8	12.8	51.6	45.1	12.0	50.6	47.5	11.2	49.5	50.2	10.4	48.4	52.9	9.7	47.2	55.9	9.0
46.0	53.5	43.0	12.9	52.5	45.2	12.1	51.4	47.7	11.3	50.3	50.3	10.6	49.1	53.1	9.9	48.0	56.1	9.2
48.0	55.2	43.3	13.3	54.2	45.5	12.4	53.1	48.0	11.6	51.9	50.6	10.9	50.7	53.4	10.1	49.5	56.4	9.4
50.0	57.0	43.6	13.6	55.9	45.9	12.8	54.7	48.3	11.9	53.6	50.9	11.2	52.4	53.7	10.4	51.1	56.7	9.7

MODEL: YCAL0061EC **IPLV=14.2**

AIR TEMPERATURE ON - CONDENSER (°F)

LCWT (°F)	75.0			80.0			85.0			90.0			95.0			100.0		
	TONS	KW	EER	TONS	KW	EER	TONS	KW	EER	TONS	KW	EER	TONS	KW	EER	TONS	KW	EER
40.0	56.8	49.8	12.1	55.6	52.6	11.3	54.5	55.5	10.5	53.3	58.7	9.8	52.0	62.0	9.1	50.8	65.5	8.4
42.0	58.7	50.2	12.4	57.5	53.0	11.5	56.3	56.0	10.8	55.0	59.1	10.0	53.8	62.5	9.3	52.5	66.0	8.7
44.0	60.6	50.6	12.7	59.4	53.4	11.8	58.1	56.4	11.0	56.9	59.6	10.3	55.6	62.9	9.6	54.2	66.5	8.9
45.0	61.5	50.9	12.8	60.3	53.6	12.0	59.1	56.6	11.2	57.8	59.8	10.4	56.5	63.2	9.7	55.1	66.7	9.0
46.0	62.5	51.1	13.0	61.3	53.9	12.1	60.0	56.8	11.3	58.7	60.0	10.6	57.4	63.4	9.8	56.0	67.0	9.1
48.0	64.5	51.5	13.3	63.2	54.3	12.4	61.9	57.3	11.6	60.6	60.5	10.8	59.2	63.9	10.1	57.8	67.5	9.4
50.0	66.5	52.0	13.6	65.2	54.8	12.7	63.9	57.8	11.9	62.5	61.0	11.1	61.1	64.4	10.3	59.7	68.0	9.6

MODEL: YCAL0065EC **IPLV=14.5**

AIR TEMPERATURE ON - CONDENSER (°F)

LCWT (°F)	75.0			80.0			85.0			90.0			95.0			100.0		
	TONS	KW	EER	TONS	KW	EER	TONS	KW	EER	TONS	KW	EER	TONS	KW	EER	TONS	KW	EER
40.0	&	&	&	&	&	&	59.9	61.4	10.6	58.5	64.8	9.8	57.2	68.4	9.1	55.8	72.2	8.5
42.0	64.5	55.7	12.4	63.2	58.7	11.6	61.8	61.9	10.8	60.5	65.3	10.1	59.1	68.9	9.4	57.6	72.8	8.7
44.0	66.5	56.2	12.7	65.2	59.2	11.9	63.9	62.5	11.1	62.5	65.9	10.3	61.0	69.5	9.6	59.6	73.4	8.9
45.0	67.6	56.5	12.8	66.3	59.5	12.0	64.9	62.7	11.2	63.5	66.2	10.4	62.0	69.8	9.7	60.5	73.7	9.0
46.0	68.7	56.8	13.0	67.3	59.8	12.1	65.9	63.0	11.3	64.5	66.5	10.6	63.0	70.1	9.8	61.5	74.0	9.1
48.0	70.8	57.3	13.3	69.5	60.4	12.4	68.0	63.6	11.6	66.5	67.1	10.8	65.0	70.8	10.1	63.5	74.7	9.4
50.0	73.1	57.9	13.6	71.6	61.0	12.7	70.2	64.2	11.9	68.7	67.7	11.1	67.1	71.4	10.3	65.5	75.3	9.6

NOTES:

1. kW = Compressor Input Power
2. EER = Chiller EER (includes power from compressors, fans, and the control panels 0.8 kW)
3. LCWT = Leaving Chilled Water Temperature
4. Ratings are based upon 2.4 GPM cooler water per ton and 0.0001 fouling factor
5. Rated in accordance with ARI Standard 550/590-98
6. The shaded points are certified in accordance with ARI Standard 550/590-98

MODEL: YCAL0055EC **IPLV=13.6****AIR TEMPERATURE ON - CONDENSER (°F)**

LCWT (°F)	105			110.0			115.0			120.0			125.0		
	TONS	KW	EER	TONS	KW	EER	TONS	KW	EER	TONS	KW	EER	TONS	KW	EER
40.0	42.3	58.2	7.8	41.2	61.4	7.2	39.9	64.8	6.7	29.0	48.0	6.4	28.0	50.6	5.9
42.0	43.8	58.5	8.1	42.6	61.8	7.5	41.3	65.2	6.9	30.0	48.3	6.6	29.0	50.9	6.0
44.0	45.3	58.8	8.3	44.0	62.1	7.7	42.7	65.6	7.1	31.1	48.5	6.8	30.1	51.2	6.2
45.0	46.0	59.0	8.4	44.7	62.3	7.8	43.4	65.8	7.2	31.6	48.6	6.9	30.6	51.3	6.3
46.0	46.8	59.1	8.5	45.5	62.5	7.9	44.2	65.9	7.3	32.2	48.7	7.0	31.1	51.4	6.4
48.0	48.3	59.5	8.8	47.0	62.8	8.1	45.6	66.3	7.5	33.3	49.0	7.2	32.2	51.7	6.6
50.0	49.8	59.9	9.0	48.5	63.2	8.3	47.1	66.7	7.7	34.4	49.2	7.4	33.3	51.9	6.8

MODEL: YCAL0061EC **IPLV=14.2****AIR TEMPERATURE ON - CONDENSER (°F)**

LCWT (°F)	105			110.0			115.0			120.0			125.0		
	TONS	KW	EER	TONS	KW	EER	TONS	KW	EER	TONS	KW	EER	TONS	KW	EER
40.0	49.5	69.2	7.8	48.2	73.1	7.2	46.8	77.2	6.7	45.4	81.5	6.2	34.7	63.9	5.9
42.0	51.1	69.7	8.0	49.8	73.6	7.4	48.4	77.8	6.9	46.9	82.1	6.3	35.9	64.3	6.1
44.0	52.9	70.2	8.2	51.5	74.1	7.6	50.0	78.3	7.1	48.5	82.7	6.5	37.2	64.7	6.2
45.0	53.7	70.5	8.4	52.3	74.4	7.7	50.9	78.6	7.2	49.3	83.0	6.6	37.8	64.9	6.3
46.0	54.6	70.7	8.5	53.2	74.7	7.8	51.7	78.9	7.2	50.2	83.3	6.7	38.5	65.1	6.4
48.0	56.4	71.3	8.7	54.9	75.3	8.0	53.4	79.4	7.4	51.8	83.9	6.9	39.8	65.6	6.6
50.0	58.2	71.8	8.9	56.7	75.8	8.2	55.1	80.0	7.6	53.5	84.5	7.0	41.1	66.0	6.8

MODEL: YCAL0065EC **IPLV=14.5****AIR TEMPERATURE ON - CONDENSER (°F)**

LCWT (°F)	105			110.0			115.0			120.0			125.0		
	TONS	KW	EER	TONS	KW	EER	TONS	KW	EER	TONS	KW	EER	TONS	KW	EER
40.0	54.3	76.3	7.9	52.8	80.6	7.3	51.3	85.1	6.7	49.7	89.9	6.2	38.2	73.1	5.7
42.0	56.2	76.9	8.1	54.6	81.2	7.5	53.1	85.8	6.9	51.4	90.6	6.3	39.6	73.6	5.9
44.0	58.0	77.5	8.3	56.5	81.9	7.6	54.9	86.5	7.1	53.2	91.3	6.5	28.9	42.9	7.0
45.0	59.0	77.8	8.4	57.4	82.2	7.7	55.8	86.8	7.2	54.1	91.7	6.6	29.4	43.1	7.1
46.0	59.9	78.2	8.5	58.3	82.5	7.8	56.7	87.2	7.2	55.0	92.1	6.7	29.9	43.2	7.2
48.0	61.9	78.8	8.7	60.3	83.2	8.0	58.6	87.9	7.4	56.8	92.8	6.8	31.0	43.4	7.4
50.0	63.9	79.5	8.9	62.2	83.9	8.2	60.5	88.6	7.6	58.7	93.5	7.0	32.0	43.6	7.6

NOTES:

1. kW = Compressor Input Power
2. EER = Chiller EER (includes power from compressors, fans, and the control panels 0.8 kW)
3. LCWT = Leaving Chilled Water Temperature
4. Ratings are based upon 2.4 GPM cooler water per ton and 0.0001 fouling factor
5. Rated in accordance with ARI Standard 550/590-98
6. The shaded points are certified in accordance with ARI Standard 550/590-98

Ratings - R-22 (60Hz - SI Units)

MODEL: YCAL0012EC

AIR TEMPERATURE ON - CONDENSER (°C)

LCWT (°C)	25.0			30.0			35.0			40.0			45.0			50.0		
	KW	KW	COP	KW	KW	COP	KW	KW	COP	KW	KW	COP	KW	KW	COP	KW	KW	COP
5.0	35.2	9.0	3.5	33.9	10.0	3.1	32.5	11.0	2.7	31.1	12.2	2.4	29.6	13.6	2.0	27.9	15.2	1.7
6.0	36.3	9.0	3.6	34.9	10.0	3.2	33.5	11.1	2.8	32.0	12.3	2.4	30.5	13.7	2.1	28.8	15.2	1.8
7.0	37.4	9.1	3.7	36.0	10.1	3.2	34.5	11.2	2.8	33.0	12.4	2.5	31.4	13.7	2.1	29.7	15.3	1.8
8.0	38.5	9.2	3.8	37.0	10.2	3.3	35.5	11.2	2.9	34.0	12.5	2.5	32.4	13.8	2.2	30.6	15.4	1.9
9.0	39.6	9.2	3.9	38.1	10.2	3.4	36.6	11.3	3.0	35.0	12.5	2.6	33.3	13.9	2.2	31.5	15.5	1.9
10.0	40.7	9.3	4.0	39.2	10.3	3.5	37.6	11.4	3.0	36.0	12.6	2.6	34.3	14.0	2.3	32.4	15.5	2.0
11.0	41.9	9.4	4.0	40.3	10.4	3.5	38.7	11.5	3.1	37.1	12.7	2.7	35.3	14.1	2.3	33.4	15.6	2.0

MODEL: YCAL0018EC

AIR TEMPERATURE ON - CONDENSER (°C)

LCWT (°C)	25.0			30.0			35.0			40.0			45.0			50.0		
	KW	KW	COP	KW	KW	COP	KW	KW	COP	KW	KW	COP	KW	KW	COP	KW	KW	COP
5.0	52.9	14.0	3.5	50.8	15.4	3.1	48.6	16.9	2.7	46.3	18.7	2.4	43.9	20.6	2.0	41.4	22.8	1.7
6.0	54.5	14.1	3.6	52.3	15.5	3.2	50.1	17.1	2.8	47.7	18.8	2.4	45.2	20.8	2.1	42.7	22.9	1.8
7.0	56.1	14.3	3.7	53.9	15.6	3.2	51.6	17.2	2.8	49.1	18.9	2.5	46.6	20.9	2.1	44.0	23.1	1.8
8.0	57.7	14.4	3.8	55.4	15.8	3.3	53.1	17.3	2.9	50.6	19.1	2.5	48.0	21.0	2.2	45.3	23.2	1.9
9.0	59.4	14.5	3.8	57.0	15.9	3.4	54.6	17.5	3.0	52.0	19.2	2.6	49.4	21.2	2.2	46.6	23.4	1.9
10.0	61.0	14.7	3.9	58.6	16.1	3.4	56.1	17.6	3.0	53.5	19.4	2.6	50.8	21.4	2.3	48.0	23.6	2.0
11.0	62.7	14.8	4.0	60.3	16.2	3.5	57.7	17.8	3.1	55.1	19.5	2.7	52.3	21.5	2.3	49.6	23.8	2.1

MODEL: YCAL0021EC

AIR TEMPERATURE ON - CONDENSER (°C)

LCWT (°C)	25.0			30.0			35.0			40.0			45.0			50.0		
	KW	KW	COP	KW	KW	COP	KW	KW	COP	KW	KW	COP	KW	KW	COP	KW	KW	COP
5.0	63.8	16.8	3.6	61.2	18.5	3.1	58.5	20.5	2.7	55.7	22.7	2.4	52.7	25.1	2.0	49.6	27.8	1.7
6.0	65.6	16.9	3.7	62.9	18.7	3.2	60.2	20.7	2.8	57.3	22.9	2.4	54.3	25.3	2.1	51.1	28.0	1.8
7.0	67.4	17.1	3.7	64.7	18.9	3.3	61.9	20.8	2.8	58.9	23.1	2.5	55.8	25.5	2.1	52.8	28.2	1.8
8.0	69.2	17.3	3.8	66.5	19.0	3.3	63.6	21.0	2.9	60.6	23.2	2.5	57.4	25.7	2.2	54.5	28.4	1.9
9.0	71.1	17.4	3.9	68.3	19.2	3.4	65.3	21.2	2.9	62.3	23.4	2.6	59.1	25.9	2.2	56.2	28.6	1.9
10.0	73.0	17.6	3.9	70.1	19.4	3.4	67.1	21.4	3.0	64.0	23.6	2.6	60.7	26.1	2.2	58.0	28.8	2.0
11.0	74.9	17.8	4.0	72.0	19.6	3.5	68.9	21.6	3.1	65.7	23.8	2.7	62.3	26.3	2.3	59.8	29.0	2.0

NOTES:

1. kW = Compressor Input Power
2. EER = Chiller EER (includes power from compressors, fans, and the control panels 0.8 kW)
3. LCWT = Leaving Chilled Water Temperature
4. Ratings are based upon 2.4 GPM cooler water per ton and 0.0001 fouling factor
5. Rated in accordance with ARI Standard 550/590-98
6. The shaded points are certified in accordance with ARI Standard 550/590-98

MODEL: YCAL0025EC**AIR TEMPERATURE ON - CONDENSER (°C)**

LCWT (°C)	25.0			30.0			35.0			40.0			45.0			50.0		
	KW	KW	COP	KW	KW	COP	KW	KW	COP	KW	KW	COP	KW	KW	COP	KW	KW	COP
5.0	78.5	20.0	3.4	75.7	21.8	3.1	72.6	24.0	2.7	69.3	26.4	2.4	65.6	29.0	2.1	61.7	32.0	1.8
6.0	80.9	20.1	3.5	78.0	21.9	3.1	74.8	24.1	2.8	71.4	26.5	2.4	67.7	29.1	2.1	63.7	32.1	1.8
7.0	83.3	20.2	3.6	80.3	22.0	3.2	77.1	24.2	2.8	73.6	26.6	2.5	69.8	29.3	2.2	65.8	32.2	1.9
8.0	85.8	20.3	3.7	82.7	22.1	3.3	79.4	24.3	2.9	75.8	26.7	2.6	72.0	29.4	2.2	67.8	32.4	1.9
9.0	88.3	20.4	3.8	85.2	22.2	3.4	81.8	24.4	3.0	78.1	26.8	2.6	74.2	29.5	2.3	70.0	32.5	2.0
10.0	90.9	20.5	3.9	87.6	22.4	3.5	84.1	24.5	3.1	80.4	26.9	2.7	76.4	29.6	2.3	72.1	32.6	2.0
11.0	93.5	20.6	4.0	90.2	22.5	3.5	86.6	24.6	3.1	82.7	27.0	2.8	78.7	29.7	2.4	74.3	32.8	2.1

MODEL: YCAL0027EC**AIR TEMPERATURE ON - CONDENSER (°C)**

LCWT (°C)	25.0			30.0			35.0			40.0			45.0			50.0		
	KW	KW	COP	KW	KW	COP	KW	KW	COP	KW	KW	COP	KW	KW	COP	KW	KW	COP
5.0	86.6	22.0	3.5	83.5	24.2	3.1	80.0	26.7	2.7	76.4	29.4	2.4	72.5	32.5	2.0	68.4	35.8	1.8
6.0	89.2	22.1	3.6	85.9	24.3	3.1	82.5	26.8	2.8	78.7	29.6	2.4	74.8	32.7	2.1	70.6	36.0	1.8
7.0	91.9	22.2	3.6	88.5	24.5	3.2	84.9	27.0	2.8	81.1	29.8	2.5	77.1	32.8	2.2	72.8	36.2	1.9
8.0	94.6	22.4	3.7	91.1	24.6	3.3	87.5	27.1	2.9	83.5	29.9	2.5	79.4	33.0	2.2	75.0	36.4	1.9
9.0	97.3	22.5	3.8	93.8	24.8	3.4	90.0	27.2	3.0	86.0	30.1	2.6	81.7	33.2	2.3	77.3	36.6	2.0
10.0	100.1	22.7	3.9	96.4	24.9	3.5	92.6	27.4	3.1	88.5	30.2	2.7	84.2	33.3	2.3	79.6	36.8	2.0
11.0	102.9	22.8	4.0	99.2	25.1	3.5	95.2	27.6	3.1	91.0	30.4	2.7	86.6	33.5	2.4	81.9	37.0	2.1

MODEL: YCAL0032EC**AIR TEMPERATURE ON - CONDENSER (°C)**

LCWT (°C)	25.0			30.0			35.0			40.0			45.0			50.0		
	KW	KW	COP	KW	KW	COP	KW	KW	COP	KW	KW	COP	KW	KW	COP	KW	KW	COP
5.0	101.7	25.8	3.5	97.8	28.6	3.1	93.7	31.6	2.7	89.5	34.9	2.4	85.0	38.5	2.1	44.3	18.9	2.0
6.0	104.7	26.0	3.6	100.7	28.8	3.2	96.5	31.8	2.8	92.2	35.1	2.4	87.6	38.8	2.1	45.8	19.0	2.1
7.0	107.7	26.2	3.7	103.6	29.0	3.2	99.3	32.0	2.8	94.9	35.4	2.5	90.2	39.1	2.1	47.2	19.0	2.1
8.0	110.8	26.4	3.8	106.6	29.2	3.3	102.2	32.3	2.9	97.7	35.6	2.5	92.9	39.3	2.2	48.7	19.1	2.2
9.0	114.0	26.6	3.9	109.7	29.4	3.4	105.2	32.5	3.0	100.5	35.9	2.6	95.6	39.6	2.2	50.2	19.2	2.3
10.0	117.2	26.8	3.9	112.8	29.6	3.5	108.2	32.7	3.0	103.3	36.1	2.6	98.3	39.8	2.3	51.8	19.3	2.3
11.0	120.4	27.0	4.0	115.9	29.8	3.5	111.2	32.9	3.1	106.3	36.4	2.7	56.2	17.5	2.7	53.3	19.4	2.4

NOTES:

1. kW = Compressor Input Power
2. EER = Chiller EER (includes power from compressors, fans, and the control panels 0.8 kW)
3. LCWT = Leaving Chilled Water Temperature
4. Ratings are based upon 2.4 GPM cooler water per ton and 0.0001 fouling factor
5. Rated in accordance with ARI Standard 550/590-98
6. The shaded points are certified in accordance with ARI Standard 550/590-98

Ratings - R-22 (60Hz - SI Units) Cont.

MODEL: YCAL0041EC

AIR TEMPERATURE ON - CONDENSER (°C)

LCWT (°C)	25.0			30.0			35.0			40.0			45.0			50.0		
	KW	KW	COP	KW	KW	COP	KW	KW	COP	KW	KW	COP	KW	KW	COP	KW	KW	COP
5.0	126.9	31.1	3.5	122.4	34.3	3.1	117.6	37.9	2.7	112.5	41.9	2.4	107.1	46.4	2.1	101.3	51.5	1.8
6.0	130.6	31.3	3.5	125.9	34.5	3.1	121.0	38.1	2.8	115.8	42.1	2.4	110.3	46.6	2.1	104.4	51.7	1.8
7.0	134.3	31.6	3.6	129.6	34.7	3.2	124.5	38.3	2.8	119.2	42.3	2.5	113.6	46.9	2.2	107.6	51.9	1.9
8.0	138.1	31.8	3.7	133.2	35.0	3.3	128.1	38.6	2.9	122.7	42.6	2.6	116.9	47.1	2.2	110.9	52.1	1.9
9.0	142.0	32.1	3.8	137.0	35.2	3.4	131.7	38.8	3.0	126.1	42.8	2.6	120.3	47.3	2.3	114.1	52.4	2.0
10.0	145.9	32.3	3.9	140.8	35.5	3.4	135.4	39.1	3.0	129.7	43.1	2.7	123.8	47.6	2.3	117.5	52.6	2.0
11.0	149.9	32.6	3.9	144.6	35.8	3.5	139.1	39.3	3.1	133.3	43.4	2.7	127.3	47.8	2.4	120.9	52.8	2.1

MODEL: YCAL0045EC

AIR TEMPERATURE ON - CONDENSER (°C)

LCWT (°C)	25.0			30.0			35.0			40.0			45.0			50.0		
	KW	KW	COP	KW	KW	COP	KW	KW	COP	KW	KW	COP	KW	KW	COP	KW	KW	COP
5.0	138.1	34.2	3.5	132.3	37.5	3.1	126.4	41.3	2.7	120.4	45.6	2.4	114.1	50.4	2.0	107.3	55.8	1.8
6.0	142.1	34.5	3.6	136.2	37.8	3.1	130.2	41.6	2.8	124.1	45.8	2.4	117.7	50.6	2.1	110.7	56.0	1.8
7.0	146.1	34.7	3.6	140.1	38.1	3.2	134.1	41.9	2.8	127.9	46.1	2.5	121.4	50.9	2.2	114.3	56.3	1.9
8.0	150.2	35.0	3.7	144.1	38.4	3.3	138.0	42.2	2.9	131.7	46.4	2.5	125.0	51.2	2.2	117.9	56.6	1.9
9.0	154.3	35.3	3.8	148.2	38.7	3.4	142.0	42.5	3.0	135.5	46.7	2.6	128.7	51.5	2.3	121.5	56.9	1.9
10.0	158.5	35.7	3.8	152.3	39.0	3.4	146.0	42.8	3.0	139.4	47.1	2.7	132.5	51.9	2.3	125.2	57.2	2.0
11.0	162.7	36.0	3.9	156.4	39.3	3.5	150.0	43.1	3.1	143.3	47.4	2.7	136.4	52.2	2.4	128.9	57.5	2.0

MODEL: YCAL0051EC

AIR TEMPERATURE ON - CONDENSER (°C)

LCWT (°C)	25.0			30.0			35.0			40.0			45.0			50.0		
	KW	KW	COP	KW	KW	COP	KW	KW	COP	KW	KW	COP	KW	KW	COP	KW	KW	COP
5.0	159.2	39.9	3.5	152.4	43.8	3.1	145.7	48.3	2.7	138.8	53.2	2.4	131.6	58.8	2.0	123.9	64.8	1.8
6.0	163.9	40.1	3.6	157.0	44.1	3.2	150.2	48.5	2.8	143.2	53.5	2.4	135.8	59.1	2.1	127.9	65.2	1.8
7.0	168.6	40.4	3.7	161.7	44.3	3.2	154.7	48.8	2.8	147.5	53.8	2.5	140.0	59.4	2.2	132.0	65.5	1.9
8.0	173.5	40.7	3.8	166.4	44.6	3.3	159.3	49.1	2.9	152.0	54.1	2.5	144.4	59.7	2.2	136.2	65.8	1.9
9.0	178.3	41.0	3.8	171.2	44.9	3.4	164.0	49.4	3.0	156.5	54.4	2.6	148.7	60.0	2.3	140.4	66.2	2.0
10.0	183.3	41.3	3.9	176.0	45.2	3.5	168.7	49.7	3.1	161.1	54.7	2.7	153.2	60.3	2.3	144.7	66.5	2.0
11.0	188.3	41.6	4.0	180.9	45.5	3.5	173.4	50.0	3.1	165.7	55.0	2.7	157.7	60.7	2.4	149.0	66.9	2.1

NOTES:

1. kW = Compressor Input Power
2. EER = Chiller EER (includes power from compressors, fans, and the control panels 0.8 kW)
3. LCWT = Leaving Chilled Water Temperature
4. Ratings are based upon 2.4 GPM cooler water per ton and 0.0001 fouling factor
5. Rated in accordance with ARI Standard 550/590-98
6. The shaded points are certified in accordance with ARI Standard 550/590-98

MODEL: YCAL0055EC**AIR TEMPERATURE ON - CONDENSER (°C)**

LCWT (°C)	25.0			30.0			35.0			40.0			45.0			50.0		
	KW	KW	COP	KW	KW	COP	KW	KW	COP	KW	KW	COP	KW	KW	COP	KW	KW	COP
5.0	172.2	43.1	3.5	166.0	47.5	3.1	159.3	52.3	2.7	152.2	57.7	2.4	144.6	63.6	2.1	102.4	49.2	1.8
6.0	177.4	43.4	3.5	170.9	47.7	3.1	164.1	52.6	2.8	156.8	58.0	2.4	149.0	63.9	2.1	105.7	49.4	1.9
7.0	182.6	43.6	3.6	176.0	48.0	3.2	169.0	52.9	2.8	161.6	58.3	2.5	153.6	64.3	2.2	109.0	49.6	1.9
8.0	187.9	43.9	3.7	181.1	48.3	3.3	173.9	53.2	2.9	166.3	58.6	2.6	158.2	64.6	2.2	112.4	49.8	2.0
9.0	193.3	44.2	3.8	186.4	48.5	3.4	179.0	53.4	3.0	171.1	58.9	2.6	162.9	64.9	2.3	115.9	50.1	2.0
10.0	198.8	44.5	3.9	191.7	48.8	3.5	184.1	53.7	3.1	176.1	59.2	2.7	167.7	65.3	2.3	119.4	50.3	2.1
11.0	204.4	44.8	4.0	197.1	49.1	3.5	189.4	54.0	3.1	181.1	59.6	2.7	172.5	65.6	2.4	122.9	50.5	2.2

MODEL: YCAL0061EC**AIR TEMPERATURE ON - CONDENSER (°C)**

LCWT (°C)	25.0			30.0			35.0			40.0			45.0			50.0		
	KW	KW	COP	KW	KW	COP	KW	KW	COP	KW	KW	COP	KW	KW	COP	KW	KW	COP
5.0	201.3	51.1	3.5	193.8	56.4	3.1	186.0	62.2	2.7	177.8	68.7	2.4	169.3	75.8	2.1	160.3	83.6	1.8
6.0	207.2	51.5	3.6	199.6	56.8	3.1	191.6	62.6	2.8	183.2	69.2	2.4	174.4	76.3	2.1	165.2	84.1	1.8
7.0	213.3	51.9	3.6	205.4	57.2	3.2	197.3	63.1	2.8	188.7	69.6	2.5	179.7	76.8	2.2	170.2	84.7	1.9
8.0	219.5	52.3	3.7	211.4	57.6	3.3	203.0	63.5	2.9	194.2	70.1	2.5	185.1	77.3	2.2	175.4	85.2	1.9
9.0	225.7	52.7	3.8	217.5	58.0	3.4	208.9	63.9	3.0	199.9	70.5	2.6	190.5	77.8	2.3	143.0	63.5	2.0
10.0	232.1	53.1	3.9	223.7	58.4	3.4	214.9	64.4	3.0	205.7	71.0	2.7	196.0	78.3	2.3	147.3	63.9	2.1
11.0	238.6	53.5	4.0	230.0	58.9	3.5	221.0	64.8	3.1	211.6	71.5	2.7	201.7	78.8	2.4	151.7	64.2	2.1

MODEL: YCAL0065EC**AIR TEMPERATURE ON - CONDENSER (°C)**

LCWT (°C)	25.0			30.0			35.0			40.0			45.0			50.0		
	KW	KW	COP	KW	KW	COP	KW	KW	COP	KW	KW	COP	KW	KW	COP	KW	KW	COP
5.0	221.3	56.6	3.5	213.0	62.3	3.1	204.4	68.7	2.7	195.3	75.7	2.4	185.7	83.6	2.1	175.5	92.3	1.8
6.0	227.7	57.1	3.6	219.3	62.8	3.2	210.5	69.2	2.8	201.2	76.3	2.4	191.3	84.2	2.1	180.9	92.9	1.8
7.0	234.3	57.6	3.6	225.7	63.3	3.2	216.7	69.7	2.8	207.2	76.9	2.5	197.1	84.8	2.2	186.5	93.6	1.9
8.0	241.1	58.1	3.7	232.2	63.8	3.3	223.0	70.3	2.9	213.3	77.4	2.5	203.0	85.4	2.2	192.1	94.2	1.9
9.0	247.9	58.6	3.8	238.9	64.3	3.4	229.4	70.8	3.0	219.5	78.0	2.6	209.0	86.0	2.3	197.9	94.9	2.0
10.0	254.9	59.1	3.9	245.7	64.9	3.4	236.0	71.4	3.0	225.8	78.6	2.7	215.1	86.7	2.3	162.8	73.4	2.0
11.0	262.1	59.6	4.0	252.6	65.4	3.5	242.7	71.9	3.1	232.3	79.2	2.7	221.3	87.3	2.4	167.7	74.0	2.1

NOTES:

1. kW = Compressor Input Power
2. EER = Chiller EER (includes power from compressors, fans, and the control panels 0.8 kW)
3. LCWT = Leaving Chilled Water Temperature
4. Ratings are based upon 2.4 GPM cooler water per ton and 0.0001 fouling factor
5. Rated in accordance with ARI Standard 550/590-98
6. The shaded points are certified in accordance with ARI Standard 550/590-98

Ratings - R-22 (50Hz - English Units)

MODEL: YCAL0012EC **IPLV=14.6**

AIR TEMPERATURE ON - CONDENSER (°F)

LCWT (°F)	75.0			80.0			85.0			90.0			95.0			100.0		
	TONS	KW	EER	TONS	KW	EER	TONS	KW	EER	TONS	KW	EER	TONS	KW	EER	TONS	KW	EER
40.0	8.5	6.8	13.1	8.3	7.2	12.1	8.1	7.7	11.2	7.9	8.2	10.4	7.7	8.7	9.6	7.5	9.3	8.8
42.0	8.8	6.8	13.5	8.6	7.3	12.5	8.4	7.7	11.6	8.2	8.2	10.7	8.0	8.8	9.9	7.8	9.3	9.1
44.0	9.1	6.9	13.8	8.9	7.3	12.8	8.7	7.8	11.9	8.5	8.3	11.0	8.3	8.8	10.2	8.1	9.4	9.3
45.0	9.3	6.9	14.0	9.1	7.4	13.0	8.9	7.8	12.1	8.7	8.3	11.2	8.5	8.8	10.3	8.2	9.4	9.5
46.0	9.4	6.9	14.2	9.2	7.4	13.2	9.0	7.8	12.2	8.8	8.3	11.3	8.6	8.9	10.4	8.4	9.4	9.6
48.0	9.7	7.0	14.6	9.5	7.4	13.5	9.3	7.9	12.6	9.1	8.4	11.6	8.9	8.9	10.7	8.7	9.5	9.9
50.0	10.0	7.1	15.0	9.8	7.5	13.9	9.6	8.0	12.9	9.4	8.5	11.9	9.2	9.0	11.0	9.0	9.6	10.2

MODEL: YCAL0018EC **IPLV=14.7**

AIR TEMPERATURE ON - CONDENSER (°F)

LCWT (°F)	75.0			80.0			85.0			90.0			95.0			100.0		
	TONS	KW	EER	TONS	KW	EER	TONS	KW	EER	TONS	KW	EER	TONS	KW	EER	TONS	KW	EER
40.0	12.8	10.4	13.4	12.5	11.0	12.5	12.2	11.7	11.6	12.0	12.4	10.7	11.7	13.1	9.9	11.4	13.9	9.1
42.0	13.2	10.5	13.8	12.9	11.1	12.8	12.7	11.8	11.9	12.4	12.5	11.0	12.1	13.2	10.2	11.7	14.0	9.4
44.0	13.7	10.7	14.1	13.4	11.3	13.1	13.1	11.9	12.2	12.8	12.6	11.3	12.5	13.3	10.4	12.1	14.1	9.6
45.0	13.9	10.7	14.2	13.6	11.3	13.2	13.3	12.0	12.3	13.0	12.7	11.4	12.7	13.4	10.6	12.3	14.2	9.8
46.0	14.1	10.8	14.4	13.8	11.4	13.4	13.5	12.0	12.5	13.2	12.7	11.6	12.9	13.5	10.7	12.5	14.2	9.9
48.0	14.6	10.9	14.7	14.3	11.5	13.7	14.0	12.1	12.7	13.6	12.8	11.8	13.3	13.6	11.0	13.0	14.4	10.1
50.0	15.0	11.0	15.0	14.7	11.6	14.0	14.4	12.3	13.0	14.1	13.0	12.1	13.7	13.7	11.2	13.4	14.5	10.4

MODEL: YCAL0021EC **IPLV=15.1**

AIR TEMPERATURE ON - CONDENSER (°F)

LCWT (°F)	75.0			80.0			85.0			90.0			95.0			100.0		
	TONS	KW	EER	TONS	KW	EER	TONS	KW	EER	TONS	KW	EER	TONS	KW	EER	TONS	KW	EER
40.0	15.4	12.4	13.9	15.1	13.2	12.8	14.8	14.0	11.8	14.4	14.9	10.9	14.1	15.9	10.0	13.7	16.9	9.2
42.0	15.9	12.5	14.2	15.6	13.3	13.1	15.3	14.1	12.1	14.9	15.0	11.2	14.5	16.0	10.3	14.2	17.0	9.4
44.0	16.5	12.6	14.5	16.1	13.4	13.4	15.8	14.3	12.4	15.4	15.2	11.4	15.0	16.1	10.5	14.6	17.2	9.6
45.0	16.7	12.7	14.6	16.4	13.5	13.5	16.0	14.3	12.5	15.6	15.3	11.5	15.3	16.2	10.6	14.9	17.3	9.8
46.0	17.0	12.8	14.8	16.6	13.6	13.7	16.3	14.4	12.7	15.9	15.3	11.7	15.5	16.3	10.8	15.1	17.3	9.9
48.0	17.5	12.9	15.1	17.1	13.7	14.0	16.8	14.6	12.9	16.4	15.5	11.9	16.0	16.4	11.0	15.6	17.5	10.1
50.0	18.0	13.1	15.4	17.7	13.9	14.3	17.3	14.7	13.2	16.9	15.6	12.2	16.5	16.6	11.2	16.1	17.6	10.3

NOTES:

1. kW = Compressor Input Power
2. EER = Chiller EER (includes power from compressors, fans, and the control panels 0.8 kW)
3. LCWT = Leaving Chilled Water Temperature
4. Ratings are based upon 2.4 GPM cooler water per ton and 0.0001 fouling factor
5. Rated in accordance with ARI Standard 550/590-98
6. The shaded points are certified in accordance with ARI Standard 550/590-98

MODEL: YCAL0012EC **IPLV=14.6****AIR TEMPERATURE ON - CONDENSER (°F)**

LCWT (°F)	105			110.0			115.0			120.0			125.0		
	TONS	KW	EER	TONS	KW	EER	TONS	KW	EER	TONS	KW	EER	TONS	KW	EER
40.0	7.3	9.9	8.1	7.1	10.6	7.4	6.9	11.3	6.7	6.6	12.1	6.1	6.4	12.9	5.5
42.0	7.6	10.0	8.3	7.4	10.6	7.6	7.1	11.3	6.9	6.9	12.1	6.3	6.6	13.0	5.7
44.0	7.9	10.0	8.6	7.6	10.7	7.9	7.4	11.4	7.2	7.2	12.2	6.5	6.9	13.0	5.9
45.0	8	10.0	8.7	7.8	10.7	8.0	7.5	11.4	7.3	7.3	12.2	6.6	7.0	13.0	6.0
46.0	8.1	10.1	8.8	7.9	10.7	8.1	7.7	11.4	7.4	7.4	12.2	6.7	7.1	13.1	6.1
48.0	8.4	10.1	9.1	8.2	10.8	8.3	7.9	11.5	7.6	7.7	12.3	6.9	7.4	13.1	6.3
50.0	8.7	10.2	9.4	8.5	10.8	8.6	8.2	11.6	7.9	8.0	12.3	7.2	7.7	13.2	6.5

MODEL: YCAL0018EC **IPLV=14.7****AIR TEMPERATURE ON - CONDENSER (°F)**

LCWT (°F)	105			110.0			115.0			120.0			125.0		
	TONS	KW	EER	TONS	KW	EER	TONS	KW	EER	TONS	KW	EER	TONS	KW	EER
40.0	11	14.8	8.4	10.7	15.7	7.7	10.3	16.8	7.0	10.0	17.9	6.3	9.6	19.1	5.7
42.0	11.4	14.9	8.6	11.1	15.8	7.9	10.7	16.9	7.2	10.3	18.0	6.5	10.0	19.2	5.9
44.0	11.8	15.0	8.9	11.5	15.9	8.1	11.1	17.0	7.4	10.7	18.1	6.7	10.3	19.3	6.1
45.0	12	15.1	9.0	11.6	16.0	8.2	11.3	17.0	7.5	10.9	18.2	6.8	10.5	19.4	6.2
46.0	12.2	15.1	9.1	11.8	16.1	8.3	11.5	17.1	7.6	11.1	18.2	6.9	10.7	19.4	6.3
48.0	12.6	15.2	9.3	12.2	16.2	8.6	11.9	17.2	7.8	11.5	18.3	7.1	11.0	19.5	6.5
50.0	13	15.4	9.6	12.6	16.3	8.8	12.3	17.3	8.0	11.8	18.4	7.3	11.4	19.7	6.6

MODEL: YCAL0021EC **IPLV=15.1****AIR TEMPERATURE ON - CONDENSER (°F)**

LCWT (°F)	105			110.0			115.0			120.0			125.0		
	TONS	KW	EER	TONS	KW	EER	TONS	KW	EER	TONS	KW	EER	TONS	KW	EER
40.0	13.3	18.0	8.4	12.9	19.2	7.7	12.5	20.5	7.0	12.0	21.8	6.3	11.5	23.3	5.7
42.0	13.8	18.2	8.6	13.3	19.4	7.9	12.9	20.6	7.2	12.4	22.0	6.5	11.9	23.5	5.9
44.0	14.2	18.3	8.8	13.8	19.5	8.1	13.3	20.8	7.3	12.9	22.2	6.7	12.3	23.6	6.0
45.0	14.5	18.4	8.9	14.0	19.6	8.2	13.6	20.9	7.4	13.1	22.2	6.8	12.6	23.7	6.1
46.0	14.7	18.5	9.1	14.2	19.7	8.3	13.8	20.9	7.5	13.3	22.3	6.8	12.8	23.8	6.2
48.0	15.2	18.6	9.3	14.7	19.8	8.5	14.2	21.1	7.7	13.7	22.5	7.0	13.2	23.9	6.4
50.0	15.6	18.8	9.5	15.2	20.0	8.7	14.7	21.3	7.9	14.2	22.6	7.2	7.7	10.3	8.2

NOTES:

1. kW = Compressor Input Power
2. EER = Chiller EER (includes power from compressors, fans, and the control panels 0.8 kW)
3. LCWT = Leaving Chilled Water Temperature
4. Ratings are based upon 2.4 GPM cooler water per ton and 0.0001 fouling factor
5. Rated in accordance with ARI Standard 550/590-98
6. The shaded points are certified in accordance with ARI Standard 550/590-98

Ratings - R-22 (50Hz - English Units) -Cont.

MODEL: YCAL0025EC **IPLV=13.5**

AIR TEMPERATURE ON - CONDENSER (°F)

LCWT (°F)	75.0			80.0			85.0			90.0			95.0			100.0		
	TONS	KW	EER	TONS	KW	EER	TONS	KW	EER	TONS	KW	EER	TONS	KW	EER	TONS	KW	EER
40.0	18.9	15.4	12.3	18.5	16.2	11.6	18.2	17.1	10.8	17.8	18.1	10.1	17.4	19.1	9.4	16.9	20.2	8.8
42.0	19.5	15.5	12.7	19.2	16.3	11.9	18.8	17.2	11.2	18.4	18.1	10.4	18.0	19.2	9.7	17.5	20.3	9.0
44.0	20.2	15.6	13.0	19.8	16.4	12.3	19.4	17.3	11.5	19.0	18.2	10.8	18.6	19.2	10.0	18.1	20.3	9.3
45.0	20.6	15.6	13.2	20.2	16.4	12.4	19.8	17.3	11.7	19.3	18.3	10.9	18.9	19.3	10.2	18.4	20.4	9.5
46.0	20.9	15.7	13.4	20.5	16.5	12.6	20.1	17.4	11.8	19.7	18.3	11.1	19.2	19.3	10.3	18.7	20.4	9.6
48.0	21.6	15.8	13.8	21.2	16.6	13.0	20.8	17.5	12.2	20.3	18.4	11.4	19.9	19.4	10.6	19.4	20.5	9.9
50.0	22.3	15.9	14.2	21.9	16.7	13.3	21.4	17.5	12.5	21.0	18.5	11.7	20.5	19.5	10.9	20.0	20.6	10.2

MODEL: YCAL0027EC **IPLV=13.9**

AIR TEMPERATURE ON - CONDENSER (°F)

LCWT (°F)	75.0			80.0			85.0			90.0			95.0			100.0		
	TONS	KW	EER	TONS	KW	EER	TONS	KW	EER	TONS	KW	EER	TONS	KW	EER	TONS	KW	EER
40.0	20.8	16.9	12.6	20.4	17.8	11.8	20.0	18.9	11.0	19.6	20.0	10.2	19.1	21.2	9.5	18.7	22.4	8.8
42.0	21.5	17.0	13.0	21.1	17.9	12.1	20.7	19.0	11.3	20.2	20.1	10.5	19.8	21.3	9.8	19.3	22.5	9.1
44.0	22.3	17.1	13.3	21.8	18.0	12.5	21.4	19.1	11.6	20.9	20.2	10.8	20.5	21.4	10.1	20.0	22.6	9.4
45.0	22.6	17.1	13.5	22.2	18.1	12.6	21.7	19.1	11.8	21.3	20.2	11.0	20.8	21.4	10.2	20.3	22.7	9.5
46.0	23.0	17.2	13.7	22.6	18.1	12.8	22.1	19.2	12.0	21.6	20.3	11.2	21.1	21.5	10.4	20.6	22.7	9.6
48.0	23.8	17.3	14.0	23.3	18.2	13.2	22.8	19.3	12.3	22.3	20.4	11.5	21.8	21.6	10.7	21.3	22.8	9.9
50.0	24.5	17.4	14.4	24.1	18.4	13.5	23.6	19.4	12.6	23.1	20.5	11.8	22.6	21.7	11.0	22.0	22.9	10.2

MODEL: YCAL0032EC **IPLV=14.2**

AIR TEMPERATURE ON - CONDENSER (°F)

LCWT (°F)	75.0			80.0			85.0			90.0			95.0			100.0		
	TONS	KW	EER	TONS	KW	EER	TONS	KW	EER	TONS	KW	EER	TONS	KW	EER	TONS	KW	EER
40.0	24.3	20.0	12.7	23.8	21.2	11.8	23.3	22.4	11.0	22.8	23.8	10.2	22.3	25.2	9.5	21.7	26.8	8.8
42.0	25.1	20.1	13.0	24.6	21.3	12.1	24.1	22.6	11.3	23.6	23.9	10.5	23.0	25.4	9.7	22.5	26.9	9.0
44.0	25.9	20.3	13.4	25.4	21.5	12.5	24.9	22.7	11.6	24.4	24.1	10.8	23.8	25.6	10.0	23.2	27.1	9.3
45.0	26.4	20.3	13.6	25.8	21.5	12.6	25.3	22.8	11.8	24.8	24.2	10.9	24.2	25.6	10.1	23.6	27.2	9.4
46.0	26.8	20.4	13.7	26.2	21.6	12.8	25.7	22.9	11.9	25.2	24.3	11.1	24.6	25.7	10.3	24.0	27.3	9.5
48.0	27.7	20.6	14.1	27.1	21.8	13.1	26.5	23.1	12.2	26.0	24.4	11.4	25.4	25.9	10.6	24.8	27.4	9.8
50.0	28.5	20.7	14.4	28.0	22.0	13.4	27.4	23.2	12.5	26.8	24.6	11.6	26.2	26.1	10.8	25.6	27.6	10.0

NOTES:

1. kW = Compressor Input Power
2. EER = Chiller EER (includes power from compressors, fans, and the control panels 0.8 kW)
3. LCWT = Leaving Chilled Water Temperature
4. Ratings are based upon 2.4 GPM cooler water per ton and 0.0001 fouling factor
5. Rated in accordance with ARI Standard 550/590-98
6. The shaded points are certified in accordance with ARI Standard 550/590-98

MODEL: YCAL0025EC**IPLV=13.5****AIR TEMPERATURE ON - CONDENSER (°F)**

LCWT (°F)	105			110.0			115.0			120.0			125.0		
	TONS	KW	EER	TONS	KW	EER	TONS	KW	EER	TONS	KW	EER	TONS	KW	EER
40.0	16.5	21.3	8.1	16.0	22.6	7.5	15.5	23.9	6.9	15.0	25.3	6.4	14.4	26.8	5.8
42.0	17.1	21.4	8.4	16.6	22.7	7.7	16.1	24.0	7.1	15.5	25.4	6.6	15.0	26.9	6.0
44.0	17.7	21.5	8.6	17.2	22.8	8.0	16.6	24.1	7.4	16.1	25.5	6.8	15.6	27.0	6.2
45.0	18	21.5	8.8	17.5	22.8	8.1	16.9	24.1	7.5	16.4	25.5	6.9	15.8	27.0	6.3
46.0	18.3	21.6	8.9	17.8	22.8	8.2	17.2	24.2	7.6	16.7	25.6	7.0	16.1	27.1	6.4
48.0	18.9	21.7	9.2	18.4	22.9	8.5	17.8	24.3	7.8	17.3	25.7	7.2	16.7	27.2	6.6
50.0	19.5	21.8	9.5	19.0	23.0	8.8	18.4	24.3	8.1	17.9	25.8	7.5	17.3	27.3	6.9

MODEL: YCAL0027EC**IPLV=13.9****AIR TEMPERATURE ON - CONDENSER (°F)**

LCWT (°F)	105			110.0			115.0			120.0			125.0		
	TONS	KW	EER	TONS	KW	EER	TONS	KW	EER	TONS	KW	EER	TONS	KW	EER
40.0	18.2	23.7	8.2	17.7	25.1	7.5	17.2	26.6	7.0	16.6	28.2	6.4	16.0	29.9	5.9
42.0	18.8	23.8	8.4	18.3	25.3	7.8	17.8	26.8	7.2	17.2	28.3	6.6	16.6	30.0	6.0
44.0	19.5	24.0	8.7	18.9	25.4	8.0	18.4	26.9	7.4	17.8	28.5	6.8	17.2	30.1	6.2
45.0	19.8	24.0	8.8	19.3	25.4	8.1	18.7	26.9	7.5	18.1	28.5	6.9	17.5	30.2	6.3
46.0	20.1	24.1	8.9	19.6	25.5	8.3	19.0	27.0	7.6	18.4	28.6	7.0	17.8	30.3	6.4
48.0	20.8	24.2	9.2	20.3	25.6	8.5	19.7	27.1	7.8	19.1	28.7	7.2	18.5	30.4	6.6
50.0	21.5	24.3	9.4	20.9	25.7	8.7	20.3	27.2	8.1	19.7	28.8	7.4	19.1	30.5	6.8

MODEL: YCAL0032EC**IPLV=14.2****AIR TEMPERATURE ON - CONDENSER (°F)**

LCWT (°F)	105			110.0			115.0			120.0			125.0		
	TONS	KW	EER	TONS	KW	EER	TONS	KW	EER	TONS	KW	EER	TONS	KW	EER
40.0	21.2	28.4	8.1	20.6	30.1	7.5	20.0	31.9	6.9	19.4	33.7	6.3	18.7	35.7	5.8
42.0	21.9	28.5	8.3	21.3	30.2	7.7	20.7	32.0	7.1	20.0	33.9	6.5	19.4	35.9	6.0
44.0	22.7	28.7	8.6	22.0	30.4	7.9	21.4	32.2	7.3	20.7	34.1	6.7	20.0	36.2	6.1
45.0	23	28.8	8.7	22.4	30.5	8.0	21.8	32.3	7.4	21.1	34.3	6.8	20.4	36.3	6.2
46.0	23.4	28.9	8.8	22.8	30.6	8.1	22.1	32.4	7.5	21.4	34.4	6.9	20.7	36.4	6.3
48.0	24.2	29.1	9.0	23.5	30.8	8.3	22.8	32.6	7.7	22.1	34.6	7.1	21.4	36.6	6.5
50.0	24.9	29.3	9.3	24.3	31.0	8.6	23.6	32.8	7.9	22.8	34.8	7.3	22.1	36.8	6.7

NOTES:

1. kW = Compressor Input Power
2. EER = Chiller EER (includes power from compressors, fans, and the control panels 0.8 kW)
3. LCWT = Leaving Chilled Water Temperature
4. Ratings are based upon 2.4 GPM cooler water per ton and 0.0001 fouling factor
5. Rated in accordance with ARI Standard 550/590-98
6. The shaded points are certified in accordance with ARI Standard 550/590-98

Ratings - R-22 (50Hz - English Units) - Cont.

MODEL: YCAL0041EC **IPLV=16.2**

AIR TEMPERATURE ON - CONDENSER (°F)

LCWT (°F)	75.0			80.0			85.0			90.0			95.0			100.0		
	TONS	KW	EER	TONS	KW	EER	TONS	KW	EER	TONS	KW	EER	TONS	KW	EER	TONS	KW	EER
40.0	30.4	23.6	13.6	29.8	25.1	12.6	29.1	26.7	11.7	28.5	28.4	10.8	27.9	30.2	10.0	27.2	32.2	9.2
42.0	31.4	23.8	13.9	30.8	25.3	12.9	30.1	26.9	12.0	29.5	28.6	11.1	28.8	30.4	10.3	28.1	32.3	9.5
44.0	32.4	24.0	14.3	31.8	25.5	13.3	31.1	27.1	12.3	30.4	28.8	11.4	29.8	30.6	10.6	29.1	32.5	9.7
45.0	33.0	24.1	14.4	32.3	25.6	13.4	31.6	27.2	12.5	30.9	28.9	11.6	30.2	30.7	10.7	29.5	32.6	9.9
46.0	33.5	24.2	14.6	32.8	25.7	13.6	32.1	27.3	12.6	31.4	29.0	11.7	30.7	30.8	10.8	30.0	32.7	10.0
48.0	34.5	24.5	15.0	33.8	25.9	13.9	33.1	27.5	12.9	32.5	29.2	12.0	31.7	31.0	11.1	31.0	33.0	10.3
50.0	35.6	24.7	15.3	34.9	26.2	14.2	34.2	27.7	13.2	33.5	29.4	12.3	32.8	31.2	11.4	32.0	33.2	10.5

MODEL: YCAL0045EC **IPLV=16.1**

AIR TEMPERATURE ON - CONDENSER (°F)

LCWT (°F)	75.0			80.0			85.0			90.0			95.0			100.0		
	TONS	KW	EER	TONS	KW	EER	TONS	KW	EER	TONS	KW	EER	TONS	KW	EER	TONS	KW	EER
40.0	32.9	25.9	13.6	32.2	27.5	12.6	31.5	29.2	11.7	30.8	31.0	10.8	30.0	32.9	10.0	29.2	35.0	9.2
42.0	34.0	26.2	13.9	33.3	27.8	12.9	32.6	29.4	12.0	31.8	31.2	11.1	31.1	33.2	10.2	30.2	35.3	9.4
44.0	35.1	26.4	14.2	34.4	28.0	13.2	33.7	29.7	12.3	32.9	31.5	11.4	32.1	33.4	10.5	31.3	35.5	9.7
45.0	35.7	26.5	14.4	34.9	28.1	13.4	34.2	29.8	12.4	33.4	31.6	11.5	32.6	33.5	10.6	31.8	35.6	9.8
46.0	36.2	26.7	14.5	35.5	28.2	13.5	34.7	29.9	12.6	34.0	31.7	11.7	33.2	33.7	10.8	32.3	35.7	10.0
48.0	37.4	26.9	14.9	36.6	28.5	13.8	35.9	30.2	12.9	35.1	32.0	11.9	34.2	33.9	11.1	33.4	36.0	10.2
50.0	38.5	27.2	15.2	37.8	28.8	14.2	37.0	30.5	13.2	36.2	32.3	12.2	35.3	34.2	11.3	34.4	36.3	10.5

MODEL: YCAL0051EC **IPLV= 15.7**

AIR TEMPERATURE ON - CONDENSER (°F)

LCWT (°F)	75.0			80.0			85.0			90.0			95.0			100.0		
	TONS	KW	EER	TONS	KW	EER	TONS	KW	EER	TONS	KW	EER	TONS	KW	EER	TONS	KW	EER
40.0	37.9	30.8	13.3	37.1	32.6	12.4	36.3	34.6	11.5	35.5	36.7	10.7	34.6	38.9	9.9	33.8	41.3	9.1
42.0	39.1	31.0	13.7	38.3	32.9	12.7	37.5	34.8	11.8	36.7	36.9	11.0	35.8	39.1	10.1	34.9	41.5	9.4
44.0	40.4	31.3	14.0	39.6	33.1	13.1	38.8	35.1	12.2	37.9	37.1	11.3	37.0	39.4	10.4	36.1	41.7	9.6
45.0	41.0	31.4	14.2	40.2	33.2	13.2	39.4	35.2	12.3	38.5	37.3	11.4	37.6	39.5	10.6	36.7	41.9	9.8
46.0	41.7	31.5	14.4	40.9	33.4	13.4	40.0	35.3	12.5	39.2	37.4	11.6	38.3	39.6	10.7	37.3	42.0	9.9
48.0	43.0	31.8	14.7	42.2	33.6	13.7	41.3	35.6	12.8	40.4	37.6	11.9	39.5	39.9	11.0	38.5	42.2	10.2
50.0	44.4	32.1	15.1	43.5	33.9	14.1	42.6	35.8	13.1	41.7	37.9	12.2	40.8	40.1	11.3	39.8	42.5	10.4

NOTES:

1. kW = Compressor Input Power
2. EER = Chiller EER (includes power from compressors, fans, and the control panels 0.8 kW)
3. LCWT = Leaving Chilled Water Temperature
4. Ratings are based upon 2.4 GPM cooler water per ton and 0.0001 fouling factor
5. Rated in accordance with ARI Standard 550/590-98
6. The shaded points are certified in accordance with ARI Standard 550/590-98

MODEL: YCAL0041EC **IPLV= 16.2****AIR TEMPERATURE ON - CONDENSER (°F)**

LCWT (°F)	105			110.0			115.0			120.0			125.0		
	TONS	KW	EER	TONS	KW	EER	TONS	KW	EER	TONS	KW	EER	TONS	KW	EER
26.5	40.0	34.3	8.5	25.7	36.5	7.8	25.0	39.0	7.1	24.1	41.6	6.5	23.2	44.4	5.8
27.4	42.0	34.5	8.7	26.6	36.7	8.0	25.8	39.2	7.3	25.0	41.8	6.7	24.1	44.6	6.0
28.3	44.0	34.7	9.0	27.5	36.9	8.2	26.7	39.4	7.5	25.9	42.0	6.9	24.9	44.8	6.2
28.8	45.0	34.8	9.1	28.0	37.0	8.4	27.2	39.5	7.6	26.3	42.1	7.0	25.4	44.9	6.3
29.3	46.0	34.9	9.2	28.5	37.1	8.5	27.6	39.6	7.8	26.8	42.2	7.1	25.8	45.0	6.4
30.2	48.0	35.1	9.5	29.4	37.3	8.7	28.6	39.8	8.0	27.7	42.4	7.3	26.7	45.2	6.6
31.2	50.0	35.3	9.7	30.4	37.5	8.9	29.5	40.0	8.2	28.6	42.6	7.5	27.6	45.4	6.8

MODEL: YCAL0045EC **IPLV= 16.1****AIR TEMPERATURE ON - CONDENSER (°F)**

LCWT (°F)	105			110.0			115.0			120.0			125.0		
	TONS	KW	EER	TONS	KW	EER	TONS	KW	EER	TONS	KW	EER	TONS	KW	EER
28.4	40.0	37.3	8.4	27.6	39.7	7.7	26.6	42.2	7.0	25.7	45.0	6.4	24.7	47.9	5.8
29.4	42.0	37.5	8.7	28.5	39.9	7.9	27.6	42.5	7.2	26.6	45.2	6.6	25.6	48.2	6.0
30.4	44.0	37.7	8.9	29.5	40.1	8.2	28.6	42.7	7.5	27.6	45.4	6.8	26.5	48.4	6.2
30.9	45.0	37.8	9.0	30.0	40.2	8.3	29.1	42.8	7.6	28.1	45.6	6.9	27.0	48.5	6.3
31.4	46.0	38.0	9.2	30.5	40.4	8.4	29.6	42.9	7.7	28.5	45.7	7.0	27.5	48.6	6.4
32.5	48.0	38.2	9.4	31.5	40.6	8.6	30.6	43.2	7.9	29.5	45.9	7.2	28.4	48.9	6.6
33.5	50.0	38.5	9.6	32.6	40.9	8.9	31.6	43.4	8.1	30.5	46.2	7.4	29.4	49.1	6.7

MODEL: YCAL0051EC **IPLV= 15.7****AIR TEMPERATURE ON - CONDENSER (°F)**

LCWT (°F)	105			110.0			115.0			120.0			125.0		
	TONS	KW	EER	TONS	KW	EER	TONS	KW	EER	TONS	KW	EER	TONS	KW	EER
32.8	40.0	43.8	8.4	31.9	46.4	7.7	30.9	49.3	7.1	29.8	52.3	6.5	28.7	55.4	5.9
34.0	42.0	44.0	8.6	33.0	46.7	7.9	32.0	49.5	7.3	30.9	52.5	6.7	29.8	55.7	6.1
35.1	44.0	44.3	8.9	34.2	46.9	8.2	33.1	49.8	7.5	32.0	52.8	6.9	30.9	56.0	6.3
35.7	45.0	44.4	9.0	34.7	47.0	8.3	33.7	49.9	7.6	32.6	52.9	7.0	31.4	56.1	6.4
36.3	46.0	44.5	9.1	35.3	47.2	8.4	34.2	50.0	7.7	33.1	53.0	7.1	32.0	56.2	6.5
37.5	48.0	44.7	9.4	36.5	47.4	8.6	35.4	50.3	7.9	34.3	53.3	7.3	33.1	56.5	6.6
38.8	50.0	45.0	9.6	37.7	47.7	8.9	36.6	50.5	8.2	35.4	53.6	7.5	34.2	56.8	6.8

NOTES:

1. kW = Compressor Input Power
2. EER = Chiller EER (includes power from compressors, fans, and the control panels 0.8 kW)
3. LCWT = Leaving Chilled Water Temperature
4. Ratings are based upon 2.4 GPM cooler water per ton and 0.0001 fouling factor
5. Rated in accordance with ARI Standard 550/590-98
6. The shaded points are certified in accordance with ARI Standard 550/590-98

Ratings - R-22 (50Hz - English Units) - Cont.

MODEL: YCAL0055EC **IPLV=15.0**

AIR TEMPERATURE ON - CONDENSER (°F)

LCWT (°F)	75.0			80.0			85.0			90.0			95.0			100.0		
	TONS	KW	EER	TONS	KW	EER	TONS	KW	EER	TONS	KW	EER	TONS	KW	EER	TONS	KW	EER
40.0	41.2	33.8	13.1	40.4	35.7	12.2	39.6	37.8	11.4	38.7	40.0	10.6	37.8	42.4	9.8	36.9	44.9	9.1
42.0	42.6	34.0	13.5	41.7	36.0	12.6	40.9	38.0	11.7	40.0	40.3	10.9	39.1	42.6	10.1	38.2	45.1	9.4
44.0	44.0	34.3	13.8	43.1	36.2	12.9	42.3	38.3	12.0	41.4	40.5	11.2	40.4	42.8	10.4	39.5	45.4	9.6
45.0	44.7	34.4	14.0	43.8	36.3	13.1	43.0	38.4	12.2	42.1	40.6	11.3	41.1	43.0	10.5	40.1	45.5	9.8
46.0	45.4	34.5	14.2	44.5	36.4	13.3	43.7	38.5	12.4	42.7	40.7	11.5	41.8	43.1	10.7	40.8	45.6	9.9
48.0	46.9	34.7	14.6	46.0	36.7	13.6	45.1	38.8	12.7	44.1	40.9	11.8	43.1	43.3	11.0	42.1	45.8	10.2
50.0	48.4	35.0	14.9	47.5	36.9	14.0	46.5	39.0	13.0	45.6	41.2	12.1	44.5	43.6	11.3	43.5	46.1	10.4

MODEL: YCAL0061EC **IPLV=15.7**

AIR TEMPERATURE ON - CONDENSER (°F)

LCWT (°F)	75.0			80.0			85.0			90.0			95.0			100.0		
	TONS	KW	EER	TONS	KW	EER	TONS	KW	EER	TONS	KW	EER	TONS	KW	EER	TONS	KW	EER
40.0	48.0	40.0	13.1	47.0	42.3	12.2	46.0	44.8	11.3	45.0	47.5	10.5	44.0	50.3	9.8	43.0	53.3	9.0
42.0	49.6	40.3	13.5	48.6	42.6	12.5	47.6	45.1	11.6	46.6	47.8	10.8	45.5	50.6	10.0	44.4	53.6	9.3
44.0	51.2	40.6	13.8	50.2	42.9	12.9	49.1	45.5	12.0	48.1	48.1	11.1	47.0	51.0	10.3	45.9	54.0	9.5
45.0	52.0	40.7	14.0	51.0	43.1	13.0	49.9	45.6	12.1	48.9	48.3	11.2	47.8	51.1	10.4	46.7	54.2	9.7
46.0	52.9	40.9	14.2	51.8	43.3	13.2	50.8	45.8	12.3	49.7	48.5	11.4	48.6	51.3	10.6	47.4	54.3	9.8
48.0	54.6	41.2	14.5	53.5	43.6	13.5	52.4	46.1	12.6	51.3	48.8	11.7	50.2	51.6	10.8	49.0	54.7	10.0
50.0	56.3	41.6	14.9	55.2	43.9	13.8	54.1	46.5	12.9	52.9	49.1	12.0	51.8	52.0	11.1	50.6	55.1	10.3

MODEL: YCAL0065EC **IPLV=15.8**

AIR TEMPERATURE ON - CONDENSER (°F)

LCWT (°F)	75.0			80.0			85.0			90.0			95.0			100.0		
	TONS	KW	EER	TONS	KW	EER	TONS	KW	EER	TONS	KW	EER	TONS	KW	EER	TONS	KW	EER
40.0	52.5	44.2	13.1	51.4	46.7	12.2	50.3	49.4	11.3	49.2	52.3	10.5	48.1	55.4	9.7	46.9	58.7	9.0
42.0	54.2	44.5	13.4	53.1	47.1	12.5	52.0	49.8	11.6	50.9	52.7	10.8	49.7	55.8	10.0	48.5	59.1	9.2
44.0	55.9	44.9	13.8	54.8	47.5	12.8	53.7	50.2	11.9	52.5	53.1	11.1	51.3	56.2	10.2	50.1	59.6	9.5
45.0	56.8	45.1	13.9	55.7	47.7	13.0	54.6	50.4	12.1	53.4	53.3	11.2	52.2	56.4	10.4	50.9	59.8	9.6
46.0	57.7	45.3	14.1	56.6	47.9	13.1	55.4	50.6	12.2	54.2	53.5	11.3	53.0	56.7	10.5	51.7	60.0	9.7
48.0	59.6	45.7	14.4	58.4	48.3	13.4	57.2	51.0	12.5	56.0	54.0	11.6	54.7	57.1	10.8	53.4	60.4	10.0
50.0	61.4	46.1	14.7	60.2	48.7	13.7	59.0	51.5	12.8	57.7	54.4	11.9	56.5	57.5	11.0	55.1	60.9	10.2

NOTES:

1. kW = Compressor Input Power
2. EER = Chiller EER (includes power from compressors, fans, and the control panels 0.8 kW)
3. LCWT = Leaving Chilled Water Temperature
4. Ratings are based upon 2.4 GPM cooler water per ton and 0.0001 fouling factor
5. Rated in accordance with ARI Standard 550/590-98
6. The shaded points are certified in accordance with ARI Standard 550/590-98

MODEL: YCAL0055EC **IPLV=15.0****AIR TEMPERATURE ON - CONDENSER (°F)**

LCWT (°F)	105			110.0			115.0			120.0			125.0		
	TONS	KW	EER	TONS	KW	EER	TONS	KW	EER	TONS	KW	EER	TONS	KW	EER
36.0	40.0	47.5	8.4	35.0	50.3	7.7	33.9	53.3	7.1	32.8	56.4	6.5	31.7	59.7	6.0
37.2	42.0	47.8	8.6	36.2	50.6	8.0	35.1	53.6	7.3	34.0	56.7	6.7	32.8	60.0	6.2
38.5	44.0	48.0	8.9	37.4	50.9	8.2	36.3	53.8	7.6	35.2	57.0	6.9	34.0	60.3	6.4
39.1	45.0	48.2	9.0	38.1	51.0	8.3	36.9	54.0	7.7	35.8	57.1	7.0	34.6	60.5	6.4
39.8	46.0	48.3	9.1	38.7	51.1	8.4	37.6	54.1	7.8	36.4	57.3	7.1	35.2	60.6	6.5
41.1	48.0	48.5	9.4	40.0	51.4	8.7	38.8	54.4	8.0	37.6	57.6	7.3	36.4	60.9	6.7
42.4	50.0	48.8	9.7	41.3	51.7	8.9	40.1	54.7	8.2	38.9	57.9	7.6	37.6	61.2	6.9

MODEL: YCAL0061EC **IPLV=15.7****AIR TEMPERATURE ON - CONDENSER (°F)**

LCWT (°F)	105			110.0			115.0			120.0			125.0		
	TONS	KW	EER	TONS	KW	EER	TONS	KW	EER	TONS	KW	EER	TONS	KW	EER
41.9	40.0	56.5	8.3	40.7	59.9	7.7	39.5	63.5	7.0	38.2	67.3	6.4	36.8	71.3	5.9
43.3	42.0	56.8	8.6	42.1	60.3	7.9	40.9	63.8	7.2	39.5	67.7	6.6	38.1	71.7	6.1
44.8	44.0	57.2	8.8	43.6	60.6	8.1	42.3	64.3	7.4	40.9	68.1	6.8	39.5	72.2	6.2
45.5	45.0	57.4	8.9	44.3	60.8	8.2	43.0	64.5	7.5	41.6	68.3	6.9	40.2	72.4	6.3
46.3	46.0	57.6	9.0	45.0	61.0	8.3	43.7	64.7	7.6	42.3	68.5	7.0	40.8	72.6	6.4
47.8	48.0	57.9	9.3	46.5	61.4	8.5	45.1	65.1	7.9	43.7	68.9	7.2	42.2	73.0	6.6
49.3	50.0	58.3	9.5	48.0	61.8	8.8	46.6	65.5	8.1	45.2	69.4	7.4	43.7	73.5	6.8

MODEL: YCAL0065EC **IPLV=15.8****AIR TEMPERATURE ON - CONDENSER (°F)**

LCWT (°F)	105			110.0			115.0			120.0			125.0		
	TONS	KW	EER	TONS	KW	EER	TONS	KW	EER	TONS	KW	EER	TONS	KW	EER
45.6	40.0	62.2	8.3	44.3	65.9	7.6	42.8	69.9	7.0	41.3	74.2	6.3	39.6	78.7	5.8
47.2	42.0	62.7	8.5	45.8	66.4	7.8	44.3	70.4	7.2	42.8	74.7	6.5	41.1	79.2	5.9
48.8	44.0	63.1	8.7	47.4	66.9	8.0	45.9	70.9	7.4	44.3	75.2	6.7	42.6	79.8	6.1
49.6	45.0	63.3	8.8	48.2	67.1	8.1	46.7	71.2	7.5	45.1	75.5	6.8	43.4	80.1	6.2
50.4	46.0	63.6	9.0	49.0	67.4	8.2	47.4	71.4	7.6	45.8	75.7	6.9	44.1	80.3	6.3
52.0	48.0	64.0	9.2	50.6	67.9	8.5	49.0	72.0	7.8	47.4	76.3	7.1	35.1	54.3	7.2
53.7	50.0	64.5	9.4	52.2	68.4	8.7	50.6	72.5	8.0	49.0	76.8	7.3	36.3	54.6	7.4

NOTES:

1. kW = Compressor Input Power
2. EER = Chiller EER (includes power from compressors, fans, and the control panels 0.8 kW)
3. LCWT = Leaving Chilled Water Temperature
4. Ratings are based upon 2.4 GPM cooler water per ton and 0.0001 fouling factor
5. Rated in accordance with ARI Standard 550/590-98
6. The shaded points are certified in accordance with ARI Standard 550/590-98

Ratings - R-22 (50Hz - SI Units)

MODEL:YCAL0012EC

AIR TEMPERATURE ON - CONDENSER (°C)

LCWT (°C)	25.0			30.0			35.0			40.0			45.0			50.0		
	KW	KW	COP	KW	KW	COP	KW	KW	COP	KW	KW	COP	KW	KW	COP	KW	KW	COP
5.0	30.2	7.0	3.8	29.0	7.8	3.3	27.7	8.7	2.8	26.4	9.8	2.4	25.0	11.0	2.1	23.4	12.4	1.7
6.0	31.1	7.0	3.9	29.9	7.9	3.4	28.6	8.8	2.9	27.3	9.8	2.5	25.8	11.1	2.1	24.2	12.5	1.8
7.0	32.1	7.1	4.0	30.8	7.9	3.5	29.5	8.8	3.0	28.1	9.9	2.6	26.7	11.1	2.2	25.1	12.5	1.9
8.0	33.0	7.1	4.1	31.8	8.0	3.6	30.4	8.9	3.1	29.0	9.9	2.7	27.5	11.2	2.3	25.9	12.6	1.9
9.0	34.0	7.2	4.2	32.7	8.0	3.6	31.4	8.9	3.2	29.9	10.0	2.7	28.4	11.2	2.3	26.7	12.6	2.0
10.0	35.0	7.2	4.3	33.7	8.1	3.7	32.3	9.0	3.2	30.8	10.0	2.8	29.3	11.3	2.4	27.6	12.7	2.0
11.0	36.1	7.3	4.4	34.7	8.1	3.8	33.3	9.0	3.3	31.8	10.1	2.9	30.2	11.3	2.5	28.5	12.7	2.1

MODEL:YCAL0018EC

AIR TEMPERATURE ON - CONDENSER (°C)

LCWT (°C)	25.0			30.0			35.0			40.0			45.0			50.0		
	KW	KW	COP	KW	KW	COP	KW	KW	COP	KW	KW	COP	KW	KW	COP	KW	KW	COP
5.0	45.4	10.7	3.9	43.6	11.9	3.4	41.7	13.2	3.0	39.7	14.7	2.5	37.5	16.4	2.2	35.2	18.4	1.8
6.0	46.7	10.8	4.0	44.9	12.0	3.5	43.0	13.3	3.0	40.9	14.8	2.6	38.7	16.5	2.2	36.3	18.5	1.9
7.0	48.1	10.9	4.0	46.2	12.1	3.5	44.3	13.4	3.1	42.2	14.9	2.7	39.9	16.6	2.3	37.5	18.6	1.9
8.0	49.5	11.0	4.1	47.6	12.2	3.6	45.6	13.5	3.2	43.4	15.0	2.7	41.1	16.7	2.3	38.7	18.7	2.0
9.0	51.0	11.1	4.2	49.0	12.3	3.7	46.9	13.6	3.2	44.7	15.1	2.8	42.4	16.8	2.4	39.9	18.8	2.0
10.0	52.4	11.3	4.3	50.4	12.4	3.8	48.3	13.7	3.3	46.0	15.2	2.8	43.7	16.9	2.4	41.1	18.9	2.1
11.0	53.9	11.4	4.4	51.8	12.5	3.8	49.7	13.8	3.4	47.4	15.3	2.9	44.9	17.0	2.5	42.3	19.0	2.1

MODEL:YCAL0021EC

AIR TEMPERATURE ON - CONDENSER (°C)

LCWT (°C)	25.0			30.0			35.0			40.0			45.0			50.0		
	KW	KW	COP	KW	KW	COP	KW	KW	COP	KW	KW	COP	KW	KW	COP	KW	KW	COP
5.0	54.7	12.8	4.0	52.6	14.2	3.5	50.3	15.9	3.0	47.9	17.9	2.5	45.2	20.0	2.2	42.3	22.5	1.8
6.0	56.3	12.9	4.1	54.1	14.4	3.5	51.8	16.1	3.0	49.3	18.0	2.6	46.6	20.2	2.2	43.6	22.6	1.9
7.0	57.9	13.0	4.1	55.7	14.5	3.6	53.3	16.2	3.1	50.8	18.1	2.7	48.0	20.3	2.3	45.0	22.8	1.9
8.0	59.6	13.1	4.2	57.2	14.6	3.7	54.8	16.3	3.2	52.3	18.3	2.7	49.4	20.4	2.3	46.3	22.9	1.9
9.0	61.2	13.2	4.3	58.9	14.8	3.7	56.4	16.5	3.2	53.8	18.4	2.8	50.9	20.6	2.4	47.7	23.1	2.0
10.0	62.9	13.4	4.4	60.5	14.9	3.8	58.0	16.6	3.3	55.3	18.5	2.8	52.4	20.7	2.4	49.1	23.2	2.0
11.0	64.6	13.5	4.5	62.2	15.0	3.9	59.6	16.7	3.4	56.8	18.7	2.9	53.9	20.9	2.5	50.6	23.4	2.1

NOTES:

1. kW = Compressor Input Power
2. EER = Chiller EER (includes power from compressors, fans, and the control panels 0.8 kW)
3. LCWT = Leaving Chilled Water Temperature
4. Ratings are based upon 2.4 GPM cooler water per ton and 0.0001 fouling factor
5. Rated in accordance with ARI Standard 550/590-98
6. The shaded points are certified in accordance with ARI Standard 550/590-98

MODEL:YCAL0025EC**AIR TEMPERATURE ON - CONDENSER (°C)**

LCWT (°C)	25.0			30.0			35.0			40.0			45.0			50.0		
	KW	KW	COP	KW	KW	COP	KW	KW	COP	KW	KW	COP	KW	KW	COP	KW	KW	COP
5.0	67.0	15.8	3.6	64.7	17.3	3.2	62.1	19.1	2.8	59.3	21.1	2.5	56.2	23.4	2.1	52.9	25.9	1.8
6.0	69.1	15.9	3.7	66.7	17.4	3.3	64.0	19.2	2.9	61.2	21.2	2.5	58.1	23.5	2.2	54.7	26.0	1.9
7.0	71.3	15.9	3.8	68.7	17.5	3.4	66.0	19.3	3.0	63.1	21.3	2.6	59.9	23.6	2.3	56.5	26.1	1.9
8.0	73.4	16.0	3.9	70.8	17.6	3.4	68.0	19.3	3.0	65.0	21.4	2.7	61.8	23.6	2.3	58.3	26.2	2.0
9.0	75.6	16.1	4.0	72.9	17.6	3.5	70.0	19.4	3.1	67.0	21.4	2.7	63.7	23.7	2.4	60.1	26.3	2.1
10.0	77.9	16.2	4.1	75.1	17.7	3.6	72.1	19.5	3.2	69.0	21.5	2.8	65.6	23.8	2.5	62.0	26.4	2.1
11.0	80.2	16.3	4.2	77.3	17.8	3.7	74.2	19.6	3.3	71.0	21.6	2.9	67.6	23.9	2.5	63.9	26.4	2.2

MODEL:YCAL0027EC**AIR TEMPERATURE ON - CONDENSER (°C)**

LCWT (°C)	25.0			30.0			35.0			40.0			45.0			50.0		
	KW	KW	COP	KW	KW	COP	KW	KW	COP	KW	KW	COP	KW	KW	COP	KW	KW	COP
5.0	73.9	17.3	3.6	71.2	19.1	3.2	68.4	21.2	2.8	65.4	23.5	2.5	62.2	26.1	2.1	58.7	28.9	1.8
6.0	76.2	17.4	3.7	73.4	19.2	3.3	70.5	21.3	2.9	67.5	23.6	2.5	64.2	26.2	2.2	60.6	29.0	1.9
7.0	78.5	17.5	3.8	75.6	19.3	3.4	72.7	21.4	3.0	69.5	23.7	2.6	66.2	26.3	2.3	62.5	29.2	1.9
8.0	80.8	17.6	3.9	77.9	19.4	3.5	74.9	21.5	3.1	71.6	23.8	2.7	68.2	26.4	2.3	64.5	29.3	2.0
9.0	83.2	17.7	4.0	80.2	19.5	3.6	77.1	21.6	3.1	73.8	23.9	2.7	70.2	26.5	2.4	66.4	29.4	2.1
10.0	85.6	17.8	4.1	82.5	19.6	3.7	79.3	21.7	3.2	75.9	24.0	2.8	72.3	26.6	2.4	68.4	29.5	2.1
11.0	88.1	17.9	4.2	84.9	19.7	3.7	81.6	21.8	3.3	78.2	24.1	2.9	74.5	26.7	2.5	70.5	29.6	2.2

MODEL:YCAL0032EC**AIR TEMPERATURE ON - CONDENSER (°C)**

LCWT (°C)	25.0			30.0			35.0			40.0			45.0			50.0		
	KW	KW	COP	KW	KW	COP	KW	KW	COP	KW	KW	COP	KW	KW	COP	KW	KW	COP
5.0	86.2	20.5	3.7	83.0	22.8	3.2	79.7	25.3	2.8	76.2	28.1	2.5	72.4	31.2	2.1	68.4	34.6	1.8
6.0	88.7	20.6	3.8	85.5	22.9	3.3	82.1	25.5	2.9	78.5	28.3	2.5	74.7	31.4	2.2	70.5	34.8	1.9
7.0	91.4	20.8	3.8	88.0	23.1	3.4	84.6	25.6	3.0	80.9	28.4	2.6	76.9	31.6	2.2	72.6	35.0	1.9
8.0	94.0	20.9	3.9	90.6	23.2	3.5	87.0	25.7	3.0	83.3	28.6	2.6	79.2	31.7	2.3	74.8	35.2	2.0
9.0	96.8	21.1	4.0	93.2	23.4	3.5	89.6	25.9	3.1	85.7	28.8	2.7	81.5	31.9	2.3	77.0	35.4	2.0
10.0	99.5	21.2	4.1	95.9	23.5	3.6	92.2	26.1	3.2	88.2	28.9	2.8	83.9	32.1	2.4	79.3	35.6	2.1
11.0	102.4	21.4	4.2	98.6	23.7	3.7	94.8	26.2	3.2	90.7	29.1	2.8	86.3	32.3	2.5	81.5	35.8	2.1

NOTES:

1. kW = Compressor Input Power
2. EER = Chiller EER (includes power from compressors, fans, and the control panels 0.8 kW)
3. LCWT = Leaving Chilled Water Temperature
4. Ratings are based upon 2.4 GPM cooler water per ton and 0.0001 fouling factor
5. Rated in accordance with ARI Standard 550/590-98
6. The shaded points are certified in accordance with ARI Standard 550/590-98

Ratings - R-22 (50Hz - SI Units) - Cont.

MODEL: YCAL0041EC

AIR TEMPERATURE ON - CONDENSER (°C)

LCWT (°C)	25.0			30.0			35.0			40.0			45.0			50.0		
	KW	KW	COP	KW	KW	COP	KW	KW	COP	KW	KW	COP	KW	KW	COP	KW	KW	COP
5.0	107.8	24.3	3.9	103.7	27.1	3.4	99.6	30.3	3.0	95.2	33.9	2.6	90.4	38.1	2.2	85.1	42.8	1.9
6.0	111.0	24.5	4.0	106.9	27.3	3.5	102.6	30.5	3.0	98.1	34.1	2.6	93.3	38.2	2.3	87.8	43.0	1.9
7.0	114.2	24.7	4.1	110.0	27.5	3.6	105.7	30.6	3.1	101.1	34.3	2.7	96.1	38.4	2.3	90.6	43.2	2.0
8.0	117.5	24.9	4.2	113.2	27.6	3.7	108.8	30.8	3.2	104.1	34.5	2.8	99.1	38.6	2.4	93.4	43.3	2.0
9.0	120.8	25.1	4.3	116.4	27.9	3.7	112.0	31.0	3.3	107.2	34.6	2.8	102.0	38.8	2.4	96.3	43.5	2.1
10.0	124.2	25.3	4.4	119.7	28.1	3.8	115.2	31.2	3.3	110.3	34.8	2.9	105.0	39.0	2.5	99.2	43.7	2.1
11.0	127.6	25.5	4.5	123.1	28.3	3.9	118.4	31.4	3.4	113.5	35.0	3.0	108.1	39.2	2.6	102.2	43.9	2.2

MODEL: YCAL0045EC

AIR TEMPERATURE ON - CONDENSER (°C)

LCWT (°C)	25.0			30.0			35.0			40.0			45.0			50.0		
	KW	KW	COP	KW	KW	COP	KW	KW	COP	KW	KW	COP	KW	KW	COP	KW	KW	COP
5.0	116.7	26.7	3.9	112.2	29.7	3.4	107.4	33.1	3.0	102.2	36.9	2.6	96.7	41.3	2.2	90.6	46.3	1.8
6.0	120.2	26.9	4.0	115.6	29.9	3.5	110.7	33.3	3.0	105.4	37.1	2.6	99.7	41.5	2.2	93.5	46.5	1.9
7.0	123.7	27.1	4.1	119.0	30.1	3.6	114.0	33.5	3.1	108.6	37.3	2.7	102.8	41.7	2.3	96.5	46.7	1.9
8.0	127.2	27.3	4.2	122.4	30.3	3.7	117.3	33.7	3.2	111.9	37.6	2.7	106.0	41.9	2.4	99.6	46.9	2.0
9.0	130.8	27.6	4.2	125.9	30.6	3.7	120.7	33.9	3.3	115.2	37.8	2.8	109.2	42.2	2.4	102.7	47.1	2.0
10.0	134.4	27.8	4.3	129.4	30.8	3.8	124.2	34.2	3.3	118.6	38.0	2.9	112.4	42.4	2.5	105.8	47.3	2.1
11.0	138.1	28.1	4.4	133.0	31.1	3.9	127.7	34.4	3.4	122.0	38.2	2.9	115.7	42.6	2.5	109.0	47.6	2.2

MODEL: YCAL0051EC

AIR TEMPERATURE ON - CONDENSER (°C)

LCWT (°C)	25.0			30.0			35.0			40.0			45.0			50.0		
	KW	KW	COP	KW	KW	COP	KW	KW	COP	KW	KW	COP	KW	KW	COP	KW	KW	COP
5.0	134.2	31.6	3.9	129.2	35.1	3.4	123.9	39.0	2.9	118.2	43.4	2.5	112.0	48.2	2.2	105.3	53.6	1.9
6.0	138.2	31.9	3.9	133.1	35.3	3.5	127.7	39.2	3.0	121.8	43.6	2.6	115.5	48.5	2.2	108.7	53.9	1.9
7.0	142.3	32.1	4.0	137.1	35.5	3.5	131.5	39.4	3.1	125.5	43.8	2.7	119.1	48.7	2.3	112.1	54.1	2.0
8.0	146.4	32.3	4.1	141.1	35.8	3.6	135.4	39.6	3.2	129.3	44.0	2.7	122.7	48.9	2.4	115.6	54.3	2.0
9.0	150.6	32.5	4.2	145.2	36.0	3.7	139.3	39.9	3.2	133.1	44.3	2.8	126.4	49.1	2.4	119.2	54.6	2.1
10.0	154.9	32.8	4.3	149.3	36.2	3.8	143.4	40.1	3.3	137.0	44.5	2.9	130.1	49.4	2.5	122.8	54.8	2.1
11.0	159.2	33.0	4.4	153.5	36.5	3.9	147.4	40.4	3.4	140.9	44.7	2.9	134.0	49.6	2.5	126.5	55.1	2.2

NOTES:

1. kW = Compressor Input Power
2. EER = Chiller EER (includes power from compressors, fans, and the control panels 0.8 kW)
3. LCWT = Leaving Chilled Water Temperature
4. Ratings are based upon 2.4 GPM cooler water per ton and 0.0001 fouling factor
5. Rated in accordance with ARI Standard 550/590-98
6. The shaded points are certified in accordance with ARI Standard 550/590-98

MODEL: YCAL0055EC**AIR TEMPERATURE ON - CONDENSER (°C)**

LCWT (°C)	25.0			30.0			35.0			40.0			45.0			50.0		
	KW	KW	COP	KW	KW	COP	KW	KW	COP	KW	KW	COP	KW	KW	COP	KW	KW	COP
5.0	146.1	34.7	3.8	140.9	38.4	3.3	135.3	42.5	2.9	129.3	47.1	2.5	122.9	52.2	2.2	115.9	57.8	1.9
6.0	150.5	34.9	3.9	145.1	38.6	3.4	139.4	42.7	3.0	133.3	47.3	2.6	126.7	52.5	2.3	119.6	58.1	1.9
7.0	155.0	35.1	4.0	149.5	38.8	3.5	143.6	42.9	3.1	137.4	47.6	2.7	130.6	52.7	2.3	123.3	58.4	2.0
8.0	159.5	35.3	4.1	153.9	39.0	3.6	147.9	43.1	3.2	141.5	47.8	2.7	134.6	53.0	2.4	127.1	58.7	2.0
9.0	164.2	35.5	4.2	158.3	39.2	3.7	152.2	43.3	3.2	145.6	48.0	2.8	138.6	53.2	2.4	131.0	58.9	2.1
10.0	168.9	35.7	4.3	162.9	39.4	3.8	156.6	43.6	3.3	149.9	48.2	2.9	142.7	53.4	2.5	134.9	59.2	2.1
11.0	173.7	36.0	4.4	167.5	39.6	3.9	161.1	43.8	3.4	154.2	48.5	2.9	146.8	53.7	2.6	138.9	59.5	2.2

MODEL: YCAL0061EC**AIR TEMPERATURE ON - CONDENSER (°C)**

LCWT (°C)	25.0			30.0			35.0			40.0			45.0			50.0		
	KW	KW	COP	KW	KW	COP	KW	KW	COP	KW	KW	COP	KW	KW	COP	KW	KW	COP
5.0	170.1	41.1	3.8	163.9	45.5	3.3	157.4	50.5	2.9	150.5	56.0	2.5	143.0	62.2	2.2	134.7	69.0	1.9
6.0	175.2	41.3	3.9	168.8	45.8	3.4	162.2	50.7	3.0	155.1	56.3	2.6	147.5	62.5	2.2	139.0	69.4	1.9
7.0	180.3	41.6	4.0	173.8	46.1	3.5	167.0	51.1	3.0	159.8	56.7	2.6	152.0	62.9	2.3	143.3	69.8	2.0
8.0	185.6	41.9	4.1	178.9	46.4	3.6	171.9	51.4	3.1	164.6	57.0	2.7	156.6	63.3	2.3	147.8	70.2	2.0
9.0	190.9	42.2	4.1	184.0	46.7	3.6	176.9	51.7	3.2	169.4	57.3	2.8	161.2	63.6	2.4	152.2	70.6	2.0
10.0	196.4	42.5	4.2	189.3	47.0	3.7	182.0	52.0	3.3	174.3	57.6	2.8	165.9	64.0	2.4	156.7	71.0	2.1
11.0	201.9	42.8	4.3	194.7	47.3	3.8	187.2	52.3	3.3	179.3	58.0	2.9	170.7	64.3	2.5	161.3	71.4	2.1

MODEL: YCAL0065EC**AIR TEMPERATURE ON - CONDENSER (°C)**

LCWT (°C)	25.0			30.0			35.0			40.0			45.0			50.0		
	KW	KW	COP	KW	KW	COP	KW	KW	COP	KW	KW	COP	KW	KW	COP	KW	KW	COP
5.0	186.0	45.4	3.8	179.1	50.2	3.3	171.9	55.6	2.9	164.0	61.7	2.5	155.3	68.5	2.1	145.5	76.2	1.8
6.0	191.4	45.7	3.9	184.4	50.5	3.4	177.0	56.0	3.0	169.0	62.1	2.6	160.2	69.0	2.2	150.2	76.7	1.9
7.0	197.0	46.0	4.0	189.8	50.9	3.5	182.2	56.4	3.0	174.1	62.5	2.6	165.1	69.4	2.3	155.0	77.2	1.9
8.0	202.7	46.4	4.0	195.3	51.3	3.5	187.6	56.7	3.1	179.3	62.9	2.7	170.1	69.9	2.3	159.9	77.7	2.0
9.0	208.4	46.8	4.1	200.9	51.6	3.6	193.0	57.1	3.2	184.5	63.3	2.7	175.2	70.3	2.4	164.8	78.1	2.0
10.0	214.3	47.1	4.2	206.6	52.0	3.7	198.5	57.5	3.2	189.8	63.8	2.8	180.3	70.8	2.4	169.8	78.6	2.1
11.0	220.3	47.5	4.3	212.4	52.4	3.8	204.1	58.0	3.3	195.2	64.2	2.9	185.6	71.3	2.5	174.9	79.2	2.1

NOTES:

1. kW = Compressor Input Power
2. EER = Chiller EER (includes power from compressors, fans, and the control panels 0.8 kW)
3. LCWT = Leaving Chilled Water Temperature
4. Ratings are based upon 2.4 GPM cooler water per ton and 0.0001 fouling factor
5. Rated in accordance with ARI Standard 550/590-98
6. The shaded points are certified in accordance with ARI Standard 550/590-98

Part Load Ratings - 60 Hz R-22 (English Units)

YCAL0012EC				
% FULL LOAD DISPL.	TONS	KW	Ambient °F	UNIT EER
100	9.7	11.1	95.0	9.6
50	5.6	4.0	69.5	15
IPLV: 13.8 EER				

YCAL0025EC				
% FULL LOAD DISPL.	TONS	KW	Ambient °F	UNIT EER
100	21.7	24.1	95	9.6
50	12.3	9	68.9	14
IPLV: 13.0 EER				

YCAL0018EC				
% FULL LOAD DISPL.	TONS	KW	Ambient °F	UNIT EER
100	14.5	17.2	95.0	9.6
50	8.2	6.2	68.8	14.6
IPLV: 13.4 EER				

YCAL0027EC				
% FULL LOAD DISPL.	TONS	KW	Ambient °F	UNIT EER
100	23.9	26.9	95	9.6
47	12.4	8.7	66.2	14.6
IPLV: 13.4 EER				

YCAL0021EC				
% FULL LOAD DISPL.	TONS	KW	Ambient °F	UNIT EER
100	17.4	20.8	95.0	9.6
50	10.0	7.6	69.4	14.8
IPLV: 13.6 EER				

YCAL0032EC				
% FULL LOAD DISPL.	TONS	KW	Ambient °F	UNIT EER
100	28	32	95	9.6
50	16	11.4	69.3	14.9
IPLV: 13.7 EER				

YCAL0041				
% FULL LOAD DISPL.	TONS	KW	Ambient °F	UNIT EER
100.0	35.1	38.2	95.0	9.6
75.0	28.3	24.5	83.4	11.3
50.0	20.3	14.0	69.7	14.5
25.0	10.3	6.0	55.0	16.6
IPLV: 13.9 EER				

YCAL0055				
% FULL LOAD DISPL.	TONS	KW	Ambient °F	UNIT EER
100.0	47.6	52.8	95.0	9.6
73.5	37.2	32.3	82.0	11.5
47.0	25.0	17.2	66.5	14.6
23.5	12.4	7.8	55.0	15.8
IPLV: 13.6 EER				

YCAL0045				
% FULL LOAD DISPL.	TONS	KW	Ambient °F	UNIT EER
100.0	37.8	41.8	95.0	9.6
73.2	30.2	25.9	83.0	11.5
50.0	22.1	15.5	70.0	14.5
23.2	10.5	6.1	55.0	16.6
IPLV: 14.0 EER				

YCAL0061				
% FULL LOAD DISPL.	TONS	KW	Ambient °F	UNIT EER
100.0	55.6	62.9	95.0	9.6
69.3	42.3	35.8	80.7	11.9
46.2	30.2	20.4	67.6	15.2
23.1	15.3	9.0	55.0	17.1
IPLV: 14.2 EER				

YCAL0051				
% FULL LOAD DISPL.	TONS	KW	Ambient °F	UNIT EER
100.0	43.6	48.7	95.0	9.6
69.2	33.7	28.3	81.4	11.9
48.3	24.3	17.1	68.5	14.6
20.9	13.0	7.1	55.0	18.3
IPLV: 14.3 EER				

YCAL0065				
% FULL LOAD DISPL.	TONS	KW	Ambient °F	UNIT EER
100.0	61.0	69.5	95.0	9.6
71.5	48.3	41.0	82.5	12.1
50.0	35.3	25.8	69.7	14.6
21.5	16.0	9.1	55.0	17.9
IPLV: 14.5 EER				

Part Load Ratings - 60 Hz R-22 (SI)

YCAL0041				
% FULL LOAD DISPL.	KW	Comp KW	Ambient °C	UNIT COP
100.0	123.4	38.2	35.0	2.8
75.0	99.4	24.5	28.5	3.3
50.0	71.4	14.0	21.0	4.2
25.0	36.2	6.0	12.8	4.9
IPLV: 4.1 COP				

YCAL0045				
% FULL LOAD DISPL.	KW	Comp KW	Ambient °C	UNIT COP
100.0	132.8	41.8	35.0	2.8
73.2	106.2	25.9	28.3	3.4
50.0	77.6	15.5	21.1	4.2
23.2	36.8	6.1	12.8	4.9
IPLV: 4.1 COP				

YCAL0051				
% FULL LOAD DISPL.	KW	Comp KW	Ambient °C	UNIT COP
100.0	153.2	48.7	35.0	2.8
69.2	118.4	28.3	27.4	3.5
48.3	85.5	17.1	20.3	4.3
20.9	45.6	7.1	12.8	5.4
IPLV: 4.2 COP				

YCAL0055				
% FULL LOAD DISPL.	KW	Comp KW	Ambient °C	UNIT COP
100.0	167.4	52.8	35.0	2.8
73.5	131.0	32.3	27.8	3.4
47.0	87.8	17.2	19.2	4.3
23.5	43.7	7.8	12.8	4.6
IPLV: 4.0 COP				

YCAL0061				
% FULL LOAD DISPL.	KW	Comp KW	Ambient °C	UNIT COP
100.0	195.4	62.9	35.0	2.8
69.3	148.9	35.8	27.1	3.5
46.2	106.2	20.4	19.8	4.5
23.1	53.8	9.0	12.8	5.0
IPLV: 4.2 COP				

YCAL0065				
% FULL LOAD DISPL.	KW	Comp KW	Ambient °C	UNIT COP
100.0	214.6	69.5	35.0	2.8
71.5	169.7	41.0	28.0	3.6
50.0	124.2	25.8	21.0	4.3
21.5	56.4	9.1	12.8	5.3
IPLV: 4.2 COP				

Part Load Ratings - 50 Hz R-22 (English Units)

YCAL0012EC				
% FULL LOAD DISPL.	TONS	KW	Ambient °F	UNIT EER
100	8.3	8.8	95	10.2
50	4.8	3.1	69.4	16
IPLV: 14.6 EER				

YCAL0018EC				
% FULL LOAD DISPL.	TONS	KW	Ambient °F	UNIT EER
100	12.5	13.3	95	10.4
50	7	4.7	68.5	16
IPLV: 14.7 EER				

YCAL0021EC				
% FULL LOAD DISPL.	TONS	KW	Ambient °F	UNIT EER
100	15	16.1	95	10.5
50	8.6	5.7	69.2	16.5
IPLV: 15.1 EER				

YCAL0041				
% FULL LOAD DISPL.	TONS	KW	Ambient °F	EER
100.0	29.8	30.6	95.0	10.6
75.0	23.9	19.2	83.3	12.8
50.0	17.2	10.8	69.6	16.7
25.0	8.9	4.4	55.0	20.4
IPLV: 16.2 EER				

YCAL0045				
% FULL LOAD DISPL.	TONS	KW	Ambient °F	EER
100.0	32.1	33.4	95.0	10.5
73.2	25.4	20.2	82.5	13.0
50.0	18.4	11.8	69.3	16.5
23.2	9.0	4.5	55.0	20.3
IPLV: 16.1 EER				

YCAL0051				
% FULL LOAD DISPL.	TONS	KW	Ambient °F	EER
100.0	37.0	39.4	95.0	10.4
69.2	28.4	22.3	81.0	13.3
48.3	20.2	13.3	67.7	16.2
20.9	10.0	5.2	55.0	19.9
IPLV: 15.7 EER				

YCAL0025EC				
% FULL LOAD DISPL.	TONS	KW	Ambient °F	UNIT EER
100	18.6	19.2	95	10
50	10.4	7.1	68.6	14.6
IPLV: 13.5 EER				

YCAL0027EC				
% FULL LOAD DISPL.	TONS	KW	Ambient °F	UNIT EER
100	20.5	21.4	95	10.1
47	10.5	6.9	65.9	15.1
IPLV: 13.9 EER				

YCAL0032EC				
% FULL LOAD DISPL.	TONS	KW	Ambient °F	UNIT EER
100	23.8	25.6	95	10
50	13.5	8.9	68.9	15.5
IPLV: 14.2 EER				

YCAL0055				
% FULL LOAD DISPL.	TONS	KW	Ambient °F	EER
100.0	40.4	42.8	95.0	10.4
73.5	31.5	26.0	81.8	12.7
47.0	21.1	13.7	66.2	16.1
23.5	10.5	6.2	55.0	17.6
IPLV: 15.0 EER				

YCAL0061				
% FULL LOAD DISPL.	TONS	KW	Ambient °F	EER
100.0	47.0	51.0	95.0	10.3
69.3	35.7	28.8	80.5	13.1
46.2	25.3	16.2	67.3	16.7
23.1	12.9	7.0	55.0	19.3
IPLV: 15.7 EER				

YCAL0065				
% FULL LOAD DISPL.	TONS	KW	Ambient °F	EER
100.0	51.7	56.3	95.0	10.3
71.5	40.7	32.9	82.3	13.3
50.0	29.7	20.5	69.5	15.9
21.5	13.5	7.1	55.0	20.1
IPLV: 15.9 EER				

Part Load Ratings - 50 Hz R-22 (SI)

YCAL0041				
% FULL LOAD DISPL.	KW	Comp KW	Ambient °C	UNIT COP
100.0	104.7	30.6	35.0	3.1
75.0	84.2	19.2	28.5	3.8
50.0	60.4	10.8	20.9	4.9
25.0	31.2	4.4	12.8	6.0
IPLV: 4.8 COP				

YCAL0045				
% FULL LOAD DISPL.	KW	Comp KW	Ambient °C	UNIT COP
100.0	112.9	33.4	35.0	3.1
73.2	89.4	20.2	28.1	3.8
50.0	64.6	11.8	20.7	4.8
23.2	31.5	4.5	12.8	6.0
IPLV: 4.7 COP				

YCAL0051				
% FULL LOAD DISPL.	KW	Comp KW	Ambient °C	UNIT COP
100.0	130.2	39.4	35.0	3.1
69.2	99.9	22.3	27.2	3.9
48.3	70.9	13.3	19.8	4.7
20.9	35.2	5.2	12.8	5.8
IPLV: 4.6 COP				

YCAL0055				
% FULL LOAD DISPL.	KW	Comp KW	Ambient °C	UNIT COP
100.0	142.2	42.8	35.0	3.0
73.5	110.9	26.0	27.7	3.7
47.0	74.1	13.7	19.0	4.7
23.5	36.9	6.2	12.8	5.2
IPLV: 4.4 COP				

YCAL0061				
% FULL LOAD DISPL.	KW	Comp KW	Ambient °C	UNIT COP
100.0	165.4	51.0	35.0	3.0
69.3	125.5	28.8	27.0	3.8
46.2	89.1	16.2	19.6	4.9
23.1	45.4	7.0	12.8	5.7
IPLV: 4.6 COP				

YCAL0065				
% FULL LOAD DISPL.	KW	Comp KW	Ambient °C	UNIT COP
100.0	181.7	56.3	35.0	3.0
71.5	143.1	32.9	27.9	3.9
50.0	104.3	20.5	20.8	4.7
21.5	47.5	7.1	12.8	5.9
IPLV: 4.7 COP				

Physical Data

60Hz

YCAL Model No.	Dimension			General Unit Data								Nominal Compressor Capacity					
	Length	Width	Height	Nominal Tons R-22	Number of Refrigerant Circuits	Refrigerant Charge, Operating, R-22 (lbs)	Oil Charge, gallons	Shipping Weight		Operating Weight		Circuit 1			Circuit 2		
						ckt1/ckt2	ckt1/ckt2	Aluminum Fin Coils, lbs	Copper Fin Coils, lbs	Aluminum Fin Coils, lbs	Copper Fin Coils, lbs	Compressor 1	Compressor 2	Compressor 3	Compressor 4	Compressor 5	Compressor 6
0012	109.79	44.70	46.06	9.7	1	20/-	0.89/-	1361	1470	1385	1494	6	6				
0018	109.79	44.70	46.06	14.5	1	25/-	1.7/-	1454	1597	1481	1624	8	8				
0021	109.79	44.70	46.06	17.8	1	30/-	1.7/-	1567	1781	1597	1811	10	10				
0025	118.57	44.70	50.00	21.7	1	40/-	2.2/-	1945	2151	1982	2188	13	13				
0027	118.57	44.70	50.00	23.9	1	45/-	2.2/-	1977	2183	2014	2220	15	13				
0032	118.57	44.70	50.00	28.0	1	50/-	2.2/-	2034	2240	2077	2283	15	15				
0041	144.81	90.56	47.75	34.9	2	35/35	1.7/1.7	2942	3300	2967	3325	10	10		10	10	
0045	144.81	90.56	47.75	38.0	2	40/35	1.7/1.7	2968	3326	3001	3359	12	12		10	10	
0051	144.81	90.56	47.75	43.4	2	40/45	1.7/2.2	3448	3985	3480	4017	12	12		13	15	
0055	144.81	90.56	62.63	47.4	2	50/50	2.2/2.2	3558	4035	3595	4073	15	13		13	15	
0061	144.81	90.56	62.63	56.0	2	55/55	2.3/2.2	3863	4436	3908	4481	20	15		15	15	
0065	153.63	90.56	62.63	60.1	2	60/55	2.3/2.2	4097	4703	4142	4748	20	20		15	15	

50Hz

Ycal Model No.	Dimension			General Unit Data								Nominal Compressor Capacity					
	Length	Width	Height	Nominal Tons, R-22	Number Of Refrigerant Circuits	Refrigerant Charge, Operating, R-22 (Lbs)	Oil Charge, Gallons	Shipping Weight		Operating Weight		Circuit 1			Circuit 2		
						Ckt1/Ckt2	Ckt1/Ckt2	Aluminum Fin Coils, Lbs	Copper Fin Coils, Lbs	Aluminum Fin Coils, Lbs	Copper Fin Coils, Lbs	Compressor 1	Compressor 2	Compressor 3	Compressor 4	Compressor 5	Compressor 6
0012	109.79	44.7	46.1	8.2	1	20	0.9	1361	1470	1385	1494	5	5				
0018	109.79	44.7	46.1	12.3	1	25	1.7	1454	1597	1481	1624	7	7				
0021	109.79	44.7	46.1	15.1	1	30	1.7	1567	1781	1597	1811	8	8				
0025	118.57	44.7	50	18.4	1	40	2.2	1945	2151	1982	2188	11	11				
0027	118.57	44.7	50	20.3	1	45	2.2	1977	2183	2014	2220	13	11				
0032	118.57	44.7	50	23.8	1	50	2.2	2034	2240	2077	2283	13	13				
0041	145.75	91.2	47.75	29.6	2	35/35	1.7/1.7	2942	3300	2967	3325	8	8		8	8	
0045	145.75	91.2	47.75	32.3	2	40/35	1.7/1.7	2968	3326	3001	3359	10	10		8	8	
0051	145.75	91.2	47.75	37.3	2	40/45	1.7/2.2	3448	3985	3480	4017	10	10		11	13	
0055	145.75	91.2	62.73	40.2	2	50/50	2.2/2.2	3558	4035	3595	4073	13	11		11	13	
0061	145.75	91.2	62.73	47.6	2	55/55	2.3/2.2	3863	4436	3908	4481	17	13		13	13	
0065	154.56	91.2	62.73	50.9	2	60/55	2.3/2.2	4097	4703	4142	4748	17	17		13	13	

60Hz

Condenser			Condenser Fans, Low Sound				Condenser Fans, Ultra Quiet				Evaporator					
Total Face Area ft ²	Number of Rows	Fins per Inch	Number of Fans	Fan Power hp/fan	Fan RPM	Total Chiller CFM	Number of Fans	Fan hp	Fan RPM	Total Chiller CFM	Water Volume, gallons	Maximum Water Side Pressure, PSIG	Maximum Refrigerant Side Pressure, PSIG	Minimum Chiller Water Flow Rate, gpm	Maximum Chiller Water Flow Rate, gpm	Nominal Water Connections Size, inches
	Ckt. 1/Ckt. 2		ckt1/ckt2				ckt1/ckt2									
34.7	2/-	13	2/-	0.5	1100	13000	2/-				2.9	300	450	10	150	2
34.7	2/-	17	2/-	0.5	1100	13000	2/-				3.3	300	450	10	150	2
34.7	3/-	17	2/-	0.5	1100	13000	2/-				3.6	300	450	10	150	2
43.5	3/-	17	2/-	1.5	1140	24000	2/-	2	838	24000	4.5	300	450	10	150	2
43.5	3/-	17	2/-	1.5	1140	24000	2/-	2	838	24000	4.5	300	450	10	150	2
43.5	3/-	17	2/-	1.5	1140	24000	2/-	2	838	24000	5.2	300	450	10	150	2
87.0	2/2	17	2/2	2	1140	47400	2/2	2	838	47400	2.7	300	450	40	200	3
87.0	2/2	17	2/2	2	1140	47400	2/2	2	838	47400	3.5	300	450	40	200	3
87.0	3/-	17	2/2	2	1140	47400	2/2	2	838	47400	3.5	300	450	40	200	3
116.0	2/2	17	2/2	2	1140	52000	2/2	2	838	52000	4.1	300	450	60	300	3
116.0	3/-	17	2/2	2	1140	52000	2/2	2	838	52000	4.9	300	450	60	300	3
128.0	3/-	13	2/2	2	1140	52000	2/2	2	838	52000	4.9	300	450	60	300	3

50Hz

Condenser			Condenser Fans, Low Sound				Condenser Fans, Ultra Quiet				Evaporator					
Total Face Area Ft ²	Number Of Rows	Fins Per Inch	Number Of Fans	Fan Power Hp/fan	Fan Rpm	Total Chiller Cfm	Number Of Fans	Fan Hp	Fan Rpm	Total Chiller Cfm	Water Volume, Gallons	Maximum Water Side Pressure, Psig	Maximum Refrigerant Side Pressure, Psig	Minimum Chiller Water Flow Rate, Gpm	Maximum Chiller Water Flow Rate, Gpm	Nominal Water Connections Size, Inches
	Ckt. 1/Ckt. 2		Ckt1/Ckt2				Ckt1/Ckt2									
34.7	2	13	2	0.3	920	10833					2.9	300	450	10	150	2
34.7	2	17	2	0.3	920	10833					3.3	300	450	10	150	2
34.7	3	17	2	0.3	920	10833					3.6	300	450	10	150	2
43.5	3	17	2	0.9	950	20000		1.2	698	20000	4.5	300	450	10	150	2
43.5	3	17	2	0.9	950	20000		1.2	698	20000	4.5	300	450	10	150	2
43.5	3	17	2	0.9	950	20000		1.2	698	20000	5.2	300	450	10	150	2
87.0	2/2	17	2/2	1.2	950	39500	2/2	1.2	698	39500	2.7	300	450	40	200	3
87.0	2/2	17	2/2	1.2	950	39500	2/2	1.2	698	39500	3.5	300	450	40	200	3
87.0	3/3	17	2/2	1.2	950	39500	2/2	1.2	698	39500	3.5	300	450	40	200	3
116.0	2/2	17	2/2	1.2	950	43333	2/2	1.2	698	43333	4.1	300	450	60	300	3
116.0	3/2	17	2/2	1.2	950	43333	2/2	1.2	698	43333	4.9	300	450	60	300	3
128.0	3/3	13	2/2	1.2	950	43333	2/2	1.2	698	43333	4.9	300	450	60	300	3

Sound Data

SINGLE CIRCUIT UNITS

60Hz Line Frequency

LOW NOISE FAN (STANDARD)

	63	125	250	500	1000	2000	4000	8000	DBA
YCAL0012	83	85	85	86	83	76	69	64	87
YCAL0018	85	86	86	86	84	77	70	67	88
YCAL0021	86	86	86	86	84	77	71	68	88
YCAL0025	91	91	92	90	85	81	77	74	91
YCAL0027	91	91	92	90	85	81	77	74	91
YCAL0032	91	91	92	90	85	81	77	74	91

60Hz Line Frequency

LOW NOISE FAN WITH COMPRESSOR SOUND BLANKETS

	63	125	250	500	1000	2000	4000	8000	DBA
YCAL0012	83	85	85	86	83	76	69	62	87
YCAL0018	85	86	86	86	83	76	69	63	87
YCAL0021	86	86	86	86	83	76	69	64	87
YCAL0025	91	91	92	89	84	80	76	73	91
YCAL0027	91	91	92	89	84	80	76	73	91
YCAL0032	91	91	92	89	84	80	76	73	91

60Hz Line Frequency

ULTRA QUIET FAN (OPTIONAL)

	63	125	250	500	1000	2000	4000	8000	DBA
YCAL0025	93	90	88	87	84	80	76	74	89
YCAL0027	93	90	88	87	84	80	76	74	89
YCAL0032	93	90	88	87	84	80	76	74	89

60Hz Line Frequency

ULTRA QUIET FAN WITH COMPRESSOR SOUND BLANKETS

	63	125	250	500	1000	2000	4000	8000	DBA
YCAL0025	93	90	88	86	82	78	74	73	88
YCAL0027	93	90	88	86	82	78	74	73	88
YCAL0032	93	90	88	86	82	78	74	73	88

SINGLE CIRCUIT UNITS

50Hz Line Frequency

LOW NOISE FAN (STANDARD)

	63	125	250	500	1000	2000	4000	8000	DBA
YCAL0012	82	84	84	84	79	71	64	61	84
YCAL0018	83	84	85	84	79	72	65	64	85
YCAL0021	84	84	85	85	80	72	66	66	85
YCAL0025	87	88	88	86	82	78	74	71	88
YCAL0027	87	88	88	86	82	78	74	71	88
YCAL0032	87	88	88	86	82	78	74	71	88

50Hz Line Frequency

LOW NOISE FAN WITH COMPRESSOR SOUND BLANKETS

	63	125	250	500	1000	2000	4000	8000	DBA
YCAL0012	82	84	84	84	79	70	64	60	84
YCAL0018	83	84	85	84	79	70	64	61	84
YCAL0021	84	84	85	84	79	71	64	62	84
YCAL0025	87	88	88	86	81	76	72	69	87
YCAL0027	87	88	88	86	81	76	72	69	87
YCAL0032	87	88	88	86	81	76	72	69	87

50Hz Line Frequency

ULTRA QUIET FAN (OPTIONAL)

	63	125	250	500	1000	2000	4000	8000	DBA
YCAL0025	89	87	85	84	81	77	73	71	86
YCAL0027	89	87	85	84	81	77	73	71	86
YCAL0032	89	87	85	84	81	77	73	71	86

50Hz Line Frequency

ULTRA QUIET FAN WITH COMPRESSOR SOUND BLANKETS

	63	125	250	500	1000	2000	4000	8000	DBA
YCAL0025	89	87	85	82	79	74	71	69	84
YCAL0027	89	87	85	82	79	74	71	69	84
YCAL0032	89	87	85	82	79	74	71	69	84

Sound Data - Cont.

DUAL CIRCUIT UNITS

60Hz Line Frequency

LOW NOISE FAN (STANDARD) R-22

	63	125	250	500	1000	2000	4000	8000	dBA
YCAL0041	92	91	92	90	86	81	77	74	92
YCAL0045	92	91	92	90	86	81	77	74	92
YCAL0051	91	92	92	91	87	82	78	75	92
YCAL0055	93	95	95	93	90	85	81	77	95
YCAL0061	93	95	95	93	90	86	82	77	95
YCAL0065	94	94	95	93	90	86	82	77	95

60Hz Line Frequency

LOW NOISE FAN WITH COMPRESSOR SOUND BLANKETS INSTALLED R-22

	63	125	250	500	1000	2000	4000	8000	dBA
YCAL0041	92	91	92	90	86	81	77	73	91
YCAL0045	92	91	92	90	86	81	77	73	91
YCAL0051	91	92	92	90	86	81	77	73	91
YCAL0055	93	95	95	93	89	84	80	76	94
YCAL0061	93	95	95	93	89	84	80	76	94
YCAL0065	94	94	95	93	89	84	80	75	94

60Hz Line Frequency

ULTRA QUIET FAN (OPTIONAL) R-22

	63	125	250	500	1000	2000	4000	8000	dBA
YCAL0041	94	88	88	87	83	79	75	74	88
YCAL0045	94	88	88	87	83	79	75	74	88
YCAL0051	94	90	89	88	84	80	76	75	90
YCAL0055	96	93	91	90	87	83	79	77	92
YCAL0061	96	93	91	90	87	84	80	77	92
YCAL0065	96	92	91	90	87	84	81	77	92

60Hz Line Frequency

Ultra Quiet Fan with compressor sound blankets installed R-22

	63	125	250	500	1000	2000	4000	8000	dBA
YCAL0041	94	88	88	85	82	77	74	73	87
YCAL0045	94	88	88	85	82	77	74	73	87
YCAL0051	94	90	89	86	83	78	74	73	88
YCAL0055	96	93	91	89	85	81	77	76	91
YCAL0061	96	93	91	89	85	81	78	76	91
YCAL0065	96	92	91	89	86	81	78	75	91

DUAL CIRCUIT UNITS**50Hz Line Frequency****LOW NOISE FAN (STANDARD) R-22**

	63	125	250	500	1000	2000	4000	8000	dBA
YCAL0041	88	87	88	87	83	78	74	71	88
YCAL0045	88	87	88	87	83	78	74	71	88
YCAL0051	88	89	89	87	83	79	75	72	89
YCAL0055	89	92	92	90	86	82	78	74	91
YCAL0061	90	91	91	90	86	82	78	74	92
YCAL0065	90	91	91	90	86	83	79	73	92

50Hz Line Frequency**LOW NOISE FAN WITH COMPRESSOR SOUND BLANKETS INSTALLED R-22**

	63	125	250	500	1000	2000	4000	8000	dBA
YCAL0041	88	87	88	86	82	77	73	69	87
YCAL0045	88	87	88	86	82	77	73	69	87
YCAL0051	88	89	89	86	82	77	73	69	88
YCAL0055	89	92	92	89	85	80	76	72	90
YCAL0061	90	91	91	89	85	80	76	72	90
YCAL0065	90	91	91	89	85	80	77	72	90

50Hz Line Frequency**ULTRA QUIET FAN (OPTIONAL) R-22**

	63	125	250	500	1000	2000	4000	8000	dBA
YCAL0041	90	84	84	84	80	75	72	71	85
YCAL0045	90	84	84	84	80	75	72	71	85
YCAL0051	90	88	86	85	81	78	73	72	87
YCAL0055	92	90	88	87	84	80	76	74	89
YCAL0061	92	90	88	87	84	81	77	74	89
YCAL0065	92	89	87	87	84	81	78	73	89

50Hz Line Frequency**Ultra Quiet Fan with compressor sound blankets installed R-22**

	63	125	250	500	1000	2000	4000	8000	dBA
YCAL0041	90	84	84	82	78	73	70	69	84
YCAL0045	90	84	84	82	78	73	70	69	84
YCAL0051	90	88	86	82	79	74	71	69	84
YCAL0055	92	90	88	85	82	77	74	72	87
YCAL0061	92	90	88	85	82	77	74	72	87
YCAL0065	92	89	87	85	82	77	74	72	87

Dimensions - YCAL0012 (English)

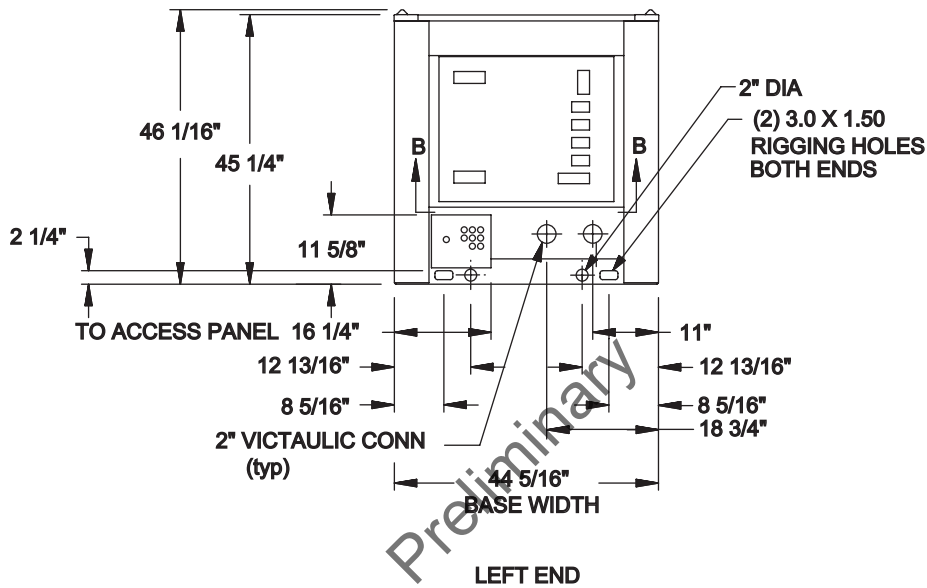
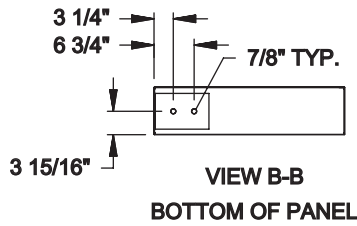

POWER: SINGLE POINT SUPPLY WITH TERMINAL BLOCK

NOTE:

Placement on a level surface of free of obstructions (including snow, for winter operation) or air circulation ensures rated performance, reliable operation, and ease of maintenance. Site restrictions may compromise minimum clearances indicated below, resulting in unpredictable airflow patterns and possible diminished performance. YORK's unit controls will optimize operation without nuisance high-pressure safety cutouts; however, the system designer must consider potential performance degradation. Recommended minimum clearances: front to wall – 6"; rear to wall – 6"; cooler end to wall – 4'0"; coil end to wall - 6"; top – no obstructions allowed; distance between adjacent units – 10'. No more than one adjacent wall may be higher than the unit. 1" nominal deflection isolators (not shown) will increase overall unit height by 6".

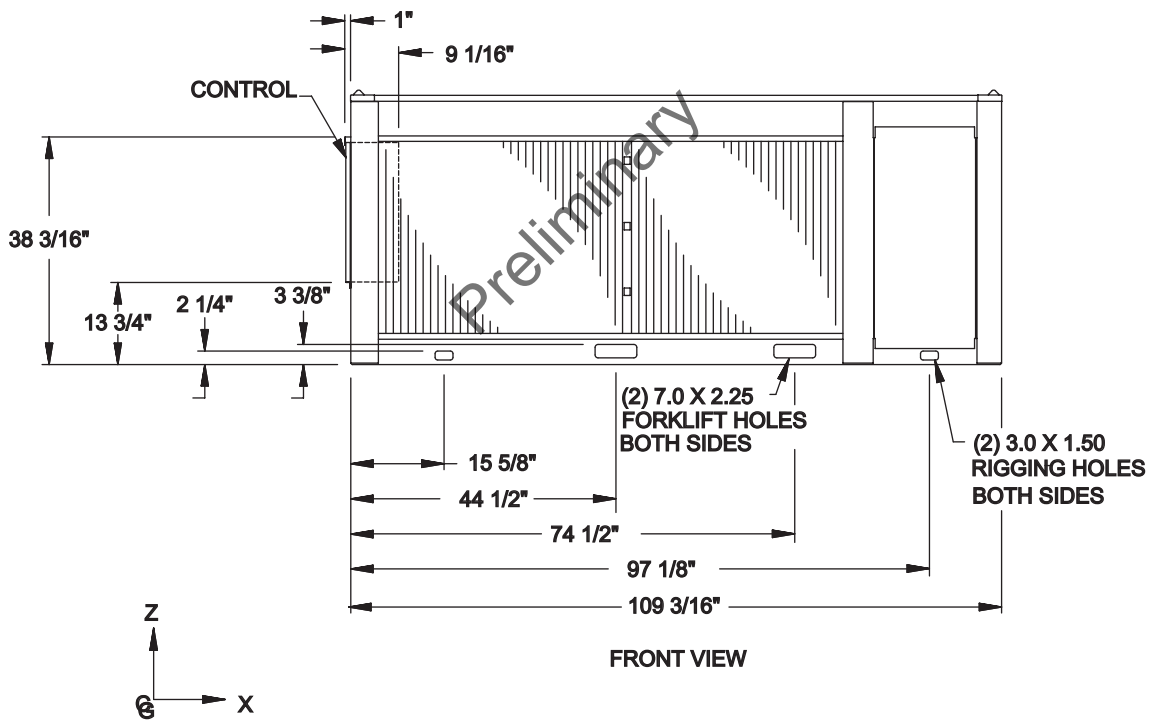
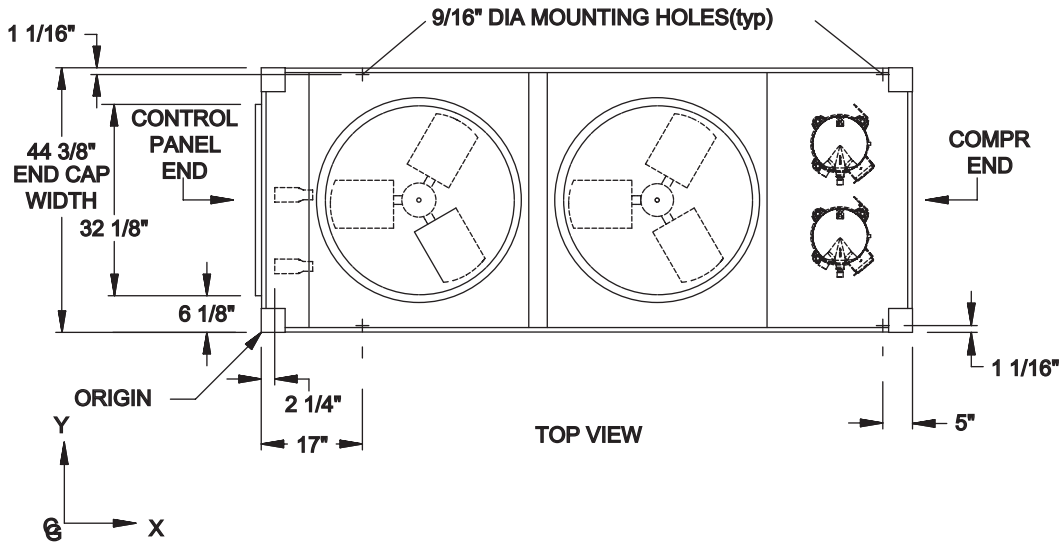

Dimensions - YCAL0018 (English)

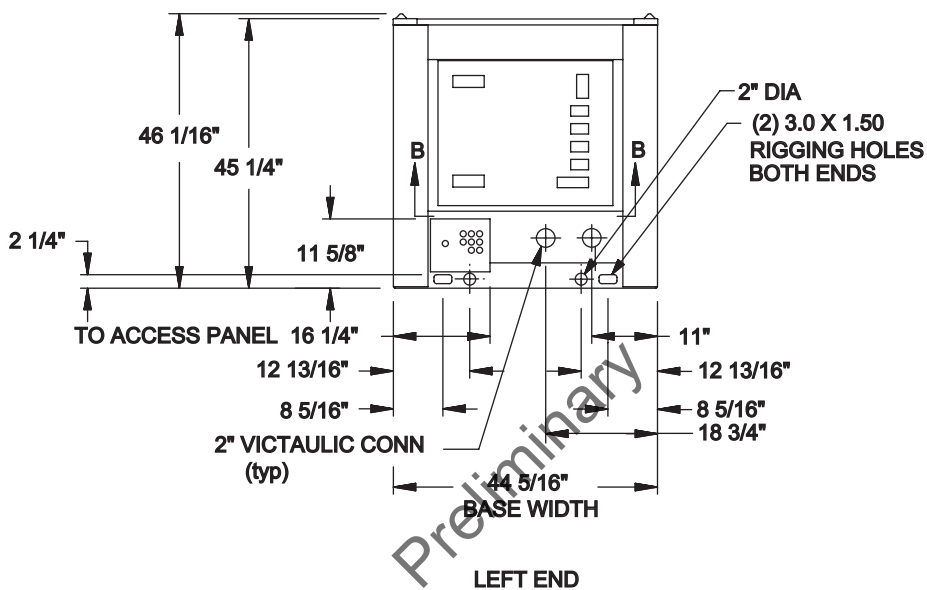
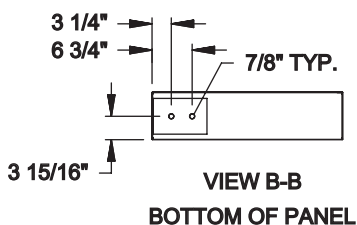

POWER: SINGLE POINT SUPPLY WITH TERMINAL BLOCK

NOTE:

Placement on a level surface of free of obstructions (including snow, for winter operation) or air circulation ensures rated performance, reliable operation, and ease of maintenance. Site restrictions may compromise minimum clearances indicated below, resulting in unpredictable airflow patterns and possible diminished performance. YORK's unit controls will optimize operation without nuisance high-pressure safety cutouts; however, the system designer must consider potential performance degradation. Recommended minimum clearances: front to wall - 6"; rear to wall - 6"; cooler end to wall - 4'0"; coil end to wall - 6"; top - no obstructions allowed; distance between adjacent units - 10". No more than one adjacent wall may be higher than the unit. 1" nominal deflection isolators (not shown) will increase overall unit height by 6".

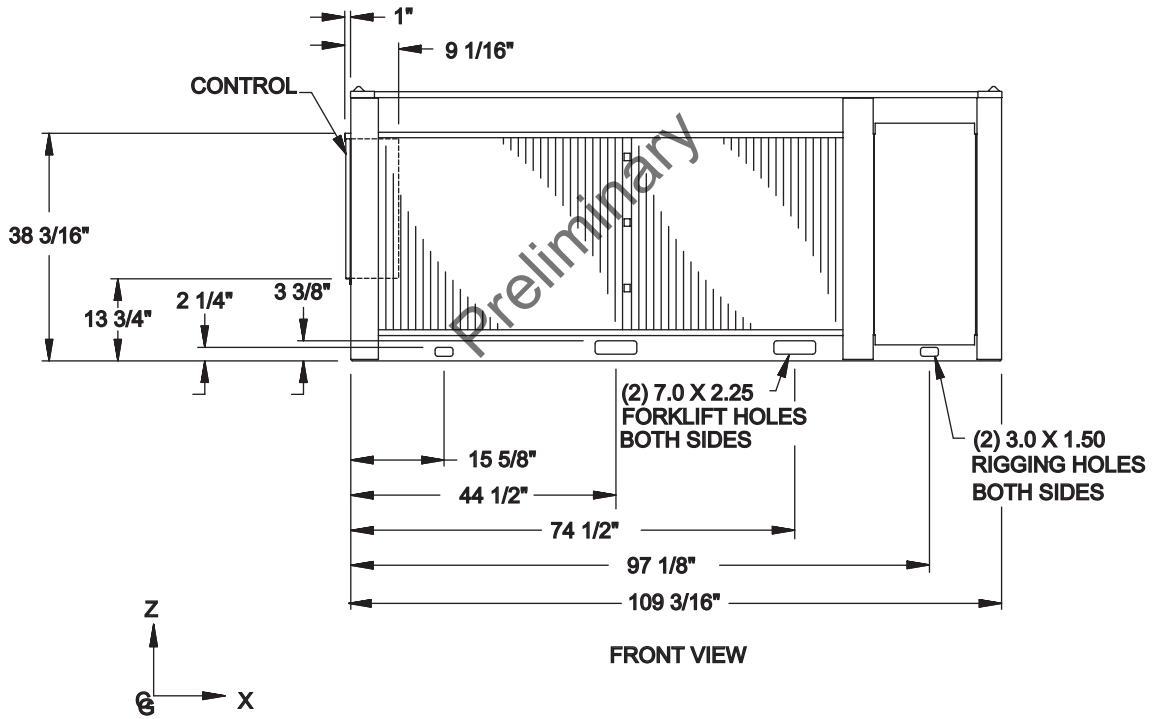
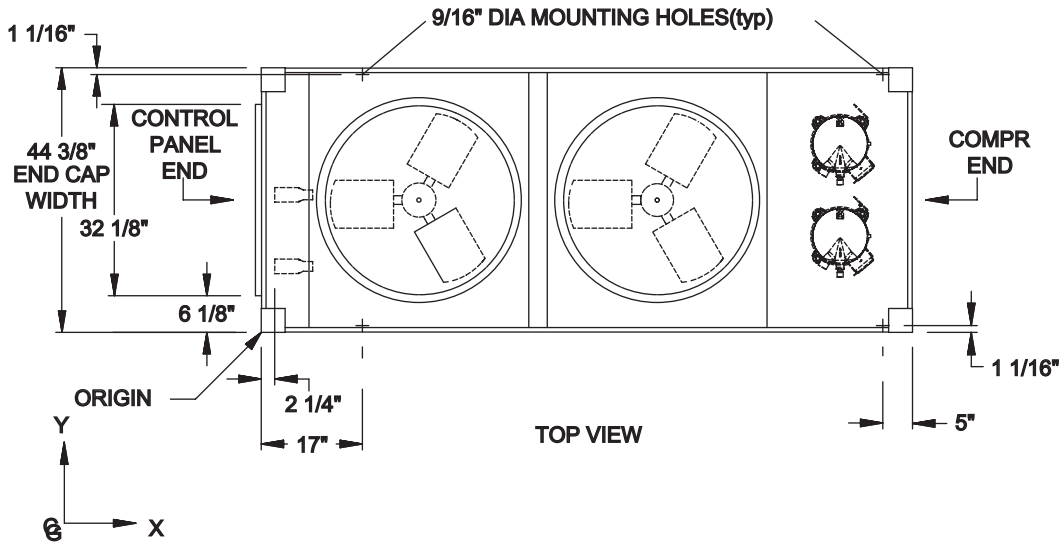

Dimensions - YCAL0021 (English)

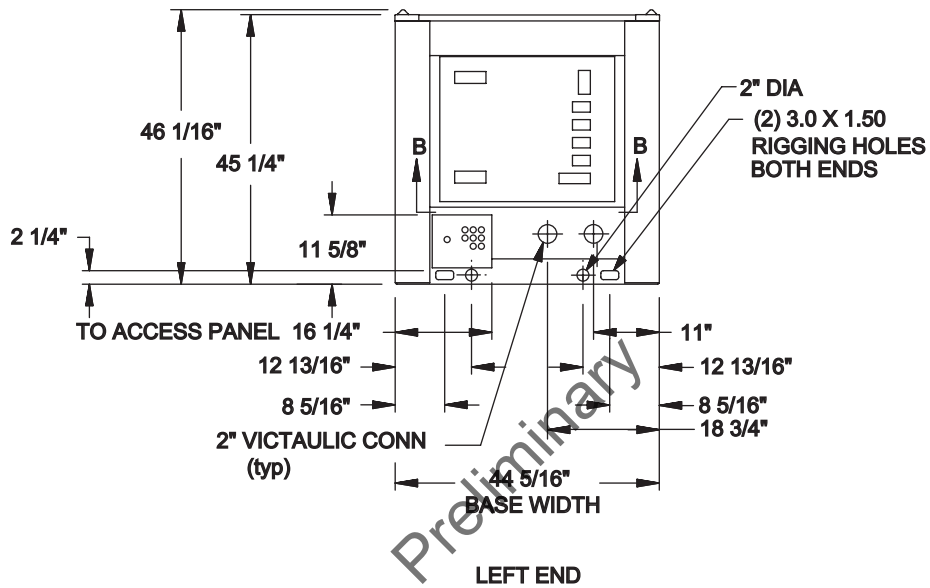
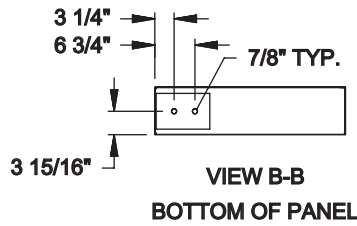

POWER: SINGLE POINT SUPPLY WITH TERMINAL BLOCK

NOTE:

Placement on a level surface of free of obstructions (including snow, for winter operation) or air circulation ensures rated performance, reliable operation, and ease of maintenance. Site restrictions may compromise minimum clearances indicated below, resulting in unpredictable airflow patterns and possible diminished performance. YORK's unit controls will optimize operation without nuisance high-pressure safety cutouts; however, the system designer must consider potential performance degradation. Recommended minimum clearances: front to wall – 6"; rear to wall – 6"; cooler end to wall – 4'0"; coil end to wall - 6"; top – no obstructions allowed; distance between adjacent units – 10'. No more than one adjacent wall may be higher than the unit. 1" nominal deflection isolators (not shown) will increase overall unit height by 6".

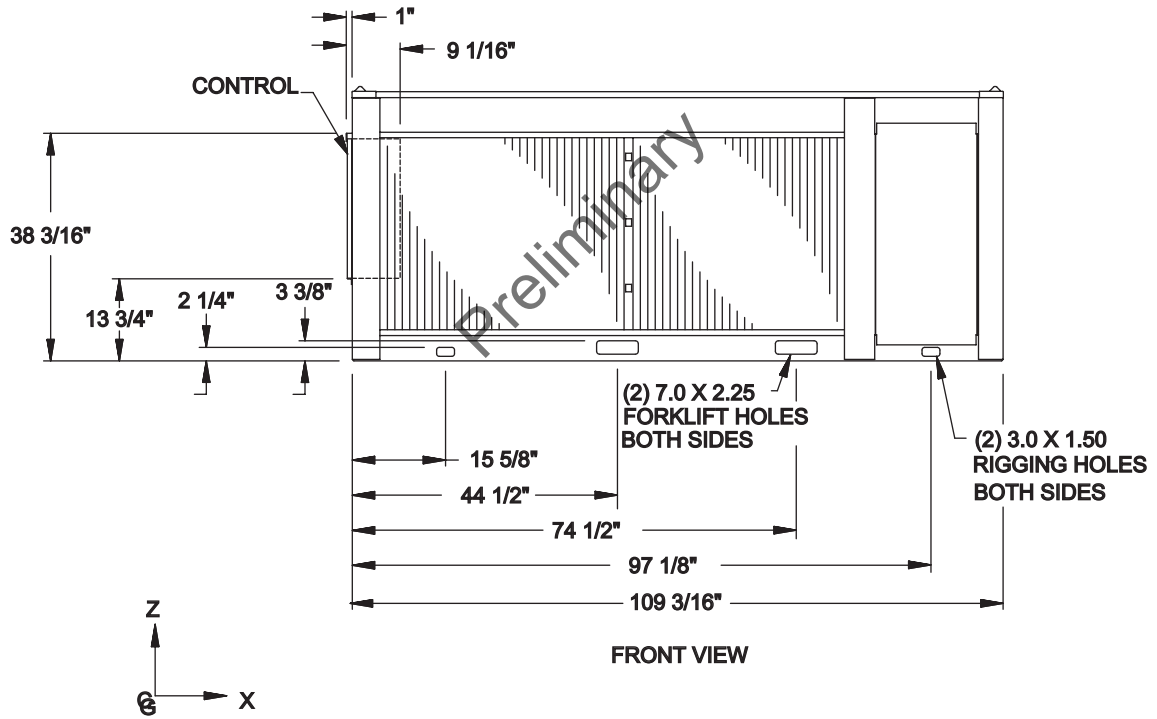
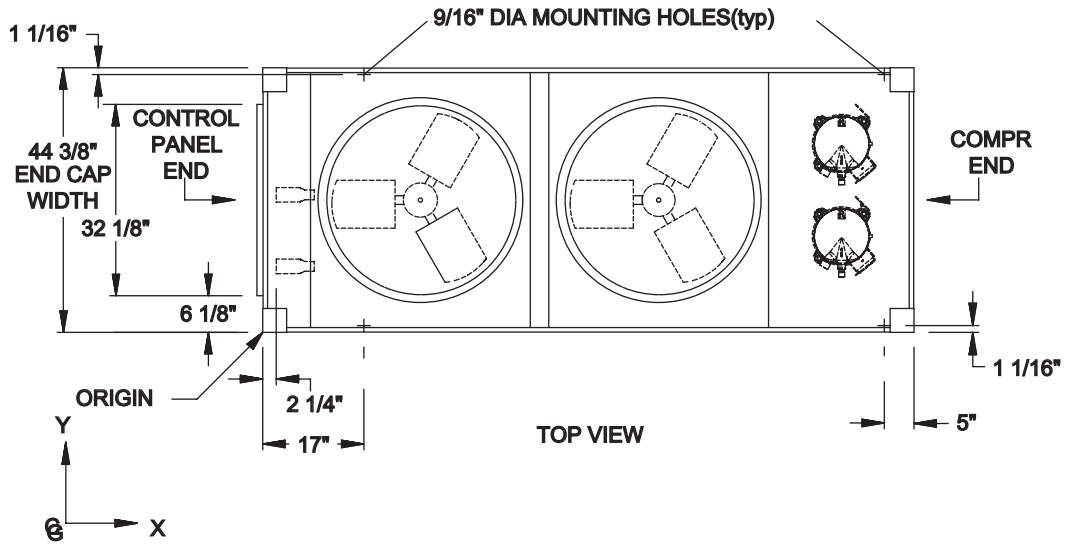

Dimensions - YCAL0025 (English)

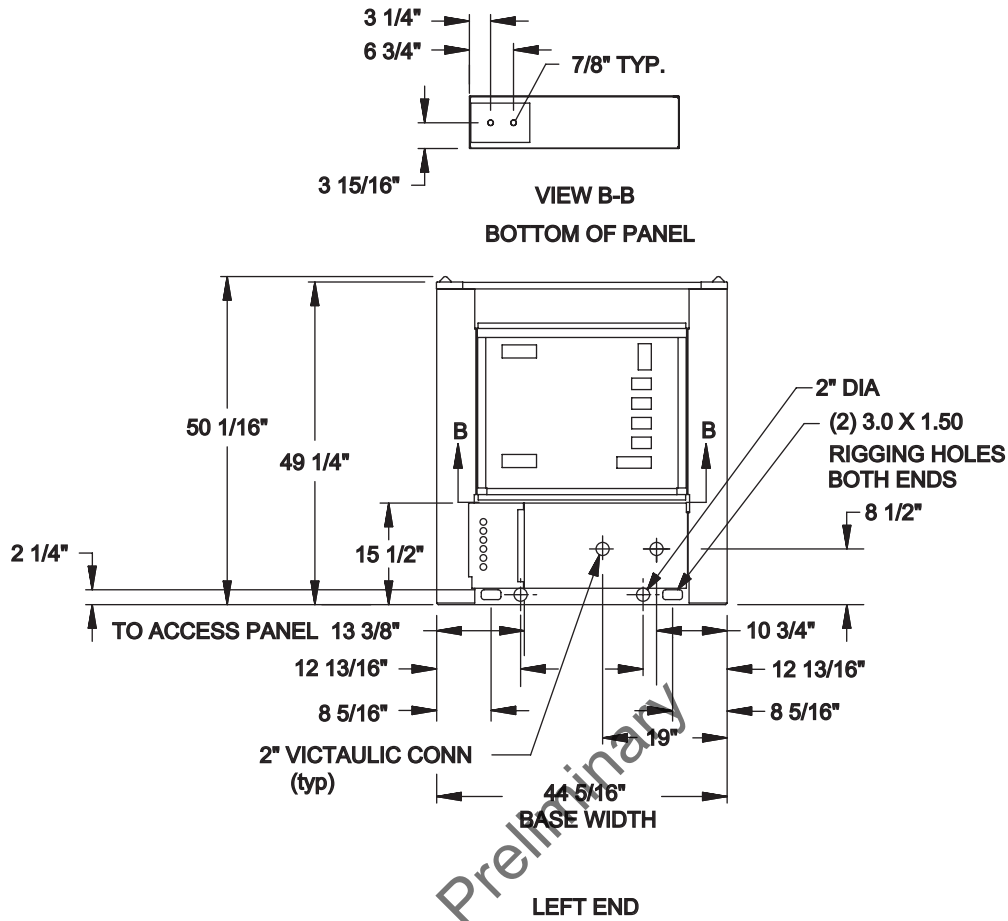

NOTE:

Placement on a level surface of free of obstructions (including snow, for winter operation) or air circulation ensures rated performance, reliable operation, and ease of maintenance. Site restrictions may compromise minimum clearances indicated below, resulting in unpredictable airflow patterns and possible diminished performance. YORK's unit controls will optimize operation without nuisance high-pressure safety cutouts; however, the system designer must consider potential performance degradation. Recommended minimum clearances: front to wall – 6"; rear to wall – 6"; cooler end to wall – 4'0"; coil end to wall - 6"; top – no obstructions allowed; distance between adjacent units – 10'. No more than one adjacent wall may be higher than the unit. 1" nominal deflection isolators (not shown) will increase overall unit height by 6".

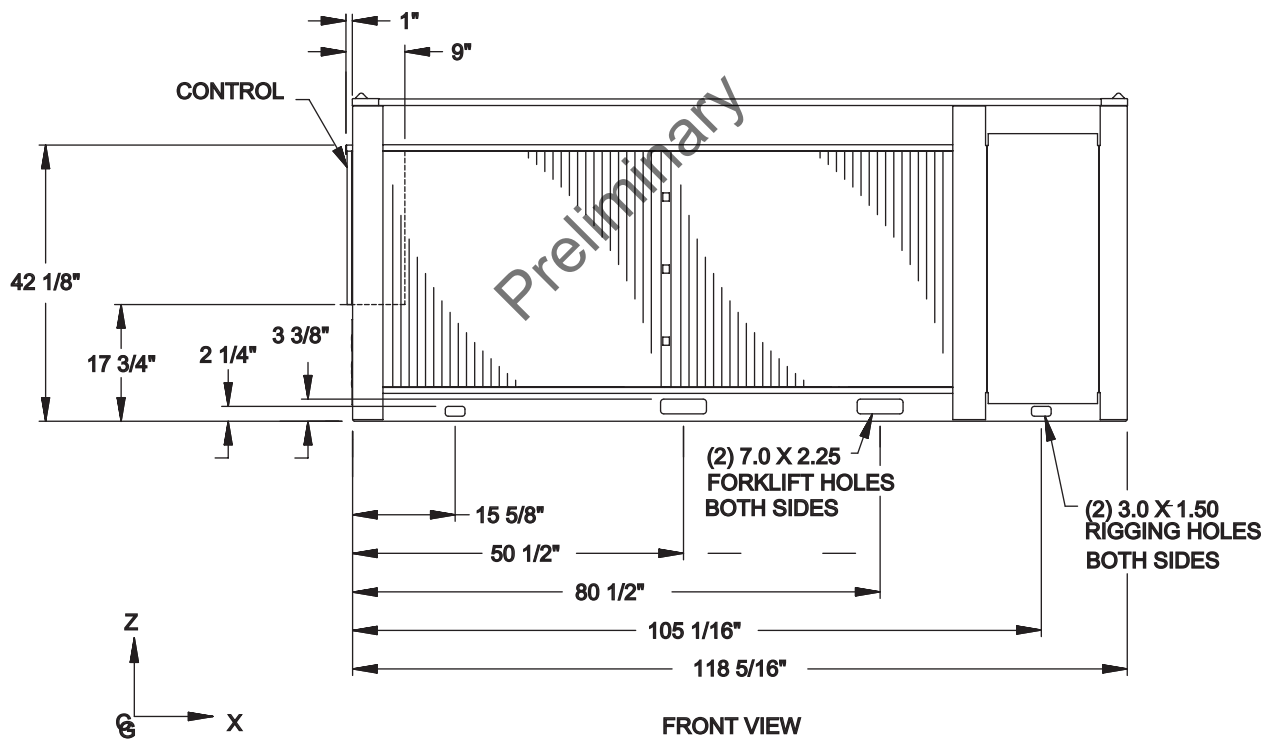
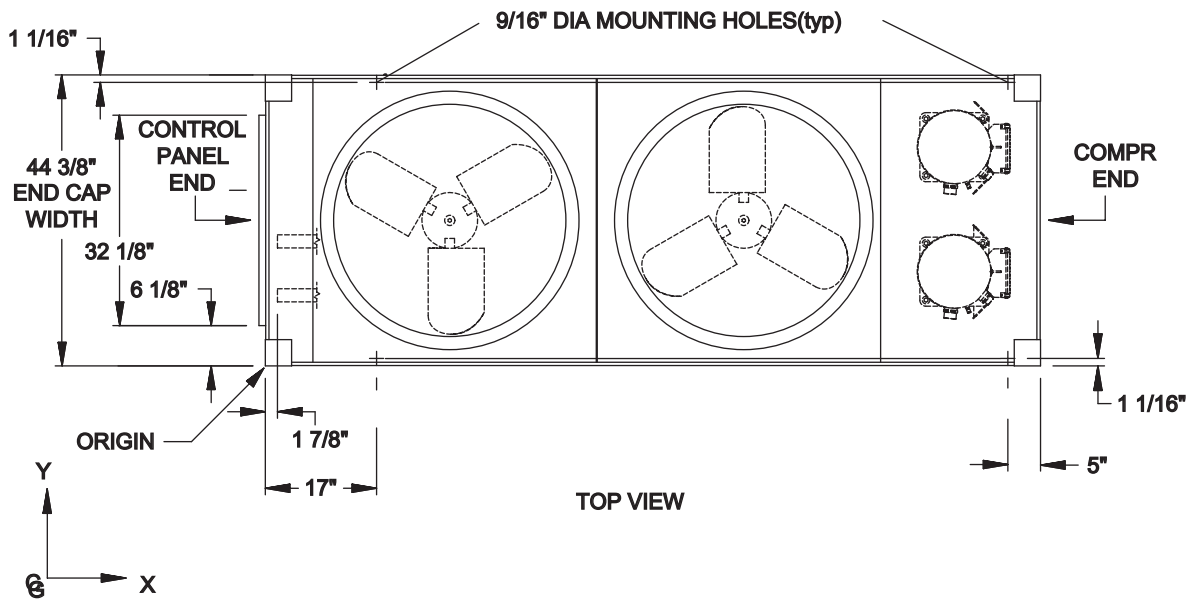

Dimensions - YCAL0027 (English)

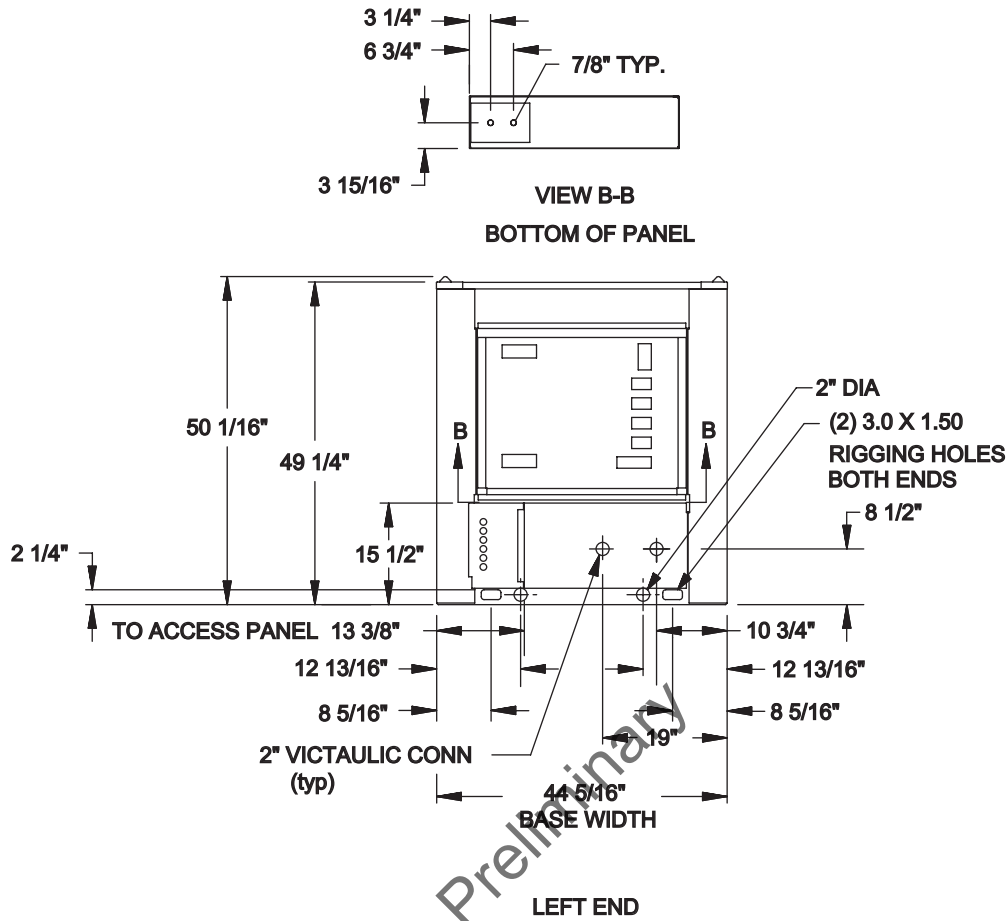

NOTE:

Placement on a level surface of free of obstructions (including snow, for winter operation) or air circulation ensures rated performance, reliable operation, and ease of maintenance. Site restrictions may compromise minimum clearances indicated below, resulting in unpredictable airflow patterns and possible diminished performance. YORK's unit controls will optimize operation without nuisance high-pressure safety cutouts; however, the system designer must consider potential performance degradation. Recommended minimum clearances: front to wall – 6"; rear to wall – 6"; cooler end to wall – 4'0"; coil end to wall - 6"; top – no obstructions allowed; distance between adjacent units – 10'. No more than one adjacent wall may be higher than the unit. 1" nominal deflection isolators (not shown) will increase overall unit height by 6".

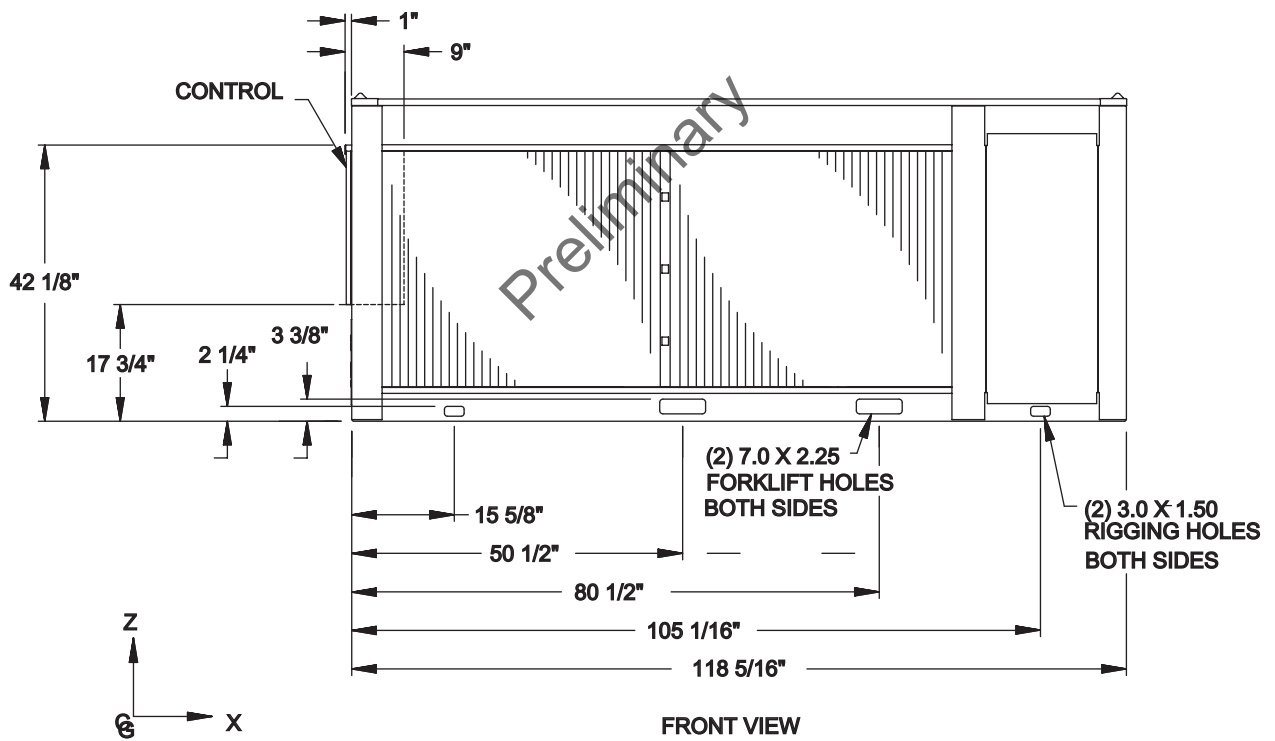
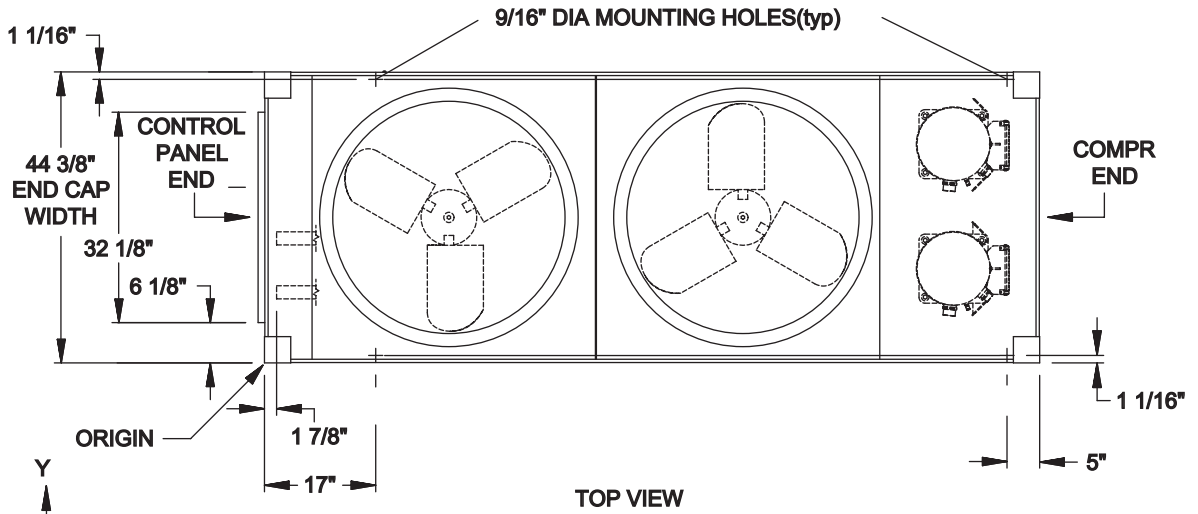

Dimensions - YCAL0032 (English)

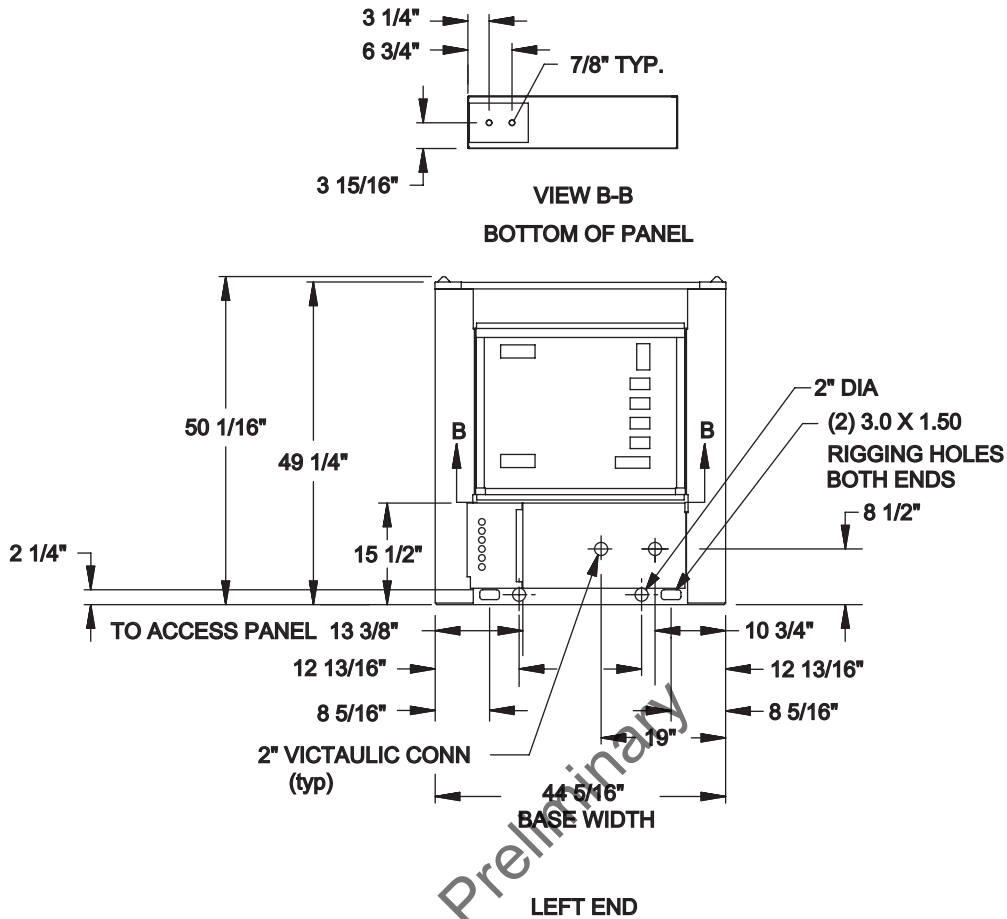

NOTE:

Placement on a level surface of free of obstructions (including snow, for winter operation) or air circulation ensures rated performance, reliable operation, and ease of maintenance. Site restrictions may compromise minimum clearances indicated below, resulting in unpredictable airflow patterns and possible diminished performance. YORK's unit controls will optimize operation without nuisance high-pressure safety cutouts; however, the system designer must consider potential performance degradation. Recommended minimum clearances: front to wall - 6"; rear to wall - 6"; cooler end to wall - 4'0"; coil end to wall - 6"; top - no obstructions allowed; distance between adjacent units - 10'. No more than one adjacent wall may be higher than the unit. 1" nominal deflection isolators (not shown) will increase overall unit height by 6".

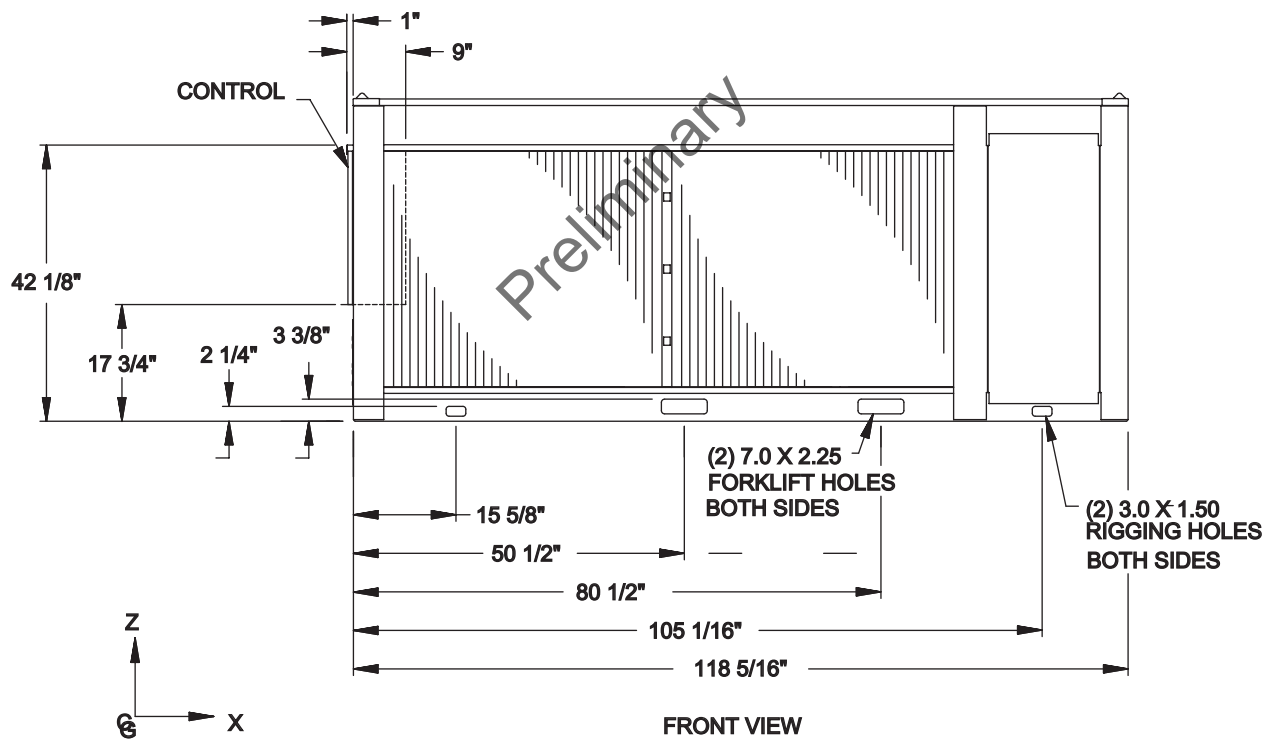
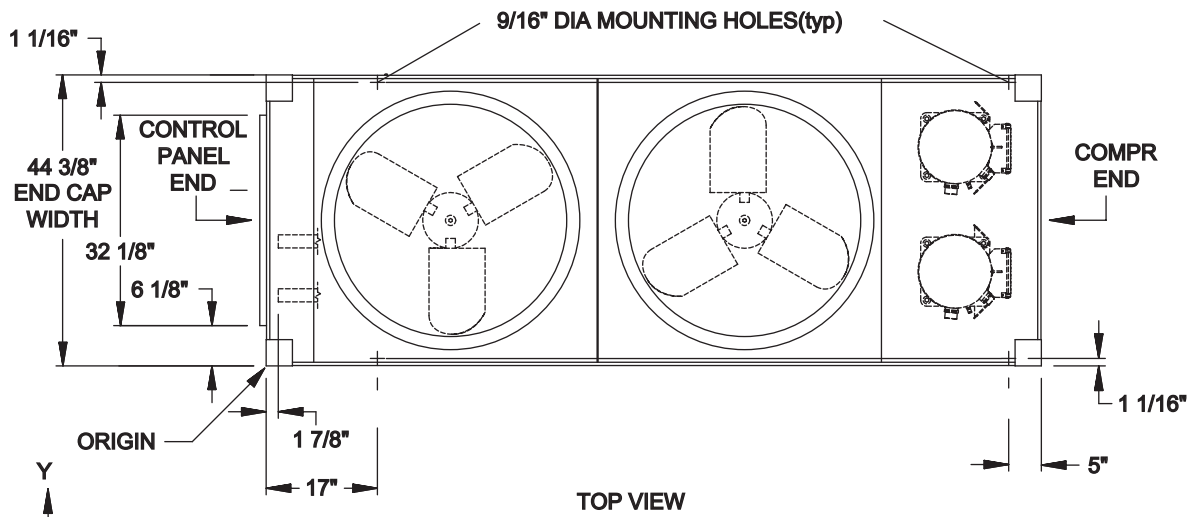

Dimensions - YCAL0012 (SI)

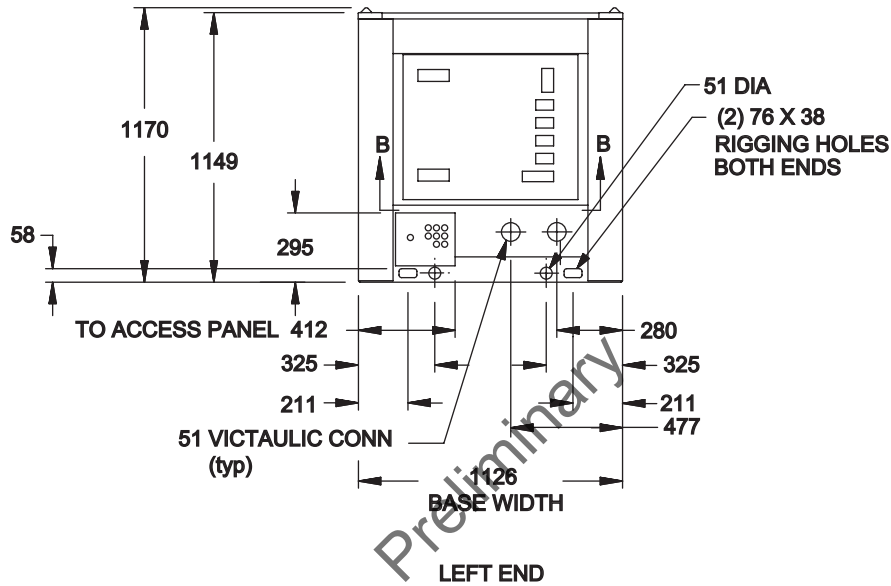
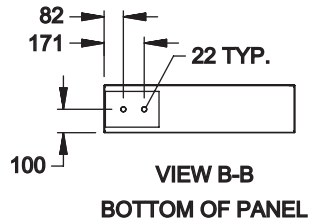

POWER: SINGLE POINT SUPPLY WITH TERMINAL BLOCK

NOTE:

Placement on a level surface of free of obstructions (including snow, for winter operation) or air circulation ensures rated performance, reliable operation, and ease of maintenance. Site restrictions may compromise minimum clearances indicated below, resulting in unpredictable airflow patterns and possible diminished performance. YORK's unit controls will optimize operation without nuisance high-pressure safety cutouts; however, the system designer must consider potential performance degradation. Recommended minimum clearances: front to wall - 6"; rear to wall - 6"; cooler end to wall - 4'0"; coil end to wall - 6"; top - no obstructions allowed; distance between adjacent units - 10'. No more than one adjacent wall may be higher than the unit. 1" nominal deflection isolators (not shown) will increase overall unit height by 6".

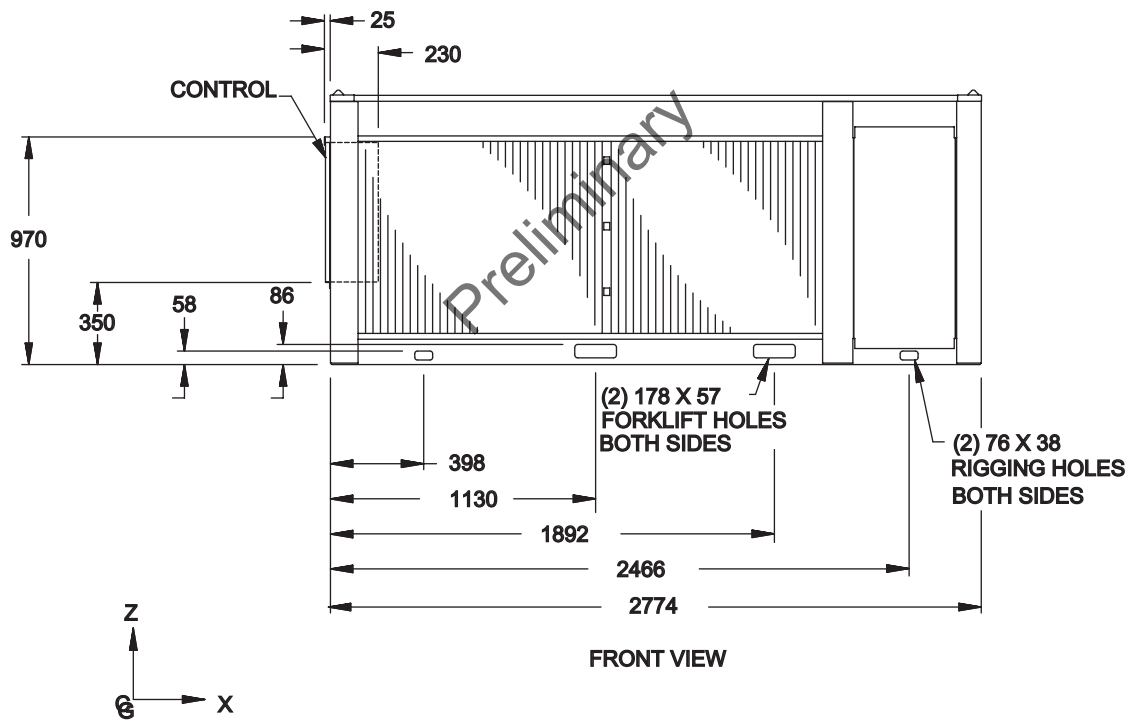
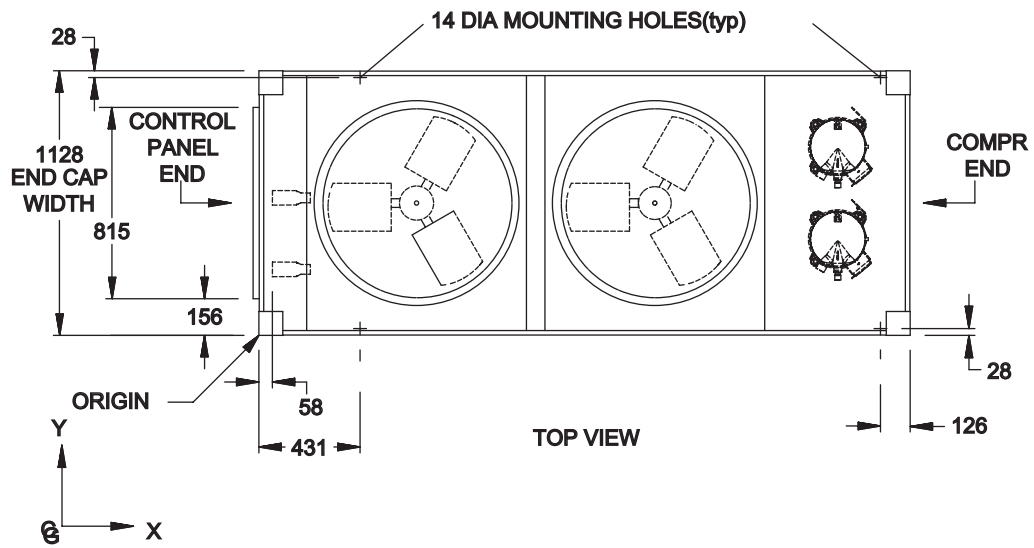

Dimensions - YCAL0018 (SI)

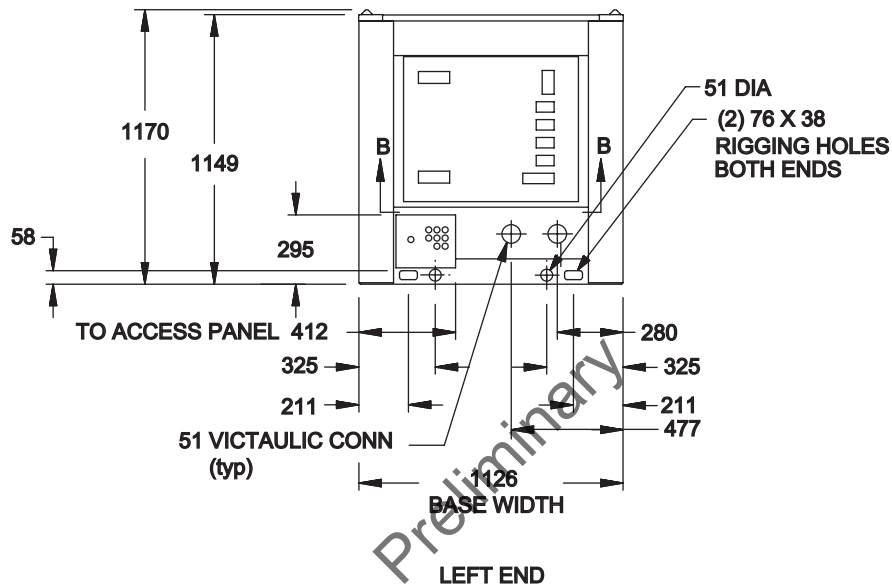
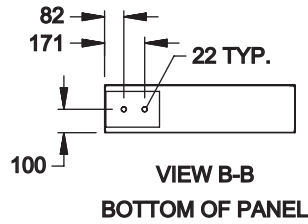

POWER: SINGLE POINT SUPPLY WITH TERMINAL BLOCK

NOTE:

Placement on a level surface of free of obstructions (including snow, for winter operation) or air circulation ensures rated performance, reliable operation, and ease of maintenance. Site restrictions may compromise minimum clearances indicated below, resulting in unpredictable airflow patterns and possible diminished performance. YORK's unit controls will optimize operation without nuisance high-pressure safety cutouts; however, the system designer must consider potential performance degradation. Recommended minimum clearances: front to wall - 6"; rear to wall - 6"; cooler end to wall - 4'0"; coil end to wall - 6"; top - no obstructions allowed; distance between adjacent units - 10'. No more than one adjacent wall may be higher than the unit. 1" nominal deflection isolators (not shown) will increase overall unit height by 6".

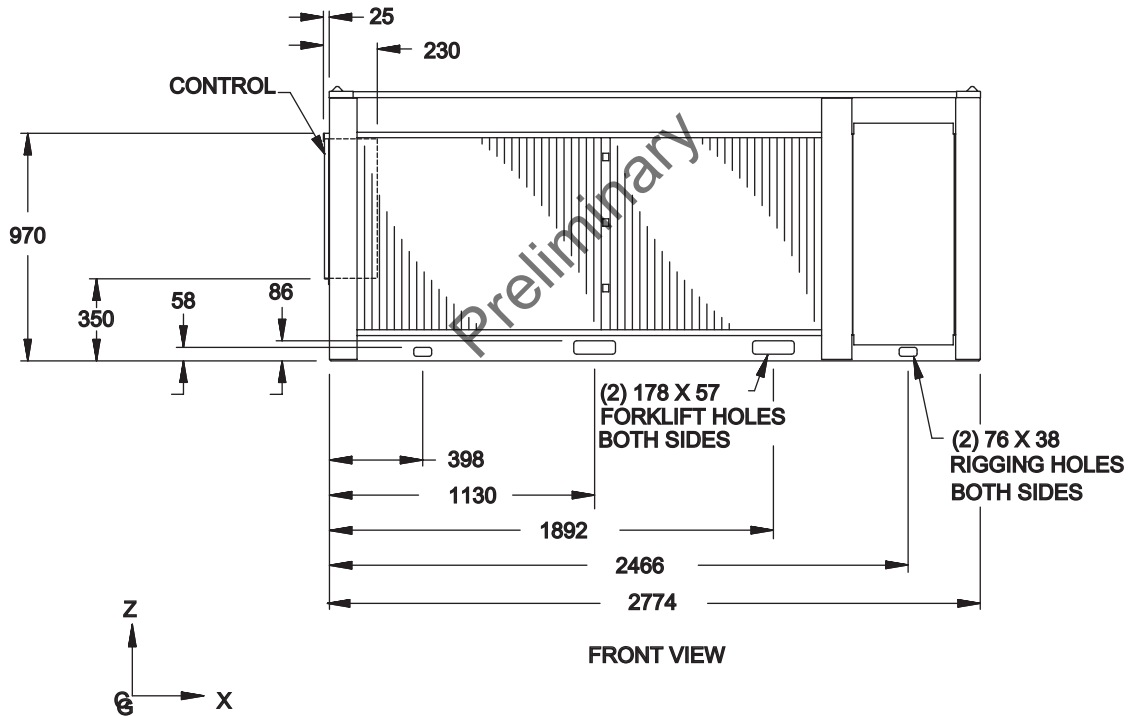
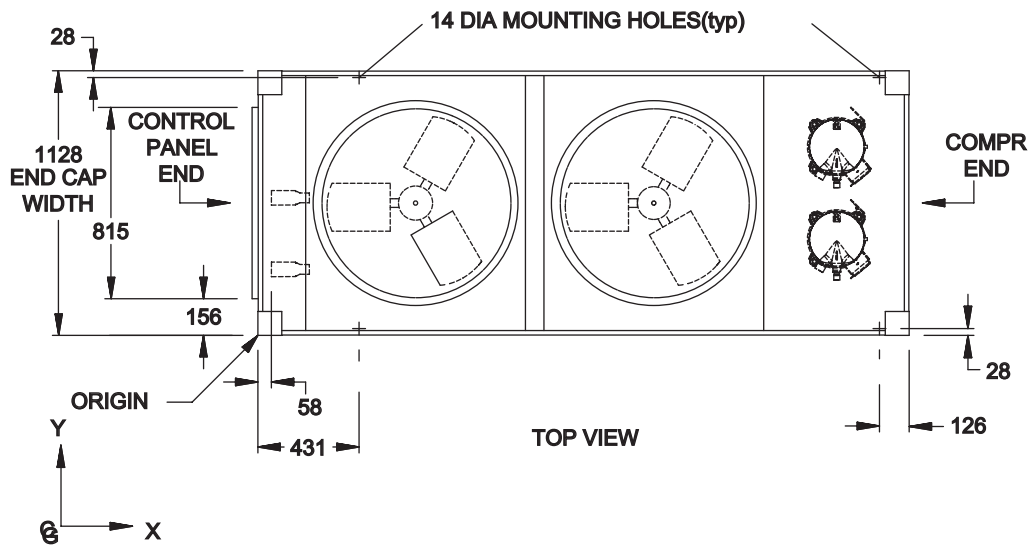

Dimensions - YCAL0021 (SI)

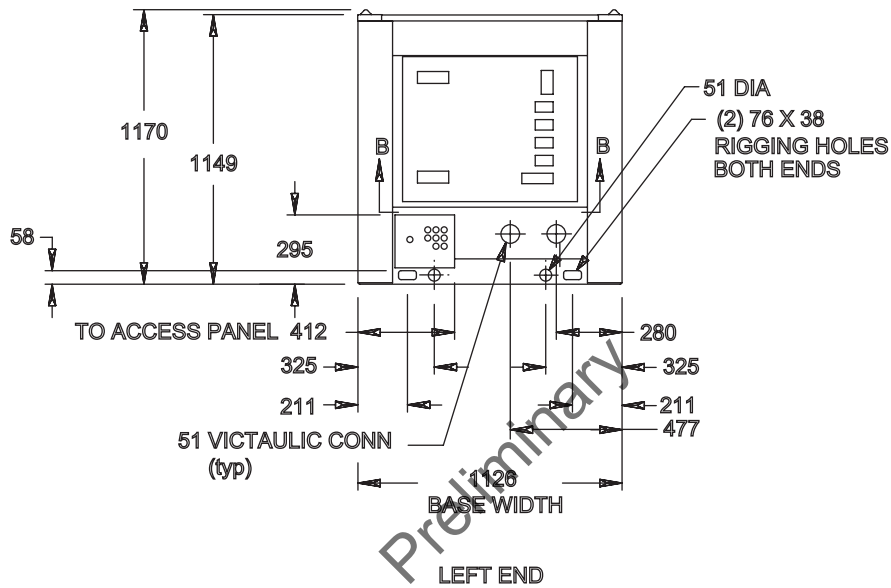
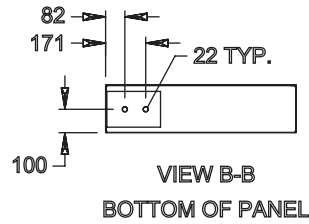

POWER: SINGLE POINT SUPPLY WITH TERMINAL BLOCK

NOTE:

Placement on a level surface of free of obstructions (including snow, for winter operation) or air circulation ensures rated performance, reliable operation, and ease of maintenance. Site restrictions may compromise minimum clearances indicated below, resulting in unpredictable airflow patterns and possible diminished performance. YORK's unit controls will optimize operation without nuisance high-pressure safety cutouts; however, the system designer must consider potential performance degradation. Recommended minimum clearances: front to wall – 6'; rear to wall – 6'; cooler end to wall – 4'0"; coil end to wall - 6'; top – no obstructions allowed; distance between adjacent units – 10'. No more than one adjacent wall may be higher than the unit. 1" nominal deflection isolators (not shown) will increase overall unit height by 6".

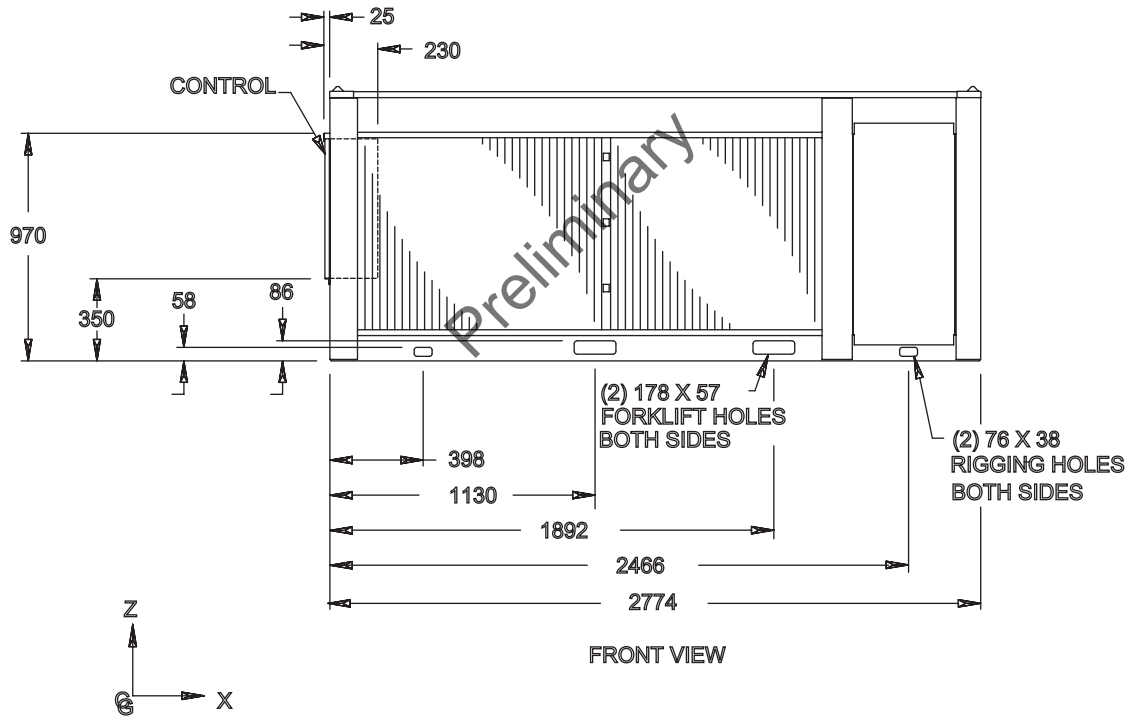
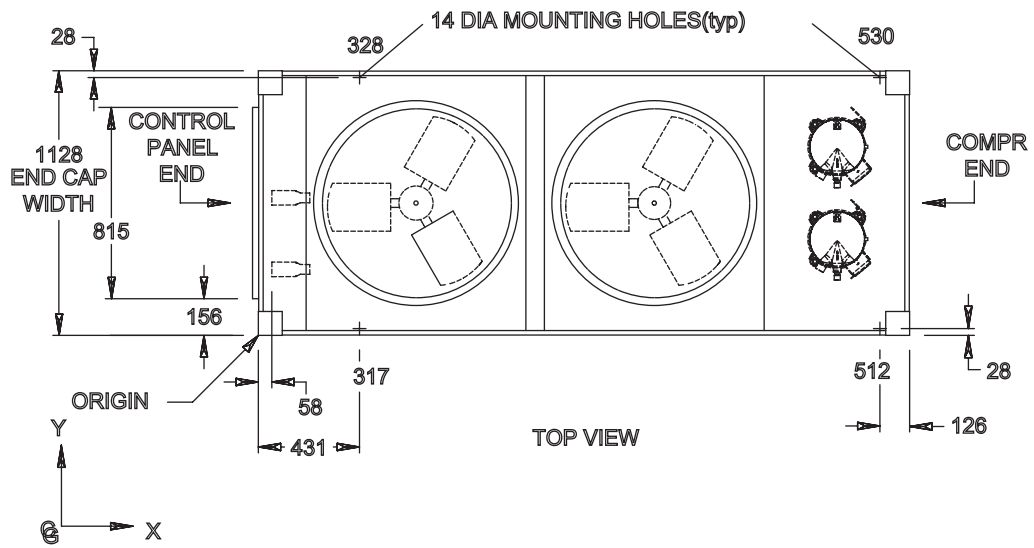

Dimensions - YCAL0025 (SI)

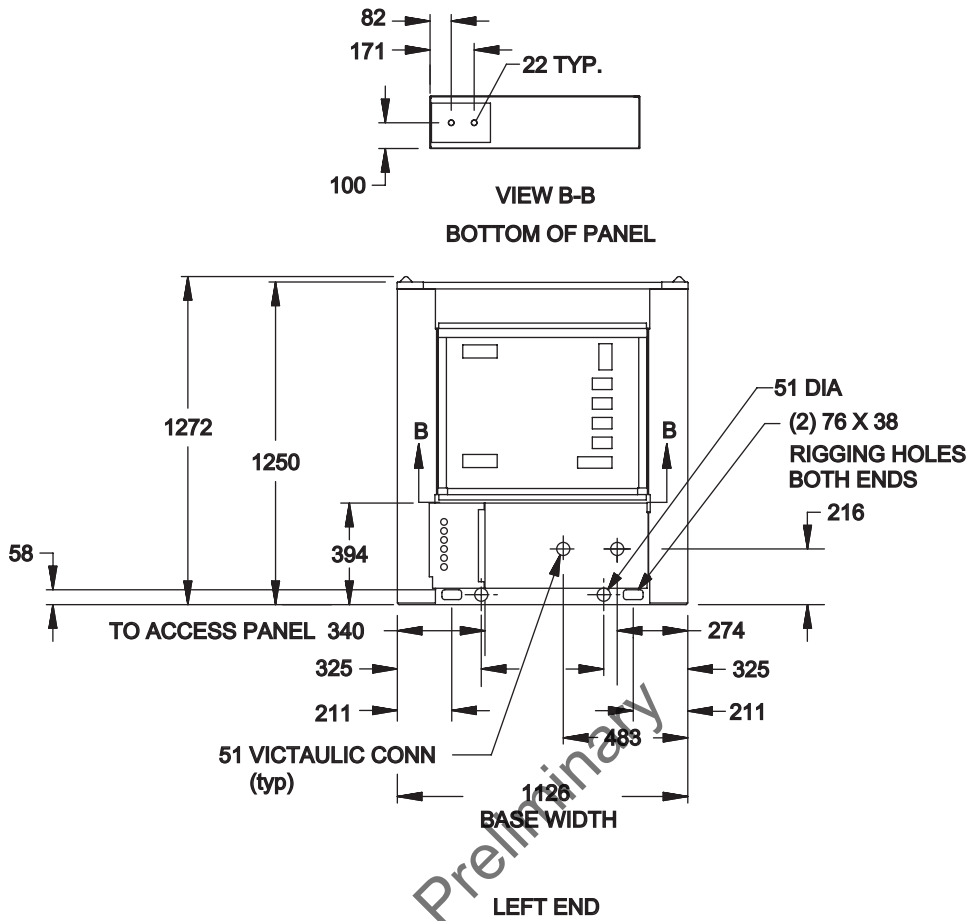

NOTE:

Placement on a level surface of free of obstructions (including snow, for winter operation) or air circulation ensures rated performance, reliable operation, and ease of maintenance. Site restrictions may compromise minimum clearances indicated below, resulting in unpredictable airflow patterns and possible diminished performance. YORK's unit controls will optimize operation without nuisance high-pressure safety cutouts; however, the system designer must consider potential performance degradation. Recommended minimum clearances: front to wall - 6'; rear to wall - 6'; cooler end to wall - 4'0"; coil end to wall - 6'; top - no obstructions allowed; distance between adjacent units - 10'. No more than one adjacent wall may be higher than the unit. 1" nominal deflection isolators (not shown) will increase overall unit height by 6".

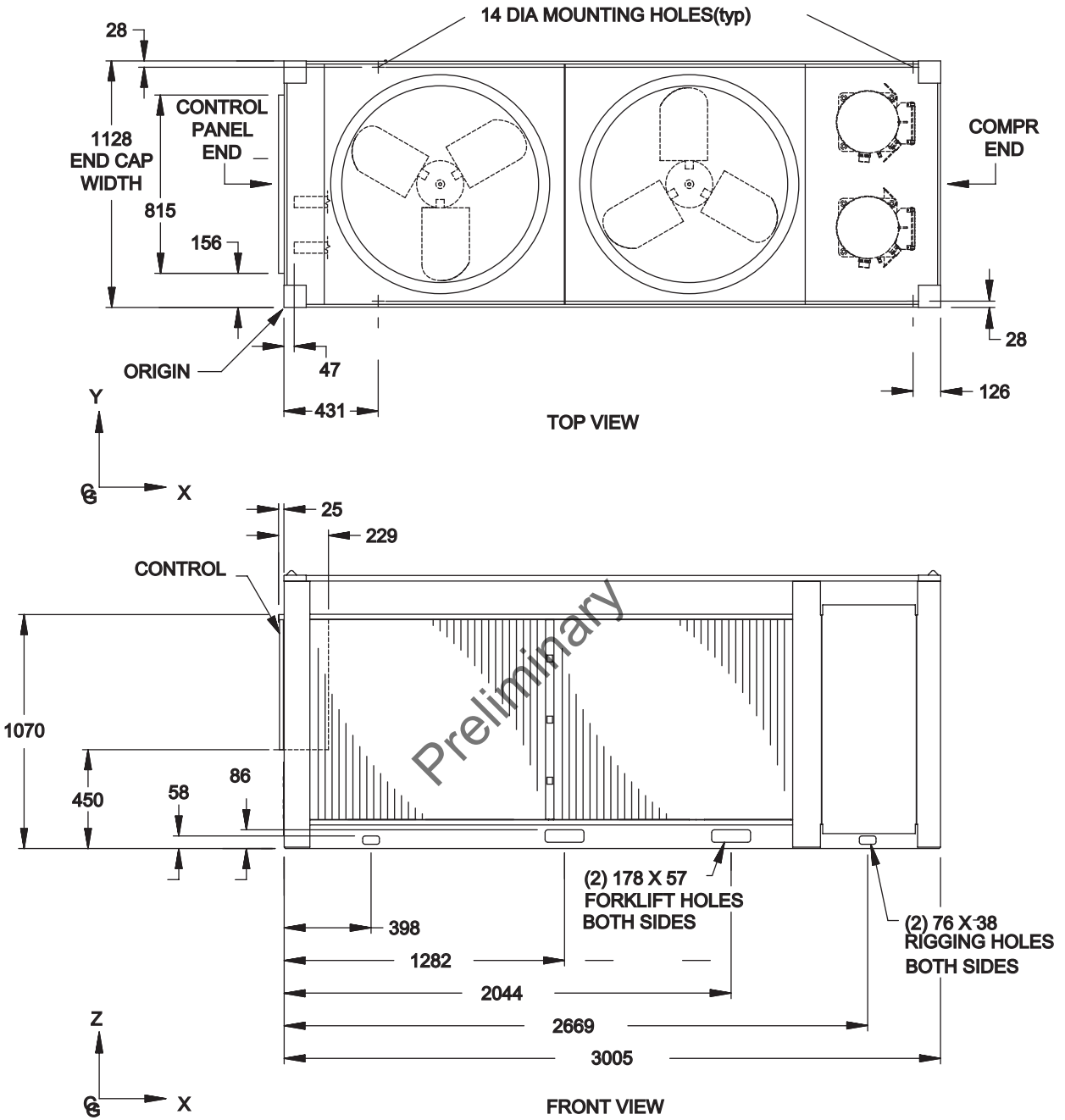

Dimensions - YCAL0027 (SI)

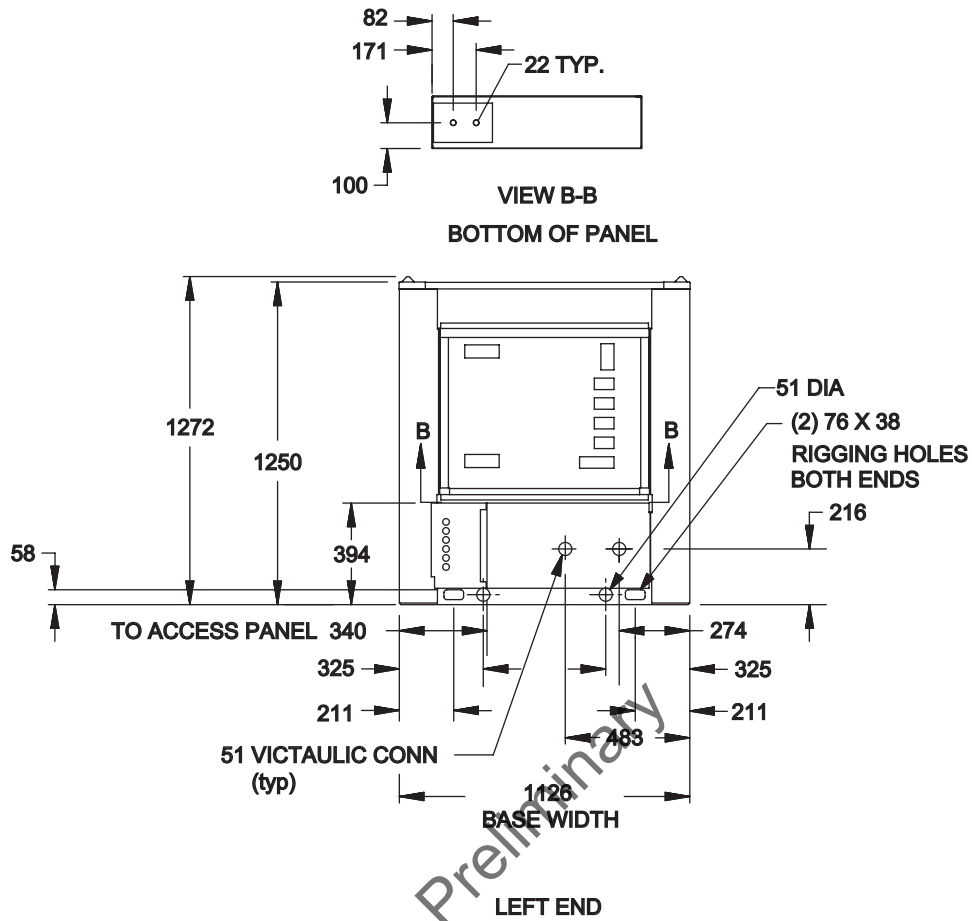

NOTE:

Placement on a level surface of free of obstructions (including snow, for winter operation) or air circulation ensures rated performance, reliable operation, and ease of maintenance. Site restrictions may compromise minimum clearances indicated below, resulting in unpredictable airflow patterns and possible diminished performance. YORK's unit controls will optimize operation without nuisance high-pressure safety cutouts; however, the system designer must consider potential performance degradation. Recommended minimum clearances: front to wall - 6'; rear to wall - 6'; cooler end to wall - 4'0"; coil end to wall - 6'; top - no obstructions allowed; distance between adjacent units - 10'. No more than one adjacent wall may be higher than the unit. 1" nominal deflection isolators (not shown) will increase overall unit height by 6".

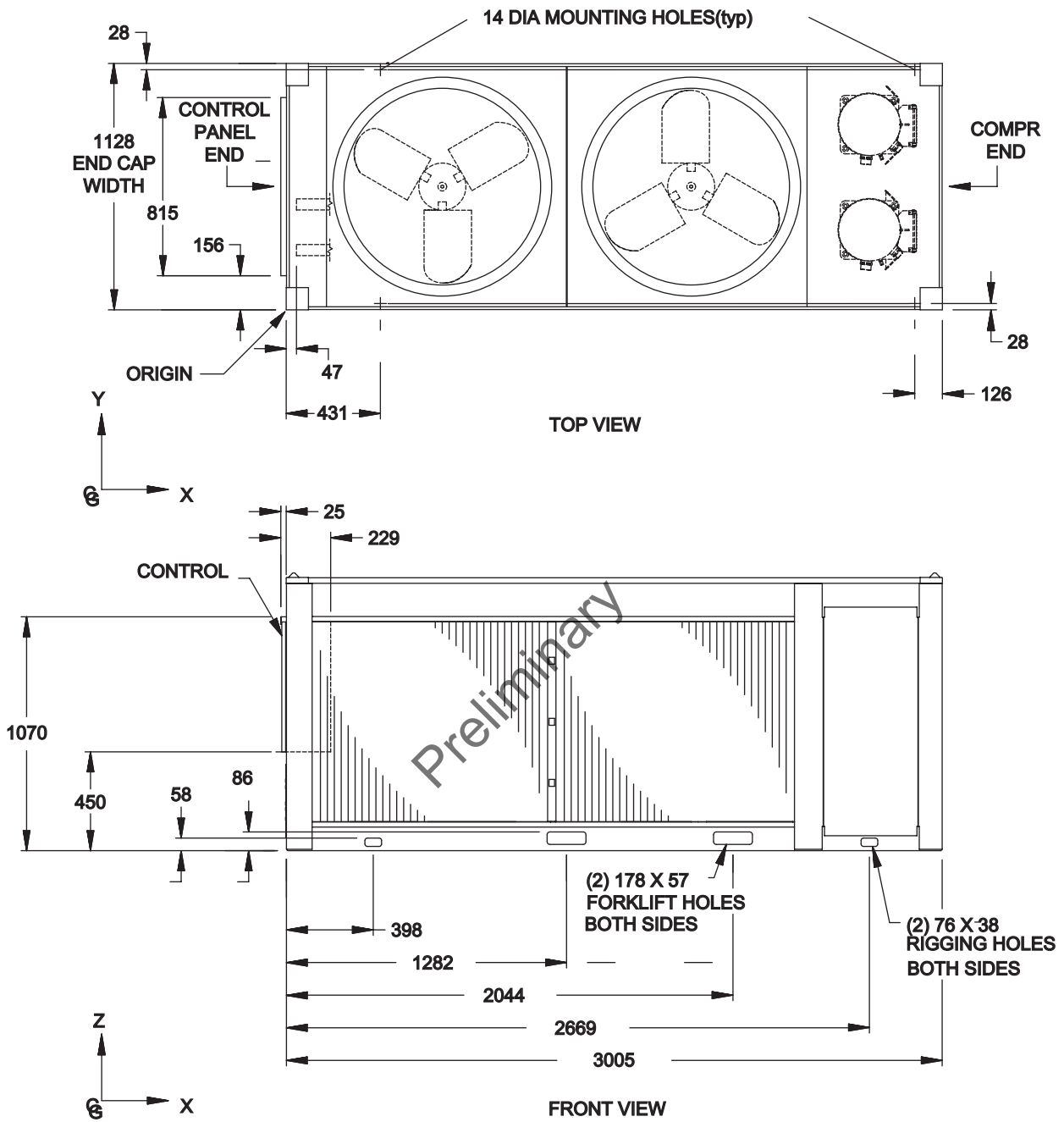

Dimensions - YCAL0032 (SI)

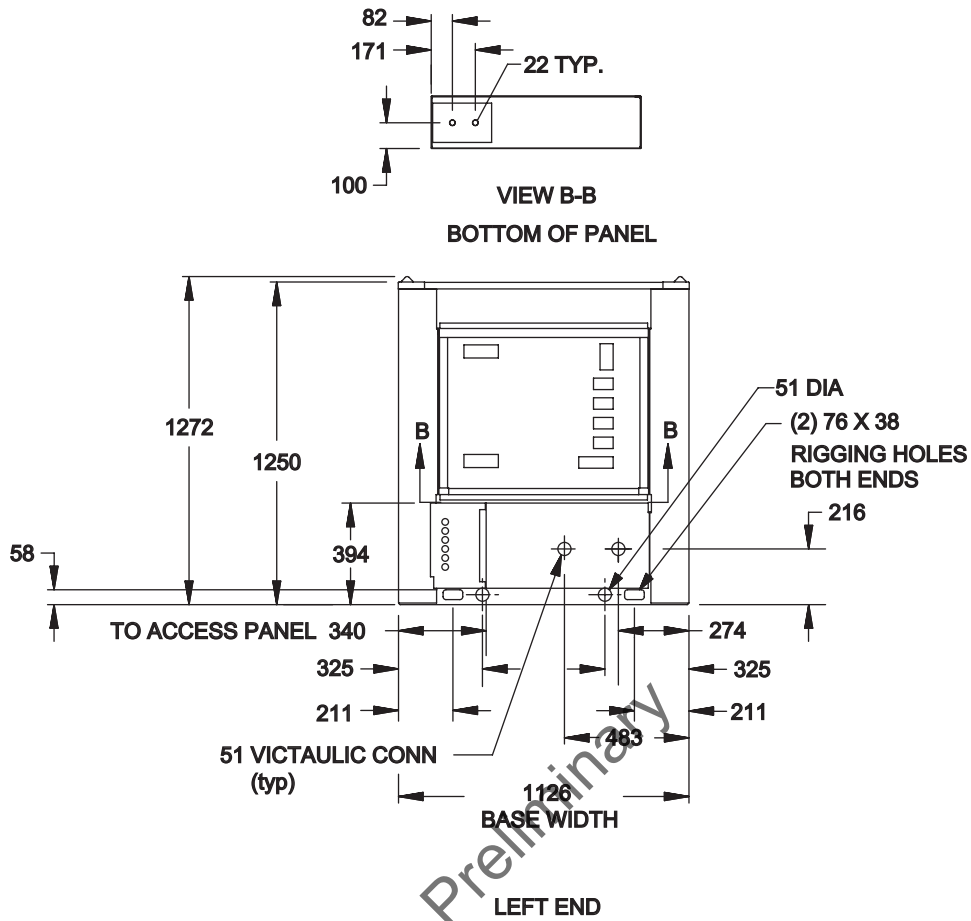

NOTE:

Placement on a level surface of free of obstructions (including snow, for winter operation) or air circulation ensures rated performance, reliable operation, and ease of maintenance. Site restrictions may compromise minimum clearances indicated below, resulting in unpredictable airflow patterns and possible diminished performance. YORK's unit controls will optimize operation without nuisance high-pressure safety cutouts; however, the system designer must consider potential performance degradation. Recommended minimum clearances: front to wall – 6'; rear to wall – 6'; cooler end to wall – 4'0"; coil end to wall - 6'; top – no obstructions allowed; distance between adjacent units – 10'. No more than one adjacent wall may be higher than the unit. 1" nominal deflection isolators (not shown) will increase overall unit height by 6".

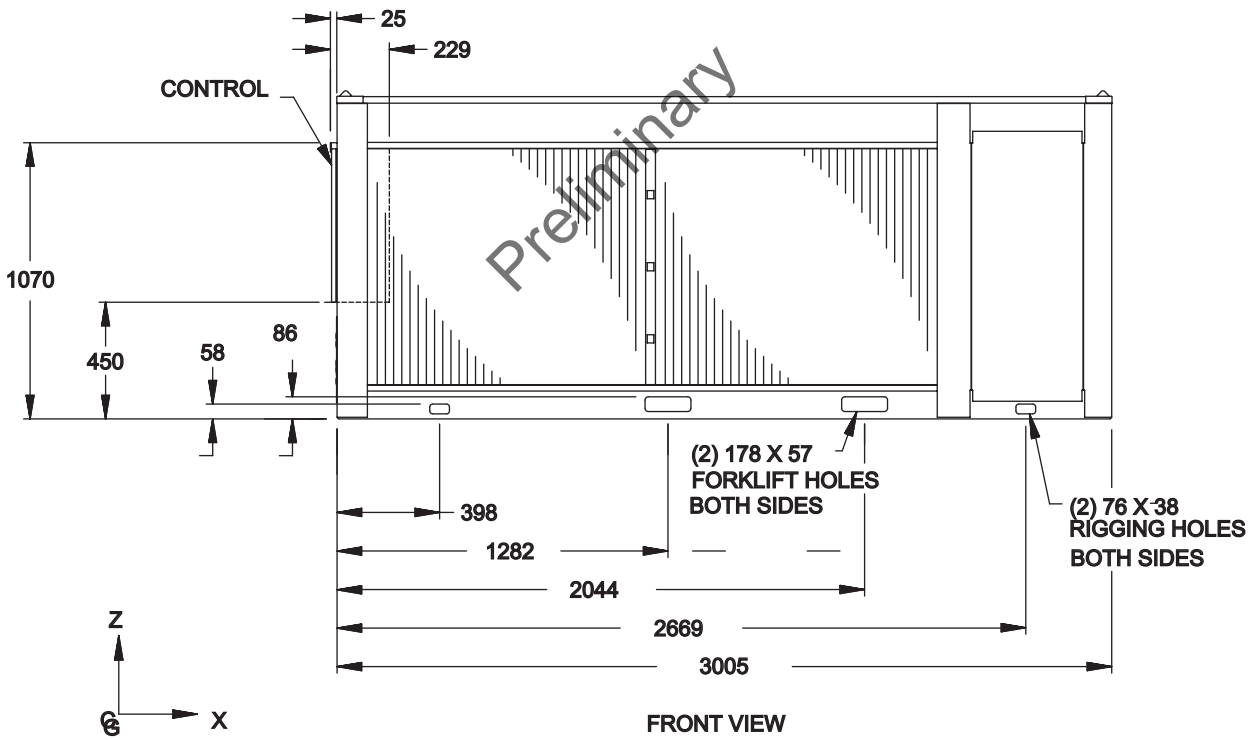
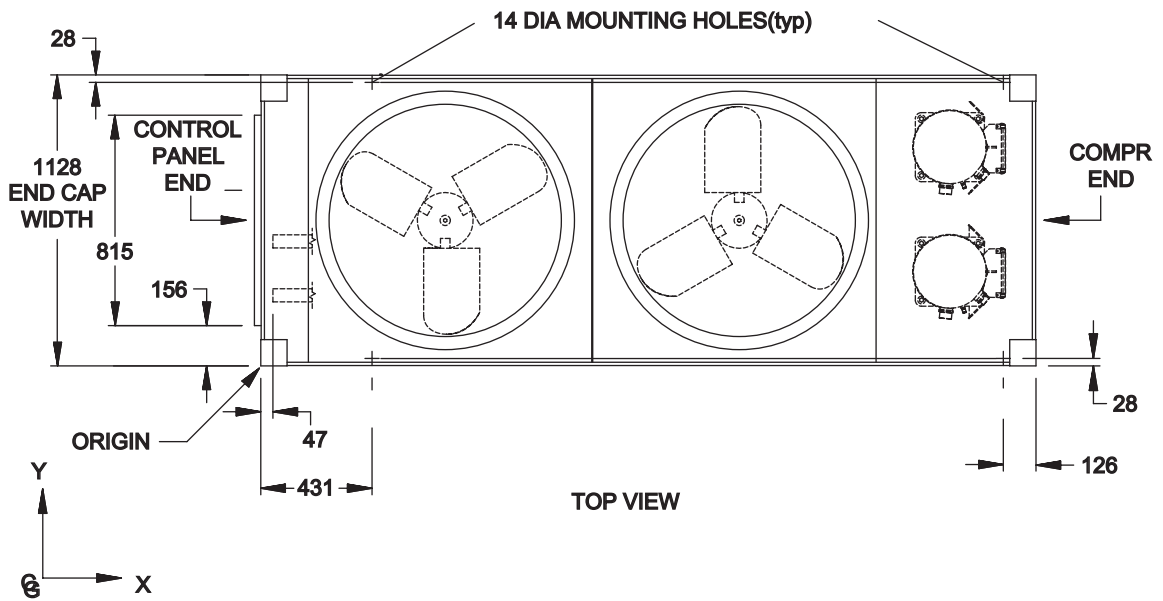

Dimensions - YCAL0041 (English)

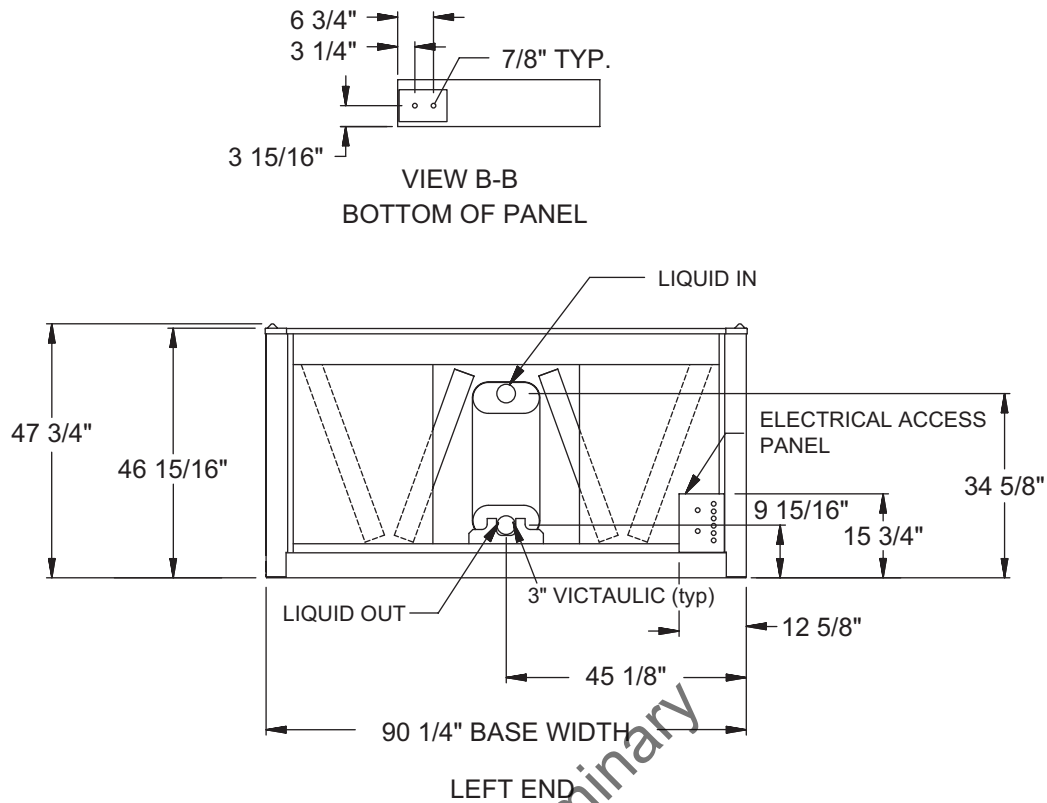

Preliminary

Aluminum		
YCAL	Center of Gravity (in.)	
	X	Y
0041	59.6	43.6

Copper		
YCAL	Center of Gravity (in.)	
	X	Y
0041	63.6	43.7

NOTE:

Placement on a level surface free of obstructions (including snow, for winter operation) or air circulation ensures rated performance, reliable operation, and ease of maintenance. Site restrictions may compromise minimum clearances indicated below, resulting in unpredictable airflow patterns and possible diminished performance. YORK's unit controls will optimize operation without nuisance high-pressure safety cutouts; however, the system designer must consider potential performance degradation. Recommended minimum clearances: front to wall - 6'; rear to wall - 6'; cooler end to wall - 4'0"; coil end to wall - 6'; top - no obstructions allowed; distance between adjacent units - 10'. No more than one adjacent wall may be higher than the unit. 1" nominal deflection isolators (not shown) will increase overall unit height by 6".

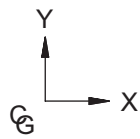
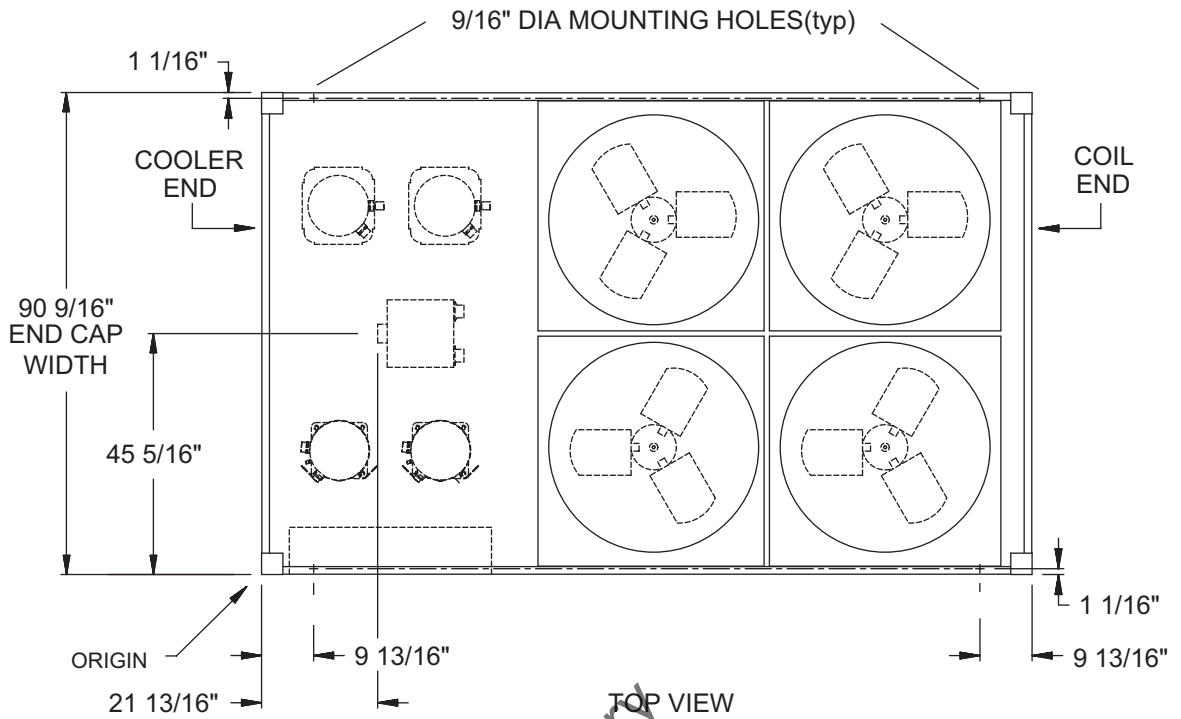

Preliminary

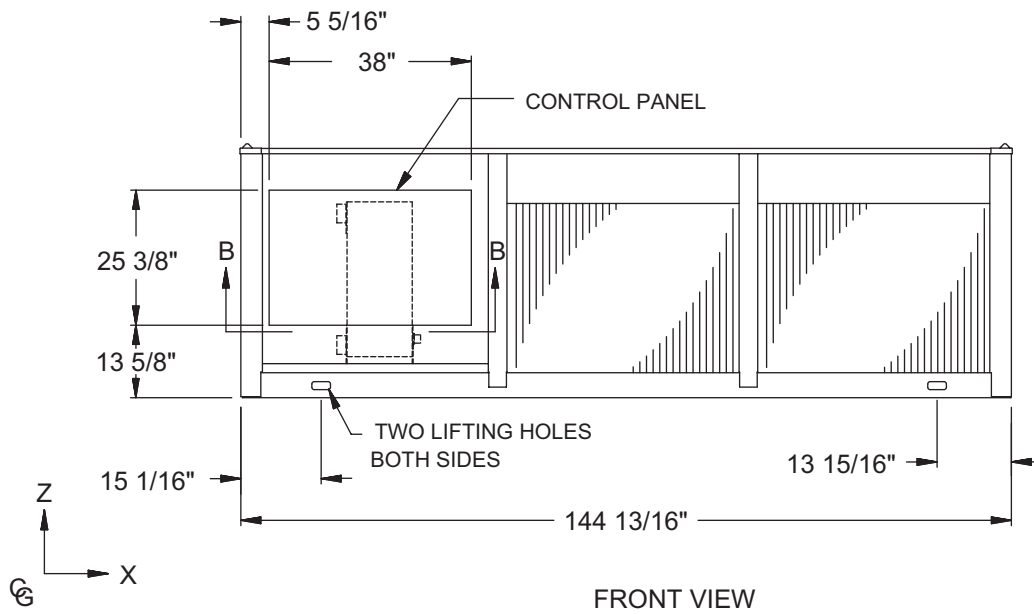

Dimensions - YCAL0045 (English)

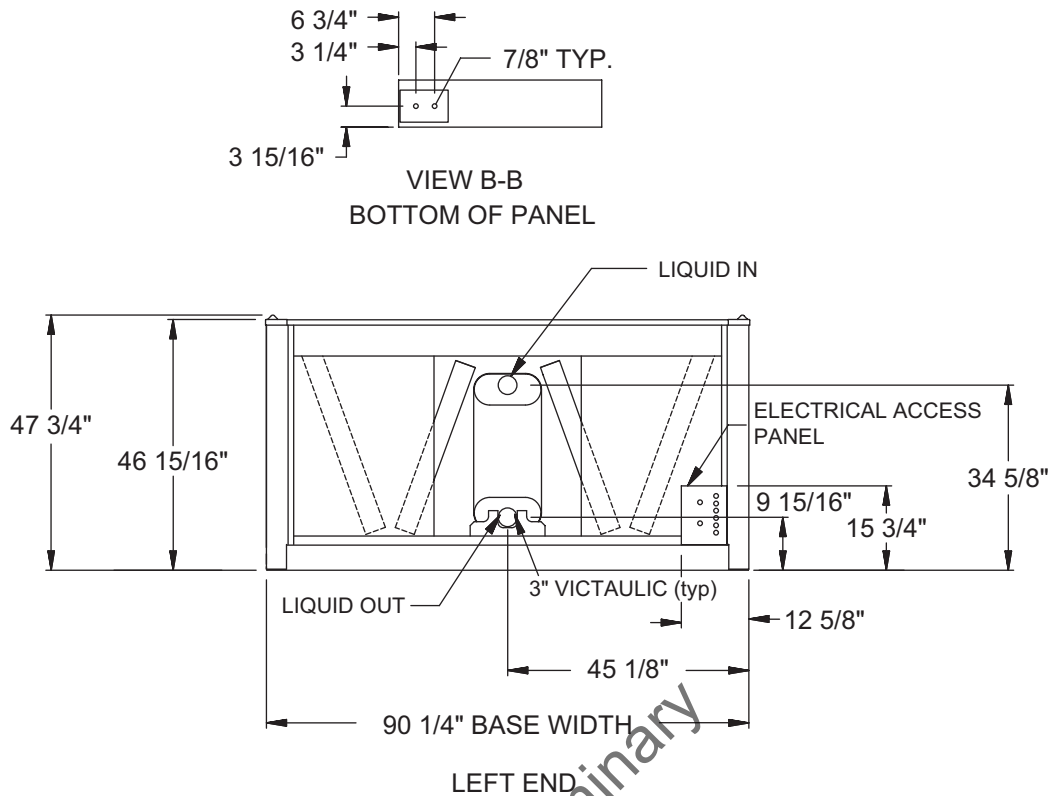

Preliminary

Aluminum		
YCAL	Center of Gravity (in.)	
	X	Y
0045	59.2	43.5

Copper		
YCAL	Center of Gravity (in.)	
	X	Y
0045	63.2	43.7

NOTE:

Placement on a level surface of free of obstructions (including snow, for winter operation) or air circulation ensures rated performance, reliable operation, and ease of maintenance. Site restrictions may compromise minimum clearances indicated below, resulting in unpredictable airflow patterns and possible diminished performance. YORK's unit controls will optimize operation without nuisance high-pressure safety cutouts; however, the system designer must consider potential performance degradation. Recommended minimum clearances: front to wall – 6'; rear to wall – 6'; cooler end to wall – 4'0"; coil end to wall - 6'; top – no obstructions allowed; distance between adjacent units – 10'. No more than one adjacent wall may be higher than the unit. 1" nominal deflection isolators (not shown) will increase overall unit height by 6".

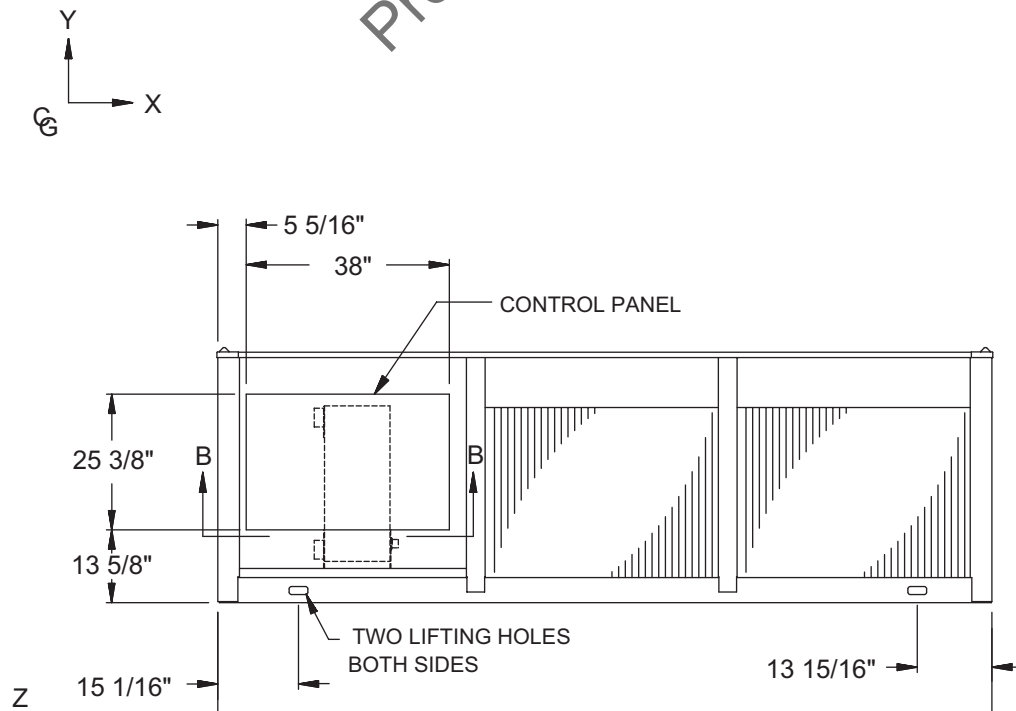
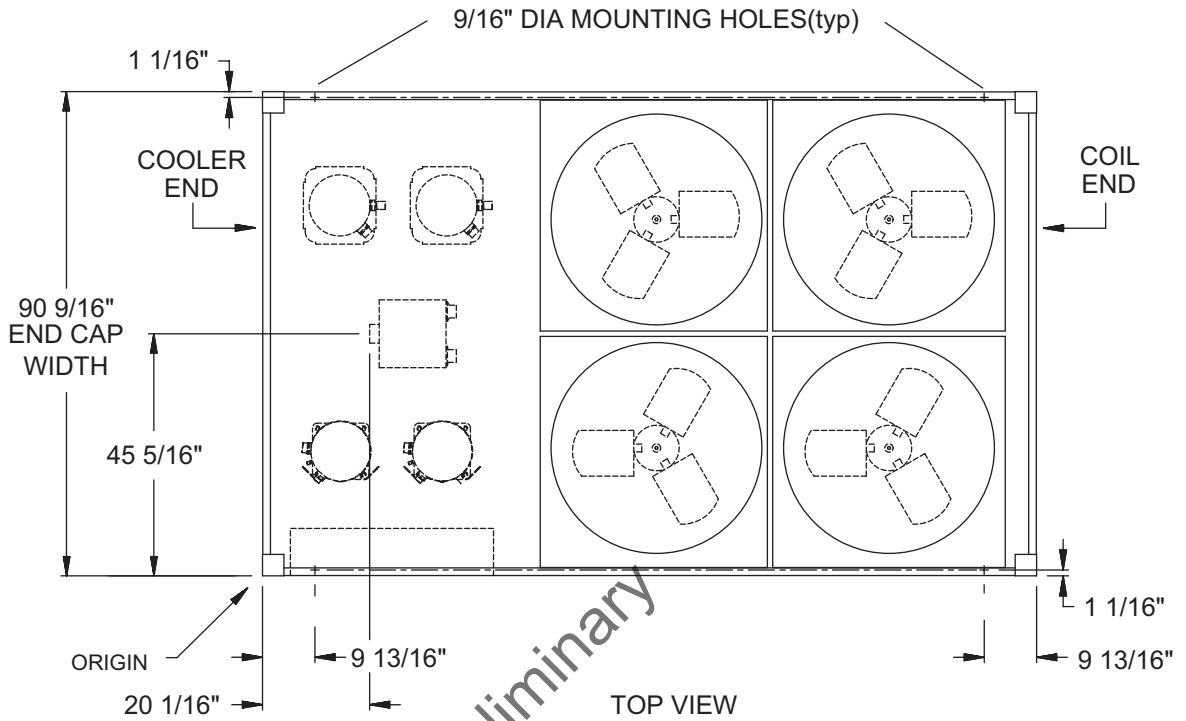

Dimensions - YCAL0051 (English)

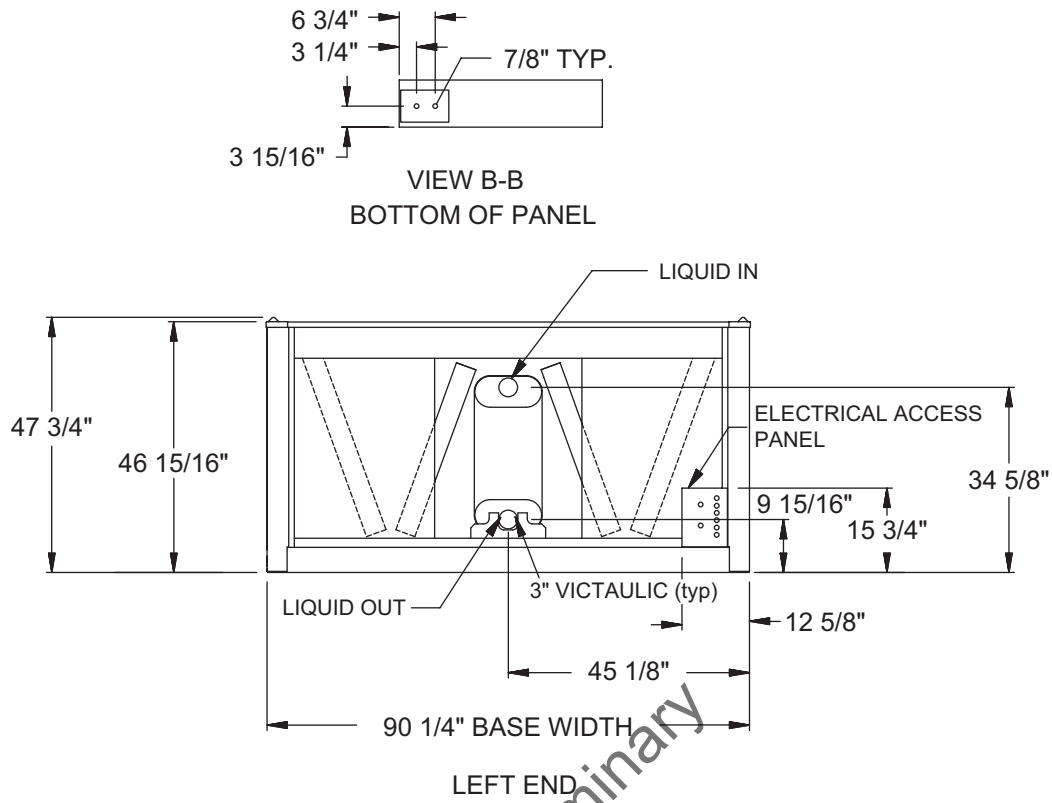

Preliminary

Aluminum		
YCAL	Center of Gravity (in.)	
	X	Y
0051	59.2	42.6

Copper		
YCAL	Center of Gravity (in.)	
	X	Y
0051	64.3	42.9

NOTE:

Placement on a level surface of free of obstructions (including snow, for winter operation) or air circulation ensures rated performance, reliable operation, and ease of maintenance. Site restrictions may compromise minimum clearances indicated below, resulting in unpredictable airflow patterns and possible diminished performance. YORK's unit controls will optimize operation without nuisance high-pressure safety cutouts; however, the system designer must consider potential performance degradation. Recommended minimum clearances: front to wall - 6'; rear to wall - 6'; cooler end to wall - 4'0"; coil end to wall - 6'; top - no obstructions allowed; distance between adjacent units - 10'. No more than one adjacent wall may be higher than the unit. 1" nominal deflection isolators (not shown) will increase overall unit height by 6".

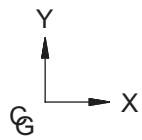
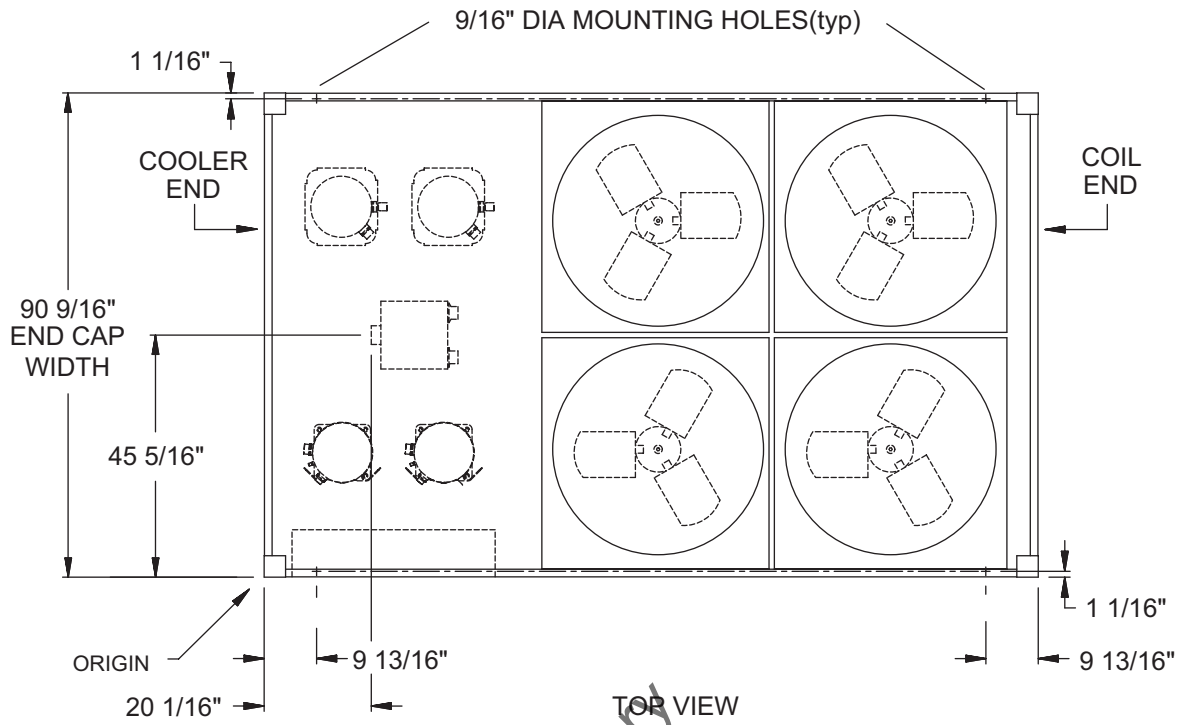

Preliminary

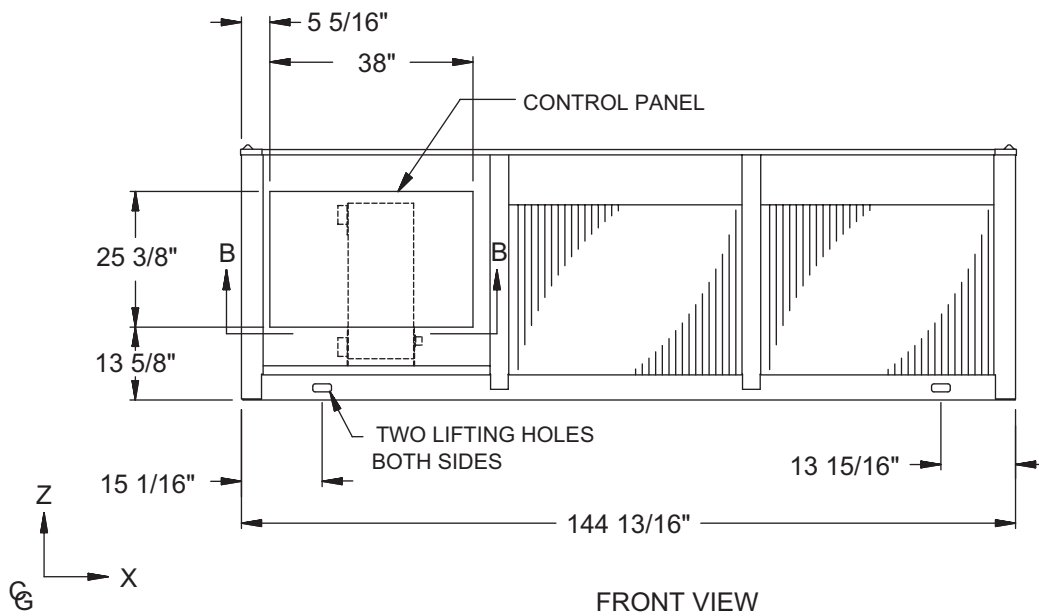

Dimensions - YCAL0055EC - (English)

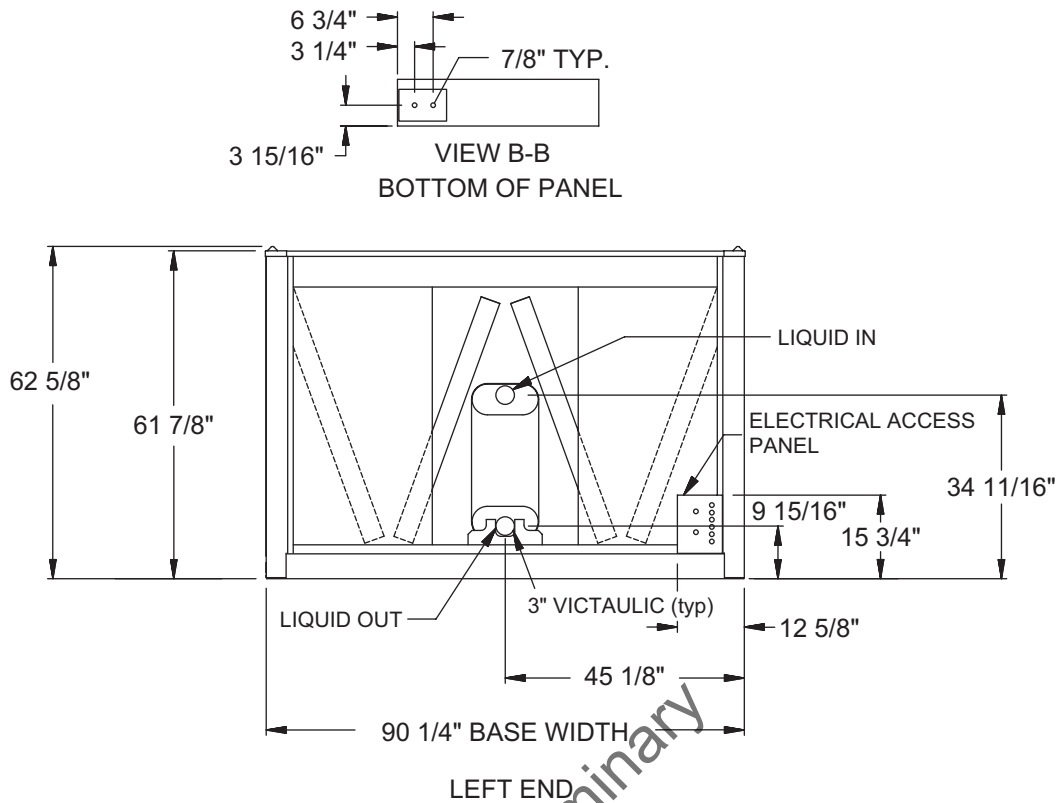

Preliminary

Aluminum		
YCAL	Center of Gravity (in.)	
	X	Y
0055	57.9	43.0

Copper		
YCAL	Center of Gravity (in.)	
	X	Y
0055	62.5	43.2

NOTE:

Placement on a level surface of free of obstructions (including snow, for winter operation) or air circulation ensures rated performance, reliable operation, and ease of maintenance. Site restrictions may compromise minimum clearances indicated below, resulting in unpredictable airflow patterns and possible diminished performance. YORK's unit controls will optimize operation without nuisance high-pressure safety cutouts; however, the system designer must consider potential performance degradation. Recommended minimum clearances: front to wall - 6'; rear to wall - 6'; cooler end to wall - 4'0"; coil end to wall - 6'; top - no obstructions allowed; distance between adjacent units - 10'. No more than one adjacent wall may be higher than the unit. 1" nominal deflection isolators (not shown) will increase overall unit height by 6".

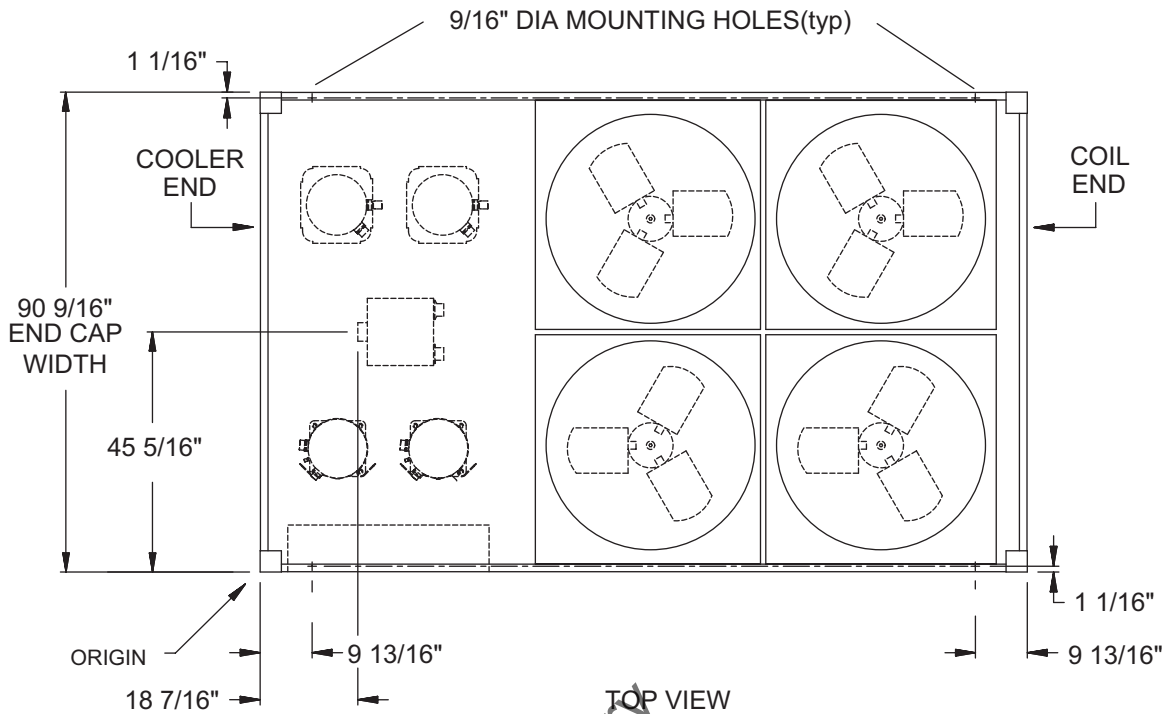

TOP VIEW

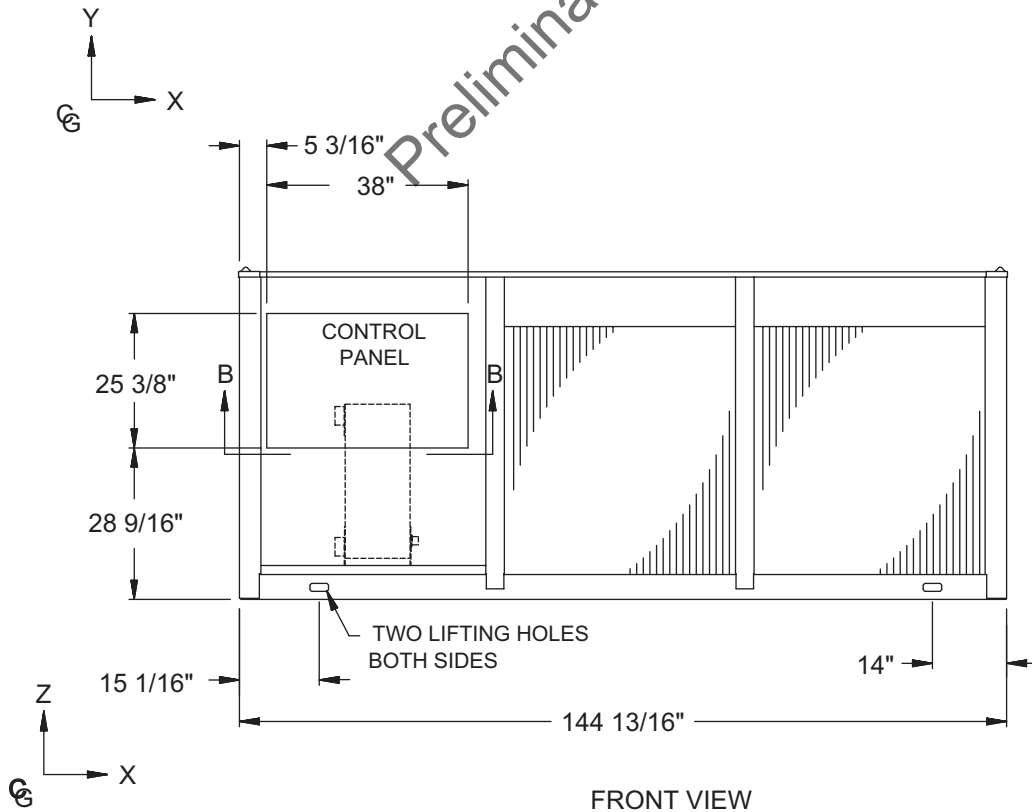

FRONT VIEW

Dimensions - YCAL0061 (English)

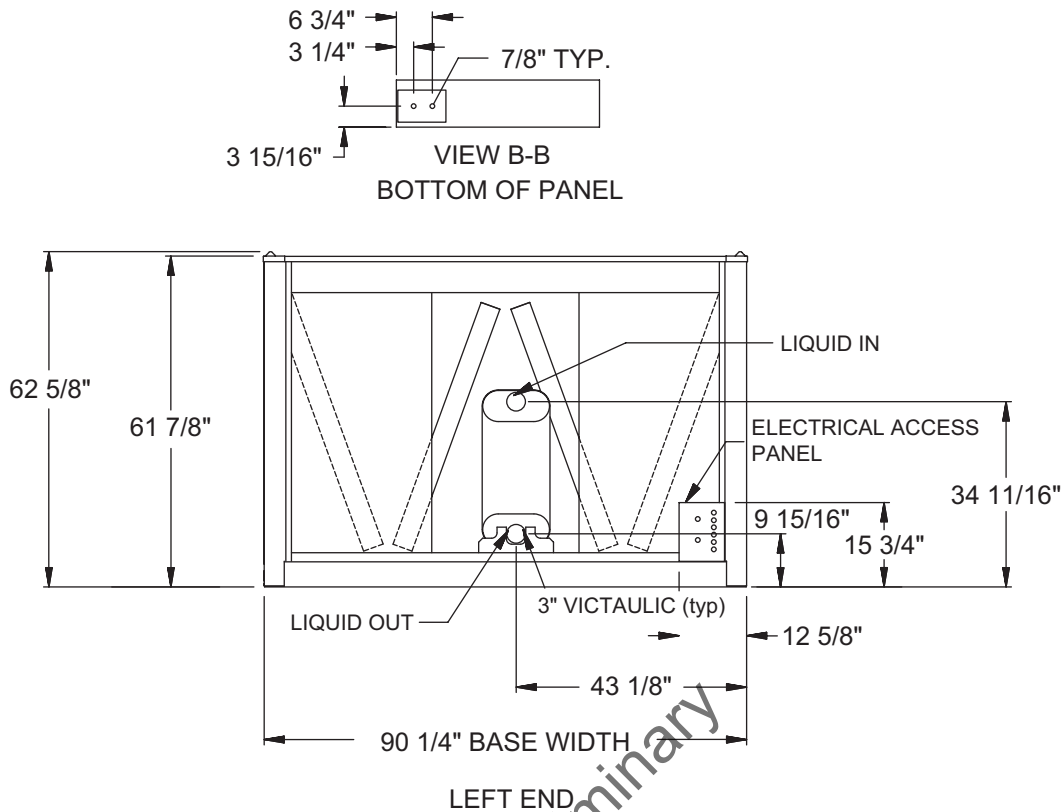

Preliminary

Aluminum		
YCAL	Center of Gravity (in.)	
	X	Y
0061	56.6	45.2

Copper		
YCAL	Center of Gravity (in.)	
	X	Y
0061	61.8	45.8

NOTE:

Placement on a level surface of free of obstructions (including snow, for winter operation) or air circulation ensures rated performance, reliable operation, and ease of maintenance. Site restrictions may compromise minimum clearances indicated below, resulting in unpredictable airflow patterns and possible diminished performance. YORK's unit controls will optimize operation without nuisance high-pressure safety cutouts; however, the system designer must consider potential performance degradation. Recommended minimum clearances: front to wall - 6"; rear to wall - 6"; cooler end to wall - 4'0"; coil end to wall - 6"; top - no obstructions allowed; distance between adjacent units - 10". No more than one adjacent wall may be higher than the unit. 1" nominal deflection isolators (not shown) will increase overall unit height by 6".

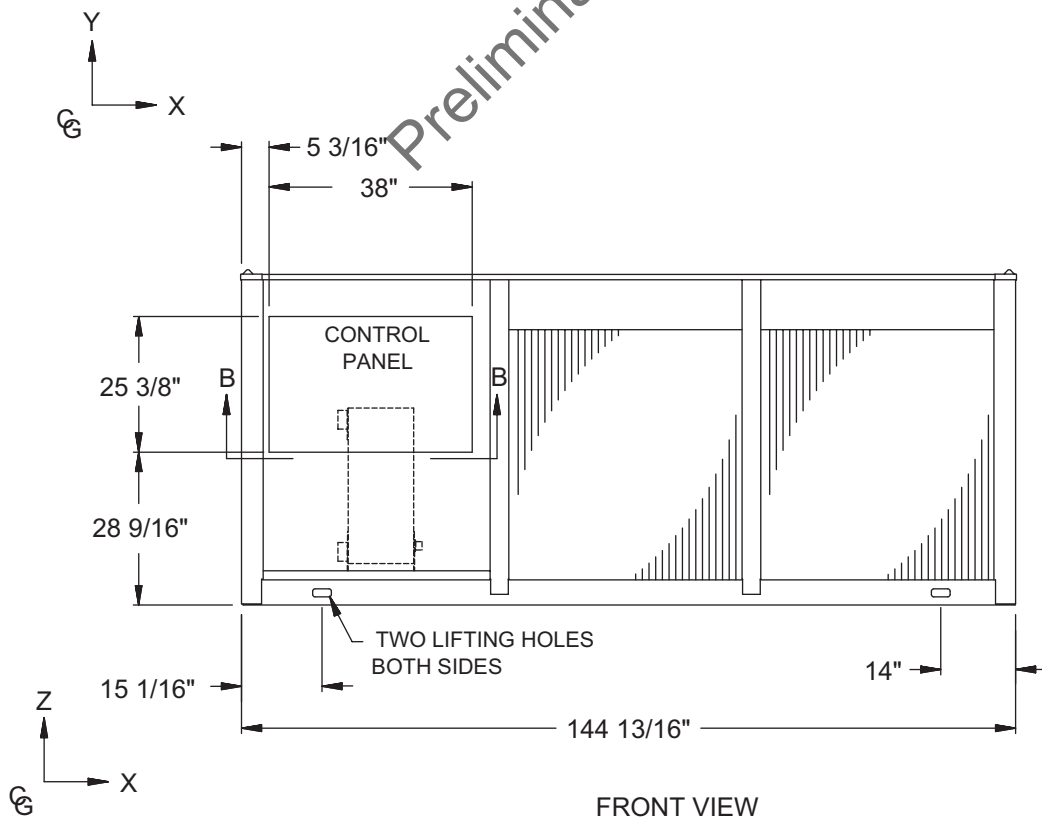
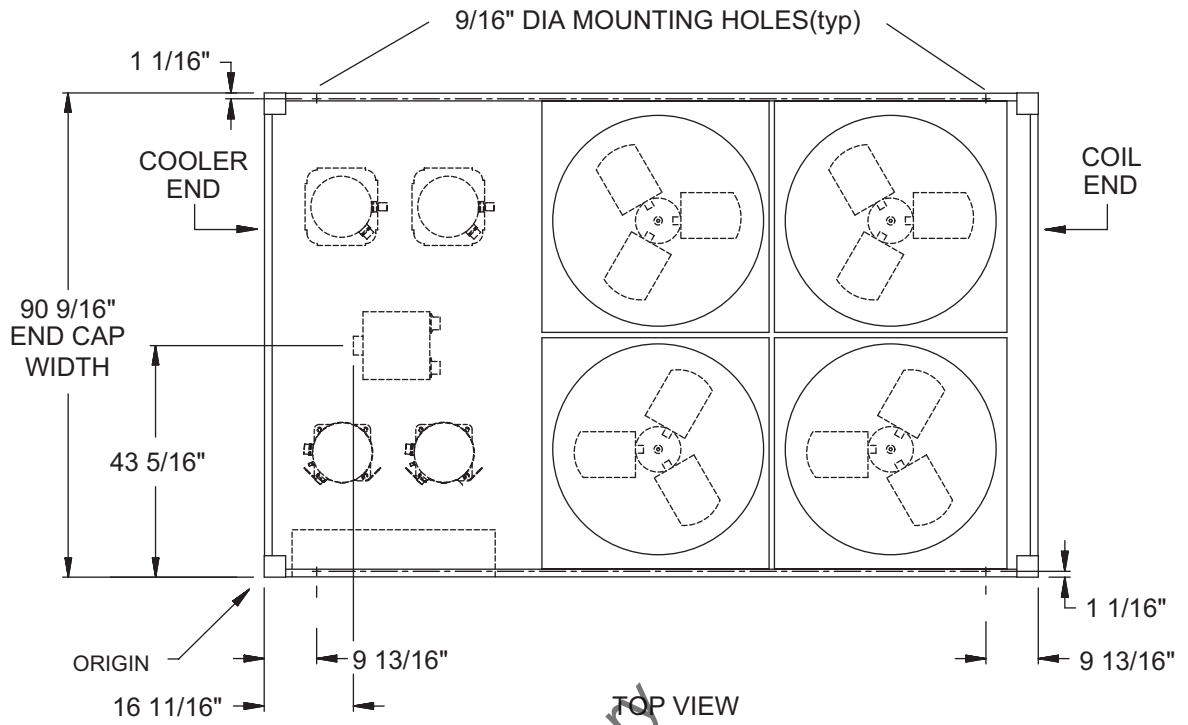

Dimensions - YCAL0065 (English)

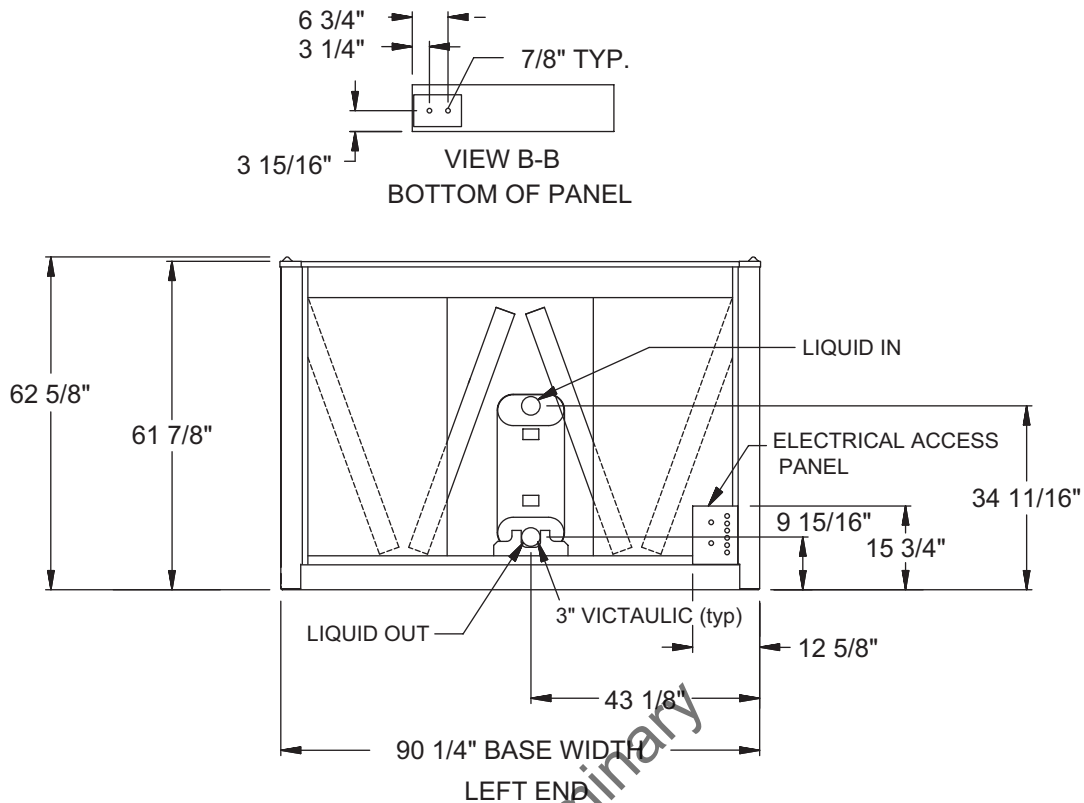

Preliminary

Aluminum		
YCAL	Center of Gravity (in.)	
	X	Y
0065	59.7	44.9

Copper		
YCAL	Center of Gravity (in.)	
	X	Y
0065	65.2	44.9

NOTE:

Placement on a level surface of free of obstructions (including snow, for winter operation) or air circulation ensures rated performance, reliable operation, and ease of maintenance. Site restrictions may compromise minimum clearances indicated below, resulting in unpredictable airflow patterns and possible diminished performance. YORK's unit controls will optimize operation without nuisance high-pressure safety cutouts; however, the system designer must consider potential performance degradation. Recommended minimum clearances: front to wall - 6'; rear to wall - 6'; cooler end to wall - 4'0"; coil end to wall - 6'; top - no obstructions allowed; distance between adjacent units - 10'. No more than one adjacent wall may be higher than the unit. 1" nominal deflection isolators (not shown) will increase overall unit height by 6".

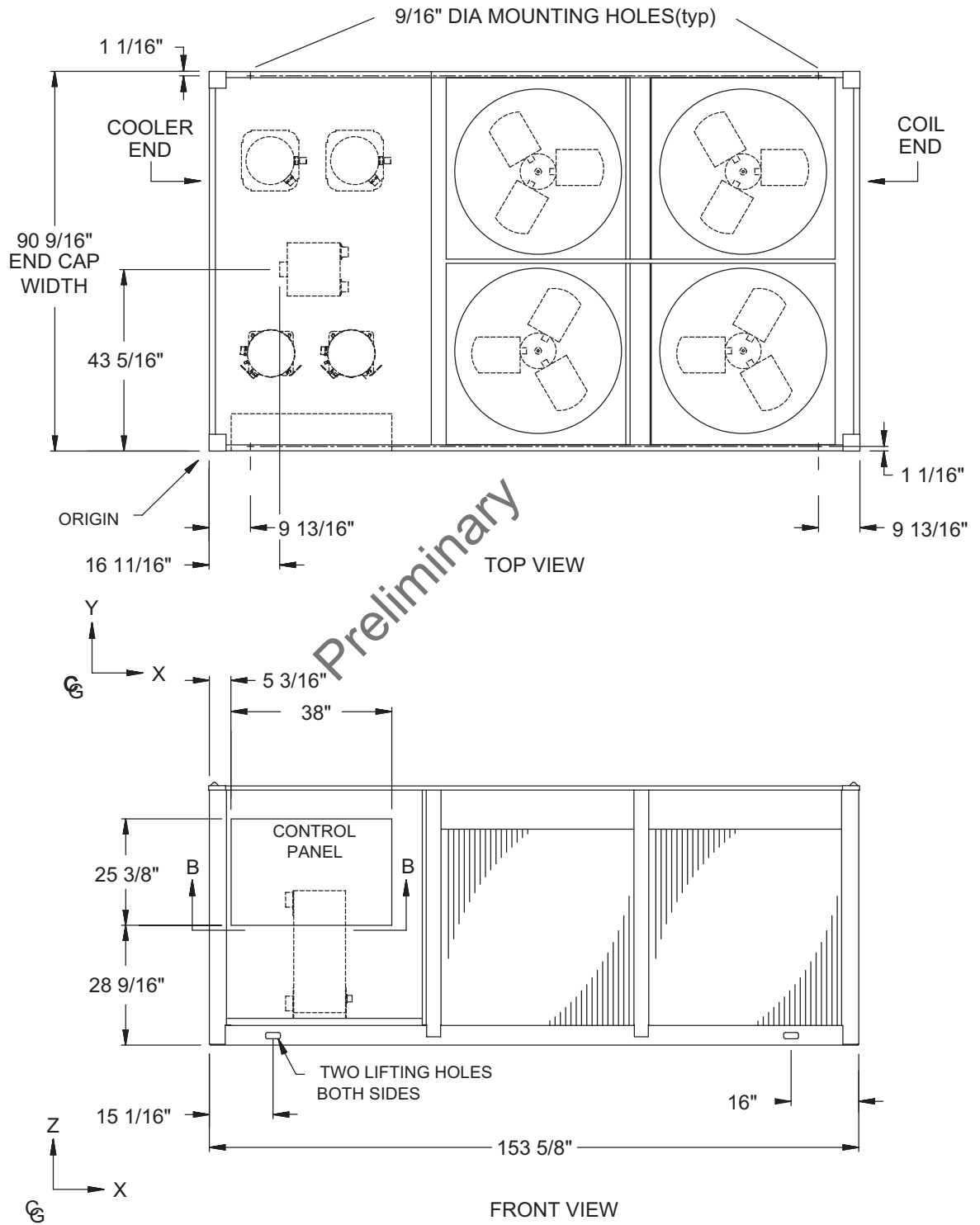

Dimensions - YCAL0041 (SI)

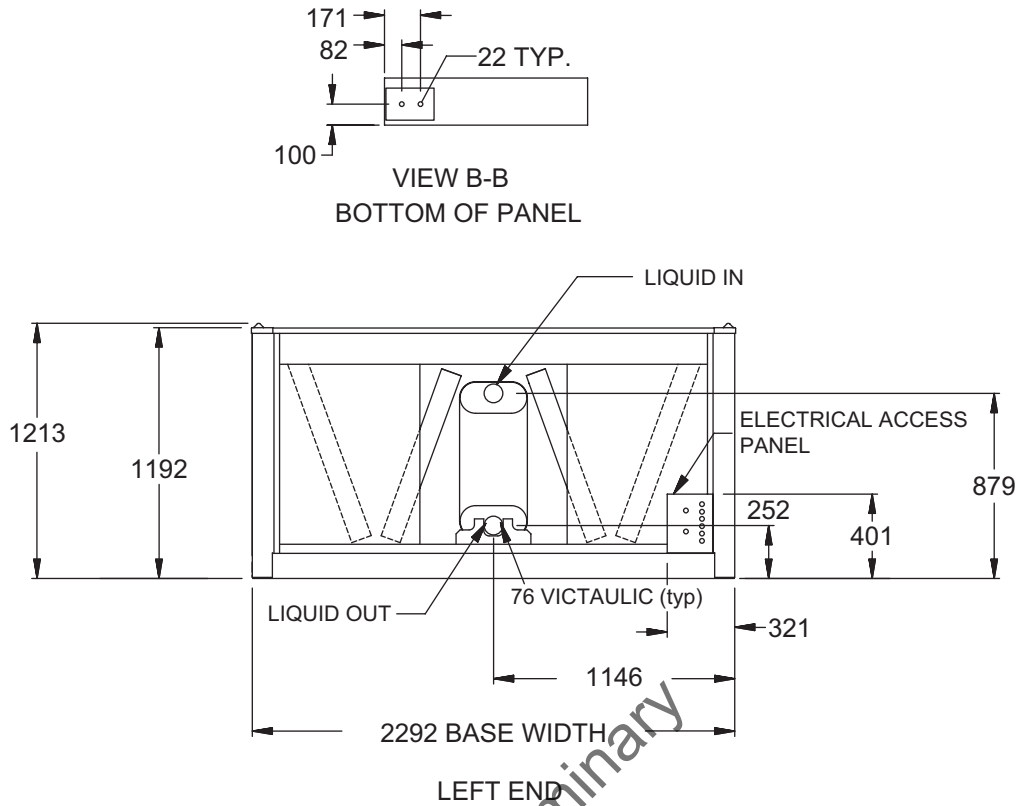

Aluminum		
YCAL	Center of Gravity (in.)	
	X	Y
0041	1513.7	1107.0

Copper		
YCAL	Center of Gravity (in.)	
	X	Y
0041	1616.1	1111.1

NOTE: All dimensions are in mm unless specified otherwise.

NOTE:

Placement on a level surface of free of obstructions (including snow, for winter operation) or air circulation ensures rated performance, reliable operation, and ease of maintenance. Site restrictions may compromise minimum clearances indicated below, resulting in unpredictable airflow patterns and possible diminished performance. YORK's unit controls will optimize operation without nuisance high-pressure safety cutouts; however, the system designer must consider potential performance degradation. Recommended minimum clearances: front to wall – 2m; rear to wall – 2m; cooler end to wall – 1.2m; coil end to wall - 2m; top – no obstructions allowed; distance between adjacent units – 3m. No more than one adjacent wall may be higher than the unit. 1" nominal deflection isolators (not shown) will increase overall unit height by 152mm.

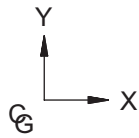
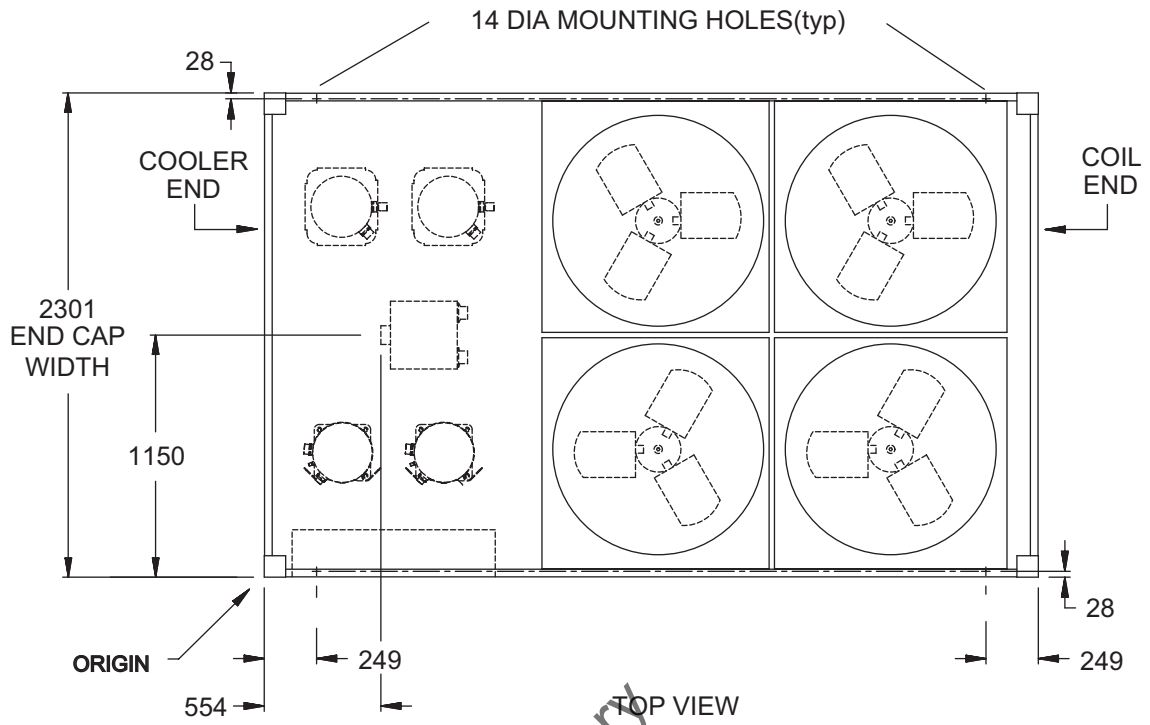

Preliminary

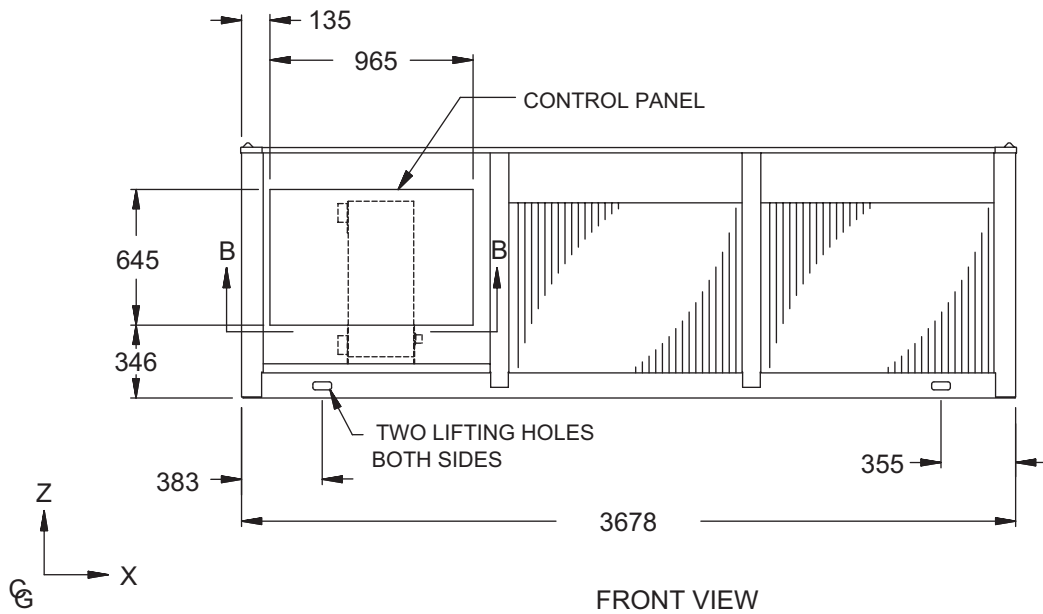

Dimensions - YCAL0045 (SI)

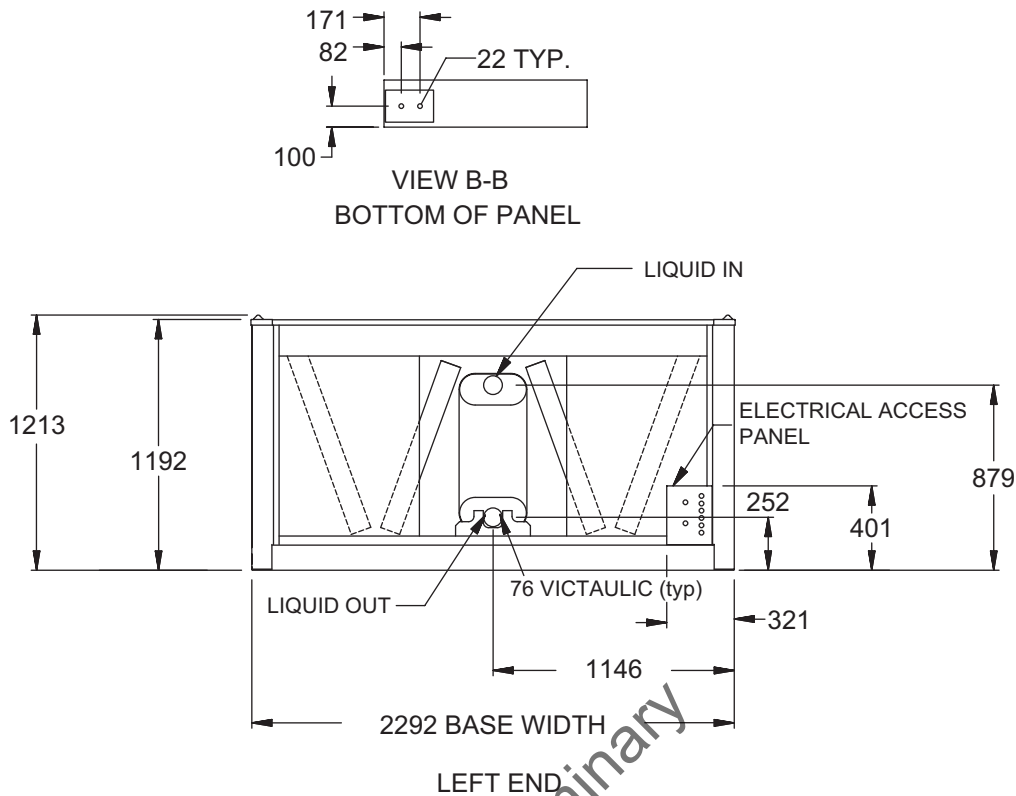

Preliminary

Aluminum		
YCAL	Center of Gravity (in.)	
	X	Y
0045	1503.5	1105.5

Copper		
YCAL	Center of Gravity (in.)	
	X	Y
0045	1605.9	1109.7

NOTE: All dimensions are in mm unless specified otherwise.

NOTE:

Placement on a level surface of free of obstructions (including snow, for winter operation) or air circulation ensures rated performance, reliable operation, and ease of maintenance. Site restrictions may compromise minimum clearances indicated below, resulting in unpredictable airflow patterns and possible diminished performance. YORK's unit controls will optimize operation without nuisance high-pressure safety cutouts; however, the system designer must consider potential performance degradation. Recommended minimum clearances: front to wall – 2m; rear to wall – 2m; cooler end to wall – 1.2m; coil end to wall - 2m; top – no obstructions allowed; distance between adjacent units – 3m. No more than one adjacent wall may be higher than the unit. 1" nominal deflection isolators (not shown) will increase overall unit height by 152mm.

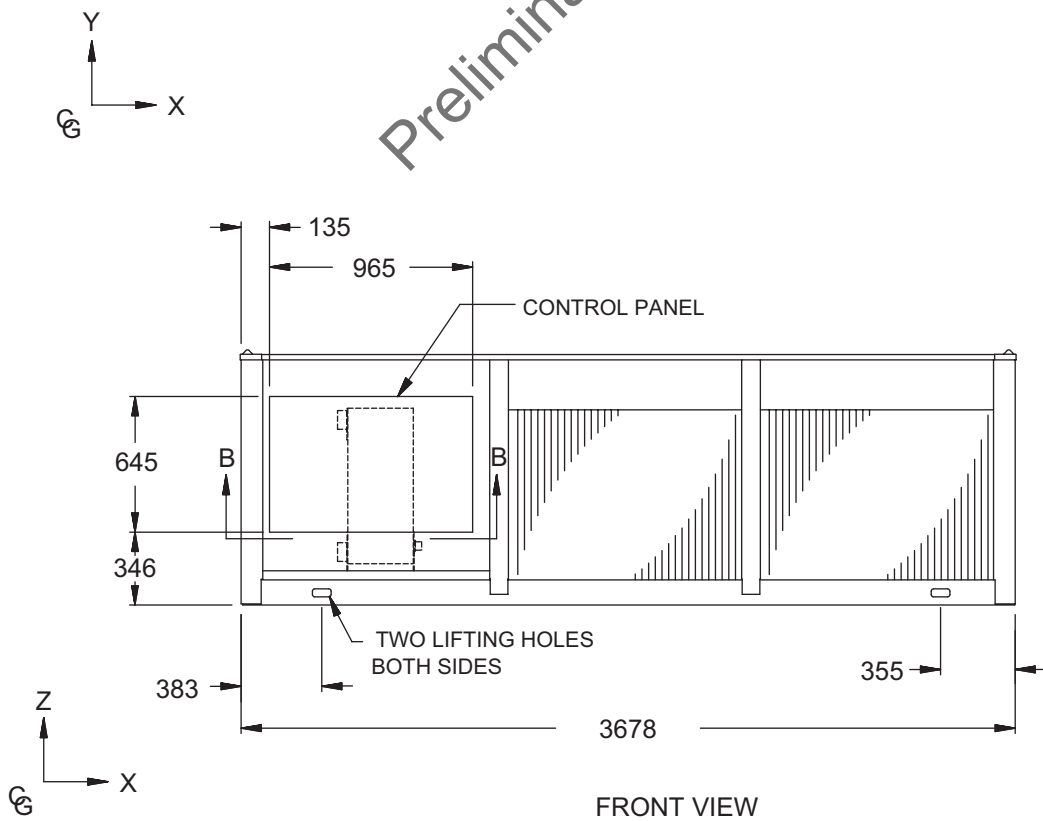
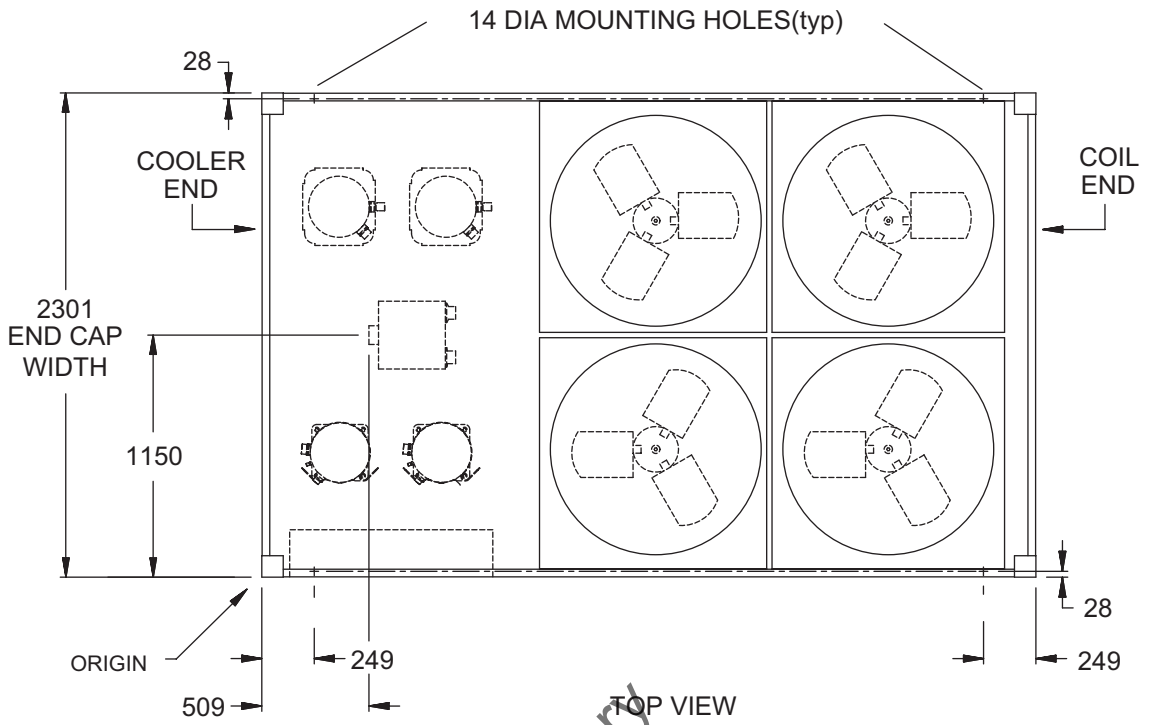

Dimensions - YCAL0051 (SI)

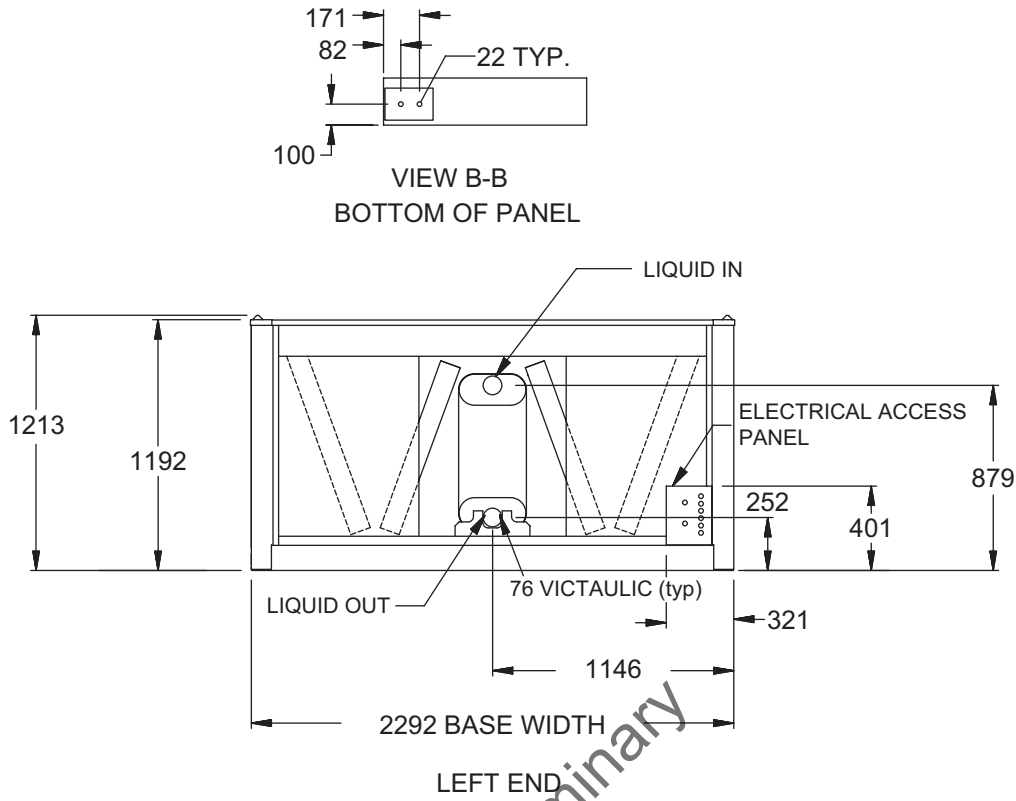

Preliminary

Aluminum		
YCAL	Center of Gravity (in.)	
	X	Y
0051	1504.6	1082.4

Copper		
YCAL	Center of Gravity (in.)	
	X	Y
0051	1633.0	1090.8

NOTE: All dimensions are in mm unless specified otherwise.

NOTE:

Placement on a level surface of free of obstructions (including snow, for winter operation) or air circulation ensures rated performance, reliable operation, and ease of maintenance. Site restrictions may compromise minimum clearances indicated below, resulting in unpredictable airflow patterns and possible diminished performance. YORK's unit controls will optimize operation without nuisance high-pressure safety cutouts; however, the system designer must consider potential performance degradation. Recommended minimum clearances: front to wall – 2m; rear to wall – 2m; cooler end to wall – 1.2m; coil end to wall - 2m; top – no obstructions allowed; distance between adjacent units – 3m. No more than one adjacent wall may be higher than the unit. 1" nominal deflection isolators (not shown) will increase overall unit height by 152mm.

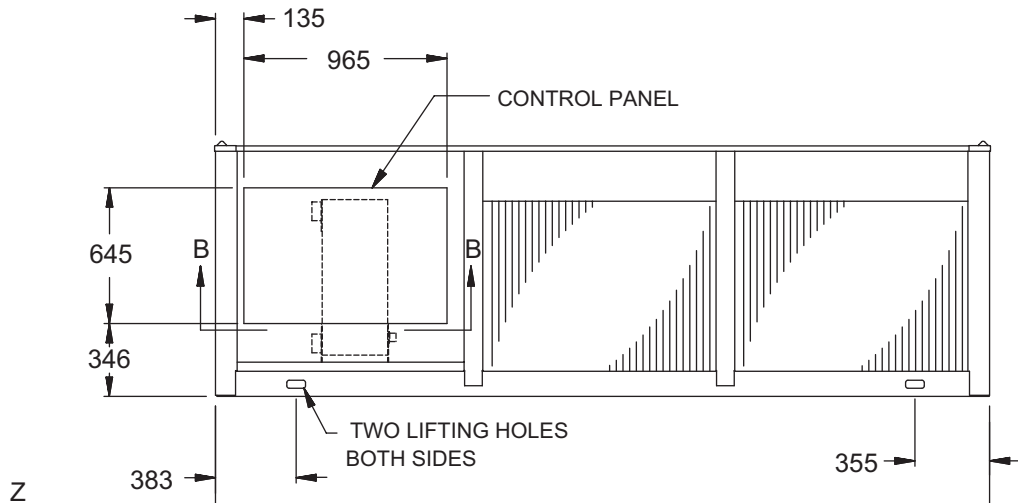
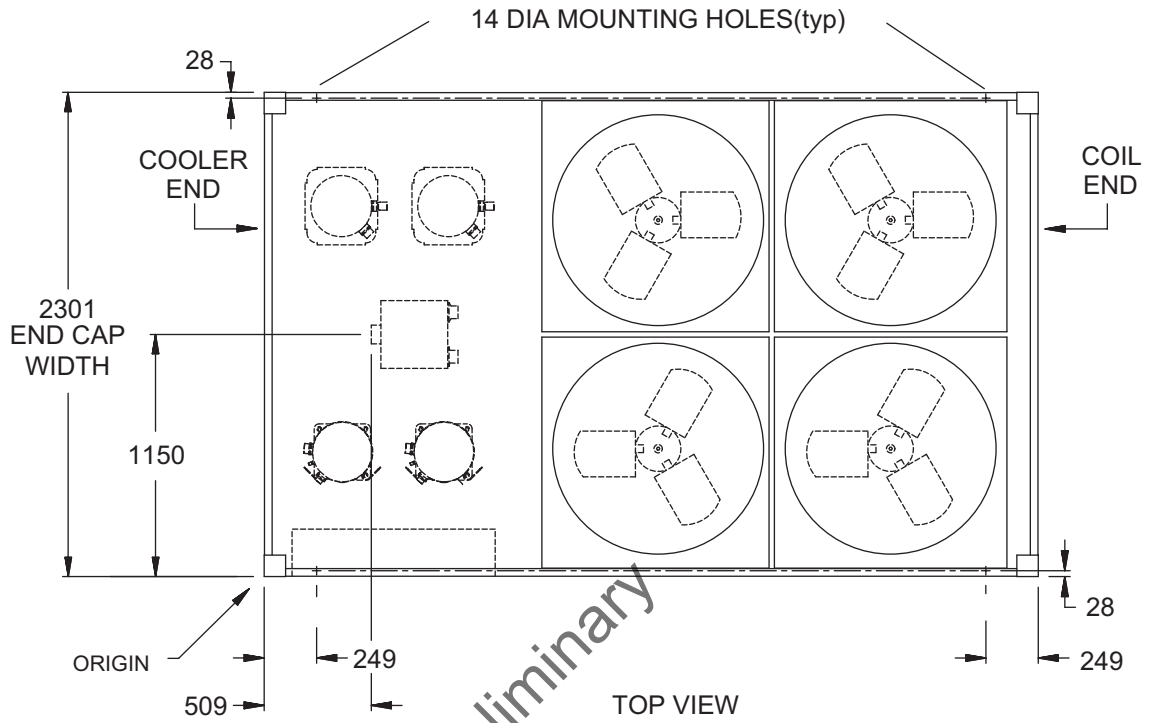

Dimensions -YCAL0055 (SI)

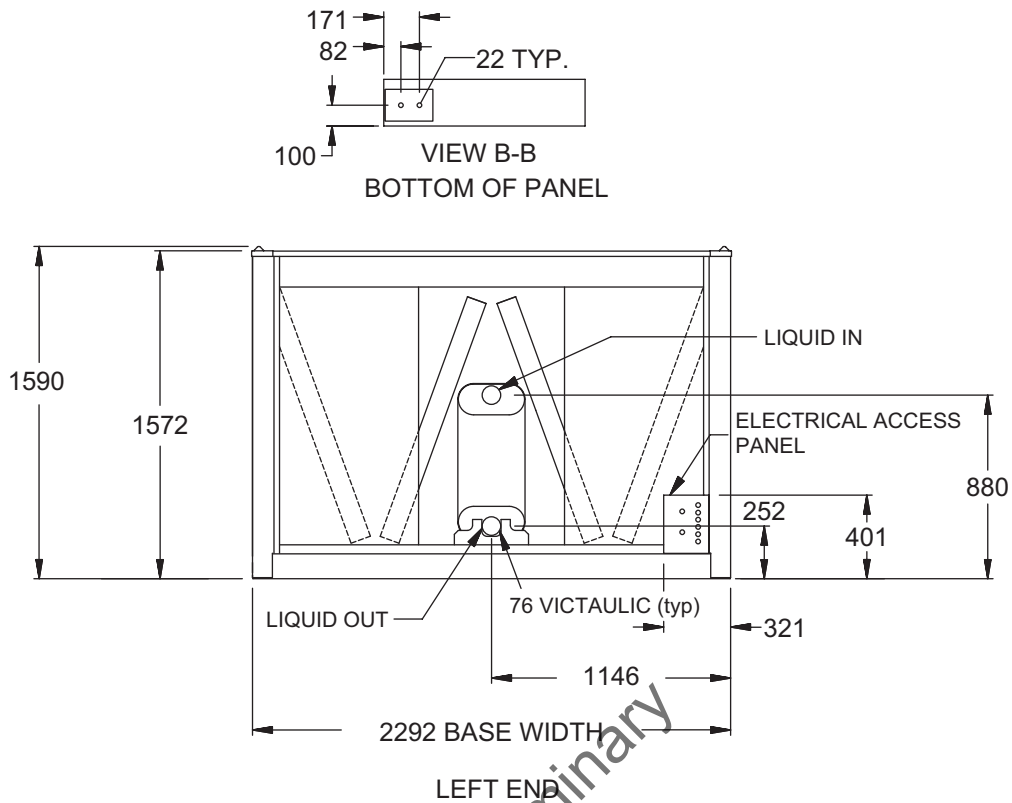

Preliminary

Aluminum		
YCAL	Center of Gravity (in.)	
	X	Y
0055	1470.3	1092.0

Copper		
YCAL	Center of Gravity (in.)	
	X	Y
0055	1586.9	1098.3

NOTE: All dimensions are in mm unless specified otherwise.

NOTE:

Placement on a level surface of free of obstructions (including snow, for winter operation) or air circulation ensures rated performance, reliable operation, and ease of maintenance. Site restrictions may compromise minimum clearances indicated below, resulting in unpredictable airflow patterns and possible diminished performance. YORK's unit controls will optimize operation without nuisance high-pressure safety cutouts; however, the system designer must consider potential performance degradation. Recommended minimum clearances: front to wall – 2m; rear to wall – 2m; cooler end to wall – 1.2m; coil end to wall - 2m; top – no obstructions allowed; distance between adjacent units – 3m. No more than one adjacent wall may be higher than the unit. 1" nominal deflection isolators (not shown) will increase overall unit height by 152mm.

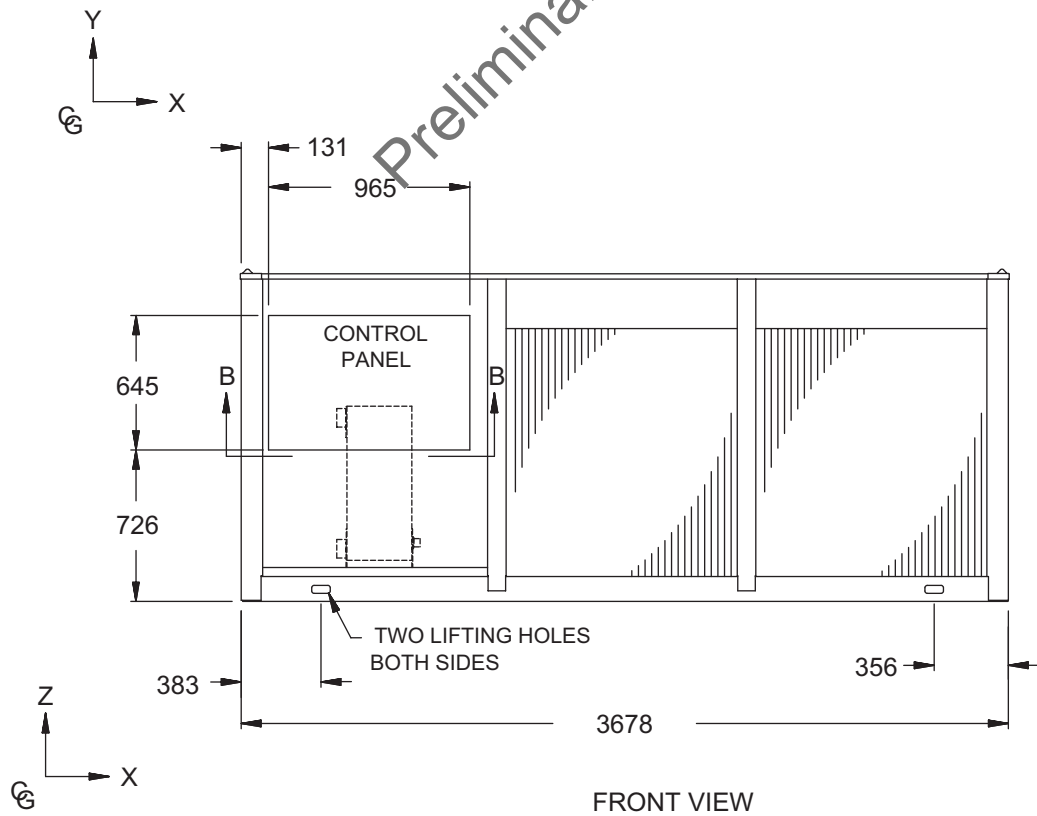
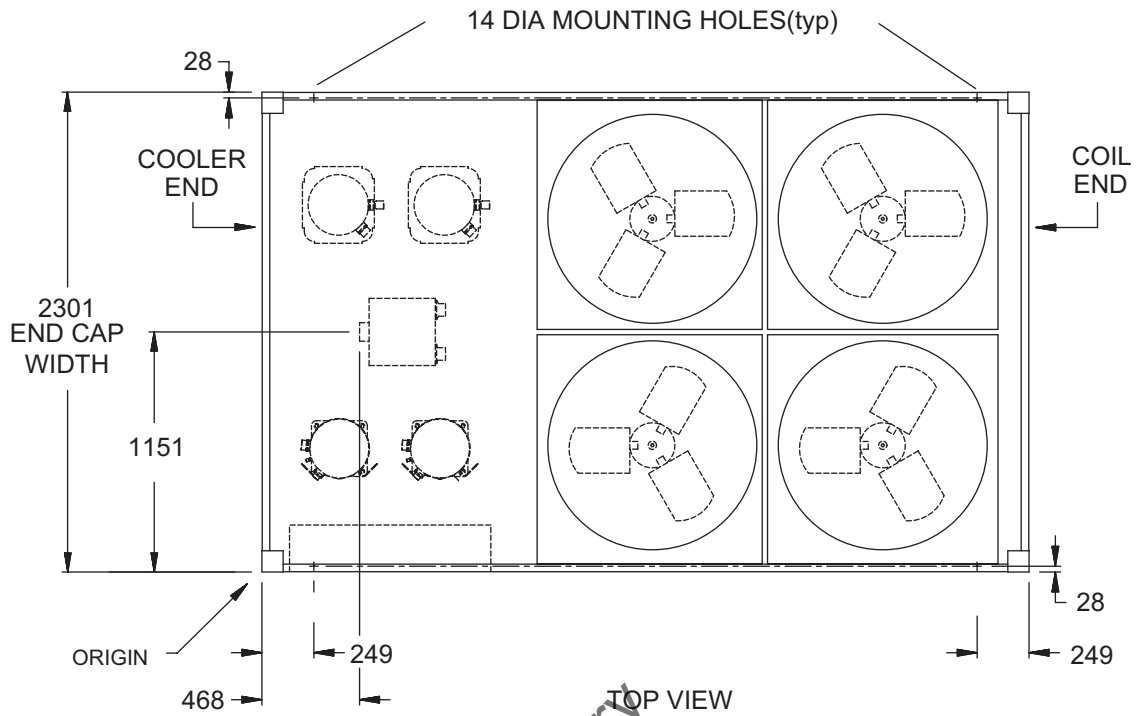

Dimensions - YCAL0061 (SI)

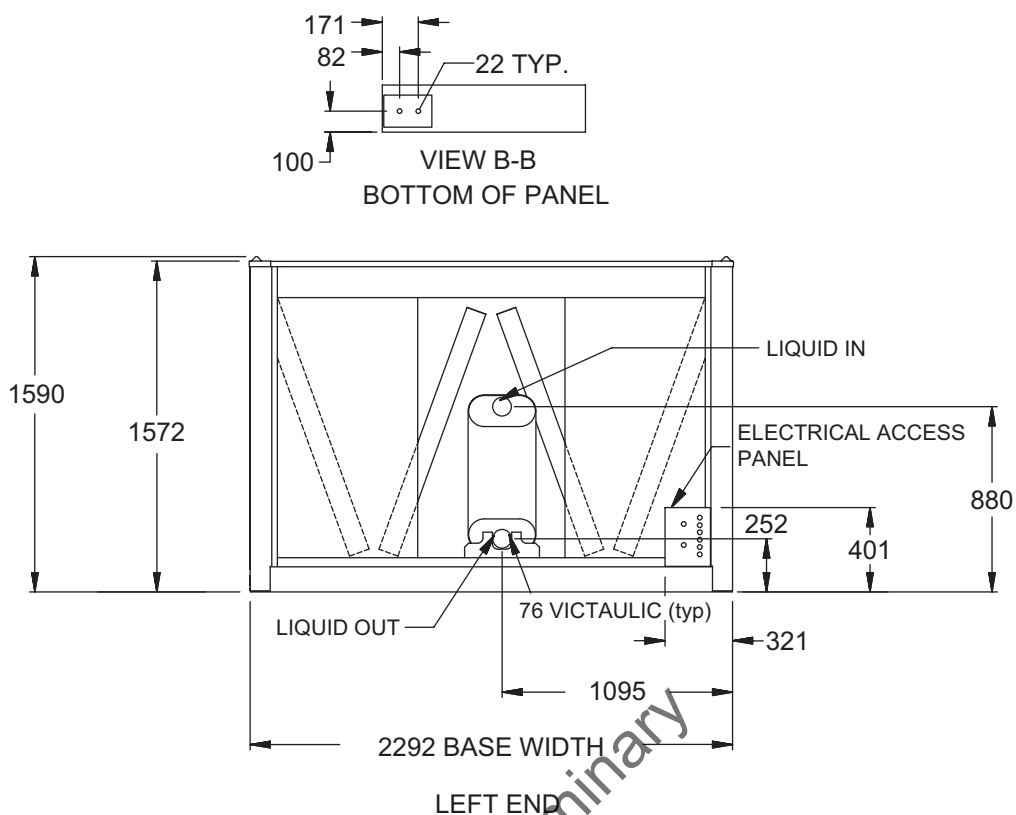

Preliminary

Aluminum		
YCAL	Center of Gravity (in.)	
	X	Y
0061	1438.0	1147.1

Copper		
YCAL	Center of Gravity (in.)	
	X	Y
0061	1569.3	1162.9

NOTE: All dimensions are in mm unless specified otherwise.

NOTE:

Placement on a level surface of free of obstructions (including snow, for winter operation) or air circulation ensures rated performance, reliable operation, and ease of maintenance. Site restrictions may compromise minimum clearances indicated below, resulting in unpredictable airflow patterns and possible diminished performance. YORK's unit controls will optimize operation without nuisance high-pressure safety cutouts; however, the system designer must consider potential performance degradation. Recommended minimum clearances: front to wall – 2m; rear to wall – 2m; cooler end to wall – 1.2m; coil end to wall - 2m; top – no obstructions allowed; distance between adjacent units – 3m. No more than one adjacent wall may be higher than the unit. 1" nominal deflection isolators (not shown) will increase overall unit height by 152mm.

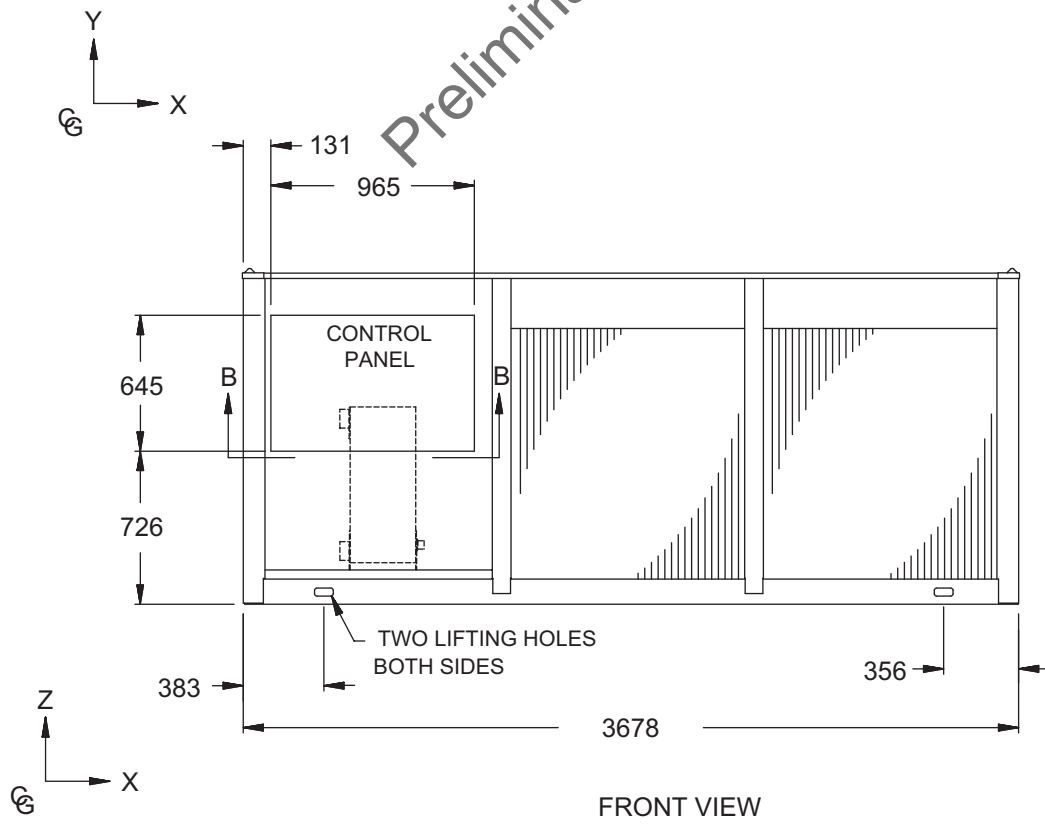
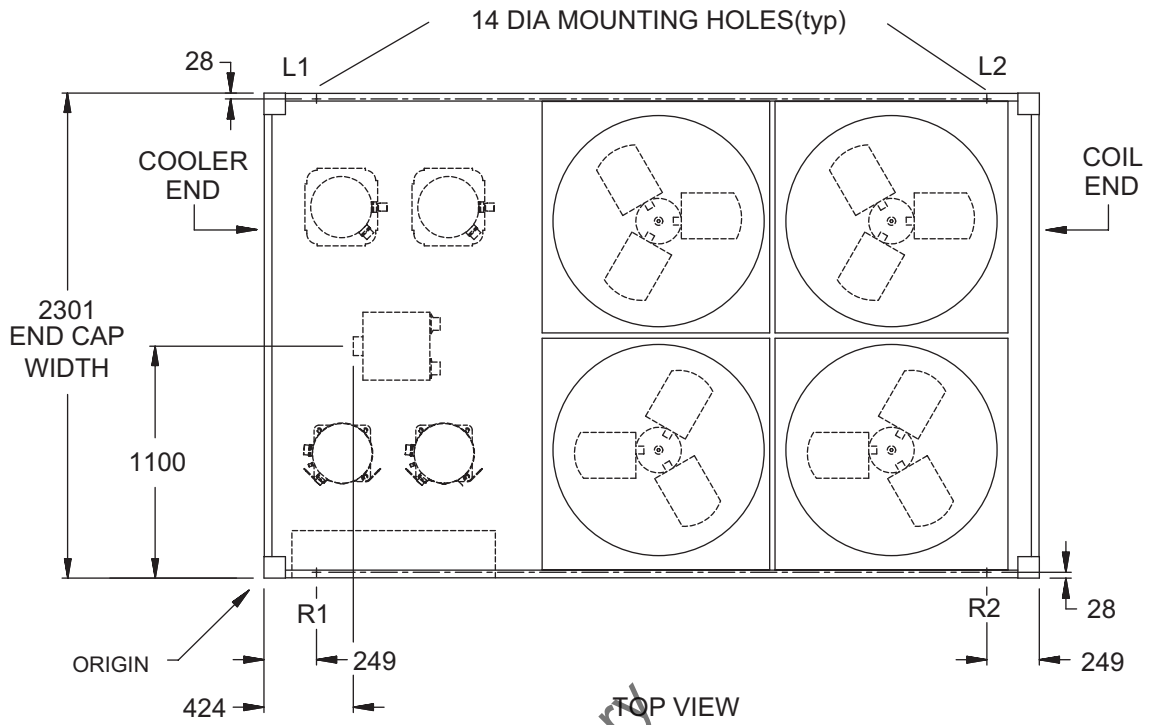

Dimensions - YCAL0065 (SI)

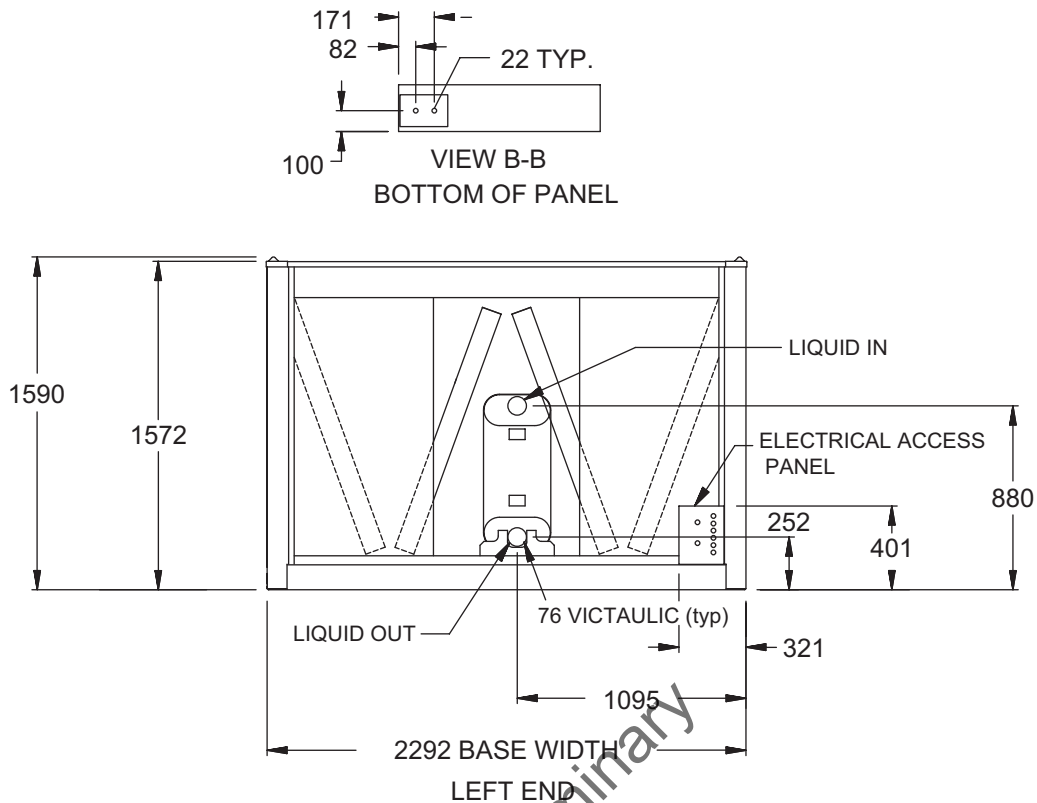

Preliminary

Aluminum		
YCAL	Center of Gravity (in.)	
	X	Y
0065	1517.6	1140.3

Copper		
YCAL	Center of Gravity (in.)	
	X	Y
0065	1655.5	1141.1

NOTE: All dimensions are in mm unless specified otherwise.

NOTE:

Placement on a level surface of free of obstructions (including snow, for winter operation) or air circulation ensures rated performance, reliable operation, and ease of maintenance. Site restrictions may compromise minimum clearances indicated below, resulting in unpredictable airflow patterns and possible diminished performance. YORK's unit controls will optimize operation without nuisance high-pressure safety cutouts; however, the system designer must consider potential performance degradation. Recommended minimum clearances: front to wall – 2m; rear to wall – 2m; cooler end to wall – 1.2m; coil end to wall - 2m; top – no obstructions allowed; distance between adjacent units – 3m. No more than one adjacent wall may be higher than the unit. 1" nominal deflection isolators (not shown) will increase overall unit height by 152mm.

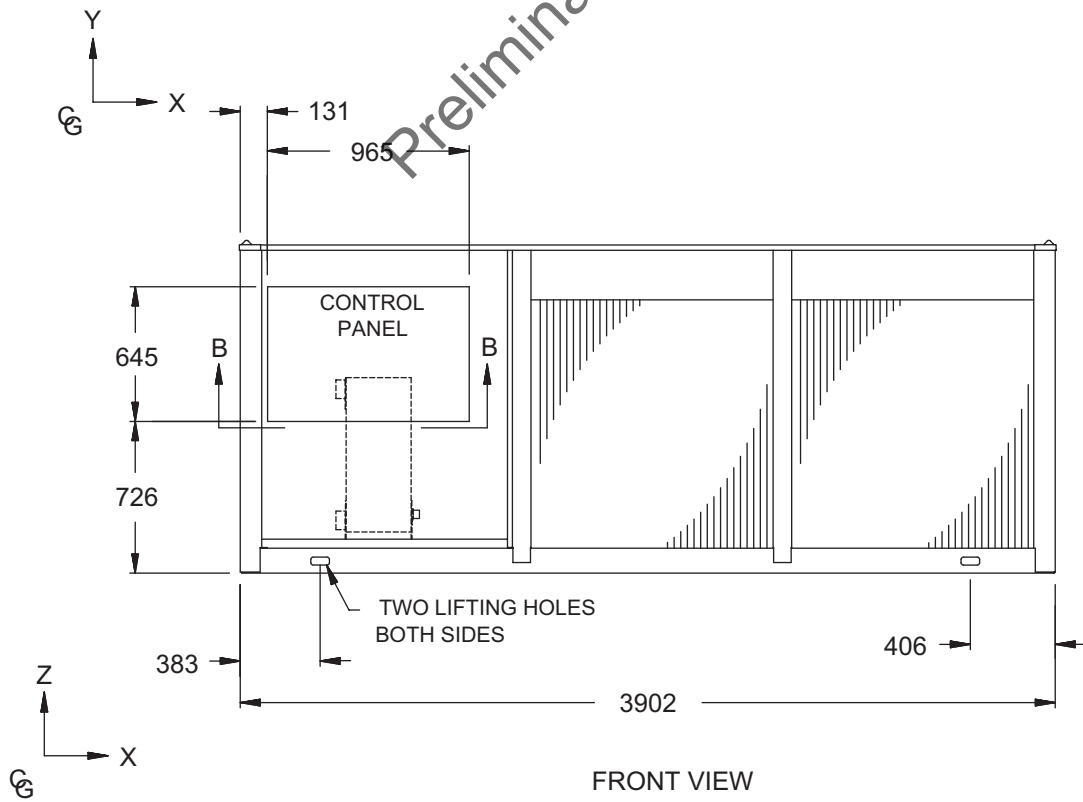
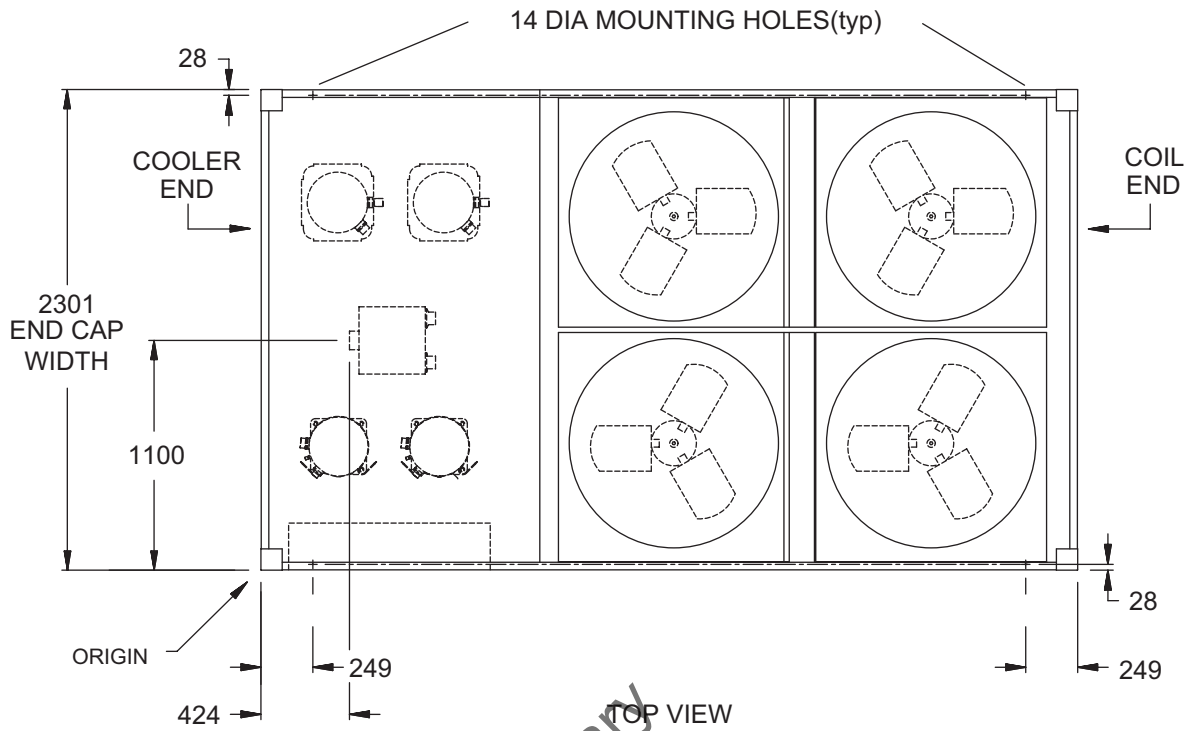

Isolator Selections

ONE INCH DEFLECTION SPRING ISOLATOR CROSS-REFERENCE

Illustration shows single spring CIP-B or CIP-C mount.

CIP-X-

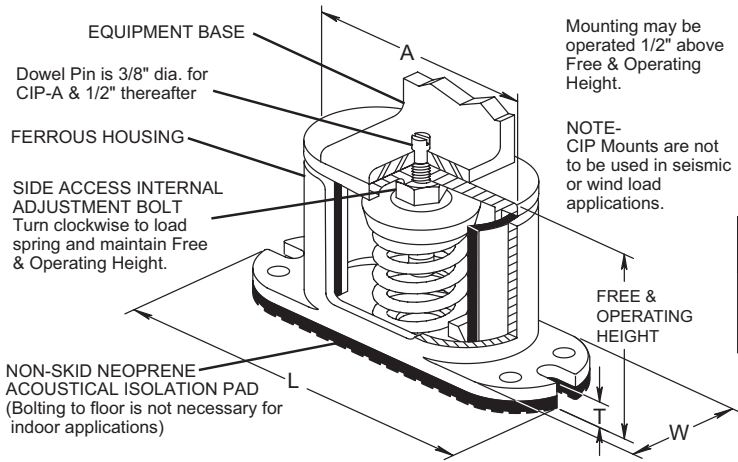

Mounting may be operated 1/2" above Free & Operating Height.

NOTE- CIP Mounts are not to be used in seismic or wind load applications.

TYPE CIP DIMENSIONS (inches)†

Size	A	L	T	W	SW	HCL	HCW	MBD	SBC	Free Ht.	Min Ht.
CIP-B	5 ³ / ₄	8 ¹ / ₄	1/2	2 ³ / ₄	7/16	6 ¹ / ₂	1 ¹ / ₂	3/8	7 ¹ / ₄	6 ¹ / ₈	5 ¹ / ₄
CIP-C	6 ⁵ / ₈	8 ⁷ / ₈	9/16	3 ¹ / ₂	7/16	7 ¹ / ₄	1 ³ / ₄	3/8	7 ⁷ / ₈	6 ³ / ₄	6 ³ / ₄

†Casting dimensions may vary ±1/8"

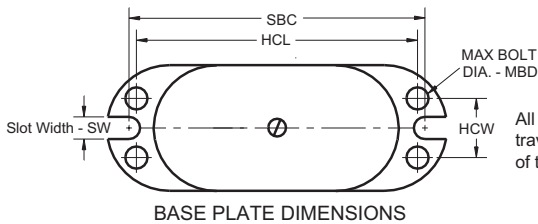

All springs have additional travel to solid equal to 50% of the rated deflection.

FOR UNITS WITH ALL POINT LOADS LESS THAN 1404 LBS (637 KG)

Weight Range (lbs)	Weight Range (kg)	Model Number	Color
239 to 384 lbs	108 to 174 kg	CIP-B-	Red
384 to 639 lbs	174 to 290 kg	CIP-B-	White
639 to 851 lbs	290 to 386 kg	CIP-B-	Blue
851 to 1064 lbs	386 to 483 kg	CIP-B-	Gray
1064 to 1404 lbs	483 to 637 kg	CIP-B-	Black

FOR UNITS WITH ANY POINT LOAD ABOVE 1404 LBS (637 KG)

Weight Range (lbs)	Weight Range (kg)	Model Number	Color
Up to 851 lbs	Up to 386 kg	CIP-C-	Black
851 to 1149 lbs	386 to 521 kg	CIP-C-	Yellow
1149 to 1489 lbs	521 to 675 kg	CIP-C-	Black
1489 to 1786 lbs	675 to 910 kg	CIP-C-	Yellow w/ Red
1786 to 2028 lbs	910 to 920 kg	CIP-C-	Yellow w/ Green
2028 to 2254 lbs	920 to 1022 kg	CIP-C-	Red w/ Red
2254 to 2936 lbs	1022 to 1332 kg	CIP-C-	Red w/ Green

NEOPRENE ISOLATOR CROSS-REFERENCE

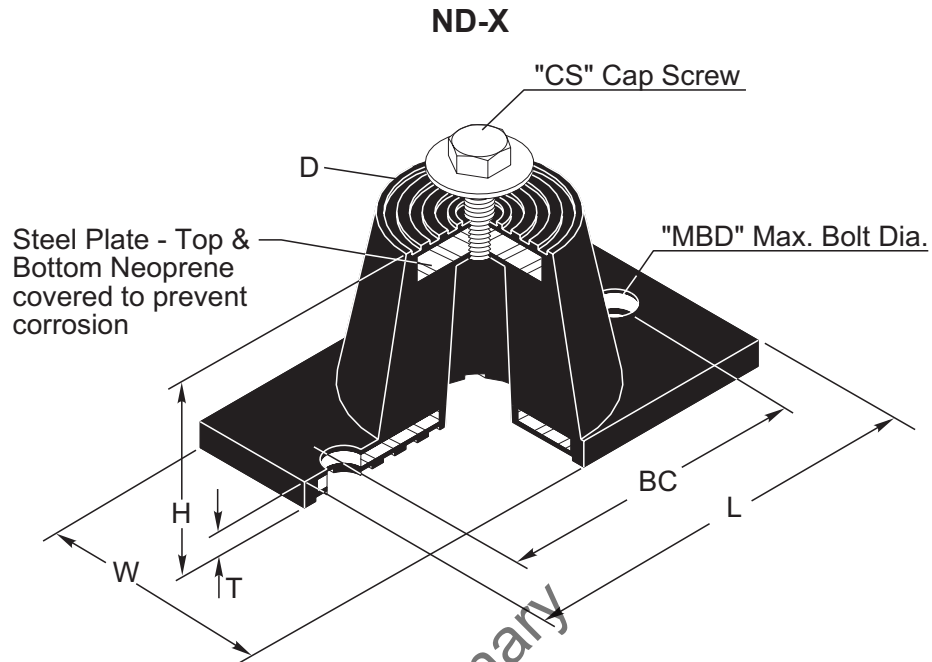

ENGLISH								
Size	D	H	T	W	BC	CS	MBD	
ND-C	2 9/16	2 3/4	5 1/2	1/4	2 5/16	4 1/80	1/2- 13 x 1"	1/2"
ND-D	3 3/8	2 3/4	6 1/4	5/16	4	5	1/2- 13 x 1"	1/2"
ND-E	4 1/2	4 3/4	7 3/8	1/4	5 1/80	6 1/80	1/2- 13 x 1"	1/2"
SI								
ND-C	65.1	69.9	139.7	6.4	58.7	101.9	1/2- 13 x 1"	1/2"
ND-D	85.7	69.9	158.8	7.9	101.6	127.0	1/2- 13 x 1"	1/2"
ND-E	114.3	120.7	187.3	6.4	127.3	152.7	1/2- 13 x 1"	1/2"

Weight Range (lbs)	Weight Range (kg)	Model Number	Color
Up to 751 lbs	Up to 341 kg	ND-C	Yellow
751 to 1651 lbs	341 to 749 kg	ND-D	Yellow
1651 to 3226 lbs	749 to 1463 kg	ND-E	Yellow

Isolator Details (cont'd)

TWO INCH DEFLECTION, SEISMIC SPRING ISOLATOR CROSS-REFERENCE

SLRS

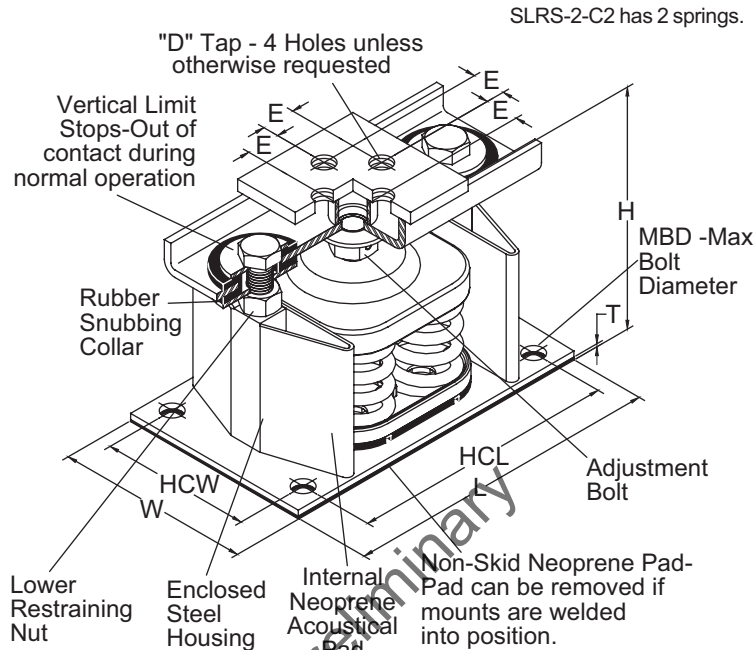

ENGLISH

SIZE	H	T	D	E	L	HCL	W	HCW	MBD
2-C2	8 1/2	3/8	5/8	1 3/8	14	12 1/4	5 1/4	3 1/2	5/8"

SI

SIZE	H	T	D	E	L	HCL	W	HCW	MBD
2-C2	215.9	9.5	15.9	34.9	355.6	311.2	133.4	88.9	5/8"

*Weight Range (lbs)	Weight Range (kg)	Model Number	Color
Up to 358 lbs	Up to 162 kg	SLRS-2-C2-	Red
358 to 443 lbs	162 to 201 kg	SLRS-2-C2-	White
443 to 582 lbs	201 to 264 kg	SLRS-2-C2-	Black
582 to 783 lbs	264 to 335 kg	SLRS-2-C2-	Blue
783 to 1038 lbs	335 to 471 kg	SLRS-2-C2-	Green
1038 to 1497 lbs	471 to 679 kg	SLRS-2-C2-	Gray
1497 to 2058 lbs	679 to 933 kg	SLRS-2-C2-	Silver
2058 to 2619 lbs	933 to 1188 kg	SLRS-2-C2-	Gray w/ red
2619 to 3180 lbs	1188 to 1442 kg	SLRS-2-C2-	Silver w/ red

INTENTIONALLY LEFT BLANK

Preliminary

Electrical Data

NOTES:

1. Minimum Circuit Ampacity (MCA) is based on 125% of the rated load amps for the largest motor plus 100% of the rated load amps for all other loads included in the circuit, per N.E.C. Article 430.24. If the optional Factory Mounted Control Transformer is provided, add the following MCA values to the electrical tables for the system providing power to the transformer: 17, add 2.5 amps; 28, add 2.3 amps; 40, add 1.5 amps, 46, add 1.3 amps; 58, add 1 amp.
2. The minimum recommended disconnect switch is based on 115% of the rated load amps for all loads included in the circuit, per N.E.C. Article 440.
3. Minimum fuse size is based upon 150% of the rated load amps for the largest motor plus 100% of the rated load amps for all other loads included in the circuit to avoid nuisance trips at startup due to lock rotor amps. It is not recommended in applications where brown outs, frequent starting and stopping of the unit, and/or operation at ambient temperatures in excess of 95°F (35°C) is anticipated.
4. Maximum fuse size is based upon 225% of the rated load amps for the largest motor plus 100% of the rated load amps for all other loads included in the circuit, per N.E.C. Article 440-22.
5. Circuit breakers must be UL listed and CSA certified and maximum size is based on 225% of the rated load amps for the largest motor plus 100% of the rated load amps for all other loads included in the circuit. Otherwise, an HACR type circuit breakers must be used. Maximum HACR circuit breaker rating is based on 225% of the rated load amps for the largest motor plus 100% of the rated load amps for all other loads included in the circuit.
6. The "INCOMING WIRE RANGE" is the minimum and maximum wire size that can be accommodated by the unit wiring lugs. The (2) preceding the wire range indicates the number of termination points available per phase of the wire range specified. Actual wire size and number of wires per phase must be determined based on the National Electrical Code, using copper connectors only. Field wiring must also comply with local codes.
7. A ground lug is provided for each compressor system to accommodate a field grounding conductor per N.E.C. Table 250.95. A control circuit grounding lug is also supplied.
8. The supplied disconnect is a "Disconnecting Means" as defined in the N.E.C. 100, and is intended for isolating the unit for the available power supply to perform maintenance and troubleshooting. This disconnect is not intended to be a Load Break Device.
9. Field Wiring by others which complies to the National Electrical Code & Local Codes.

UNIT VOLTAGE	UNIT VOLTAGE	CONTROL POWER	MCA NOTE A	OVER CURRENT PROTECTION, SEE NOTE B		NF DISC Sw
				MIN	MAX	
MODELS w/o CONTROL TRANS		115-1-60/50	15A	10A	15A	30 A / 240V
MODELS w/ CONTROL TRANS	-17	200-1-60	15A	10A	15A	30 A / 240V
	-28	230-1-60	15A	10A	15A	30 A / 240V
	-40	380-1-60	15A	10A	15A	30 A / 480V
	-46	460-1-60	15A	10A	15A	30 A / 480V
	-50	380/415-1-60	15A	10A	15A	30A / 415V
	-58	575-1-60	15A	10A	15A	30 A / 600V

A. Minimum #14 AWG, 75°C, Copper Recommended
 B. Minimum and Maximum Over Current Protection, Dual Element Fuse or Circuit Breaker

VOLTAGE RANGE			
VOLTAGE CODE	UNIT POWER	MIN.	MAX.
-17	200-3-60	180	220
-28	230-3-60	207	253
-40	380/415-3-60	342	440
-46	460-3-60	414	506
-50	380/415-3-50	342	440
-58	575-3-60	517	633

- LEGEND**
- ACR LINE ACROSS THE LINE START
 - C.B. CIRCUIT BREAKER
 - D.E. DUAL ELEMENT FUSE
 - DISC SW DISCONNECT SWITCH
 - FACT MOUNT CB FACTORY MOUNTED CIRCUIT BREAKER
 - FLA FULL LOAD AMPS
 - HZ HERTZ
 - MAX MAXIMUM
 - MCA MINIMUM CIRCUIT AMPACITY
 - MIN MINIMUM
 - MIN NF MINIMUM NON FUSED
 - RLA RATED LOAD AMPS
 - S.P. WIRE SINGLE POINT WIRING
 - UNIT MTD SERV SW UNIT MOUNTED SERVICE (NON-FUSED DISCONNECT SWITCH)
 - LRA LOCKED ROTOR AMPS

Electrical Data - 60Hz

YCAL0041 - YCAL0065

SINGLE POINT FIELD SUPPLIED POWER WIRING (See Fig. 2)

(One Field Provided Power Supply to the chiller. Field connections to Factory Provided Power Terminal Block (standard), Non-Fused Disconnect Switch (optional) or Circuit Breaker (optional).)

MODEL YCAL	VOLT	MCA ¹	MIN N/F DISC SW ²	D.E. FUSE		CKT. BKR. ⁵		FIELD WIRING LUGS ⁶ TERMINAL BLOCK (std)		FIELD WIRING LUGS ⁶ NF DISC. SWITCH (opt)	
				REC.	MAX ⁴	REC.	MAX	LUGS/ PHASE	LUG WIRE RANGE	LUGS/ PHASE	LUG WIRE RANGE
0041	200	197	250	225	225	225	225	1	6awg - 500MCM	1	6awg - 350MCM
	230	184	250	200	200	200	200	1	6awg - 500MCM	1	6awg - 350MCM
	380	107	150	125	125	125	125	1	6awg - 500MCM	1	6awg - 350MCM
	460	90	100	100	100	100	100	1	6awg - 500MCM	1	6awg - 350MCM
	575	71	100	80	80	80	80	1	6awg - 500MCM	1	6awg - 350MCM
0045	200	199	250	225	225	225	225	1	6awg - 500MCM	1	6awg - 350MCM
	230	186	250	200	200	200	200	1	6awg - 500MCM	1	6awg - 350MCM
	380	108	150	125	125	125	125	1	6awg - 500MCM	1	6awg - 350MCM
	460	91	100	100	100	100	100	1	6awg - 500MCM	1	6awg - 350MCM
	575	71	100	80	80	80	80	1	6awg - 500MCM	1	6awg - 350MCM
0051	200	228	250	250	250	250	250	1	6awg - 500MCM	2	3/0 - 250MCM
	230	212	250	225	250	225	250	1	6awg - 500MCM	2	3/0 - 250MCM
	380	123	150	150	150	150	150	1	6awg - 500MCM	1	6awg - 350MCM
	460	103	150	110	110	110	110	1	6awg - 500MCM	1	6awg - 350MCM
	575	81	100	90	90	90	90	1	6awg - 500MCM	1	6awg - 350MCM
0055	200	250	400	300	300	300	300	1	6awg - 500MCM	2	3/0 - 250MCM
	230	233	400	250	300	250	300	1	6awg - 500MCM	2	3/0 - 250MCM
	380	135	150	150	150	150	150	1	6awg - 500MCM	1	6awg - 350MCM
	460	113	150	125	125	125	125	1	6awg - 500MCM	1	6awg - 350MCM
	575	89	100	100	100	100	100	1	6awg - 500MCM	1	6awg - 350MCM
0061	200	274	400	300	300	300	300	1	6awg - 500MCM	1	250MCM - 500MCM
	230	255	400	300	300	300	300	1	6awg - 500MCM	1	250MCM - 500MCM
	380	148	200	175	175	175	175	1	6awg - 500MCM	1	6awg - 350MCM
	460	125	150	150	150	150	150	1	6awg - 500MCM	1	6awg - 350MCM
	575	98	150	110	110	110	110	1	6awg - 500MCM	1	6awg - 350MCM
0065	200	292	400	350	350	350	350	1	6awg - 500MCM	1	250MCM - 500MCM
	230	272	400	300	300	300	300	1	6awg - 500MCM	1	250MCM - 500MCM
	380	158	200	175	175	175	175	1	6awg - 500MCM	1	6awg - 350MCM
	460	132	150	150	150	150	150	1	6awg - 500MCM	1	6awg - 350MCM
	575	104	150	110	125	110	125	1	6awg - 500MCM	1	6awg - 350MCM

YCAL0041 - YCAL0065

SINGLE POINT FIELD SUPPLIED POWER WIRING (See Fig. 2)

(One Field Provided Power Supply to the chiller. Field connections to Factory Provided Power Terminal Block (standard), Non-Fused Disconnect Switch (optional) or Circuit Breaker (optional).)

FIELD WIRING LUGS ⁶ CIRCUIT BREAKER (opt)		SYSTEM #1 COMPRESSOR & FAN						SYSTEM #2 COMPRESSOR & FAN					
		COMPR. #1		COMPR. #2		FANS		COMPR. #1		COMPR. #2		FANS	
LUGS/ PHASE	LUG WIRE RANGE	RLA	LRA	RLA	LRA	QTY	FLA(EA)	RLA	LRA	RLA	LRA	QTY	FLA(EA)
1	6awg - 350MCM	39.1	250	39.1	250	2	7.6	39.1	250	39.1	250	2	7.6
1	6awg - 350MCM	36.2	250	36.2	250	2	7.4	36.2	250	36.2	250	2	7.4
1	6awg - 350MCM	20.9	155	20.9	155	2	4.5	20.9	155	20.9	155	2	4.5
1	6awg - 350MCM	17.2	125	17.2	125	2	4	17.2	125	17.2	125	2	4
1	6awg - 350MCM	13.8	100	13.8	100	2	2.9	13.8	100	13.8	100	2	2.9
1	6awg - 350MCM	40.0	250	40.0	250	2	7.6	39.1	250	39.1	250	2	7.6
1	6awg - 350MCM	37.0	250	37.0	250	2	7.4	36.2	250	36.2	250	2	7.4
1	6awg - 350MCM	21.3	155	21.3	155	2	4.5	20.9	155	20.9	155	2	4.5
1	6awg - 350MCM	17.6	125	17.6	125	2	4	17.2	125	17.2	125	2	4
1	6awg - 350MCM	14.1	100	14.1	100	2	2.9	13.8	100	13.8	100	2	2.9
2	3/0 - 250MCM	40.0	350	40.0	350	2	7.6	49.4	316	53.8	374	2	7.6
2	3/0 - 250MCM	37.0	350	37.0	350	2	7.4	45.8	316	49.8	374	2	7.4
1	6awg - 350MCM	21.3	195	21.3	195	2	4.5	26.4	199	28.7	235	2	4.5
1	6awg - 350MCM	17.6	167	17.6	167	2	4	21.8	158	23.7	187	2	4
1	6awg - 350MCM	14.1	125	14.1	125	2	2.9	17.4	126	19.0	150	2	2.9
2	3/0 - 250MCM	53.8	374	49.4	316	2	7.6	49.4	316	53.8	374	2	7.6
2	3/0 - 250MCM	49.8	374	45.8	316	2	7.4	45.8	316	49.8	374	2	7.4
1	6awg - 350MCM	28.7	235	26.4	199	2	4.5	26.4	199	28.7	235	2	4.5
1	6awg - 350MCM	23.7	187	21.8	158	2	4	21.8	158	23.7	187	2	4
1	6awg - 350MCM	19.0	150	17.4	126	2	2.9	17.4	126	19.0	150	2	2.9
1	250MCM - 500MCM	68.3	505	53.8	425	2	7.6	53.8	425	53.8	425	2	7.6
1	250MCM - 500MCM	63.3	505	49.8	425	2	7.4	49.8	425	49.8	425	2	7.4
1	6awg - 350MCM	36.5	280	28.7	239	2	4.5	28.7	239	28.7	239	2	4.5
1	6awg - 350MCM	30.1	225	23.7	198	2	4	23.7	198	23.7	198	2	4
1	6awg - 350MCM	24.1	180	19.0	148	2	2.9	19.0	148	19.0	148	2	2.9
1	250MCM - 500MCM	68.3	505	68.3	505	2	7.6	53.8	425	53.8	425	2	7.6
1	250MCM - 500MCM	63.3	505	63.3	505	2	7.4	49.8	425	49.8	425	2	7.4
1	6awg - 350MCM	36.5	280	36.5	280	2	4.5	28.7	239	28.7	239	2	4.5
1	6awg - 350MCM	30.1	225	30.1	225	2	4	23.7	198	23.7	198	2	4
1	6awg - 350MCM	24.1	180	24.1	180	2	2.9	19.0	148	19.0	148	2	2.9

Electrical Data - 50Hz

YCAL0041 - YCAL0065

SINGLE POINT FIELD SUPPLIED POWER WIRING (See Fig. 2)

(One Field Provided Power Supply to the chiller. Field connections to Factory Provided Power Terminal Block (standard), Non-Fused Disconnect Switch (optional) or Circuit Breaker (optional).)

MODEL YCAL	VOLT	MCA ¹	MIN N/F DISC SW ²	D.E. FUSE		CKT. BKR. ⁵		FIELD WIRING LUGS ⁶		FIELD WIRING LUGS ⁶	
				REC.	MAX ⁴	REC.	MAX	TERMINAL BLOCK (std)		NF DISC. SWITCH (opt)	
								LUGS/ PHASE	LUG WIRE RANGE	LUGS/ PHASE	LUG WIRE RANGE
0041	380/415	90	100	100	100	100	100	1	6awg - 500MCM	1	6awg - 350MCM
0045	380/415	91	100	100	100	100	100	1	6awg - 500MCM	1	6awg - 350MCM
0051	380/415	103	150	110	110	110	110	1	6awg - 500MCM	1	6awg - 350MCM
0055	380/415	113	150	125	125	125	125	1	6awg - 500MCM	1	6awg - 350MCM
0061	380/415	124	150	150	150	150	150	1	6awg - 500MCM	1	6awg - 350MCM
0065	380/415	132	150	150	150	150	150	1	6awg - 500MCM	1	6awg - 350MCM

Preliminary

YCAL0041 - YCAL0065

SINGLE POINT FIELD SUPPLIED POWER WIRING (See Fig. 2)

(One Field Provided Power Supply to the chiller. Field connections to Factory Provided Power Terminal Block (standard), Non-Fused Disconnect Switch (optional) or Circuit Breaker (optional).)

FIELD WIRING LUGS ⁶		SYSTEM #1 COMPRESSOR & FAN						SYSTEM #2 COMPRESSOR & FAN					
CIRCUIT BREAKER (opt)		COMPR. #1		COMPR. #2		FANS		COMPR. #1		COMPR. #2		FANS	
LUGS/ PHASE	LUG WIRE RANGE	RLA	LRA	RLA	LRA	QTY	FLA (EA)	RLA	LRA	RLA	LRA	QTY	FLA (EA)
1	6awg - 350MCM	17.2	125	17.2	125	2	4	17.2	125	17.2	125	2	4
1	6awg - 350MCM	17.6	125	17.6	125	2	4	17.2	125	17.2	125	2	4
1	6awg - 350MCM	17.6	158	17.6	158	2	4	21.8	127	23.7	187	2	4
1	6awg - 350MCM	23.7	187	21.8	127	2	4	21.8	127	23.7	187	2	4
1	6awg - 350MCM	30.1	225	23.7	198	2	4	23.7	167	23.7	167	2	4
1	6awg - 350MCM	30.1	225	30.1	225	2	4	23.7	198	23.7	198	2	4

Preliminary

035-20880-103
REV. R
ELEMENTARY DIAGRAM
STANDARD AND REMOTE EVAPORATOR UNITS

- NOTES:
- FIELD WIRING TO BE IN ACCORDANCE WITH THE CURRENT EDITION OF THE NATIONAL ELECTRICAL CODE (NEC).
 - APPLICABLE CODES AND SPECIFICATIONS SHALL BE OBSERVED. WIRING SHALL NOT BE MADE IN THE SAME CONDUIT WITH ANY LINE VOLTAGE (CLASS I) WIRING.
 - WIRING SHALL BE MADE IN ACCORDANCE WITH THE CURRENT EDITION OF THE NATIONAL ELECTRICAL CODE (NEC).
 - TO STOP UNIT (EMERGENCY STOP) WITH CONTACTS OTHER THAN THOSE SHOWN, A STOP SWITCH MUST BE INSTALLED. A JUMPER MUST BE CONNECTED BETWEEN TERMINALS 5 AND 6.
 - CONTACTS ARE RATED AT 125% (O.C.A.) RESISTIVE LOAD ONLY, AND MUST BE USED WITH A PROTECTIVE DEVICE.
 - SEE INSTALLATION, OPERATION AND MAINTENANCE MANUAL WHEN APPLICABLE.
 - OPTIONAL CURRENT READOUT, SY # 1, 225A.
 - MP THRU MP ARE CONTAINED IN THEIR RESPECTIVE COMPRESSOR JUNCTION BOXES.
- LEGEND
- TS TRANSIENT VOLTAGE SUPPRESSION
 - △ LEAKAGE CURRENT DETECTOR (SEE NOTE 2)
 - LEAKAGE CURRENT DETECTOR (SEE NOTE 2)
 - WIRING AND COMPONENTS BY YORK
 - WIRING AND COMPONENTS BY OTHERS

DETAIL "A"

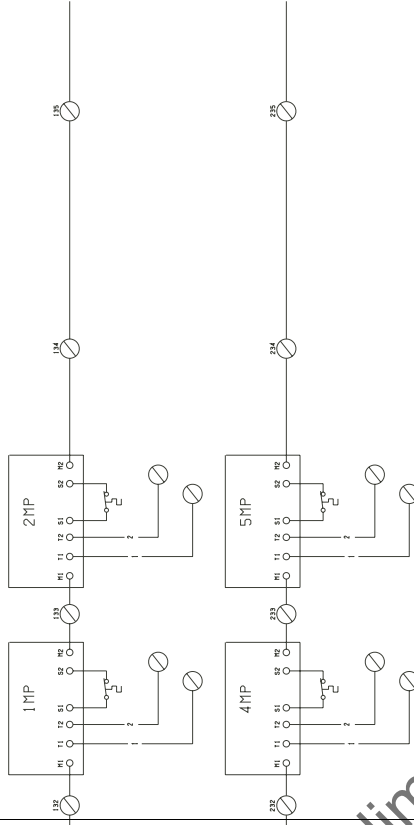

DETAIL "B" TYPICAL FOR INTERNALLY PROTECTED MOTORS

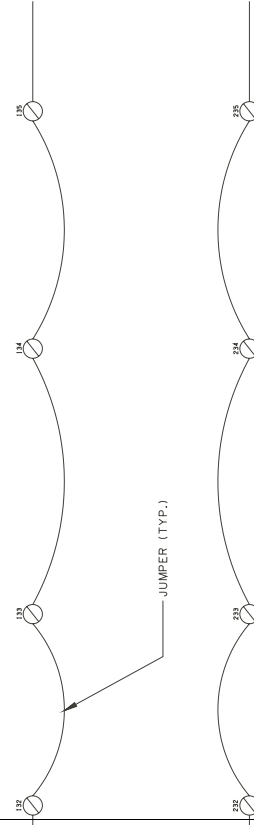

DETAIL "C"



CONNECTION DIAGRAM

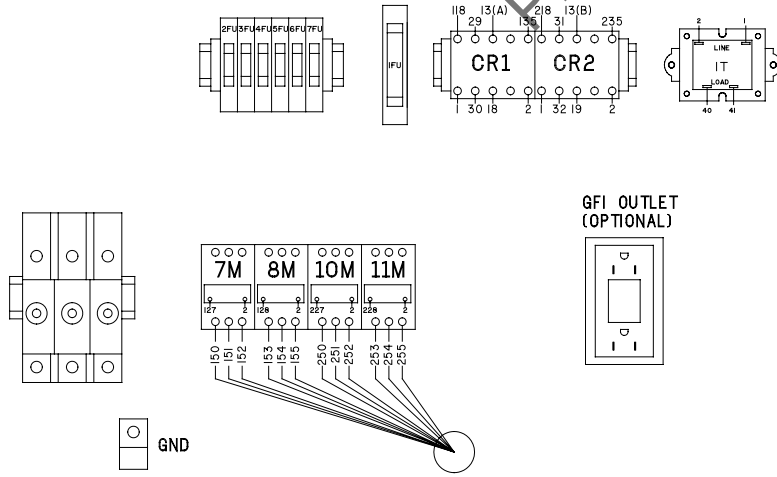

TEMP. RESET OPTION OR GATEWAY OPTION LOCATION (SEE 035-20880-105)

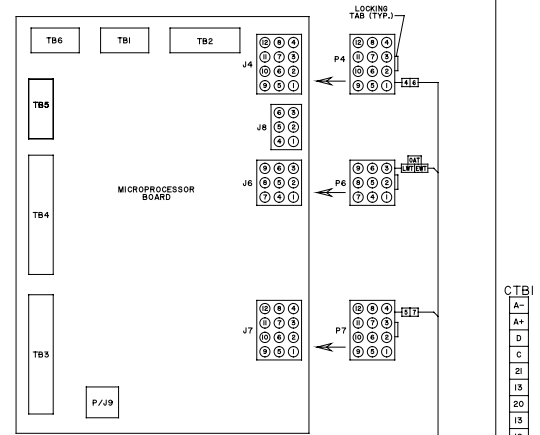

TB1	
124	125
131	132
133	134
135	136
137	138
139	140
141	142
143	144
145	146
147	148
149	150
151	152
153	154
155	156
157	158
159	160
161	162
163	164
165	166
167	168
169	170
171	172
173	174
175	176
177	178
179	180
181	182
183	184
185	186
187	188
189	190
191	192
193	194
195	196
197	198
199	200
201	202
203	204
205	206
207	208
209	210
211	212
213	214
215	216
217	218
219	220
221	222
223	224
225	226
227	228
229	230
231	232
233	234
235	236
237	238
239	240
241	242
243	244
245	246
247	248
249	250
251	252
253	254
255	256
257	258
259	260
261	262
263	264
265	266
267	268
269	270
271	272
273	274
275	276
277	278
279	280
281	282
283	284
285	286
287	288
289	290
291	292
293	294
295	296
297	298
299	300
301	302
303	304
305	306
307	308
309	310
311	312
313	314
315	316
317	318
319	320
321	322
323	324
325	326
327	328
329	330
331	332
333	334
335	336
337	338
339	340
341	342
343	344
345	346
347	348
349	350
351	352
353	354
355	356
357	358
359	360
361	362
363	364
365	366
367	368
369	370
371	372
373	374
375	376
377	378
379	380
381	382
383	384
385	386
387	388
389	390
391	392
393	394
395	396
397	398
399	400

INSIDE BOTTOM OF ENCLOSURE

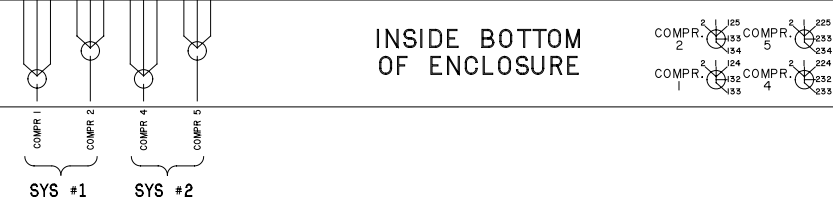

OPTION CONNECTION DIAGRAM
MICROBOARD (PARTIAL)

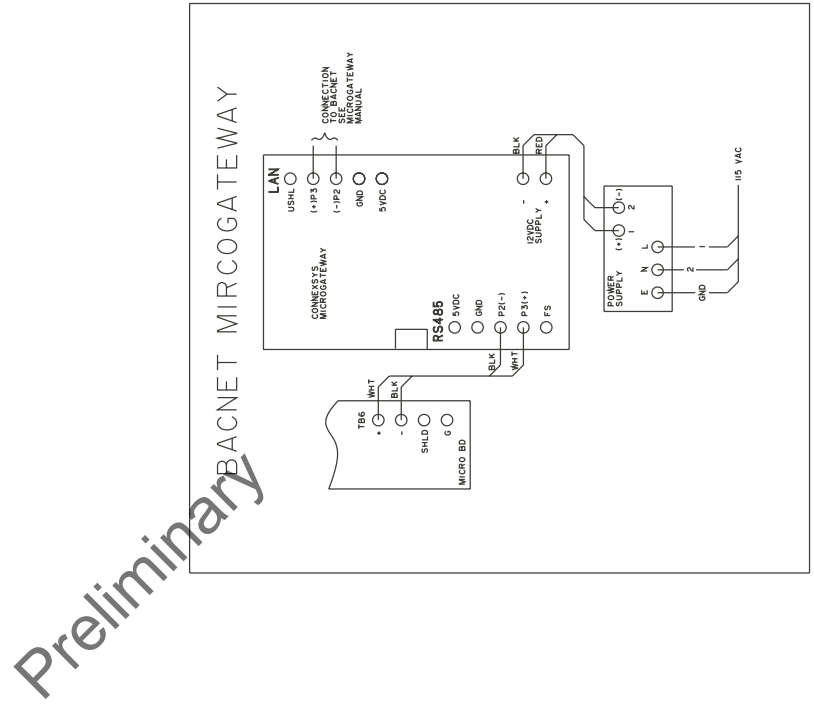
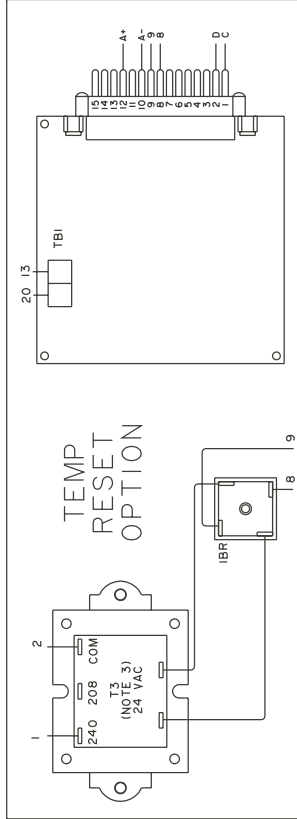

Control Wiring

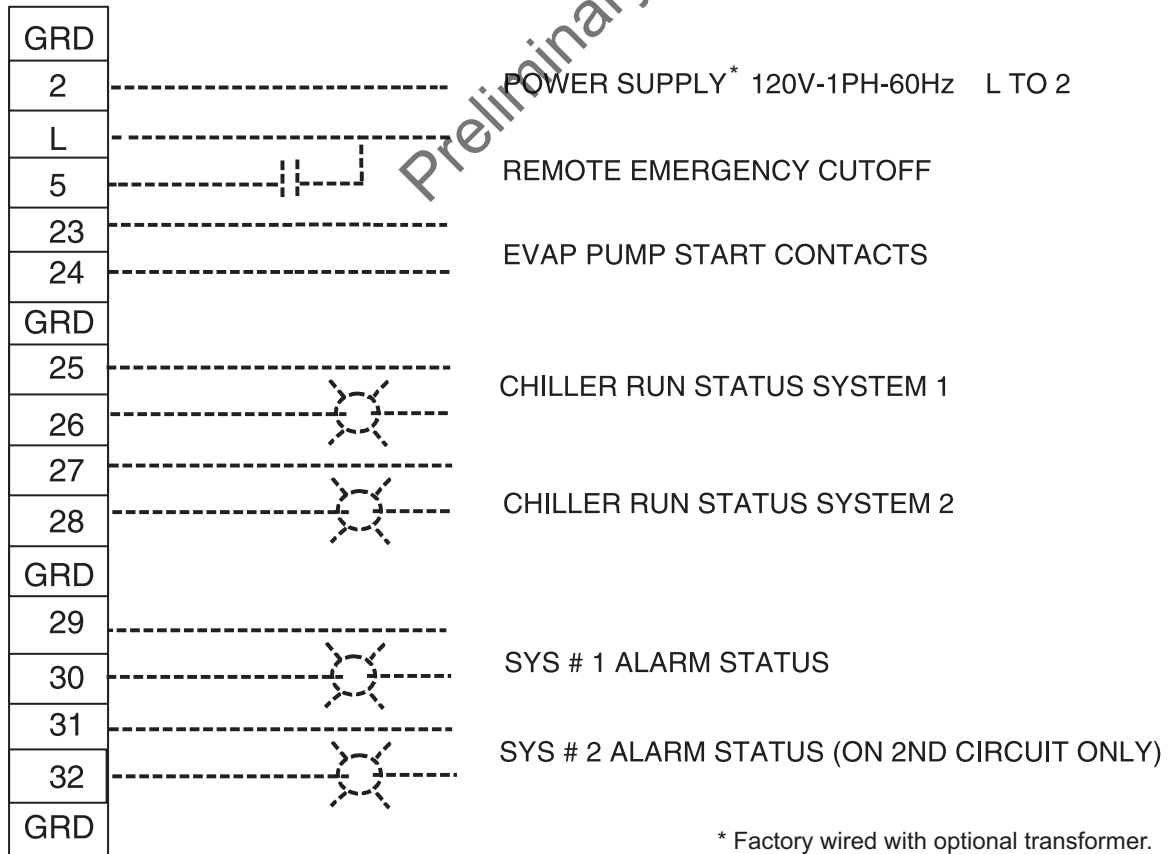
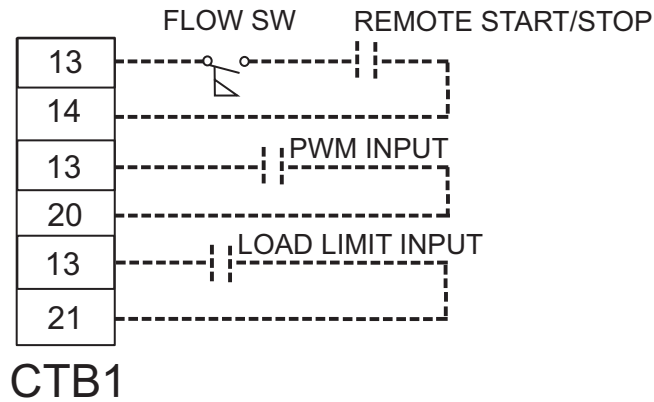

CTB2

LD03611

Application Data

UNIT LOCATION

The YCAL chillers are designed for outdoor installation. When selecting a site for installation, be guided by the following conditions:

1. For outdoor locations of the unit, select a place having an adequate supply of fresh air for the condenser.
2. Avoid locations beneath windows or between structures where normal operating sounds may be objectionable.
3. Installation sites may be either on a roof, or at ground level. (See FOUNDATION.)
4. The condenser fans are the propeller-type, and are not recommended for use with duct work in the condenser air stream.
5. When it is desirable to surround the unit(s), it is recommended that the screening be able to pass the required chiller CFM without exceeding 0.1" of water external static pressure.
6. Protection against corrosive environments is available by supplying the units with either copper fin, cured epoxy-dipped, or epoxy-coated fins on the condenser coils. The epoxy-dipped or epoxy-coated coils should be offered with any units being installed at the seashore or where salt spray may hit the unit.

In installations where winter operation is intended and snow accumulations are expected, additional height must be provided to ensure normal condenser air flow.

Recommended clearances for units are given in DIMENSIONS. When the available space is less, the unit(s) must be equipped with the discharge pressure transducer option to permit high pressure unloading in the event that air recirculation were to occur.

FOUNDATION

The unit should be mounted on a flat and level foundation, ground or roof, capable of supporting the entire operating weight of the equipment. Operating weights are given in the PHYSICAL DATA tables.

ROOF LOCATIONS – Choose a spot with adequate structural strength to safely support the entire weight of the unit and service personnel. Care must be taken not to damage the roof during installation. If the roof is "bonded", consult the building contractor or architect

for special installation requirements. Roof installations should incorporate the use of spring-type isolators to minimize the transmission of vibration into the building structure.

GROUND LEVEL INSTALLATIONS – It is important that the units be installed on a substantial base that will not settle, causing strain on the liquid lines and resulting in possible leaks. A one-piece concrete slab with footers extending below the frost line is highly recommended. Additionally, the slab should not be tied to the main building foundation, as noises will telegraph.

Mounting holes (11/16" diameter) are provided in the steel channel for bolting the unit to its foundation. See DIMENSIONS.

For ground level installations, precautions should be taken to protect the unit from tampering by or injury to unauthorized persons. Screws on access panels will prevent casual tampering; however, further safety precautions, such as unit enclosure options, a fenced-in enclosure, or locking devices on the panels may be advisable. Check local authorities for safety regulations.

CHILLED LIQUID PIPING

The chilled liquid piping system should be laid out so that the circulating pump discharges into the cooler. The inlet and outlet cooler liquid connections are given in DIMENSIONS.

Hand stop valves are recommended for use in all lines to facilitate servicing. Drain connections should be provided at all low points to permit complete drainage of the cooler and system piping. Additionally, a strainer (40 mesh) is recommended for use on the INLET line to the cooler.

Pressure gauge connections are recommended for installation in the inlet and outlet water lines. Gauges are not furnished with the unit and are to be furnished by other suppliers.

The chilled liquid lines that are exposed to outdoor ambients should be wrapped with a supplemental heater cable and covered with insulation. As an alternative, ethylene glycol should be added to protect against freezeup during low ambient periods.

A flow switch is available as an accessory on all units. The flow switch (or its equivalent) must be installed in the leaving water piping of the cooler and must not be

Typical Piping for Brazed-Plate Coolers

Notes:

- 1. Placement on a level surface free of obstructions (including snow, for winter operation) or air recirculation ensures rated performance, reliable operation and ease of maintenance.
- 2. Piping and wiring shown is for reference use only and is not in accordance with any national or local standards.
- 3. All wiring and piping must comply with applicable local and national codes.
- 4. All wiring and piping must follow standard piping techniques as discussed in the ASHRAE handbook.
- 5. A strainer with a mesh size between .5 and 1.5 mm is recommended upstream of the heat exchanger to prevent clogging.

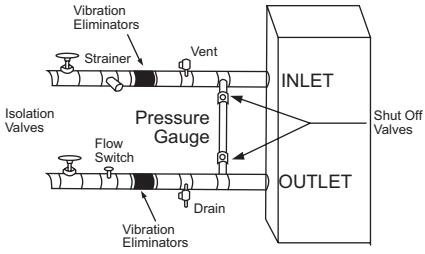
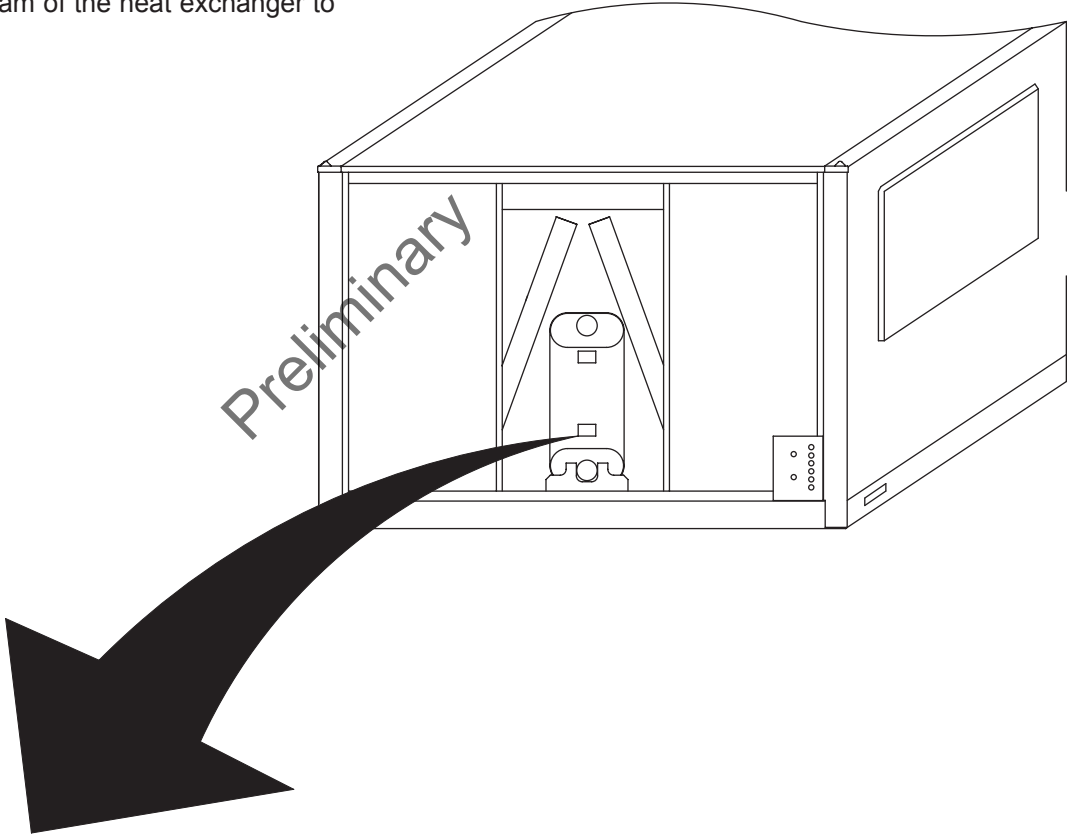

Guide Specifications

PART 1 – GENERAL

1.01 SCOPE

- A. The requirements of the General Conditions, Supplementary Conditions, Division 1, and Drawings apply to all Work herein.
- B. Provide Microprocessor controlled, multiple-scroll compressor, air-cooled, liquid chillers of the scheduled capacities as shown and indicated on the Drawings, including but not limited to:
 - 1. Chiller package
 - 2. Electrical power and control connections
 - 3. Chilled water connections
 - 4. Change of refrigerant oil (for factory mounted evaporator) or (evaporator shipped separately for field installation and piping by contractor)

1.02 QUALITY ASSURANCE

- A. Products shall be Designed, Tested, Rated and Certified in accordance with, and installed in compliance with applicable sections of the following Standards and Codes:
 - 1. ANSI/ASHRAE Standard 15 – *Safety Code for Mechanical Refrigeration*
 - 2. ASHRAE 90.1– *Energy Efficiency compliance*.
 - 3. ANSI/NFPA Standard 70 – *National Electrical Code (N.E.C.)*.
 - 4. *ASME Boiler & Pressure Vessel Code, Section VIII, Division 1*.
 - 5. ARI Standard 550/590 – *Positive Displacement Compressors and Air Cooled Rotary Screw Water-Chilling Packages*.
 - 6. Conform to Intertek Testing Services, formerly ETL, for construction of chillers and provide ETL/cETL Listing label.
 - 7. Manufactured in facility registered to ISO 9002.
 - 8. OSHA - Occupational Safety and Health Act
- B. Factory Test: Chiller shall be pressure-tested, evacuated and fully charged with refrigerant and oil, and shall be factory operational run tested with water flowing through the vessel.
- C. Chiller manufacturer shall have a factory trained and supported service organization that is within a 50 mile radius of the site.
- D. Warranty: Manufacturer shall Warrant all equipment and material of its manufacture against defects in

workmanship and material for a period of one year from date of initial start-up or eighteen (18) months from date of shipment, whichever occurs first.

1.03 DELIVERY AND HANDLING

- A. Unit shall be delivered to job site fully assembled, and charged with refrigerant and oil by the Manufacturer. (Contractor is responsible for providing and installing the refrigerant charge including the charge required for the field installed interconnecting piping. Chiller components shall ship with a dry nitrogen holding charge – Remote Evaporator option).
- B. Unit shall be stored and handled per Manufacturer's instructions.

PART 2 - PRODUCTS

2.01 CHILLER MATERIALS AND COMPONENTS

- A. General: Install and commission, as shown on the schedules and plans, factory assembled, charged, and tested air cooled scroll compressor chiller(s) as specified herein. Chiller shall be designed, selected, and constructed using a refrigerant with Flammability rating of "1", as defined by ANSI/ASHRAE STANDARD - 34 *Number Designation and Safety Classification of Refrigerants*. Chiller shall include, but is not limited to: a complete system with a single refrigerant circuit 35 tons (123kW) and below, and not less than two refrigerant circuits above 35 tons (123kW), scroll compressors, direct expansion type evaporator, air-cooled condenser, refrigerant, lubrication system, interconnecting wiring, safety and operating controls including capacity controller, control center, motor starting components, and special features as specified herein or required for safe, automatic operation.
- B. Cabinet: External structural members shall be constructed of heavy gauge, galvanized steel coated with baked on powder paint which, when subject to ASTM B117, 1000 hour, 5% salt spray test, yields minimum ASTM 1654 rating of "6". Add Wire Panels of heavy gauge, welded wire-mesh, coated to resist corrosion, to protect condenser coils from incidental damage and restrict unauthorized access to internal components. Factory installed.

2.02 COMPRESSORS

Compressors: Shall be hermetic, scroll-type, including:

1. Compliant design for axial and radial sealing
2. Refrigerant flow through the compressor with 100% suction cooled motor.
3. Large suction side free volume and oil sump to provide liquid handling capability.
4. Compressor crankcase heaters to provide extra liquid migration protection.
5. Annular discharge check valve and reverse vent assembly to provide low pressure drop, silent shut-down and reverse rotation protection.
6. Initial Oil charge.
7. Oil Level sightglass.
8. Vibration isolator mounts for compressors.
9. Brazed-type connections for fully hermetic refrigerant circuits.

2.03 REFRIGERANT CIRCUIT COMPONENTS

Each refrigerant circuit shall include: liquid line shutoff valve with charging port, low side pressure relief device, filter-drier, solenoid valve, sight glass with moisture indicator, expansion valves, and flexible, closed-cell foam insulated suction line.

2.04 HEAT EXCHANGERS

A. Evaporator:

1. Evaporator shall be brazed-plate stainless steel construction, single or dual circuit heat exchangers capable of refrigerant working pressure of 450 psig (3103 kPa) and liquid side pressure of 150 psig (1034 kPa) (Option for 300 psig [2068 kPa] available.)
2. Evaporator shall be covered in 3/4" (19mm) flexible, closed cell insulation, thermal conductivity of 0.26k (BTU/HR-FT²-°F)/in.) maximum.
3. Cooler shall have thermostatically controlled heaters to protect to -20°F (29°C) ambient in off-cycle.
4. Brazed plate heat exchangers shall be UL listed.
5. Installing contractor must include accommodations in the chilled water piping to allow proper drainage and venting of the heat exchanger. A strainer with a mesh size between 0.5 and 1.5mm (40 mesh) is recommended upstream of the heat exchanger to prevent clogging.

B. Air Cooled Condenser:

1. Coils: Internally enhanced, seamless copper tubes, mechanically expanded into aluminum alloy fins with full height collars. Subcooling coil an integral part of condenser. Design working pressure shall be 450 PSIG (31 bar).

2. Low Noise Fans: Shall be dynamically and statically balanced, direct drive, corrosion resistant glass fiber reinforced composite blades molded into a low noise, full-airfoil cross section, providing vertical air discharge and low sound. Each fan in its own compartment to prevent crossflow during fan cycling. Guards of heavy gauge, PVC (polyvinylchloride) coated or galvanized steel.
3. Fan Motors: High efficiency, direct drive, 6 pole, 3 phase, insulation class "F", current protected, Totally Enclosed Air-Over (TEAO), rigid mounted, with double sealed, permanently lubricated, ball bearings.

2.05 CONTROLS

- A. General: Automatic start, stop, operating, and protection sequences across the range of scheduled conditions and transients.
- B. Microprocessor Enclosure: Rain and dust tight NEMA 3R/12 (IP55) powder painted steel cabinet with hinged, latched, and gasket sealed door.
- C. Microprocessor Control Center:
 1. Automatic control of compressor start/stop, anti-coincidence and anti-recycle timers, automatic pumpdown on shutdown, condenser fans, evaporator pump, evaporator heater, unit alarm contacts, and chiller operation from 0°F to 125°F (-18°C to 52°C) ambient. Automatic reset to normal chiller operation after power failure.
 2. Remote water temperature reset via a Pulse Width Modulated (PWM) input signal or up to two steps of demand (load) limiting.
 3. Software stored in non-volatile memory, with programmed setpoints retained in lithium battery backed real time clock (RTC) memory for minimum 5 years.
 4. Forty character liquid crystal display, descriptions in English (or Spanish, French, Italian, or German), numeric data in English (or Metric) units. Sealed keypad with sections for Setpoints, Display/Print, Entry, Unit Options & clock, and On/Off Switch.
 5. Programmable Setpoints (within Manufacturer limits): display language; chilled liquid temperature setpoint and range, remote reset temperature range, set daily schedule/holiday for start/stop, manual override for servicing, low and high ambient cutouts, number of compressors, low liquid temperature cutout, low suction pressure

cutout, high discharge pressure cutout, anti-recycle timer (compressor start cycle time), and anti-coincident timer (delay compressor starts).

6. Display Data: Return and leaving liquid temperatures, low leaving liquid temperature cut-out setting, low ambient temperature cutout setting, outdoor air temperature, English or metric data, suction pressure cutout setting, each system suction pressure, discharge pressure (standard on YCAL0041-0065 models), liquid temperature reset via a YORK ISN DDC or Building Automation System (by others) via PWM input as standard or a 4-20milliamp or 0-10 VDC input or contact closure with optional BAS interface, anti-recycle timer status for each compressor, anti-coincident system start timer condition, compressor run status, no cooling load condition, day, date and time, daily start/stop times, holiday status, automatic or manual system lead/lag control, lead system definition, compressor starts/operating hours (each), status of hot gas valves, evaporator heater and fan operation, run permissive status, number of compressors running, liquid solenoid valve status, load & unload timer status, water pump status.

7. System Safeties: Shall cause individual compressor systems to perform auto shut down; manual reset required after the third trip in 90 minutes. Includes: high discharge pressure, low suction pressure, high pressure switch, and motor protector. Compressor motor protector shall protect against damage due to high input current or thermal overload of windings.

8. Unit Safeties: Shall be automatic reset and cause compressors to shut down if low ambient, low leaving chilled liquid temperature, under voltage, and flow switch operation. Contractor shall provide flow switch and wiring per chiller manufacturer requirements.

9. Alarm Contacts: Low ambient, low leaving chilled liquid temperature, low voltage, low battery, and (per compressor circuit): high discharge pressure, and low suction pressure.

- D. Manufacturer shall provide any controls not listed above, necessary for automatic chiller operation. Mechanical Contractor shall provide field control wiring necessary to interface sensors to the chiller control system.

A. Power Panels:

1. NEMA 3R/12 (IP55) rain/dust tight, powder painted steel cabinets with hinged, latched, and gasket sealed outer doors. Provide main power connection(s), control power connections, compressor and fan motor start contactors, current overloads, and factory wiring.
2. Power supply shall enter unit at a single location, be 3 phase of scheduled voltage, and connect to individual terminal blocks per compressor. Separate disconnecting means and/or external branch circuit protection (by Contractor) required per applicable local or national codes.

- B. Exposed compressor, control and fan motor power wiring shall be routed through liquid tight conduit.

2.07 ACCESSORIES AND OPTIONS

Some accessories and options supercede standard product features. Your YORK representative will be pleased to provide assistance.

- A. Microprocessor controlled, Factory installed Across-the-Line type compressor motor starters as standard.

B. Outdoor Ambient Temperature Control

1. Low Ambient Control: Permits unit operation to 0°F ambient.
2. High Ambient Control: Permits unit operation above 115°F ambient.

C. Power Supply Connections:

1. Single Point Power Supply: Single point Terminal Block for field connection and interconnecting wiring to the compressors. Separate external protection must be supplied, by others, in the incoming power wiring, which must comply with the National Electric Code and/or local codes. Standard unit controls to 25°F ambient. Low Ambient Control standard on YCAL0041-0065 models
2. Single Point Power Supply with individual System Breakers: Single or Terminal Block(s) for field connection and factory interconnecting wiring to factory supplied system breakers. Available on YCAL0090-0134 models.
3. Single Point or Disconnect: Single or Dual point Non-Fused Disconnect(s) and lockable external handle (in compliance with Article 440-14

2.06 POWER CONNECTION AND DISTRIBUTION

of N.E.C.) can be supplied to isolate the unit power voltage for servicing. Separate external fusing must be supplied, by others, in the incoming power wiring, which must comply with the National Electric Code and/or local codes.

4. Single Point Disconnect with Individual System Breakers: Single point Terminal Block with Non-Fused Disconnect and lockable external handle (in compliance with Article 440-14 of N.E.C.) can be supplied to isolate power voltage for servicing. Factory interconnecting wiring from disconnect to factory supplied circuit breakers. Available on YCAL0041-0065.
5. Single Point Circuit Breaker: Single point Terminal Block with Circuit Breaker and lockable external handle (in compliance with Article 440 14 of N.E.C.) can be supplied to isolate power voltage for servicing. Incoming power wiring must comply with the National Electric Code and/or local codes. Single Point Circuit Breakers available on YCAL0041-0065 models.

D. Pressure Transducers and Readout Capability

1. Discharge Pressure Transducers: Permits unit to sense and display discharge pressure. Standard on YCAL0080-0134 models.

E. Control Power Transformer: Converts unit power voltage to 120-1-60 (500 VA capacity). Factory-mounting includes primary and secondary wiring between the transformer and the control panel.

F. Motor Current Module: Capable of monitoring compressor motor current. Provides extra protection against compressor reverse rotation, phase-loss and phase imbalance. Option consists of one module per electrical system. (Factory-mounted.)

G. Power Factor Correction Capacitors: Provided to correct unit compressor factors to a 0.90-0.95.

H. Condenser Coil Environmental Protection:

1. Pre-Coated: Epoxy coated aluminum fin stock to guard from corrosive agents and insulate against galvanic potential. For mild seashore or industrial locations.
2. Copper Fin: Provide copper fins in lieu of aluminum.
3. Post-Coated Dipped: Dipped-cured coating on condenser coils for seashore and other corrosive applications (with the exception of strong alkalis, oxidizers, and wet bromine, chlorine and fluorine in concentrations greater than

100ppm).

- I. Protective Chiller Panels (Factory or Field Mounted)
 1. Louvered Panels (condenser coils only): Painted steel as per remainder of unit cabinet, over external condenser coil faces.
 2. Wire Panels (full unit): Heavy gauge, welded wire-mesh, PVC-coated to resist corrosion, to protect condenser coils from incidental damage and restrict unauthorized access to internal components.
 3. Louvered Panels (full unit): Painted steel as per remainder of unit cabinet, to protect condenser coils from incidental damage, visually screen internal components, and prevent unauthorized access to internal components.
 4. Louvered/Wire Panels: Louvered steel panels on external condenser coil faces, painted as per remainder of unit cabinet. Heavy gauge, welded wire-mesh, coated to resist corrosion, around base of machine to restrict unauthorized access.

Flow Switch (Field-mounted): Vapor proof SPDT, NEMA 4X switch (___ 150 PSIG or ___ 300 PSIG), -20°F to 250°F.

K. Differential Pressure Switch: Alternative to an above mentioned flow switch. Pretempco model DPS300A-P40PF-82582-5 (300 psi max. working pressure) SPDT 5 amp 125/250VAC switch, Range 0 - 40 PSID, deadband 0.5 - 0.8 psi, with 1/4" NPTE Pressure Connections.

L. Evaporator options:

1. Provide 1 1/2" cooler insulation in lieu of standard 3/4".
2. Provide DX Cooler with 300 PSIG water-side design working pressure in lieu of standard 150 PSIG.
3. Provide Raised Face Flanges for field installation on cooler nozzles and field piping:
 - a. 150 PSIG, welded Flanges.
 - b. 300 PSIG, welded Flanges.

M. Service Isolation valves: Service suction and discharge (ball type) isolation valves are added to unit per system. This option also includes a system high pressure relief valve in compliance with ASHRAE 15. (Factory-mounted.)

N. Remote Cooler: Manufacturer shall provide separately: chiller less evaporator, leaving and return

water sensors, and liquid line components (solenoid valves, filter driers, sight glasses, and TXVs), as discrete elements of a complete factory system. Contractor shall be field erect system and provide interconnecting refrigerant piping and wiring in accordance with Manufacturer recommendations, and project plans and schedules. Where not otherwise specified, Contractor provided system piping shall be in accordance with applicable sections of ASHRAE Handbook.

- O. Hot Gas By-Pass: Permits continuous, stable operation at capacities below the minimum step of unloading to as low as 5% capacity (depending on both the unit & operating conditions) by introducing an artificial load on the cooler. Hot gas by-pass is installed on only one refrigerant circuit (System #1).
- P. Microprocessor Membrane Keypad Graphics on in lieu of Standard English:
 - 1. French language.
 - 2. German language.
 - 3. Spanish language.
 - 4. Italian language.
- Q. Thermal Storage: Leaving chilled liquid setpoint range for charge cycle from 25°F to 20°F minimum, with automatic reset of the leaving brine temperature up to 40°F above the setpoint. (Works with Option T)
- R. Low Temperature Process Brine: Leaving chilled liquid setpoint range 20°F to 30°F.
- S. Chicago Code Relief Valves to meet Chicago Code requirements.
- T. Building Automation System (EMS) Reset Interface: Chiller to accept 4 to 20mA, 0 to 10 VDC, or discrete contact closure input to reset the leaving chilled liquid temperature.
- U. Remote Control Panel (Field-mounted): Auxiliary panel for remote user interface for functions normally made at the unit control center. Available on YCAL0014-0080 models.
- V. OptiView Remote Control Panel (Field-mounted): Graphical interface panel to remotely control and monitor up to 8 different units.
- W. Multi-Unit Sequencing Panel (Field-mounted): Separate Sequencing control center is provided to permit control of up to eight chillers in parallel based

on mixed liquid temperature.

- X. Sound Reduction (Factory-mounted):
 - 1. Ultra quiet, low speed, reduced noise fans
 - 2. Compressor Acoustic Sound Blankets
- Y. Vibration Isolation (Field-mounted):
 - 1. Neoprene Pad Isolators.
 - 2. 1 Inch Deflection Spring Isolators: Level adjustable, spring and cage type isolators for mounting under the unit base rails.
 - 3. 2 Inch Deflection Seismic Isolators: Level adjustable, restrained mounts in rugged welded steel housing with vertical and horizontal limit stops. Housings shall be designed to withstand a minimum 1.0g accelerated force in all directions to 2 inches.

PART 3 - EXECUTION

3.01 INSTALLATION

- A. General: Rig and Install in full accordance with Manufacturers requirements, Project drawings, and Contract documents.
- B. Location: Locate chiller as indicated on drawings, including cleaning and service maintenance clearance per Manufacturer instructions. Adjust and level chiller on support structure. If equipment provided exceeds height of scheduled chiller, installing contractor is responsible for additional costs associated with extending the height of parapet or screening walls/enclosures
- C. Components: Installing Contractor shall provide and install all auxiliary devices and accessories for fully operational chiller.
- D. Electrical: Coordinate electrical requirements and connections for all power feeds with Electrical Contractor (Division 16).
- E. Controls: Coordinate all control requirements and connections with Controls Contractor.
- F. Finish: Installing Contractor shall paint damaged and abraded factory finish with touch-up paint matching factory finish.

Preliminary



Preliminary

Preliminary

Preliminary



P. O. Box 1592, York, Pennsylvania USA 17504-1592
© by Johnson Controls 2006

Tele. 800-861-1001
www.york.com

Subject to change without notice. Printed in USA
ALL RIGHTS RESERVED

Form 150.64-EG1 (106)
Supersedes: 150.64-EG1 (102)

RPC 3M 303 9.28
Codes: DXL, ET2