



YORK® CUSTOM™ AIR HANDLING UNITS

INSTALLATION AND ASSEMBLY

New Release

Form 102.20-N3 (615)



LD13282

YORK® CUSTOM™ AHU

Issue Date:
June 1, 2015

IMPORTANT!

READ BEFORE PROCEEDING!

GENERAL SAFETY GUIDELINES

This equipment is a relatively complicated apparatus. During rigging, installation, operation, maintenance, or service, individuals may be exposed to certain components or conditions including, but not limited to: heavy objects, refrigerants, materials under pressure, rotating components, and both high and low voltage. Each of these items has the potential, if misused or handled improperly, to cause bodily injury or death. It is the obligation and responsibility of rigging, installation, and operating/service personnel to identify and recognize these inherent hazards, protect themselves, and proceed safely in completing their tasks. Failure to comply with any of these requirements could result in serious damage to the equipment and the property in

which it is situated, as well as severe personal injury or death to themselves and people at the site.

This document is intended for use by owner-authorized rigging, installation, and operating/service personnel. It is expected that these individuals possess independent training that will enable them to perform their assigned tasks properly and safely. It is essential that, prior to performing any task on this equipment, this individual shall have read and understood the on-product labels, this document, and any referenced materials. This individual shall also be familiar with and comply with all applicable industry and governmental standards and regulations pertaining to the task in question.

SAFETY SYMBOLS

The following symbols are used in this document to alert the reader to specific situations:



Indicates a possible hazardous situation which will result in death or serious injury if proper care is not taken.

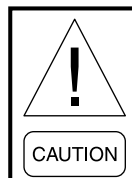

Identifies a hazard which could lead to damage to the machine, damage to other equipment and/or environmental pollution if proper care is not taken or instructions are not followed.



Indicates a potentially hazardous situation which will result in possible injuries or damage to equipment if proper care is not taken.

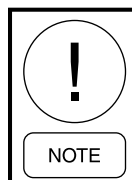

Highlights additional information useful to the technician in completing the work being performed properly.



External wiring, unless specified as an optional connection in the manufacturer's product line, is not to be connected inside the control cabinet. Devices such as relays, switches, transducers and controls and any external wiring must not be installed inside the micro panel. All wiring must be in accordance with Johnson Controls' published specifications and must be performed only by a qualified electrician. Johnson Controls will NOT be responsible for damage/problems resulting from improper connections to the controls or application of improper control signals. Failure to follow this warning will void the manufacturer's warranty and cause serious damage to property or personal injury.

CHANGEABILITY OF THIS DOCUMENT

In complying with Johnson Controls' policy for continuous product improvement, the information contained in this document is subject to change without notice. Johnson Controls makes no commitment to update or provide current information automatically to the manual or product owner. Updated manuals, if applicable, can be obtained by contacting the nearest Johnson Controls Service office or accessing the Johnson Controls QuickLIT website at <http://cgproducts.johnsoncontrols.com>.

It is the responsibility of rigging, installation, and operating/service personnel to verify the applicability of these documents to the equipment. If there is any ques-

tion regarding the applicability of these documents, rigging, lifting, and operating/service personnel should verify whether the equipment has been modified and if current literature is available from the owner of the equipment prior to performing any work on the unit.

CHANGE BARS

Revisions made to this document are indicated with a line along the left or right hand column in the area the revision was made. These revisions are to technical information and any other changes in spelling, grammar or formatting are not included.

ASSOCIATED LITERATURE

MANUAL DESCRIPTION	FORM NUMBER
York Air Handling Units Operation and Maintenance	102.20-OM1
Steps to Protect New Equipment Warranty	102.20-CL1
Air Handling Units Start-up Checklist	100.00-CL1
Long-Term Storage Requirement - Field Preparation - Air Handling Units	50.20-NM3
Long-Term Storage Periodic Checklist and Logs - Air Handling Units	50.20-CL3
Limited Warranty	50.05-NM2
Electric Motor Warranty	50.05-NM2.2
Air Cooled Condensing Unit DX Coil Split System Applications and Piping Guidelines	50.40-ES3
Air Modulator Service & Warranty Procedure	SI0262

THIS PAGE INTENTIONALLY LEFT BLANK.

TABLE OF CONTENTS

SECTION 1 - GENERAL INFORMATION AND SAFETY	13
Introduction.....	13
Warranty.....	13
Responsibility for Safety.....	13
SECTION 2 - PRODUCT DESCRIPTION	15
Typical AHU Operation	15
Ventilation System.....	15
Economizer System (Typical).....	15
Heating and Cooling System.....	16
Cleaning	16
Hand Orientation	16
AHU Identification (ID).....	16
SECTION 3 - HANDLING, STORAGE, AND INSTALLATION	19
Delivery and Storage.....	19
Inspection, Damage, and Shortage	19
Short Term.....	19
Long Term	19
Receiver's Responsibility	20
Indoor AHUs.....	20
Outdoor AHUs	20
Shipped Loose Parts.....	20
Lifting Weights	21
Moving the AHU	21
Lifting and Handling.....	21
Bolted Loosely / Shipped in One Piece	22
Rigging	22
Using Fork Lift in Special Circumstances.....	22
Come-A-Longs (Power Pulls).....	22
Proper Lifting with Shackles	22
Preparing the Site.....	23
Clearance for Outdoor AHUs.....	24
Roof Curb Assembly (Optional).....	24
Roof Curb Installation.....	25
Clearance and Mounting for Indoor AHUs.....	26
Installing Ceiling Suspended AHUs.....	26
Tools Required to Install AHU.....	28
Installing Outdoor AHU	28
Single Piece Outdoor AHU	28
Installing the YORK Custom AHU	29
General.....	29
Removable Lifting Lugs.....	29
Electrical Wiring/Piping.....	29
Reassembly Procedure for Vertical Split Unit.....	30

TABLE OF CONTENTS (CONT'D)

Outdoor Split Roof Sealant Procedure	32
Installing Hood with Moisture Eliminators.....	36
Outdoor Air Temperature and/or Humidity Sensors.....	36
Installing Damper Actuator	37
Installing Multi-Zone (MZ) Dampers	38
Installing Field Supplied MZ Damper Actuators	39
Back Draft Dampers for Dual Fans and Fan Arrays	39
Filling Inertia Fan Base	40
Steam Humidifier.....	40
UVC Emitter Lamps.....	40
Two Types of Lamps	40
Air Measuring Device Connections	44
Air Measuring at the Fan Inlets	44
Air Measuring at Unit Outside Air Inlets.....	44
Installing External Vent Piping for Outdoor AHUS.....	45
Condensate Drain Arrangement.....	45
Field Penetrations for Piping and Electrical Connections.....	47
General Electrical Information	49
Power Connections	49
Single Point Power.....	49
Motors for Supply, Return, and Exhaust Fans.....	50
Wiring the Energy Recovery Wheel	50
Wiring the Gas Heat Device	51
Wiring the Electric Heat Device.....	52
Power Options.....	52
Disconnect Switch Options.....	52
Control Options	53
Installing Electrical Heat Option	53
Electric Humidifier	56
Humidifier	56
Coil Piping	57
Staggered Coils.....	57
Hot and Chilled Water Coils	58
Water Treatment.....	60
Vertical Tube Integral Face and Bypass (VIFB) and Integral Face and Bypass (IFB).....	62
Shipping Bolts (VIFB Only).....	62
Piping Suggestions	62
Flexible Connectors (VIFB Only).....	62
Freezing Conditions	62
Refrigeration.....	66
DX Direct Expansion Coils	66
Available Coil Arrangements	68
Thermostatic Expansion Valves (TXV)	70
Hot Gas Bypass (HGBP).....	70
Dx Coil Circuiting and Staging.....	70
Advantages of Multiple Control Stages	71
Maintaining Adequate Airflow	71
VAV Systems	72

TABLE OF CONTENTS (CONT'D)

Drains and Traps	72
Condensate Drain Piping	72
Elevating AHU for Gravity Floor Drain Connections	73
Duct Connections	74
Duct Connection Guidelines	74
Flanged Duct or Sleeves	74
Raw or Straight Edge Duct or Sleeves	74
Sound and Vibration Transmission	75
Installing Top Discharge Outdoor AHU Duct	75
Installing Front and Rear Discharge Outdoor AHU Duct	75
Air Filters	77
Maintaining and Replacing Filters	77
Filter Installation	
Installing a 2 in. Pleated Filter	81
Installing a 4 in. Pleated Filter	81
Installing a Single Headered (SH) Filter	82
Installing a 2 in. Pre-Filter Combined with a SH Final Filter	82
Installing a Multi-Cell SBM Double Headered (DH) Filter	83
Installing a 2 in. and 4 in. Pre-Filter Combined with a DH Final Filter	84
Temperature	87

LIST OF FIGURES

FIGURE 1 - Cutaway of ahu Showing Segmented Construction.....	15
FIGURE 2 - AHU and Coil Hand Identification	16
FIGURE 4 - Typical Come-A-Longs	22
FIGURE 3 - Recommended Lifting with Multiple Points	22
FIGURE 5 - Lifting Lugs	23
FIGURE 6 - Proper Lifting with Base Rail.....	23
FIGURE 7 - Minimum Service Clearances.....	24
FIGURE 8 - Roof Curb Detail	25
FIGURE 9 - No Housekeeping Pad - Base Required to Accomodate Trap Height	26
FIGURE 10 - With Base and Housekeeping Pad.....	26
FIGURE 12 - Ceiling Suspended Unit	27
FIGURE 11 - Ceiling Suspended AHU	27
FIGURE 13 - Tools Needed to Assemble Shipping Splits	28
FIGURE 14 - Typical Cabinet Split	29
FIGURE 15 - Base Assembly Attachment	30
FIGURE 16 - Split Reassembly Procedure for Outdoor Units Only.....	31
FIGURE 17 - Split Reassembly Procedure	32
FIGURE 18 - Outdoor Split Sealant Procedure on Roofs with ACU Option	33
FIGURE 19 - Horizontal Split.....	33
FIGURE 20 - Cross Section of Split Wall Assembly	34
FIGURE 21 - Multi-section Gasket Installation on Thermal Break Units	35
FIGURE 22 - Installing Hood with Optional Moisture Eliminators.....	36
FIGURE 23 - Installing the Direct Coupled Actuator.....	37
FIGURE 24 - Installing MZ Damper.....	38
FIGURE 25 - Damper Shaft Extension Kit (P/N 026-33715-002).....	39
FIGURE 26 - Counterbalance Locked Into Place for Shipping.....	39
FIGURE 27 - Counterbalance Unlocked for Start-Up.....	39
FIGURE 28 - V-Max Grid Lamps	40
FIGURE 29 - Installing V-Mod Lamp	40
FIGURE 30 - Installing V-Max Grid Lamps.....	40
FIGURE 31 - UV Control Panel Wiring (8 amps).....	41
FIGURE 32 - UV Control Panel Wiring (Greater than 8 amps)	42
FIGURE 33 - High and Low Connections for an in Fan Air Monitoring System.....	44
FIGURE 34 - High and Low Connections and Associated Tubing for Fan Mounted Air Monitoring System	44
FIGURE 35 - Port Locations for Fan Mounted Air Monitoring System	44
FIGURE 36 - Gas Furnace Fuel Venting System.....	45
FIGURE 37 - Gas Furnace Condensate Drain Trap.....	46
FIGURE 38 - Gas Furnace Drain Trap	48
FIGURE 39 - Single Point Power Connection	49
FIGURE 40 - Typical Motor Data/Name Plate	50
FIGURE 41 - Another Typical Motor Data/Name Plate.....	50
FIGURE 42 - Access Electrical Box.....	50
FIGURE 43 - Typical Power Wiring of Energy Recovery Wheel	51
FIGURE 44 - Gas Burner Component Locations	51
FIGURE 45 - Main Power and Control Panel with Cover Open	51
FIGURE 46 - Typical Field and Power Connections.....	52
FIGURE 47 - Typical Electrical Heat Control Panel Interior Wiring and Components.....	52

LIST OF FIGURES (CONT'D)

FIGURE 48 - Pressure Probe Direction.....	54
FIGURE 49 - Air Flow Switch Connections	54
FIGURE 50 - Layout of Typical Humidifier Panel	56
FIGURE 51 - Supply Power Knockouts.....	56
FIGURE 52 - Humidifier Points.....	56
FIGURE 53 - Factory Coil Connections.....	57
FIGURE 54 - Staggered Coil - Angled Wall.....	57
FIGURE 55 - Split Coil - Opposite Side Connections.....	57
FIGURE 56 - Chilled Water Coil Connections Example - (Not for Construction)	58
FIGURE 57 - Hot Water Piping with Two-Way Valve Example (Not for Construction)	59
FIGURE 58 - Hot Water Piping with Diverting Valve Example (Not for Construction).....	59
FIGURE 59 - Steam Coil Piping Arrangements.....	61
FIGURE 60 - IFB Coil (Horizontal Tubes Available with Steam and Hot Water)	63
FIGURE 61 - VIFB Coil (Face-Mounted Actuator Shown).....	64
FIGURE 62 - Hot Water Piping for IFB.....	64
FIGURE 63 - Hot Water Piping Schematic for 2-Row Coil VIFB	64
FIGURE 64 - Steam Piping for VIFB	65
FIGURE 65 - Typical Piping and Sundries at the DX Coil	67
FIGURE 66 - DX Coil Circuiting Types	67
FIGURE 67 - Non-Stacked Coil Design (Special Quote).....	68
FIGURE 68 - Non-Stacked Coil Design (Standard).....	68
FIGURE 69 - Stacked Coil Design (Standard)	69
FIGURE 70 - Stack Coil Designs (Special Quote).....	69
FIGURE 71 - Stacked Coil Circuiting.....	70
FIGURE 72 - One Coil Circuit Per Refrigerant Circuit.....	70
FIGURE 73 - Two Coil Circuit Per Refrigerant Circuit	70
FIGURE 74 - Three Compressor Unit	71
FIGURE 75 - Six Compressor Unit.....	71
FIGURE 76 - Drain Trap Showing Water Location for Draw Through Operation	73
FIGURE 77 - Trap Detail for Drain Pan in Negative Environment (Draw Through).....	73
FIGURE 78 - Trap Detail for Drain Pan in Positive Environment (Blow Through).....	73
FIGURE 79 - Combining Drain Lines	73
FIGURE 80 - Recommended Discharge Duct Arrangement when Turns are Required.....	74
FIGURE 81 - Duct Arrangement for Flange and Raw Edge Ducts.....	75
FIGURE 82 - Duct Penetration of Roof	76
FIGURE 83 - Roof to Duct Installation (Horizontal Discharge).....	76
FIGURE 84 - Typical Filter Types	77
FIGURE 85 - Filter Latches	78
FIGURE 86 - Correctly Installed Latch Pin (P/N 026-35788-702)	81
FIGURE 87 - Fully Installed Filter.....	81
FIGURE 88 - Correctly Installed Latch Pin (P/N 026-35788-604)	81
FIGURE 89 - Place the End of the Latch Over the Filter Frame	82
FIGURE 90 - Correctly Installed Cartridge Filter	82
FIGURE 91 - Correctly Installed Latch Pin (P/N 026-35788-604)	83
FIGURE 92 - Correctly Installed Cartridge with Pleats.....	83
FIGURE 93 - Correct use of Knockouts	83
FIGURE 94 - Correct Latchout/Knockout Configuration.....	83

LIST OF FIGURES (CONT'D)

FIGURE 95 - Frame with Four Latches Installed on the Sides.....	84
FIGURE 96 - Spring Latch Pulled and Fastened in Filter Hole	84
FIGURE 97 - Correct Latchout/Knockout Configuration (P/N 026-35788-612).....	84
FIGURE 98 - Spring Latch Pulled and Fastened in Filter Hole	85
FIGURE 99 - Installing Pre-Filter Latch	85
FIGURE 100 - Position Pre-Filter in Front of Final Filter	85
FIGURE 101 - Spring End of Latch	85
FIGURE 102 - Completed Assembly	85
FIGURE 103 - Installation of Hepa Filters	86

LIST OF TABLES

TABLE 1 - Definition of Segment IDS	17
TABLE 2 - TSP and Drain Trap	46
TABLE 3 - Maximum Current	55
TABLE 4 - Koch Filter Clips - Single Filter Application	79
TABLE 5 - Koch Filter Clips - Pre-Filter / Final Filter Application	79
TABLE 6 - AAF Clips for Filter Frames - Single Filter Application	80
TABLE 7 - AAF Pre-Filter/Final Filter Application	80
TABLE 8 - SI Metric Conversion	87

SERVICE TASK REFERENCE

Air Filters	77
Installing a 2 in. Pleated Filter	81
Installing a 4 in. Pleated Filter	81
Installing a Single Headered (SH) Filter	82
Installing a 2 in. Pre-Filter Combined with a SH Final Filter	82
Installing a Multi-Cell SBM Double Headered (DH) Filter	83
Installing a 2 in. and 4 in. Pre-Filter Combined with a DH Final Filter	84
Air Measuring Device Connections	44
Clearance and Mounting for Indoor AHUs	26
Coil Piping	57
Staggered Coils	57
Hot and Chilled Water Coils	58
Water Treatment	60
Condensate Drain Arrangement	45
Drains and Traps	72
Condensate Drain Piping	72
Elevating AHU for Gravity Floor Drain Connections	73
Duct Connections	74
Duct Connection Guidelines	74
Flanged Duct or Sleeves	74
Raw or Straight Edge Duct or Sleeves	74
Sound and Vibration Transmission	75
General Electrical Information	49
HEPA Filters	86
Hot Gas Bypass (HGBP)	70
Inspection, Damage, and Shortage	19
Receiver's Responsibility	20
Installing Ceiling Suspended AHUs	26
Installing Damper Actuator	37
Installing Multi-Zone (MZ) Dampers	38
Installing Field Supplied MZ Damper Actuators	39

Installing External Vent Piping for Outdoor AHUs	45
Installing Hood with Moisture Eliminator	36
Installing Outdoor AHU	28
Single Piece	28
Long Term Storage	19
Power Connections	49
Single Point Power	49
Wiring the Gas Heat Device	51
Wiring the Electric Heat Device	52
Electric Humidifier	56
Humidifier	56
Preparing the Site	23
Proper Lifting with Shackles	22
Refrigeration	66
DX Direct Expansion Coils	66
Available Coil Arrangements	68
Rigging	22
Indoor and Outdoor AHUs	22
Roof Curb	24
Assembly	24
Installation	25
Shipped Loose Parts	20
Short Term Storage	19
Thermostatic Expansion Valves (TXV)	70
Tools Required to Install AHU	28
UVC Emitter Lamps	40
Two Types of Lamps	40
VAV Systems	72
VIFB and IFB	62
Shipping Bolts	62

THIS PAGE INTENTIONALLY LEFT BLANK.

SECTION 1 - GENERAL INFORMATION AND SAFETY

INTRODUCTION

The air handling unit (AHU) is manufactured to the highest design and construction standards to ensure high performance, reliability and adaptability to all types of air handling installations.

This manual and any other document supplied with the AHU are the property of Johnson Controls, which reserves all rights. This manual may not be reproduced, in whole or in part, without prior written authorization from an authorized Johnson Controls representative.

In addition, this manual:

- Includes suggested best working practices and procedures, which are issued for guidance only, and they do not take precedence over the above stated individual responsibility and/or local safety regulations.
- Contains all the information required for correct installation and commissioning of the AHU, together with operating and maintenance instructions.
- Should be read thoroughly before attempting to operate or service the AHU.
- Contains detailed procedures, including installation, commissioning and maintenance tasks that must only be performed by suitably trained and qualified personnel.

Rigging and lifting should only be done by a professional rigger in accordance with a written rigging and lifting plan. The most appropriate rigging and lifting method will depend on job specific factors, such as the rigging equipment available and site needs. Therefore, a professional rigger must determine the rigging and lifting method to be used, and it is beyond the scope of this manual to specify rigging and lifting details.

The manufacturer will not be liable for any injury or damage caused by incorrect installation, commissioning, operation, or maintenance resulting from a failure to follow the procedures and instructions detailed in the manual.

WARRANTY

Johnson Controls warrants AHUs in accordance with the Limited Warranty Engineered Systems Equipment procedure. Refer to the *Standard Limited Warranty*

Engineered Systems Equipment (Form 50.05-NM2) for more information.

Johnson Controls warrants all equipment and materials against defects in workmanship and materials for a period of 18 months from the date of shipment or 12 months from the date of start-up, whichever comes first, unless labor or extended warranty has been purchased as part of the contract.

The warranty is limited to parts only replacement and shipping of any faulty part, or subassembly, which has failed due to defects in workmanship and materials. All claims must be supported by evidence that the failure has occurred within the warranty period, and that the AHU was operated within the designed parameters specified.

All warranty claims must specify the AHU model, serial number, order number, and run hours/starts. Model and serial number information is printed on the AHU identification plate.

The AHU warranty will be void if any modification to the AHU is carried out without prior written approval from Johnson Controls. For warranty purposes, the following conditions must be satisfied:

- Only genuine YORK approved spare parts must be used.
- All of the scheduled maintenance operations detailed in this manual must be performed at the specified times by suitably trained and qualified personnel.
- Failure to satisfy any of these conditions will automatically void the warranty. Refer to *Standard Limited Warranty Engineered Systems Equipment (Form 50.05-NM2)* for details.

RESPONSIBILITY FOR SAFETY

Every care has been taken in the design and manufacture of the AHU to ensure compliance with the safety requirements. However, the individual operating or working on any equipment is primarily responsible for:

- Personal safety, safety of other personnel, and the equipment.
- Correct utilization of the equipment in accordance with the procedures detailed in this manual.

THIS PAGE INTENTIONALLY LEFT BLANK.

SECTION 2 - PRODUCT DESCRIPTION

The AHU features segmented construction, and is factory assembled. Segment arrangements will vary to suit the job application as shown in *Figure 1 on page 15*. Features of the AHU include:

- Heavy gauge galvanized steel, stainless steel, and aluminum can be used on the exterior and interior of the AHU.
- Access doors are provided for accessibility to the various sections.
- Panels and doors are constructed with double walls.
- Panels, doors, and structural frame are insulated with spray-injected foam.

TYPICAL AHU OPERATION

The operation of the AHU is divided into four systems:

1. Ventilation
2. Economizer (Return Air/Mixing Box Section)
3. Heating and Cooling
4. Cleaning

Ventilation System

The purpose of a ventilation system is to remove air that is substandard to creature comfort or a process, and replace it with suitable air. Depending on the application, the system will operate at various specified rates, volumes, and conditions. A ventilation system may employ an AHU with a supply fan working in conjunction with a remote exhaust fan(s). A more effective method would employ a supply fan and an exhaust fan in the AHU.

Economizer System (Typical)

The economizer system typically consists of:

- Outdoor and return air dampers
- Damper actuator
- Enthalpy control
- Minimum outdoor air adjustment
- Exhaust air control

The economizer system provides the first stage of cooling whenever the outdoor air is cool and dry enough to satisfy the internal cooling demand. The outdoor and the return air dampers are operated by individual actuators. As the outdoor air dampers are opened by the damper actuator, the return air dampers are closed.

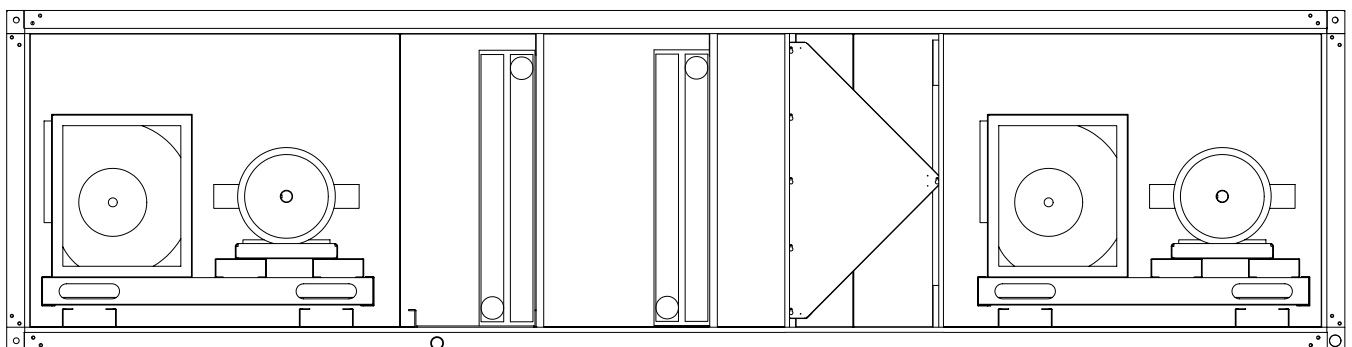

LD13764

FIGURE 1 - CUTAWAY OF AHU SHOWING SEGMENTED CONSTRUCTION

Heating and Cooling System

Various types of heating and cooling may be applied, which include:

- Hot water or steam coils
- Electric or fuel burner heat
- Factory mounted chilled water coils
- Direct expansion refrigerant coils

Cleaning

Various types of cleaning include filters and UV lights.

HAND ORIENTATION

Coil connections and other components are located and described as left or right hand. The proper orientation to describe the proper hand is when airflow is at your back as shown in *Figure 2 on page 16*.

AHU IDENTIFICATION (ID)

Indoor and outdoor AHUs are labeled with the following ID labels:

- AHU
- Skid
- Loose Components

Indoor AHUs are shrink wrapped with skid ID labels on the outside of the wrapping and on each skid.

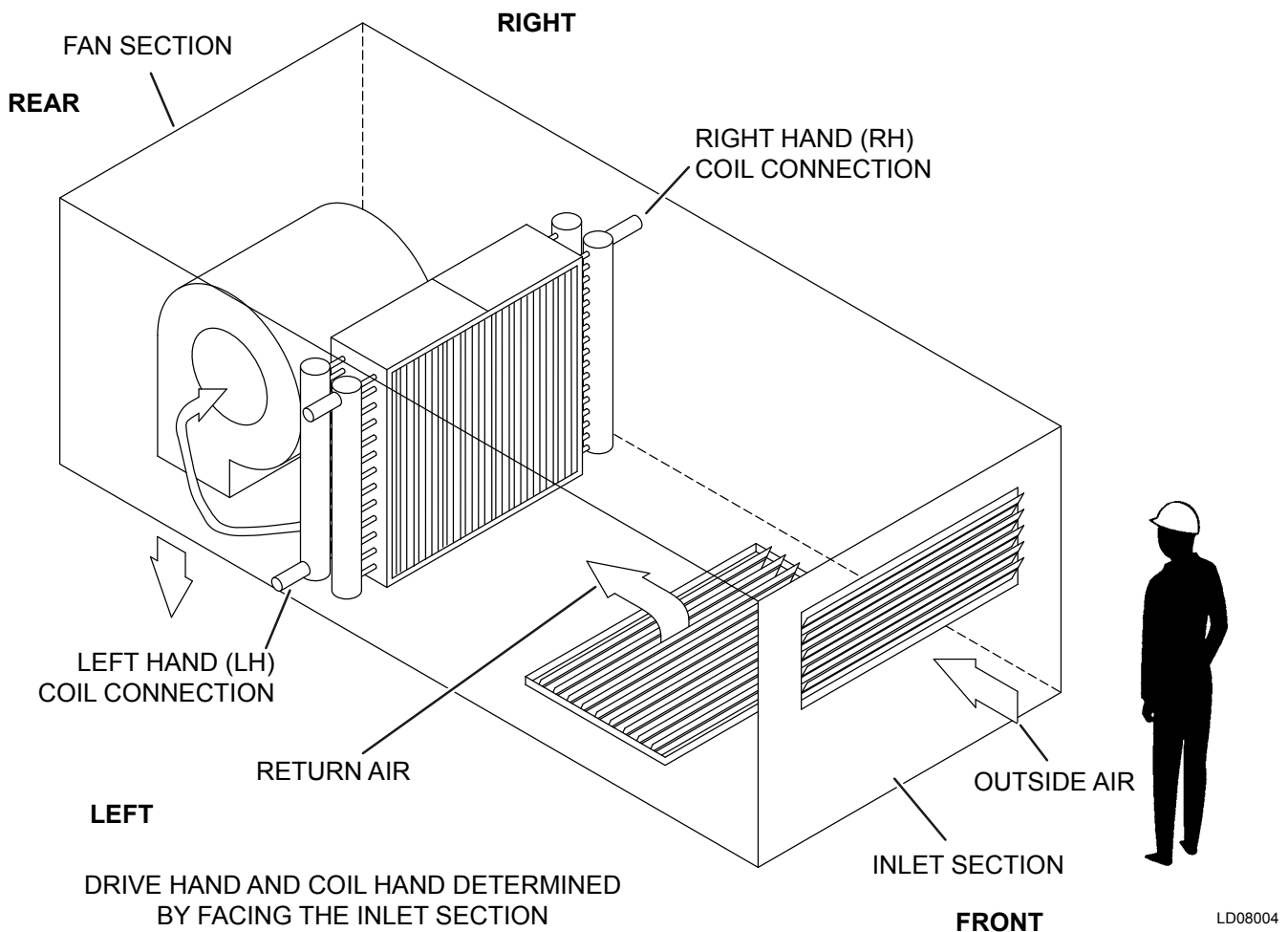

FIGURE 2 - AHU AND COIL HAND IDENTIFICATION

TABLE 1 - DEFINITION OF SEGMENT IDS

FAN SEGMENTS
FS – SUPPLY
Forward Curved DWDI
Airfoil DWDI
Industrial Airfoil DWDI
SWSI Airfoil Plenum (Belt and Direct Drive)
FR – RETURN
Forward Curved DWDI
Airfoil DWDI
Industrial Airfoil DWDI
SWSI Airfoil Plenum (Belt and Direct Drive)
FE – EXHAUST
Forward Curved DWDI
Airfoil DWDI
Industrial Airfoil DWDI
SWSI Airfoil Plenum (Belt and Direct Drive)
COIL SEGMENTS
CC – COOLING COIL
HC – HEATING COIL
VC – VERTICAL COIL
MZ – MULTI-ZONE
HEAT SEGMENTS
IC – INTEGRAL FACE AND BYPASS COIL
IG – INDIRECT GAS FIRED FURNACE
EH – ELECTRIC HEATER
ENERGY RECOVERY
ER – HEAT WHEEL
HW – HEAT WHEEL

FILTER SEGMENTS
FF – FLAT FILTER (2 or 4 in.)
AF – ANGLE FILTER (2 or 4 in.)
RF – HIGH EFFICIENCY FILTER
Rigid Filter (12 in.)
Bag Filter (21 in.)
Mini-Pleat Filter (4 in.)
HF – HIGH EFFICIENCY FILTER
INLET SEGMENTS
MB – MIXING BOX
FM – FILTER/MIXING BOX
EF – FILTER/ECONOMIZER
EE – ECONOMIZER
IP – INLET PLENUM
VE – VERTICAL ECONOMIZER
VF – VERTICAL FILTER/ECONOMIZER
IO – INLET/OUTLET
ACCESSORY SEGMENTS
VP – VERTICAL PLENUM
DP – DISCHARGE PLENUM
TN – TURNING PLENUM
DI – DIFFUSER
XA – ACCESS SEGMENT
AB – AIR BLENDER
EB – EXTERNAL BYPASS
IB – INTERNAL BYPASS
FD – FACE DAMPER
HM – HUMIDIFIER
AT – SOUND ATTENUATOR
UV – UV LIGHTS

THIS PAGE INTENTIONALLY LEFT BLANK.

SECTION 3 - HANDLING, STORAGE, AND INSTALLATION

DELIVERY AND STORAGE

To ensure consistent quality and maximum reliability, all AHUs are tested and inspected before leaving the factory.

Inspection, Damage, and Shortage

Check the AHU shipment on arrival to make sure that all major pieces, boxes, and crates are received. Check each AHU on the trailer or rail car when received, before unloading, for any visible signs of damage. Report any damage or signs of possible damage to the transportation company immediately for its inspection.

After inspecting the AHU for damage, open all containers and check the contents against the packing list. Report any material shortage to Johnson Controls immediately.

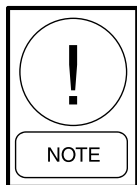

JOHNSON CONTROLS WILL NOT BE RESPONSIBLE FOR ANY DAMAGE OR LOSS OF PARTS IN SHIPMENT OR AT JOB SITE. REFER TO SHIPPING DAMAGE CLAIMS (FORM 50.15-NM).

Short Term

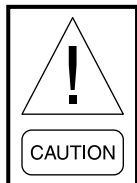

Indoor AHUs: Under no circumstances should outdoor storage be used.

- ***Remove of ventilate wrapping to prevent condensation.***

Outdoor AHUs: Recover AHUs after inspection or use tarps during storage.

Short term storage is six months or less from date of shipment. Storage maintenance during this time is usually limited to the following:

- Rotate fans every four weeks, starting on the delivery date to prevent moisture from damaging the bearing.
- If the AHUs are going to be stored out-of-doors, prior to installation, special care must be taken to cover and protect the AHUs from:
 - Dust
 - Rain and snow
 - Rodents
 - Construction vehicles and personnel.
 - Condensation / Ventilation required

- Protect all parts and porous materials from rain and other sources of moisture. Decontaminate or replace parts as needed to make sure microbial growth is not introduced to the AHU.
- Store the AHU on a firm, flat surface to prevent distortion. Block the AHU off the ground to protect components from water or ground moisture.

Long Term

Long term storage is more than six months from the date of shipment. If long term storage is anticipated, contact the Johnson Controls sales representative for the proper instructions and requirements.

It is mandatory that a detailed record be maintained during this long term period, such as, but not limited to the following:

- Proper sealing of the cabinet,
- Rotation of the blowers and bearings, and
- Protection of all motors from moisture.

Refer to *Long Term Storage Requirement - Field Preparation (Form 50.20-NM3)* and *Long Term Storage Periodic Checklist and Logs (Form 50.20-CL3)* for more information.

Preventive Maintenance Prior to Long Term Storage

Take the following precautions prior to extended storage:

- Grease the fan and motor bearings per the manufacturer's specifications.
- Protect the motors and sheaves from free moisture or high humidity, which may be accomplished by:
 - Spraying components with an anti-rust solution (P/N 026-37707-000).
 - Disconnecting the belts. Wrapping the sheaves and motor and sealing them with plastic. Inserting a desiccant to absorb moisture that may penetrate the plastic protection.
- Meg the fan motor windings and record for comparison prior to placing the AHU in service.
- If the fan housing was supplied with a drain connection, remove the plug to prevent moisture from accumulating in this part of the fan during storage.

Periodic Fan Check

On a monthly basis, perform the following tasks:

- Rotate the fan and motor several times to replenish the bearing surfaces with fresh grease.
- Turn the fan impeller 180° from the previous month's position to prevent the belts from taking a set position.

Monthly Log Sheet

It is the customer's responsibility to submit a monthly log sheet from the *Long Term Storage Periodic Checklist and Logs (Form 50.20-CL3)* that shows the condition of the AHU and to note any discrepancies. Send a copy of the log sheet to the Johnson Controls Field Service Office for its records.



Failure to fulfill the long term storage requirements will void the warranty.

Receiver's Responsibility

The receiver is solely responsible for noting the freight bill and filling out the freight claims IMMEDIATELY. In addition, the receiver must:

- Note the visible damage on the signed and dated bill of lading with a request that the carrier inspect the damage within 72 hours of notification.
- Remove the shipping wrapper, and replace it with a tarp or similar protective covering. Any concealed damage reported after 15 days will compromise a claim settlement.

- Request inspections by telephone or in person, but confirm in writing. If assistance is needed with the claim process, contact a Johnson Controls sales representative and refer to the shipping damage form.

Indoor AHUs

It is Johnson Controls' intention that a shipping wrapper be applied to unpainted indoor AHUs for protection from weather, road dirt, etc. during inland transit. Remove the wrapper at the time of delivery to allow for a thorough inspection, both inside and out. Under no circumstances should outdoor storage be used.

Outdoor AHUs

Generally, outdoor AHUs are not fully wrapped. Exposed openings will be covered for protection from weather, road dirt, etc. during inland transit. Conduct a thorough inspection, inside and out, at the time of delivery.

Occasionally, an outdoor AHU may be entirely wrapped in plastic, which should not be removed until the AHU is installed, to prevent damage from job site dirt and various weather conditions. If the AHU is covered with plastic, cut the wrap in the outline of the door(s), and proceed to access the AHU using the information (above). Close the cut with duct tape.

Shipped Loose Parts

Check the packing list, which notes the number and types of parts, for non-mounted shipped loose parts in all segments of the AHU. Report shortages within 10 days after receipt of the order.

LIFTING WEIGHTS

AHU section weights are furnished on the job submittal form. Due to the variance in weight of each AHU design, it is not possible to list AHU weights in these instructions. Refer to the job submittal form when selecting a crane for rigging and figuring out roof weight loads. Contact a Johnson Controls sales representative, if there are questions regarding the AHU weights.

MOVING THE AHU

Prior to moving the AHU, make sure that the installation site is suitable for installing the AHU, and is easily capable of supporting the weight of the AHU and all associated services.

LIFTING AND HANDLING

The unit will ship (as specified on unit submittal) either assembled, as a subassembly (collection of parts), or as individual sections.

To prepare for safely lifting the air-handling unit, estimate the approximate center of gravity. Internal placement of components may cause the weight to be unevenly distributed, with more weight in the coil and fan areas.

An experienced and reliable rigger must handle the unloading and final placement of the AHU and must be advised of the following:

- AHU contains internal components and should be handled in an upright position.
- Car must be exercised to avoid twisting the equipment structure.
- Prevent unnecessary jarring or rough handling.

Removable lifting lugs are provided to raise the unit. (Lifting lugs are typically shipped in fan section and must be installed before lifting. *Lifting lugs are attached to unit base when shipping section is ordered with “fully wrap” shipping cover.) Spreader bars are required to prevent damage to the cabinet and protruding components during a lift. Use all lifting lugs provided. Adjust the tension in each line for proper load distribution.



Unit sections are bolted together for shipping purposes. Sections must be separated and sealed prior to final installation and operation.

WARNING

Failure to follow these instructions could result in death, serious injury or equipment damage.

Follow all warnings and instructions in the unit's Manual(s).

<p>EN Installation Instructions for the technician / fitter</p> <p>PL Instrukcja instalacji dla technika / monter</p> <p>SV Installationsguide för installatör / montör</p> <p>CS Pokyny k instalaci pro techniky a montéry</p>	<p>IT Istruzioni d'installazione per il personale specializzato</p> <p>NL Installatiehandleiding voor de vakman / monteur</p> <p>DE Installationsanleitung für die Fachkraft / Monteur</p> <p>ES Instrucciones de instalación para el técnico / contratista especializado</p>	<p>JA 一般仕様・取扱説明書</p> <p>FR Manuel d'installation pour le spécialiste / monteur</p> <p>RU Инструкция по установке для техника/монтажника</p> <p>ZH 适用于技术人员与安装人员的 安装说明书</p>	
---	---	---	--

1. Follow all applicable regulations and safety practices during rigging and lifting.
2. Prepare and follow written rigging and lifting plan.
3. Rigging must be directed by trained professional rigger.
4. Spreader bars must be used and be long enough to prevent rigging from contacting unit.
5. Use all and only designated lift points according to units manual(s).
6. Locate center of gravity through trial lifts to account for possible variations in unit configuration.
7. Use rigging and lifting techniques that keep unit stable and level.
8. Keep clear of unit when lifted.

035-23962-000 REV A

LD19197



Rigging and lifting should only be done by a professional rigger in accordance with a written rigging and lifting plan. The most appropriate rigging and lifting method will depend on job specific factors, such as the rigging equipment available and site needs. Therefore, a professional rigger must determine the rigging and lifting method to be used, and it is beyond the scope of this manual to specify rigging and lifting details.

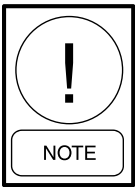

Use a spreader bar to avoid damage to the unit, accommodate multiple lifting lugs, and maintain maximum specified angles..

BOLTED LOOSELY / SHIPPED IN ONE PIECE

Split units may be shipped “loosely” assembled to reduce freight costs. The split sections are fastened together using a minimum number of bolts for transit and can be removed off the truck to the ground. Disassembly is required before lifting to the roof. Each section must be lifted individually to the roof.

Rigging



Remember - when lifting; use all lifting lugs to avoid damage and/or personal injury. Lifting lugs are shown in Figure 5 - Lifting Lugs on page 23.

If there are no lifting lugs, a belt type sling should be used to raise the unit. Be cautious in avoiding protrusions such as electrical boxes, coil connections, and door handles.

Do not lift non-base units or subassemblies by attaching clevis, hooks, pins, bolts, etc. to casing, casing hardware, angles, tabs or flanges.

Lift the air-handling unit only in an upright position. Never lift or move a unit on its side or upside-down.



If you do not rig or lift the unit carefully, you could damage the unit, hurt yourself or others. Use Caution!

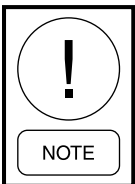

Outdoor Custom units have an optional roof coating applied where light foot traffic is permitted, but storage of materials typically found on construction sites are not permitted to be placed on roofs. Care must be taken not to damage the roof coating.

If other than light foot traffic or storage of materials becomes necessary, plywood may be placed on the roof provided the weight applied does not exceed 50lbs. per sq. ft.

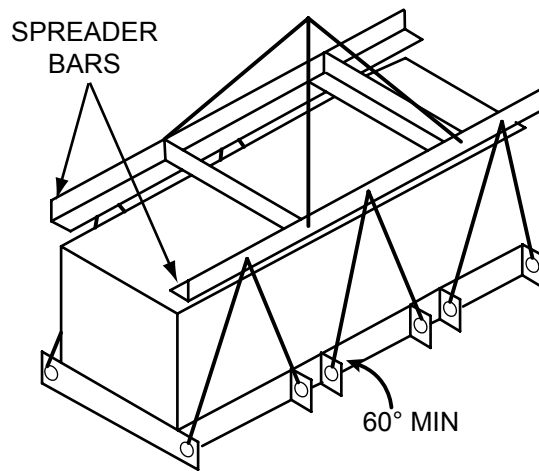

LD13765b

FIGURE 3 - RECOMMENDED LIFTING WITH MULTIPLE POINTS

USING FORK LIFT IN SPECIAL CIRCUMSTANCES

Forklifts should not be used to off-load AHUs except in special circumstances. If moving an AHU with a fork lift or similar equipment becomes necessary, make sure the lifting forks are long enough to reach from the fork truck to the opposite side and slightly beyond the AHU. Leave the shipping blocks attached to the bottom of the AHU until it is moved to its final location. There is no structural support under the equipment except what is visible from the perimeter.

COME-A-LONGS (POWER PULLS)

If the AHU has multiple sections, use come-a-longs (power pulls) as shown in Figure 4 on page 22 to pull the sections or skids together.



LD09613a

FIGURE 4 - TYPICAL COME-A-LONGS

PROPER LIFTING WITH SHACKLES

Shackles are fastened to a sling or chain, which is used to lift and lower the sections in a tiered AHU. Refer to the Figure 5 on page 23 and Figure 6 on page 23 for proper lifting.

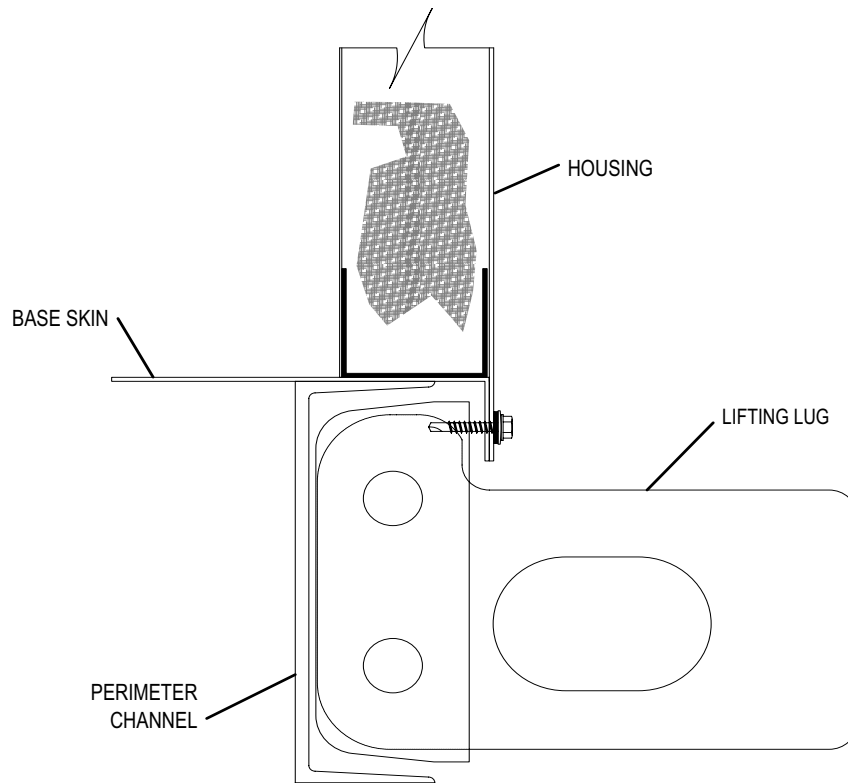

FIGURE 5 - LIFTING LUGS

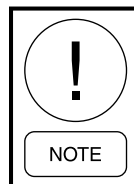

FIGURE 6 - PROPER LIFTING WITH BASE RAIL

PREPARING THE SITE



Do not weld or use torches on the exterior or interior of the AHU housing. The housing contains polyurethane insulation, which, under combustion, will produce harmful, toxic gases resulting in personal injury or death.



Never use silicone caulk/sealant in or on any AHU.



If the AHU has HEPA filters, the filter frames, bulkheads, and segment panels are factory sealed, and must remain sealed to prevent air bypass.

Clearance for Outdoor AHUs

Locate the AHU away from building flue stacks or exhaust ventilators to prevent possible introduction of contaminated air through the outside air intakes as shown in *Figure 7 on page 24*.

To make sure that the AHU fits properly into the selected location, use the following instructions.

- Allow sufficient space around the AHU to remove the access panels and various parts.
- Provide a minimum clearance equal to the width of the AHU plus 6 in. on one side to remove the coil or fan assembly. Consider the coil access panel for coil removal.
- Add the dimensions of the pipe chase, air hoods, ducts, control/electrical panels, etc. to meet minimum clearances.
- Allow any additional clearances as required by local and National Electrical Codes (NEC).

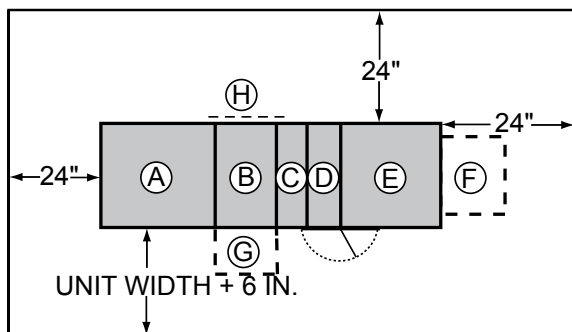

Mounting the Outdoor AHU

Install AHUs to provide enough elevation for properly designed condensation traps.

The area of the roof on which the curb is to be installed must be structurally adequate to support the combined weight of curb, AHU, and system fluids. With these combined weights in place, the resting surface for the AHU MUST be flat and level.

Concrete pads may not be as flat as they should be. Shimming and/or grouting may be necessary. Whether under the AHU base or curb, the AHU base needs to be on a flat plane.

MIN. CLEARANCE DIMENSIONS

- Ⓐ Fan Section
- Ⓑ Coil Section
- Ⓒ Face and Bypass Damper Section
- Ⓓ Filter Section - Door should open 180°
- Ⓔ Inlet Section
- Ⓕ Rain Hood (add unit width or length)
- Ⓖ Pipe Chase Enclosure (add to unit width)
- Ⓗ Coil Access Panel on Outdoor Unit (allow clearance = to unit width)

LD6326-4

FIGURE 7 - MINIMUM SERVICE CLEARANCES

Roof Curb Assembly (Optional)

1. When supplied by Johnson Controls, roof curbs ship either fully welded or in pieces. If bolted curb construction, bolt together.
2. Curb must be level (shim if required). Shims should be placed at intervals no larger than 5 feet apart. On large units with splits, remember to shim at the split's mid-span (see *Figure 14 on page 29*).
3. The installer is responsible to secure roof curb to the building structural support in accordance with local building and earthquake codes.
4. Seal all roof curb joints and seams with suitable sealer/polyurethane caulk to prevent water leakage.

Roof Curb Installation

1. Check that the curb is level and secured to the roof.
2. Check that there is adequate height between the base of the unit and the roof to allow for drain trapping.
3. Install 1/8" thick neoprene gasket, on the top of the curb to provide a seal between the unit and the roof curb. If units must be slid into place, a polyurethane sealant may be used in lieu of the gasket.
4. Lift the unit in place.
5. The installer is responsible to secure installation in accordance with the local building and earthquake codes.

3

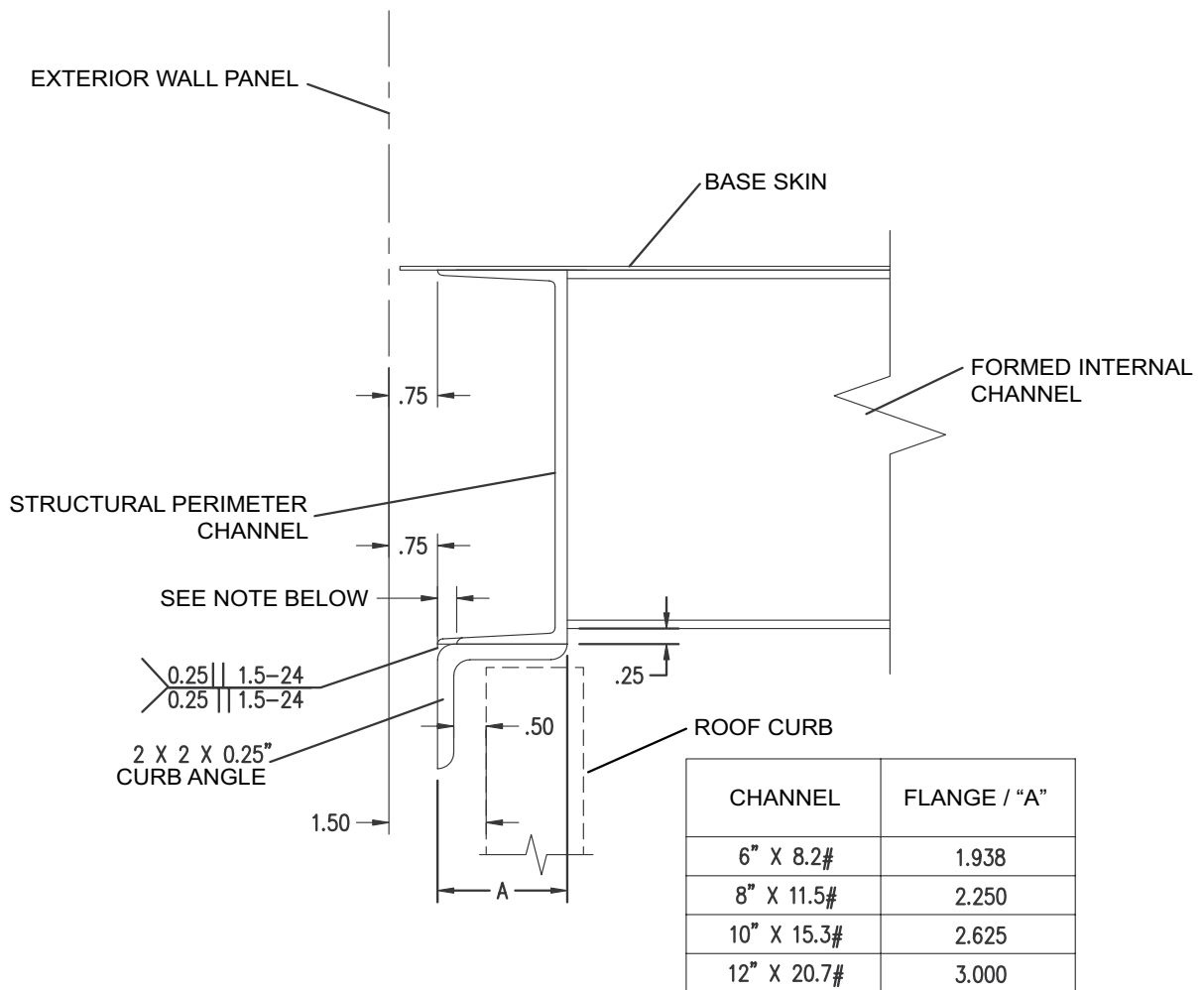

NOTE:
 Flange width can vary. Locate outside edge of curb angle using "A" dimension from the back side of the perimeter channel.

FIGURE 8 - ROOF CURB DETAIL

Clearance and Mounting for Indoor AHUs

It is recommended that the AHU is located in an air-conditioned space. Some suggested installations are shown in *Figure 9 on page 26*. Make sure the floor and housekeeping pads are flat and level.

Allow sufficient space around the AHU to remove the access panels and various parts. A minimum clearance equal to the width of the AHU plus 6 in. must be provided on one side of the AHU to remove the coil or fan assembly.

Concrete pads may not be as flat as they should be. Shimming and/or grouting may be necessary. Whether under the AHU base or curb, the AHU base needs to be on a flat plane.

Mounting Indoor AHU

Install the AHUs to provide enough elevation for properly designed condensation traps.

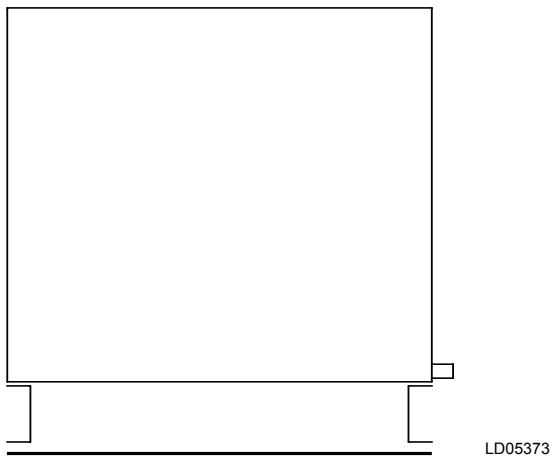

FIGURE 9 - NO HOUSEKEEPING PAD - BASE REQUIRED TO ACCOMODATE TRAP HEIGHT

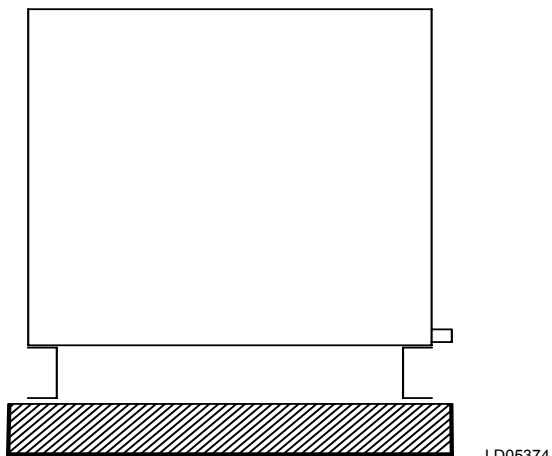
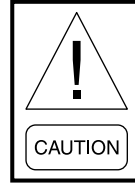

FIGURE 10 - WITH BASE AND HOUSEKEEPING PAD

Installing Ceiling Suspended AHUs



It is recommended that support is structurally engineered to prevent flexing, sagging or twisting of the AHUs.

Use the following instructions to prepare the site for ceiling suspended AHUs. Refer to *Figure 11 on page 27* for proper support in the direction of airflow and/or if the AHU is positioned perpendicular to the direction of the air flow.

Structure Positioned in Direction of Airflow

The AHU base must be supported continuously on both sides.

Structure Positioned Perpendicular to Airflow

The AHUs must be supported (at a minimum) at the following locations:

- Both ends
- At each shipping split, if applicable
- Upstream and downstream of each cooling coil segment
- Under heavy components like fans, attenuators, and heating segment.
- As a general rule, cross members should be placed every 96 in., in addition to each shipping split.

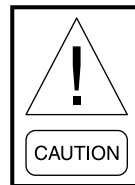

DO NOT obstruct the door operation, filter access, piping, electrical or control connections with suspension members.

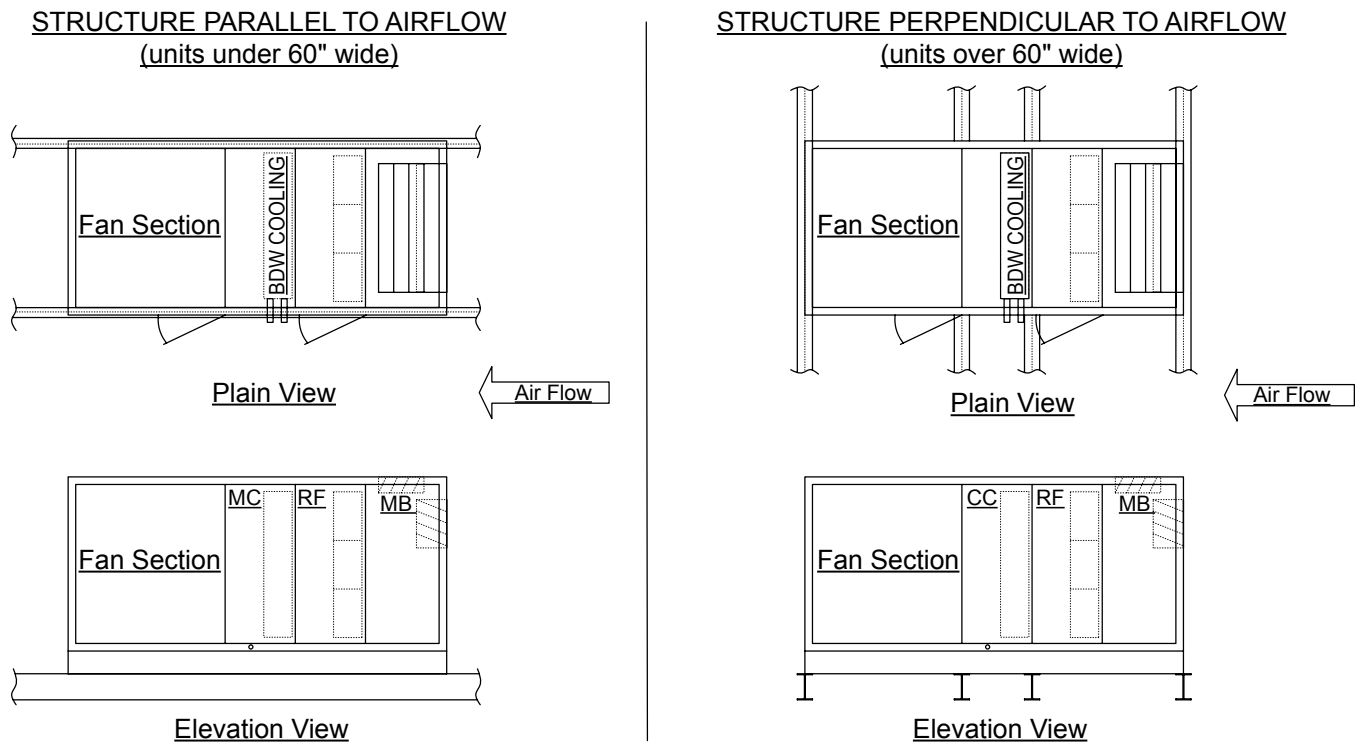

3

FIGURE 11 - CEILING SUSPENDED AHU

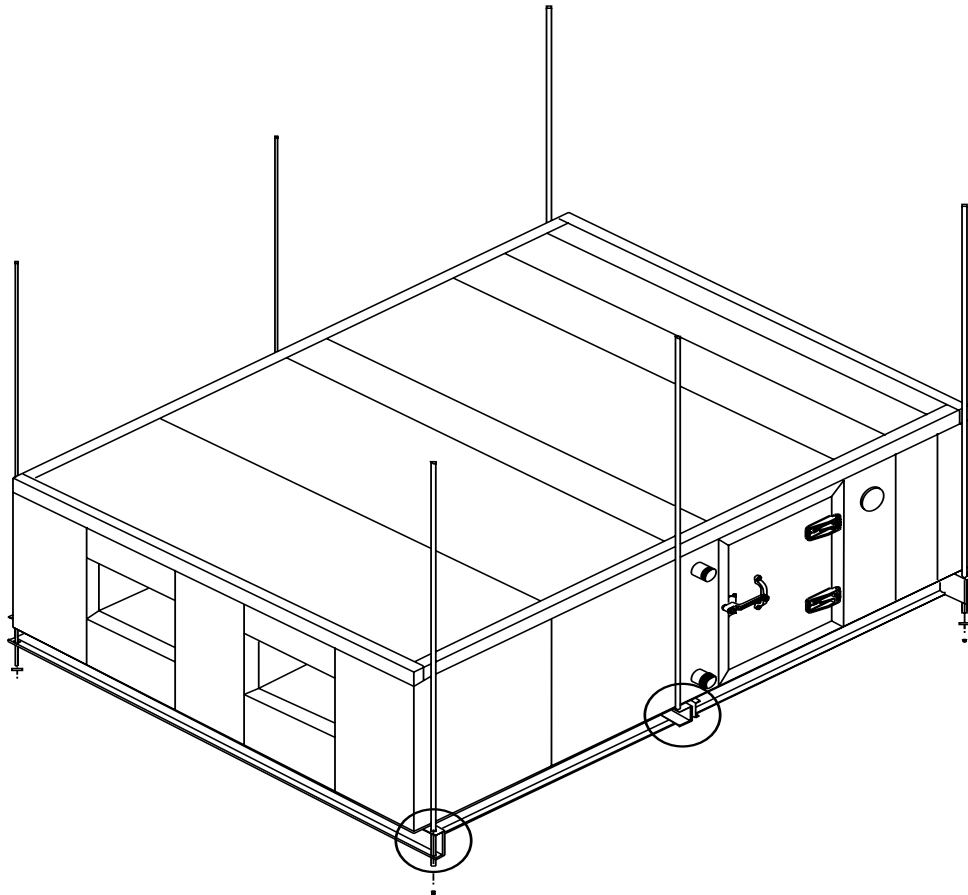

LD07941

FIGURE 12 - CEILING SUSPENDED UNIT

TOOLS REQUIRED TO INSTALL AHU

The following tools, which are not provided by Johnson Controls, are needed to install the AHU. Refer to *Figure 13 on page 28* for more information.

- Drill with adjustable torque
- No. 3 Phillips bit
- Allen wrench set
- Nut setter or socket set (1/4 in., 5/16 in., 3/8 in. and 9/16 in.)
- Wire cutters
- Come-a-longs (power pulls)
- Slings
- Pry bar
- Drift pins and awls
- Common hand tools
- Caulking gun
- Shackles

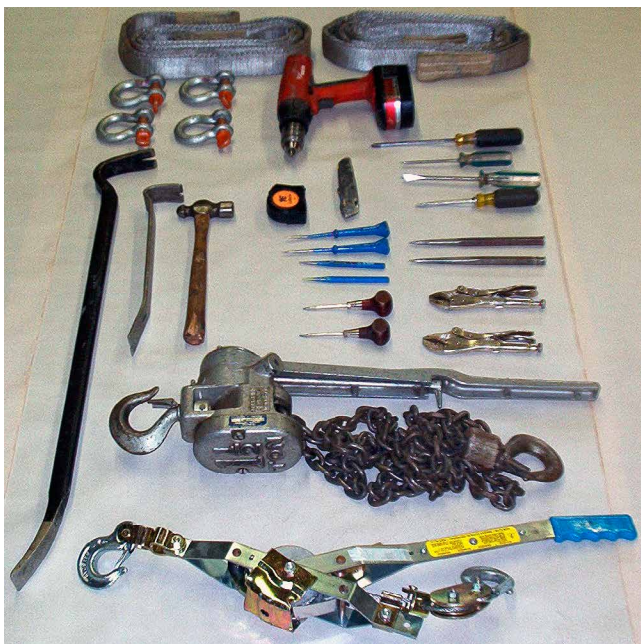

LD09613

FIGURE 13 - TOOLS NEEDED TO ASSEMBLE SHIPPING SPLITS

INSTALLING OUTDOOR AHU

Before installing the outdoor AHU, identify the loose parts.

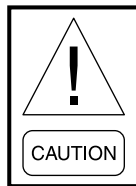

Do not damage the factory installed service vestibule, electrical cabinet, hoods, pipe stubs, door handles or roof overhang when installing the AHU.

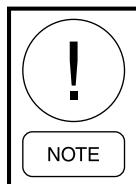

Verify that the actual outside dimensions of the assembled curb top are less than the inside dimensions of the bottom of the AHU.

Single Piece Outdoor AHU

Use the following instructions to install a single piece outdoor AHU.

1. Make sure the curb gasket, which is shipped with the curb package, is installed before the AHU is lowered onto the curb.
2. Lift the AHU from the ground onto the curb or support framework. Do not move the AHU onto a roof surface.
3. Remove the wood shipping material from the bottom of the AHU.
4. When setting the AHU onto the curb, make sure the installer positions a sealing gasket between the AHU and curb to provide a continuous airtight and watertight connection.

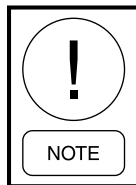

When installing the AHU on a steel frame or concrete slab, do not install a seal unless specified.

5. Install the AHU according to the International Building Code (IBC), NEC, state, and local codes.

INSTALLING THE YORK CUSTOM AHU

General

Units that are shipped in sections must be installed on a proper foundation and carefully assembled to provide the required unit performance.

- Johnson Controls Custom units are assembled in one piece in our factory, and then, split prior to shipping.
- Johnson Controls Custom units must be level for reassembly.
- All bolts, nuts, washers, split covers, and polyurethane caulking (if required) can be found in supply fan section.
- All splits are labeled with letters (e.g., A-A, B-B) to indicate which sections are to match up for reassembly.

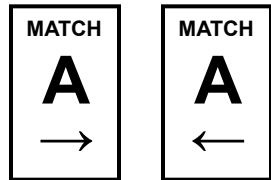

REMOVABLE LIFTING LUGS

If your unit is wider than any split section's airway length, you will be provided with removable lifting lugs along the width of unit. Once the splits have been placed as close as possible to each other, remove the inner lifting lugs. A hand-actuated winch, or come-along, can be used to bring the unit sections closer together for final bolting. Attach hand winch or come-along to base "tie down tubes" to bring unit together.

ELECTRICAL WIRING/PIPING

It is the installer's responsibility to reconnect all internal and external electrical or piping splits. All wires are colored and/or numbered to designate which wires should be joined at each split. Before turning on power, check all electrical circuits for continuity.

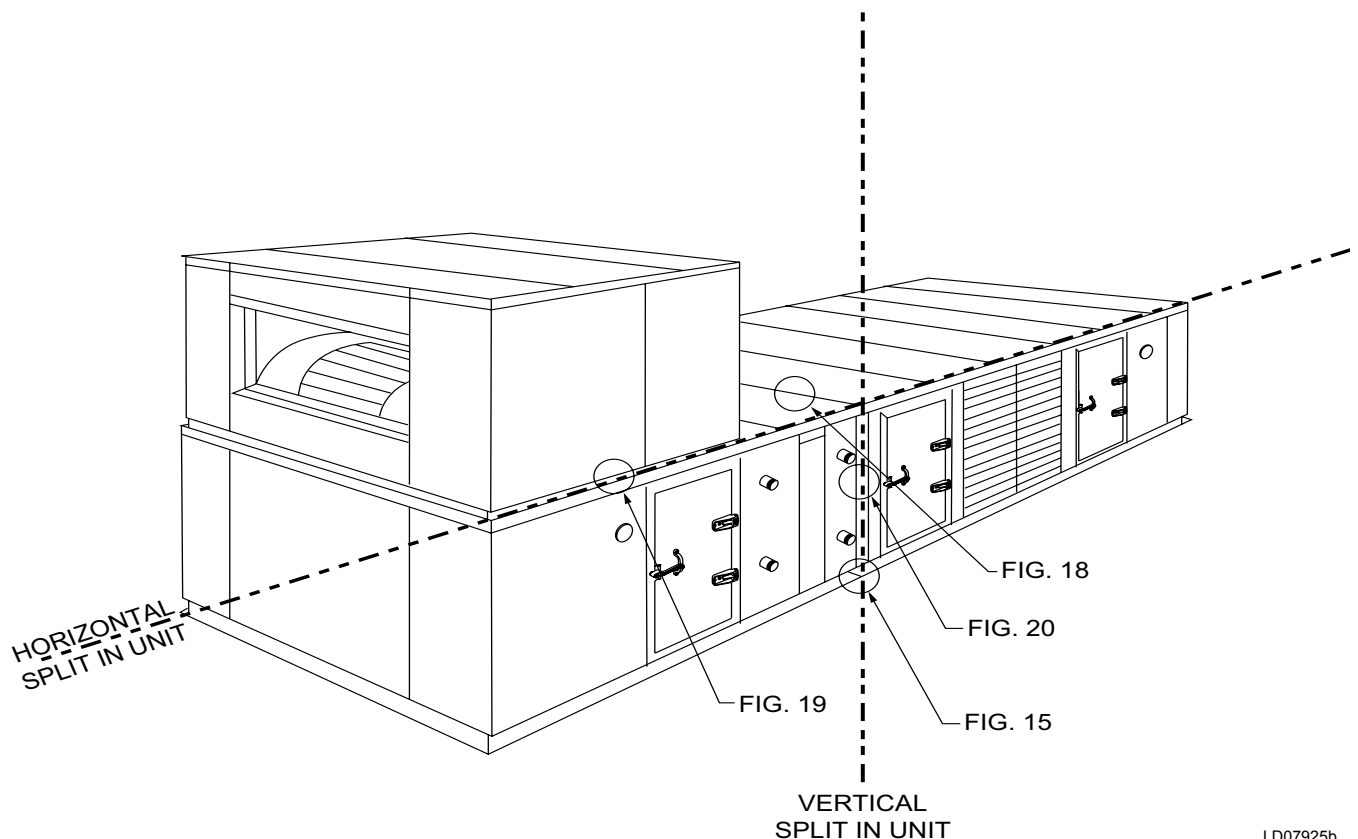

FIGURE 14 - TYPICAL CABINET SPLIT

LD07925b

REASSEMBLY PROCEDURE FOR VERTICAL SPLIT UNIT

1. Position sections on level surface.
2. Apply polyurethane caulk where shown on both sides of split and bolt base together.
3. Attach hand winch to base "hold down tubes" and pull split section together. Bolt base per *Figure 15 on page 30*.
4. Split seams that have internal access to both sides of split will be reattached with bolts and nuts. Split seams with internal access to only one side of split will have cage nuts on the blind side and bolts installed from accessible side. All bolt holes require a bolt.
5. If bolt holes do not align, it may be due to racking during transit to job site. Use jack to lift one side until holes on the wall of the opposite side align. Bolt this wall together and then remove jack from opposite side. As the unit settles, the out-of-square racking caused during transit should realign. Continue assembly with bolting other side, base, floor and roof, making use of a drift pin to align the holes. Bar clamps may be needed to align the roofs together. If bar clamps are needed use wood for protection in between the bar clamp and unit.

6. Check to see if all bolts are secured properly, and apply polyurethane caulk to all exterior seams per *Figure 15 on page 30*.
7. Drive screw or bolt floor flange together.
8. CHECK all splits to see if polyurethane caulk was applied and split was bolted properly.
9. CHECK all splits to see if all electrical and piping connections are complete and correct.

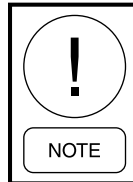

Temporary roof supports and diagonal (shipping) supports should not be removed until the split sections are completely reassembled.

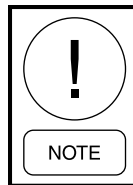

Outdoor Custom units that have an SQ for roof coating applied where light foot traffic is permitted, but storage of materials typically found on construction sites are not permitted to be placed on roofs. Care must be taken not to damage the roof coating.

If other than light foot traffic or storage of materials becomes necessary, plywood may be placed on the roof provided the weight applied does not exceed 50lbs. per sq. ft.

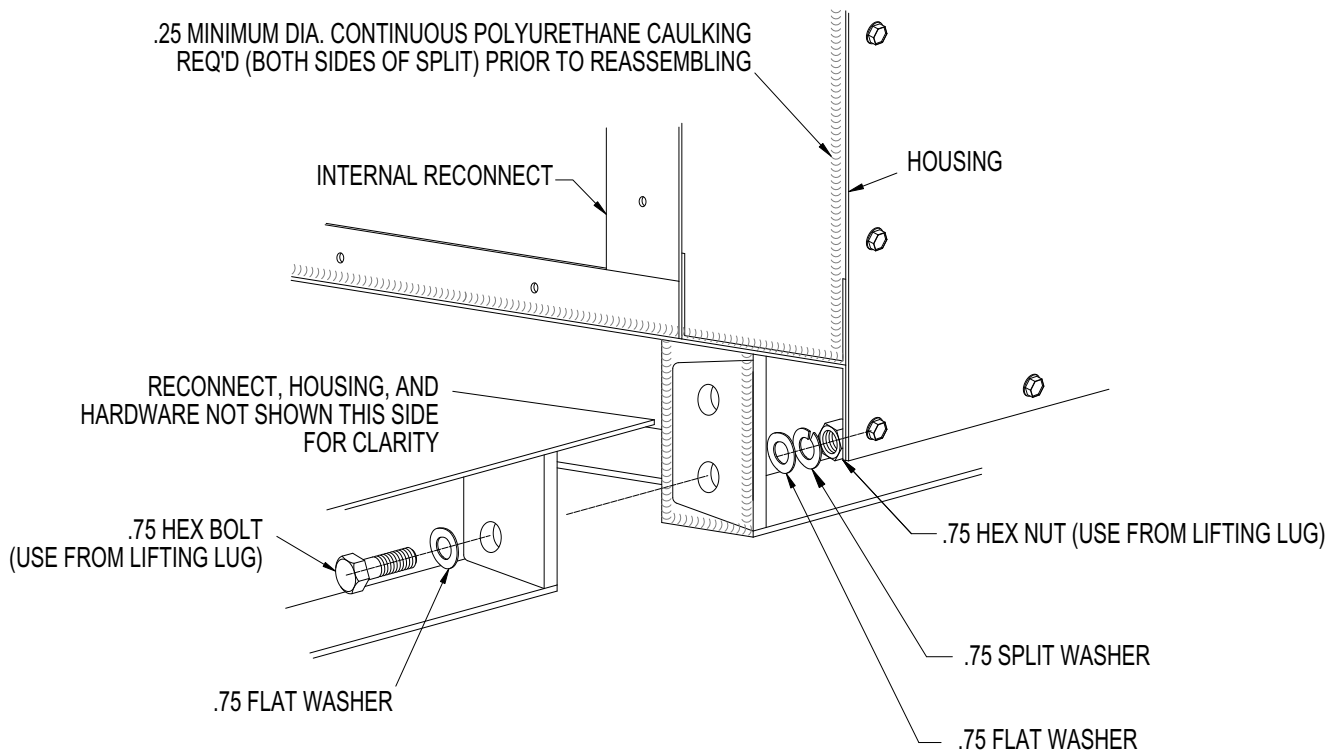

LD07926A

FIGURE 15 - BASE ASSEMBLY ATTACHMENT

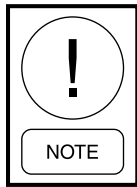

Only use caulking shipped with unit.

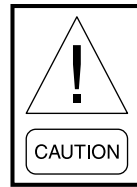

Do not use silicone caulking on field re-connects or on shipping split covers.

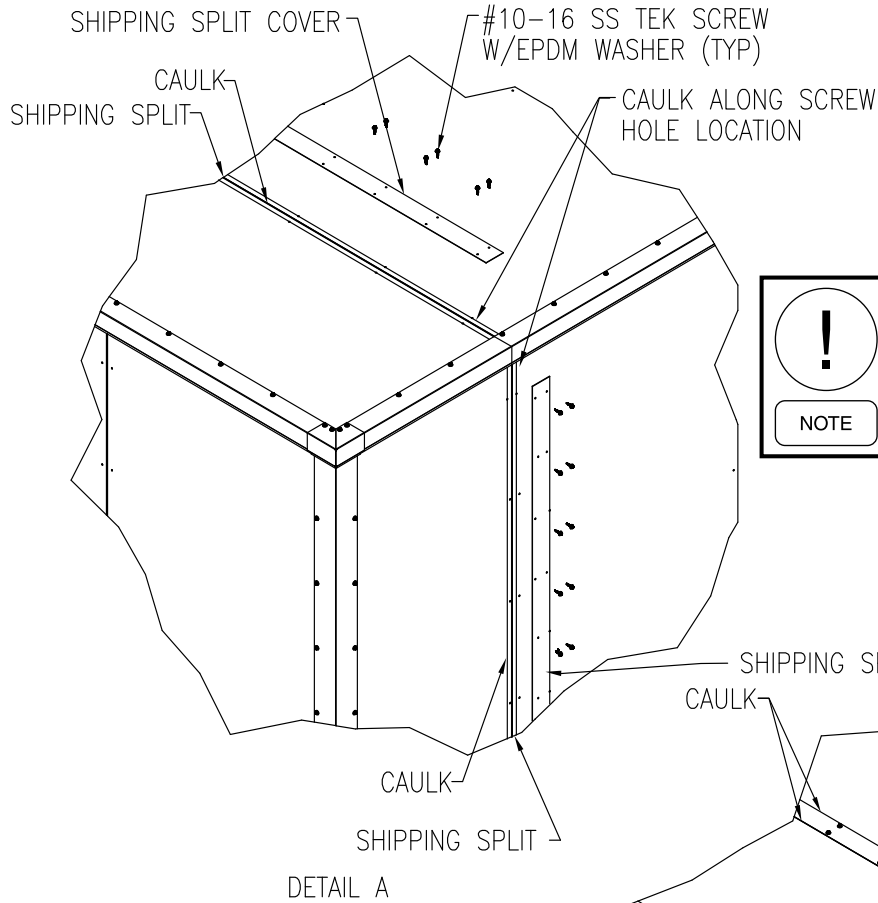

Shipping split covers ship with the air handler installed to one side of the reconnect. Remove cover and install across the split as shown on Detail A and B.

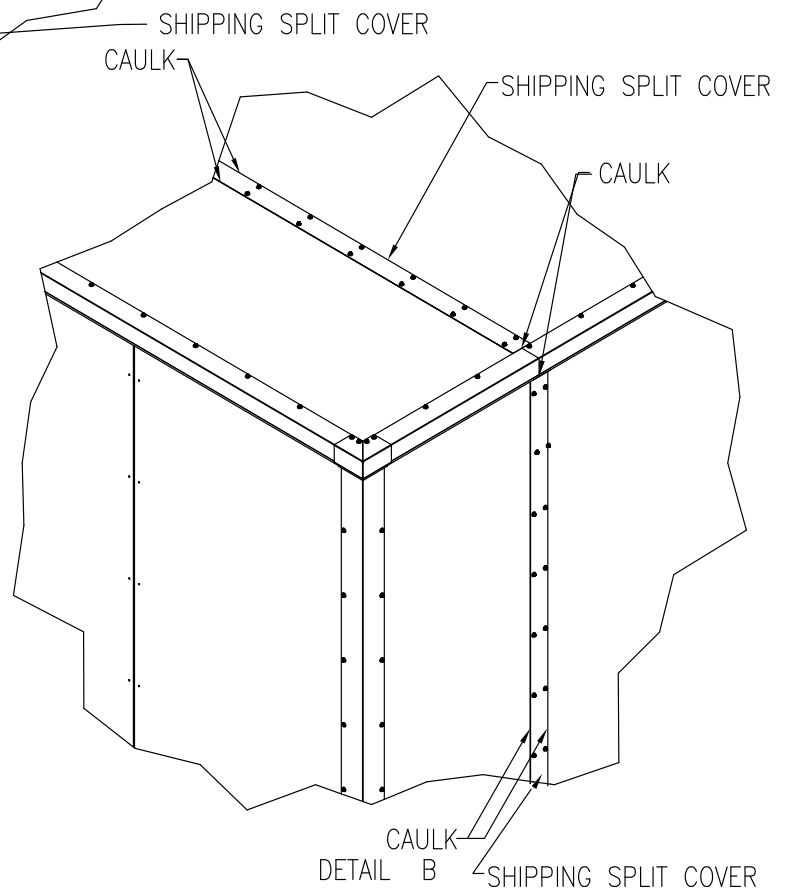

Acceptable Polyurethane Caulking:
 Manus-bond, Gray, P/N 013-02966-001 or
 Sikaflex, Gray, P/N 013-03317-050 or
 Sikaflex, Champagne P/N 013-03317-040

FIGURE 16 - SPLIT REASSEMBLY PROCEDURE FOR OUTDOOR UNITS ONLY

LD13129

RECONNECTION INSTALLATION PROCEDURE:

1. Apply a generous amount of polyurethane caulking to the face of the housing and split plate as shown.
2. Pull sections together from the base split plate until they meet.
3. Clamp off bottom leg of reconnect until no gaps are visible.
4. Install reconnection hardware starting from the middle of the bottom angle working around to the middle of the top angle, making use of a drift pin to align the holes. Bar clamps may be needed to align the roofs together. If bar clamps are needed use wood for protection in between the bar clamp and unit.
5. Once unit sections have been joined, contractor to seal the exterior and interior reconnect seam with polyurethane caulk.

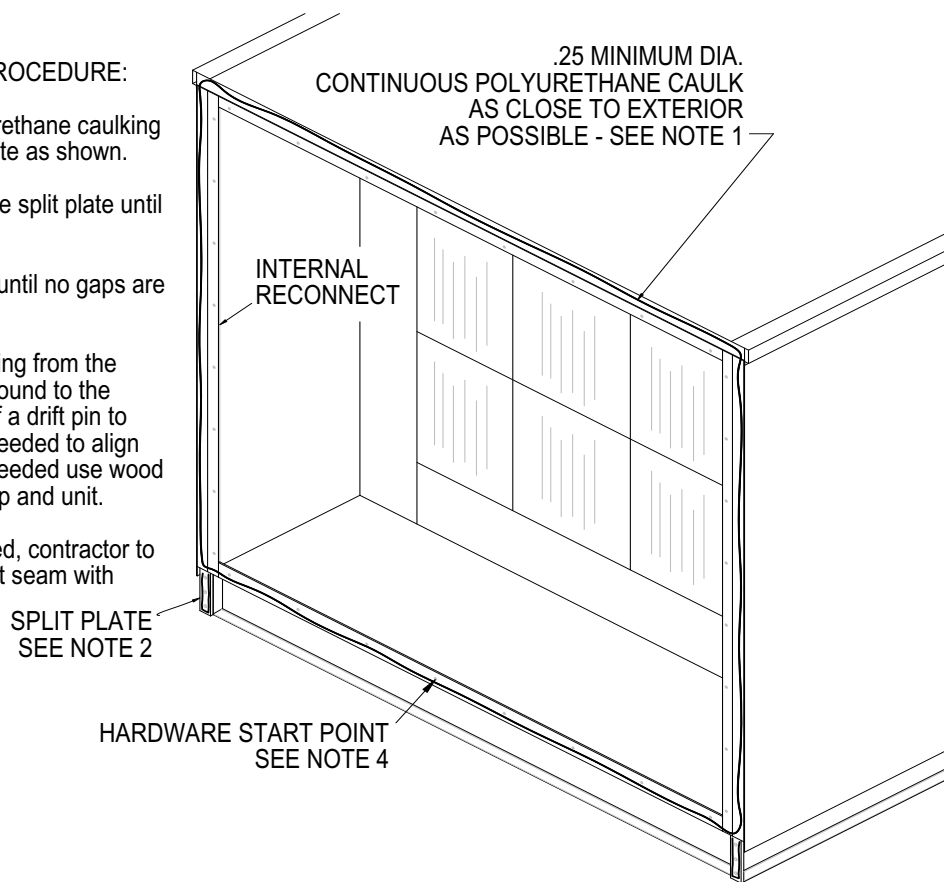

LD07932A

FIGURE 17 - SPLIT REASSEMBLY PROCEDURE**OUTDOOR SPLIT ROOF SEALANT PROCEDURE**

1. The mechanical joint between sections must be bolted and sealed with polyurethane caulking.
2. Acu-Shield Roof Coating can be applied after polyurethane caulking is dry and when surface temperature is between 45 and 108 degrees. Below 45 degrees, extra steps must be taken to keep the polyurethane caulking, acu-shield, and metal reconnect surfaces heated for proper application during installation. Contact Product Service for further direction.
3. Do not apply when inclement weather is imminent within a 24 hr. period.
4. Do not apply to wet, ice, or snow covered surfaces.
5. Before applying, clean surface with wire brush or solvent wipe (not provided).
6. Apply Acu-Shield Roof Coating with 3" wide roller or 3" wide paintbrush (not provided).
7. One quart applied at 45 mils is equal to a 3 inch wide X 33 ft. long section.
8. Cure time will vary with temperature and humidity. Under normal conditions, a rubber coating can be expected within a 24 hr. period.

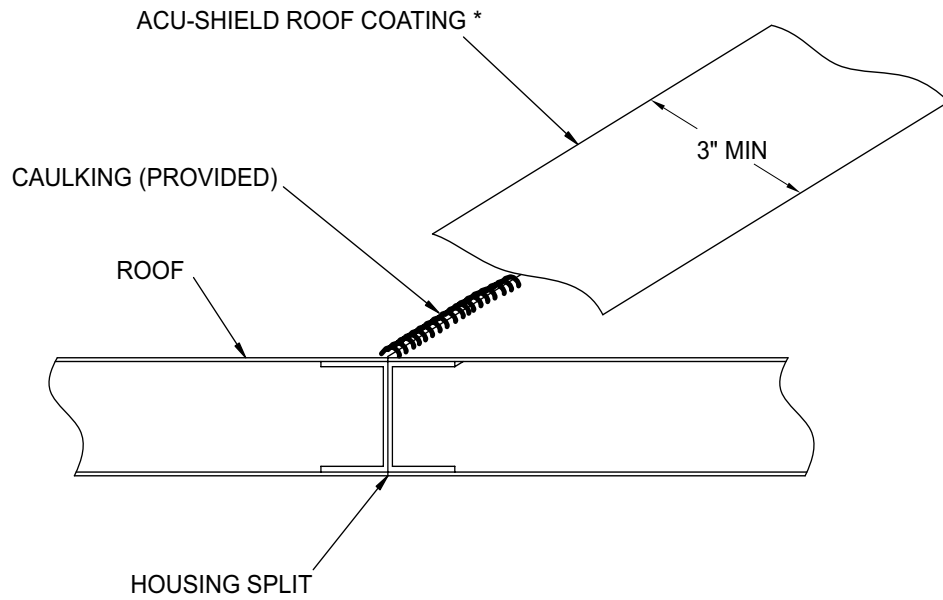

* Provided with ship loose items in fan section (see table in Section 2 "Receiving & Inspection").

LD07933B

FIGURE 18 - OUTDOOR SPLIT SEALANT PROCEDURE ON ROOFS WITH ACU OPTION

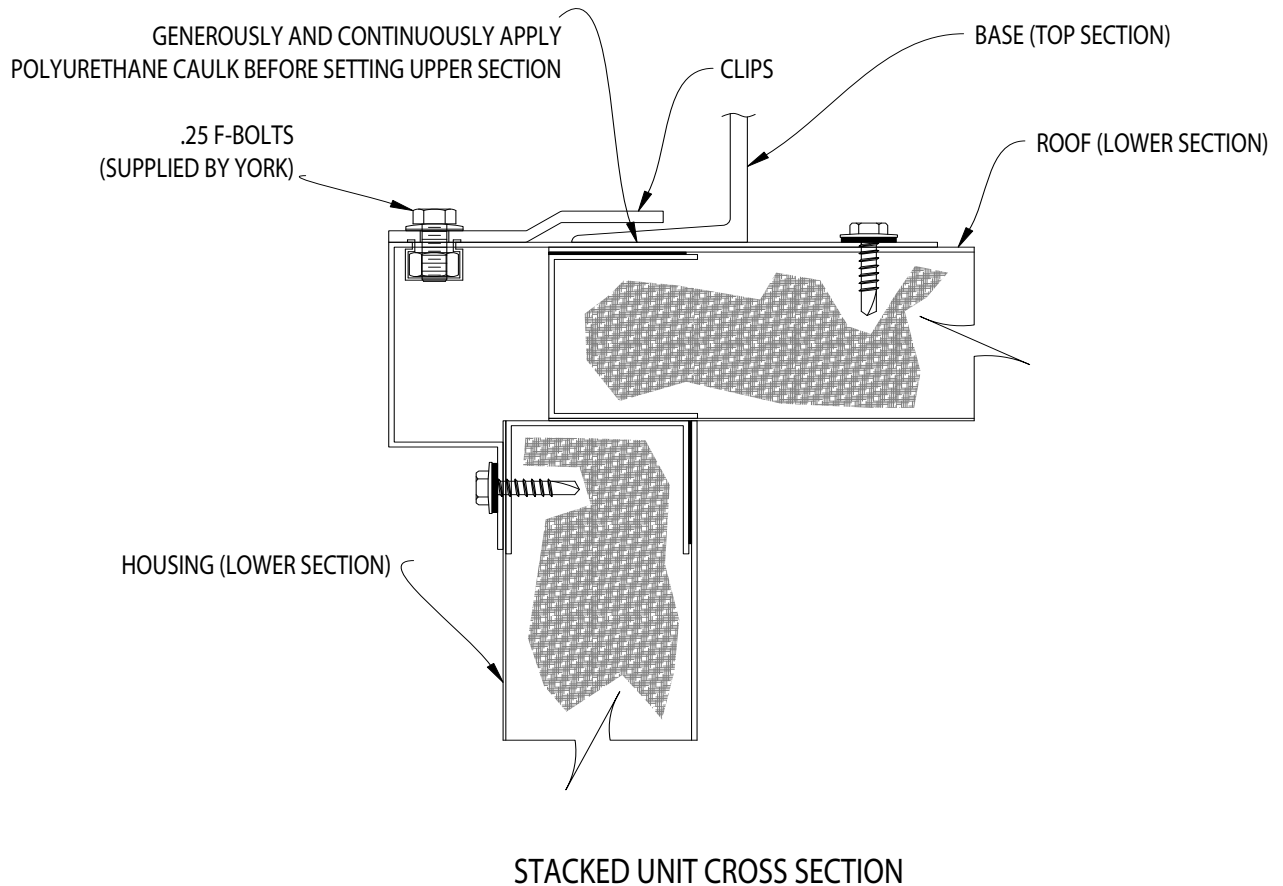

STACKED UNIT CROSS SECTION

LD010140

FIGURE 19 - HORIZONTAL SPLIT

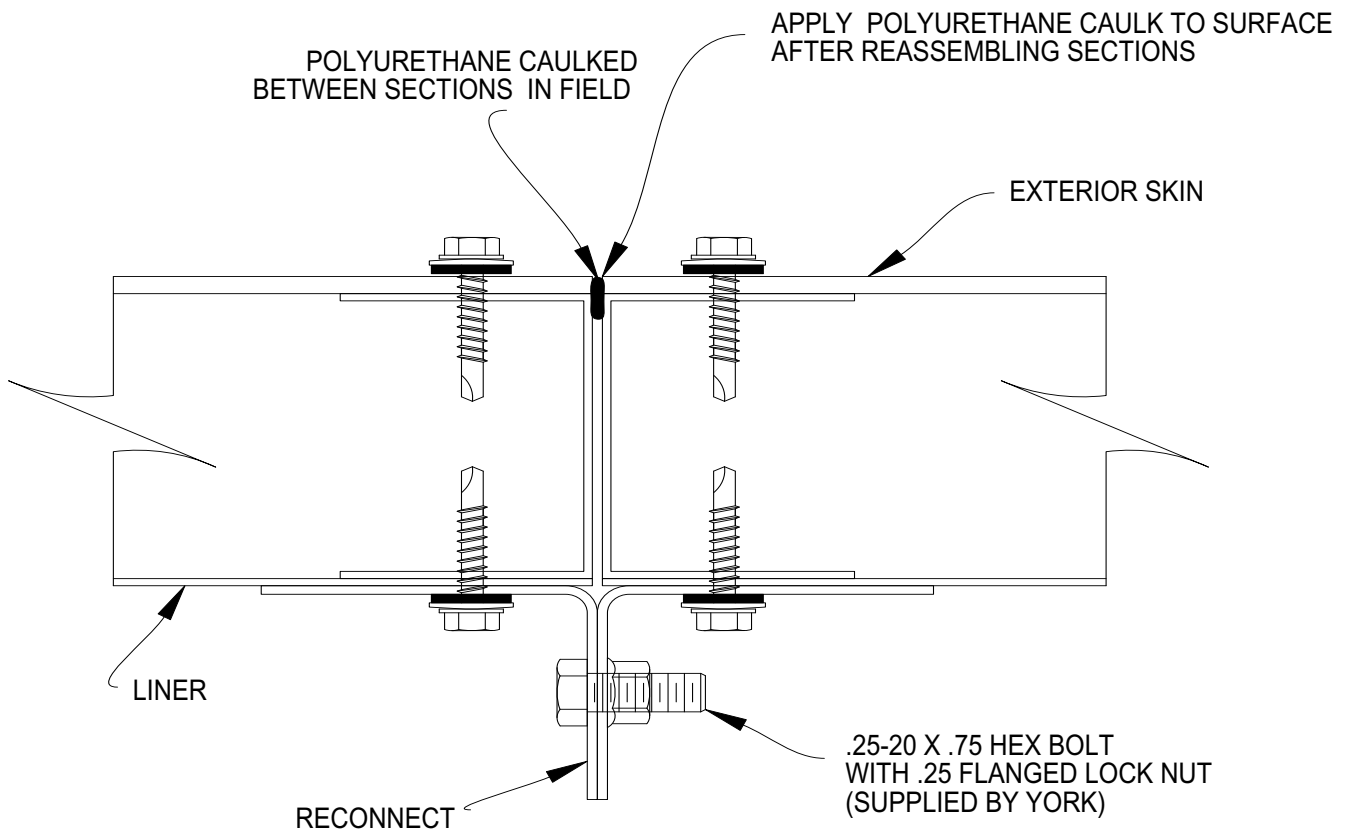

LD010141

FIGURE 20 - CROSS SECTION OF SPLIT WALL ASSEMBLY

THERMAL BREAK RECONNECTION INSTALLATION PROCEDURE:

1. APPLY A GENEROUS AMOUNT OF POLYURETHANE CAULKING TO THE FACE OF THE RECONNECTION FLANGE AND SPLIT PLATE AS SHOWN.
2. CONTRACTOR TO INSTALL GASKET BEFORE JOINING SECTIONS. GASKET TO BE SHIPPED LOOSE.
3. PULL SECTIONS TOGETHER FROM THE BASE SPLIT PLATE UNTIL THEY MEET.
4. CLAMP OFF BOTTOM LEG OF RECONNECT UNTIL NO GAPS ARE VISIBLE.
5. INSTALL RECONNECTION HARDWARE STARTING FROM THE MIDDLE OF THE BOTTOM ANGLE WORKING AROUND TO THE MIDDLE OF THE TOP ANGLE, MAKING USE OF A DRIFT PIN TO ALIGN THE HOLES. BAR CLAMPS MAY BE NEEDED TO ALIGN THE ROOFS TOGETHER. IF BAR CLAMPS ARE NEEDED USE WOOD FOR PROTECTION IN BETWEEN THE BAR CLAMP AND UNIT.
6. ONCE UNIT SECTIONS HAVE BEEN JOINED, CONTRACTOR TO SEAL THE EXTERIOR AND INTERIOR RECONNECT SEAM WITH POLYURETHANE CAULK.

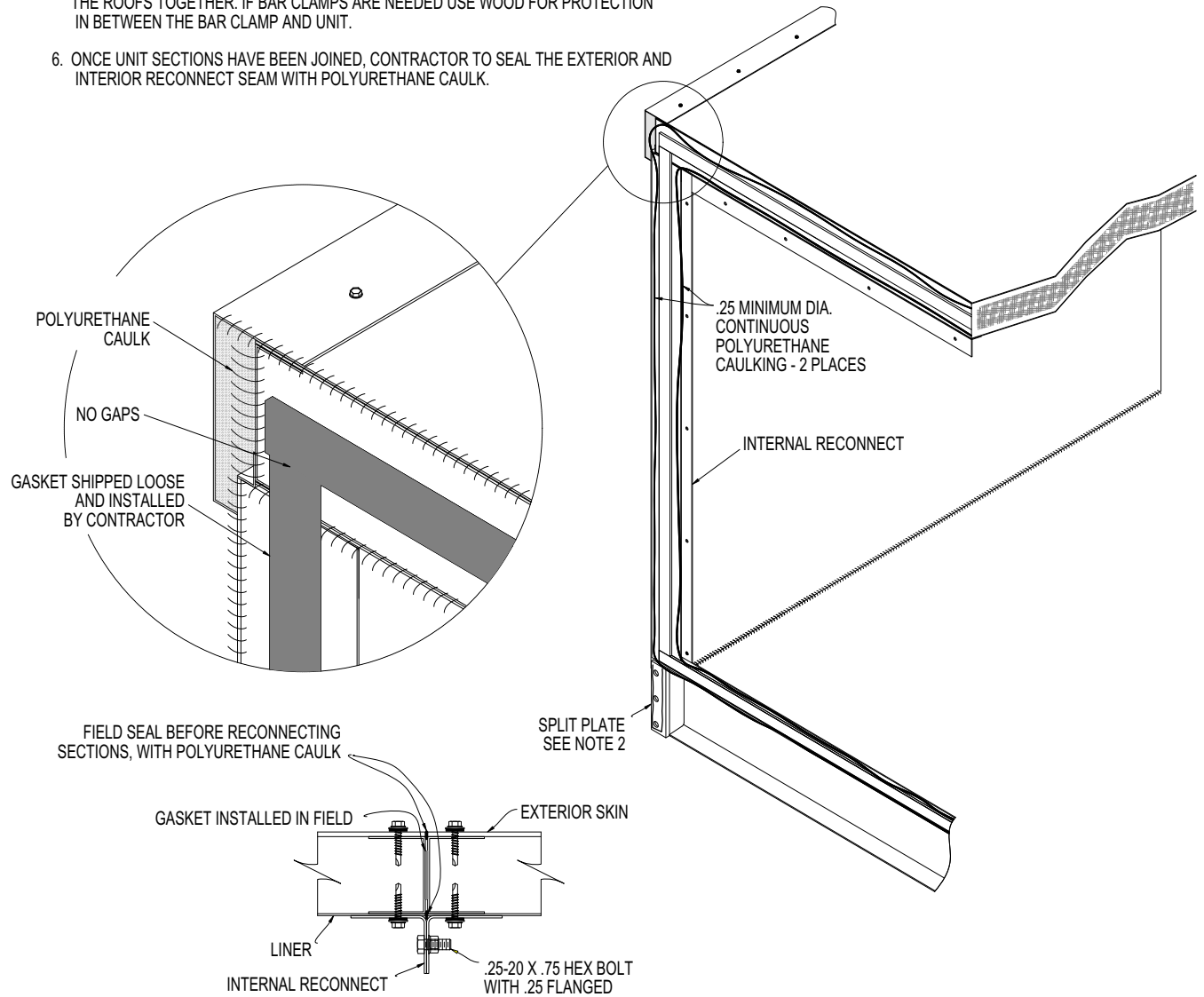

LD07931A

FIGURE 21 - MULTI-SECTION GASKET INSTALLATION ON THERMAL BREAK UNITS

Installing Hood with Moisture Eliminators

1. Identify the correct hood and its respective location by looking at the label as shown in *SECTION 2 - PRODUCT DESCRIPTION* in this manual.
2. Correct orientation is with the tracks or bird screens to the bottom. The mounting flanges are pre-drilled.
3. Each hood is fitted with a factory installed bird screen unless the moisture eliminator option is selected.
4. Apply the Butyl tape to the pre-drilled hood flanges and back wall angle that contact the AHU panels.
5. Use the hex head screws with the EPDM washer provided in the fastener pack.
6. Completely cover each damper opening in the AHU panels by its respective hood. The bottom of the hood should extend approximately 6 in. below the AHU panel opening.
7. Center each hood over the width of the opening. All hoods, especially those containing barometric dampers, **MUST** be installed square.
8. Seal each hood gutter to the AHU panel with the polyurethane caulk (provided).
9. When multiple hoods are installed in a stacked space, the hoods should be approximately 1 1/2 in. apart so that the bottom hood will extend 6 in. below the bottom of the opening.
10. If equipped, install the optional moisture eliminators as shown in *Figure 22 on page 36* using the following instructions.
 - a. Remove the clip(s) from the leading edge of the hood.
 - b. Insert the proper size moisture eliminator or filter into the tracks.
 - c. Reinstall the clip(s) on the leading edge of the hood.

Outdoor Air Temperature and/or Humidity Sensors

When outside air hoods are shipped loose with AHUs that include factory packaged controls, these sensors will be dismantled and pulled back into the AHU. The contractor should find them secured with tape inside, and put them through their respective penetration to the exterior, and mount them to the bracket provided.

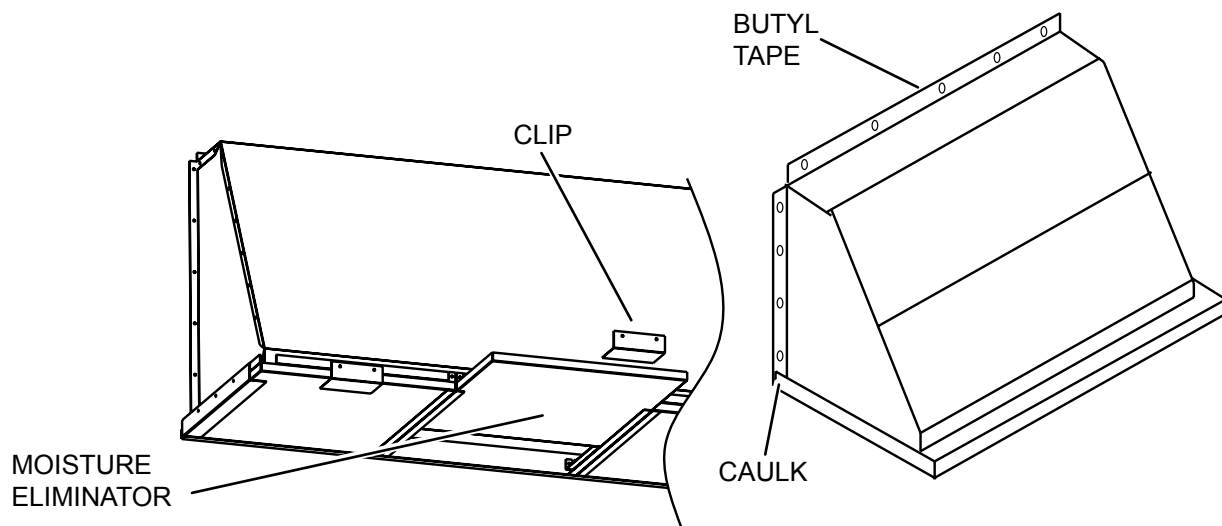

LD13783

FIGURE 22 - INSTALLING HOOD WITH OPTIONAL MOISTURE ELIMINATORS

Installing Damper Actuator

Use the following instructions to install the actuator as shown in *Figure 23 on page 37*.

Damper Blade Orientation

Return air and mixing dampers:

Position blades so that they will be open once the actuator is installed. This will be the dampers spring return position. Note whether the damper shaft is rotated fully clockwise or counter clockwise.

Outside air and exhaust air dampers:

Position the damper blades so that they will be closed once the actuator is installed. This will be the dampers spring return position. Note whether the damper shaft is rotated fully clock-wise or counter clockwise.

Actuator Installation

1. Remove the bearing plate from the damper frame and jackshaft.
2. Slide the damper actuator onto the open end of this shaft making sure that the proper spring return position on the face of the actuator matches the damper shafts rotation, if not then reinstall the actuator with it flipped over.

3. Reinstall the bearing plate to the damper frame and jackshaft.
4. Slide the damper actuator, mounting bracket into the actuator mounting grooves and fasten to the damper frame using self drilling screws.
5. Securely tighten the actuator shaft clamp to the dampers jackshaft. Make sure at this point the damper shaft is completely rotated to its proper position.
6. Manually operate the actuator to its fully actuated position using the crank arm provided with the actuator then release the spring to allow the damper to go back to its original position. This will verify the actuators spring rotation and stroke.
7. Set the damper actuators rotation selector switch to the proper rotation required to actuate the damper.

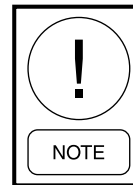

This will always be opposite the spring return rotation.

VENDOR	YORK PART NUMBER	BRACKET PART NUMBER
Belimo	025-25737-001	086-00138-014
	025-25737-002	086-00138-014
JCI	025-39114-001	086-00138-013
	025-39114-002	086-00138-013
	025-39115-001	086-00138-016
	025-39115-002	086-00138-016
	025-39116-001	086-00138-014
	025-39116-002	086-00138-014
	025-39117-001	086-00138-014
	025-39117-002	086-00138-014

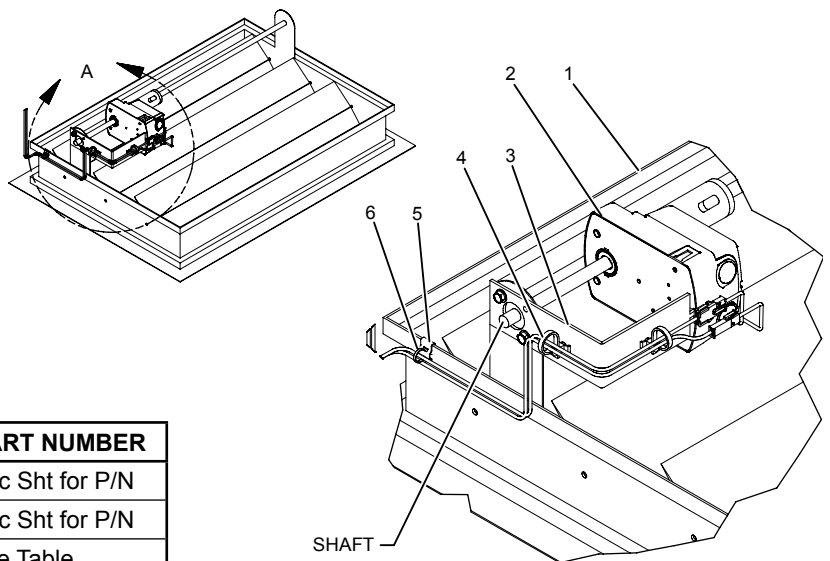

ITEM	DESCRIPTION	YORK PART NUMBER
1	Damper	See Spec Sht for P/N
2	Actuator	See Spec Sht for P/N
3	Actuator Mounting Bracket	See Table
4	7.8" length, 0.25" hole, black 6.6 nylon	025-40605-001
5	Edge Clip # MCMS12-P-C	025-39067-002
6	Cable Tie 7.9: LG	025-39031-002

FIGURE 23 - INSTALLING THE DIRECT COUPLED ACTUATOR

LD17268

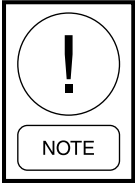
Installing Multi-Zone (MZ) Dampers

If the MZ segment has a shipping split, a rear discharge at the end of the AHU, and a MZ damper, the damper will be shipped loose.

1. Identify the gaskets and hardware needed for installation.
2. After the AHU top tier is assembled to the bottom tier and sealed, install the MZ damper assembly, which includes the hot (top) deck and cold (bottom) deck damper banks that are already connected at each blade as shown in *Figure 24 on page 38*.

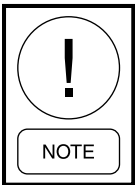

Distortion will result in unreliable blade operation.

3. Remove the 16-gauge shipping plate, which is located between the hot and cold decks from air entering side only.
4. Apply the neoprene gasket to the mounting flanges of the damper assembly.
5. Center the damper assembly over the discharge openings of the hot and cold decks.
6. Attach the damper assembly to the AHU's outer perimeter mounting flange, using the screws provided.
7. Remove the 16-gauge shipping plate from the air leaving side.
8. Install the screws through the mounting flanges between the hot and cold decks.

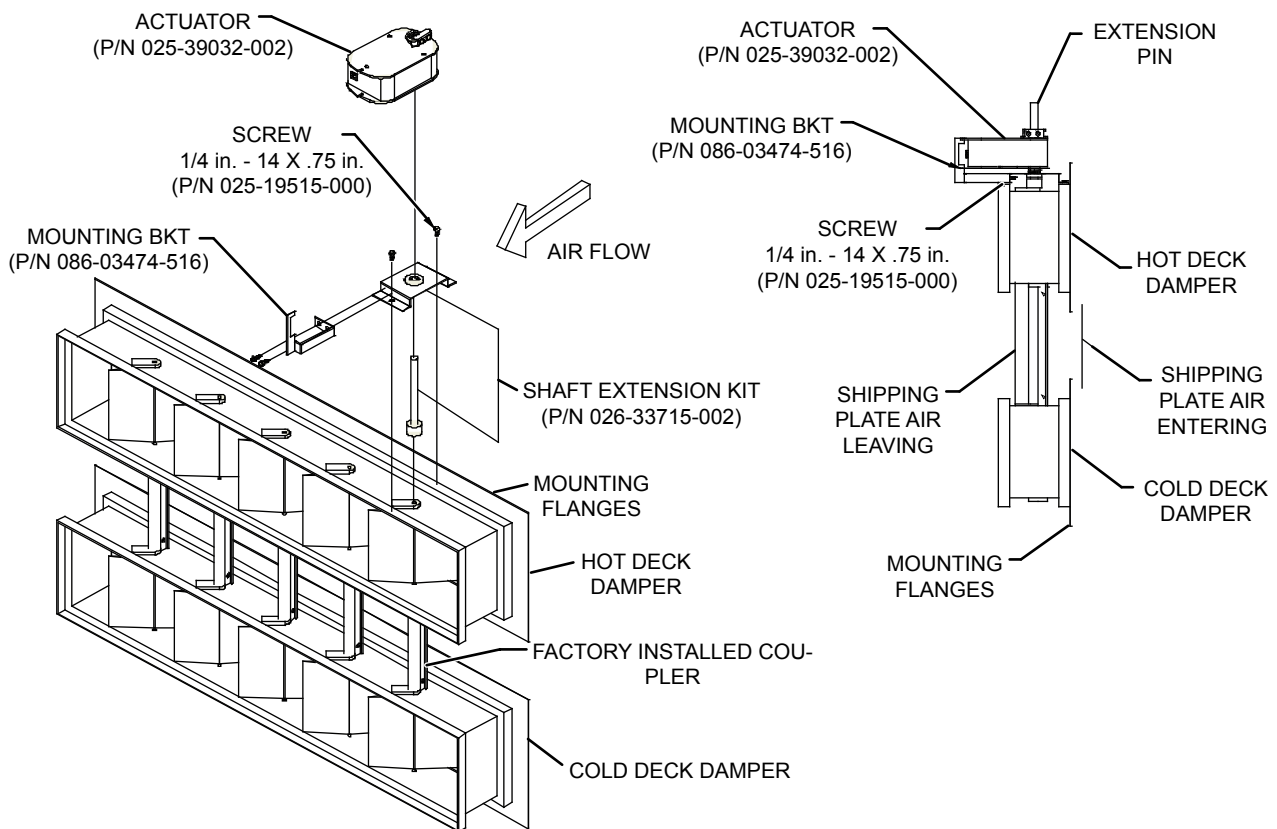

LD12029a

FIGURE 24 - INSTALLING MZ DAMPER

Installing Field Supplied MZ Damper Actuators

When the actuators are field supplied for MZ dampers, use the following information to select the correct size actuator.

- Required torque is 7 in-lb/sq. ft of damper area up to 2500 feet per minute (FPM).
- Damper blades are 6 in. wide and vary in height.
- Calculate the torque by the number and size of blades in each zone. There are hot deck blades directly connected to cold deck blades.
- Determine the number of blades per zone by the system cubic ft per minute (CFM), and static pressure requirements for each zone by the engineer's construction documents.
- Cut the blade linkage (flat rods) connecting all blades of each deck at the appropriate places to divide the decks into correct size zones. These rods are mounted externally on the assembly. Make sure to cut out a section of the flat connecting rod, which will prevent interference when the zones modulate in opposite directions.
- One damper shaft extension kit (P/N 026-33715-002), as shown in *Figure 25 on page 39* is provided for each zone per the factory order form.

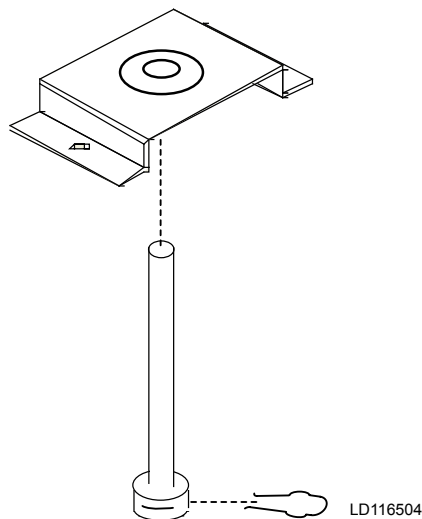

FIGURE 25 - DAMPER SHAFT EXTENSION KIT (P/N 026-33715-002)

- The contractor should supply the actuators and mounting brackets. The part numbers are available upon request.

- On the rear mount (discharge through end of the AHU), always mount the actuators on the top of the upper deck.
- Do not allow the duct insulation to restrict the damper blades or external linkage.
- Direct coupled actuators are recommended.
- Make duct connections at the zone dividers without restricting the damper blade(s).

BACK DRAFT DAMPERS FOR DUAL FANS AND FAN ARRAYS

The counterbalance is locked into place for shipping as shown in *Figure 26 on page 39*. Before startup, the counterbalance will have to be released. To do this, loosen the set screws and slide the counterbalance off the end of the shaft. Flip the counterbalance and slide it back on the shaft. Rotate the counterbalance above the damper as shown in *Figure 27 on page 39*, and then tighten the set screws. The counterbalance should be free to rotate.



FIGURE 26 - COUNTERBALANCE LOCKED INTO PLACE FOR SHIPPING



FIGURE 27 - COUNTERBALANCE UNLOCKED FOR START-UP

FILLING INERTIA FAN BASE

Inertia fan bases are pre-engineered according to the fan and motor size. Use the following instructions to fill an inertia fan base with concrete.

- Calculate the amount of concrete by measuring the overall length and width of the fan base assembly cavities that have the corrugated metal bottoms. The standard depth of a cavity is 4 in.
- Fill each cavity to the top with wet concrete. Do not get concrete mix on the bolts and adjusting parts of the adjustable motor base, sheaves, belts, or on the floor under the edges of the isolated fan base.

STEAM HUMIDIFIER

If purchased, steam humidifiers are provided with factory mounted dispersion equipment inside the AHU. The steam injection or generating equipment, metering devices, and sundries are shipped loose with the AHU. Humidifier manufacturer's installation, operation and maintenance information is packaged with the humidifier. The installing contractor(s) is responsible for supplying all required steam supply and condensate piping, and wiring.

UVC EMITTER LAMPS

If purchased, the contractor is responsible for installing the UV lamps, and connecting a 120 volt power supply as shown in *Figure 28 on page 40*. The Johnson Controls factory provides the following pre-wired parts.

- Internal wiring with a magnetic door safety switch.
- A lockable disconnect switch with a *Press to Test* pilot light.
- A latching circuit that has to be manually re-energized on the AHU's exterior after a door has been opened and closed.



Use clean cotton rags, clean jersey or latex gloves to handle the lamps. DO NOT touch UV lamps with bare hands or leather gloves because the oil will damage the lamps.

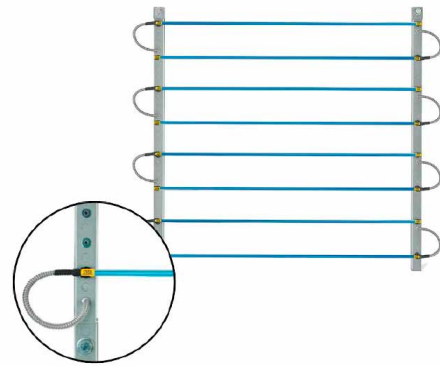

V_Max

FIGURE 28 - V-MAX GRID LAMPS

Two Types of Lamps

Three different types of UV lamps are used in AHUs: V-Mod and V-Max Grid.

V-Mod Lamps - Install the two-pronged lamps into the slotted fixtures as shown in *Figure 29 on page 40*, then rotate the lamp 90°.



LD16551

FIGURE 29 - INSTALLING V-MOD LAMP

V-Max Grid Lamps - Fit the four-pronged lamp into the clamp mounted on the UV segment where a pigtail is installed. Insert the prongs into the pigtail plug.



LD16552

FIGURE 30 - INSTALLING V-MAX GRID LAMPS

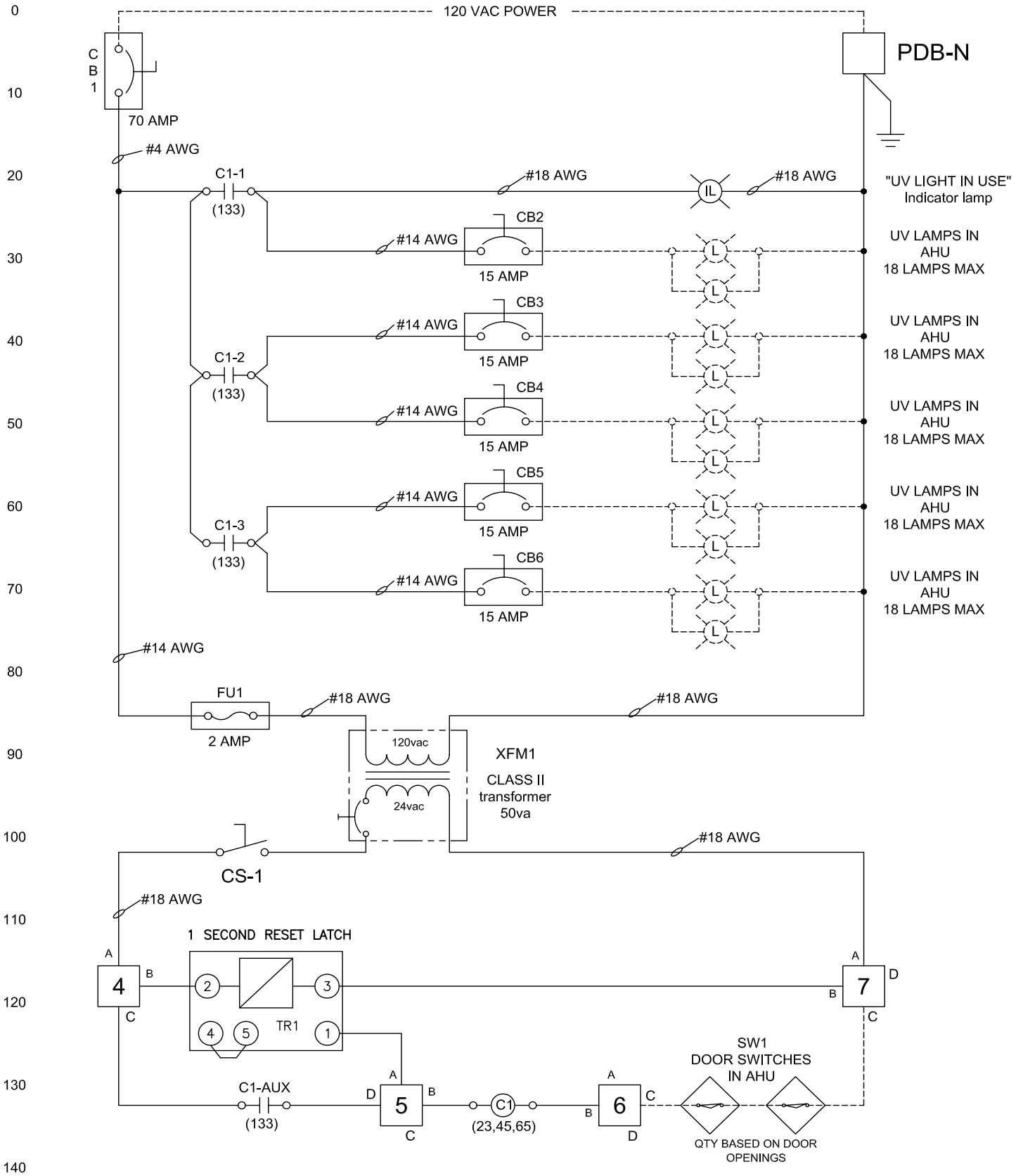
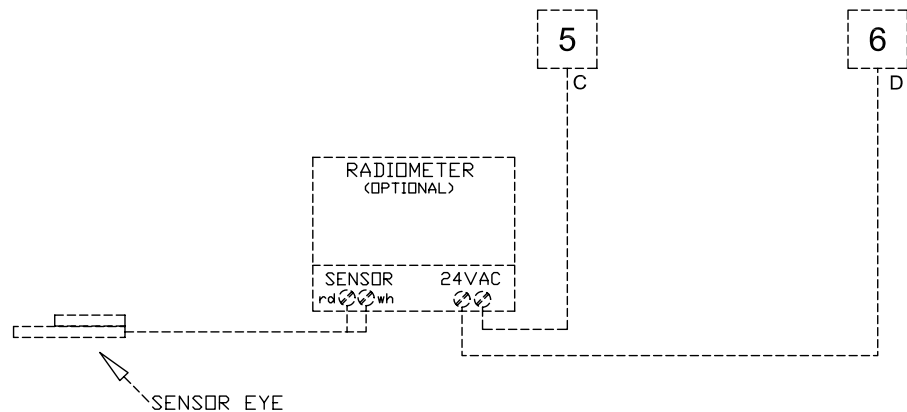

FIGURE 32 - UV CONTROL PANEL WIRING (GREATER THAN 8 AMPS)

OPTIONAL RADIOMETER WIRING.



Sequence of Operation:

Disconnecting Means of UV lighting will be accomplished by "CB1" internal to the panel. "CB1" is cable of being locked out by panel latching mechanism.

"SW1" is a proximity switch with a magnet, which will close a set of normally open contracts. The magnet will engage the "SW1" contact whenever it is within 1/2" of the switch.

"TDR1" is one second (1sec) time delay relay having normally open contacts. When power is initiated, its contacts will close for one second then re-open. To reset, power, power must be removed from "TDR1"

"C1" is a dpdt 24 vac control relay, used to seal-in its coil and provide interlocking means to the UV lights.

If all doors are closed, all the "SW1"s will allow "C1" to energize, as long as power is available.

By selecting "CS-1" to the "on" position, the 24vac control power circuit will be energized. As long as all doors with door switches (SW1) are closed and upon detection of power to the 1 second time-delay realy (TDR-1), the "TDR-1" normally open contracts will close for one second, energizing the contactor "C1" will remain energized. Should any one door having "SW1" mounted, were to open, "C1" will de-energize, deactivating the UV lamps. Closing all doors will not turn on UV lights. "CS-1" will be required, to be cycled "Off" then back "On" to allow the lights to come back on. If the power is removed from the UV control panell and re-energized (such as when power fluctuates off then back on), the UV lights will reactivate automatically. The "IL" "UV Light In USe" indcator lamp will allow the user to know if the lights have been energized.

LD16609

FIGURE 32 - UV CONTROL PANEL WIRING (GREATER THAN 8 AMPS) (CONT'D)

AIR MEASURING DEVICE CONNECTIONS

Air Measuring at the Fan Inlets

- COMETER is a probe attached to the fan bearing support on Comefri Forward Curve fans from size 7 x 7 up to 18 x 18. The probe is located on the outboard side of the housed fan assembly. The probe is piped to the negative (-) port of a factory mounted transducer on the fan wall. The positive (+) port is left open to the fan section. Wiring is not provided to the transducer unless factory packaged controls were selected.
- PIEZORING (PIEZOMETER) is a fitting or series of fittings in the inlet cone(s) of housed fans larger than 18 x 18 and all sizes of Plenum fans that are combined into a single connection piped to the negative (-) port of a factory mounted transducer on the fan wall. The positive (+) port is left open to the fan section. Wiring is not provided to the transducer unless factory packaged controls were selected.

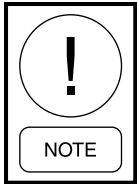

The fan manufacturer does not recommend placement of the flow measuring probes inside the fan inlet cone in the path of airflow. These devices create disturbances and unpredictable performance losses.

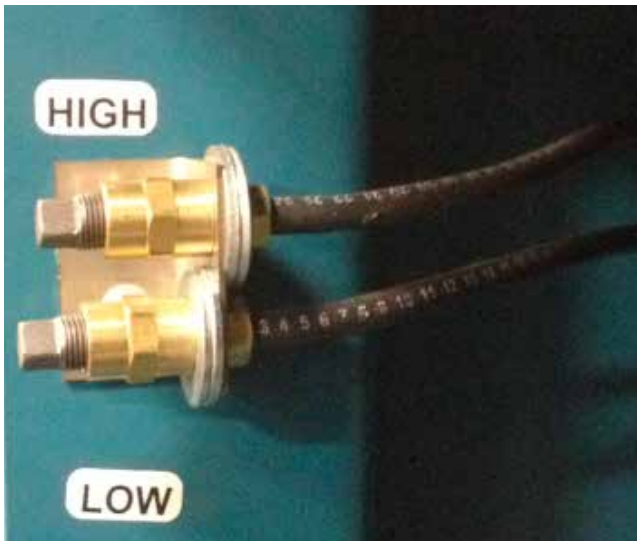

LD17231

FIGURE 33 - HIGH AND LOW CONNECTIONS FOR AN IN FAN AIR MONITORING SYSTEM



LD17232

FIGURE 34 - HIGH AND LOW CONNECTIONS AND ASSOCIATED TUBING FOR FAN MOUNTED AIR MONITORING SYSTEM

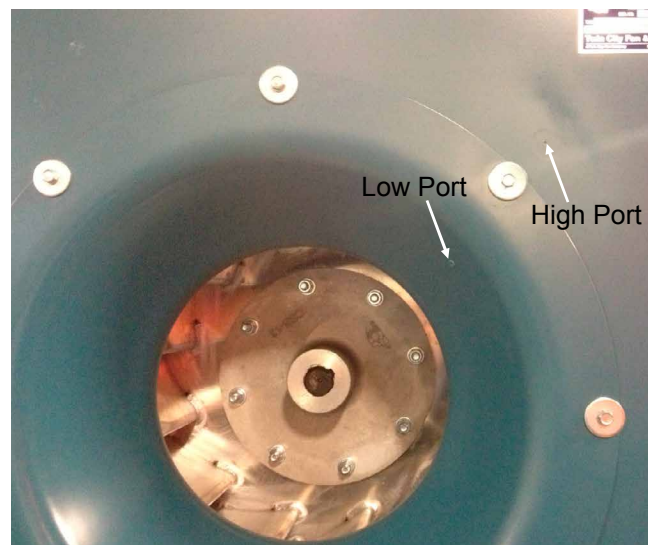

LD17233

FIGURE 35 - PORT LOCATIONS FOR FAN MOUNTED AIR MONITORING SYSTEM

Air Measuring at Unit Outside Air Inlets

- AMS-60 used on indoor air handlers usually measure outside air. This can be provided with one or two pairs of positive (+ or High) and negative (- or Low) pressure tube connections. Connect (+) & (-) respectively to the (+) & (-) ports of the transducer(s). Wiring & transducer are not provided unless factory packaged controls were selected.

- EAML used on outdoor air handlers usually to measure outside air. This can be provided with one or two pairs of positive (+ or High) and negative (- or Low) pressure tube connections. Connect (+) & (-) respectively to the (+) & (-) ports of the transducer(s). Wiring & transducer are not provided unless factory packaged controls were selected.

INSTALLING EXTERNAL VENT PIPING FOR OUTDOOR AHUS

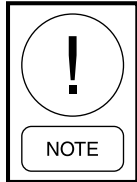

For outdoor AHUs with an overall height less than 102 in (8 1/2 ft), the external vent piping parts will be factory installed.

For outdoor AHUs with an overall height more than 102 in. (8 1/2 ft), the external vent piping parts will be shipped loose for field mounting. *Figure 36 on page 45* shows some generic instructions to install the piping parts. An installation manual specific to the fuel venting system will be provided.

Condensate Drain Arrangement

The indirect fired gas heat exchanger has the potential to create **highly acidic condensation**, particularly during extended operation at low capacity or low firing rate conditions. To insure proper drainage, use the following instructions as shown in *Figure 37 on page 46*.

When constructing the condensate trap for the heat exchanger drainage system, make sure the trap is tall enough to handle the total static pressure (TSP) of the indoor blower at low fire times. For example, if a TSP is 6 in. at low fire, construct a trap that is 12 in. tall as shown in *Table 2 on page 46*.

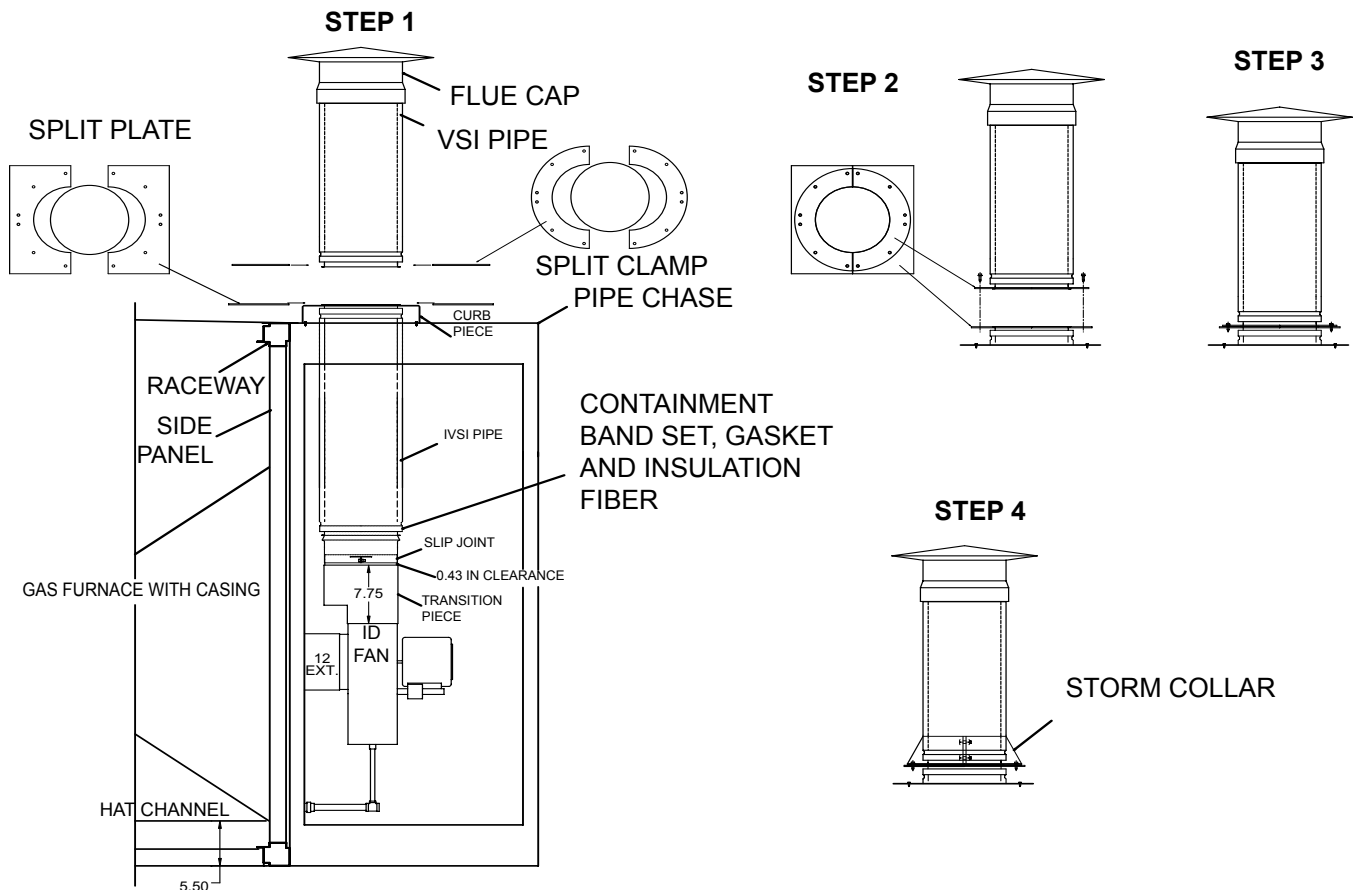

FIGURE 36 - GAS FURNACE FUEL VENTING SYSTEM

LD13326

TABLE 2 - TSP AND DRAIN TRAP

MODEL	DRAIN NPT	A	B	C
DF-15/25	1/2 in.	4 in.	2 in.	2 in.
DF-30/50	1/2 in.	8 in.	4 in.	4 in.
DF-60/75	1 in.	8 in.	4 in.	4 in.
DF-85/200	1 in.	12 in.	6 in.	6 in.
DF-225/400	1 in.	16 in.	8 in.	8 in.



Failure to follow these instructions may cause excessive condensation buildup, resulting in water damage to the facility and/or a cracked heat exchanger.

1. Observe local codes for gravity condensate drainage requirements.
2. Install the AHU at an elevation that enables proper condensate drainage and trapping dimensions as shown in *Figure 37 on page 46*. Minimum trap dimensions **MUST** be accommodated.
3. The condensate drain line size must be the full line size of the heat exchanger drain connection.

4. Drain lines, fittings, and supports should conform to local codes, and be suitable for the application.
5. Condensate drain and trap discharge should be pitched away from the equipment at a slope of 1/4 in. per linear foot or as local code dictates.
6. For outdoor or unconditioned space installations, local climate may dictate the need to heat trace and/or insulate the exposed drain lines and trap. Frozen drain lines and/or trap will cause build up of condensate inside the heat exchanger, resulting in leakage and damage to the AHU, and possibly to the building.
7. Provide unions in drain lines to allow removing the trap for periodic cleaning of drain lines and the trap. When the burner is operated at low capacity for extended periods, more condensate is generated, and with it deposits of solids in the condensate drainage system.
8. Provide the ability to prime the trap. During initial and seasonal start-up, trap inspection and priming is required. Condensate in the trap will evaporate during long periods of non-use.

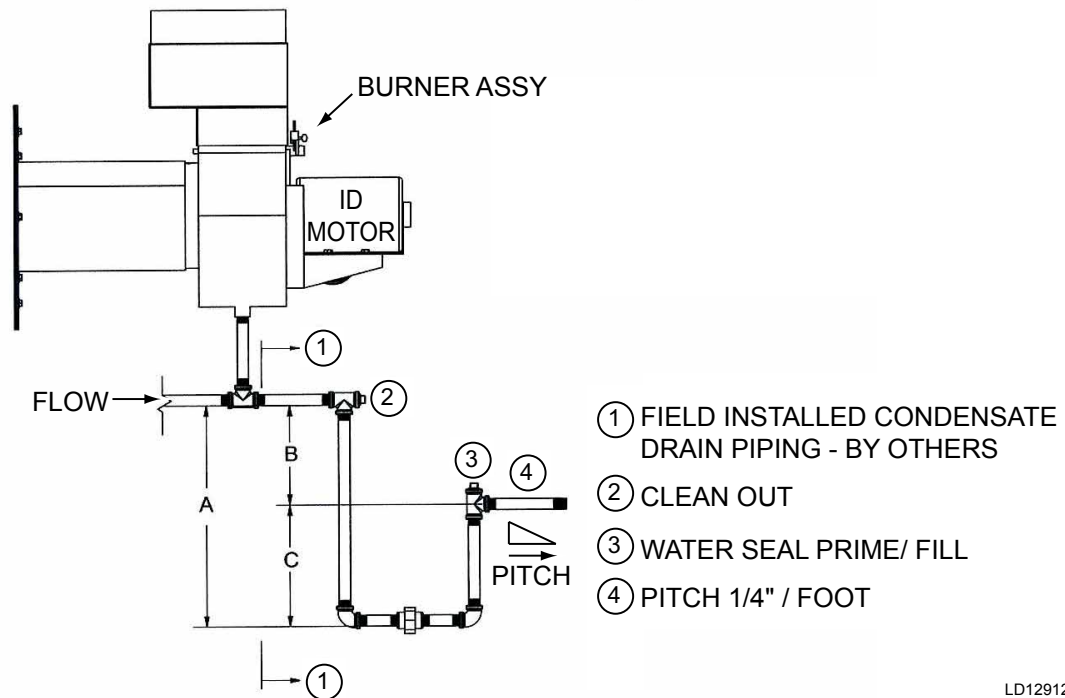

LD12912

FIGURE 37 - GAS FURNACE CONDENSATE DRAIN TRAP

FIELD PENETRATIONS FOR PIPING AND ELECTRICAL CONNECTIONS



Use only metal cutting hole saws and/or blades to make penetrations thru panels. Never use a cutting torch due to foam insulation.

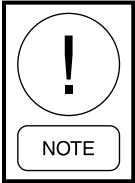

Electrical conduits must be sealed internally to prevent airflow and moisture condensation.

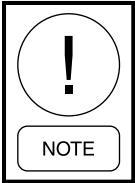

For small sizes such as 1/2" iron pipe, 1/2" conduit or 5/8" O.D. copper and smaller; it is acceptable to use caulk instead of a grommet.

Tools Required

- Drill motor.
- Pilot starter bit.
- Hole saws-approximately 2-1/2", 3-1/4" and 4-1/2" diameter for holes.
- Power cords as required.

Material Required

- Neoprene grommet, 2-1/2", 3-1/4", 4-1/2" or 5-1/2" as required.
- Cold galvanized paint.
- Touchup spray paint, champagne, P/N 044-03504-000 (for outdoor unit exterior only).
- Caulk, YORK P/N 013-03317-050 aluminum gray or 013-03317-040 for outdoor units with champagne paint.
- Exacto knife.
- Clean up supplies.

Procedure

See *Figure 38* on page 48.

1. Make sure any components; bulkheads or other obstructions are disconnected from panel inside and out.
2. Layout location and dimensions of hole opening to be cut. Do this on both sides of double wall panels.
3. Carefully cut correct hole size for the application in panel, insuring cuts on both sides line up and a smooth clean cut is made.
4. Paint raw edges of sheet metal with cold galvanized paint.
5. Select appropriate grommet for new panel hole and cut out appropriate hole diameter for penetration with an exacto knife.
6. After paint dries, Install grommet into panel hole opening.
7. Apply sealant all around new hole opening behind lip of grommet, on both sides of panel.
8. Run pipe or conduit through grommet and make appropriate connections.
9. All modified panels must provide integrity equal to original equipment specifications.
10. Reconnect any components, bulkheads or other fixtures that were disconnected from panel in step # 1.
11. Thoroughly clean up inside and outside air unit.

WATER AND STEAM COILS		
NOMINAL PIPE SIZE	ESCUTCHEON DIMENSIONS	
	O.D.	I.D.
.500	3.00	.550
.750	3.00	.815
1.000	3.00	.815
1.500	6.00	1.400
2.000	6.00	1.875
2.500	6.00	2.375
3.000	6.00	3.000
4.000	7.00	4.000

DX / REFRIGERANT COILS		
CONNECTION SIZE	ESCUTCHEON DIMENSIONS	
	O.D.	I.D.
.500	3.00	.175
.625	3.00	.550
.875	3.00	.550
1.125	3.00	.815
1.375	3.00	1.000
1.625	6.00	1.315
2.125	6.00	1.875
2.625	6.00	2.375
3.125	6.00	2.875

ESCUTCHEON			
YORK PART NUMBER	O.D.	I.D.	THICKNESS
028 14910 001	3.00	.175	.125
028 14910 002	3.00	.550	.125
028 14910 003	3.00	.815	.125
028 14910 004	3.00	1.000	.125
028 14910 005	6.00	1.315	.125
028 14910 006	6.00	blank	.125
028 14910 007	6.00	1.400	.125
028 14910 008	6.00	1.875	.125
028 14910 009	6.00	2.375	.125
028 14910 010	6.00	2.875	.125
028 14910 011	6.00	3.000	.125
028 14910 012	7.00	4.000	.125

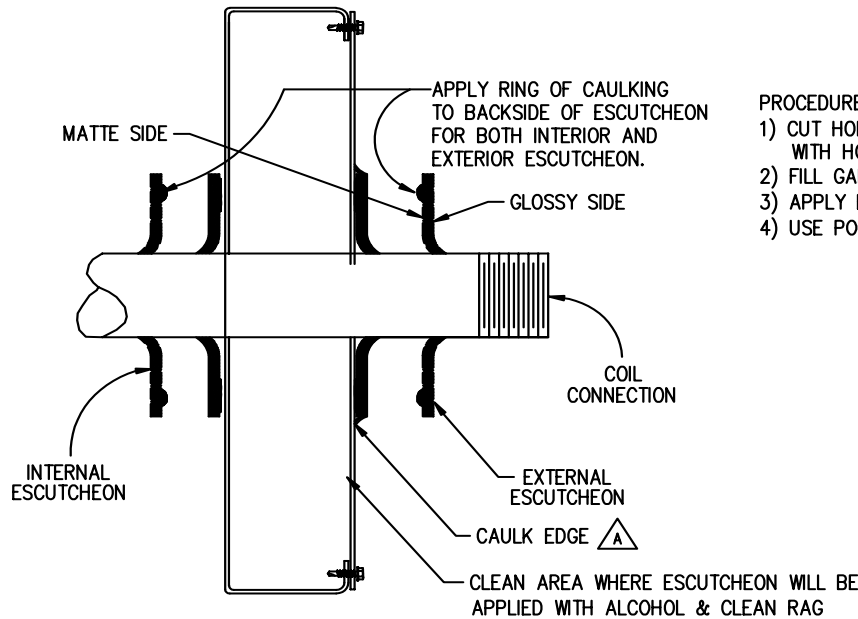

- PROCEDURE:**
- 1) CUT HOLE $\frac{1}{2}$ " LARGER THAN PIPE O.D. WITH HOLE SAW
 - 2) FILL GAP WITH FOAM
 - 3) APPLY ESCUTCHEON AS SHOWN
 - 4) USE POLYURETHANE CAULK.

PART	PART NUMBER
Caulking Gray	013-03317-050
Champagne	013-03317-040
Champagne Touch-up Spray Paint	044-03504-000

For these and all other parts contact York Product Service at 814-479-4005



Use only metal cutting hole saws and/or blades to make penetrations thru panels. Never use a cutting torch due to foam insulation.

FIGURE 38 - GAS FURNACE DRAIN TRAP

GENERAL ELECTRICAL INFORMATION

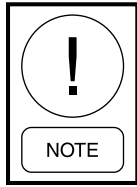

All field wiring must conform to the International Building Codes (IBC), National Electrical Code (NEC) and local codes.

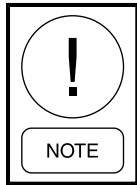

The AHU is ETL listed. Some components are UL labeled. Any changes in the field may affect its validity.

The current characteristics of phase, cycle and voltage are stamped on the nameplate of each component. Use the following instructions to set up the electrical connections.

- Install electrical conduit connections, which are made to exposed boxes, to the bottom of the box. Outdoor installation must be made watertight. The installing contractor is responsible for electrical conduit penetrations through the building roof.
- Seal the penetrations through the panels.
- Externally and internally seal the electrical conduits that penetrate the AHU exterior (walls, pipe chase or floors) so that the unconditioned air will not be drawn into the AHU through and around the conduit. Unconditioned air will result in condensation that will fail components prematurely.
- Check all accessible electrical connections, which contain several strands of wire, for tightness prior to start-up. The wires are tightened at the time of assembly, but check, and retighten them, if necessary. The dangers of a poor connection are overheating and component failure.

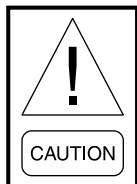

DO NOT PENETRATE any main or auxiliary drain pan or roof of outdoor AHU.



DO NOT PENETRATE wireways in any manner. The sheet metal channels, which run along the top panel, contain electrical wires and connections. Electrical shock and/or damage to the AHU may result.

Electrical drawings are provided in the information packet on the inside of the AHU access door. Major optional components will have specific electrical and installation information inside the control panels or will be attached. Refer to *SECTION 4 - WIRING DIAGRAMS* in the *Air Handling Units - Operation and Maintenance Manual (Form 102.20-OM2)*. for more information on the electrical drawings.

POWER CONNECTIONS

Single Point Power

When ordered, the single point power connection provides the installer with a main disconnect switch as shown in *Figure 39 on page 49*. The line side of this switch (top) is where the installer is to connect his main power wires. The devices included in the single point power option are :

- Supply, Return, and Exhaust Fans
- Energy Recovery Wheel
- Gas and Electric Heat
- Ultra-violet Lights



LD16607

FIGURE 39 - SINGLE POINT POWER CONNECTION

Special quoted devices not included in this option may be purchased with the AHU, and will require separate, additional power wiring by the installer. When this option is NOT purchased, the installer is responsible for wiring to each electrical component.

Motors for Supply, Return, and Exhaust Fans

A motor connection diagram may be found on the inside of the motor terminal box or on a tag attached to the motor. Be sure to make a flexible conduit connection at the motor to permit fan belt adjustment and movement of the spring isolated fan assembly. Refer to the motor data nameplate for all motor specifications as shown in *Figure 40 on page 50*.



Baldor

FIGURE 40 - TYPICAL MOTOR DATA/NAME PLATE

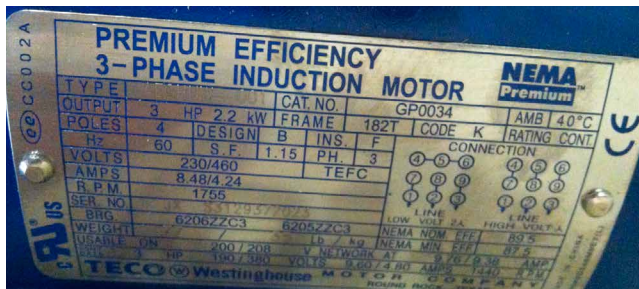

Teco

FIGURE 41 - ANOTHER TYPICAL MOTOR DATA/NAME PLATE

To access the motor electrical box when the motor is installed in the configuration as shown in *Figure 42 on page 50*, use the following instructions.'

1. Remove the motor bolts that secure the motor to the motor base.

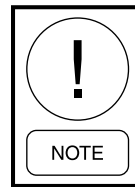

In some applications, only three bolts need to be removed. The fourth bolt, located on the opposite side of the electrical box, does not have to be removed but will need to be loosened. After it is loose, rotate the motor to access the electrical box to make the connections.

2. Remove the belts.
3. Rotate the motor or move it back far enough to access the electrical box.
4. Connect the motor wiring per the motor wiring diagram.
5. Replace the motor electrical box cover.
6. Rotate or move the motor back into place and secure it to the base with the bolts.
7. Reinstall the belts to the proper alignment and tension according to the drive kit label found on the fan assembly.

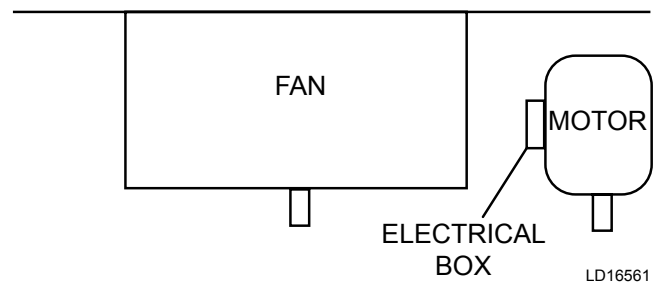

FIGURE 42 - ACCESS ELECTRICAL BOX

WIRING THE ENERGY RECOVERY WHEEL

It is the installer's responsibility to wire the energy recovery wheel, if single point power was not purchased. Using the attached plug and/or pigtail is optional. Johnson Controls does not provide pre-wired mating cables.

For wheels that are 52-in. diameter and smaller, the motor comes with a cord. Wheels that are 54 in. in diameter and greater, the motor does not come with a cord. Single phase motors have a 3-pin standard AMP connector on the cord. Three phase and VFD models have a 4-pin standard AMP connector on the cord.



LD12591

FIGURE 43 - TYPICAL POWER WIRING OF ENERGY RECOVERY WHEEL

WIRING THE GAS HEAT DEVICE

It is the installer's responsibility to wire this device, if the single point power connection was not purchased.

Panel locations and sizes vary based upon the AHU's size and burner configurations. Burner voltage is selected to match the primary AHU voltage. Modulation control voltage 2-10 VDC is standard.

Electrical penetrations can come through the floor or side wall panels. Drill and properly seal any penetrations to keep out moisture. Refer to the service manual for more information.

Make power connections per the wiring diagrams provided on the inside of the burner control panel. Refer to the *Air Handling Units - Operation and Maintenance Manual (Form 102.20-OM2)* for more information.



LD11597

FIGURE 45 - MAIN POWER AND CONTROL PANEL WITH COVER OPEN

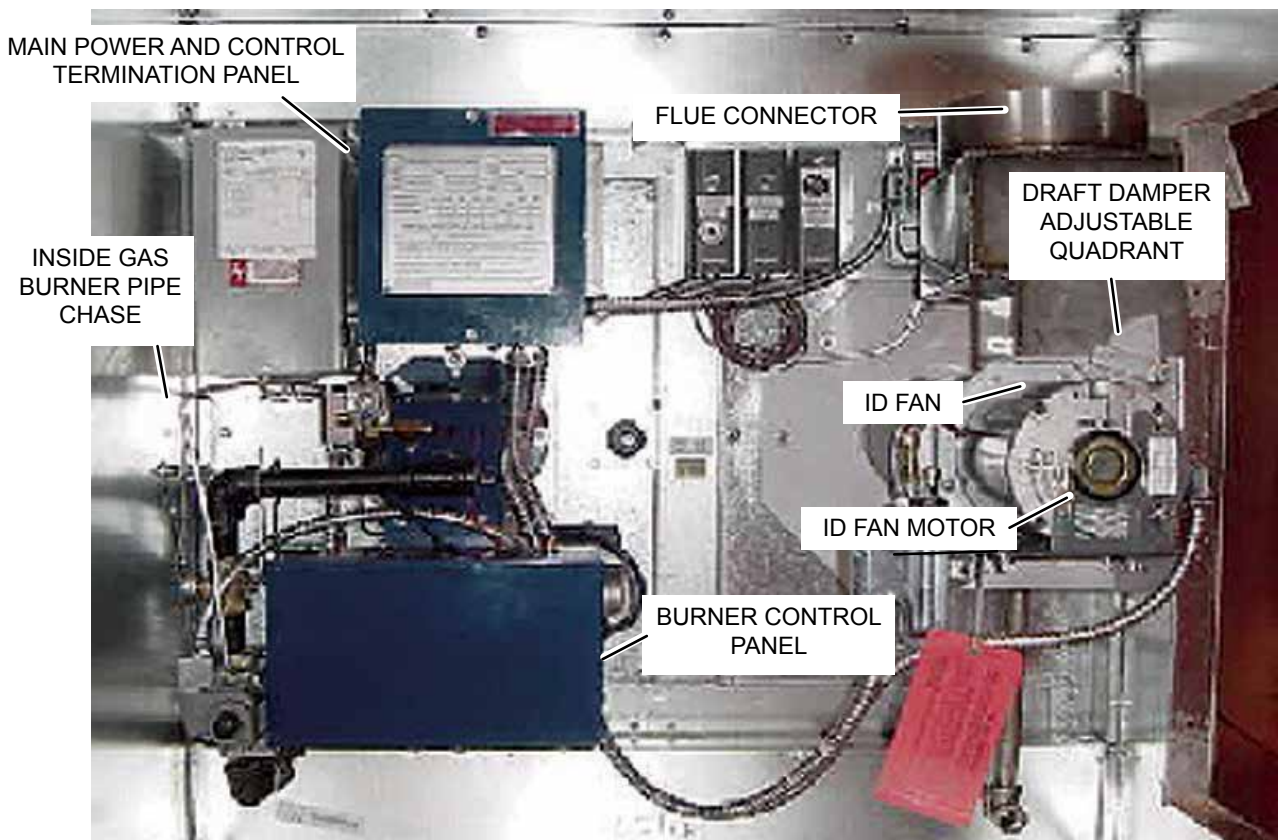

LD11596b

FIGURE 44 - GAS BURNER COMPONENT LOCATIONS

WIRING THE ELECTRIC HEAT DEVICE

It's the installer's responsibility to wire this device, if the single point power was not purchased.

Power Options

The available power options are listed below:

- 460V-3PH
- 208/230V-3PH
- 380V-3PH
- 575V-3PH

Disconnect Switch Options

The available disconnect switch options are fused and non-fused.

Knockouts are provided on the top and bottom of the enclosure for field penetrations. Drill the foam panel to utilize these knockout locations. Seal the penetrations to prevent airflow or leakage. Refer to the service manual for more information.

Use the following instructions to connect the disconnect switch:

1. Hook up the power, as shown in *Figure 47* on page 52. Terminals (shown) are for a 2-stage 24 VAC control interface, and may require a 120VAC control interface, based upon the options selected. Refer to the wiring diagram on the inside cover of the electric heat control panel for more information.

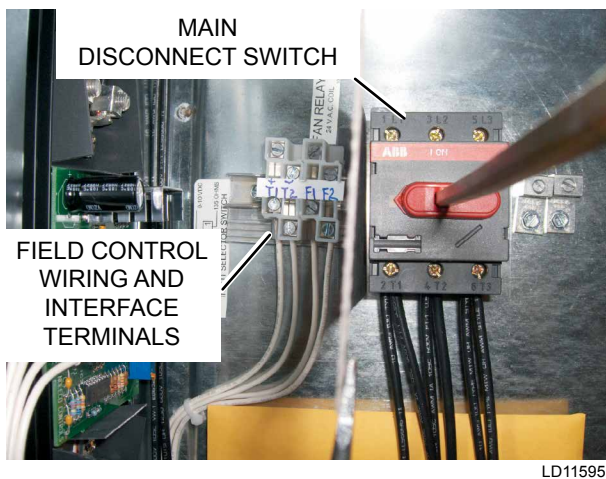

FIGURE 46 - TYPICAL FIELD AND POWER CONNECTIONS

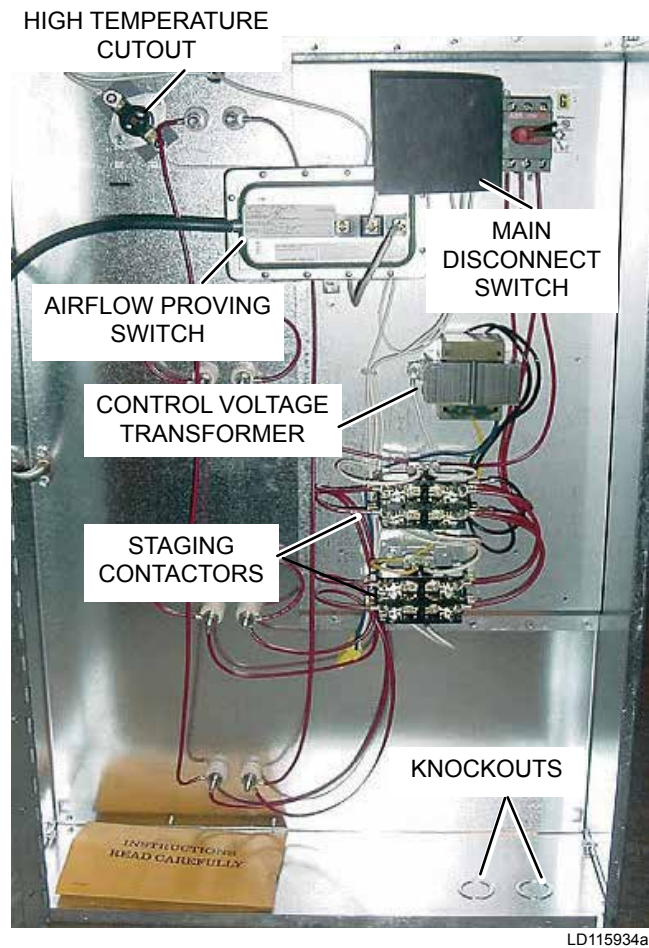

FIGURE 47 - TYPICAL ELECTRICAL HEAT CONTROL PANEL INTERIOR WIRING AND COMPONENTS

2. Seal the electrical conduits that penetrate the AHU's exterior (walls, pipe chase or floors) externally and internally so that the unconditioned air will not be drawn into the AHU through and around the conduit. The unconditioned air will result in condensation that will fail components prematurely.
3. Check all accessible electrical connections for tightness prior to the actual startup. Many connections contain several strands of wire, and while they were tightened at the time of assembly, they should be checked and retightened if needed. The dangers from a poor connection are overheating and component failure.



DO NOT PENETRATE any main or auxiliary drain pan.

Control Options

The available control options are:

- **Staging** - Has no controller, but contactors are energized by providing control power to each contactor from the external BMS source.
- **Step Controller** - A mechanical/electrical device that receives a 0 to 10 VDC or 4 to 20 mA signal, and step-on heat stages.
- **Vernier Silicone Controlled Rectifier (SCR)**
 - Completely electronically controlled by varying signal and varying output between stages.
 - Increases power to a stage by modulation until another stage is needed.
 - Energizes another stage and modulates power until another stage is needed. 0 to 10 VDC or 4 to 20 mA.
 - Less expensive than a full SCR. This system utilizes a step controller and one SCR that modulates and resets for each stage.
- **Full SCR** - Completely electronically controlled by varying signal and varying output of a controller like a VFD for electric heat with 0 to 10 VDC or 4 to 20 mA. The controller modulates a separate SCR for each stage.

Installing Electrical Heat Option



Rotating parts and electrical shock hazards exist. Lockout and tagout the fan motor(s) and heat power disconnects before servicing, using the latest procedure. Failure to follow proper safety precautions may result in serious injury or death.

Application Information

Follow the procedure given in these instructions to find the minimum air velocity for safe operation. The minimum velocity must be provided at all points over the heater face area.



Failure to meet this requirement may result in serious damage or nuisance thermal cutout tripping.

The maximum air inlet temperature for open coil heaters is 100°F, and for finned tubular heaters is 80°F.

Sufficient working space must be provided per paragraph 110-26 of the NEC.

This electric heater is not designed for or intended to be used for temporary heat prior to system startup/balancing.

Mechanical Installation

All heaters will contain an adjustable airflow switch in the heater control panel. This switch will be preset to close at a differential pressure of approximately 0.3 in. water column (WC). In all cases, the switch will be connected to a pressure probe positioned in the airstream as shown in *Figure 48 on page 54*. This probe has an arrow stamped on it that is viewable from inside of the control panel. When the heater is located upstream of the fan, this arrow will point away from the fan. When the heater is located on the downstream side of the fan, the arrow will point away from the fan or with the airflow.

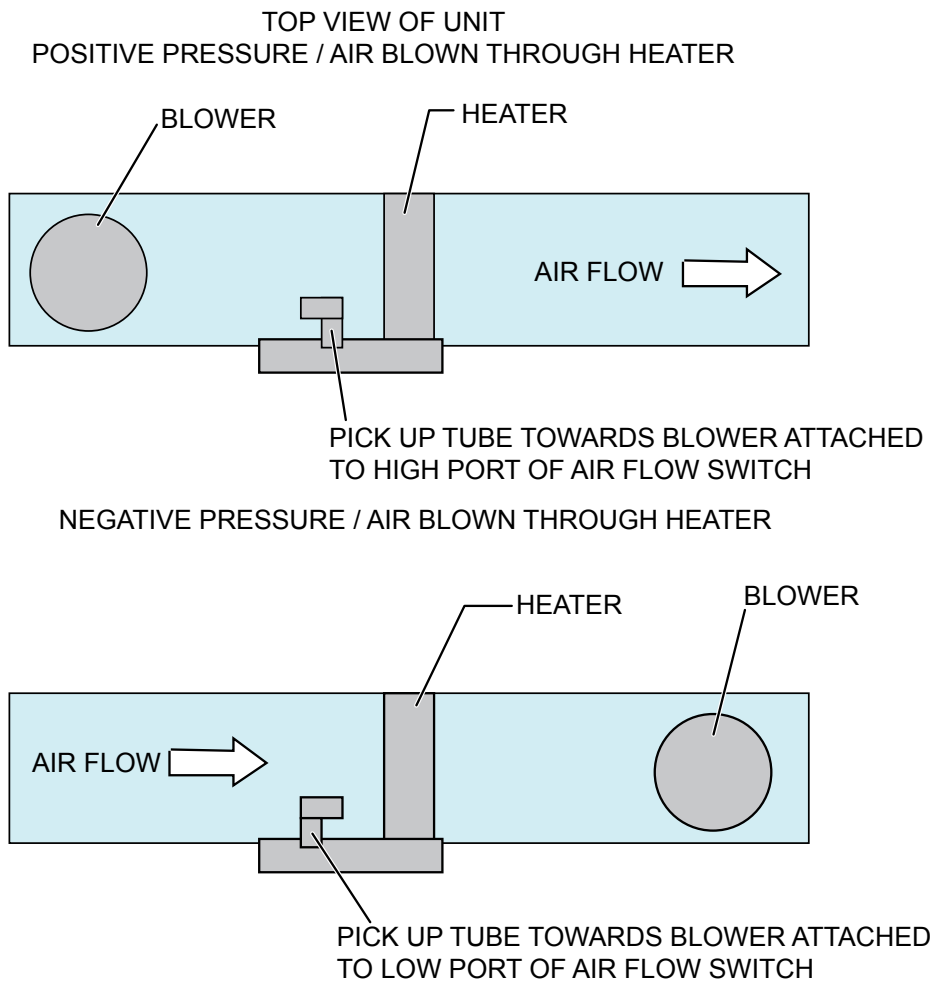

LD12468

FIGURE 48 - PRESSURE PROBE DIRECTION

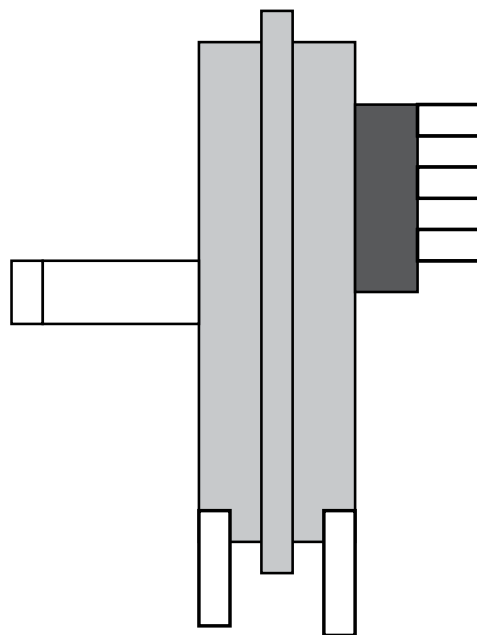

LD12470

FIGURE 49 - AIR FLOW SWITCH CONNECTIONS

If it is incorrectly installed, remove the two screws holding the pressure probe in place and rotate 180° and reinstall. The airflow switch pressure port that is not connected to this pressure probe will be run to the exterior of the AHU to source a reference differential pressure.

In some situations it may be necessary to adjust this airflow switch setting to allow for proper operation as shown in *Figure 49 on page 54*. Take precautions to make sure that the airflow switch does not indicate false airflow.

Visually inspect the heater elements, prior to using the heater. If physical damage is evident, use a megohm test to validate the heater elements are safe use. If a minimum value of 10 megohms is not achieved, then any damaged elements or ceramic insulators must be replaced, prior to operation.

Electrical Installation

1. Follow the wiring diagram on the inside of the terminal box.
2. Make supply connections with copper wiring rated for 75°C minimum.
3. If supply connections are for 250 volts or greater, all wiring must be insulated for 600 volts.
4. When making line connections to heater element terminals for finned tubular heaters only, apply a 1/4 in. wrench to the flat section of the terminal immediately below threads. Otherwise, damage to the terminal may result.
5. Size supply conductors for heaters rated less than 50 kW at 125% of rated load. On heaters rated 50 kW and greater, size the supply conductors at 100% of rated load, if indicated on the wiring diagram. The line current for a single or three phase load is calculated as follows:

$$\begin{aligned} \text{Single Phase Line Current} &= \frac{\text{kW} \times 1000}{\text{Voltage}} \\ \text{Three Phase Line Current} &= \frac{\text{kW} \times 1000}{\text{Voltage} \times 1.73} \end{aligned}$$

6. *Table 3 on page 55* shows the maximum current for 75°C copper wire with no more than three conductors in a raceway, which is based on the NEC - Table 310-16. The amperages are 125% and 100% wire sizes. If there are more than three conductors in a raceway, de-rate these amperages per *Table 3 on page 55*.

When connecting heaters with more than one stage, wire stage No. 1 so that it is the first stage on, and the last stage off.

7. Wire the heater so that it cannot operate unless air is flowing over it, which can be accomplished by using a built-in airflow switch and a remote interlock. See the wiring diagram located inside of the electric heater control panel for the method used with the heater and provide appropriate interlock wiring as illustrated.
8. If not supplied as part of the heater, install a line disconnect switch or main circuit breaker in accordance with the NEC. Depending upon the heater's location and accessibility, a built-in disconnect switch may meet this requirement.
9. Check all electrical connections in the heater, including both field and factory made connections, for tightness before operating the heater. After a short period of operation, check all connections again for tightness.

TABLE 3 - MAXIMUM CURRENT

AMPS		WIRE SIZE AWG/MCM	AMPS		WIRE SIZE AWG/MCM	AMPS		WIRE SIZE AWG/MCM
125%	100%		125%	100%		125%	100%	
12		14	80	100	3	184	230	4/0
16		12	92	115	2	204	255	250
24		10	104	130	1	228	285	300
40		8	120	150	0	248	310	350
52	65	6	140	175	2/0	268	335	400
68	85	4	160	200	3/0	304	380	500

10. If the heater is wired to a heating/cooling thermostat, use a thermostat with isolating circuits to prevent possible interconnection of Class 2 outputs.
11. If the heating elements are divided into several sections with resistance wire between two or more sections, calculate the maximum kW per sq. ft as follows:

$$\frac{\text{Heater nameplate KW}}{\text{Number of heated sections} \times \text{area of one heated section}}$$

ELECTRIC HUMIDIFIER

It's the installer's responsibility to wire this device because this device is not included in the single point power option.

Figure 50 on page 56 represents a typical electric humidifier panel layout. The supply power knockout is located in the bottom of the electrical panel as shown in Figure 51 on page 56. All conduits beginning or ending on the inside of the pressurized or conditioned areas (i.e. AHU) must have the conduit openings sealed to prevent air from passing through it.

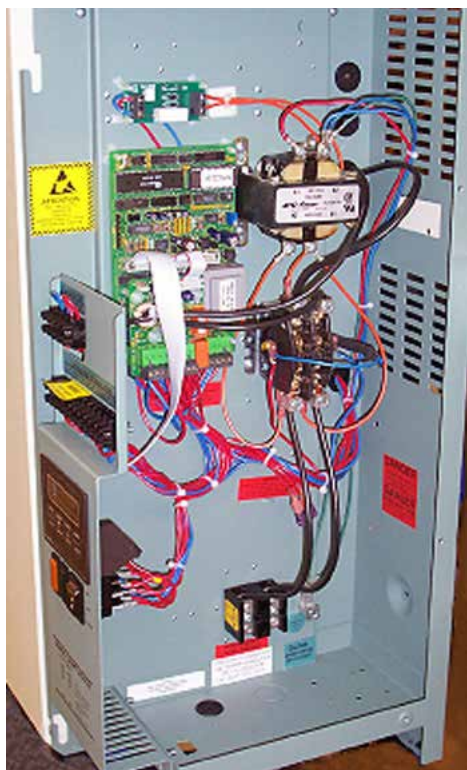

LD11726

FIGURE 50 - LAYOUT OF TYPICAL HUMIDIFIER PANEL



LD11727

FIGURE 51 - SUPPLY POWER KNOCKOUTS

All AHU penetrations must be sealed to prevent air and water leakage. Refer to the *Penetrations and Grommet Details* section in the service manual.

Field provided disconnects must provide circuit protection according to the humidifier nameplate. All field wiring to the humidifier must be in accordance with NEC and local codes.

HUMIDIFIER

Control wiring diagrams are located in the humidifier manufacturer's operator's manual, which can be found inside the control panel or it is attached. Factory package control drawings may not include humidifier points as shown in Figure 52 on page 56.



LD11725

FIGURE 52 - HUMIDIFIER POINTS

If the humidifier operator's manual cannot be located inside the humidifier, call Johnson Controls Airside Product Technical Support to get a copy of the electronic version.

COIL PIPING

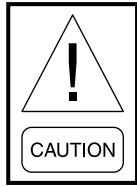

Do not test, clean and flush piping through this equipment.
Isolate this equipment from pressure testing of water, steam gas and air piping.

1. Consult the job specifications and submittal drawings for specific piping requirements, coil connection sizes and location. The AHU should be level to assure proper venting and draining of coils. The piping arrangements must provide for a balanced flow in multiple coil installations as shown in *Figure 53 on page 57*.

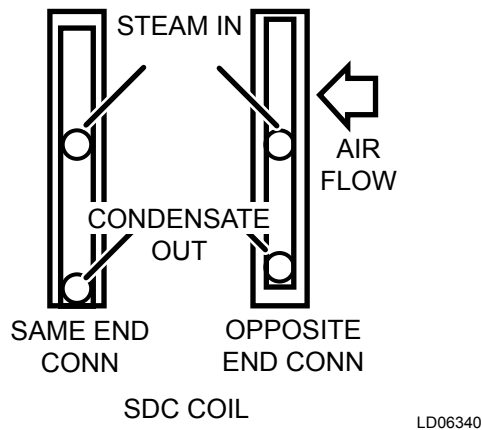

FIGURE 53 - FACTORY COIL CONNECTIONS

2. Support all connecting piping independently of the coils. Provide swing joints or flexible fittings in all piping connections, particularly adjacent to heating coils to absorb expansion and contraction strains because rigid piping connections can cause coil damage.
3. The coil supply and the return pipe connections are labeled. When attaching the piping to the coil header, make the connection only tight enough to prevent leaks. Excessive tightening may cause damage to the header.

Hold a backup wrench firmly on the coil connection so that when tightening the connecting piping, the torque is not transmitted to the coil header, which could damage the coil connection.

Application Notes - All connections are male piping threaded except DX coils, which are soldered. Drain and vent taps on water coils are pipe thread, and shipped with plugs installed. These taps are installed approximately two in. back from the end of the threaded connections. Install the pipe for balanced flow and to assure even airflow.

Staggered Coils

Staggered coils in the AHUs equipped with an optional expanded cabinet will have connections brought to the AHU exterior for liquid or steam coils as shown in *Figure 54 on page 57*. DX coils are not included.

The external connections are a threaded pipe or grooved pipe for the contractor to make his connections when the media is liquid, or a threaded pipe when the media is steam.

It's the installing contractor's responsibility to insulate the piping extensions inside the AHU.

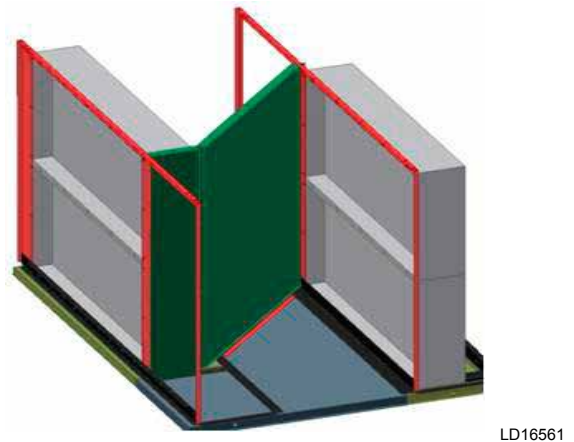

FIGURE 54 - STAGGERED COIL - ANGLED WALL

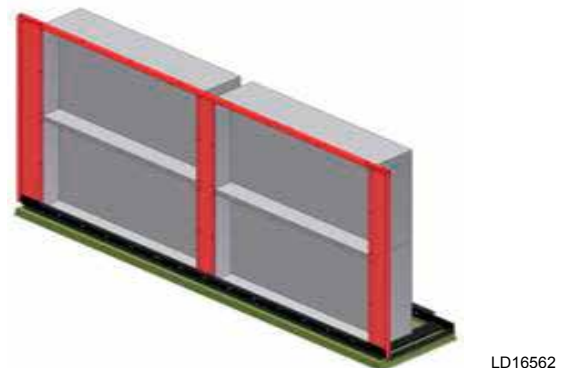
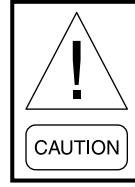

FIGURE 55 - SPLIT COIL - OPPOSITE SIDE CONNECTIONS

Hot and Chilled Water Coils

1. Connect the water supply to the header connection on the leaving air side of the coil to achieve the counter flow of water and air. The return pipe will be connected to the remaining coil connection.
2. Install an air vent in place of the top pipe plug on the return header. To provide for drainage, install a drain line and shutoff valve in the supply near the coil, or in place of the plug in the supply connection as shown in *Figure 56 on page 58* and *Figure 57 on page 59*.

Water Coil Performance



Full steam pressure of water flow must be supplied at all times - modulating valves must not be used. A modulating steam valve or preheat coil can actually cause the coil to retain condensate due to a reduced pressure in the coil thus exposing condensate in the tubes to freezing conditions. With modulating steam below 5 psig (valve closure) the steam may not be fully distributed in all of the tubes in the coil, causing the outer tube to cool abnormally. This will create thermal stress that can lead to possible "outer tube failure".

The temperature rise of the air (hot water coil) or temperature fall of the air (chilled water coil) leaving the coil is dependent on the:

- Airflow across the coil,
- Gallons of water flow through the coil, and
- Entering water temperature into the coil.

Consult the job submittal form for more information.

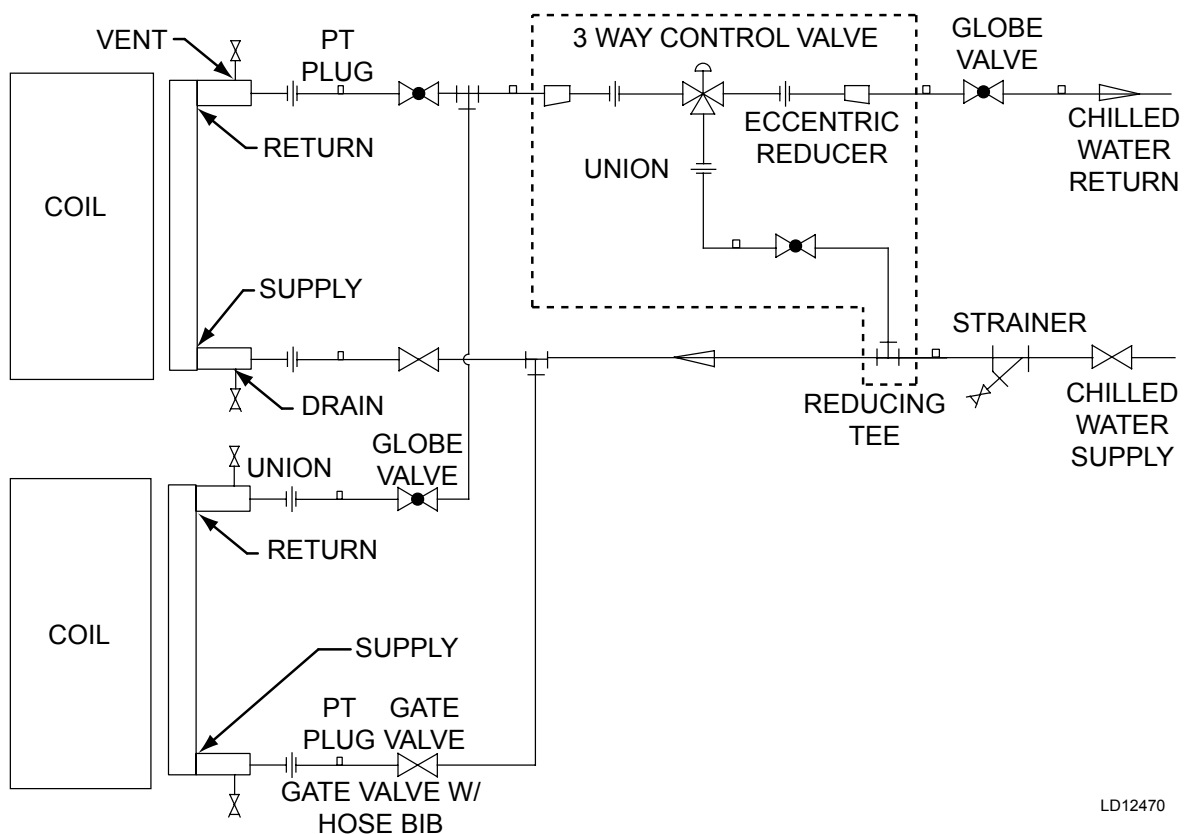

LD12470

FIGURE 56 - CHILLED WATER COIL CONNECTIONS EXAMPLE - (NOT FOR CONSTRUCTION)

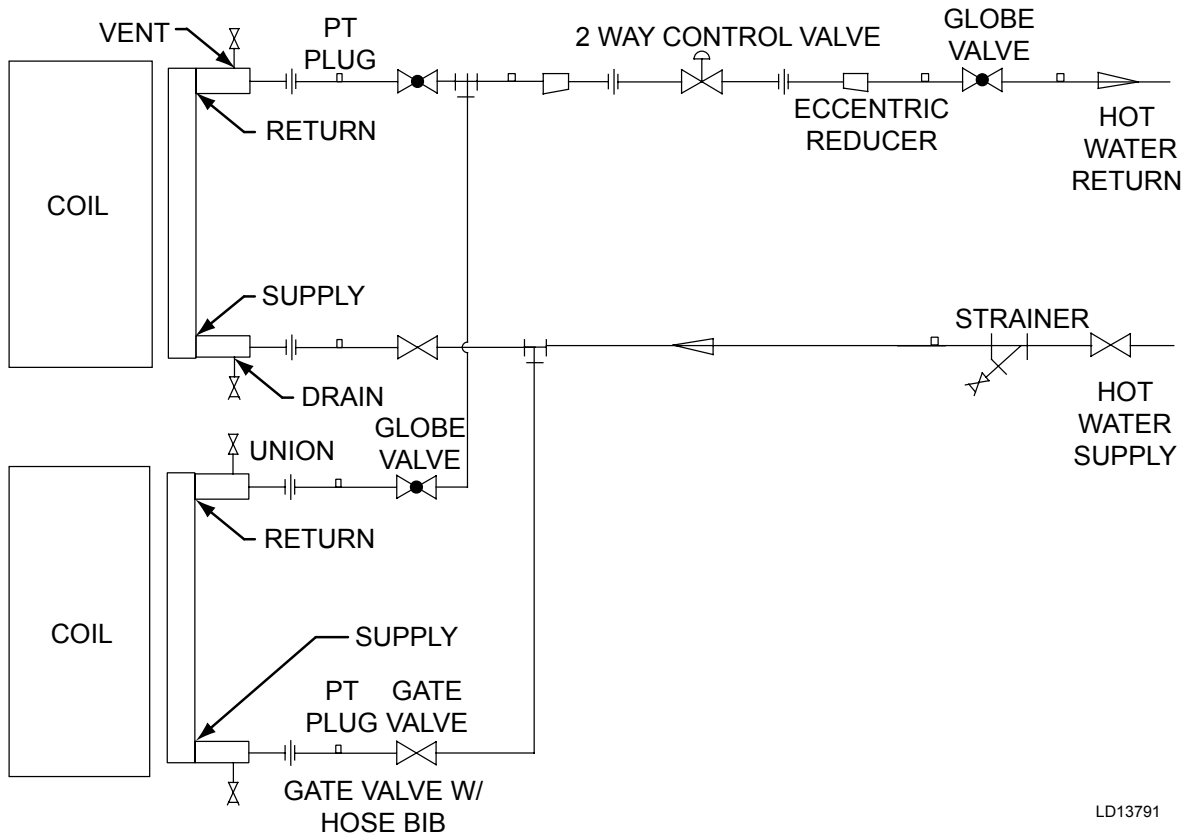

FIGURE 57 - HOT WATER PIPING WITH TWO-WAY VALVE EXAMPLE (NOT FOR CONSTRUCTION)

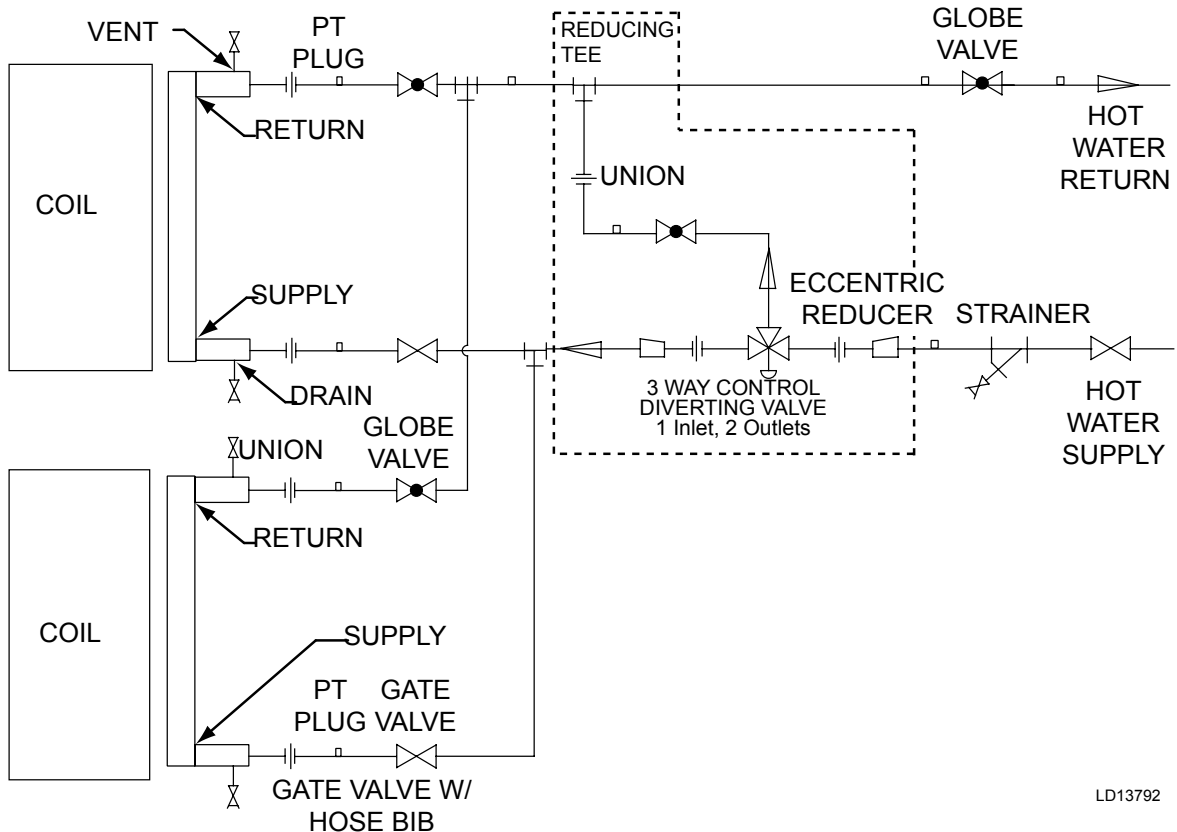

FIGURE 58 - HOT WATER PIPING WITH DIVERTING VALVE EXAMPLE (NOT FOR CONSTRUCTION)

WATER TREATMENT

Any copper tube coils may be attacked by acid condensate. Treat the coils with boiling water and CO₂ to remove the condensate, and to assure longer tube life.

Freeze Protection

Chilled water, hot water, and steam coils can be damaged during freezing weather. Take the following precautionary measures to prevent freezing:

- Positive coil freeze protection must be used in installations where any part of the water coil is subjected to temperatures of 32°F or lower, which may be accomplished by using a suitable anti-freeze solution. If the coil is not in use, it is recommended to drain the coil completely, and blow dry the inside of the tubes with compressed air.
- After draining, flush the coils with an anti-freeze solution such as 50% glycol and 50% water, which will protect from the coil from freezing to approximately -35°F at sea level. Refer to ASHRAE and ARI guidelines for more information.
- During winter when shutdowns such as power failure, night and weekend shutdowns may occur, install the controls so the return air dampers go to the fully open position, and all fresh air dampers go to the fully closed position. A source of auxiliary heat must be maintained inside the AHU cabinet.
- Other protection can include electromechanical switches and constantly flowing water; however, Johnson Controls will not be responsible for any coils damaged by freezing.

Steam Coils

The operation of steam coils is dependent on airflow quantity and temperature as shown in *Figure 59 on page 61*. Consult the job submittal form for the information specific to this AHU.

Steam Distributing Coils

Use the following instructions to clean the steam distributing coils:

- Do not bush or reduce the coil return pipe size.
- Use a full size return pipe to the bottom of a dirt pocket. The supply pipe may be reduced at the coil connection, if necessary.

- Install the coil casing level with the return down. A coil must be sufficiently elevated to allow a 12 in. minimum drop between the return connection on the coil and the trap. More than a two inch drop is required to protect the coil from freezing. The return main should be located below the trap.

Steam Control

Continuous steam supply ensures long coil life and minimizes potential trapping, venting and freezing problems. A rapid cycling of the modulating steam supply or a frequent on-off steam supply control results in repeated thermal and piping stresses which will shorten the coil life. Modulating steam control valves must not be oversized, and must be carefully selected. A substantial variation in the supply pressure will require installing a pressure-reducing valve ahead of the automatic control valve.

Light load operation with a modulated steam supply can be improved by the installation of a vacuum breaker check valve. An open relief line to the atmosphere from the return line near the coil is desirable, except on vacuum systems.

With a modulated steam supply, it is not practical to lift the condensate to an overhead return. Locate the coil well above the return, or provide condensate unit, or a boiler return trap below the coil.

Individual control valves are required on each coil installed in series with respect to airflow. When a modulating steam valve supplies two or more coils in parallel, with respect to airflow, the piping must be designed to provide uniform steam distribution to each coil.

Steam Traps

Use the following information to select the correct steam trap.

- Float and Thermostatic (F and T) traps are recommended for all low or medium pressure applications.
- Use thermostatic traps only for air venting, for outdoor applications where a F and T trap might be subject to freezing.
- Use bucket traps only for a non-modulated steam supply.
- Size the steam traps in accordance with the manufacturer's recommendations (usually several times the steady state steam flow).

- Use the actual operating conditions (coil pressure vs. return pressure) to select a trap.
- It is preferable to provide an individual trap for each coil, but a single trap may be used for coils operating in parallel with respect to the airflow. Coils in series with respect to airflow must be supplied with individual traps.
- Locate the trap at least 12 in. below the coil return connection, and lower it when freeze protection is required. Do not attempt to lift condensate modulated steam supply.

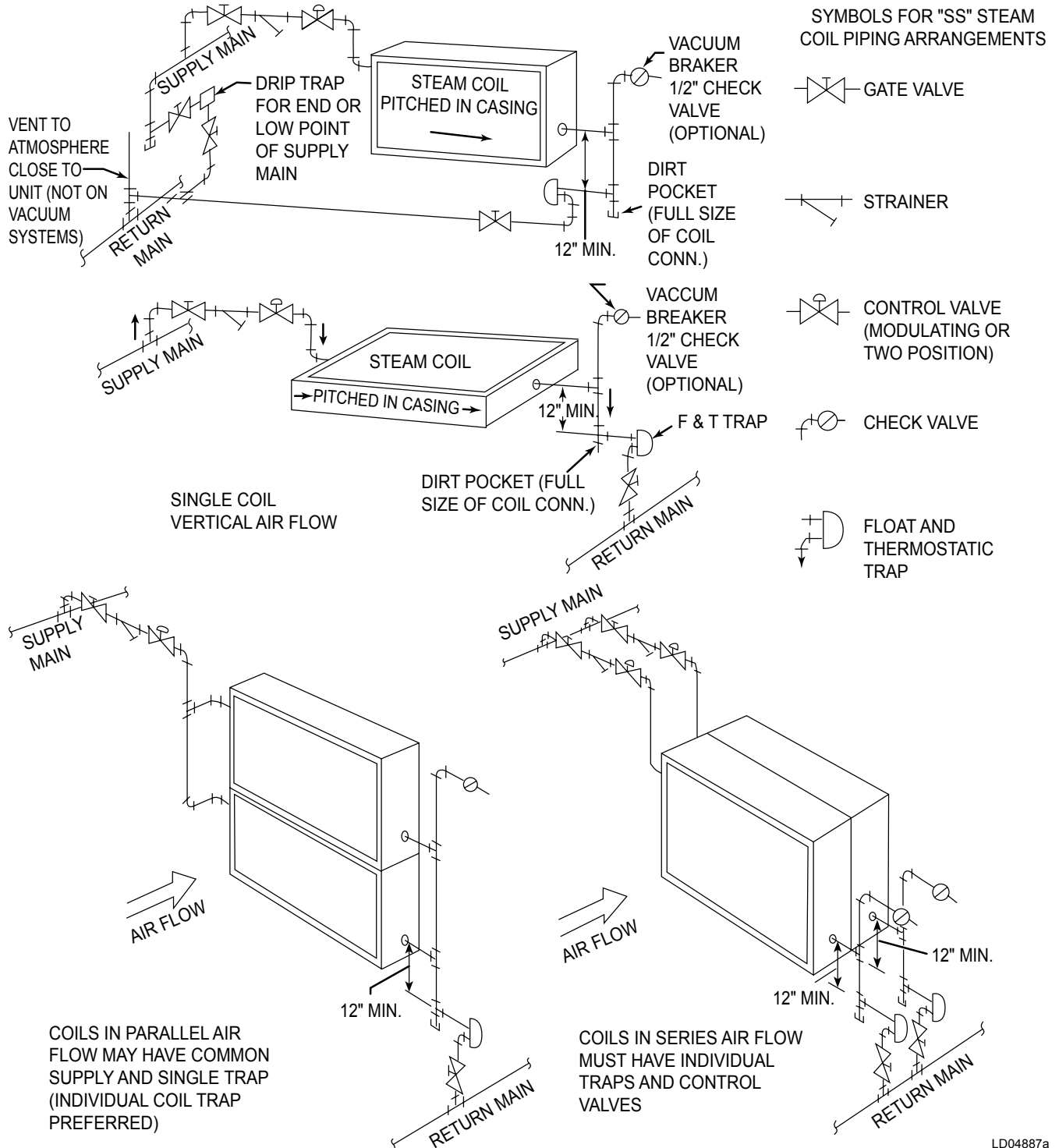

LD04887a

FIGURE 59 - STEAM COIL PIPING ARRANGEMENTS

VERTICAL TUBE INTEGRAL FACE AND BYPASS (VIFB) AND INTEGRAL FACE AND BYPASS (IFB)

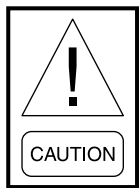

The VIFB warranty will be voided if the return piping on the lower header (inlet and return on two-row header) does not include flexible connector(s), and if the lower header(s) bolts are not removed prior to use.

The VIFB lower header must be free to float as shown in *Figure 60 on page 63*. After the coil is piped, remove the yellow bolts to allow the header to float. Always back up the coil connections when installing the fittings.

Below 35°F, the VIFB, as shown in *Figure 60 on page 63*, or the IFB, as shown in *Figure 61 on page 64*, operates with full steam pressure or full water flow at all times, which prevents freeze-up and temperature stratification.

Shipping Bolts (VIFB Only)

Return steam condensate headers or hot water supply and return headers are securely bolted to lower mounting brackets to prevent damage to the header and tubes during shipment and piping of the coils. Remove the bolts before applying steam or hot water, but after making all of the piping connections, as shown in *Figure 61 on page 64*.

Piping Suggestions

Read the following information before installing the piping.

- Support the steam and hot water field piping separately after the flexible connector to isolate the piping strains and additional expansion from the coils.
- Insulate the internal steam manifolds and piping.
- Size the steam traps three times the calculated condensate loading at the coil design conditions, based on the pressure differential across the trap, not the boiler pressure. Traps should be of types that pass condensate and air at saturated steam temperature. Inverted bucket traps should incorporate thermostatic air vents.
- Make the return connection full size as required, and reduce only at the trap. Do not use the reducing bushing on the coil return connection.

Flexible Connectors (VIFB Only)

Return steam condensate headers, hot water supply, and return headers must be free to float. A flexible connector MUST be installed as close as possible to the coil, and parallel to the headers to accommodate a minimum of 1/2 in. expansion movement of the headers.



Failure to install flexible connectors will restrict expansion of the headers, which can result in bowing of the tubes, bending of the fins, interfering with damper operation, or eventually breaking the tubes.

Refer to the service manual for more information.

Freezing Conditions

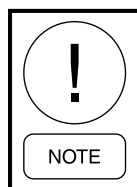

Anti-stratification baffles are standard on all IFB and VIFB coils mounted in the AHUs.

The outside air and return air must be thoroughly mixed before passing over the coil. When freezing air enters only part of the coil, it creates a greater hazard than when the airflow entering the coil is a uniform temperature.

Coils used in series with respect to the airflow must have individual controls with ample space between the coils for sensing devices, when required. Coils with two or more rows are more sensitive to freezing than single row coils.

On outdoor AHUs, locate the low limit at least 24 in. downstream of the leaving edge of the VIFB/IFB casing. The low limit element must cross the face and bypass areas and be parallel to the headers.

Refer to the IFB/VIFB operator's manual (provided) for additional piping details. The Johnson Controls factory does NOT pipe the connections to the AHU exterior.



LD09630

FIGURE 60 - IFB COIL (HORIZONTAL TUBES AVAILABLE WITH STEAM AND HOT WATER)



LD09631

FIGURE 61 - VIFB COIL (FACE-MOUNTED ACTUATOR SHOWN)

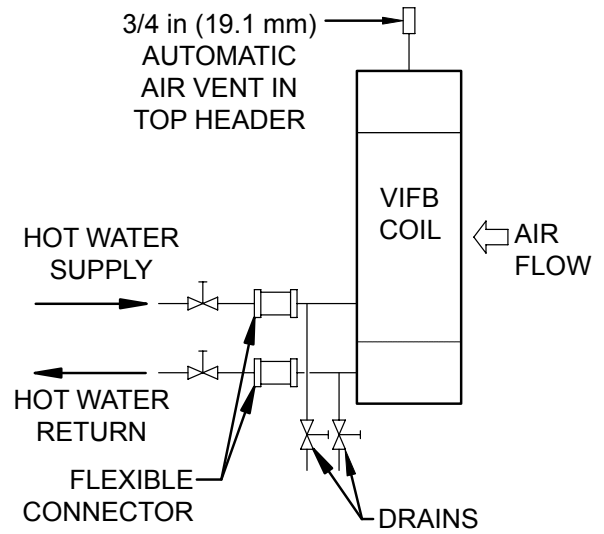

LD09632

FIGURE 63 - HOT WATER PIPING SCHEMATIC FOR 2-ROW COIL VIFB

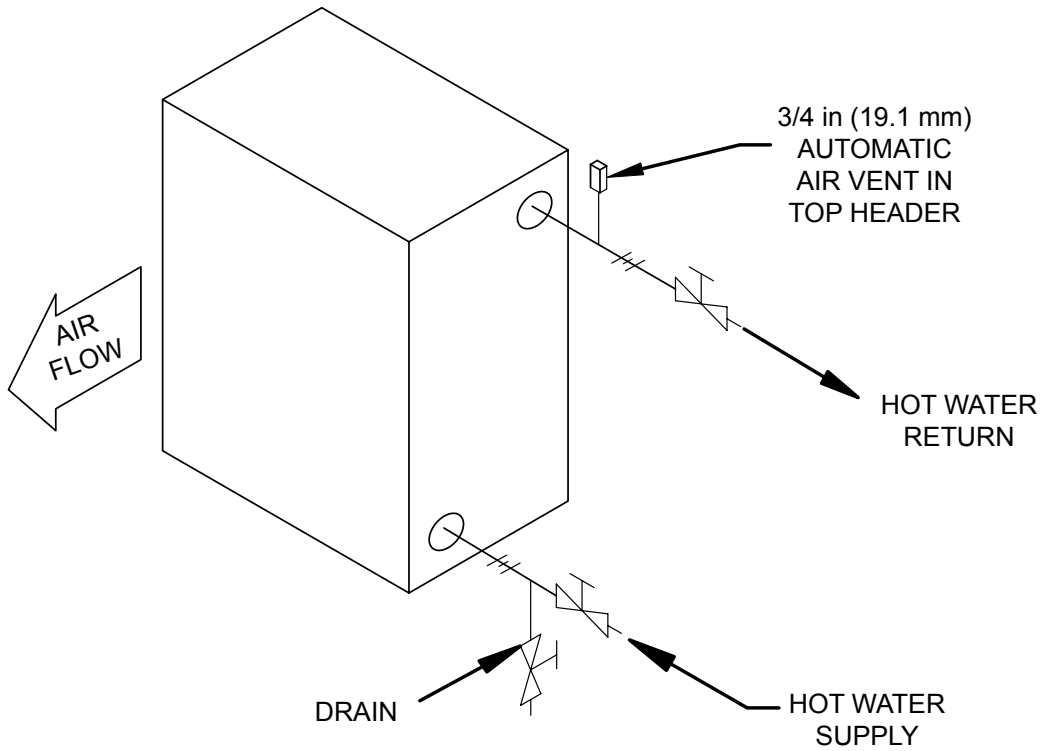

LD09633

FIGURE 62 - HOT WATER PIPING FOR IFB

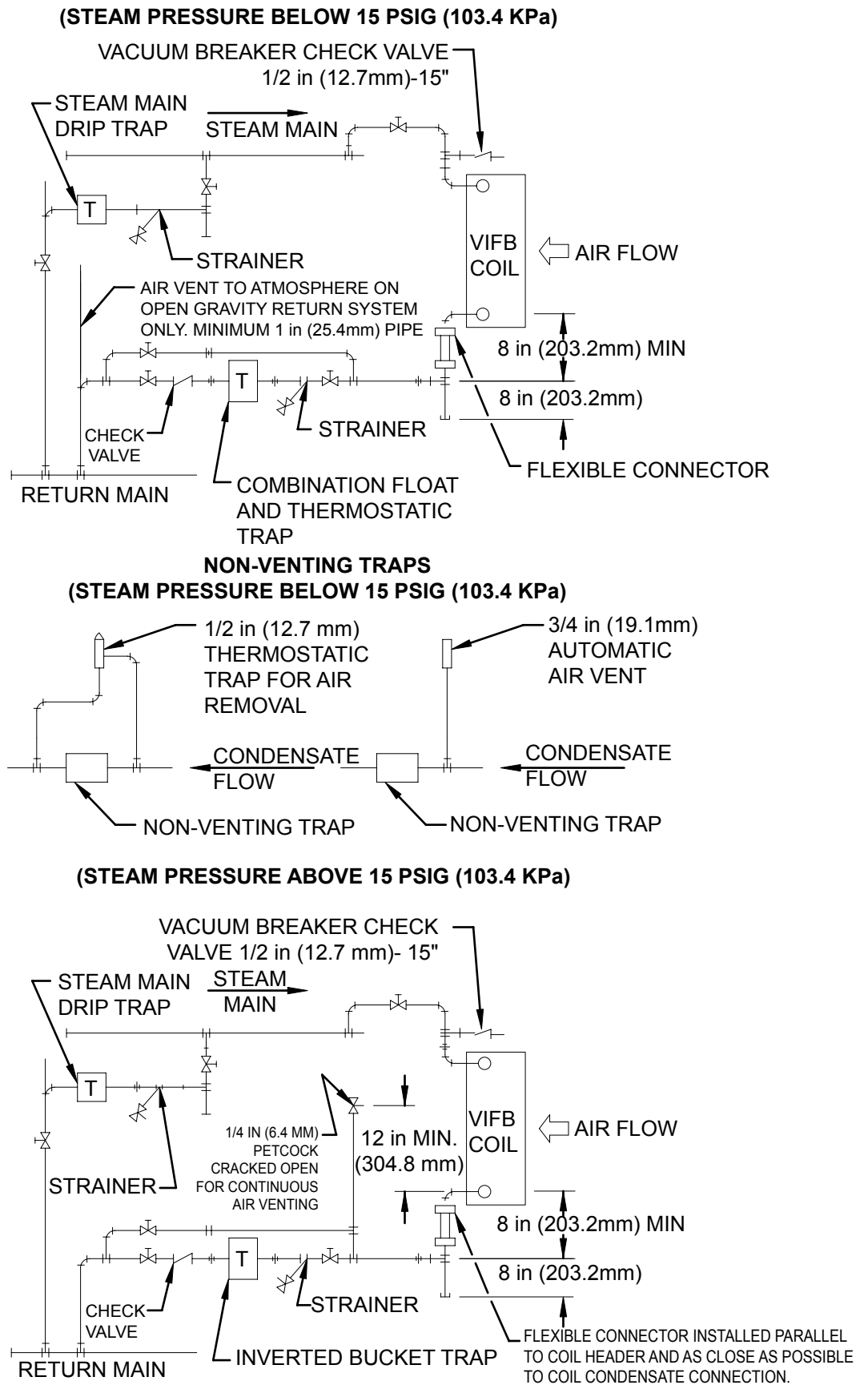

LD09634

FIGURE 64 - STEAM PIPING FOR VIFB

REFRIGERATION

DX Direct Expansion Coils

DX coils are often divided into splits, depending upon the AHU size and coil circuiting. Each split requires its own distributor nozzle, expansion valve and suction piping. Suction headers are on the air entering side with suction connection at the bottom end of the headers when the coil is properly installed. Matching distributor connections for each coil refrigeration circuit are on the air leaving side. Refer to the drawing and/or connection labeling to ensure the suction and distributor connections are matched correctly.

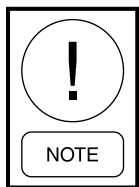

Direct expansion coils are shipped charged with nitrogen.

Do not leave the piping open to the atmosphere unnecessarily. Water and water vapor are detrimental to the refrigerant system. Until the piping is complete, recap the system and charge with nitrogen at the end of each day. Clean all piping connections before brazing the joints.

The orientation of the refrigerant distributor is not critical, but the distributor tubes must not be kinked or bent in a non-uniform configuration. For other piping and sundry tips, refer to *Figure 65 on page 67*.

DX Coil Types

Three types of coil arrangements are used in field mounted split systems: interlaced, row split and face split.

Interlaced - These coils are the most desirable type of coil field mounted designs. Interlaced coils ensure the entire face of the coil is active with any number of operating compressors. Interlaced circuitry interweaves the coil tubing in both circuits across the entire face of the coil, assuring uniform cooling of the air by the refrigerant. This type of coil also allows one circuit to operate while the other circuit is turned off. Interlaced coils provide excellent temperature control at full and part loads as well as good thermal expansion valve (TXV) superheat control, which is essential for compressor reliability.

Row Split - Row split coils arrangements place coils back-to-back in the air stream. Air passes through one coil before passing through the next coil. Generally, the last coil in the air stream is activated first. Each circuit may be controlled independently in this arrangement. When both coils are operating, the coil closest to the leaving air will operate at a lower temperature. This type of coil may not permit lead lag of the circuits and it may be difficult to balance the capacity between the coils.

Face Split - On this coil, the circuiting is divided between two separate coils. In field mounted systems, this arrangement may suffer from TXV superheat control problems and compressor reliability. At low airflow, low load situations, the TXV may have difficulty controlling the system's superheat.

Air stratification, poor humidity control, and condensation on downstream components can also occur when using face split coils. One way to address TXV control at part load is to provide a face damper to shut off airflow when a coil face is inactive.

Combined Coil Types

Coil types may be combined in some systems, which requires special care. Control sequences and piping tying the multiple systems and coils together should be well thought out. Advice from an experienced design engineer may be necessary.

DX Coil Circuiting

On many coil banks, two, or all three circuiting methods may be combined, depending upon the cooling capacity, and the level of control required. However, coil sections must be combined so that they provide full-face operation as shown in *Figure 66 on page 67*.

Refer to *Figures 67 and 68 on page 68* for the available standard and special quote arrangements from the Johnson Controls coil marketing group.

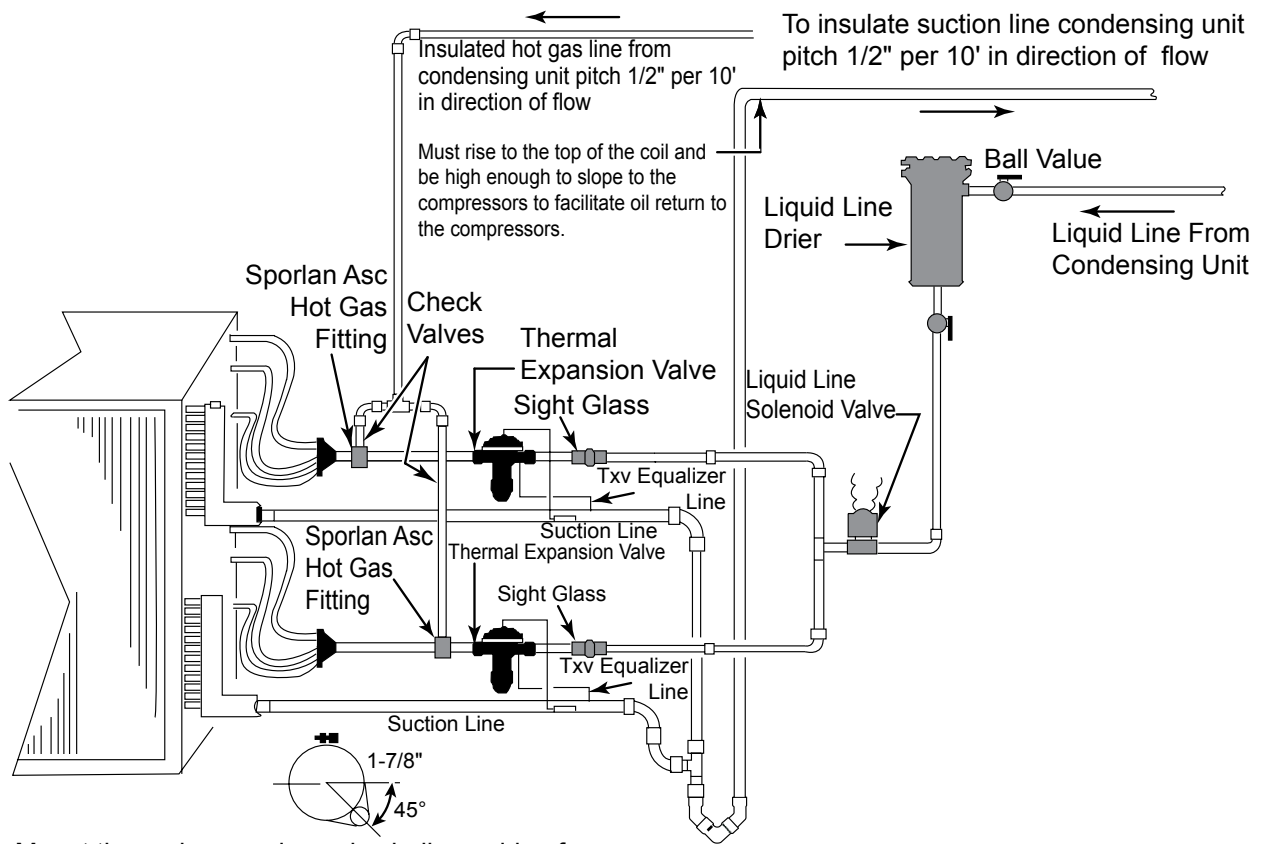

Mount thermal expansion valve bulb on side of horizontal run of suction line as shown. Insulate bulb / line after clamping bulb to line.

Construct suction line P-trap from street fittings to maintain minimum trap volume.

LD05171a

FIGURE 65 - TYPICAL PIPING AND SUNDRIES AT THE DX COIL

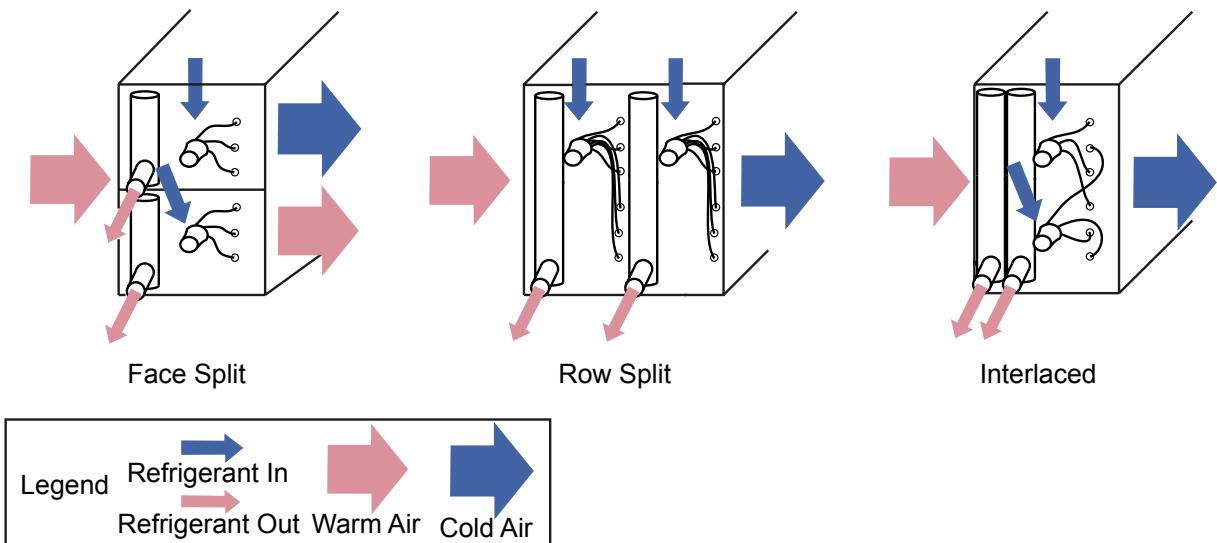

LD03319b

FIGURE 66 - DX COIL CIRCUITING TYPES

Available Coil Arrangements

Figure 67 on page 68 through Figure 70 on page 69 illustrate the available coil arrangements. Contact the Johnson Controls coil marketing group for other arrangements not shown.

Configure face-split DX coils to provide full-face coverage at all condensing AHU load steps. Johnson Controls assumes no responsibility for compressor failure, if full face coverage is not applied. Consult the Johnson Controls factory if application assistance is needed to convert the split face to a full face operation.

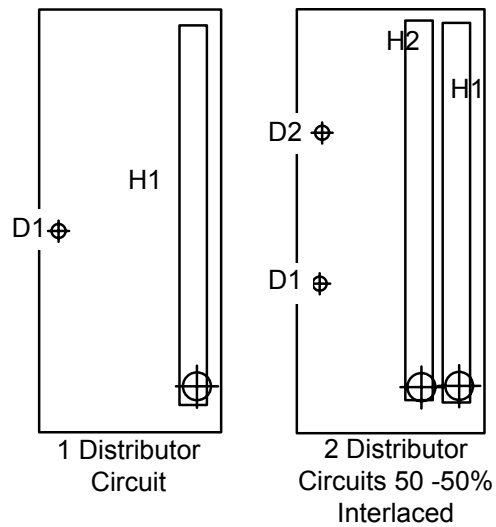

LD09143a

FIGURE 68 - NON-STACKED COIL DESIGN (STANDARD)

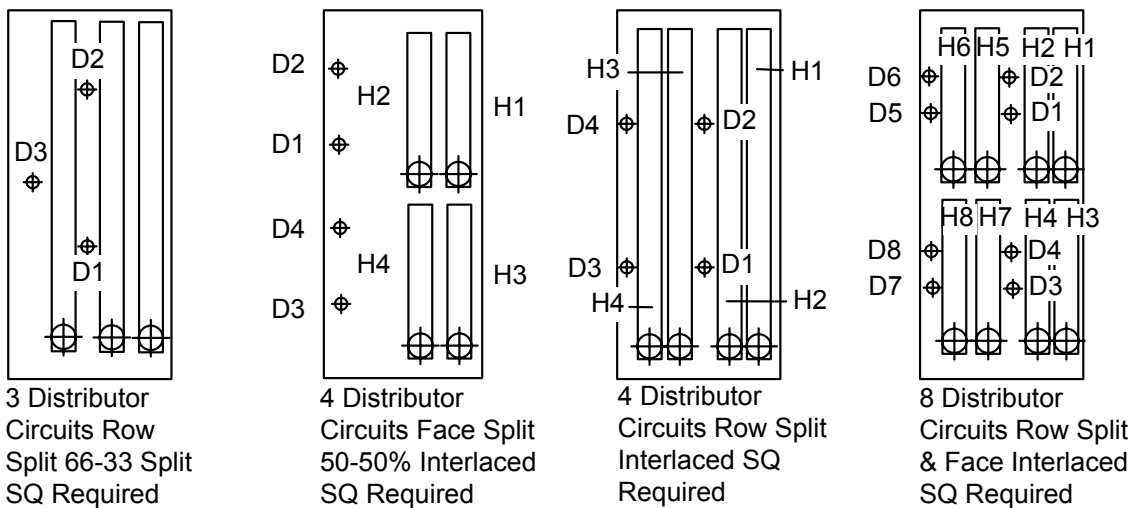
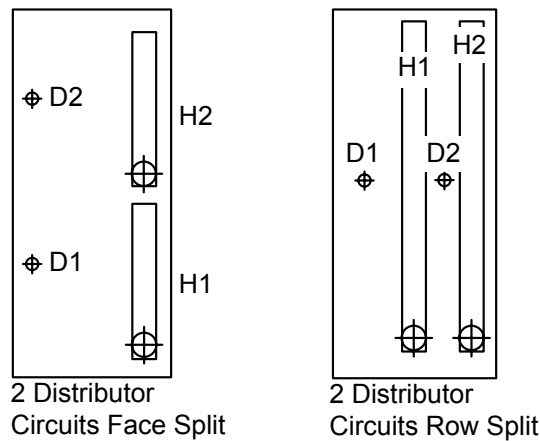

LD09144a

FIGURE 67 - NON-STACKED COIL DESIGN (SPECIAL QUOTE)

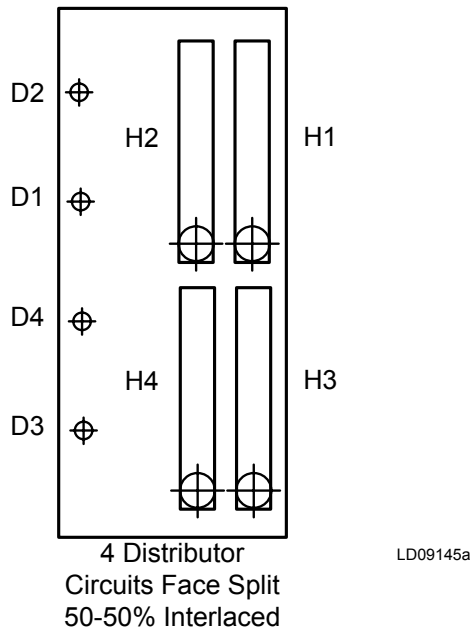

FIGURE 69 - STACKED COIL DESIGN (STANDARD)

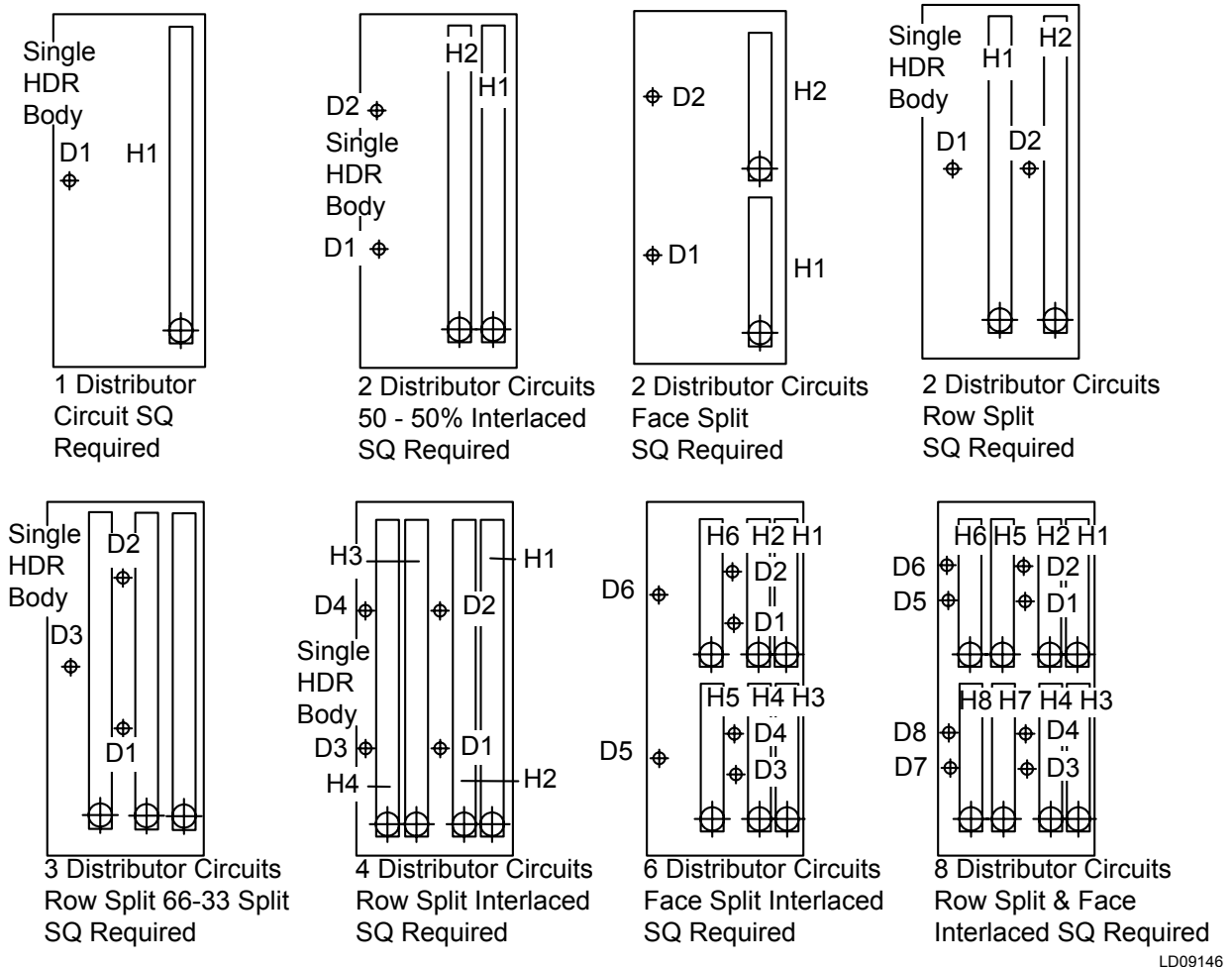

FIGURE 70 - STACK COIL DESIGNS (SPECIAL QUOTE)

THERMOSTATIC EXPANSION VALVES (TXV)

Each coil distributor circuit requires its own thermal expansion valves (TXV), and condensing AHU circuit requires its own liquid line solenoid valve (LLSV). Equip TXVs with external equalizer tubes that are field connected to the suction line. Size the valve according to the valve manufacturer's recommendations, allowing approximately 35 psi (throughout the coil and distributor at full load).

Do not oversize the valve. Follow the valve manufacturer's instructions to find the thermostatic bulb. Proper expansion valve operation is necessary in order to realize the rated coil capacity.

When a DX type coil is operated with a suction temperature below 32°F, a buildup of frost will occur on the finned surface. It is not recommended to operate DX coils for air conditioning purposes at below freezing suction temperatures. If the full load operating point for the coil is selected at a safe temperature, a system analysis is required to check for the lowest probable suction temperature at light load conditions.

HOT GAS BYPASS (HGBP)

When using discharge air temperature control or systems with outside air economizer cooling, always include hot gas bypass (HGBP). It is not as critical to use HGBP with return duct air temperature or suction pressure control, but it provides better capacity control at low loads.

The Venturi type distributor furnished with the DX coils may be ordered for field application of an HGBP. The connection may be made through a tee installed in the field between the expansion valve and distributor. The system balance point and control adjustments must assure compressor cooling and avoid excessive compressor cycling. Refer to *Guidelines for Proper Application Piping and Split Systems (Form 050.40-ES3)* for compressor staging solutions.

DX COIL CIRCUITING AND STAGING

On stacked coils, use a minimum of four coil circuits to achieve full face control as shown in *Figure 71 on page 70*. When the condensing AHU has two compressors per refrigerant circuit, one or two coil circuits may be used for each refrigerant circuit, depending upon the cooling capacity.

If one coil circuit is used as shown in *Figure 72 on page 70*, the LLSV and TXV must be sized to handle the full capacity of the refrigerant circuit. When two coil circuits are used per refrigerant circuit as shown in *Figure 73 on page 70*, each TXV should be sized to handle half of the capacity of the refrigerant circuit, and the LLSV should be sized to handle the full capacity of the refrigerant circuit.

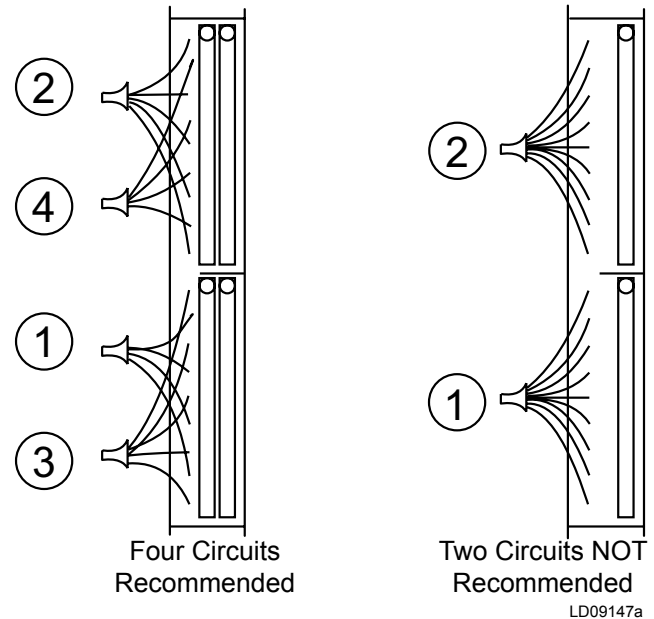

FIGURE 71 - STACKED COIL CIRCUITING

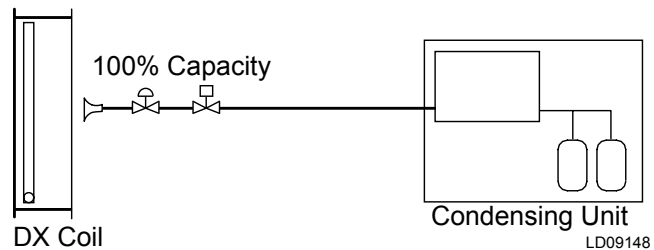

FIGURE 72 - ONE COIL CIRCUIT PER REFRIGERANT CIRCUIT

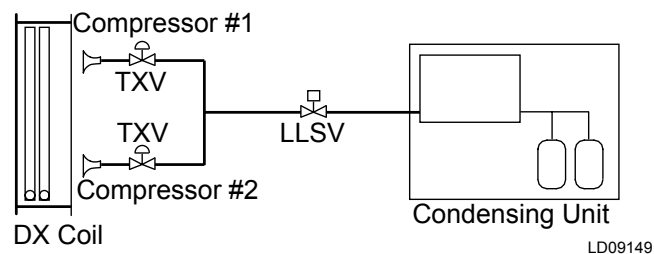

FIGURE 73 - TWO COIL CIRCUIT PER REFRIGERANT CIRCUIT

VAV SYSTEMS

Overhead VAV systems are the preferred method of air distribution because they offer greater energy efficiency and better control of building diversity than constant volume systems (CVS). Unlike a CVS, in which the leaving air temperature is adjusted to satisfy the cooling load, the air temperature in a VAV system remains constant, and the air volume is varied to meet the cooling requirements.

A VAV system has four components:

1. AHU with airflow control (i.e. Variable Frequency Drives (VFDs)),
2. VAV boxes,
3. Zone thermostats, and
4. Duct static pressure sensors.

These components must work together to provide good temperature control, and a comfortable environment.

The zone thermostats control the VAV boxes. As the zone temperature increases, the VAV boxes open to allow greater airflow into the space. As the zone temperature decreases, the VAV boxes close to decrease the airflow to the space.

As the VAV boxes open and close, the static pressure in the ductwork changes. When a box opens, the duct static pressure decreases, and when a box closes, the duct static pressure increases. The duct static pressure sensor controls the AHU supply fan. Since an increase in duct pressure relates to a decrease in the required zone airflow, the supply fan volume decreases. Conversely, a lower duct static pressure indicates a need for increased zone airflow; the supply fan volume increases. A change in supply air volume is accomplished using a VFD or similar device.

In the AHU, a decrease in airflow through the DX coil will result in a corresponding decrease in the suction gas pressure while an increase in airflow will result in an increase in the suction gas pressure. Since the system is designed to maintain a constant suction gas pressure, the compressors will be turned on or off, as needed, to meet the increase or decrease in load demand. The system should be designed to operate smoothly, avoiding transients that could upset system balance and cause liquid flood back.

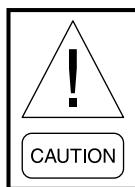

Problems can arise if the airflow decreases more quickly than the compressor control can respond to the load change. Therefore, airflow should never change at a rate faster than 3% per minute on VAV systems.

This limitation will promote stable control of the system and minimize fluctuations in zone temperature. Under any circumstances, a minimum of 350 FPM face velocity across the coil must be maintained for DX split systems.

DRAINS AND TRAPS

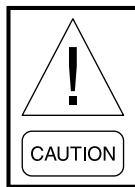

Where there is a risk of the liquid freezing in the trap, heat trace and insulate the traps to prevent blockage and/or damage.

Auxiliary drain pans may not require traps. If the trap is not in constant use, the water seal may evaporate, causing air passage into or out of the AHU. In these cases, it is recommended to cap the drain that allows the opening or closing of the drain, depending on its use.

Condensate Drain Piping

The majority of cooling coils are located in the AHUs, so that the supply air is drawn through them, which results in the condensate being subjected to negative (-) static pressure. Unless pressure equalization is provided in the condensate drain, the air rushing back through the drain pipe will cause the condensate to build up in the drain pan.

As the AHU continues to operate, the accumulated water will be carried with the air stream, overflowing the drain pan, causing possible water leaks into the supply duct and/or causing water damage in the building. Install a trap to prevent this condensate water buildup as shown in *Figure 76 on page 73*.

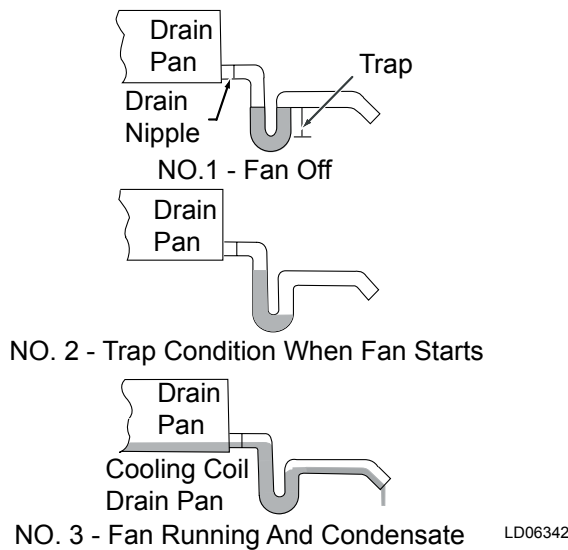

FIGURE 76 - DRAIN TRAP SHOWING WATER LOCATION FOR DRAW THROUGH OPERATION

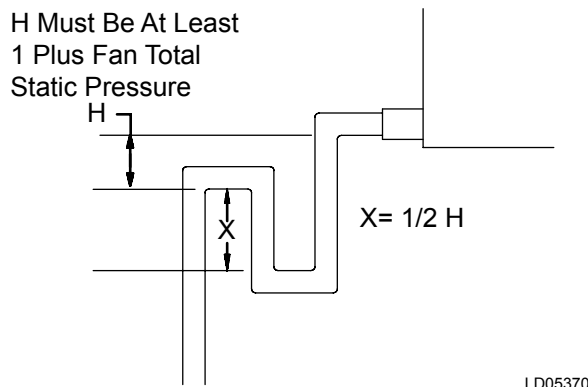

FIGURE 77 - TRAP DETAIL FOR DRAIN PAN IN NEGATIVE ENVIRONMENT (DRAW THROUGH)

Condensate Drain Trap

For Draw Through applications, install a trapped condensate drain line at the AHU drain connection as shown in *Figure 77 on page 73*, according to all codes. The *H* dimension must be at least 1 in. greater than the design TSP of the fan, which ensures proper drainage even if filters clog or dampers malfunction.

For Blow Through applications, the same principles apply, but the leaving pipe should be as shown in *Figure 78 on page 73* for proper trap design.

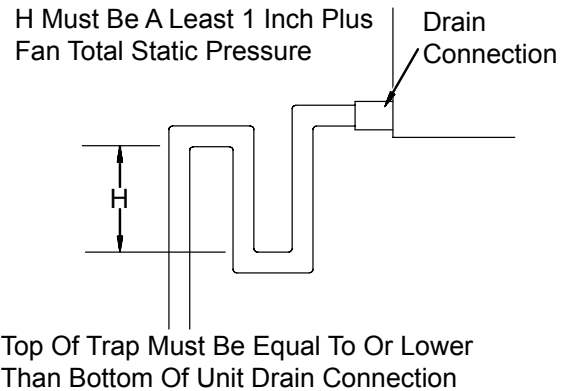

FIGURE 78 - TRAP DETAIL FOR DRAIN PAN IN POSITIVE ENVIRONMENT (BLOW THROUGH)

Two or more drains on the same side of AHU must be trapped individually before the drain lines can be combined and routed to a suitable drain as shown in *Figure 79 on page 73*.

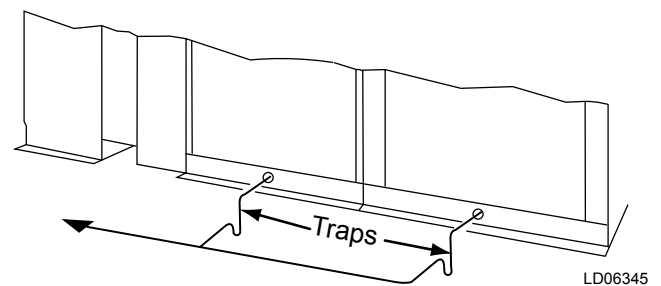

FIGURE 79 - COMBINING DRAIN LINES

If the distance from the drain pan outlet to the trap exceeds 10 ft, install additional clean outs for each 10 ft segment of horizontal drain line (min. 1/4 in per foot fall required). On initial start-up, it may be necessary to fill the trap manually.

Elevating AHU for Gravity Floor Drain Connections

On indoor AHUs, the installer must provide a method to pump or drain the coil condensate water away from the AHU. The installer may have to elevate the AHU to provide space below the condensate drain of the AHU to properly install the designed drain trap(s) to permit gravity flow of condensate water from the drain pan as shown in *Figures 9 and 10 on page 26*.

DUCT CONNECTIONS

The duct must have a positive seal to the AHU openings. Outdoor bases are available in 6, 8, 10, or 12 in. height. It is the contractor's responsibility to provide the ductwork, which includes the base rail height, and support it independently from the AHU.

Duct Connection Guidelines

The duct connection guidelines are as follows:

- Duct connections to the AHU may be made directly except when the AHU has external isolation. Then the duct connections should be made with flexible material, and be installed so they are sufficiently loose.
- Duct connections should be designed and installed according to AMCA Standards 200 and 201, at a minimum.
- Duct turns and transitions must be made carefully to hold friction loss to a minimum. Avoid short turns. Duct elbows should contain splitters or turning vanes.
- The effective duct length connected to the fan or AHU discharge should run in a straight line for at least 2.5 equivalent discharge diameter for up to 2500 FPM fan outlet velocity and one additional diameter for each additional 1000 FPM fan outlet velocity.
- Ductwork should be no greater than 105.5% or no less than 85.5% of the discharge area. The slope of the transition elements should not be greater than 15% for converging elements, or greater than 7% for diverging elements.
- To find the equivalent discharge diameter, use the following equation, where a = height, and b = width of the discharge:

$$EDD = \sqrt{4ab/\pi}$$
- A duct turn should be in the same direction as the fan rotation as shown in *Figure 80 on page 74*. Never deadhead the discharge into the flat surface of a plenum.

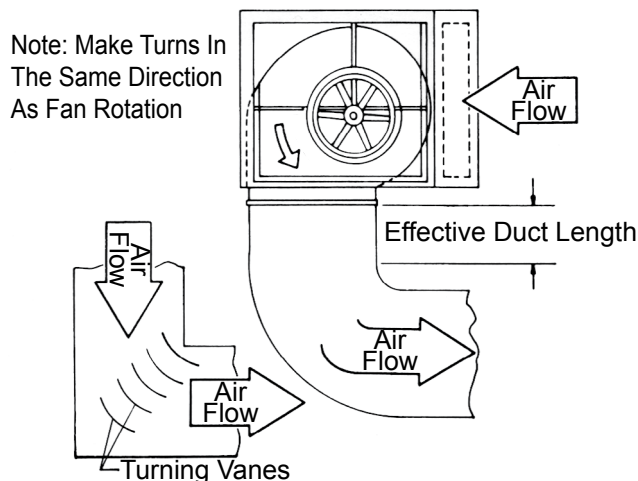

LD06335

FIGURE 80 - RECOMMENDED DISCHARGE DUCT ARRANGEMENT WHEN TURNS ARE REQUIRED

Flanged Duct or Sleeves

To use flanged ducts or sleeves, make sure there is access on all four sides to fasten the flange completely.

Connect the flanged ducts with self-drilling screws directly to the AHU with a gasket or sealant between the AHU, and the duct flange as shown in *Figure 81 on page 75*. A flange may be dropped through the opening, if there is access to seal and fasten the flange to the AHU's interior surface.

Raw or Straight Edge Duct or Sleeves

The duct opening on the AHU is located in a panel about 2 in. thick, which is suitable for attaching ducts.

If access is not available from the inside of the AHU, access may have to be gained from inside of the duct or sleeve.

Connect the raw or straight edge ducts with the self-drilling screws directly to the AHU with a gasket or sealant between the AHU and the duct flange as shown in *Figure 81 on page 75*.

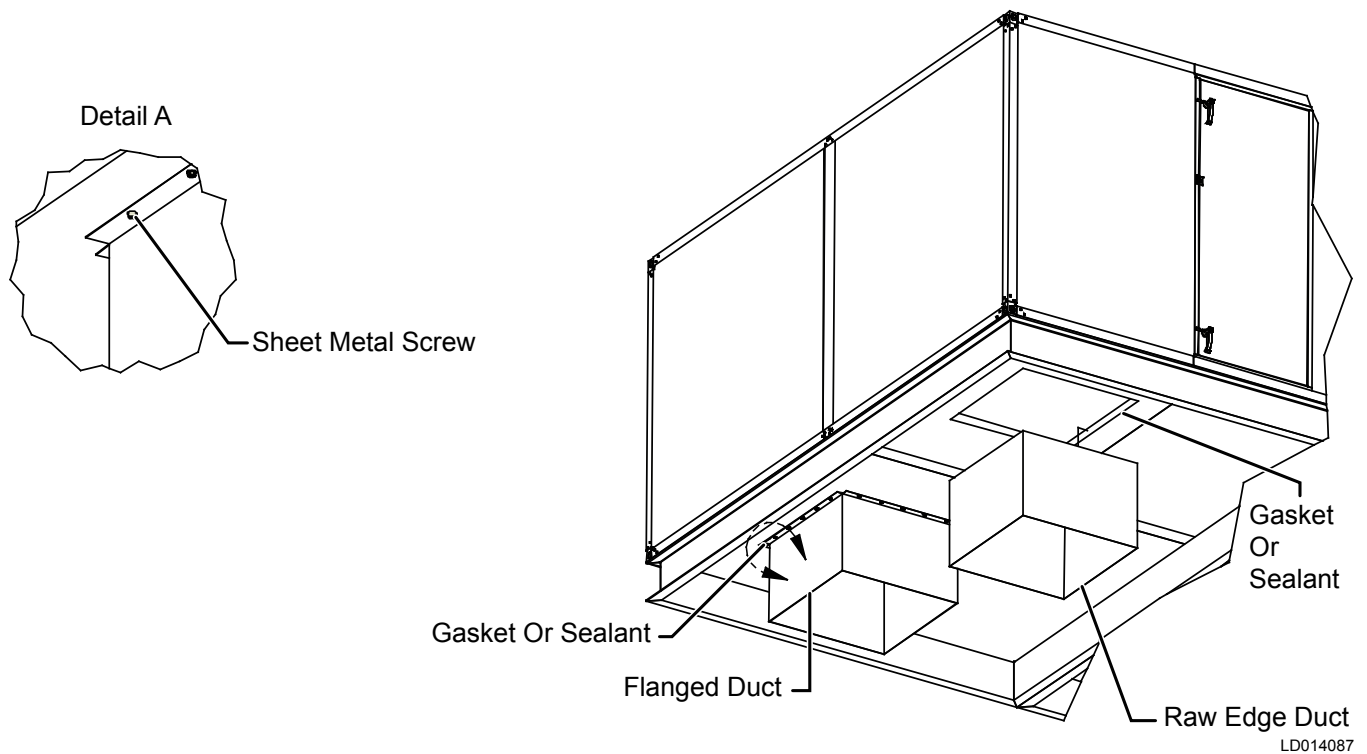

FIGURE 81 - DUCT ARRANGEMENT FOR FLANGE AND RAW EDGE DUCTS

The performance ratings of coils will be met only if the airflow is uniform over the face of the coils. High air velocity spots on the coil may cause carryover of moisture from the coil. High or low air velocity areas of the coil will not deliver the published ratings. The duct connections must be designed to provide for uniform flow of air across the face of the coil. The entering duct must provide a smooth transition from any high velocity effects. Stratifications of outside and return air, especially where below freezing outside air enters, must be avoided to prevent coil freeze-up or nuisance low limit trips.

Sound and Vibration Transmission

All roof-mounted AHUs generate some sound and vibration, which may or may not require special treatment of the air-conditioned space. The noise generated by the AHU depends on the following:

- Speed of the fan,
- Amount of air the fan is moving,
- Fan type, and
- Static efficiency of the fan.

In applications where sound and vibration transmissions may be objectionable, good acoustical engineering practices must be incorporated in the system design. On AHUs with return fans, it is important to consider the effects of sound transmission into the air-conditioned space.

When a AHU is used with a ceiling plenum return air system, sound may be transmitted from the AHU through the ceiling to the air-conditioned space. For such applications, install a sound absorption chamber near the AHU return air inlet. Various reference sources are available regarding acoustic design.

Installing Top Discharge Outdoor AHU Duct

For outdoor AHU top duct connection, the installer is responsible for sealing the duct to the roof panel. The installer should not seal the duct to the unit opening.

Installing Front and Rear Discharge Outdoor AHU Duct

Use the following instructions to install the front and rear discharge outdoor AHU duct.

- Building roof penetrations by ducts should utilize counter flashed curbs as shown in *Figure 82 on page 76*.

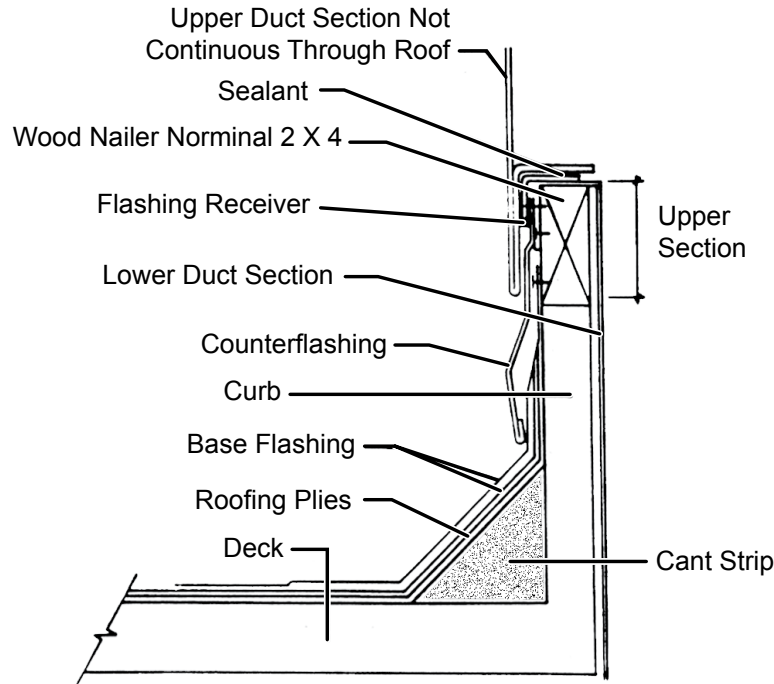

LD06494a

FIGURE 82 - DUCT PENETRATION OF ROOF

- Seal all penetrations into the ducts until watertight. Use a minimum of duct penetration when attaching the supports.
- Provide adequate clearances between the ducts and roof penetration openings.
- Duct systems should not be pressurized without sufficient time for curing the sealant systems. Follow the sealant manufacturer's recommendations for applying the sealant.
- Support the ducts to avoid the transfer of duct weight across flexible connections as shown in *Figure 83 on page 76*.
- Horizontal ducts should be pitched and provided with drainage outlets.
- Install the ducts at a height sufficient to install roofing and flashing. Refer to the *Duct Connection Guidelines on page 74* for more information.

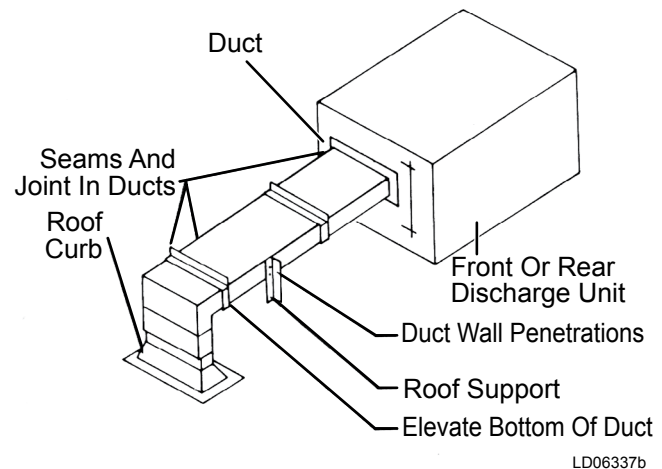

LD06337b

**FIGURE 83 - ROOF TO DUCT INSTALLATION
(HORIZONTAL DISCHARGE)**

AIR FILTERS

Filters **MUST** be in place in the filter frames before putting the AHU into operation to protect and keep the coils clean. Due to the wide variety of filters, it is not possible to cover all filter types. Refer to *Figure 85 on page 78* for typical filter types.

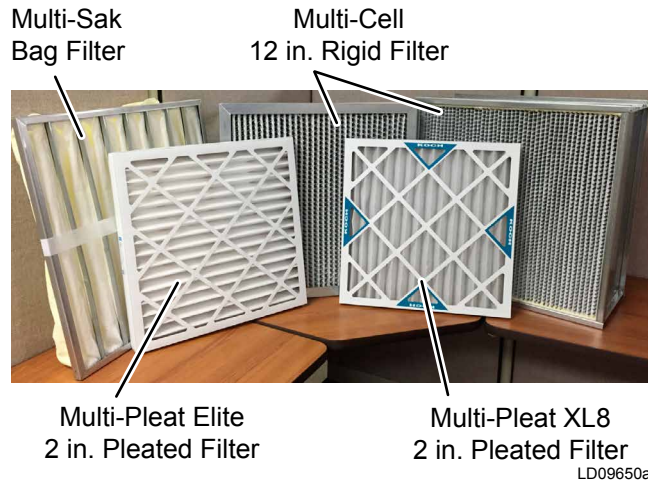

FIGURE 84 - TYPICAL FILTER TYPES

Install the filters in the correct orientation with regard to airflow and with pleats or pockets vertically, wherever possible. Refer to the *Air Handling Units - Operation and Maintenance Manual (Form 102.20-OM2)* for more information.

Most AHUs will be shipped without filters. The Johnson Controls sales office is responsible for ordering and delivering the filters in a timely manner. The contractor or commissioning agent must contact Johnson Controls regarding this issue because various filter types will have different lead times.

Filter latches as shown in *Figure 85 on page 78*, if required, will be shipped with the first filter shipment, except for HEPA filters. The HEPA filter latches will be attached to the filter racks inside of the AHU. Filter latches are not required for side load filter arrangements.

The contractor is responsible for installing the filters, and for freight claim, if the filters arrive damaged. Address other issues such as size, type, spares, replacements, or quantity with the Johnson Controls sales office. Filter types are:

- Flat
- Angle
- Rigid
- Charcoal
- HEPA

Maintaining and Replacing Filters

Every month, check the cleanliness of the filters and replace, if necessary. Replace the filters when the pressure, measured by a manometer, reaches the prescribed limits for the installation.

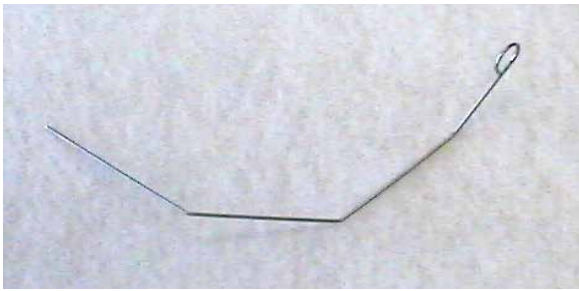

P/N - 026-35788-702

Used with 2 in. pre-filter and SH Single Header Final Filters.



P/N - 026-35788-604 (C86)
P/N - 026-35788-605 (C89)

Used with 2 in. (C86) and 4 in. (C89) pre-filter combined with a Single Header Final Filter

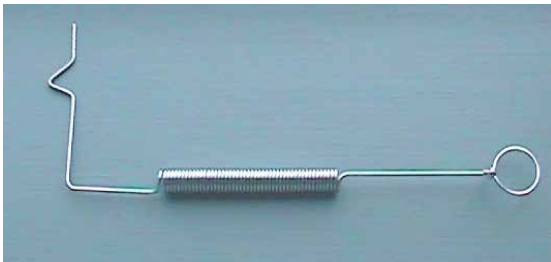

P/N - 026-35788-612

Used with 2 in. and 4 in. pre-filter combined with a double header (DH) final filter

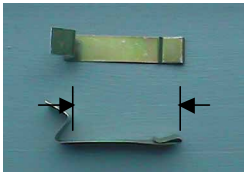

P/N - 026-35788-625

Used with 2 in. Pre-filter Combined with a DH Final Filter.

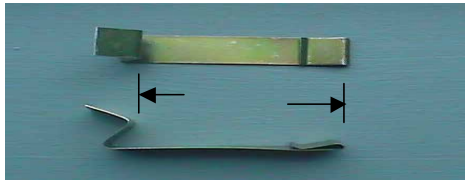

P/N - 026-35788-626

Used with 4 in. Pre-filter Combined with a DH Final Filter.

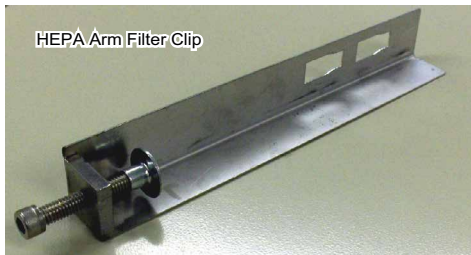

Used to Attach HEPA Filters to Holding Frame.

LD13303c

FIGURE 85 - FILTER LATCHES

TABLE 4 - KOCH FILTER CLIPS - SINGLE FILTER APPLICATION

	2 IN MICROMAX	4 IN MICROMAX	MULTI-CELL FM SINGLE HEADER (SH) OR MULTI-SAK	MULTI-CELL SBM DOUBLE HEADER (DH)
P/N 026-35778-702	X		X	
P/N 026-35778-604		X		
P/N 026-35778-612				X

3

TABLE 5 - KOCH FILTER CLIPS - PRE-FILTER / FINAL FILTER APPLICATION

	2 IN MULTI-PLEAT ELITE OR CLEANABLE OR THROWAWAY AND MULTI-CELL FM SINGLE HEADER (SH) OR MULTI-SAK	2 IN MULTI-PLEAT ELITE OR CLEANABLE OR THROWAWAY AND MULTI-CELL SBM DOUBE HEADER	4 IN MULTI-PLEAT XL8 AND MULTI-CELL FM SINGLE HEADER (SH) OR MULTI-SAK	4 IN MULTI-PLEAT ELITE AND MULTI-CELL SBM DOUBLE HEADER
P/N 026-35778-702 and 026-35778-604	X			
P/N 026-35778-612 and 026-35778-625		X		
P/N 026-35778-702 and 026-35778-605			X	
P/N 026-35778-612 and 026-35778-626				X

Note: When filters are supplied by other companies, the filter clips are supplied as well.

TABLE 6 - AAF CLIPS FOR FILTER FRAMES - SINGLE FILTER APPLICATION

	2 IN PERFECTPLEAT, PREMIUM OR PREMIUM HM	4 IN AMAIR 300X	VARICEL SINGLE HEADER (SH) OR DRIPAK 2000	VARICEL DOUBLE HEADER (DH)
FILTER FRAME 12X24 - 16 G GALVANIZED				
P/N 026-35778-000	X		X	
P/N 026-35778-007		X		
P/N 026-35778-006				X
FILTER FRAME 24X24 - 16 G GALVANIZED				
P/N 026-35778-000	X		X	
P/N 026-35778-007		X		
P/N 026-35778-006				X

TABLE 7 - AAF PRE-FILTER/FINAL FILTER APPLICATION

	PERFECTPLEAT, PREMIUM OR HM AND VARICEL SH OR DRIPAK 2000	PERFECTPLEAT, PREMIUM OR HM AND VARICEL DH	4 IN AMAIR 300X AND VARICEL SH OR DRIPAK 2000	4 IN AMAIR 300X AND VARICEL DH
FILTER FRAME 12X24 - 16 G GALVANIZED				
P/N 026-35778-007 and 026-35778-000	X			
P/N 026-35778-006 and 026-36339-001		X		
P/N 026-35778-007, 026-35778-008 and 026-35778-000			X	
P/N 026-35778-006 and 026-36339-000				X
FILTER FRAME 24X24 - 16 G GALVANIZED				
P/N 026-35778-007 and 026-35778-000	X			
P/N 026-35778-006 and 026-36339-001		X		
P/N 026-35778-007, 026-35778-008 and 026-35778-000			X	
P/N 026-35778-006 and 026-36339-000				X

Note: When filters are supplied by other companies, the filter clips are supplied as well.

Filter Installation

Installing a 2 in. Pleated Filter

Use the following instructions to install a 2 in. Multi-Pleat Elite filter into a 16 g galvanized holding frame with four latches (P/N 026-35788-702), as shown in *Figure 85 on page 78*.

1. Install one latch at each corner (4 corners) of the frame. The latch fits into two rows of three knockouts. Use the row of knockouts closest to the gasket for nominal 1 in. filters or filters with a 13/16 in. single header. Use the second set of knockouts for nominal 2 in. filters.
2. Insert the straight end of the latch between the two knockouts furthest from the corner.
3. Using a moderate amount of pressure, force the latch over the third knockout. The latch should now be trapped within the three knockouts, but should be able to freely rotate as shown in *Figure 86 on page 81*.
4. The latch installation should be complete.

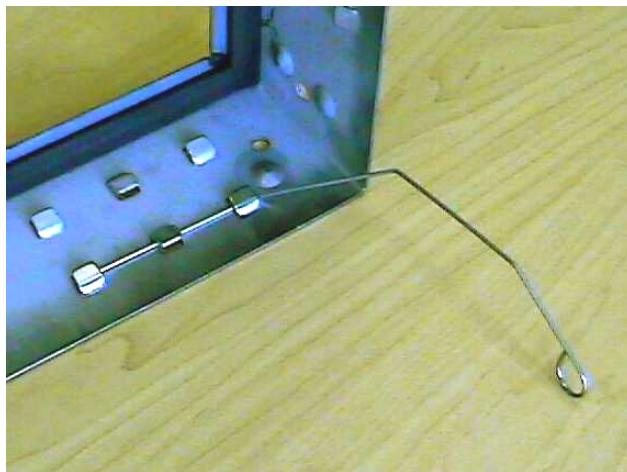

LD10171

FIGURE 86 - CORRECTLY INSTALLED LATCH PIN (P/N 026-35788-702)

5. Install the other three latches into the corners.
6. Rotate all of the latches outward, and insert the filter into the frame.
7. Grasp the circular end of the latch, and rotate it across the corner of the filter.
8. Push the end of the latch towards the filter until the latch catches beneath the knockout on the frame.
9. Repeat the process with the remaining latches.
10. The filter should now be securely installed into the frame as shown in *Figure 87 on page 81*.



LD10174

FIGURE 87 - FULLY INSTALLED FILTER

Installing a 4 in. Pleated Filter

Use the following instructions to install a 4 in. Micro-MAX filter into a 16 g galvanized holding frame with four latches (P/N 026-35778-604), as shown in *Figure 85 on page 78*.

1. Install one latch at each corner (4 corners) of the frame. The latch fits into two rows of three knockouts. Use the row of knockouts closest to the gasket for nominal 1 in. filters or filters with a 13/16 in. single header. Use the second set of knockouts for nominal 2 in. filters.
1. Insert the straight end of the latch between the two knockouts furthest from the corner.
2. Using a moderate amount of pressure, force the latch over the third knockout. The latch should now be trapped within the three knockouts, but should be able to freely rotate as shown in *Figure 88 on page 81*.
3. The latch installation should now be complete.



LD10177

FIGURE 88 - CORRECTLY INSTALLED LATCH PIN (P/N 026-35788-604)

4. Install the other three latches into the corners.
5. Rotate all of the latches outward, and insert the filter into the frame.
6. Grasp the loose end of the latch, and place it over the filter frame so that the latch secures the filter into the frame as shown in *Figure 89 on page 82*.



LD10179

FIGURE 89 - PLACE THE END OF THE LATCH OVER THE FILTER FRAME

7. Repeat the process with the remaining latches..
8. The filter should now be securely installed into the frame.

Installing a Single Headered (SH) Filter

Use the following instructions to install a 2 in. Single Headered (SH) filter into a 16 g galvanized holding frame with four latches (P/N 026-24788-702), as shown in *Figure 85 on page 78*.

1. Install one latch at each corner (4 corners) of the frame. The latch fits into two rows of three knockouts. Use the row of knockouts closest to the gasket for nominal 1 in. filters or filters with a 13/16 in. single header. Use the second set of knockouts for nominal 2 in. filters
2. Insert the straight end of the latch between the two knockouts furthest from the corner.

3. Using a moderate amount of pressure, force the latch over the third knockout. The latch should now be trapped within the three knockouts, but should be able to freely rotate.
4. The latch installation should be complete.
5. Rotate the latches outward, and insert the SH filter into the frame. Insert the bulk of the filter through the frame, protruding out the backside. Only the header of the filter should be contacting the flange of the frame.
6. After the filter is placed into the frame, grasp the circular end of the latch and rotate it across the corner of the filter.
7. Push the end of the latch towards the filter, until the latch catches beneath the frame knockout.
8. Repeat the process with the remaining latches.
9. The filter should now be securely installed into the frame as shown in as shown in *Figure 90 on page 82*.



LD10148

FIGURE 90 - CORRECTLY INSTALLED CARTRIDGE FILTER

Installing a 2 in. Pre-Filter Combined with a SH Final Filter

Use the following instructions to install a 2 in. pre-filter combined with a SH final filter (Multi-Cell FM Single Header or Multi-Sak) into a 16 g galvanized holding frame with four latches (P/N 026-35778-604), as shown in *Figure 85 on page 78*.

1. Follow the instructions for the SH filters on the previous page, and then proceed with the following instructions for 2 in. pre-filters.
2. Insert the straight end of the latch between the two knockouts furthest from the corner.

- Using a moderate amount of pressure, force the latch over the third knockout as shown in *Figure 91 on page 83*.



LD10496

FIGURE 91 - CORRECTLY INSTALLED LATCH PIN (P/N 026-35788-604)

- Grasp the loose end of the latch, and place it over the pre-filter frame, so that the latch secures the pre-filter to the SH filter.
- Repeat the process with the remaining latches.
- The filters should now be securely installed into the frame as shown in *Figure 92 on page 83*.



LD10160

FIGURE 92 - CORRECTLY INSTALLED CARTRIDGE WITH PLEATS

Installing a Multi-Cell SBM Double Headered (DH) Filter

Use the following instructions to install a Multi-Cell SBM double header (DH) filter (nominal 12 in.) into a 16 g galvanized holding frame with four latches (P/N 026-35788-612), as shown in *Figure 85 on page 78*.

- Install the two latches on each side of the frame, not on the top or bottom. Refer to the sets of knockouts in *Figure 93 on page 83* that should be used for the latches.



LD10150

FIGURE 93 - CORRECT USE OF KNOCKOUTS

- Insert the straight end of the latch between the two knockouts furthest from the corner.
- Using a moderate amount of pressure, force the latch over the third knockout.
- The latch installation should be complete. The latch should now be trapped within the three knockouts.
- Repeat the steps with the remaining latches. Note the orientation of the latch to the knockouts as shown in *Figure 94 on page 83*.



LD10154

FIGURE 94 - CORRECT LATCHOUT/KNOCKOUT CONFIGURATION

- After the latches are installed, the frame should be configured as shown in *Figure 95 on page 84*, which shows there are two latches per side, none on the top or bottom.



LD10183

FIGURE 95 - FRAME WITH FOUR LATCHES INSTALLED ON THE SIDES

7. Insert the Multi-Cell SBM DH filter into the frame. While holding the filter in the frame, grasp the loop on the end of the latch, and pull it until it stretches over the header, and rests into the pre-drilled hole in the header as shown in *Figure 96 on page 84*.
8. Repeat this step with the remaining latches.



LD10184

FIGURE 96 - SPRING LATCH PULLED AND FASTENED IN FILTER HOLE

9. The filter should now be securely installed into the frame.

Installing a 2 in. and 4 in. Pre-Filter Combined with a DH Final Filter

Use the following instructions to install a 2 in or 4 in Multi-Pleat Elite or MicroMAX pre-filter combined with a Multi-Cell SBM DH (nominal 12 in. deep) final filter into a 16 g galvanized holding frame. Use the following latches to install the filter and pre-filter:

- Four spring latches (P/N 026-35788-612) to hold the Multi-Cell SBM DH into the frame,
 - Four pre-filter latches (P/N 026-35788-625) to hold the 2 in. latch, and
 - Four pre-filter latches (P/N 026-35788-626) to hold the 4 in. pre-filter onto the face of the Multi-Cell SBM DH filter.
1. Install the two latches on each side of the frame, not on the top or bottom.
 2. Insert the straight end of the latch between the two knockouts furthest from the corner.
 3. Using a moderate amount of pressure, force the latch over the third knockout.
 4. The latch installation should now be complete. The latch should now be trapped within the three knockouts as shown in *Figure 97 on page 84*.



LD10154

FIGURE 97 - CORRECT LATCHOUT/KNOCKOUT CONFIGURATION (P/N 026-35788-612)

5. Repeat the steps with the remaining latches. Note the orientation of the latch to the knockouts as shown in *Figure 97 on page 84*.
6. Insert the Multi-Cell SBM DH filter into the frame. While holding the filter in the frame, grasp the loop on the end of the latch, and pull it until it stretches over the header, and rests into the pre-drilled hole in the header as shown in *Figure 98 on page 85*.



LD10184

FIGURE 98 - SPRING LATCH PULLED AND FASTENED IN FILTER HOLE

Installing Pre-Filter Latches

1. To install the pre-filter latches, slide the end of the latch with a 180° turn over the edge of the header, as shown in *Figure 99 on page 85*. Install the latch at the approximate midpoint of the filter leg. The pre-filter latch should be slid over the header as shown in *Figure 99 on page 85*.



LD10163

FIGURE 99 - INSTALLING PRE-FILTER LATCH

2. Repeat the steps for the remaining pre-filter latches.
3. Place the pre-filter against the face of the Multi-Cell SBM DH filter. The pre-filter latches may have to be re-positioned as shown in *Figure 100 on page 85*, to allow the proper placement of the pre-filter.



LD10165

FIGURE 100 - POSITION PRE-FILTER IN FRONT OF FINAL FILTER

4. Grasp the end of the pre-filter latch and spring it, so that it fits over the edge of the pre-filter as shown in *Figure 101 on page 85*.
5. Repeat this step with the remaining latches.

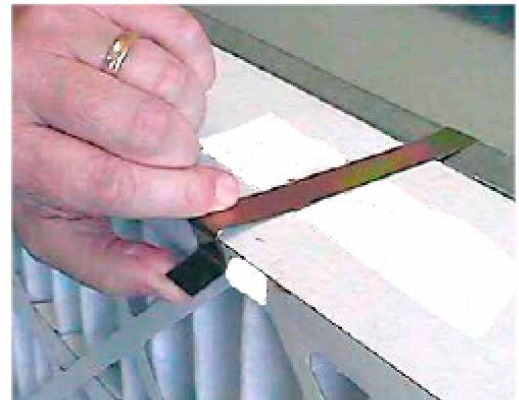

LD10190

FIGURE 101 - SPRING END OF LATCH

After placing all remaining pre-filter latches around the pre-filter; the finished assembly should look like the one shown in *Figure 102 on page 85*.



LD10187

FIGURE 102 - COMPLETED ASSEMBLY

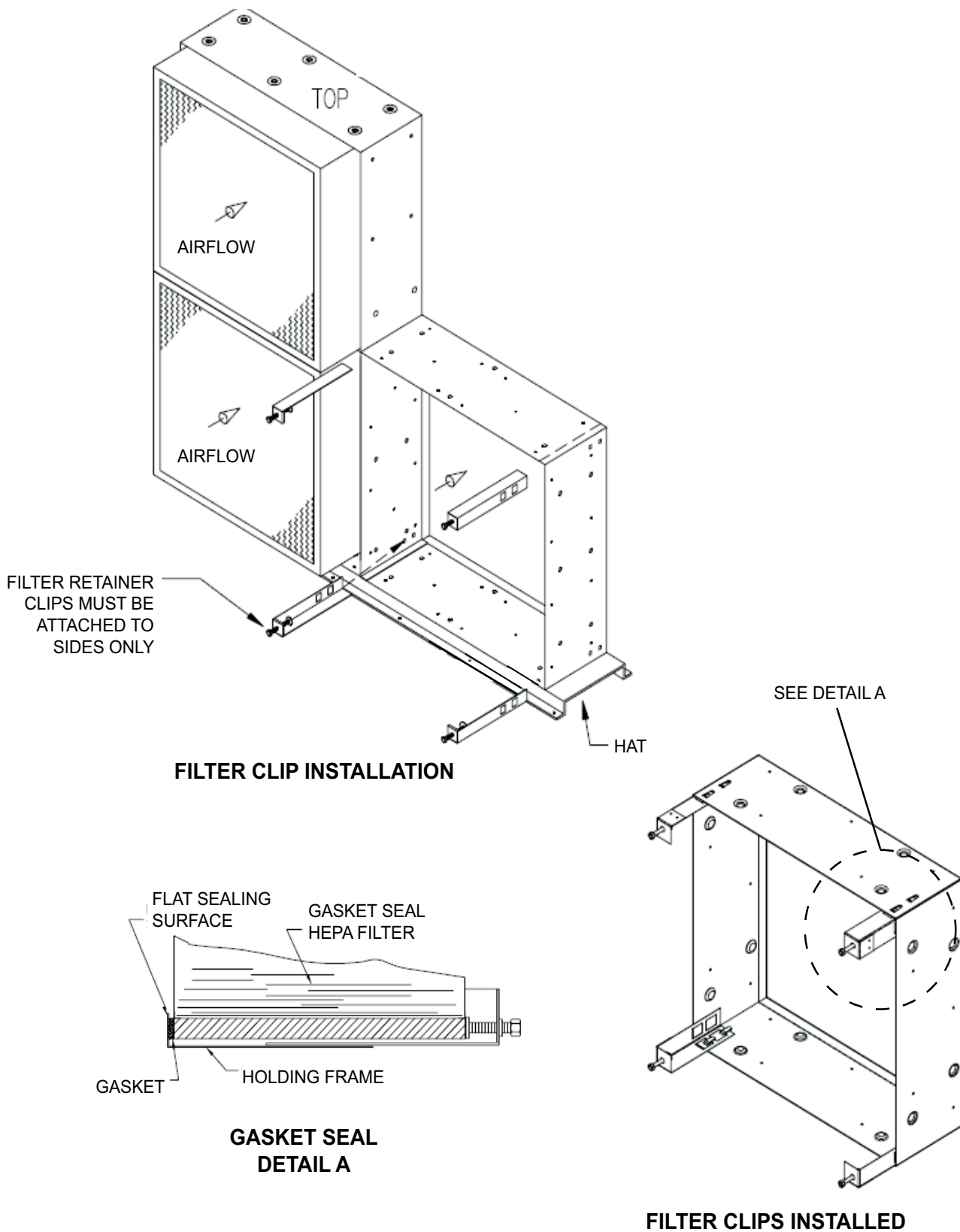

FIGURE 103 - INSTALLATION OF HEPA FILTERS

The following factors can be used to convert from English to the most common SI Metric values.

TABLE 8 - SI METRIC CONVERSION

MEASUREMENT	MULTIPLY ENGLISH AHU	BY FACTOR	TO OBTAIN METRIC AHU
Capacity	Tons Refrigerant Effect (ton)	3.516	Kilowatts (kW)
Power	Horsepower	0.7457	Kilowatts (kW)
Flow Rate	Gallons / Minute (gpm)	0.0631	Liters / Second (l/s)
Length	Feet (ft)	0.3048	Meters (m)
	Inches (in)	25.4	Millimeters (mm)
Weight	Pounds (lbs)	0.4538	Kilograms (kg)
Velocity	Feet / Second (fps)	0.3048	Meters / Second (m/s)
Pressure Drop	Feet of Water (ft)	2.989	Kilopascals (kPa)
	Pounds / Square In. (psi)	6.895	Kilopascals (kPa)

TEMPERATURE

To convert degrees Fahrenheit (°F) to degrees Celsius (°C), subtract 32° and multiply by 5/9 or 0.5556.

Example: $(45.0^{\circ}\text{F} - 32^{\circ}) \times 0.5556 = 7.22^{\circ}\text{C}$

To convert a temperature range (i.e., a range of 10°F) from Fahrenheit to Celsius, multiply by 5/9 or 0.5556.

Example: $10.0^{\circ}\text{F range} \times 0.5556 = 5.6^{\circ}\text{C range}$



P.O. Box 1592, York, Pennsylvania USA 17405-1592
Copyright © by Johnson Controls 2015
Form 102.20-N3 (615)
Issue Date: June 1, 2015
New Release

800-861-1001
www.johnsoncontrols.com

Subject to change without notice. Printed in USA
ALL RIGHTS RESERVED