



Form 090-022 0 (AUGUST 2009)

OPERATION - SERVICE

File: SERVICE MANUAL - SECTION 90
Replaces: S90-022 0/MAY 2007
Dist: 3. 3a. 3b. 3c

OPERATION – SERVICE
(SESSION LEVEL 2)

FRICK[®] QUANTUM[™] LX
COMPRESSOR
CONTROL PANEL
Version 6.6x

TABLE OF CONTENTS

TYPICAL SYSTEM CONFIGURATION	4
OVERVIEW OF OPERATOR INTERFACES	4
QUANTUM™ LX CONTROL PANEL	4
Keys and Key Functions	5
Web Browser	6
CHANGING SETPOINTS	6
MENU STRUCTURE	7
OPERATING DISPLAY SCREENS	8
Operating Status (Home)	8
Operating Values	
Sequencing	11
User Defined Operating Status	14
Vyper	
Vyper	15
Harmonic Filter	15
Modes	16
Safeties	
History - Current Safeties	17
History - Safety History	18
System Status	
Trending Setup	19
Real Time Trending	20
History Trending	21
Real Time Data Log	22
Maintenance	24
Event Log	25
VSD Energy Savings	26
Setpoints	
Capacity Control	27
Sequencing - System 1 Setup	29
Compressor Safeties	30
Package Safeties	32
Drive	35
Miscellaneous	37
Scheduling	38
Condenser	
Digital Control	39
Analog Control	40
PHD Monitoring	41
PID Setup	43
Setting up a PID Channel	44
Overview to Tuning a PID Controller	44
Superheat	46
Recip	47
Auxiliaries	
Analog Inputs - Page 1	48
Analog Inputs - Page 2	49
Digital Inputs	50
Digital Outputs	51
Panel	52
Calibration	
Pressure	54

Temperature	55
Capacity/Volume	56
Motor/Miscellaneous	57
PHD Monitoring.....	58
Analog Outputs	
Retransmitting Outputs.....	59
Analog Outputs.....	60
Auxiliary Analogs	
Page 1	61
Page 2	62
CONFIGURATION	
Compressor	63
Communications	65
Ethernet.....	67
Security.....	68
Session.....	69
Service	
Digital	70
Analog	70
Communications Log.....	71
ModBus TCP Log.....	72
Motor Bump.....	73
Communications Loop Back Test	74
Diagnostics	74
Software Maintenance	75
Documentation	78
Help.....	79
About	80
MISCELLANEOUS SCREENS	81
Alpha.....	81
OPERATION OVERVIEW	82
Initial Setup Procedure	82
Compressor Strat-Up Procedure.....	82
Compressor Stopping Procedure	82
Setup For Automatic Control	82
Remote Control of the Compressor	82
REMOTE CAPACITY CONTROL CHART	83
WARNINGS/SHUTDOWNS MESSAGES	84
APPENDIX A	97
Quantum™ LX Panel Software Update Procedure	97
APPENDIX B.....	98
OIL SAFETY LOGIC	98
Part 1: Missing Oil Pressure	98
Part 2: Insufficient Main Oil Pressure During Low Differential	98
Part 3: Oil Circuit Pressure Drop	99
Part 4: Oil Pressure Filter Drop	100
OIL PUMP STARTING LOGIC	101
OIL PUMP RUNNING LOGIC.....	102
Demand Pump	102
OIL PUMP STARTING LOGIC	103
Full Time Pump	103
INDEX.....	106

TYPICAL SYSTEM CONFIGURATION

Frick Compressor packages may be used individually, or in groups. This section will describe some of the various configurations that may be used with regard to electrical control.

Each individual Compressor unit is controlled by a computer based machine control system, known as the Quantum™ LX control panel. This controller continuously monitors the conditions and operation of the compressor unit and the various subsystems. It also directs the operation of components. It is fully self-contained.

The Quantum™ LX control panel user interface is used to

display graphic screens, which represent various aspects of compressor operation. By pressing a key on the keypad, the labeled or described function is recognized by the control processor, and appropriate action is taken.

Although the primary means of operator interaction to the compressor package is via the built-in Quantum™ LX control panel, there are two additional methods that emulate the graphic control screens that may be used remotely for compressor control. The following information is presented to help the operator interact with these graphic screens.

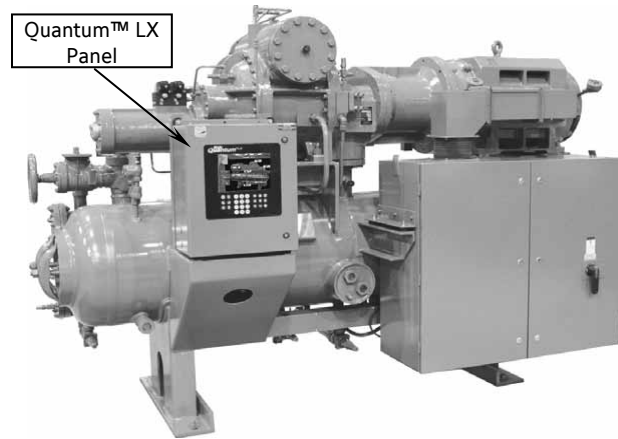

OVERVIEW OF OPERATOR INTERFACES

This section will provide basic overviews of the three possible methods of viewing and accessing the user interface.

QUANTUM™ LX CONTROL PANEL

The Quantum™ LX control panel contains all of the necessary control hardware and software within one self contained enclosure, and is mounted to the compressor package. The front of this control enclosure contains a graphic display and keypad, to allow the operator to access various system essential information and to make necessary adjustments to setpoints, calibrations and features.

Operator access to this system is through various screens. A screen is the physical representation of data on the display. Each screen has a title area. The title is descriptive of the screen. The current date and time is shown in this title area. The day of the week, Sunday (Sun.) through Saturday (Sat.) is displayed. The month of the year from January (Jan.) to December (Dec.) is displayed. The day of the month from 1 to 31 and the year from 0001 to 9999 is displayed. The time displayed is the current time in 24 hours (military) format. The hours, minutes and seconds are displayed.

Some screens are for informational purposes only, and cannot be modified. These screens typically show analog values such as temperature and humidity,

which are strictly functions of an associated sensor, and as such, cannot be modified. Other screens show setpoint values which can be changed, in order modify the units operating characteristics. For easier viewing, related information is separated into boxes. Sometimes selections are hidden when that the feature is unavailable.

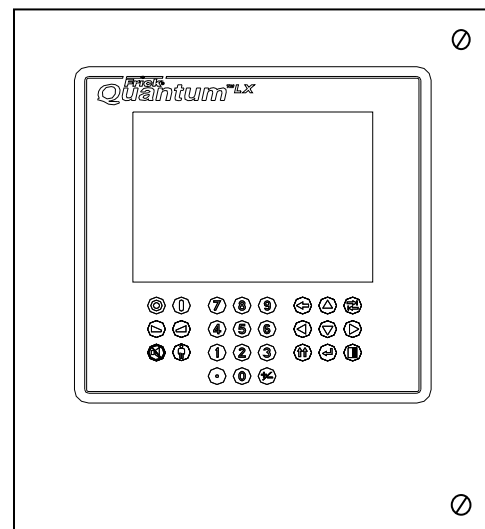

THE QUANTUM™ LX PANEL DISPLAY/KEYPAD

KEYS AND KEY FUNCTIONS

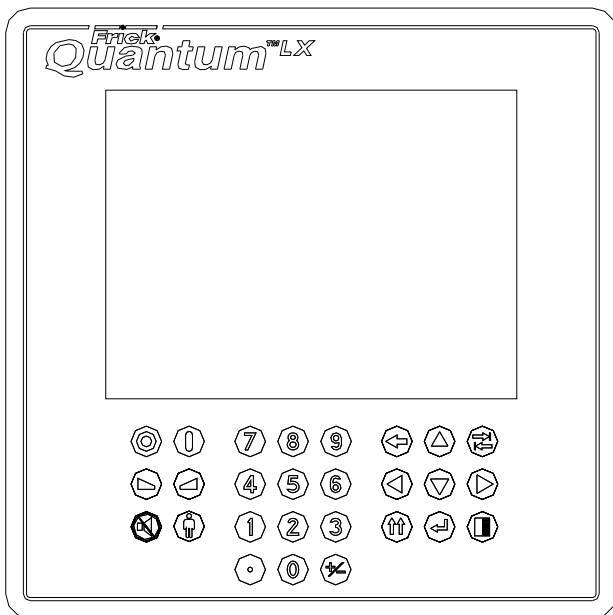

The following is a list of the labeled keypad keys and the actions that occur when they are pressed:

Key	Function
	[STOP] - When the compressor is running in <i>Manual Mode</i> , pressing this key immediately stops the compressor by placing it into Stop Mode. The compressor is stopped regardless of any other conditions.
	[START] - When in Manual Mode, this key places the compressor unit into the Start Mode for running.
	[UNLOAD VALUE] - Unloads Capacity.
	[LOAD VALUE] - Loads Capacity.
	[ALARM SILENCE] - Immediately silences a sounding alarm and turns off the alarm annunciation device that is connected to this panel.
	[MANUAL] - Changes the compressor mode from its current mode to its previous Mode.
	NUMERALS [0] - [9] - The numerical keys are used to enter a value in a data field.

Key	Function
	DECIMAL [.] - This key is used when entering a decimal value in a data field.
	[+/-] - When changing a value in a data field, this key toggles the value between negative and positive.
	[BACKSPACE] - Pressing this key will cause the current location of the cursor to backup one position per key depression. When changing a value in a data field, this key will delete the selected character.
	[UP ARROW] - Provides upward navigation within the <i>MAIN MENU</i> window.
	[TAB] - When in the mode of changing setpoints, pressing this key will cause the cursor to jump to the next data entry field.
	[LEFT ARROW] - When in the mode of changing setpoints, this key is used to go to the previous data entry field. When the <i>MAIN MENU</i> is shown, pressing this key will cancel the window.
	[DOWN ARROW] - Provides downward navigation within the <i>MAIN MENU</i> window.
	[RIGHT ARROW] - When in the mode of changing a data entry field, this key is used to go to the next character.
	[ENTER] - When changing data in a data entry field, this key will accept the change. This key is also used to select items on Menu Windows.
	[SUBMIT] - After changing a setpoint value, Use this key to enter (submit) the change.
	[MENU] - Shows the <i>MAIN MENU</i> window. This window shows the main selections for accessing information, setup of options, and setpoint entry.

WEB BROWSER

The web browser interface can be viewed from any desktop or laptop computer, which has access to the network that the compressor panel is attached to. To change screens, setpoints, etc., you simply use a mouse and the keyboard to view and change data.

All screens that are shown will have a several buttons on the right hand side of the screen. Most screens will have four buttons, and one setpoint box. The three buttons are:

[Menu] – Clicking on this button will cause the main menu to appear on the left side of the screen. Clicking a second time will cause the menu to disappear.

[Start Refresh] [Stop Refresh] – This button(s) appears immediately below the **[Menu]** button. This is actually a toggle button, as it changes function from Start Refresh to Stop Refresh each time it is clicked on. When the button shows as Start Refresh, a setpoint box will appear below it, with a time value displayed. The time value determines how often the display screen will refresh, or update its values. This time value is defaulted to 5 seconds, which means that the display will update all values shown every 5 seconds. Depending on the network connection speed, this updating may interfere with your ability to change data setpoints, because the screen will refresh while you are entering the data. To solve this, simply increase the refresh time. The other alternative is to toggle the Refresh Button. By pressing **[Stop Refresh]**, screen refreshing will terminate, and the time setpoint box will reappear. In this state, the particular screen that you

are viewing will never update the displayed values. Changing to another screen will show the most recent values on the new screen, and then will not update again. So in the Stop Refresh state, screens will only be updated when new screens are accessed. This feature should not be used when monitoring for data. Try to find an acceptable refresh time for the Start Refresh state.

[Submit] – After having made changes to any information, the **[Submit]** button must be pressed for the controller to accept the new changes. This button performs the same function as the physical **[Submit]** button on the panel keypad.

NOTE: One screen that DOES NOT show any of these buttons is:

Software Maintenance – To leave this screen, click on the **[Exit]** button. **Note:** Using the **[Exit]** button takes several seconds, and it will force the password level back to zero.

[Help] – This button will appear on all screens with the exception of the *Documentation* screen. When pressed, the appropriate page(s) of the Operators Manual will be shown to help describe the functions of the applicable screen.

There are numerous screens that have additional buttons to those mentioned here. These additional buttons are self-intuitive, and as such, are not discussed here.

CHANGING SETPOINTS

The setpoints define the operation and limits of the compressor. These setpoints can be changed by operators in the field. These setpoints are stored on the compact Flash card.

NOTE: Setpoints are not lost after power is interrupted. However, we suggest that a list of Setpoints be recorded and stored safely to facilitate reentry, in case there is a need to return to the original settings.

1. The data entry fields are identified by a black box with a white interior. The data is shown in black text. When on a screen that has adjustable setpoints, tab to the setpoint box that you wish to modify (or select it on a web browser). Once the data field has been selected, the background turns blue, and the text turns white.
2. The current value of that setpoint is shown. Use the keypad to enter the new value. Typing a new value will completely erase the old value.
3. Press the keypad **[ENTER]** key to input the new data in the data entry field and to move to the next data entry field.
4. Once all entries/changes have been made, pressing the **[SUBMIT]** button will save the setpoint changes to memory.
5. If the value is out of bounds, an error message box displays the proper range of values. Press the **[OK]** button to acknowledge the error message. Re-enter a correct value.

MENU STRUCTURE

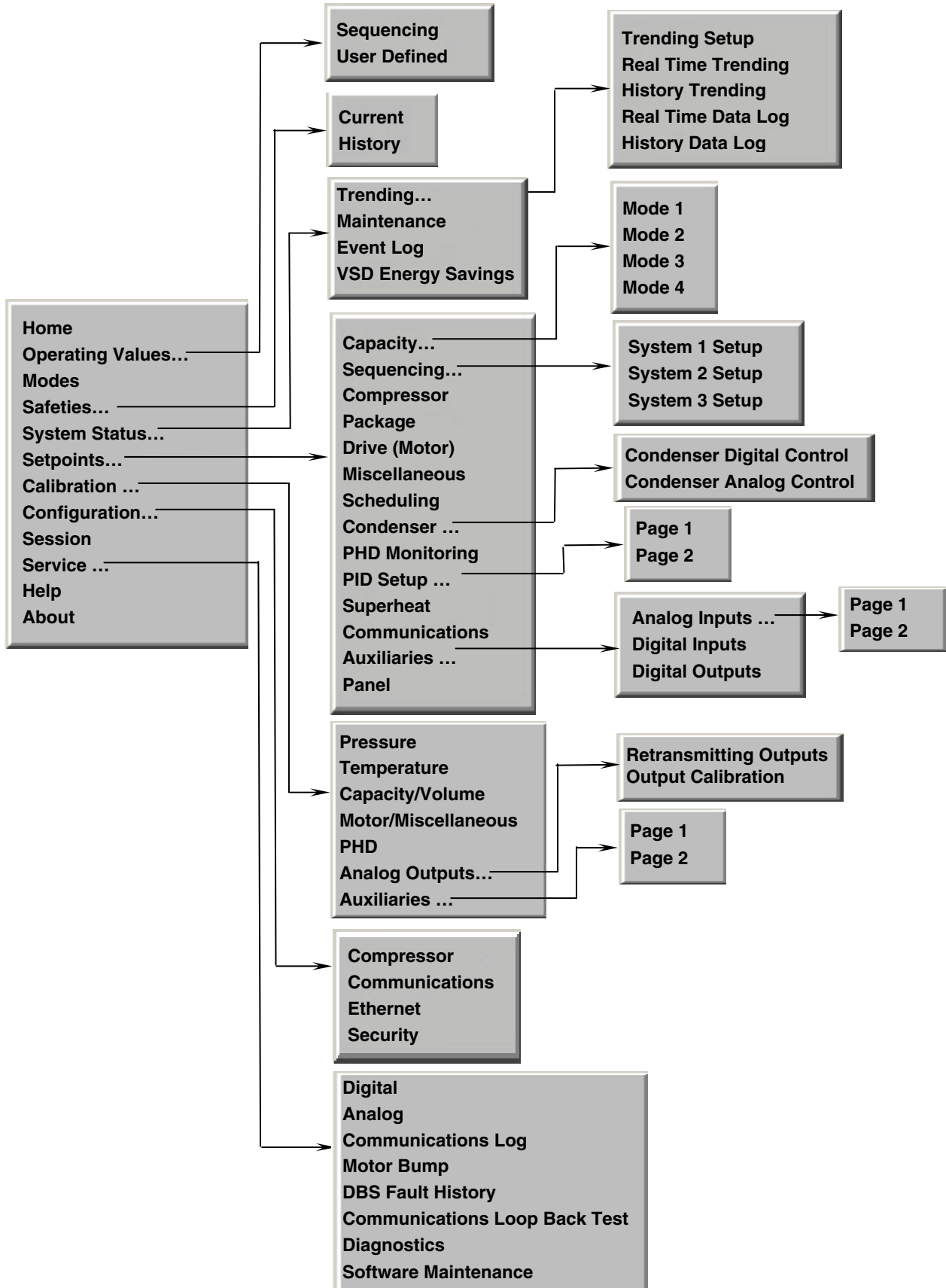

The above graphic represents the menu structure, or tree, of the Quantum™ LX screens. Use this tree when accessing the various screens. Please note that this

screen list is complete, and that certain screens may not be available as shown here, depending upon the enabled options.

OPERATING DISPLAY SCREENS

Operating Status (Home)

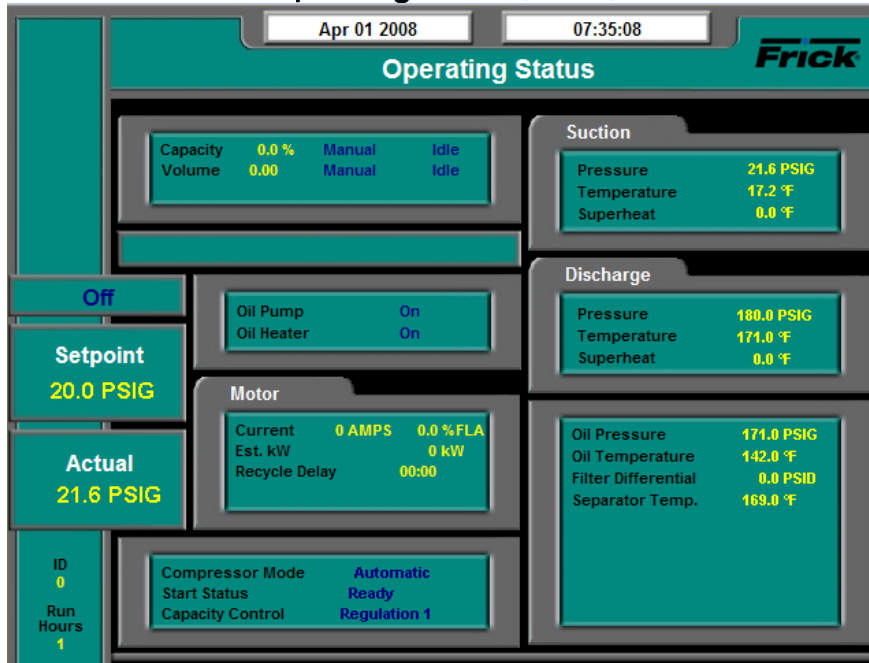

ACCESSING:



Home

DESCRIPTION: This is the default screen. When power is applied, this screen will appear. Also called the *Home* screen. The most important information about the compressor and the applicable subsystems operation is displayed here. This screen is shown when power is first turned on and when a key is pressed after the screen saver has turned off the backlight. The *Operating Status* screen is continuously updated and provides a variety of information with regard to the current condition and performance of the compressor unit and subsystem.

The following information is shown on this screen:

DATE - The actual date will be displayed in this box. The date must first be set correctly on the *Configuration* screen. Once set, the date will be automatically adjusted for at the end of each month, much like the calendar feature of most modern watches. The primary use of the date feature is to provide a date stamp for Warnings and Shutdowns. (See also *TIME*)

TIME - The actual time will be displayed in this box. The time must first be set correctly on the *Configuration* screen. The time will also need to be adjusted for those locations which observe Daylight Savings Time. The primary use of the time feature is to provide a time stamp for Warnings and Shutdowns. (See also *Date*)

SCREEN TITLE - This is the title for the screen that is showing. Each screen will have a title. The Quantum™ LX manuals will extensively refer to screens by these names. When referred to in these manuals, screen names will be shown in bold italic print, such as *Operating Status*.

COMPRESSOR MODEL - This is actually a rotating marquee. It will alternately display the model name of the compressor (such as RWF) and will then rotate to show Frick®.

COMPRESSOR RUN STATUS -

- Off
- Running
- Starting
- Stopping
- Stopping - High Capacity
- Stopping - Pumpdown

PROCESS SETPOINT VALUE - This is the control setpoint maintained by the internal capacity control.

PROCESS ACTUAL VALUE - The actual reading of the pressure or temperature that was chosen as the compressor control setpoint.

ID - The value shown here is the number that has been assigned to this particular unit on the *Communications Setup* screen.

RUN HOURS – The value shown here is the total number of hours that the compressor has been actually running, during its lifetime.

CAPACITY/VOLUME CONTROL BOX - Shows what is presently controlling the Slide Valve and from what source it was initiated. The following sources may be shown:

Capacity:

- Manual
- Automatic
- Remote -- Communications
- Remote -- IO
- Remote -- 4-20 Input
- Remote -- Sequencing

VOLUME:

- Manual
- Automatic

RUN HOURS – The total amount of time in hours that the compressor motor has run.

WARNING/SHUTDOWNS STATUS BOX - The Warning/Shutdowns Status is displayed below the Capacity/Volume status box. This status box is blank with no message if there are no warnings or shutdowns present.

If a Warning or Shutdown occurs, a flashing message will be shown, identifying the type of warning or shutdown. As an example, if the Oil Temperature has been less than or equal to the *Low Oil Temperature Warning* setpoint for its time delay setting, then a **Low Oil Temperature Warning** will be shown. If the *warning is not cleared by the operator, and the Oil Temperature continues to drop to a point that is less than or equal to the Low Oil Temperature Shutdown setpoint for its time delay setting, then a Low Oil Temperature Shutdown* is issued, and the compressor, if running, will stop. The definitions for the two types of messages are as follows:

WARNING - A specific warning message flashes when a warning is present. A warning is a condition that requires operator acknowledgement but allows the compressor to continue to run if it is already running.

A Warning message indicates that a warning setpoint has been reached, or exceeded.

SHUTDOWN - This specific shutdown message flashes when a shutdown is present. A shutdown is a condition that requires an operator to acknowledge, and causes the compressor to shut down.

A Shutdown message indicates that a shutdown setpoint has been reached, or exceeded.

When a Shutdown occurs, the display backlight will flash on and off to alert an operator of the shutdown. This visual alarm will help get the attention of the operator in a noisy engine room environment where audible alarms may not be heard. Pressing any key on the keypad will clear the flashing backlight.

OIL LUBRICATION DEVICE STATUS BOX - The operating status is shown for the following devices:

Oil Pump - (If selected in the *Configuration*) - The *On* or *Off* message is shown for the status of the oil pump. The Manual or Auto message is shown to indicate the position of the HAND-OFF-AUTO switch. If dual pump control was enabled in *Configuration*, the lead pump (either Oil Pump 1 or Oil Pump 2) is shown.

Oil Heater - The On or Off message is shown for the status of the oil separator heater(s).

MOTOR STATUS BOX - The following items are shown:

Motor Amps - The actual motor amps.

%FLA - The percentage of the drive motor full load amperage rating that the motor is currently using: % (FLA x SF)

Kilowatts - The actual calculation of the kilowatt usage of the compressor motor. It is based on the calculation of $KW = (\sqrt{3} \times V \times A \times PF) / 1000$.

Recycle Delay - This message shows the remaining time in minutes for Recycle Delay. If the compressor has started and shuts down within the recycle time delay setpoint period, the Recycle Delay will prevent the compressor from starting until the delay time expires. This time delay is intended to prevent damage to the compressor motor from successive restarts.

Note: The remaining recycle delay time can be cleared from the **Motor** screen

COMPRESSOR STATUS BOX - Shows the present operating status of the compressor and from what source it has been initiated:

Compressor Mode - One of the following messages is shown:

- **Manual** - A compressor manual start or stop command was sent.

- **Automatic** - The compressor auto command was sent. The compressor starting and stopping is being controlled from automatic cycling control setpoints at the panel. The automatic cycling control setpoints of the active capacity control are used.
- **Remote -- Communications** - The compressor remote communications command was sent. The compressor starting and stopping is through the serial Com-2 channel.
- **Remote -- IO** - The compressor remote I/O command was sent.
- **Remote -- Sequencing** - The compressor remote sequencing command was sent.

Note: If there is a shutdown in response to a safety setting, a compressor in *Remote* or *Automatic* mode is placed into *Manual* mode requiring operator intervention.

Start Status - One of the following messages is shown:

- Ready
- Start Inhibit In Shutdown
- Start Inhibit In Recycle Delay
- Start Inhibit High Discharge Temp.
- Start Inhibit High Oil Temperature
- Start Inhibit Low Separator Temperature
- Start Inhibit Slide Valve Too High
- Start Inhibit Still In Prelube
- Start Inhibit High Suction Pressure
- Start Inhibit High Suction/Discharge Differential
- Start Inhibit Permissive Start
- Start Inhibit Digital Auxiliaries
- Power Fail Restart

Capacity Control - One of the following messages is shown:

- Mode 1
- Mode 2
- Mode 3
- Mode 4

SUCTION PRESSURE & TEMPERATURE BOX - The following sensor information is displayed:

Suction Pressure - Is measured at the compressor inlet and the value is displayed along with the unit of measure.

Suction Temperature - Is measured at the compressor inlet and the value is displayed along with the unit of measure.

Superheat - The temperature of the gas at saturation temperature for a given period of time.

DISCHARGE PRESSURE & TEMPERATURE BOX - The following sensor information is displayed:

Discharge Pressure - Is measured at the compressor outlet and the value is displayed along with the unit of measure.

Discharge Temperature - Is measured at the compressor outlet and the value is displayed along with the unit of measure.

Superheat - Superheat is the term used to describe the difference between the *vapor point* (i.e., the temperature at which the refrigerant evaporates at a given pressure) and the actual temperature of the refrigerant exiting the evaporator coil.

OTHER PRESSURES AND TEMPERATURE BOX - The following sensor information is displayed:

Oil Pressure - Is measured prior to entering the compressor and the value is displayed along with the unit of measure.

Oil Temperature - Is measured prior to entering the compressor and the value is displayed along with the unit of measure.

Filter Differential - If applicable, pressure drop across the oil filter. The main oil injection oil filter pressure drop value (differential) is displayed along with the unit of measure.

Separator Temperature - The Oil Separator Temperature value is displayed along with the unit of measure.

Process Temperature - If applicable, the Leaving Process Temperature value is displayed along with the unit of measure.

Balance Piston - If applicable, the Balance Piston pressure reading is displayed along with the unit of measure. This reading is a measurement of the presence at the Balance Piston.

OPERATING VALUES - Sequencing

Frick		Apr 04 2008	13:48:02	Stopping	
Sequencing - Status			ID 194	Setpoint 20.0 PSIG	Actual 39.2 PSIG
System 1			System 0		
Sequencing Is Enabled			Setpoint 32.0 °F	Control Point 32.0 °F	
Sequencing ID	Start #	% Capacity	Type	Run Time Hours	Status
1	1	0.0	RWFII	0	MManual
2	2	0.0	RWFII	0	MManual
3	3	0.0	RWFII	0	MManual
4	4	0.0	RWFII	0	MManual
5					
6					
7					
8					

System 2			Setpoint 32.0 °F	Control Point 32.0 °F	
Sequencing Is Disabled					
Sequencing ID	Start #	% Capacity	Type	Run Time Hours	Status
1					
2					
3					
4					
5					
6					
7					
8					

System 3			Setpoint 32.0 °F	Control Point 32.0 °F	
Sequencing Is Disabled					
Sequencing ID	Start #	% Capacity	Type	Run Time Hours	Status
1					
2					
3					
4					
5					
6					
7					
8					

ACCESSING:  → **Operating Values...** → **Sequencing**

DESCRIPTION: This screen will be available if Sequencing is enabled in *Compressor* configuration. This is strictly a status screen, no values can be changed from here.

The following is a description of the Sequencing strategy:

Start/Stop

System Setup:

- Control Input – Suction Pressure
- Control Direction – Forward
- High Stage Link – Disabled

Start Procedure

Before starting a compressor, the master must determine that all the running compressors are loaded and that the *Suction Pressure* has risen to a point where an additional compressor is needed.

First, the master checks that either no compressors are running or all the running compressors average 90% capacity. If a running compressor is at less than 90% capacity but is in a Load Inhibit or Force Unload condition, for the purposes of this calculation it is assumed to be at 90% capacity.

If all the running compressors are loaded the master next begins comparing its *Suction Pressure* to the Autocycle Start setpoint. When the Suction Pressure rises above the Start setpoint, the start timer is initiated. If the start timer reaches the Autocycle Start Delay setpoint time and the Suction Pressure has remained above the Start setpoint for the entire time,

the master attempts to start an additional compressor. If the Autocycle Start Delay setpoint is 0 minutes, the master still waits 15 seconds before starting a compressor.

To determine which compressor to start, the master first sorts all the compressors in the system based on their start number, low to high. If two compressors have the same start number, the first one on the list remains ahead of the second. Next, the master starts at the top of the list and works down through list until it finds a compressor that is available to run. To be deemed available, a compressor must have good sequencing communications and its Compressor Mode and Capacity Mode must be set as Remote Sequencing. In addition the compressor must be off, and it cannot be in a Start Inhibit condition except for the Start Inhibit Slide Value Too High condition. The compressor with the lowest start number that also meets these conditions is then sent a start command. If no compressors are currently available to start, the master will continue checking until one becomes available or until the Suction Pressure drops below the Start setpoint.

After a compressor has been sent a start command, the master waits for that compressor to reach a Running state. If 3 minutes passes and the compressor has not yet begun to run, the master sends it a stop command. This compressor is then flagged as Unable to Start for 1 hour. After that time

the master may again try to restart the compressor if additional capacity is needed. After a compressor begins running or after one fails to start and is sent a stop command, the master can begin the process of starting another compressor.

Stop Procedure

If the *Suction Pressure* drops to a point where one of the running compressors is no longer needed, the master will stop the last compressor in the sequence list.

When the *Suction Pressure* drops below the Autocycle Stop setpoint, the stop timer is initiated. If the stop timer reaches the Autocycle Stop Delay setpoint time and the *Suction Pressure* has remained below the Stop setpoint for the entire time, the master attempts to stop one of the running compressors. If the Autocycle Stop Delay setpoint is 0 minutes, the master still waits 15 seconds before stopping a compressor.

To select the compressor to stop, the master also sorts all the compressors in the system according to their start number. Then the master starts at the bottom of the list and works up, looking for a running compressor that can be stopped. To be selected a compressor must have good sequencing communications and its Compressor Mode and Capacity Mode must be set as Remote Sequencing. In addition, the compressor's run time must be greater than the compressor's Minimum Run Time setpoint. If the Minimum Run Time setpoint is 0 minutes, a compressor can also be stopped if it is still in Starting mode. The compressor with the highest start number that meets these conditions is sent a stop command. If no compressors are currently available to stop, the master will continue checking until one becomes available or until the *Suction Pressure* rises above the Stop setpoint.

After a compressor has been sent a stop command, the master waits for that compressor to go to off. If 3 minutes passes and the compressor has not yet turned off, the master then flags this compressor as Unable to Stop for 1 hour. After that time the master may again try to stop the compressor. After a compressor goes to off or after one fails to stop within 3 minutes, the master can begin the process of stopping another compressor.

Load/Unload

System Setup:

- Control Input – Suction Pressure
- Control Direction – Forward
- High Stage Link – Disabled

Load Procedure

If the master compressor's Suction Pressure is above the Capacity Control setpoint, the master calculates the increase in capacity that is required. The calculation is as follows:

$$\text{Difference} = \text{Suction Pressure} - (\text{Capacity Control Setpoint} + \text{Upper Dead Band})$$

If the Difference is less than the Upper Proportional Band:

$$\text{Capacity Change} = (\text{Difference} / \text{Upper Proportional Band}) * \text{Upper Cycle Time}$$

If the Difference is greater than the Upper Proportional Band:

$$\text{Capacity Change} = \text{Upper Cycle Time}$$

After the capacity increase has been calculated, the master then finds the compressor whose capacity should be changed. To make this determination, the master sorts all the compressors based on their start number. Beginning at the compressor with the lowest start number, the master finds the first compressor on the list that is running but is not at its maximum capacity. A compressor is at maximum capacity if it is at 100 percent capacity or if it is in a Load Inhibit or Force Unload condition.

If the selected compressor is running the Quantum LX software, the capacity increase is added to the compressor's current capacity. This new value is then sent to the compressor as its Capacity Command, and that compressor will try to increase its capacity to match the Command value.

If the selected compressor is controlled by a Quantum 1-4 or a Plus panel, the capacity increase is interpreted as the time period for a load pulse and is sent to the compressor as a load command. The slave compressor will then turn on its load output for the given number of seconds.

Unload Procedure

If the master compressor's *Suction Pressure* is below the Capacity Control setpoint, the master calculates the decrease in capacity that is required. The calculation is as follows:

$$\text{Difference} = (\text{Capacity Control Setpoint} - \text{Upper Dead Band}) - \text{Suction Pressure}$$

If the Difference is less than the Lower Proportional Band:

$$\text{Capacity Change} = (\text{Difference} / \text{Lower Proportional Band}) * \text{Lower Cycle Time}$$

If the Difference is greater than the Lower Proportional Band:

$$\text{Capacity Change} = \text{Lower Cycle Time}$$

After the capacity decrease has been calculated, the master then finds the compressor whose capacity should be changed. To make this determination, the master sorts all the compressors based on their start number. Beginning at the compressor with the highest start number, the master finds the last compressor on the list that is running and whose capacity is above its Minimum Capacity setpoint. If two compressors are currently running at or below their Minimum Capacity setpoints, the master will not allow any additional compressors to unload. This will allow the Suction Pressure to continue to drop and will cause the master to turn off one of the unloaded compressors. If the master sees that only one compressor is running in its system, it will continue to unload the compressor down to the master's Automatic Capacity Mode Minimum Slide Valve Position setpoint.

If the selected compressor is running the Quantum LX software, the capacity decrease is subtracted from the compressor's current capacity. This new value is then sent to the compressor as its Capacity Command, and that compressor will try to decrease its capacity to match the Command value.

If the selected compressor is controlled by a Quantum 1-4 or a Plus panel, the capacity decrease is interpreted as the time-period for an unload pulse and is sent to the compressor as an unload command. The slave compressor will then turn on its unload output for the given number of seconds.

High Stage/Booster

The High Stage System Link setpoint is provided to tie a system of Booster compressors to a system of High Stage compressors. For example, if the Booster compressors are setup on System #1 and the High Stage Compressors are on System #2, the High Stage System Link setpoint from System #1 would be set as *System 2*.

When the Booster System's master wants to start the first Booster compressor, it first checks that a Booster compressor is available to run and then sends a signal to the High Stage System's master telling it to start a High Stage compressor. If all the High Stage compressors are off, the High Stage System's master will start its first compressor, regardless of what the High Stage Control Input is reading. When the Booster System's master observes that a High Stage compressor is running, it will allow a Booster compressor to start.

After the first High Stage compressor begins to run, compressors in both systems will cycle on and off as

their Control Inputs move up and down. The only stipulation to the control strategy is that one High Stage compressor must always remain on as long as at least one Booster compressor is running. If all the Booster compressors turn off, the High Stage compressor can then turn off as well.

Establish Sequencing Communications Using An Ethernet Connection

Perform the following steps on each panel that will be part of the sequencing group:

- From the Main Menu, select **[Session]**.
- At the Session menu, set the User Level to **[2]**, and enter a password of **[20]**, then press **[Submit]**. This will set the user access to level 2, which is the minimum level needed to access the sequencing feature.
- Next press **[Menu] > [Configuration]** and select **[Compressor]**.
- On the Compressor Configuration screen, tab down to enable **[Sequencing]**, then tab over to **[Mode 3]** and enable it. Press **[Submit]**.
- Once again select **[Menu] > [Setpoints] > [Sequencing]** then **[System 1 Setup]**.
- On the **[System 1 Setup]** screen, tab to Sequencing and **[Enable]** it. Next set the Control Setpoint to the value that you wish to control to. Set the Minimum Runtime to **[10 Min]**, and set High Stage System Link as **[None]**.
- Now set Sequencing ID #1 as **[last octet of 1st Compressor's IP address]**, set the Start # as **[1]**, Compressor and Capacity Modes as **[Remote Seq.]** and Minimum Capacity as proper value.
- Next set Sequencing ID #2 as **[last octet of 2nd Compressor's IP address]**, set the Start # as **[2]**, Compressor and Capacity Mode as **[Remote Seq.]** and Minimum Capacity as proper value.
- Go to **[Menu] > [Modes]**. Verify that the Active Mode is set to either Mode 3 or Mode 4.
- Finally, go to the **[Menu] > [Operating Values] > [Sequencing]**. Ensure that a status other than not communicating is present for both machines.

This concludes the Sequencing setup.

OPERATING VALUES - *User Defined Operating Status*

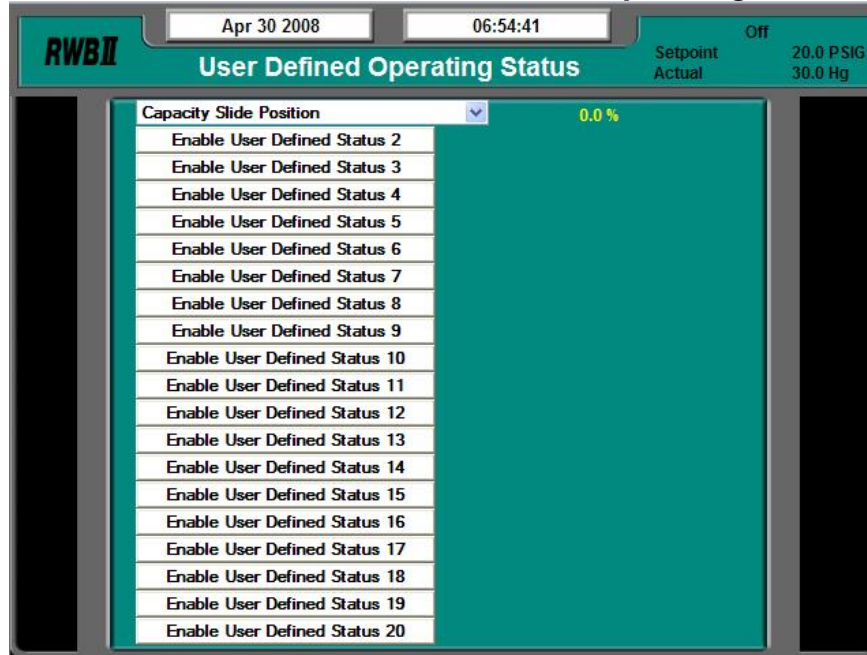

ACCESSING:



Operating Values...

User Defined

DESCRIPTION: The purpose of this screen is to allow the user to assign additional analog channels to be more readily viewable. Since the main *Operating Status* (Home) screen is capable of only showing a limited number of pre-assigned analog values, it may be desirable for the user to have a method of viewing additional information that they can select, on a common screen. They may even select values that are already being displayed on the *Operating Status* screen, as well as values that are not shown there.

This screen is provided to allow the user to view up to 20 different analog channels of their choosing.

As an example of how this screen works, assume that in addition to the data that is shown on the *Operating Status* screen, the user would like to monitor the *Capacity Slide Position*, *Auxiliary Analog Channel 1* and *Compressor Vibration -Suction*, all on the same screen (this one). Notice that *Capacity Slide Position* is already shown on the *Operating Status* screen, but the user would also like to see *Auxiliary Analog Channel 1* and *Compressor Vibration -Suction* on the same screen. In order to set this screen up this way, the user would highlight the Enable User Defined Channel 1 (or whatever channel they wish to use), by pressing the [Tab] key. Once the box is highlighted, use the [Enter] key to cause the possible settings for the channel to appear. Use the arrow keys to scroll through the list. When the selection that you want to use has been highlighted, press the [Enter] key to select it. Once selected, a value will appear to the right of the list, which corresponds to the analog value for that channel.

The following selections may be shown on this screen:

- Capacity Slide Position
- Volume Slide Position
- Suction Pressure
- Discharge Pressure
- Compressor Oil Pressure
- Main Oil Injection Pressure
- Economizer Pressure
- Filter Pressure
- Intermediate Pressure
- Balance Piston Pressure
- System Discharge Pressure
- Suction Temperature
- Discharge Temperature
- Compressor Oil Temperature
- Oil Separator Temperature
- Process/Brine Temperature Leaving
- Process/Brine Temperature Entering
- Motor Current
- RPM
- User defined analog inputs #1 - #10
- EZ Cool Feedback %
- User defined analog inputs #12 - #20
- Manifold Pressure
- Compressor Vibration - Suction
- Compressor Vibration - Discharge
- Motor Vibration - Shaft Side
- Motor Vibration - Opposite Shaft Side
- Motor Temperature - Shaft Side
- Motor Temperature - Opposite Shaft Side
- Motor Stator #1
- Motor Stator #2
- Motor Stator #3

OPERATING VALUES – VYPER – *Vyper*

Dec 09 2008 09:30:47

Frick Vyper Setpoint Off 20.0 PSIG Actual 30.0 Hg

Average Current	0 AMPS	Actual Speed	0 RPM
Current Phase A	0 AMPS	Speed Command	0 RPM
Current Phase B	0 AMPS	Ambient Temperature	-0.0 °F
Current Phase C	0 AMPS	Converter Heatsink Temperature	-0.0 °F
Full Load Amps	0.0 %	Phase A Baseplate Temperature	-0.0 °F
Output Frequency	0.00 Hz	Phase B Baseplate Temperature	-0.0 °F
Output Voltage	0 V	Phase C Baseplate Temperature	-0.0 °F
DC Bus Voltage	0 V	VSD Operating Mode	Off
Input Power	0 kW	Harmonic Filter Present	No
Command Rate	6 / Sec	Harmonic Filter Operating Mode	Off
Standby Time	20 MIN	Water Pump Energized	Off
Current Value	00:00	Precharge Relay Energized	Off
		Trigger SCRs Energized	Off
		Job FLA	0 AMPS
		DC Inverter Link Current	0 AMPS
		Motor Temperature	-0.0 °F
		VSD Model	0 Hp
		Total kWh	0 kWh

Clear Standby Time Clear VSD Fault Memory Clear Total kWh

ACCESSING:



Operating Values...

Vyper...

Vyper

DESCRIPTION: This screen only appears if a Vyper drive is installed. The screen is used to view and change specific operating values having to do with the Vyper drive.

OPERATING VALUES – VYPER – *Harmonic Filter*

Dec 09 2008 09:32:39

Frick Harmonic Filter Setpoint Off 20.0 PSIG Actual 30.0 Hg

	Leg 1	Leg 2	Leg 3
Total Harmonic Distortion	0.0 %	0.0 %	0.0 %
Total Demand Distortion	0.0 %	0.0 %	0.0 %
Filter Current	0 AMPS	0 AMPS	0 AMPS
Supply Current	0 AMPS	0 AMPS	0 AMPS
L1-N Voltage	0 V	Auto/Manual Switch Status	0
L2-N Voltage	0 V	Manual Speed Switch Status	0 RPM
L3-N Voltage	0 V	Line Frequency Jumper Status	60 Hz
L1-L2 Voltage	0 V	Run Command Signal Status	Stop
L2-L3 Voltage	0 V	No Faults Signal Status	Fault
L3-L1 Voltage	0 V	Run Acknowledge Relay Status	Stopped
		Run Command Relay Status	Stop
Total Supply KVA	0 KVA	Interface Board Version	0
Total Power Factor	0.00 %	VSD Version	0
Baseplate Temperature	-0.0 °F	Modbus Node ID	0
DC Bus Voltage	0 V	IB Transmit Errors	0
Supply Contactor Energized	Off	CP To IB Timeout Errors	0
Precharge Contactor Energized	Off	VD To IB Timeout Errors	0
Phase Rotation Direction	ABC	IB To VD Receive Errors	0
		VD To IB Checksum Errors	0
		HF To IB Timeout Errors	0
		VD To HF Receive Errors	0
		HF To IB Checksum Errors	0
		Software Reboots	0

ACCESSING:



Operating Values...

Vyper...

Harmonic Filter

DESCRIPTION: This screen only appears if a Vyper drive is installed. The screen is used to view specific operating values having to do with the Harmonic Filter of the Vyper drive.

MODES

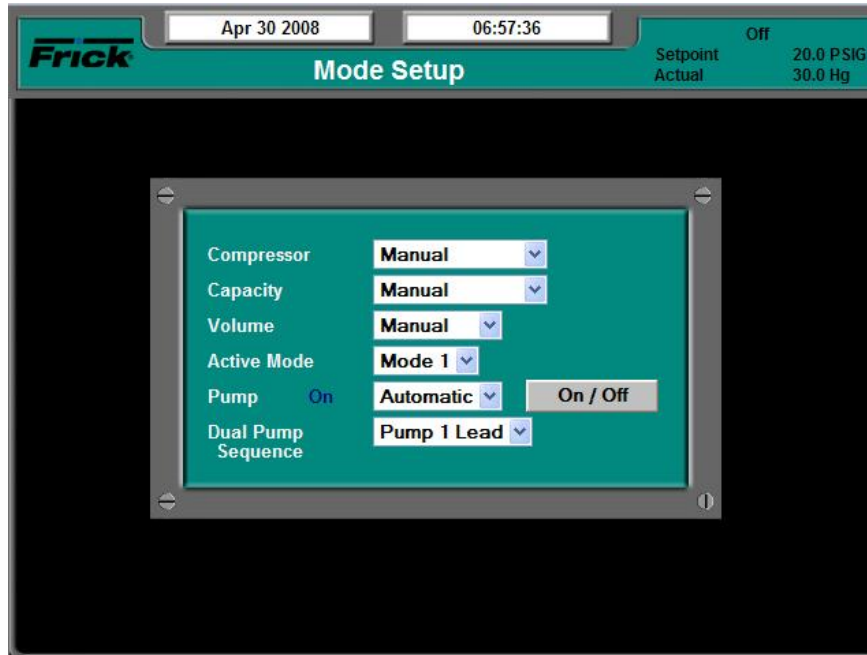

ACCESSING:



Modes

DESCRIPTION: The purpose of this screen is to allow the user to assign operational states (such as manual or automatic) to the various modes shown on the screen.

The following pull-down menus are shown here:

Compressor:

- Manual
- Automatic
- Remote -- Communications
- Remote -- IO
- Remote -- Sequencing

Capacity:

- Manual
- Automatic
- Remote -- Communications
- Remote -- IO
- Remote -- 4-20 Input
- Remote -- Sequencing

Volume:

- Manual
- Automatic

Active Mode:

- Mode 1
- Mode 2
- Mode 3
- Mode 4

Pump (if enabled):

A Pump On/Off indicator (blue text) is provided here to alert the user as to the actual status of the Oil Pump (if applicable). A drop down menu is also provided, and there are two states that can be selected for oil pump operation, they are:

Manual - The user has control over the running of the pump. To run the pump, simply observe the blue text indicator to ensure that the pump is not already running, and if not, then press the **[On/Off]** toggle button. The blue text indicator will change from *Off* to *On*. To stop the pump, press the toggle button again, and the pump indicator will change to *Off*.

Automatic - If the pump is set to Automatic mode, the Quantum™ LX software program is controlling the pump operation. In this mode, if the toggle key is pressed, the mode will be changed from Automatic to Manual Mode, and the current state of the pump (digital output 3) will toggle also.

Dual Pump Sequence (if enabled):

- Pump 1 Lead
- Pump 2 Lead

SAFETIES - History - Current Safeties

Safety	Occurred
01 DBS Communication Failure Shutdown	04-22-08 14:40:49
02 Low Filter Pressure Sensor Warning	04-22-08 14:40:49
03 Low Separator Temperature Sensor Fault	04-22-08 14:40:49
04 Low Comp. Oil Temperature Sensor Fault	04-22-08 14:40:49
05 Low Discharge Temperature Sensor Fault	04-22-08 14:40:49
06 Low Comp. Oil Pressure Sensor Fault	04-22-08 14:40:49
07 Low Discharge Pressure Sensor Fault	04-22-08 14:40:49
08 Low Suction Pressure Sensor Fault	04-22-08 14:40:49

ACCESSING:



Safeties...

Current

DESCRIPTION: The *Current Safeties* screen shows the Warnings and Shutdowns that have recently occurred (up to 50). When a warning or shutdown is triggered, a blue descriptive message shows on this screen. The date and time of the warning or shutdown occurrence is shown to the right of its description. The most recent message will appear on the top line of the screen with the oldest appearing at the bottom. When a Warning or Shutdown is logged to this screen, it will also be logged to the *Safety History* screen.

The following *Current Safeties* screen key is provided:

[Clear Safeties] - Selecting this key will clear all warnings and/or shutdowns from this screen. This will also place a date/time stamp for the corresponding entry on the *Safety History* screen showing that the particular Warning or Shutdown was cleared. Clearing the entry on the *Current Safeties* screen, will not clear it from the *Safety History* screen.

To resume normal operation it will be necessary to go through the following steps:

1. Correct the condition(s) causing the warning.
2. Press the **[ALARM SILENCE]** key. (This action may precede correcting the condition(s) causing the warning). Or, go to step 3.
3. To clear or reset the *Warnings/Shutdowns* screen and turn off any warning annunciation device, from the screen, press the **[Clear Safeties]** key. This will also clear the WARNING or SHUTDOWN message from the *Operating Status* screen.

4. If the conditions causing the warning have not been corrected or a new fault has occurred, a new *WARNING* or *SHUTDOWN* message will appear. The *Safety History* screen keeps a record of the warnings and shutdowns. This information will help troubleshoot persistent operational problems.

Refer to the *Warnings/Shutdowns Message* section for a list of all the possible conditions.

When a Shutdown occurs, the screen backlight will flash on and off to alert an operator of the shutdown. This visual indication will help get the attention of the operator in a noisy engine room environment where audible alarms may not be heard. Pressing any key on the keypad will clear the flashing backlight.

SAFETIES - History - Safety History



Safety	Occurred	Cleared
01 DBS Communication Failure Shutdown	04-22-08 14:40:49	
02 Low Filter Pressure Sensor Warning	04-22-08 14:40:49	
03 Low Separator Temperature Sensor Fault	04-22-08 14:40:49	
04 Low Comp. Oil Temperature Sensor Fault	04-22-08 14:40:49	
05 Low Discharge Temperature Sensor Fault	04-22-08 14:40:49	
06 Low Comp. Oil Pressure Sensor Fault	04-22-08 14:40:49	
07 Low Discharge Pressure Sensor Fault	04-22-08 14:40:49	
08 Low Suction Pressure Sensor Fault	04-22-08 14:40:49	
09 DBS Communication Failure Shutdown	04-22-08 04:37:55	04-22-08 14:40:29
10 Low Filter Pressure Sensor Warning	04-22-08 04:37:55	04-22-08 14:40:29
11 Low Separator Temperature Sensor Fault	04-22-08 04:37:55	04-22-08 14:40:29
12 Low Comp. Oil Temperature Sensor Fault	04-22-08 04:37:55	04-22-08 14:40:29
13 Low Discharge Temperature Sensor Fault	04-22-08 04:37:55	04-22-08 14:40:29
14 Low Comp. Oil Pressure Sensor Fault	04-22-08 04:37:55	04-22-08 14:40:29
15 Low Discharge Pressure Sensor Fault	04-22-08 04:37:55	04-22-08 14:40:29
16 Low Suction Pressure Sensor Fault	04-22-08 04:37:55	04-22-08 14:40:29
17 DBS Communication Failure Shutdown	04-20-08 16:22:18	04-22-08 04:37:35
18 Low Filter Pressure Sensor Warning	04-20-08 16:22:18	04-22-08 04:37:35
19 Low Separator Temperature Sensor Fault	04-20-08 16:22:18	04-22-08 04:37:35
20 Low Comp. Oil Temperature Sensor Fault	04-20-08 16:22:18	04-22-08 04:37:35
21 Low Discharge Temperature Sensor Fault	04-20-08 16:22:18	04-22-08 04:37:35
22 Low Comp. Oil Pressure Sensor Fault	04-20-08 16:22:18	04-22-08 04:37:35
23 Low Discharge Pressure Sensor Fault	04-20-08 16:22:18	04-22-08 04:37:35
24 Low Suction Pressure Sensor Fault	04-20-08 16:22:18	04-22-08 04:37:35

ACCESSING:



Safeties...

History

DESCRIPTION: The *Safety History* screen shows the warnings and shutdowns that have recently occurred (up to 50 maximum). When a warning or shutdown is triggered, a blue descriptive message shows on this screen. The date and time of the warning or shutdown occurrence is shown to the right of its description, followed by the date and time that the safety was cleared (if applicable, from the *Current Safeties* screen). The most recent message will appear on the top line of the screen with the oldest appearing at the bottom.

It is possible to view the conditions that existed on the *Operating Status* screen at the exact moment that a condition occurred. Use the arrow keys of the keypad to select (highlight) a warning or shutdown and then press the [Enter] key to view its associated *Freeze (Operating Status)* screen.

Freeze Screen Description

This *Freeze* screen provides a snapshot of the values that were current at the time of the latest shutdown. The information on the *Freeze* screen can help the user to identify the cause of a fault, which occurred when no one was present. The *Freeze* screen freezes

the information of the *Operating Status* screen AT THE MOMENT OF A COMPRESSOR WARNING OR SHUTDOWN. The Freeze screen has the same appearance and contains the same information as the *Operating Status* screen. (For a description of the information presented by the *Freeze* screen, refer to the *Operating Status* screen). The *Freeze* screen will retain the information generated by a warning or shutdown. The last fifty warnings/shutdowns *Freeze* screens are saved. This data is saved during a power outage.

SYSTEM STATUS -Trending - Trending Setup

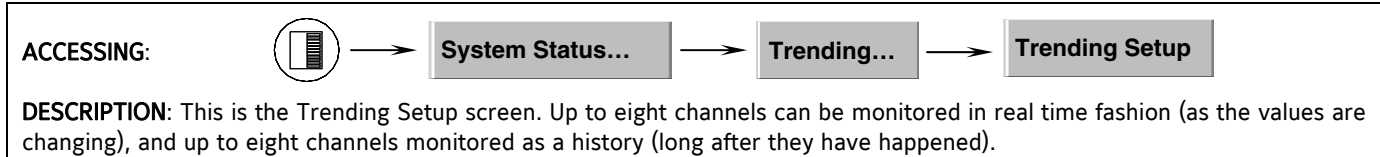

The following setpoints are provided:

Real Time Recording Interval – The time interval that defines how often the trending data values are recorded.

History Recording Interval – The time interval that defines how often the trending data values are recorded.

To program this screen with the data you wish to trend, the user would highlight the Enable Real Time Trend Channel 1 (or whatever channel they wish to use), by pressing the **[Tab]** key. Once the box is highlighted, use the **[Enter]** key to cause the possible settings for the channel to appear. Use the arrow keys to scroll through the list. When the selection that you want to use has been highlighted, press the **[Enter]** key to select it. Once selected, the value for this channel will be automatically trended and shown on the Real Time Trending graph (or History Trending Graph), as well as on the Real Time Trending Data Log (Or History Trending Data Log).

The following list is the selectable values that may be shown on this screen:

- Main Oil Injection Pressure
- Economizer Pressure
- Filter Pressure
- Intermediate Pressure
- Balance Piston Pressure
- System Discharge Pressure
- Suction Temperature
- Discharge Temperature
- Compressor Oil Temperature
- Oil Separator Temperature
- Process/Brine Temperature Leaving
- Process/Brine Temperature Entering
- Motor Current
- RPM
- User defined analog inputs #1 - #10
- EZ Cool Feedback %
- User defined analog inputs #12 - #20
- Manifold Pressure
- Compressor Vibration – Suction
- Compressor Vibration – Discharge
- Motor Vibration – Shaft Side
- Motor Vibration – Opposite Shaft Side
- Motor Temperature – Shaft Side
- Motor Temperature – Opposite Shaft Side
- Motor Stator #1
- Motor Stator #2
- Motor Stator #3
- NONE
- Capacity Slide Position
- Volume Slide Position
- Suction Pressure
- Discharge Pressure
- Compressor Oil Pressure

The following screen command keys are provided:

Upload Data Trending Files To USB Device - Pressing this key initiates an uploading of the Real Time and History data files. These files can then be imported into a database such as Excel™. To use this feature, simply plug a USB compatible device into the USB port of the Quantum™ LX. This device can be a USB cable that is connected directly to a personal computer, or a USB Flash Drive. When using a personal computer, and this button is selected, a window will appear on the computer screen, showing two files:

- Realtimexx.csv
- Historyxx.csv

The xx in both of these files will be replaced with the ID number of the Quantum™ LX. When the files appear in the screen window, simply right click on either file, and select from the menu "Save Target As...", and save the files to a convenient location. By using Windows Explorer™, you can then double click on the file, and it will automatically open the file in Microsoft Excel™. The data can then be used in whatever way the user would like.

When using a USB Flash Drive, simply click on the button, and the files will be saved to the Flash Drive. You may then take the Flash Drive and plug it into the USB port of a personal computer. The files may then be opened from the Flash Drive.

SYSTEM STATUS -Trending - Real Time Trending

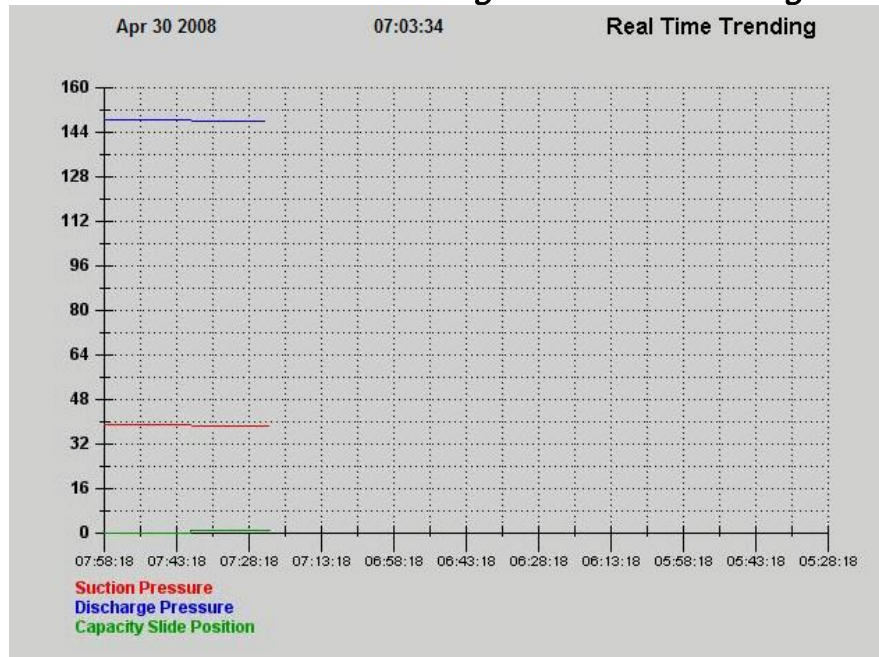

ACCESSING:



System Status...

Trending...

Real Time Trending

DESCRIPTION: This is the *Real Time Trending* screen. This screen will display in a graphical chart format, the data values as selected on the Real Time Trending Setup screen. Each of the possible eight selectable channels will be shown at the bottom of the screen, each in a different color. The color data values displayed in the chart, correspond to the matching color of the trending channels at the bottom of the screen.

A total of 900 Realtime events can be trended. Realtime events are lost upon each power cycle. The events that

can be logged are set using the Trending Setup screen, shown on the previous page.

SYSTEM STATUS -Trending - History Trending

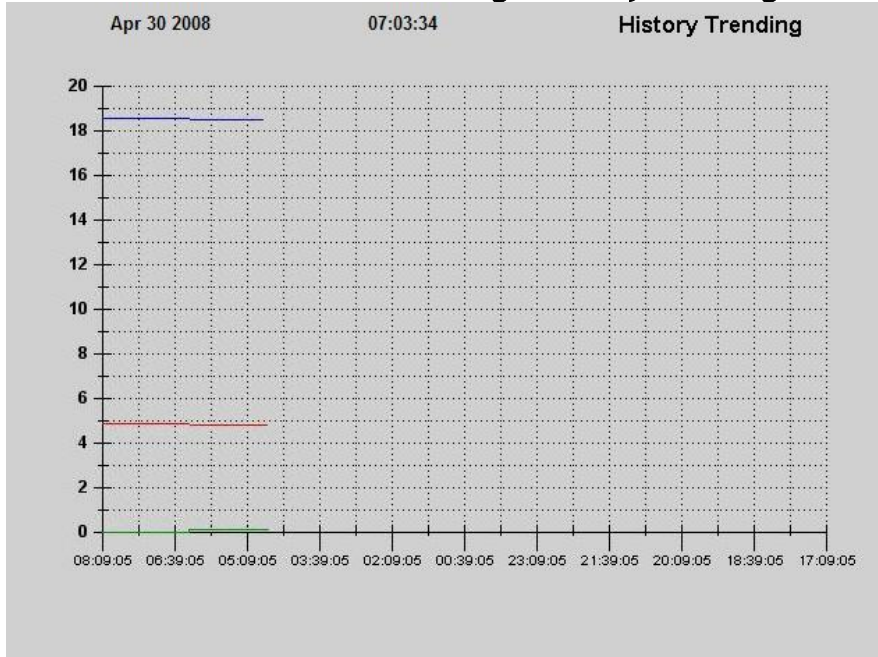

ACCESSING:



System Status...

Trending...

History Trending

DESCRIPTION: This is the *History Trending* screen. It is accessible from the *Main Menu* by pressing *System Status...*, then *Trending*, and finally *History Trending*. This screen will display in a graphical chart format, the data values as selected on the *Real Time Trending Setup* screen. Each of the possible eight selectable channels will be shown at the bottom of the screen, each in a different color. The color data values displayed in the chart, correspond to the matching color of the trending channels at the bottom of the screen.

History trending can save up to 2000 values for each selected channel. History data is stored in Flash memory. Flash memory is non-volatile and all information is retained even if the power to the panel is lost. The interval at which the data is saved can be adjusted.

The events that can be logged are set using the Trending Setup screen.

SYSTEM STATUS -Trending - Real Time Data Log

Apr 30 2008		07:10:40		Real Time Data Log	
1	04/30/08 07:10:39	-14.70	-14.70	0.00	
2	04/30/08 07:10:29	-14.70	-14.70	0.00	
3	04/30/08 07:10:19	-14.70	-14.70	0.00	
4	04/30/08 07:10:09	-14.70	-14.70	0.00	
5	04/30/08 07:09:59	-14.70	-14.70	0.00	
6	04/30/08 07:09:49	-14.70	-14.70	0.00	
7	04/30/08 07:09:39	-14.70	-14.70	0.00	
8	04/30/08 07:09:29	-14.70	-14.70	0.00	
9	04/30/08 07:09:19	-14.70	-14.70	0.00	
10	04/30/08 07:09:09	-14.70	-14.70	0.00	
11	04/30/08 07:08:59	-14.70	-14.70	0.00	
12	04/30/08 07:08:49	-14.70	-14.70	0.00	
13	04/30/08 07:08:39	-14.70	-14.70	0.00	
14	04/30/08 07:08:29	-14.70	-14.70	0.00	
15	04/30/08 07:08:19	-14.70	-14.70	0.00	
16	04/30/08 07:08:09	-14.70	-14.70	0.00	
17	04/30/08 07:07:59	-14.70	-14.70	0.00	
18	04/30/08 07:07:49	-14.70	-14.70	0.00	
19	04/30/08 07:07:39	-14.70	-14.70	0.00	
20	04/30/08 07:07:29	-14.70	-14.70	0.00	
21	04/30/08 07:07:19	-14.70	-14.70	0.00	
22	04/30/08 07:07:09	-14.70	-14.70	0.00	

Suction Pressure (PSIG)
Discharge Pressure (PSIG)
Motor Current (Amps)

ACCESSING:



System Status...

Trending...

Real Time Data Log

DESCRIPTION: This screen will display in a tabular format, the numerical data values as selected on the *Real Time Trending Setup* screen. Each of the possible eight selectable channels will be shown at the bottom of the screen, each in a different color. The color data values displayed in the chart, correspond to the matching color of the trending channels at the bottom of the screen.

The events that can be logged are set using the Trending Setup screen. Up to eight of these data selections may be activated at any one time. If eight items are selected, and

you wish to view one more, you will first need to deactivate one that is already chosen first.

SYSTEM STATUS -Trending - History Data Log

Apr 30 2008		07:11:59		History Data Log	
1	04/30/08 07:11:39	-14.70	-14.70	0.00	
2	04/30/08 07:10:39	-14.70	-14.70	0.00	
3	04/30/08 07:09:39	-14.70	-14.70	0.00	
4	04/30/08 07:08:39	-14.70	-14.70	0.00	
5	04/30/08 07:07:39	-14.70	-14.70	0.00	
6	04/30/08 07:06:39	-14.70	-14.70	0.00	
7	04/30/08 07:05:39	-14.70	-14.70	0.00	
8	04/30/08 07:04:39	-14.70	-14.70	0.00	
9	04/30/08 07:03:39	-14.70	-14.70	0.00	
10	04/30/08 07:02:39	-14.70	-14.70	0.00	
11	04/30/08 07:01:39	-14.70	-14.70	0.00	
12	04/30/08 07:00:39	-14.70	-14.70	0.00	
13	04/30/08 06:59:39	-14.70	-14.70	0.00	
14	04/30/08 06:58:39	-14.70	-14.70	0.00	
15	04/30/08 06:57:39	-14.70	-14.70	0.00	
16	04/30/08 06:56:39	-14.70	-14.70	0.00	
17	04/30/08 06:55:39	-14.70	-14.70	0.00	
18	04/30/08 06:54:39	-14.70	-14.70	0.00	
19	04/30/08 06:53:39	-14.70	-14.70	0.00	
20	04/30/08 06:52:39	-14.70	-14.70	0.00	
21	04/30/08 06:51:39	-14.70	-14.70	0.00	
22	04/30/08 06:50:39	-14.70	-14.70	0.00	

Suction Pressure (PSIG)
 Discharge Pressure (PSIG)
 Motor Current (Amps)

ACCESSING:  → **System Status...** → **Trending...** → **History Data Log**

DESCRIPTION: This screen will display in a tabular format, the numerical data values as selected on the *Real Time Trending Setup* screen. Each of the possible eight selectable channels will be shown at the bottom of the screen, each in a different color. The color data values displayed in the chart, correspond to the matching color of the trending channels at the bottom of the screen.

The events that can be logged are set using the Trending Setup screen.

SYSTEM STATUS - Maintenance

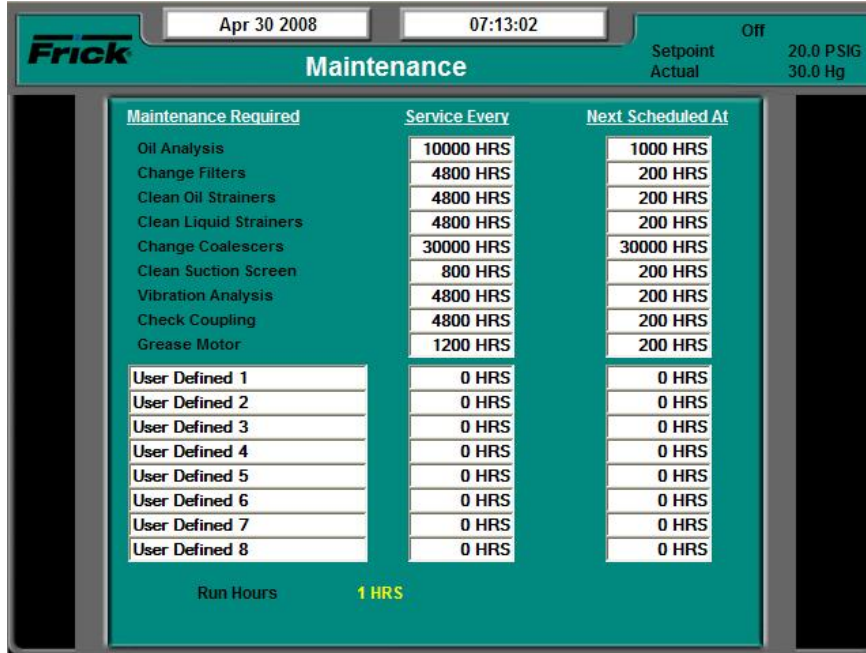

The screenshot shows the 'Maintenance' screen with the following data:

Maintenance Required	Service Every	Next Scheduled At
Oil Analysis	10000 HRS	1000 HRS
Change Filters	4800 HRS	200 HRS
Clean Oil Strainers	4800 HRS	200 HRS
Clean Liquid Strainers	4800 HRS	200 HRS
Change Coalescers	30000 HRS	30000 HRS
Clean Suction Screen	800 HRS	200 HRS
Vibration Analysis	4800 HRS	200 HRS
Check Coupling	4800 HRS	200 HRS
Grease Motor	1200 HRS	200 HRS
User Defined 1	0 HRS	0 HRS
User Defined 2	0 HRS	0 HRS
User Defined 3	0 HRS	0 HRS
User Defined 4	0 HRS	0 HRS
User Defined 5	0 HRS	0 HRS
User Defined 6	0 HRS	0 HRS
User Defined 7	0 HRS	0 HRS
User Defined 8	0 HRS	0 HRS

Run Hours: 1 HRS

ACCESSING:



DESCRIPTION: Using this screen, the user can view up to nine (9) pre-programmed maintenance schedules, as well as eight (8) user definable maintenance schedules. Each of the user defined schedules may be custom named. This screen is based upon the Maintenance Schedule that is provided in the IOM manual for the specific compressor package.

The usage of this screen is that the user can assign up to seventeen different areas of compressor operation that they would like to schedule routine maintenance for. As an example, the above screen shows a row labeled as *Oil Analysis*. The next column (Service Every) on the same row has a value of 10000 Hrs. The last column (Next Scheduled At) of this row has a value of 1000 Hrs. When the compressor is running, this time value is being clocked. After 1000 hours of compressor run time, a message will be generated and placed on the *Event Log* screen. This particular message will read *Maintenance -- Oil Analysis*. This is to notify the operator that it is time to have the Oil checked. At this point, the operator should notify the proper maintenance personnel that the appropriate maintenance be performed. The user should access the Event Screen on a regular basis (perhaps once per week) to review the information provided there.

Once the message has been entered in the *Event Log*, the values for the row will be automatically updated, with new values as predetermined by an internal programmed maintenance schedule, based upon the type of compressor. The values for the *Next Scheduled at* column are based upon the Compressor Run Time hours (shown at the bottom of this screen).

At the bottom of the left most column is the user defined *Maintenance Required* column. This is where custom names may be entered for the various items that the user would like to track.

Modifying numerical values

To modify any of the numerical boxes on this screen, simply use the **[Tab]** key to scroll down the lists, or the **[Left Arrow]** key to scroll up the lists. When the box that you wish to change is highlighted, you may enter the new value using the numerical keys, then press the **[Enter]** key to accept the value.

Modifying Text (User Defined) Boxes

To modify any of the text boxes on this screen, simply use the **[Tab]** key to scroll down the lists, or the **[Left Arrow]** key to scroll up the lists. When the box that you wish to change is highlighted, use the **[Up Arrow]** key. A new screen (*Alpha*) showing a numerical keypad will appear. Refer to the *Alpha* screen description for information on entering text messages. Press the **[Enter]** key to accept the text. The user may type in a custom name up to 20 characters long.

The following additional information is provided on this screen:

Run Hours - The value shown here are the total number of hours that the compressor motor has actually been in the running state. This value can be reset (or changed to any value from 0 to 1,000,000 Hours) from the *Panel* screen.

SYSTEM STATUS - Event Log

Event		Occurred
01	Power Up	01-26-09 14:46:11
02	Power Down	01-26-09 14:44:35
03	Software Maintenance Entered	01-26-09 14:45:34
04	Power Up	01-26-09 12:51:31
05	Power Down	01-26-09 12:50:17
06	Power Up	01-26-09 12:44:14
07	Power Down	01-26-09 12:42:06
08	Power Up	01-21-09 11:53:57
09	Power Down	01-21-09 11:48:57
10	Power Up	01-20-09 08:38:30
11	Power Down	01-20-09 08:16:09

ACCESSING:



→ **System Status...**

→ **Event Log**

DESCRIPTION: This screen is used to log certain messages and events that are generated through normal unit operation. Occurrences such as normal power up and power down sequences, as well as all maintenance schedule messages (see the *Maintenance* screen for more information on these messages).

The messages that appear on this screen cannot be cleared, they will be stored indefinitely.

The user can use the arrow keys on the keypad to scroll down through the list.

The left side of this screen is numbered for each event which has occurred. Under the Event heading, the specific event will be shown that caused a normal system event. In this case, Software Maintenance was performed at row 3.

The next column shows each time the control panel was powered down or powered up. This includes all cycling of power, whether intentional or not (a power failure will be shown as a power down/power up event).

The final column at the right side of the screen shows the date and the time of the event. It is very important to ensure that the correct Date and Time are set, so that accurate event logging can be maintained.

SYSTEM STATUS - VSD Energy Savings

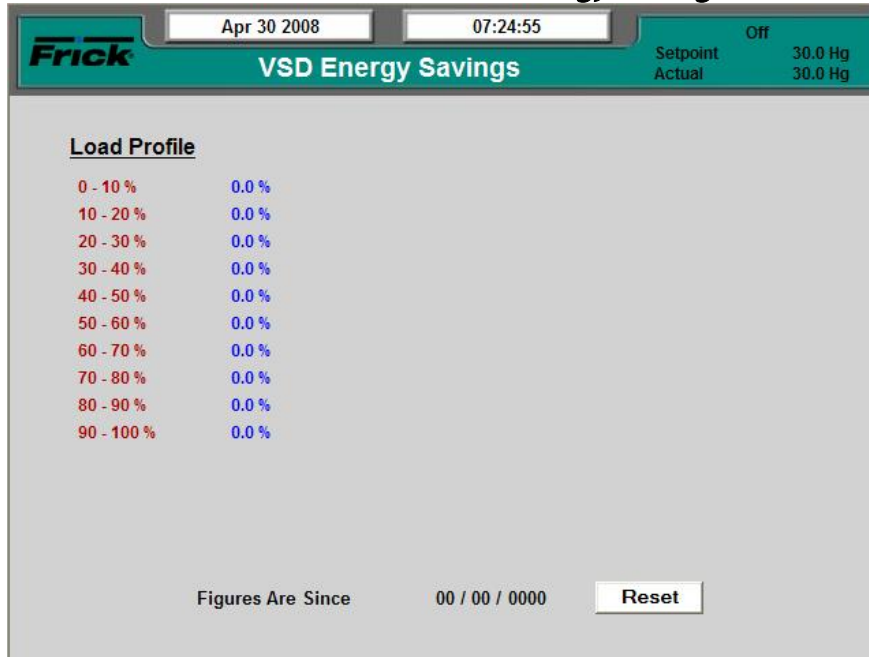

Load Range	Percentage
0 - 10 %	0.0 %
10 - 20 %	0.0 %
20 - 30 %	0.0 %
30 - 40 %	0.0 %
40 - 50 %	0.0 %
50 - 60 %	0.0 %
60 - 70 %	0.0 %
70 - 80 %	0.0 %
80 - 90 %	0.0 %
90 - 100 %	0.0 %

Figures Are Since 00 / 00 / 0000

ACCESSING:  → **System Status...** → **VSD Energy Savings**

DESCRIPTION: This screen provides a Slide Valve profile for the compressor.

The total time that the compressor is in the Running state since the date at the bottom of the screen is divided among the ten ranges listed in the left column. These ranges represent Slide Valve position, and the number to the right of the given range represents the percentage of

time that the Slide Valve is in that range. The percentages in the right column will add up to 100%. Tapping the reset button will reset the percentages to 0% and will set the date beside the reset button to the current date.

SETPOINTS - Capacity Control - Mode 1

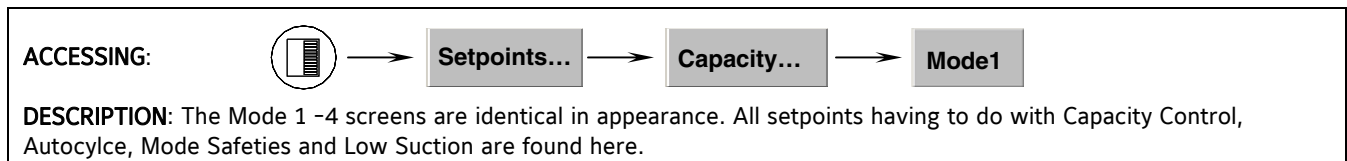
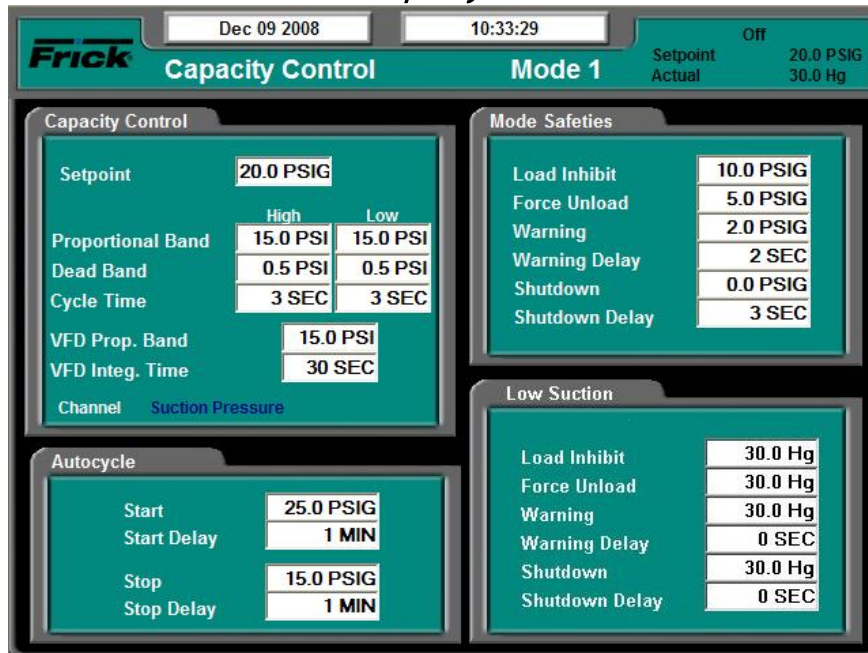

CAPACITY CONTROL - The following setpoint boxes are provided:

Setpoint - This setpoint is used to control the loading and unloading of the compressor when the Slide Valve Position is in the Automatic (AUTO) mode.

Proportional Band High - A band, measured in the units of the Capacity Control setpoint, above the *Dead Band High*, where proportional load control is used. If the actual reading rises into this proportional band, the load output will be pulsed as explained below in the description about proportional band.

Proportional Band Low - A band, measured in the units of the Capacity Control setpoint, below the *Dead Band Low*, where proportional unload control is used. If the actual reading falls into this proportional band, the unload output will be pulsed.

Dead Band High - A band, measured in the units of the Capacity Control setpoint, above the setpoint at which the compressor will neither load nor unload.

Dead Band Low - A band, measured in the units of the Capacity Control setpoint, below the setpoint at which the compressor will neither load nor unload.

Cycle Time High - This setpoint determines the amount of time in seconds that the load output is on

and off, when in the upper proportional band. Refer to the above description about cycle time.

Cycle Time Low - This setpoint determines the amount of time in seconds that the unload output is on and off, when in the lower proportional band. Refer to the above description about cycle time.

The following status indicator is provided:

Channel - Shows which analog channel is being used to control this mode. The possible states of this indicator are:

- Capacity Slide Position
- Volume Slide Position
- Suction Pressure
- Discharge Pressure
- Compressor Oil Pressure
- Main Oil Injection Pressure
- Economizer Pressure
- Filter Pressure
- Intermediate Pressure
- Balance Piston Pressure
- System Discharge Pressure
- Suction Temperature
- Discharge Temperature
- Compressor Oil Temperature
- Oil Separator Temperature
- Process/Brine Temperature Leaving

- Process/Brine Temperature Entering
- Motor Current
- RPM
- User defined analog inputs #1 - #10
- EZ Cool Feedback
- User defined analog inputs #12 - #20
- Manifold Pressure
- Compressor Vibration – Suction
- Compressor Vibration – Discharge
- Motor Vibration – Shaft Side
- Motor Vibration – Opposite Shaft Side
- Motor Temperature – Shaft Side
- Motor Temperature – Opposite Shaft Side
- Motor Stator #1
- Motor Stator #2
- Motor Stator #3

AUTOCYCLE - The following setpoint boxes are provided:

Start - The compressor is started at this setpoint when it is under automatic control.

Start Delay - The minimum time in minutes that the actual Capacity Control value must equal or exceed the start autocycle (automatic cycling) setpoint before the compressor will start. This timer helps prevent cycling a compressor on and off due to short or sudden changes in load within the refrigeration system.

Stop- The compressor is stopped at this setpoint when it is under automatic control.

Stop Delay - The minimum time in minutes that the actual Capacity Control value must equal or exceed the stop autocycle (automatic cycling) setpoint before the compressor will stop. This timer helps prevent cycling a compressor on and off due to short or sudden changes in load within the refrigeration system.

MODE SAFETIES - The following setpoint boxes are provided (**NOTE:** This box will be empty if either Manifold Pressure or Motor Current has been selected as the Mode control):

- Load Inhibit
- Force Unload
- Warning
- Warning Delay
- Shutdown
- Shutdown Delay

Each of the four Modes has a set of Safeties and Low Suction Safeties. Additionally, each also has a Control Channel and is configured with a Control Direction of either *Forward* or *Reverse*. The Safety Setpoints monitor the Control Channel for their Mode.

If the Control Direction for a Mode is set to *Forward*, its Safeties are activated as the Control Channel's value drops below the Safety Setpoints.

Example:

Control Channel = Process Temperature
Control Direction = Forward
Safety Warning Setpoint = 35.0 F

Note: For the above conditions a Warning will occur if the Process Temperature drops below 35.0 F.

If the Control Direction for a Mode is set to *Reverse*, its Safeties are activated as the Control Channel's value rises above the Safety Setpoints.

Example:

Control Channel = Discharge Pressure
Control Direction = Reverse
Safety Load Inhibit Setpoint = 170.0 PSIG

Note: For the above conditions a Load Inhibit condition will occur if the Discharge Pressure rises above 170.0 PSIG.

If a Mode's Control Channel is set to *Suction Pressure*, and its Control Direction is set to *Forward*, then both the Safeties and the Low Suction Safeties are checking for the same conditions. In this case, it is recommended that one group of safeties be set lower than the other group so that only one group will be actively monitoring the channel. Otherwise, duplicate Warning and Shutdown messages would be shown that could be confusing.

LOW SUCTION - The following setpoint boxes are provided (**NOTE:** This box will be empty if Suction Pressure has been selected as the Mode control):

- Load Inhibit
- Force Unload
- Warning
- Warning Delay
- Shutdown
- Shutdown Delay

SETPOINTS - Sequencing - System 1 Setup

ACCESSING:  → **Setpoints...** → **Sequencing...** → **System 1 Setup**

DESCRIPTION: This screen will be available if Sequencing is enabled in *Compressor* configuration. The screen shown here represents System 1. There are additionally a System 2 and a System 3 setup screens, which are not discussed further here, as all three screens show the same layout, although they may get setup using different capacity modes. Use these screens to setup all of the necessary operating parameters for performing compressor sequencing. The information from these three screens will be shown on the *Sequencing Status* screen.

The following pull-down menus and setpoint boxes are shown here:

Sequencing - Use this menu to set the current condition of System 1:

- **Disabled** - The compressors that are listed on this screen will not run as part of the sequencing scheme (System 1 will be ignored).
- **Enabled** - The compressors that are listed on this screen will run when called for as part of the sequencing scheme (System 1 will be included).

Setpoint - Use this setpoint box to set the value that you wish all compressors within this System to maintain.

Control Point - This is the actual value for the capacity control (as measured from the Master compressor). The master compressor is the unit with the lowest number shown on the Start list. It is to this value that the compressors will attempt to maintain. This is strictly a displayed value, and cannot be changed here.

Minimum Run Time - This is the minimum amount of time that each compressor within this system will run, when called upon to do so.

High Stage System Link - The High Stage System Link setpoint is provided to tie a system of Booster compressors to a system of High Stage compressors.

The following is an informational box only:

IP Address - Each compressor will have a different IP Address. This value should be entered by the network or LAN administrator, and will be shown here. Use the last three digits of this number for setting the Sequencing ID number for each compressor within the system. For example, from the IP shown on this screen, use 194 to enter into one of the eight Sequencing ID boxes at the left of the screen. This will identify which compressor is being communicated to with sequencing instructions.

There are eight rows of setpoint boxes shown at the bottom of this screen. These rows correspond to up to eight different compressors, which combined will make up this system. The user may program as few or as many of these rows as their situation requires:

Sequencing ID - Enter the last octet of the IP Address here. This will identify each of the possible eight compressors to the Master. A row with a 0 (zero) as the sequencing ID will be ignored. The lowest number will identify which compressor is to be the Master. If the Master is for some reason turned off, the next lowest numbered compressor will become the Master, and so on.

Start # - The allowable numbers here are 0 - 8. This number determines which compressor to start or stop next, based upon capacity need (see pages 13 - 14). Entering a 0 (zero) in this field will exclude the compressor from starting consideration.

- Automatic
- Remote Comm
- Remote 4-20
- Remote IO
- Remote Seq.

Compressor Mode -

- Manual
- Automatic
- Remote Comm
- Remote IO
- Remote Seq.

Capacity Mode -

- Manual

Minimum Capacity - This is the capacity that a compressor will load to when it is started. It will remain at or above this capacity until it is commanded to stop.

NOTE: The Compressor Mode and Capacity Mode listed above should both be set to Remote Seq. for complete execution of the sequencing system by the master to occur.

SETPOINTS - Compressor Safeties

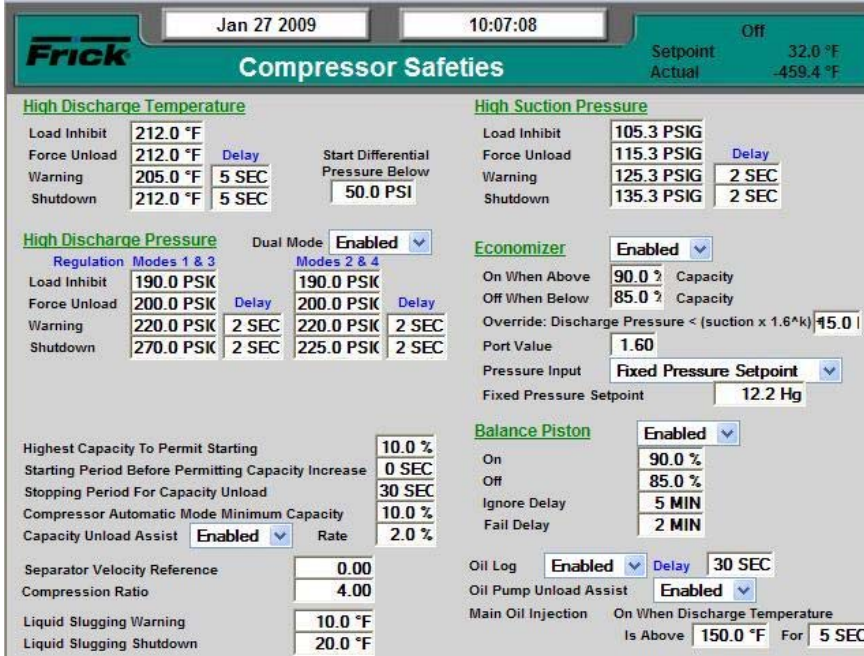

The screenshot shows the 'Compressor Safeties' control panel interface. At the top, it displays the date 'Jan 27 2009' and time '10:07:08'. The main title is 'Compressor Safeties'. On the right, there are 'Setpoint' and 'Actual' values for a parameter, with 'Setpoint' at 32.0 °F and 'Actual' at -459.4 °F. The interface is divided into several sections:

- High Discharge Temperature:** Includes 'Load Inhibit' (212.0 °F), 'Force Unload' (212.0 °F), 'Warning' (205.0 °F, 5 SEC), and 'Shutdown' (212.0 °F, 5 SEC). It also has a 'Start Differential Pressure Below' setpoint of 50.0 PSI.
- High Discharge Pressure:** Includes 'Load Inhibit' (190.0 PSK), 'Force Unload' (200.0 PSK), 'Warning' (220.0 PSK, 2 SEC), and 'Shutdown' (270.0 PSK, 2 SEC). It also features a 'Dual Mode' dropdown set to 'Enabled' and two columns of setpoints for 'Modes 1 & 3' and 'Modes 2 & 4'.
- High Suction Pressure:** Includes 'Load Inhibit' (105.3 PSIG), 'Force Unload' (115.3 PSIG), 'Warning' (125.3 PSIG, 2 SEC), and 'Shutdown' (135.3 PSIG, 2 SEC).
- Economizer:** Includes 'On When Above' (90.0 % Capacity), 'Off When Below' (85.0 % Capacity), 'Override: Discharge Pressure < (suction x 1.6^k)' (45.0), 'Port Value' (1.60), and 'Pressure Input' (Fixed Pressure Setpoint, 12.2 Hg).
- Balance Piston:** Includes 'On' (90.0 %), 'Off' (85.0 %), 'Ignore Delay' (5 MIN), and 'Fail Delay' (2 MIN).
- Other Parameters:** Includes 'Highest Capacity To Permit Starting' (10.0 %), 'Starting Period Before Permitting Capacity Increase' (0 SEC), 'Stopping Period For Capacity Unload' (30 SEC), 'Compressor Automatic Mode Minimum Capacity' (10.0 %), 'Capacity Unload Assist' (Enabled, Rate 2.0 %), 'Separator Velocity Reference' (0.00), 'Compression Ratio' (4.00), 'Liquid Slugging Warning' (10.0 °F), and 'Liquid Slugging Shutdown' (20.0 °F).
- Oil Log:** Includes 'Oil Log' (Enabled, Delay 30 SEC), 'Oil Pump Unload Assist' (Enabled), and 'Main Oil Injection' (On When Discharge Temperature Is Above 150.0 °F For 5 SEC).

ACCESSING:  → **Setpoints...** → **Compressor**

DESCRIPTION: Compressor safeties are important for the safe operation of the compressor.

The following pull-down menus and setpoint boxes are shown here:

High Discharge Temperature:

- **[Load Inhibit]** - The compressor Slide Valve will be prevented from loading until the Discharge Temperature is less than this setpoint.
- **[Force Unload]** - When the Discharge Temperature is greater than or equal to this setpoint, the compressor Slide Valve will be forced to Unload.
- **[Warning and delay]** - If the Discharge Temperature is greater than or equal to

this setpoint, for the alarm time delay, a warning occurs.

- **[Shutdown and delay]** - If the Discharge Temperature is greater than or equal to this setpoint, for the shutdown time delay, the compressor will shut down.
- **[Start Differential Pressure Below]** - The compressor will be inhibited from starting if the difference between the Discharge Pressure minus the Suction Pressure is greater than this setpoint.

High Discharge Pressure:

- **[Load Inhibit]** - The compressor Slide Valve will be prevented from loading until the Discharge Pressure is less than this setpoint.

- **[Force Unload]** - When the Discharge Pressure is greater than or equal to this setpoint, the compressor Slide Valve will be forced to Unload.
- **[Warning and delay]** - If the Discharge Pressure is greater than or equal to this setpoint, for the warning time delay, a warning occurs.
- **[Shutdown and delay]** - If the Discharge Pressure is greater than or equal to this setpoint, for the shutdown time delay, the compressor will be shut down.
- **[Highest Capacity to Permit Starting]** - The Slide Valve position must be equal to or less than this setpoint to allow the compressor to start.
- **[Starting Period Before Permitting Capacity Increase]** - This setpoint indicates the time period after the compressor goes to the Running State that the Slide Valve will not be allowed to load.
- **[Stopping Period for Capacity Unload]** - When the compressor is commanded to stop, the Slide Valve will unload for this period, or until the Slide Valve is at or below the *Highest Capacity to Permit Starting* setpoint.
- **[Compressor Automatic Mode Maximum Capacity]** - When the compressor is Running and the Compressor Mode and Capacity Modes are both in Automatic, the Slide Valve will be loaded so as to keep the Capacity at or above this setpoint.
- **[Capacity Unload Assist]**

High Suction Pressure

- **[Load Inhibit]** - The compressor Slide Valve will be prevented from loading until the Suction Pressure is less than this setpoint.
- **[Force Unload]** - When the Suction Pressure is greater than or equal to this setpoint, the compressor Slide Valve will be forced to Unload.
- **[Warning and delay]** - If the Suction Pressure is greater than or equal to this setpoint, for the warning time delay, a warning occurs.
- **[Shutdown and delay]** - If the Suction Pressure is greater than or equal to this setpoint, for the shutdown time delay, the compressor will be shut down.

Economizer Control - This is a digital output (module 11 on digital board #1).

- **[Economizer]**
 - Disabled - Output is off.
 - Enabled - If the compressor is running, the *On When Above* and *Off When Below* setpoints take effect, and the Capacity is compared to these setpoints to determine when to turn the output on or off.
- **[Override]** - Used to turn the output off if the Discharge Pressure < (suction x 1.6^k) plus the Override setpoint.

Economizer VI Control - When economizing, the added volume of the gas that is entering the side port needs to be accounted for in the VI calculation. Failure to do so would result in over-compensation and high energy usage. When the compressor is running and the Economizer output is energized, the following control settings will be active:

- **[Port Value]** - If the Economizer is On and the Pressure Input selection is not Disabled, this setpoint is used in calculating the Volume Ratio. A value of 1.6 is used for RXF models, and a value of 1.4 is used for RWF models.
- **[Pressure Input]**
 - Disabled
 - Fixed Pressure Setpoint - If this is selected, then this setpoint is used to calculate the Volume Ratio.
 - Economizer Analog Input - If this is selected, then this Input value will be used in calculating the Volume Ratio.

Balance Piston - This is a digital output.

- **[Balance Piston]**
 - Disabled - Output is off.
 - Enabled - When Enabled, and if the compressor is running, the output is controlled by comparing the Slide Valve positions to the *On* and *Off* setpoints
- **[Ignore Delay]** - The length of time that the Balance Piston safety checks are not performed.
- **[Fail Delay]** - Delay Period for the Balance Piston safety checks.
- **[Oil Log]**
 - Disabled - Oil Log is disabled.
 - Enabled - If for the Oil Log Delay setpoint period, the oil pump has been on and the compressor is Off or Starting without going into Running, an Oil Log shutdown will occur.
- **[Oil Pump Unload Assist]**
 - Disabled - *Oil Pump Unload Assist* is disabled.
 - Enabled - *Oil Pump Unload Assist* is enabled.
- **[Main Oil Injection]**
 - Is Above (Setpoint) - The *Main Oil Injection* output will energize when the Discharge Temperature exceeds this setpoint.
 - For (Delay) - Once the *Main Oil Injection* output has been energized by the above setpoint, it will remain energized for this amount of time.

SETPOINTS - *Package Safeties*

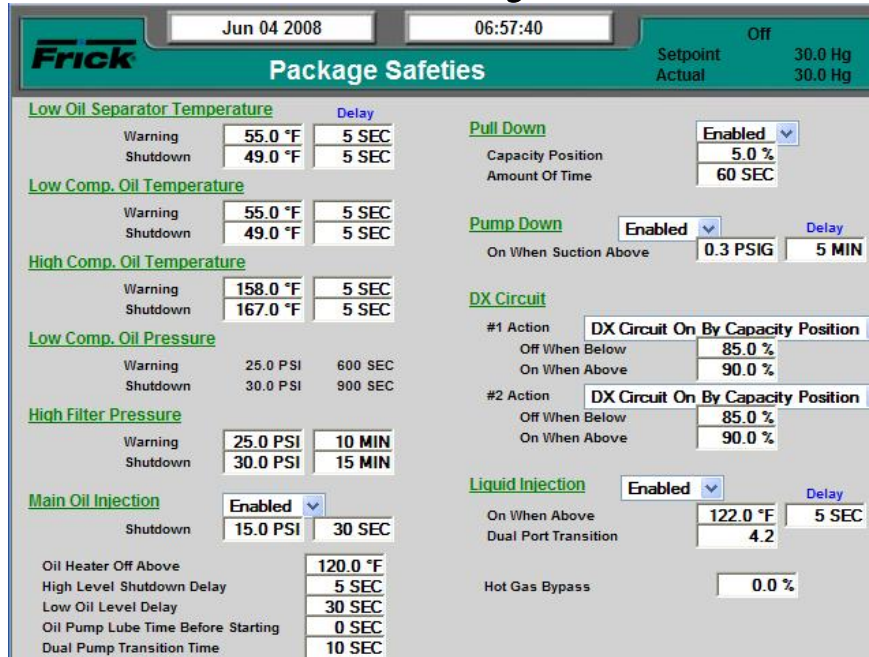
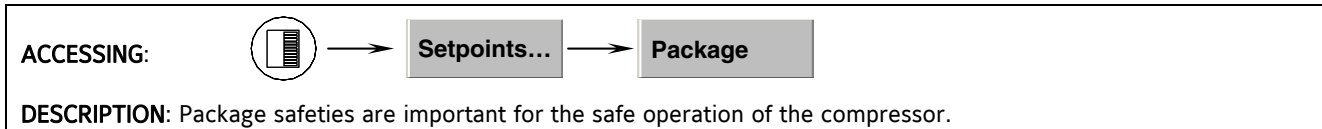
The following pull-down menus and setpoint boxes may be shown here:

Low Oil Separator Temperature:

- **[Warning]** - If the *Oil Separator Temperature* is less than or equal to this setpoint, for the warning alarm time delay, a warning occurs.
- **[Warning Delay]** - The minimum time in seconds that the *Oil Separator Temperature* is less than or equal to the *Low Oil Separator Temperature Warning* setpoint before notification of the warning.
- **[Shutdown]** - If the *Oil Separator Temperature* is less than or equal to this setpoint, for the shutdown time delay, the compressor will shut down.
- **[Shutdown Delay]** - The minimum time in seconds that the *Oil Separator Temperature* is less than or equal to the *Low Oil Separator Shutdown* setpoint before the compressor will shut down.

Low Oil Temperature:

- **[Warning]** - If the *Oil Temperature* is less than or equal to this setpoint, for the warning time delay, a warning occurs.

- **[Warning Delay]** - The minimum time in seconds that the *Oil Temperature* is less than or equal to the *Low Oil Warning* setpoint before notification of the warning.
- **[Shutdown]** - If the *Oil Temperature* is less than or equal to this setpoint, for the shutdown time delay, the compressor will shut down.
- **[Shutdown Delay]** - The minimum time in seconds that the *Oil Temperature* is less than or equal to the *Low Oil Shutdown* setpoint before the compressor will shut down.

High Oil Temperature:

- **[Warning]** - If the *Oil Temperature* is greater than or equal to this setpoint, for the warning time delay, a warning occurs.
- **[Warning Delay]** - The minimum time in seconds that the *Oil Temperature* is greater than or equal to the *High Oil Temperature Warning* setpoint before notification of the warning.

- **[Shutdown]** - If the *Oil Temperature* is greater than or equal to this setpoint, for the

shutdown time delay, the compressor will shut down.

- **[Shutdown Delay]** - The minimum time in seconds that the *Oil Temperature* is greater than or equal to the *High Oil Temperature Shutdown* setpoint before the compressor will shut down.

Low Oil Pressure:

- **[Warning]** - If the *Oil Pressure* is less than or equal to this setpoint, for the warning time delay, a warning occurs.
- **[Warning Delay]** - The minimum time in seconds that the *Oil Pressure* is less than or equal to the *Low Oil Pressure Warning* setpoint before notification of the warning.
- **[Shutdown]** - If the *Oil Pressure* is less than or equal to this setpoint, for the shutdown time delay, the compressor will shut down.
- **[Shutdown Delay]** - The minimum time in seconds that the *Oil Pressure* is less than or equal to the *Low Oil Pressure Shutdown* setpoint before the compressor will shut down.

High Filter Pressure:

- **[Warning]** - If the *Filter Pressure* is greater than or equal to this setpoint, for the warning time delay, a warning occurs.
- **[Warning Delay]** - The minimum time in seconds that the *Filter Pressure* is greater than or equal to the *High Filter Pressure Warning* setpoint before notification of the warning.
- **[Shutdown]** - If the *Filter Pressure* is greater than or equal to this setpoint, for the shutdown time delay, the compressor will shut down.
- **[Shutdown Delay]** - The minimum time in seconds that the *Filter Pressure* is greater than or equal to the *High Filter Pressure Shutdown* setpoint before the compressor will shut down.
- **[High Level Shutdown Delay]** - The time in seconds to delay after the *High Liquid Level* input is energized before the compressor will shut down.

- **[Low Oil Level Delay]** - The time that must elapse before the *Low Oil Level Shutdown* can be initiated.
- **[Oil Pump Lube Time Before Starting]** -
- **[Dual Pump Transition Time]** - If enabled. The lead pump is the pump selected to be the first pump to run. If the lead pump has a pump auxiliary failure, an alarm message is issued and the other pump will be turned on. If the compressor has a *Low Oil Pressure Warning* failure, the second pump will be turned on; then after a 30 seconds delay, the lead pump will be turned off. If while the compressor is running the second pump has an auxiliary failure or *Low Oil Pressure* is encountered, a shutdown message and action is issued.

Pull Down:

With this option enabled, the *Suction Pressure* can be slowly lowered in steps. Slowly walking the pressure down prevents rapid drops in system pressure that causes violent boiling of refrigerant in the system. The following selections are provided:

- **Disabled** - The Pull Down feature is ignored.
- **Enabled** - The Pull Down feature will be utilized.
- **[Capacity Position]** - The percentage of travel that the Slide Valve is permitted to load upon Compressor starting, and thereafter determined by the *Amount of Time* setpoint. For example, if this setpoint is 5%, and the Amount of Time setpoint is 1 Minute, then the Slide Valve will be permitted to load 5% of its stroke every minute, until such time as the compressor has reached capacity. It would take 20 minutes for the Slide Valve to fully load to 100% at this rate. Once capacity has been achieved, this function is ignored, until such time as the compressor is restarted.
- **[Amount of Time]** - The amount of time between when the Slide Valve is permitted to move. See Slide Valve Position description.

Pump Down:

With this option enabled, Pump Down provides for pumping down the refrigerant (removal of the refrigerant gas). For example, this can be used

for removing the refrigerant from a shell and tube heat exchanger to prevent its standing water from freezing. When Pump Down is enabled and the compressor is stopped the DX circuits digital outputs are de-energized but the compressor remains running for the delay period. When the delay period times out, or the Suction Pressure falls below the *On When Suction Above* setpoint, the compressor is turned off. To force a compressor that is in Pump Down to stop, press the compressor stop screen command key again.

The following selections are provided:

- **Disabled** - The Pump Down feature is ignored.
- **Enabled** - The Pump Down feature will be utilized.
- **[On When Suction Above]** - After sending the compressor stop command, if the Suction Pressure reading is above this setpoint, Pump Down will be invoked. In Pump Down, the compressor will stay on to continue vaporizing the refrigerant.
- **[On When Suction Above Delay]** - The amount of time in minutes the compressor will Pump Down before it is stopped.

DX Circuit - The following are digital outputs:

- **[#1 Action]:**
 - Disabled - DX Circuit #1 is off.
 - DX Circuit On with compressor - DX Circuit #1 is on if the compressor is on, or it is off if the compressor is off.
 - DX Circuit On by Capacity Position - When this option is selected, two other setpoints are shown:
 - Off When Below.
 - On When Above.

DX Circuit #1 is turned On when the Capacity Position is above the *On When Above* setpoint, and it is turned Off when the Capacity Position is below the *Off When Below* setpoint.

- **[#2 Action]:**
 - Disabled - DX Circuit #2 is off.
 - DX Circuit On with compressor - DX Circuit #2 is on if the compressor is on, or it is off if the compressor is off.
 - DX Circuit On by Capacity Position - When this option is selected, two other setpoints are shown:
 - Off When Below.
 - On When Above.

DX Circuit #2 is turned On when the Capacity Position is above the *On When Above* setpoint, and it is turned Off when the Capacity Position is below the *Off When Below* setpoint.

Liquid Injection:

This is only available if the compressor has Liquid Injection oil cooling and it has been enabled. Liquid Injection controls the supply of liquid refrigerant to the compressor. Liquid Injection is off (the solenoid is closed) if the compressor is off.

- Disabled
- Enabled

[On When Discharge Temperature Above] and [Delay]

[Dual Port Transition]

[Hot Gas Bypass] - This option is available if it applies to the compressor model (Reference 090-020 M; *Compressor Model Differences*).

SETPOINTS - Drive

07:46:47
Apr 30 2008

Motor

Name Plate

Motor Amps: 100 AMPS
Volts: 480
Service Factor: 1.15
Horse Power: 100
CT Factor: 100

Recycle Delay: 20 MIN
Current Value: 00:00
Clear Recycle Delay

High Motor Amps

Load Inhibit: 100 AMPS
Force Unload: 105 AMPS Delay
Warning: 110 AMPS 5 SEC
Shutdown: 115 AMPS 5 SEC

Low Motor Amps

Shutdown: 25 AMPS 30 SEC
Confirmed Running Motor Amps: 20 AMPS
Starting Motor Amps Ignore Period: 5 SEC

VFD

Maximum Drive Output: 100.0 %
Minimum Drive Output: 50.0 %

Remote Control

Rate Of Increase: 2.0 % 1 SEC
Rate Of Decrease: 2.0 % 1 SEC

Capacity Control

The Drive Speed will increase and decrease proportionally with the Slide Valve*. When the Slide Valve* loads to 95.0 % the Drive Speed will reach 50.0 % . Above these setpoints the Drive Speed will be controlled by the Proportional Band and Integration Time while the Slide Valve* will operate independently.
*Slide Valve or other mechanical unloader

Variable Speed Minimum Slide Valve Position: 25.0 %
Note: Slide Valve Range limited to protect compressor

Skip Frequency Bands

Bottom	Top
0.0 %	0.0 %
0.0 %	0.0 %
0.0 %	0.0 %
0.0 %	0.0 %
0.0 %	0.0 %

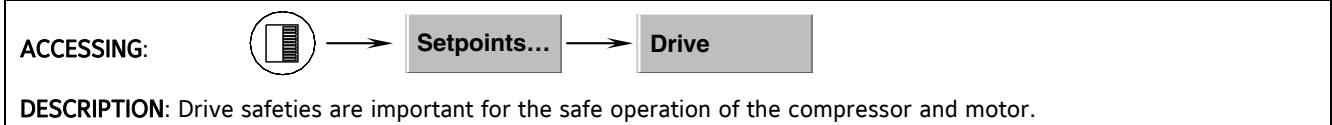

The following pull-down menus and setpoint boxes are shown here. This information should be recorded from the motor nameplate:

Name Plate:

- **[Motor Amps]** – Enter the value from the motor nameplate.
- **[Volts]** – Enter the value from the motor nameplate.
- **[Service Factor]** – Not required if using RAM DBS.
- **[Horse Power]** – Enter the value from the motor nameplate.
- **[CT Factor]** – The Current Transformer Factor is printed on the current transformer in the compressor motor starter. **Note:** Not required if using RAM DBS.

To verify that the CT has been sized properly, use the following equation:

$$CTF = FLA \text{ (Full Load Amps)} \times \text{Service Factor} \times 1.1 = \text{Recommended CT (Round up to next highest 100 Amps)}$$

EXAMPLE: FLA = 182 Amps
SF = 1.0
CTF = (182 x 1.0 x 1.1) = 200.2 >

Round up to 300 [use 300:5 CT]

- **[Recycle Delay]** – Each time the compressor is started, this value will be loaded into the Recycle Delay timer. This time must elapse prior to allowing the compressor to restart. The timer will time out while the compressor is running or stopped since the Recycle Delay is a start-to-start protection. The Recycle Delay time is intended to prevent damage to the motor from successive restarts.

NOTE: Consult Motor Manufacturer for the recommended duration of the Recycle Delay.

High Motor Amps:

- **[Load Inhibit]** – The compressor slide valve will be prevented from loading until the Motor Amps is less than this setpoint.

TYPICAL SETTING: Motor Amps Stop Load = FLA x 100%

- **[Force Unload]** – When the Motor Amps is greater than or equal to this setpoint, the compressor Slide Valve will be forced to unload.

TYPICAL SETTING: Motor Amps Force UnLoad = FLA x 105%

- **[Warning]** - If the Motor Amps is greater than or equal to this setpoint, for the warning time delay, a warning occurs.
- **[Warning Delay]** - The minimum time in seconds that the Motor Amps is greater than or equal to the *High Motor Amps Warning* setpoint before notification of the warning.
- **[Shutdown]** - If the Motor Amps is greater than or equal to this setpoint, for the shutdown time delay, the compressor will shut down.
- **[Shutdown Delay]** - The minimum time in seconds that the Motor Amps is greater than or equal to the *High Motor Amps Shutdown* setpoint before the compressor will shut down.

Low Motor Amps:

- **[Low Motor Amps Shutdown]** - This setpoint is used to determine if the coupling has broken. If the Motor Amps is less than or equal to this setpoint, for the shutdown time delay, the compressor will shut down.
- **[Low Motor Amps Shutdown Delay]** - The minimum time in seconds that the Motor Amps is less than or equal to the *Low Motor Amps Shutdown* setpoint before the compressor will shut down.
- **[Confirmed Running Motor Amps]** - The measured Motor Amps must be greater than or equal to this setpoint before the compressor will transition from Starting to Running.

- **[Starting Motor Amps Ignore Period]** - After the compressor is commanded to start, this setpoint indicates the period during which the *High Motor Amps Load Inhibit* and *Force Unload* checks are not performed.

VFD:

- **[Maximum Drive Output]** - Setpoint used to select the maximum operating speed of the VFD. Selectable from 1-100% of the 4-20 mA signal.
- **[Minimum Drive Output]** - Setpoint used to select the minimum operating speed of the VFD. Selectable from 1-100% of the 4-20 mA signal.
- **[Rate of Increase]**
- **[Rate of Increase Delay]**
- **[Rate of Decrease]**
- **[Rate of Decrease Delay]**

The following special selections are on this screen:

[Clear Remaining Delay] - This selection will clear the remaining delay time, allowing the motor to be re-started immediately. **WARNING!!!** *This may cause damage to the compressor motor.*

SETPOINTS - Miscellaneous

The screenshot displays the 'Miscellaneous' setpoints screen. At the top, it shows the date 'Apr 30 2008' and time '07:49:07'. The status is 'Off'. A table shows 'Setpoint' as 'Off' and 'Actual' as '30.0 Hg'. The main area contains several controls: 'Remote Capacity Deadband' set to '1.0 %'; 'High Comp. Oil Pressure' set to '50.0 PSI' with a '5 SEC' delay; 'Dewpoint Temp. Warning - Running' set to '20.0 °F' with a '5 MIN' delay; and 'Dewpoint Temp. Warning - Off' set to '2.0 °F' with a '5 MIN' delay. There is also a 'Heater Control Safety Factor' set to '5.0 °F'.

ACCESSING:  → **Setpoints...** → **Miscellaneous**

DESCRIPTION: This screen contains miscellaneous setpoints that don't fit in with the other categories of setpoint screens.

The following pull-down menus and setpoint boxes are shown here:

- **[Remote Capacity Deadband]** - When the Capacity Mode is set to Remote 4-20, this setpoint is used in conjunction with the Remote Capacity Position analog input to control (Load or Unload) the Slide Valve. (The Remote Capacity Position analog input value is the Capacity Position that you are trying to achieve).
- **[High Compressor Oil Pressure]**
 - Disabled
 - Enabled
- **[Shutdown]**
- **[Shutdown Delay]**
- **[Dewpoint Temp. Warning - Running]** - If enabled and the compressor is running, this will generate the warning *Condenser Water in Separator Warning* if for the *Safety Factor Delay* period the Discharge Temperature is less than the Dewpoint Temperature, which is calculated using the *Safety Factor* Setpoint.
 - Disabled
 - Enabled
- **[Dewpoint Temp. Warning - Off]** - If enabled and the compressor is off, this will generate the warning *Condenser Water in Separator Warning* if for the *Safety Factor Delay* period the Separator Temperature is less than the Dewpoint Temperature, which is calculated using the *Safety Factor* setpoint. Also, the sum of the Dewpoint Temperature and the *Heater Control Safety Factor* will be used in the control of the Oil Heater.
 - Disabled
 - Enabled

SETPOINTS - *Scheduling*

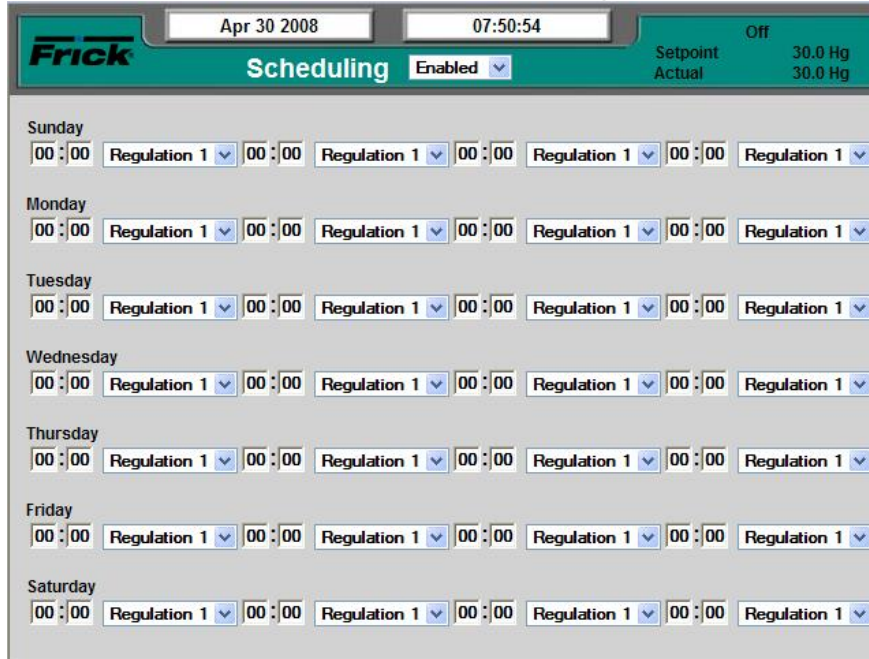

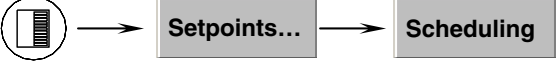
ACCESSING: 

DESCRIPTION: Scheduling allows the user to program up to four different operating schedules for each day of the week. This can be a great way to save energy. At night or on weekends and holidays, or even over lunch periods when room doors are kept closed, or production is minimized, a higher temperature can be set to reduce energy consumption.

This screen shows a time schedule. Up to four different modes can be entered for each day of the week. The Schedule is only effective if the compressor is in automatic.

Notice that there are four columns of Hour/Minute entries, each followed by a Regulation mode (1 - 4). Use the left most column (on the row for the day of the week that you wish to schedule) to enter the time of day that you would like the compressor to switch from it's normal operating mode, into the scheduled mode. When that time of day arrives, whatever mode the compressor WAS running in, will be switched over to the scheduled (Regulation 1 -4) mode. This mode will then be the active running mode, and will continue to be the active mode until the time in the following column is reached. If the time in the next column is 00:00, it will be skipped.

The Schedule must be activated to switch the presently active Regulation mode to the *Scheduling* regulation mode at the assigned time. An entry of 00:00 will void the

time entry field. If setback is required at midnight (00:00) use 00:01.

The following drop down menu is provided:

Scheduling

- **Enabled** - The user programmed Schedule will be followed.
- **Disabled** - The Quantum™ LX will ignore any schedule that may have been set.

The following are descriptions of the setpoints:

Time Column - The time of day that you want to switch to the Scheduled regulation setpoints of the active capacity control.

Mode Column - Set this to the Regulation Mode (1 - 4) that you want to run at the assigned time.

SETPOINTS - *Condenser Digital Control*

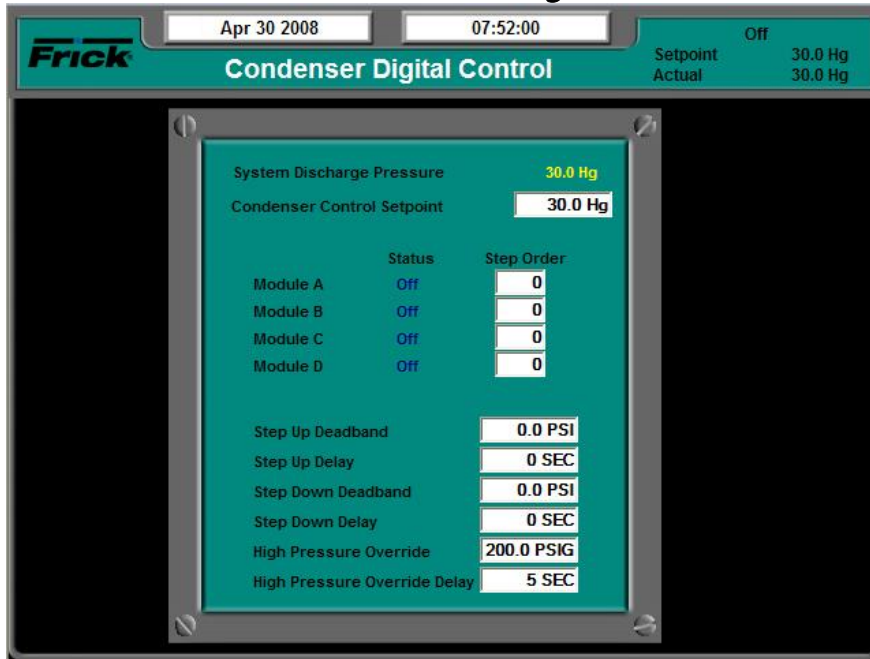

ACCESSING:  → **Setpoints...** → **Condenser** → **Condenser Digital Control**

DESCRIPTION: If *Condenser* is enabled, this screen allows the end user to enter and view the basic operating parameters related to condenser digital operation.

The following setpoint boxes are shown here:

- **[Condenser Control Setpoint]** – This is the value that the Condenser Control will attempt to maintain.
- **[Module A - D Step Order]** - The four different output modules are enabled by putting a number (1-4) into the Step Order setpoint boxes. These determine the order that the modules are turned on or off. If a Module has a 0 (zero) as it's Step Order setpoint, it is disabled from the control process.
- **[Step Up Deadband]** and **[Step Up Delay]** – When the *System Discharge Pressure* stays above the combined values of the *Condenser Control Setpoint* plus the *Step Up Deadband* for the amount of time as set in the *Step Up Delay*, the next module in the *Step Order* will turn on.
- **[Step Down Deadband]** and **[Step Down Delay]** – When the *System Discharge Pressure* stays below the difference of the values for *Condenser Control Setpoint* minus the *Step Down Deadband* for the amount of time as set in the *Step Up Delay*, the next module in the *Step Order* will turn off.
- **[High Pressure Override]** and **[High Pressure Override Delay]** - When the *System Discharge Pressure* goes and stays at or above the High Pressure Override value for the amount of time as set in the *High Pressure Override Delay*, all modules will turn on.

SETPOINTS - *Condenser Analog Control*



ACCESSING:  → **Setpoints...** → **Condenser** → **Condenser Analog Control**

DESCRIPTION: If *Condenser* is enabled, this screen allows the end user to enter and view the basic operating parameters related to condenser analog operation.

The following pull-down menus and setpoint boxes are shown here:

- **[Condenser Control Setpoint]** – This is the value that the Condenser Control will attempt to maintain.
- **[Analog Output A]** – If enabled, *Analog Output A* will output a percentage between the **Low Limit** and **High Limit** percentages if Digital Module A is on, and 0% when Digital Module A is off.
 - Disabled
 - Enabled
- **[Analog Output B]** – If enabled, *Analog Output B* will output a percentage between the **Low Limit** and **High Limit** percentages if Digital Module B is on, and 0% when Digital Module B is off.
 - Disabled
 - Enabled
- **[Proportional Band]** and **[Integration Time]** – The Proportional Band is based on where the System Discharge Pressure is relative to the Condenser Control Setpoint, Analog Output A and B will output percentages using a standard Proportional Band, Integration Time Algorithm.

SETPOINTS – PHD Monitoring

Compressor Bearing Vibration Monitoring

Suction End	High Warning	3.5 gF	99 SEC	Discharge End	High Warning	3.5 gF	99 SEC
	High Shutdown	10.0 gF	1 SEC		High Shutdown	10.0 gF	1 SEC

Motor Bearing Vibration Monitoring

Shaft Side	High Warning	3.5 gF	99 SEC	Opposite Shaft	High Warning	3.5 gF	99 SEC
	High Shutdown	10.0 gF	1 SEC		High Shutdown	10.0 gF	1 SEC

Motor Stator Temperature Monitoring

Stator #1	High Warning	302.0 °F	5 SEC	Stator #2	High Warning	302.0 °F	5 SEC
	High Shutdown	311.0 °F	5 SEC		High Shutdown	311.0 °F	5 SEC
Stator #3	High Warning	302.0 °F	5 SEC				
	High Shutdown	311.0 °F	5 SEC				

ACCESSING:  → **Setpoints...** → **PHD Monitoring**

DESCRIPTION: This screen is used to setup the vibration portion of PHD Vibration monitoring. This screen will only be available if the PHD Vibration option has been installed and enabled.

The following setpoint boxes are provided for both the Compressor and Motor:

[Compressor Bearing]

- Disabled
- Vibration Monitoring

Suction End [High Warning] - If the amount of vibration exceeds this setpoint for the amount of time as set for the *High Warning Delay*, then a Warning is issued.

Suction End [High Warning Delay] - The time period as set here will begin to time down if the amount of vibration exceeds that of the *High Warning*, and remains above. When this delay times out, a Warning will be issued.

Suction End [High Shutdown] - If the amount of vibration exceeds this setpoint for the amount of time as set for the *High Shutdown Delay*, then a Shutdown will occur, and the compressor is stopped.

Suction End [High Shutdown Delay] - The time period as set here will begin to time down if the amount of vibration exceeds that of the *High Shutdown*, and remains above. When this delay times out, a Shutdown will occur, and the compressor is stopped.

Discharge End [High Warning] - If the amount of vibration exceeds this setpoint for the amount of time as set for the *High Warning Delay*, then a Warning is issued.

Discharge End [High Warning Delay] - The time period as set here will begin to time down if the amount of vibration exceeds that of the *High Warning*, and remains above. When this delay times out, a Warning will be issued.

Discharge End [High Shutdown] - If the amount of vibration exceeds this setpoint for the amount of time as set for the *High Shutdown Delay*, then a Shutdown will occur, and the compressor is stopped.

Suction End [High Shutdown Delay] - The time period as set here will begin to time down if the amount of vibration exceeds that of the *High Shutdown*, and remains above. When this delay times out, a Shutdown will occur, and the compressor is stopped.

[Motor Bearing]

- Disabled
- Vibration Monitoring
- Temperature Monitoring

Shaft Side [High Warning] - If the amount of vibration exceeds this setpoint for the amount of time as set for the *High Warning Delay*, then a Warning is issued.

Shaft Side [High Warning Delay] - The time period as set here will begin to time down if the amount of vibration exceeds that of the *High Warning*, and remains above. When this delay times out, a Warning will be issued.

Shaft Side [High Shutdown] - If the amount of vibration exceeds this setpoint for the amount of time as set for the *High Shutdown Delay*, then a Shutdown will occur, and the compressor is stopped.

Shaft Side [High Shutdown Delay] - The time period as set here will begin to time down if the amount of vibration exceeds that of the *High Shutdown*, and remains above. When this delay times out, a Shutdown will occur, and the compressor is stopped.

Opposite Shaft [High Warning] - If the amount of vibration exceeds this setpoint for the amount of time as set for the *High Warning Delay*, then a Warning is issued.

Opposite Shaft [High Warning Delay] - The time period as set here will begin to time down if the amount of vibration exceeds that of the *High Warning*, and remains above. When this delay times out, a Warning will be issued.

Opposite Shaft [High Shutdown] - If the amount of vibration exceeds this setpoint for the amount of time as set for the *High Shutdown Delay*, then a Shutdown will occur, and the compressor is stopped.

Opposite Shaft [High Shutdown Delay] - The time period as set here will begin to time down if the amount of vibration exceeds that of the *High Shutdown*, and remains above. When this delay times out, a Shutdown will occur, and the compressor is stopped.

[Motor Stator]

- Disabled
- Temperature Monitoring

Stator #1 [High Warning] - If the amount of vibration exceeds this setpoint for the amount of time as set for the *High Warning Delay*, then a Warning is issued.

Stator #1 [High Warning Delay] - The time period as set here will begin to time down if the amount of vibration exceeds that of the *High Warning*, and remains above. When this delay times out, a Warning will be issued.

Stator #1 [High Shutdown] - If the amount of vibration exceeds this setpoint for the amount of time as set for the *High Shutdown Delay*, then a Shutdown will occur, and the compressor is stopped.

Stator #1 [High Shutdown Delay] - The time period as set here will begin to time down if the amount of vibration exceeds that of the *High Shutdown*, and remains above. When this delay times out, a Shutdown will occur, and the compressor is stopped.

Stator #2 [High Warning] - If the amount of vibration exceeds this setpoint for the amount of time as set for the *High Warning Delay*, then a Warning is issued.

Stator #2 [High Warning Delay] - The time period as set here will begin to time down if the amount of vibration exceeds that of the *High Warning*, and remains above. When this delay times out, a Warning will be issued.

Stator #2 [High Shutdown] - If the amount of vibration exceeds this setpoint for the amount of time as set for the *High Shutdown Delay*, then a Shutdown will occur, and the compressor is stopped.

Stator #2 [High Shutdown Delay] - The time period as set here will begin to time down if the amount of vibration exceeds that of the *High Shutdown*, and remains above. When this delay times out, a Shutdown will occur, and the compressor is stopped.

Stator #3 [High Warning] - If the amount of vibration exceeds this setpoint for the amount of time as set for the *High Warning Delay*, then a Warning is issued.

Stator #3 [High Warning Delay] - The time period as set here will begin to time down if the amount of vibration exceeds that of the *High Warning*, and remains above. When this delay times out, a Warning will be issued.

Stator #3 [High Shutdown] - If the amount of vibration exceeds this setpoint for the amount of time as set for the *High Shutdown Delay*, then a Shutdown will occur, and the compressor is stopped.

Stator #3 [High Shutdown Delay] - The time period as set here will begin to time down if the amount of vibration exceeds that of the *High Shutdown*, and remains above. When this delay times out, a Shutdown will occur, and the compressor is stopped.

SETPOINTS - PID Setup

Frick		Aug 12 2008	09:55:26	Off
PID Setup		Page 1		
		Setpoint	21.0 PSIG	
		Actual	20.3 PSIG	
Name	EZ Cool LIOC	PID #2	PID #3	PID #4
Control	Running	Disabled	Disabled	Disabled
Action	Forward	Forward	Forward	Forward
Control Point	Discharge Ten	Capacity Slide	Capacity Slide	Capacity Slide
IO Board	Analog Board	Analog Board	None	None
Output Channel	1	2	0	0
Output	0.0 %	0.0 %	0.0 %	0.0 %
Actual	134.9 °F	9.2 %	9.2 %	9.2 %
Setpoint	145.0 °F	0	0	0
Proportional Band	25.0 °F	0	0	0
Integration Time	30 SEC	30 SEC	30 SEC	30 SEC
High Limit	100.0 %	100.0 %	100.0 %	100.0 %
Low Limit	0.0 %	0.0 %	0.0 %	0.0 %
When Running Off Value	0.0 %	0.0 %	0.0 %	0.0 %

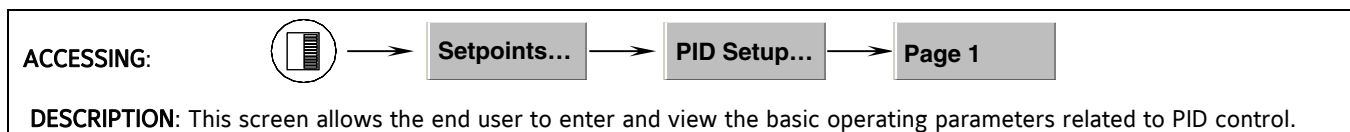

The following are the *PID Setup* screen selections:

[Name] - A user defined name can be entered here.

[Control] - A pull down menu is provided to select from the following:

- **Disabled** - No PID control.
- **Running** - PID Control only controls when the compressor is running.
- **Active** - PID control always active.

[Action] - A pull down menu is provided to select from the following:

- **Forward** - Will increase the output at values greater than the Control Setpoint.
- **Reverse** - Will increase the output at values less than the Control Setpoint.

[Control Point] - A pull down menu is provided to select from the following:

- Capacity Slide Position
- Volume Slide Position
- Suction Pressure
- Discharge Pressure
- Compressor Oil Pressure
- Main Oil Injection Pressure
- Economizer Pressure
- Filter Pressure
- Intermediate Pressure

- Balance Piston Pressure
- System Discharge Pressure
- Suction Temperature
- Discharge Temperature
- Compressor Oil Temperature
- Oil Separator Temperature
- Process/Brine Temperature Leaving
- Process/Brine Temperature Entering
- Motor Current
- RPM
- Auxiliary Analog 1 - 10
- EZ Cool Feedback %
- Auxiliary Analog 11 - 20
- Manifold Pressure
- Compressor Vibration - Suction
- Compressor Vibration - Discharge
- Motor Vibration - Shaft Side
- Motor Vibration - Opposite Shaft Side
- Motor Temperature - Shaft Side
- Motor Temperature - Opposite Shaft Side
- Motor Stator #1
- Motor Stator #2
- Motor Stator #3

[I/O Board] - A pull down menu is provided to select from the following:

- None
- Analog Board 1
- Analog Board 2

[Output Channel] - A setpoint entry box is provided to select the analog board output channel that you wish to use.

[Output] - The value of the Output signal as controlled by the PID. This is not a setpoint value.

[Actual] - The Actual value of the input signal. This is not a setpoint value.

[Setpoint] - Enter the value that you wish to control to.

[Proportional Band] - This setpoint determines the size of a region either above or below the *Control Setpoint*. Within this region, the Proportional component of the PID Output value is the number between 0% and 100% that directly corresponds to the difference between the *Control Input (Actual)* and the *Control Setpoint (Setpoint)*. Outside of this region, the Proportional component is either 100% or 0%. If the PID's *Action* is *Forward*, the *Proportional Band* extends above the *Control Setpoint*. If the PID's *Action* is *Reverse*, the *Proportional Band* extends below the *Control Setpoint*.

[Integration Time] - This setpoint controls the influence that the Integral component exerts on the PID Output value. The Integral component works to push the *Control Input* toward the *Control Setpoint* by tracking the difference between the *Control Input* and the *Control Setpoint* over time.

[High Limit] - The highest value that the output can be.

[Low Limit] - The lowest value that the output can be.

[When Running Off Value] - If the PID's Control is *When Running*, this value sets the value of the PID output when the compressor is off.

Setting up a PID Channel

NOTE: The basic steps in setting up a device for PID control is:

Setup Input channel

- First, decide which physical input channel you will be using. **Note: If you wish to use an Auxiliary Analog channel, it will require being completely setup as its own channel before attempting the remainder of this procedure.**

Setup PID parameters

- From the *Operating Status* screen, access the Menu. Scroll down and select the **[Setpoints]** key. At the *Setpoints* menu, scroll down to *PID Setup* and select it. Finally, on the *PID Setup* menu, select **[Page 1]**.

- On the *PID Setup* screen, use the **[Tab]** key to access the Analog channel that has already been set up, in this case, channel 1.
- It is on this Setup screen that the remainder of the PID parameters are entered. For a detailed description of these parameters, refer to the *Overview to Tuning a PID Controller*.

Note: Each device that is utilized for PID control must also be properly calibrated.

Overview to Tuning a PID Controller

The purpose of this section is to give some basic guidelines for tuning Proportional, Integral, and Differential gains of a PID controller. To tune a PID controller, it would be advantageous to hook the system up to some test equipment to allow you to record the appropriate variables. At the very least, the appropriate data will have to be monitored and recorded by hand from the system screen for subsequent evaluation and possible spreadsheet graphing.

Proportional Band

The *Proportional Band* setpoint translates the *Proportional Gain* into the units of the *Control Input* channel. When the control Input is at the *Control Setpoint*, the Proportional component of the PID Output will be 0%. As the *Control Input* moves through the *Proportional Band*, and away from the *Control Setpoint*, the Proportional component will increase. If the *Control Input* is in the middle of the *Proportional Band*, the Proportional component value is 50%, and when the *Control Input* reaches the outside of the *Proportional Band*, the Proportional value will be 100%. The value of the Proportional component is calculated as the difference between the *Control Input* and the *Control Setpoint*, divided by the *Proportional Band* and then multiplied by 100.

Example:

Control Input: Discharge Temperature
Control Setpoint: 100° F
Dead Band: 0° F
Proportional Band: 10° F
Action: Forward

Control Input	Proportional Output
100° F	0%
102.5° F	25%
105° F	50%
108° F	80%
110° F	100%
112° F	100%

The value selected for the *Proportional Band* will be determined by the stability of the system, the accuracy required, and the average output value, among other things. One way to pick a starting value is to find a range of allowable Control Input values and then to select a *Proportional Band* so that the Proportional value will reach 100% before the *Control Input* moves outside of the allowable range.

After the initial value is entered for the *Proportional Band*, watch the system to see how it reacts. If the PID output shows too much oscillation, increasing the Proportional Band will cause the control to react slower, which will dampen this oscillation. If the PID reacts too slowly, then decreasing the *Proportional Band* will make the control react faster.

Proportional Only Control - There will be certain applications in which only proportional control is required for good performance. When this is the case, the Integration Time can simply be set to zero, and the *Proportional Band* set to a desired value.

Some advantages of only using Proportional control are that it is generally more stable than Proportional and Integral control, and its function is easier to understand. A disadvantage of only using Proportional control is that the *Control Input* usually will settle into a spot somewhere in the *Proportional Band*, and will not move to the *Control Setpoint*. For instance, from the example shown above, if the *Proportional Output* averages 80%, then the *Control Input* will remain at 108° F and will not go to 100° F. This may be acceptable in some applications. In certain other cases the setpoint can be offset to move the *Control Input* to the point it needs to be.

Integration Time - The Integral calculation in PID control uses past performance to calculate a value for the PID output. It does this by periodically adding a small value to the PID output to move the *Control Input* toward the *Control Setpoint*. Eventually, the Integral component of the PID output will equal the average PID output value as *Control Input* gets to the *Control Setpoint*, and the Proportional component goes to 0%. When combined with the Integral calculation, the Proportional component can be negative and its range becomes -100% to +100%. If the *Control Input* moves above or below the *Control Setpoint*, the Proportional control will prevent it from moving too far, and the Integral control will move it back to the setpoint.

Once the *Proportional Gain* is set, start with a large Integration Time (180 seconds). Here again, you want to find the range of Integration Time that gives you reasonably fast performance, without too much overshoot, and without too much oscillation. If the *Control Input* repeatedly overshoots the *Control Setpoint*, or oscillates too much, increasing the *Integration Time* will slow the control. If the *Control Input* moves too slowly toward the *Control Setpoint*, decreasing the *Integration Time* will cause the control to react faster.

SETPOINTS - Superheat

	Superheat #1	Superheat #2	Superheat #3
Name	Superheat #1	Superheat #2	Superheat #3
Control	Always	Running	Disabled
Action	Forward	Forward	Forward
Control Pressure	Suction Press	Suction Press	Suction Press
Control Temperature	Discharge Te	Discharge Te	Discharge Te
Output Board	None	None	None
Output Channel	0	0	0
Output	0.0 %	0.0 %	0.0 %
Pressure	30.0 Hg	30.0 Hg	30.0 Hg
Temperature	-459.4 °F	-459.4 °F	-459.4 °F
Superheat	-163.7 °F	-163.7 °F	-163.7 °F
Setpoint	10.0 °F	10.0 °F	10.0 °F
Proportional Band	2.0 °F	2.0 °F	2.0 °F
Integration Time	180 SEC	180 SEC	180 SEC
High Limit	100.0 %	100.0 %	100.0 %
Low Limit	0.0 %	0.0 %	0.0 %
When Running Off Value	0.0 %	0.0 %	0.0 %
Refrigerant	R717		

ACCESSING:  → **Setpoints...** → **Superheat**

DESCRIPTION: This screen allows the end user to enter and view the basic operating parameters related to Superheat control.

The following are the *Superheat Control Setup* screen selections:

[Name] - A user defined name can be entered here.

[Control] - A pull down menu is provided to select from the following:

- **Disabled** - No Superheat control.
- **Running** - Superheat Control only controls when the compressor is running.
- **Active** - Superheat control always active.

[Action] - A pull down menu is provided to select from the following:

- **Forward** - Will increase the output at values greater than the Control Setpoint.
- **Reverse** - Will increase the output at values less than the Control Setpoint.

[Control Pressure] - A pull down menu is provided to select from the following:

- Suction Pressure
- Discharge Pressure
- Compressor Oil Pressure
- Main Oil Injection Pressure

- Economizer Pressure
- Filter Pressure
- Intermediate Pressure
- Balance Piston Pressure
- System Discharge Pressure
- User defined analog inputs #1 - #10
- EZ Cool Feedback %
- User defined analog inputs #12 - #20
- Manifold Pressure

[Control Temperature] - A pull down menu is provided to select from the following:

- Suction Temperature
- Discharge Temperature
- Compressor Oil Temperature
- Oil Separator Temperature
- Process/Brine Temperature Entering
- Process/Brine Temperature Leaving
- Auxiliary Analog 1 - 10
- EZ Cool Feedback %
- Auxiliary Analog 12 - 20

[Output Board] - A pull down menu is provided to select from the following:

- None
- Analog Board 1
- Analog Board 2

[Output Channel] - A setpoint entry box is provided to select the analog board output channel that you wish to use.

Output - The value of the Output signal as controlled by the Superheat. This is not a setpoint value.

Pressure - This is the value of the Control Pressure input signal. This is not a setpoint value.

Temperature - This is the value of the Control Temperature input signal. This is not a setpoint value.

Superheat - This is the calculated Superheat temperature based on the Temperature and Pressure described above. This is not a setpoint value.

[Setpoint] - Enter the value that you wish to control to.

[Proportional Band] - This setpoint determines the size of a region either above or below the *Control Setpoint*. Within this region, the Proportional component of the Superheat Output value is the number between 0% and 100% that directly

corresponds to the difference between the *Control Input* (Actual) and the *Control Setpoint* (Setpoint). Outside of this region, the Proportional component is either 100% or 0%. If the Superheat's *Action* is *Forward*, the *Proportional Band* extends above the *Control Setpoint*. If the Superheat's *Action* is *Reverse*, the *Proportional Band* extends below the *Control Setpoint*.

[Integration Time] - This setpoint controls the influence that the integral component exerts on the output value. The integral component works to push the calculated superheat value toward the setpoint by tracking the difference between the superheat value and the setpoint over time.

[High Limit] - The highest value that the output can be.

[Low Limit] - The lowest value that the output can be.

[When Running Off Value] - If the Superheat's Control is *When Running*, this value sets the value of the Superheat output when the compressor is off.

SETPOINTS - Recip

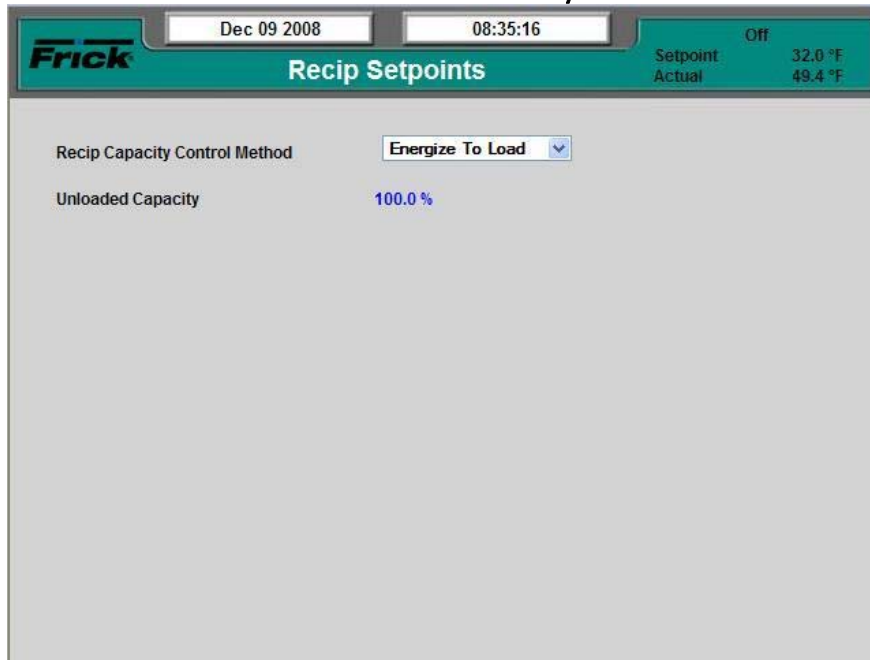

ACCESSING:



Setpoints...

Recip

DESCRIPTION: This screen will only be accessible if the compressor type has been configured for Recip-0 through 3.

SETPOINTS – *Auxiliaries - Analog Inputs - Page 1*

08:36:01
Apr 30 2008

Auxiliary Analog Input Safeties
Page 1

		Low		High	
		Setpoint	Delay	Setpoint	Delay
Auxiliary Analog 1	Warning	30.0 Hg	0 SEC	30.0 Hg	0 SEC
When Running	Shutdown	30.0 Hg	0 SEC	30.0 Hg	0 SEC
Auxiliary Analog 2	Warning	30.0 Hg	0 SEC	30.0 Hg	0 SEC
Always	Shutdown	30.0 Hg	0 SEC	30.0 Hg	0 SEC
Auxiliary Analog 3	Warning	30.0 Hg	0 SEC	30.0 Hg	0 SEC
Disabled	Shutdown	30.0 Hg	0 SEC	30.0 Hg	0 SEC
Auxiliary Analog 4	Warning	30.0 Hg	0 SEC	30.0 Hg	0 SEC
Disabled	Shutdown	30.0 Hg	0 SEC	30.0 Hg	0 SEC
Auxiliary Analog 5	Warning	30.0 Hg	0 SEC	30.0 Hg	0 SEC
Disabled	Shutdown	30.0 Hg	0 SEC	30.0 Hg	0 SEC

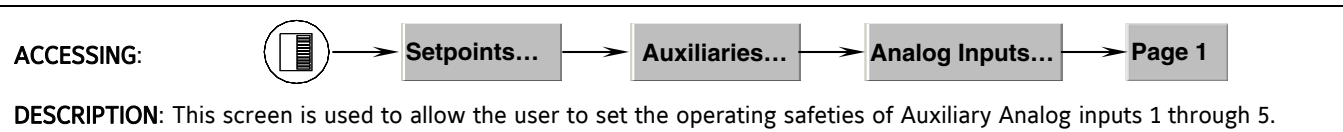

Drop down menu boxes are provided for the following:

Auxiliary Analogs 1 through 5:

- **Disabled** – The auxiliary channel will not be monitored for warnings or shutdowns.
- **When Running** – The auxiliary channel will be monitored for warning and shutdown occurrences only when the compressor is in the run state.
- **Always** – The auxiliary channel will be monitored for warning and shutdown occurrences at all times (Running or not).

The following setpoints are provided for each Auxiliary Analog channel:

[Low Warning Setpoint] – This setpoint specifies the *Low Warning* alarm threshold. In the event that the associated auxiliary analog input falls below this value for a period of time exceeding the *Low Warning Delay*, an Auxiliary Low Warning will be issued.

[Low Warning Delay] – This setpoint specifies the period of time that the associated auxiliary analog input must remain below the *Low Warning Setpoint* before an Auxiliary Low Warning will be issued.

[Low Shutdown Setpoint] – This setpoint specifies the *Low Shutdown* threshold. In the event that the associated auxiliary analog input falls below this value for a period of time exceeding the *Low Shutdown*

Delay, an Auxiliary Low Shutdown will be issued, and the compressor will stop.

[Low Shutdown Delay] – This setpoint specifies the period of time that the associated auxiliary analog input must remain below the *Low Shutdown Setpoint* before an Auxiliary Shutdown will be issued.

[High Warning Setpoint] – This setpoint specifies the *High Warning* threshold. In the event that the associated auxiliary analog input exceeds this value for a period of time exceeding the *High Warning Delay*, an Auxiliary High Warning will be issued.

[High Warning Delay] – This setpoint specifies the period of time that the associated auxiliary analog input must remain above the *High Warning Setpoint* before an Auxiliary High Warning will be issued.

[High Shutdown Setpoint] – This setpoint specifies the *High Shutdown* alarm threshold. In the event that the associated auxiliary analog input exceeds this value for a period of time exceeding the *High Shutdown Delay*, an Auxiliary High Shutdown will be issued, and the compressor will stop.

[High Shutdown Delay] – This setpoint specifies the period of time that the associated auxiliary analog input must remain above the *High Shutdown Setpoint* before an Auxiliary Shutdown will be issued.

NOTE: If you wish to bypass the warnings and utilize only the shutdown feature, then set all warning values outside of the shutdown values.

SETPOINTS – Auxiliaries- Analog Inputs – Page 2

08:42:47
Apr 30 2008

Auxiliary Analog Input Safeties
Page 2

		Low		High	
		Setpoint	Delay	Setpoint	Delay
Auxiliary Analog 6 Disabled	Warning Shutdown	30.0 Hg 30.0 Hg	0 SEC 0 SEC	30.0 Hg 30.0 Hg	0 SEC 0 SEC
Auxiliary Analog 7 Disabled	Warning Shutdown	30.0 Hg 30.0 Hg	0 SEC 0 SEC	30.0 Hg 30.0 Hg	0 SEC 0 SEC
Auxiliary Analog 8 Disabled	Warning Shutdown	30.0 Hg 30.0 Hg	0 SEC 0 SEC	30.0 Hg 30.0 Hg	0 SEC 0 SEC
Auxiliary Analog 9 Disabled	Warning Shutdown	30.0 Hg 30.0 Hg	0 SEC 0 SEC	30.0 Hg 30.0 Hg	0 SEC 0 SEC
Auxiliary Analog 10 Disabled	Warning Shutdown	30.0 Hg 30.0 Hg	0 SEC 0 SEC	30.0 Hg 30.0 Hg	0 SEC 0 SEC

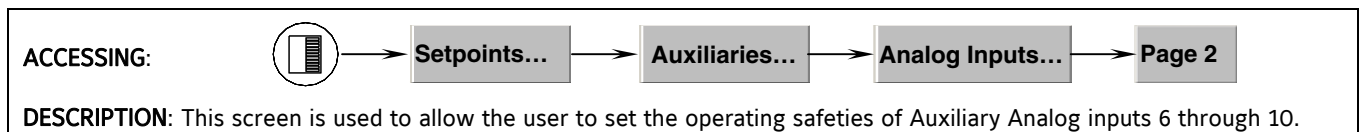

Drop down menu boxes are provided for the following:

Auxiliary Analogs 6 through 10:

- **Disabled** – The auxiliary channel will not be monitored for warnings or shutdowns.
- **When Running** – The auxiliary channel will be monitored for warning and shutdown occurrences only when the compressor is in the run state.
- **Always** – The auxiliary channel will be monitored for warning and shutdown occurrences at all times (Running or not).

The following setpoints are provided for each Auxiliary Analog channel:

[Low Warning Setpoint] – This setpoint specifies the *Low Warning* alarm threshold. In the event that the associated auxiliary analog input falls below this value for a period of time exceeding the *Low Warning Delay*, an Auxiliary Low Warning will be issued.

[Low Warning Delay] – This setpoint specifies the period of time that the associated auxiliary analog input must remain below the *Low Warning Setpoint* before an Auxiliary Low Warning will be issued.

[Low Shutdown Setpoint] – This setpoint specifies the *Low Shutdown* threshold. In the event that the associated auxiliary analog input falls below this value for a period of time exceeding the *Low Shutdown*

Delay, an Auxiliary Low Shutdown will be issued, and the compressor will stop.

[Low Shutdown Delay] – This setpoint specifies the period of time that the associated auxiliary analog input must remain below the *Low Shutdown Setpoint* before an Auxiliary Shutdown will be issued.

[High Warning Setpoint] – This setpoint specifies the *High Warning* threshold. In the event that the associated auxiliary analog input exceeds this value for a period of time exceeding the *High Warning Delay*, an Auxiliary High Warning will be issued.

[High Warning Delay] – This setpoint specifies the period of time that the associated auxiliary analog input must remain above the *High Warning Setpoint* before an Auxiliary High Warning will be issued.

[High Shutdown Setpoint] – This setpoint specifies the *High Shutdown* alarm threshold. In the event that the associated auxiliary analog input exceeds this value for a period of time exceeding the *High Shutdown Delay*, an Auxiliary High Shutdown will be issued, and the compressor will stop.

[High Shutdown Delay] – This setpoint specifies the period of time that the associated auxiliary analog input must remain above the *High Shutdown Setpoint* before an Auxiliary Shutdown will be issued.

NOTE: If you wish to bypass the warnings and utilize only the shutdown feature, then set all warning values outside of the shutdown values.

SETPOINTS – Auxiliaries – Digital Inputs

08:45:06
Apr 30 2008 **Digital Input Configuration**

Name	Device Source	I/O Channel	Activity	Delay
Auxiliary Input 1	Digital Board1	17	Disabled	0 SEC
Auxiliary Input 2	Digital Board1	18	Disabled	0 SEC
Auxiliary Input 3	Digital Board2	9	Disabled	0 SEC
Auxiliary Input 4	Digital Board2	10	Disabled	0 SEC
Auxiliary Input 5	Digital Board2	11	Disabled	0 SEC
Auxiliary Input 6	Digital Board2	12	Disabled	0 SEC
Auxiliary Input 7	Digital Board2	13	Disabled	0 SEC
Auxiliary Input 8	Digital Board2	14	Disabled	0 SEC

ACCESSING: 

DESCRIPTION: This screen is used to view and set the Auxiliary Digital Input values. It is also used to custom name each of the Auxiliary Digital channels.

This screen can be used to custom name each of the Auxiliary Analog channels as well as performing calibration. To change a name:

- **Locally, at the Panel** – Use the [TAB] button to scroll down the screen to the text line that you wish to change. Press the [^] (up arrow) button. This will cause the screen to be replaced with an Alpha/Numeric key pad entry screen. Refer to the section in this manual entitled *MISCELLANEOUS SCREENS - Alpha* for additional information entering text using this screen.
- **Using a Web browser** – Simply click on the box that contains the name (at the left side of the screen), and type a new name into the box, then click [Submit].

Use this screen to setup an Auxiliary Digital Input that is to be used to generate a warning or a shutdown whenever the associated input is not energized (off). As an example from the screen shown above:

If Auxiliary Input 1 is set to *Shutdown When Running*, and the *Delay* is set to 10 seconds, then whenever the device that is physically attached to I/O Channel 17 (Digital Board 1) becomes de-energized (turns off) AND the unit is *Running*, then the delay timer will start to count down. When the Delay times out, a shutdown message is issued (*Auxiliary Input 1 Shutdown*), and the unit will stop running.

A drop down menu box is provided for each of the eight possible Auxiliary Inputs:

[Activity]

- **Disabled** – The device will not be monitored for warnings or shutdowns.
- **Shutdown When Starting/Running** – The device will be monitored for shutdown occurrences only while the compressor is transitioning from the starting state to the running state.
- **Shutdown When Running** – The device will be monitored for shutdown occurrences only after the compressor enters the running state.
- **Shutdown Always** – The device will be monitored for shutdown occurrences all of the time.
- **Warning When Starting/Running** – The device will be monitored for warning occurrences only while the compressor is transitioning from the starting state to the running state.
- **Warning When Running** – The device will be monitored for warning occurrences only after the compressor enters the running state.
- **Warning Always** – The device will be monitored for warning occurrences all of the time.

[Delay] – This value specifies the duration that the digital signal must remain off before a warning or shutdown is issued.

SETPOINTS – Auxiliaries – Digital Outputs

08:48:01
Apr 30 2008

Digital Output Configuration

Output Status	Analog Channel	On When	Off When	Control When
A Off	Capacity Slide Position	0.0 %	0.0 %	Disabled
B Off	Capacity Slide Position	0.0 %	0.0 %	Disabled
C Off	Capacity Slide Position	0.0 %	0.0 %	Disabled
D Off	Capacity Slide Position	0.0 %	0.0 %	Disabled
E Off	Capacity Slide Position	0.0 %	0.0 %	Disabled
F Off	Capacity Slide Position	0.0 %	0.0 %	Disabled
G Off	Capacity Slide Position	0.0 %	0.0 %	Disabled
H Off	Capacity Slide Position	0.0 %	0.0 %	Disabled
I Off	Capacity Slide Position	0.0 %	0.0 %	Disabled
J Off	Capacity Slide Position	0.0 %	0.0 %	Disabled

Output	Device Source	IO Channel
A	Digital Board2	7
B	Digital Board2	8
C	Digital Board2	18
D	None	0
E	None	0
F	None	0
G	None	0
H	None	0
I	None	0
J	None	0

ACCESSING: **DESCRIPTION:** This screen allows the user to set operating parameters of the Digital Outputs.

Use this screen to setup and control an *Auxiliary Digital Output* based upon the signal from an Analog Input. The graphic shown below illustrates one scenario in which an analog Temperature input is used to drive a digital output. When the temperature exceeds the **On When** value of 75°, the output will be energized. It will remain in this state until the analog input falls below the **Off When** value of 73°. This state will persist until the input again exceeds the **On When** value. The resulting temperature control would resemble the following sine wave:

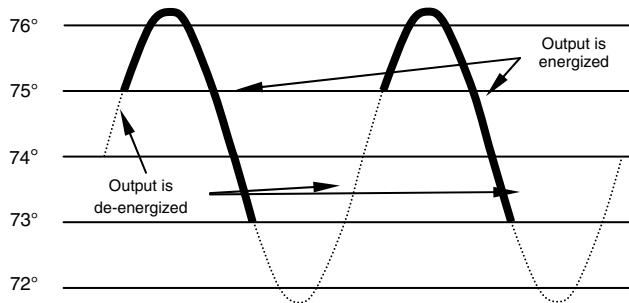

The bottom half of this screen shows the available Digital Outputs along with their Device Source and I/O Channels.

A drop down menu box is provided to select a channel to control from:

[Analog Channel] –

- Capacity Slide Position
- Volume Slide Position
- Suction Pressure

- Discharge Pressure
- Compressor Oil Pressure
- Main Oil Injection Pressure
- Economizer Pressure
- Filter Pressure
- Intermediate Pressure
- Balance Piston Pressure
- System Discharge Pressure
- Suction Temperature
- Discharge Temperature
- Compressor Oil Temperature
- Oil Separator Temperature
- Process/Brine Temperature Leaving
- Process/Brine Temperature Entering
- Motor Current
- RPM
- Auxiliary Analog 1 - 10
- EZ Cool Feedback %
- Auxiliary Analog 12 - 20
- Manifold Pressure
- Compressor Vibration – Suction
- Compressor Vibration – Discharge
- Motor Vibration – Shaft Side
- Motor Vibration – Opposite Shaft Side
- Motor Temperature – Shaft Side
- Motor Temperature – Opposite Shaft Side
- Motor Stator #1 - #3

[On/Off When] – When operating in the (>) mode, the digital output will be de-energized when the analog

signal falls below the *Off When* value, and will remain off until the input rises above the *On When* value. Similarly, when operating in the (-) mode, the digital output will be de-energized when the input signal exceeds the *Off When* value and re-energized when the analog signal falls below *On When* value.

[Control When] -

- **Disabled** - The output will be disabled.
- **Running** - The output is controlled while the compressor is running.
- **Always** - The output is controlled always.

SETPOINTS - Panel

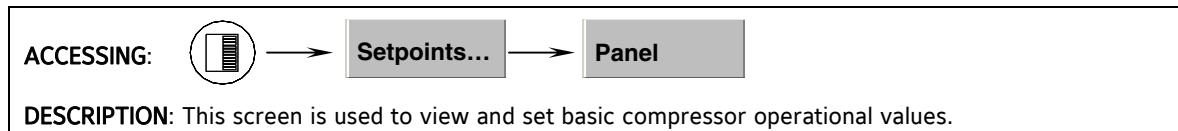
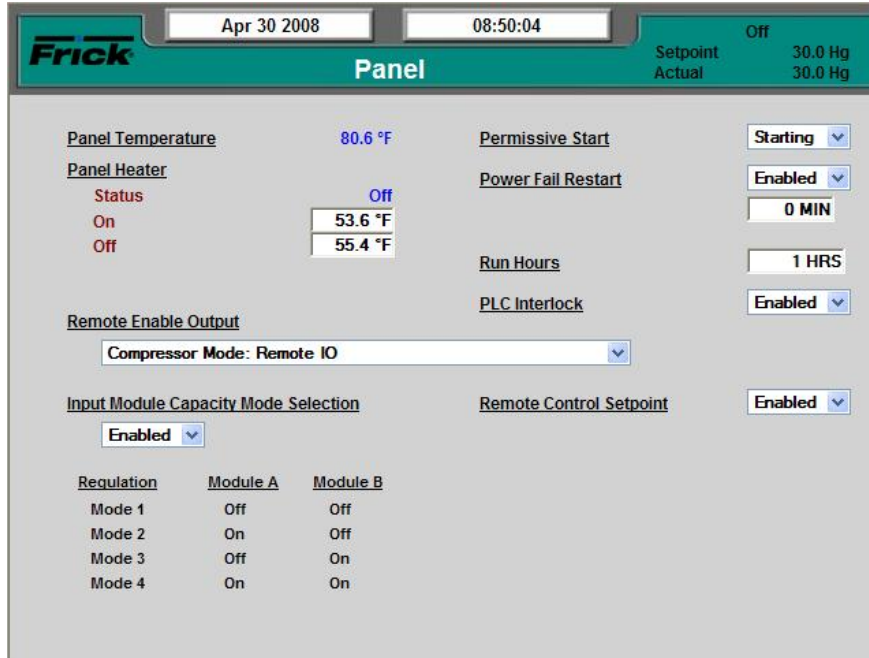

The following information is provided:

Panel Temperature - The main processor board is equipped with a temperature sensor. The panel has an operational temperature range that should be maintained. The operational temperature range is documented in the specifications document.

Panel Heater - A heating pad is mounted in the enclosure to keep the internal panel temperature elevated enough to keep the liquid crystal material of the display from freezing. A *Status* message shows the current state of the Panel Heater:

- **Off** - Panel Heater is Off.
- **On** - Panel Heater is On

Whether the Panel Heater is On or Off is determined by the setting of the following two setpoints:

- **On** - If the sensor on the main processor board detects that the temperature is less than or equal to this setpoint, the Panel Heater output is turned on.
- **Off** - If the sensor on the main processor board detects that the temperature is greater than or equal to this setpoint, the Panel Heater output is turned off.

[Remote Enable Output] - The output for channel 2, analog board 2 (Remote Enable) will be energized when the Compressor Mode has been set for Remote operation, and one of the following parameters have been selected:

- **Disabled** - This feature is disabled.
- **Compressor Mode: Remote I/O**

- **Compressor and Capacity Modes: Remote I/O**
- **Compressor Mode: Remote I/O and Capacity Mode: Remote 4-20**

The following pull-down boxes are provided:

Permissive Start – The input used for this feature is Module 17 of digital board 2. This feature has three possible states:

- **Disabled** – The feature is disabled
- **Starting** – This input needs to be energized only to start the compressor.
- **Always** – This input must be energized to start the compressor. If the compressor is running, and this input is de-energized, the compressor is stopped.

Power Fail Restart – The setting of this feature determines whether or not the compressor will automatically attempt to restart itself after a power failure has occurred.

- **Disabled** – This feature is disabled.
- **Enabled** – This feature is enabled.

Run Hours – The number of hours that the compressor has run is shown here.

PLC Interlock – When enabled, this will determine Slide Valve control. If an input module has been installed into position #1 of Analog Board 2, it will be used to determine PLC Control. If the input signal is lost, the mode is switched to Automatic. The input must be energized before going into Remote.

[Input Module Capacity Mode Selection] – This provides for selecting the Capacity Control via the two input modules rather than the keypad or communications port. This feature has the following possible states:

- **Disabled** – This feature is disabled.
- **Enabled** – This feature is enabled.

Remote Control Setpoint – This provides for using the Remote Control Setpoint analog input (channel 12) for Capacity Control of compressors. A pull down box is provided that changes between the following selections:

- **Disabled** – This feature is disabled.
- **Enabled** – This feature is enabled.

CALIBRATION - Pressure

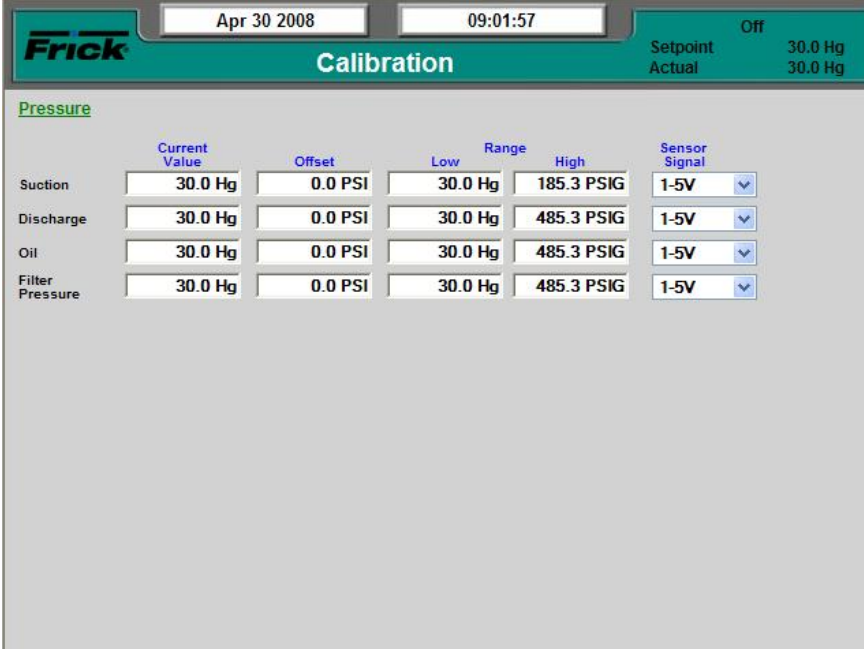

	Current Value	Offset	Low	Range High	Sensor Signal
Suction	30.0 Hg	0.0 PSI	30.0 Hg	185.3 PSIG	1-5V
Discharge	30.0 Hg	0.0 PSI	30.0 Hg	485.3 PSIG	1-5V
Oil	30.0 Hg	0.0 PSI	30.0 Hg	485.3 PSIG	1-5V
Filter Pressure	30.0 Hg	0.0 PSI	30.0 Hg	485.3 PSIG	1-5V

ACCESSING:  → **Calibration...** → **Pressure**

DESCRIPTION: This screen is used to view and set the pressure calibration values.

This screen should be used anytime a pressure sensor is found to be out of calibration. The recommended practice for adjusting the calibration reading is to first determine which sensor(s) need to be calibrated. Once this is determined, you must know the actual reading that the sensor should be showing, This can be accomplished by comparing the displayed reading shown here, with the actual value using a separate measurement device, such as a Digital Volt Meter, or temperature probe, etc. Determine the difference between what the screen reading for the sensor is, and what the reading of the separate device shows. As an example, assume that the Suction Pressure on this screen reads 135 PSIG, but a separate device is showing a reading of 142 PSIG. Highlight the offset box for Suction Pressure, and enter the value of -7. The new reading will now read 135, and should match your separate reading.

The following fields are provided:

Pressure - The following sensor values are displayed along with the unit of measure:

Suction - This value is measured at the compressor inlet.

Discharge - This value is measured at the compressor outlet.

Oil - This value is measured prior to entering the compressor.

Filter Pressure - This value is measured prior to entering the filter.

CALIBRATION - Temperature

	Current Value	Offset	Range Low	Range High	Sensor Signal
Suction	92.1 °F	-9.9 °F	-459.4 °F	463.1 °F	0-5V
Discharge	-459.4 °F	230.6 °F	-459.4 °F	463.1 °F	1-5V
Oil	-438.5 °F	-0.0 °F	-459.4 °F	463.1 °F	0-10V
Separator	-459.4 °F	-0.0 °F			ICTD

Panel	80.6 °F	19.8 °F
-------	---------	---------

ACCESSING:  → Calibration... → Temperature

DESCRIPTION: This screen is used to view and set the temperature calibration values.

This screen should be used anytime a temperature sensor is found to be out of calibration. The recommended practice for adjusting the calibration reading is to first determine which sensor(s) need to be calibrated. Once this is determined, you must know the actual reading that the sensor should be showing, This can be accomplished by comparing the displayed reading shown here, with the actual value using a separate measurement device, such as a Digital Volt Meter, or temperature probe, etc. Determine the difference between what the screen reading for the sensor is, and what the reading of the separate device shows. As an example, assume that the Suction Temperature on this screen reads 120° F, but a separate device is showing a reading of 123° F. Highlight the setpoint box for Suction Temperature, and enter the value of 123. The new reading will now read 123, and should match your separate reading.

The following fields are provided:

Temperature - The following sensor values are displayed along with the unit of measure:

Suction - This value is measured at the compressor inlet.

Discharge - This value is measured at the compressor outlet.

Oil - This value is measured prior to entering the compressor.

Separator - Oil Separator Temperature value is displayed.

Panel - This reading is measured on the Quantum™ LX controller itself, and shows the actual board temperature value.

CALIBRATION - Capacity/Volume

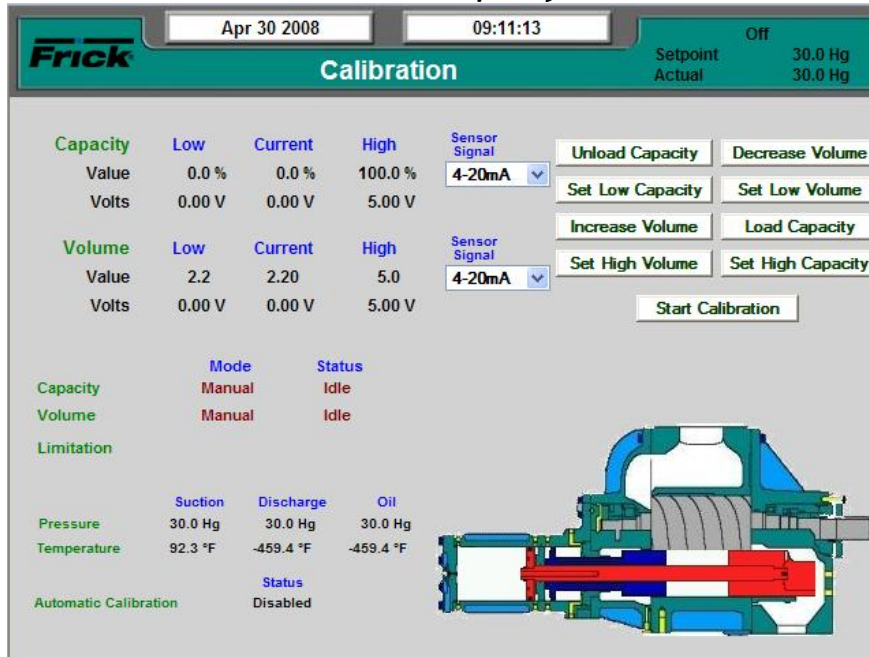

ACCESSING:



Calibration...

Capacity/Volume

DESCRIPTION: This screen is used to view and set the capacity and volume calibration values.

The following drop-down menus are provided:

[Sensor Signal] – Select the type of sensor for both Capacity and Volume, from the choices provided.

- None
- 0-5 V
- 1-5 V
- 4-20mA
- Pot.
- ICTD
- RTD
- CT
- RPM
- Vibration
- 0-10 V
- +/-5 V

There are a total of nine buttons provided. The first group of eight allows for manually calibrating the Slide Valve and Slide Stop. These buttons are:

- [Unload Capacity]
- [Decrease Volume]
- [Set Low Capacity]
- [Set Low Volume]
- [Increase Volume]
- [Load Capacity]
- [Set High Volume]
- [Set High Capacity]

The ninth button allows for automatic calibration of the Slide Valve and Slide Stop. Pressing this button will automatically perform all 8 steps of the manual calibration:

- [Start Calibration]

CALIBRATION - Motor/Miscellaneous

ACCESSING:  → **Calibration...** → **Miscellaneous**

DESCRIPTION: This screen is used to view and set miscellaneous calibration values that are not shown on other screens.

This screen should be used anytime a sensor is found to be out of calibration. The recommended practice for adjusting the calibration reading is to first determine which sensor(s) need to be calibrated. Once this is determined, you must know the actual reading that the sensor should be showing. This can be accomplished by comparing the displayed reading shown here, with the actual value using a separate measurement device, such as a Digital Volt Meter, or temperature probe, etc. Determine the difference between what the screen reading for the sensor is, and what the reading of the separate device shows. As an example, assume that the Suction Temperature on this screen reads 120° F, but a separate device is showing a reading of 123° F. Highlight the setpoint box for Suction Temperature, and enter the value of 123. The new reading will now read 123, and should match your separate reading.

The following fields are provided:

Miscellaneous - The following sensor values are displayed along with the unit of measure:

Motor Amps - This value is measured directly at the Channel 16 input of analog board 1.

Remote Control Setpoint

CALIBRATION – PHD Monitoring

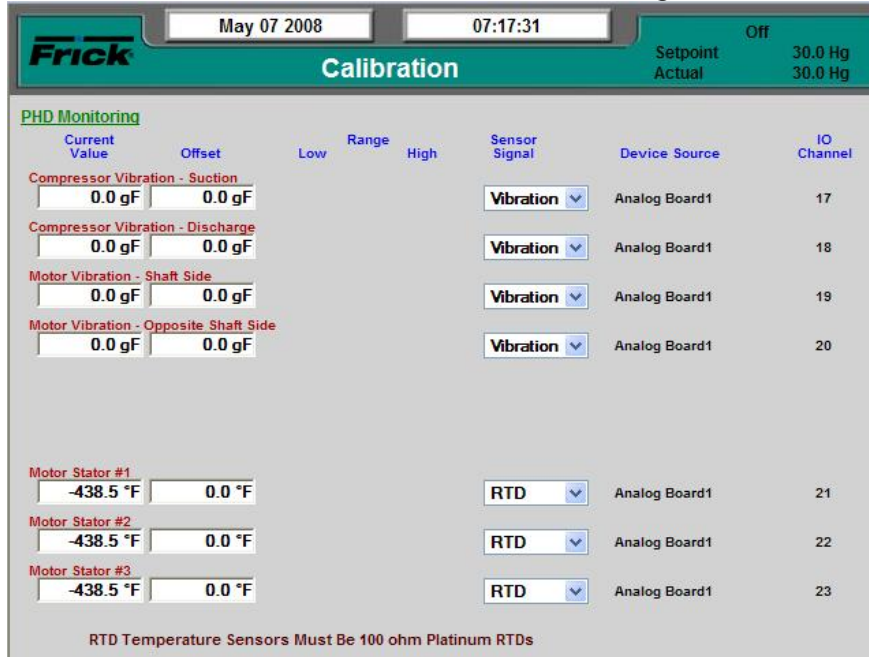

PHD Monitoring	Current Value	Offset	Low	High	Sensor Signal	Device Source	IO Channel
Compressor Vibration - Suction	0.0 gF	0.0 gF			Vibration	Analog Board1	17
Compressor Vibration - Discharge	0.0 gF	0.0 gF			Vibration	Analog Board1	18
Motor Vibration - Shaft Side	0.0 gF	0.0 gF			Vibration	Analog Board1	19
Motor Vibration - Opposite Shaft Side	0.0 gF	0.0 gF			Vibration	Analog Board1	20
Motor Stator #1	-438.5 °F	0.0 °F			RTD	Analog Board1	21
Motor Stator #2	-438.5 °F	0.0 °F			RTD	Analog Board1	22
Motor Stator #3	-438.5 °F	0.0 °F			RTD	Analog Board1	23

RTD Temperature Sensors Must Be 100 ohm Platinum RTDs

ACCESSING: 

DESCRIPTION: This screen is used to view and set PHD calibration values.

The following drop-down and setpoint boxes are provided:

Compressor Vibration – (Suction, Discharge)

[Current Value] – The actual amount of vibration that is being sensed (taking into account the offset).

[Offset] – A value entered here will allow the user to compensate for calibration issues with a sensor.

[Sensor Signal]

- None
- 0-5V
- 1-5V
- 4-20mA
- Pot.
- ICTD
- RTD
- CT
- RPM
- Vibration
- 0-10V
- +/-5V

Motor Vibration – (Shaft Side, Opposite Shaft Side)

[Current Value] – The actual amount of vibration that is being sensed (taking into account the offset).

[Offset] – A value entered here will allow the user to compensate for calibration issues with a sensor.

[Sensor Signal]

- None

- 0-5V
- 1-5V
- 4-20mA
- Pot.
- ICTD
- RTD
- CT
- RPM
- Vibration
- 0-10V
- +/-5V

Motor Stator – (1, 2 and 3)

[Current Value] – The actual amount of vibration that is being sensed (taking into account the offset).

[Offset] – A value entered here will allow the user to compensate for calibration issues with a sensor.

[Sensor Signal]

- None
- 0-5V
- 1-5V
- 4-20mA
- Pot.
- ICTD
- RTD
- CT
- RPM
- Vibration
- 0-10V
- +/-5V

CALIBRATION – Analog Outputs – Retransmitting Outputs

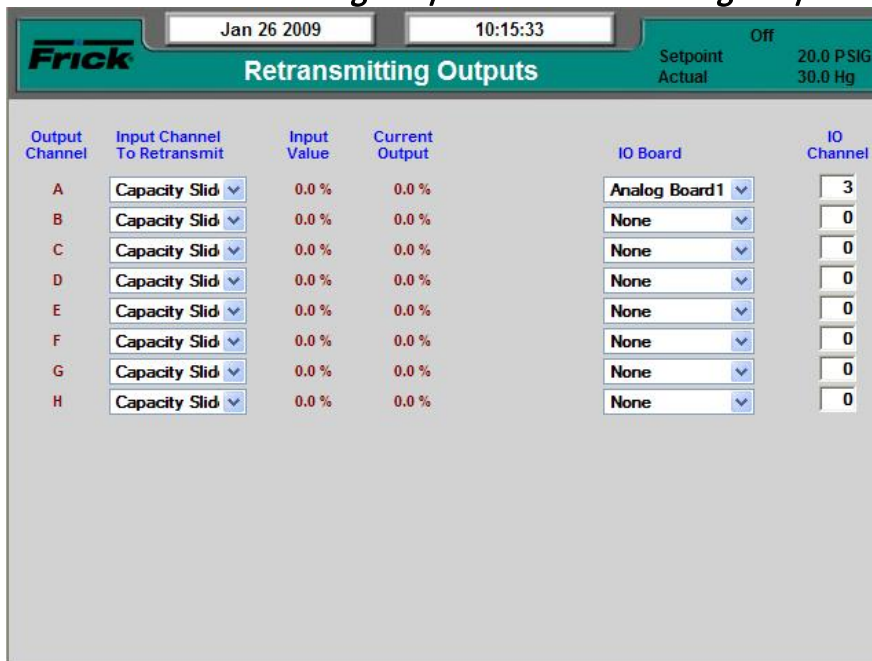

Output Channel	Input Channel To Retransmit	Input Value	Current Output	IO Board	IO Channel
A	Capacity Slid	0.0 %	0.0 %	Analog Board 1	3
B	Capacity Slid	0.0 %	0.0 %	None	0
C	Capacity Slid	0.0 %	0.0 %	None	0
D	Capacity Slid	0.0 %	0.0 %	None	0
E	Capacity Slid	0.0 %	0.0 %	None	0
F	Capacity Slid	0.0 %	0.0 %	None	0
G	Capacity Slid	0.0 %	0.0 %	None	0
H	Capacity Slid	0.0 %	0.0 %	None	0

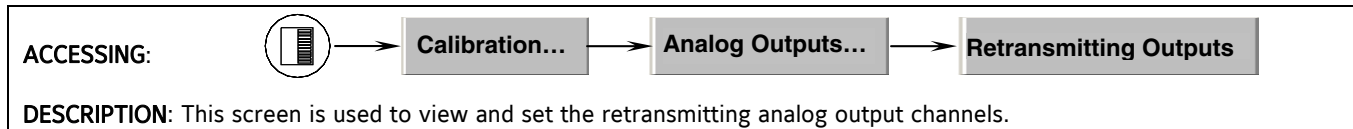

The following fields are provided:

Input Channel to Retransmit - Use this pull down menu for each channel to select the analog signal that you would like to retransmit:

- Capacity Slide Position
- Volume Slide Position
- Suction Pressure
- Discharge Pressure
- Compressor Oil Pressure
- Main Oil Injection Pressure
- Economizer Pressure
- Filter Pressure
- Intermediate Pressure
- Balance Piston Pressure
- System Discharge Pressure
- Suction Temperature
- Discharge Temperature
- Compressor Oil Temperature
- Oil Separator Temperature
- Process/Brine Temperature Leaving
- Process/Brine Temperature Entering
- Motor Current
- RPM
- Auxiliary Analog 1 - 10
- EZ Cool Feedback %

- Auxiliary Analog 12 - 20
- Manifold Pressure
- Compressor Vibration - Suction
- Compressor Vibration - Discharge
- Motor Vibration - Shaft Side
- Motor Vibration - Opposite Shaft Side
- Motor Temperature - Shaft Side
- Motor Temperature - Opposite Shaft Side
- Motor Stator #1
- Motor Stator #2
- Motor Stator #3

IO Board - Use this pull down menu to select the source of the retransmit signal:

- None
- Analog Board 1
- Analog Board 2

Device Channel - Use this pull down menu to select the source channel of the Device Source (Analog Board 1 or 2).

CALIBRATION - Analog Outputs

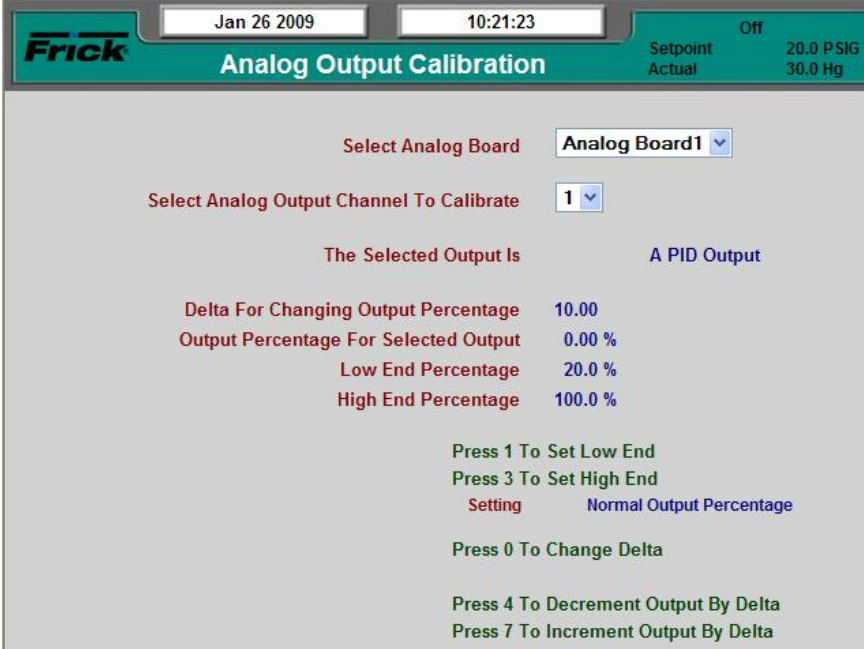

ACCESSING:



Calibration...

Analog Outputs...

Output Calibration

DESCRIPTION: This screen is used to calibrate individual analog outputs.

Use this screen if an analog output signal (channel) requires calibration.

The Quantum's analog outputs have a range of approximately 0 to 25mA, but most devices that are controlled by the Quantum™ LX require a signal that varies between 4 and 20mA. To restrict the analog outputs to the proper values, each of the outputs must be calibrated before they can be used. Every output channel has a *Low End* and a *High End* value that are used for calibration. Both values can be set from 0% to 100%. The output channel's maximum value is represented by 100% and its minimum value is represented by 0%. To calibrate the channel, the *High End* percentage is decreased until the maximum output for the channel is limited to 20mA. Also, the *Low End* percentage is increased until the minimum output for the channel is 4mA.

Below is a step by step procedure for calibrating one analog output.

1. Configure the analog output channel for its intended use, i.e., if the channel is to be used for PID control, enter the Device Source and Device Channel of the selected analog output channel under one of the PID columns on the PID Setup page.
2. Set up a meter to read the channel's output value in milliamps.
3. Go to the Analog Output Calibration page.
4. Select the Analog Board and the Channel Number for the output that is being calibrated.
5. After the Analog Board and Channel Number have been selected, the channel's function will be displayed below the Channel Number. If "Not Configured" is shown here instead, the channel has not yet been assign a control function. Return to step 1 and setup the channel for the control task it is to perform.
6. Press the [#1] key (Set Low End) and the value shown on the meter should go to the channel's low end value.
7. Check that the "Delta For Changing Output Percentage" value is 10.00. If not, press the [#0] key (Change Delta) until it is displayed as 10.00.
8. If the channel's output is greater than 4mA press the [#4] key (Decrement Output by Delta). If the channel's output is less than 4mA, press the [#7] key (Increment Output by Delta). Use these keys to find the output value closest to 4mA.
9. Press the [#0] key (Change Delta) once to decrease the "Delta For Changing Output Percentage" value to 1.00.
10. Use the [#7] and [#4] keys to again find the value closest to 4mA.
11. Repeat steps 9 and 10 for Delta values of 0.1 and 0.01 to bring the output value as close as possible to 4mA.

12. Press the [#3] key (Set High End) and the value shown on the meter should go to the channel's high end value.
 13. Check that the "Delta For Changing Output Percentage" value is 10.00. If it is not, press the [#0] key (Change Delta) until it is displayed as 10.00.
 14. If the channel's output is greater than 20mA press the [#4] key (Decrement Output by Delta). If the channel's output is less than 20mA, press the [#7] key (Increment Output by Delta). Use these keys to find the output value closest to 20mA.
 15. Press the [#0] key (Change Delta) once to decrease the "Delta For Changing Output Percentage" value to 1.00.
 16. Use the [#7] and [#4] keys to again find the value closest to 20mA.
 17. Repeat steps 15 and 16 for Delta values of 0.1 and 0.01 to bring the output value as close as possible to 20mA.
- The analog output channel will return to its control task either when another output channel is selected for calibration or when the user goes to another screen.

CALIBRATION - Auxiliary Analogs - Page 1

Frick		May 07 2008	07:31:50	Off	Setpoint 30.0 Hg
Calibration		Actual 30.0 Hg			
Auxiliary Analogs	Page 1	Current Value	Offset	Low	Range High
Auxiliary Analog 1		30.0 Hg	0.0 PSI	30.0 Hg	485.3 PSIG
Auxiliary Analog 2		30.0 Hg	0.0 PSI	30.0 Hg	485.3 PSIG
Auxiliary Analog 3		30.0 Hg	0.0 PSI	30.0 Hg	485.3 PSIG
Auxiliary Analog 4		30.0 Hg	0.0 PSI	30.0 Hg	485.3 PSIG
Auxiliary Analog 5		30.0 Hg	0.0 PSI	30.0 Hg	485.3 PSIG
Auxiliary Analog 6		30.0 Hg	0.0 PSI	30.0 Hg	485.3 PSIG
Auxiliary Analog 7		30.0 Hg	0.0 PSI	30.0 Hg	485.3 PSIG
Auxiliary Analog 8		30.0 Hg	0.0 PSI	30.0 Hg	485.3 PSIG
Auxiliary Analog 9		30.0 Hg	0.0 PSI	30.0 Hg	485.3 PSIG
Auxiliary Analog 10		30.0 Hg	0.0 PSI	30.0 Hg	485.3 PSIG
EZ Cool Feedback %		-25.0 %	0.0 %	0.0 %	100.0 %

ACCESSING: 

DESCRIPTION: This screen is used to view and set the Auxiliary Analog calibration values. It is also used to custom name each of the Auxiliary Analog channels.

This screen can be used to custom name each of the Auxiliary Analog channels as well as performing calibration. To change a name:

- **Locally, at the Panel** - Use the [TAB] button to scroll down the screen to the text line that you wish to change. Press the [^] (up arrow) button. This will cause the screen to be replaced with an Alpha/Numeric key pad entry screen. Refer to the section in this manual entitled *MISCELLANEOUS SCREENS - Alpha* for additional information entering text using this screen.
- **Using a Web browser** - Simply click on the box that contains the name (at the left side of the screen), and type a new name into the box (refer

to the section entitled *MISCELLANEOUS SCREENS - Alpha*, then click [Submit].

A dropdown menu box exists for each of the displayed auxiliary readings.

- **[Current Value]** - The actual amount of vibration that is being sensed (taking into account the offset).
- **[Offset]** - A value entered here will allow the user to compensate for calibration issues with a sensor.
- **[Range]**
 - Low
 - High

CALIBRATION – Auxiliary Analogs – Page 2

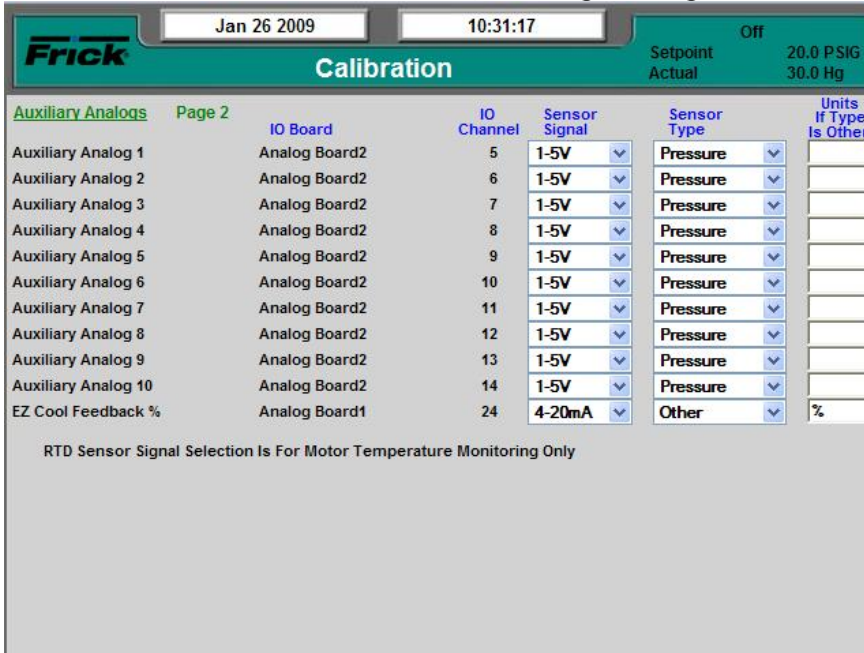

Auxiliary Analogs	IO Board	IO Channel	Sensor Signal	Sensor Type	Units If Type Is Other
Auxiliary Analog 1	Analog Board2	5	1-5V	Pressure	
Auxiliary Analog 2	Analog Board2	6	1-5V	Pressure	
Auxiliary Analog 3	Analog Board2	7	1-5V	Pressure	
Auxiliary Analog 4	Analog Board2	8	1-5V	Pressure	
Auxiliary Analog 5	Analog Board2	9	1-5V	Pressure	
Auxiliary Analog 6	Analog Board2	10	1-5V	Pressure	
Auxiliary Analog 7	Analog Board2	11	1-5V	Pressure	
Auxiliary Analog 8	Analog Board2	12	1-5V	Pressure	
Auxiliary Analog 9	Analog Board2	13	1-5V	Pressure	
Auxiliary Analog 10	Analog Board2	14	1-5V	Pressure	
EZ Cool Feedback %	Analog Board1	24	4-20mA	Other	%

RTD Sensor Signal Selection Is For Motor Temperature Monitoring Only

ACCESSING:



Calibration...

Auxiliaries...

Page 2

DESCRIPTION: This screen is used to view and set the Auxiliary Analog calibration values.

This screen will show any custom named auxiliaries from Page 1 at the left side of the screen. Use this screen to set the Sensor Signal, Sensor Type, and to change the units if set to *Other*.

The following informational areas are provided (cannot be changed from this screen):

Auxiliary Analogs – These are the names given to the each of the Auxiliary Analog channels. They may be show as the original default names, or as names that have been customized (see the preceding page).

IO Board – The data shown here describes on which Analog board the associated sensor is located.

IO Channel – The data shown here describes on which Analog channel of the *Device Source* the associated sensor is located.

A dropdown menu box exists for each of the displayed auxiliary readings:

- **Sensor Signal**
 - None
 - 0-5V
 - 1-5V

- 4-20mA
- Pot. (Potentiometer)
- ICTD
- RTD
- CT
- 0-20mA
- Vibration
- 0-10V
- **Sensor Type**
 - None
 - Pressure
 - Temperature
 - Other
- **Units if Type is Other** – Up to 5 characters may be entered here. To enter alpha-numeric values in this column, refer to the section entitled *Miscellaneous Screens - Alpha*.

CONFIGURATION - Compressor

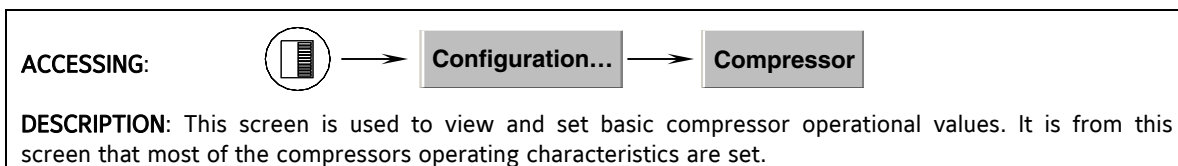

The following drop-down menus are provided:

Date:

[Month]

- 1 - 12

[Day]

- 1 - 31

[Year]

- 2000 - 2050

Time:

[Hour]

- 0 - 23

[Minutes]

- 0 - 59

Miscellaneous:

[Sequencing]

- Disabled
- Enabled

[Condenser]

- Disabled
- Running
- Always

[Screen Saver]

Capacity:

[Mode 1, 2, 3 and 4]

- Disabled
- Enabled

[Channel]

- Capacity Slide Position
- Volume Slide Position
- Suction Pressure
- Discharge Pressure
- Compressor Oil Pressure
- Main Oil Injection Pressure
- Economizer Pressure
- Filter Pressure
- Intermediate Pressure
- Balance Piston Pressure
- System Discharge Pressure
- Suction Temperature
- Discharge Temperature
- Compressor Oil Temperature
- Oil Separator Temperature
- Process/Brine Temperature Leaving
- Process/Brine Temperature Entering
- Remote Control Setpoint
- Motor Current
- RPM
- Auxiliary Analog 1 - 10

- EZ Cool Feedback %
- Auxiliary Analog 12 - 20
- Manifold Pressure
- Remote Capacity Position
- Compressor Vibration - Suction
- Compressor Vibration - Discharge
- Motor Vibration - Shaft Side
- Motor Vibration - Opposite Shaft Side
- Motor Temperature - Shaft Side
- Motor Temperature - Opposite Shaft Side
- Motor Stator #1
- Motor Stator #2
- Motor Stator #3

[Direction]

- Forward
- Reverse

[VFD High And Low PI Control] (This option will only appear if Vyper Drive or VFD has been selected)

- Disabled
- Enabled

Package:

[Compressor]

- RWF
- RWBII
- RXB
- RXF 12-50
- RXF 58-101
- RDB 4-Step
- RDB 3-Step
- GSVII
- GST
- GSB 3-Step
- YLC
- SC
- York S7
- York S5
- Other Manufacturer
- Other Manuf (Mycom)
- Other Manuf (Kobe)
- Recip-0
- Recip-1
- Recip-2
- Recip-3

[Pump]

- No Pump
- Full Time
- Demand
- Shaft With Auxiliary
- Shaft

[Dual Pump]

- Disabled
- Enabled

[Drive]

- Screw Compressor With Constant Electric Drive
- Screw Compressor With VFD Drive
- Screw Compressor With Engine Drive
- Screw Compressor With Turbine Drive
- Screw Compressor With DBS
- Screw Compressor With Vyper (RAM)
- Screw Compressor With Vyper (4-20mA)

[Refrigerant]

- R11
- R113
- R114
- R1150
- R12
- R1270
- R13
- R134a
- R13b1
- R14
- R14b2
- R170
- R218
- R22
- R23
- R290
- R401a
- R402a
- R404a
- R410a
- R50
- R500
- R502
- R503
- R507
- R508
- R508b
- R600
- R600a
- R717
- R718
- R728
- R729
- R744
- R771
- User Defined

[Filter]

- Disabled
- Filter-Oil
- Discharge-Oil
- Discharge-Filter

[PowerPAC]

- No
- Evap And Condenser Temps
- Evap Temps Only
- Evap Leaving Temp Only

CONFIGURATION - *Communications*

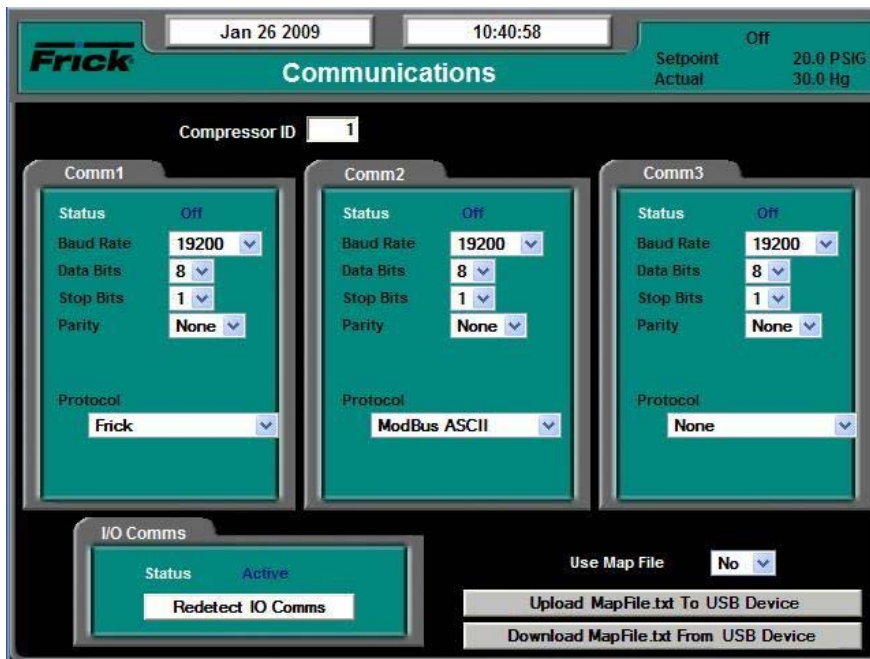

ACCESSING:

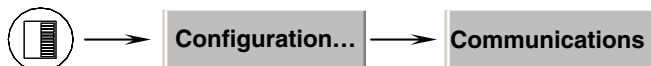

DESCRIPTION: This screen is used to set the compressor ID number, and the parameters for each of the three communications channels, as well as to show the status of the internal I/O board status. NOTE: This screen can also be accessed through Configuration.

The following setpoints are provided:

[Compressor ID] - A number that is used by an external communications application, to converse to individual compressors. On interconnected systems, this number must be unique. Valid values are from 0 - 99.

Comm1 - 3:

Status - Shows the current communications status of the port. The possible messages are:

- **Off** - No communications are currently taking place. NOTE: A delay of 15 seconds or more of inactive communications (time between valid responses) will cause this message to display.
- **Active** - Valid communications are actively occurring.
- **Failed** - An invalid command was received by the port. This could be due to a bad checksum value, a wiring issue, or hardware problem at either the transmitting (host) or receiving (Quantum™ LX) end.

[Baud Rate] - The baud rate defines the speed at which external communications can occur. The higher the baud rate, the faster the communications. A drop down menu is provided to select from the following:

- 1200
- 2400
- 4800
- 9600
- 19200
- 38400
- 57600
- 115200

[Data Bits] - Determines the number of bits in a transmitted data package. A pull down menu is provided to select from the following:

- 7
- 8

[Stop Bits] - A bit(s) which signals the end of a unit of transmission on a serial line. A pull down menu is provided to select from the following:

- 1
- 2

[Parity] - In communications, parity checking refers to the use of *parity bits* to check that data has been transmitted accurately. The parity bit is added to every data unit (typically seven or eight data bits) that are transmitted. The parity bit for each unit is set so that all bytes have either an odd number or an even number of set bits. Parity checking is the most basic form of error detection in communications. A pull down menu is provided to select from the following:

- None
- Even
- Odd

[Protocol] - A protocol is the special set of rules that each end of a communications connection use when they communicate. A pull down menu is provided to select from the following Frick recognized protocols:

- None
- Frick
- ModBus ASCII
- ModBus RTU
- AB DF1 Full Duplex
- AB DF1 Half Duplex
- DBS Motor Starter

I/O Comms - A status indicator is provided to show the current state of the internal communications of the I/O boards. The possible displayed states are:

- **Off** - Loss of, or intermittent communications failures to the internal Quantum™ LX I/O boards.
- **Active** - Indicates that normal I/O communications are occurring.
- **Failed** - Loss of communications, a shutdown message will be generated.

[Redetect IO Comms] - Select this key to detect all connected Analog and Digital boards. If a board has been removed, a communication error shutdown will be issued until this key is selected. Reference the **About** screen to view what has been detected.

[Map File] - Because the addressing scheme between the Quantum™ version 5.0x and earlier software and the Quantum™ LX version 6.0x and later software is not the same, this utility was created. The map file is a conversion utility that can be used to allow a communications application that was previously written by the user under the Quantum™ version 5.0x and earlier to function properly with the LX by redirecting the old addresses to the new LX addresses. A pull down menu is provided to select from the following:

- **No** - Do not use map file, the user is either not going to be using external communications, or they will be writing the communication application based upon the LX addresses.
- **Yes** - The user has an application that was previously written for the Quantum™ version 5.0x or earlier, and they want to utilize the same code for the LX.

Two keys are located at the bottom right hand side of the screen. The following describes their function:

[Upload MapFile.txt to USB Device] - After the user has modified the MapFile.txt file to suit their needs, pressing this key will cause the file to be uploaded from the USB memory back into the Quantum™ LX.

[Download MapFile.txt from Quantum™ LX] - With a USB memory stick installed on the LX, pressing this key will cause the MapFile.txt file to be downloaded from the Quantum™ LX into the USB memory.

CONFIGURATION - Ethernet

ACCESSING:  → **Configuration...** → **Ethernet**

DESCRIPTION: This screen is used to view and set basic Ethernet operational values, as well as all e-mail based operating characteristics. **NOTE:** A valid internet account and connection must be available for this feature to function.

NOTE: User Level 1 or above must be set to access this screen.

The following fields are provided:

IP Data:

[Address Type] - The following drop down menu is provided:

- Fixed (Static)
- DHCP (Dynamic)

This should be set by the network or LAN administrator.

[IP Address] - Four setpoint boxes are provided here. The network or LAN administrator will enter the numerical IP address for this specific Quantum™ LX panel. This setpoint box will be automatically assigned if the address type is set to DHCP.

[Gateway Address] - Four setpoint boxes are provided here. The network or LAN administrator will enter the numerical Gateway address. This setpoint box will be automatically assigned if the address type is set to DHCP.

[Subnet Mask] - Like IP addresses, a subnet mask contains four bytes (32 bits) and is often written using the same "dotted-decimal" notation. A subnet mask neither works like an IP address, nor does it exist independently from them. Instead, subnet masks accompany an IP address and the two values work together. This setpoint box will

be automatically assigned if the address type is set to DHCP.

Applying the subnet mask to an IP address splits the address into two parts, an "extended network address" and a host address.

For a subnet mask to be valid, its leftmost bits must be set to '1'. Conversely, the rightmost bits in a valid subnet mask must be set to '0', not '1'.

All valid subnet masks contain two parts: the left side with all mask bits set to '1' (the extended network portion) and the right side with all bits set to '0' (the host portion).

[Web Server Port] - One setpoint box is provided here. The network or LAN administrator will enter the numerical address for this Web port (80 is typically used).

Email Data

[Email Notification On Alarm or Shutdown] - For the E-mail notification feature to work, it must be enabled (it is disabled as a default). The following drop down menu is provided:

- Disabled
- Enabled

[Local Email Address] - Use this setpoint box to enter a valid E-mail address that messages are sent from.

[Alias Name For Local Email Address] - Enter here a custom name to identify more clearly the

local Email address. When a message is sent to all recipients, this is the name that will appear in the Email *FROM* column.

[Subject] - Enter here a custom subject that you would like to have appear when a message failure is sent. When a message is sent to all recipients, this is the wording that will appear in the Email *SUBJECT* column.

[SMTP Server Name OR IP Address] - SMTP stands for Simple Mail Transfer Protocol. This

should be set by the network or LAN administrator.

[SMTP Server Port Number] - This value is in almost all cases going to be 25. This should be set by the network or LAN administrator.

[Comma-Delimited List of Email Recipients] - This is simply the list of the Email addresses that you would like to have any messages sent to.

Refer to the Communications Manual (090-020 CS) for additional information.

CONFIGURATION - Security

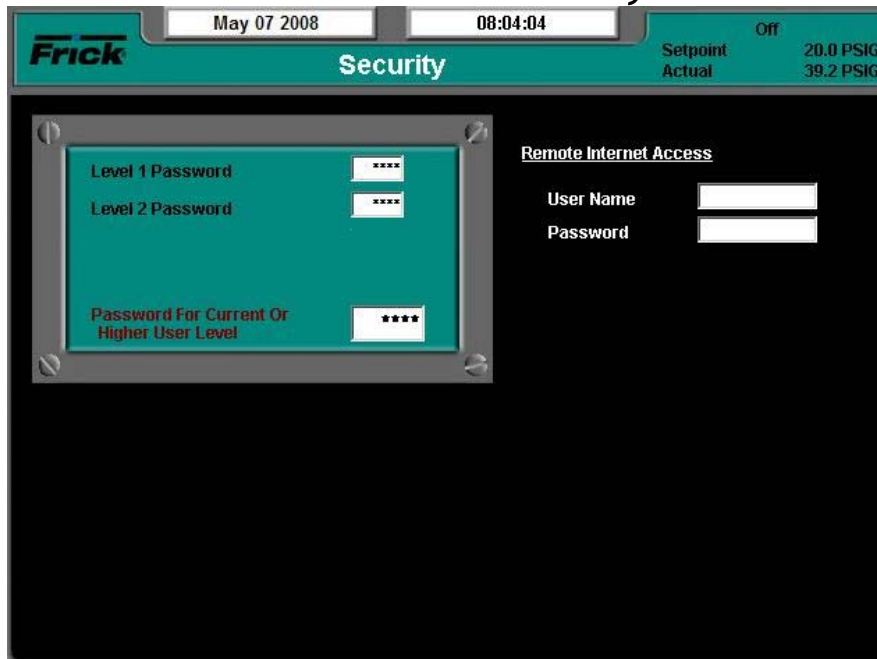

DESCRIPTION: This screen allows the user/supervisor to set the various levels of password protection. The Security screen shown above can only be modified at the Quantum™ LX control panel via the keypad (it is not available through a web browser).

The various levels are:

- **Level 0** - Also known as the BASIC level. This level is not shown on the Security screen, as it is the lowest level of system access, and as such, does not require a password to activate. This is the default level, and provides access to only the very basics of machine operation.
- **Level 1** - Also known as the ADVANCED level. This requires a password to set. Only those users who are authorized with the password may enter this level. It provides greater access than Level 0 (BASIC). The valid entry range is zero (0) to 5000. The factory default value for this password is 10 (ten).
- **Level 2** - Also known as the SERVICE level. This requires a password to set. Only those users who are authorized with the password may enter this level. It

provides greater access than Level 1. The factory default value for this password is 20 (twenty).

To set the password protection for the each level, use the keypad to highlight the box beside the level that you wish to change. Set the level to either zero (0) or one (1) and enter the appropriate password for that level in the next box. The valid range for password entry is -999999 to 999999.

NOTE: It is highly recommended that the supervisor documents this password and stores it in a safe place. If the password is ever forgotten, it can only be corrected by calling the factory.

Remote Internet Access

This feature can be used if you anticipate having users access the compressor panel over the internet, and would like to limit accessibility.

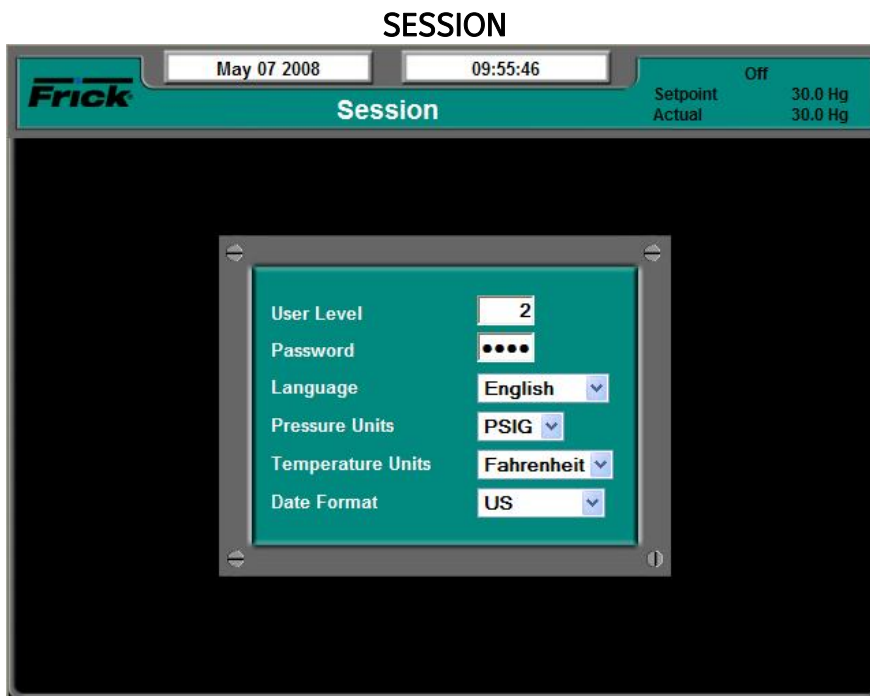

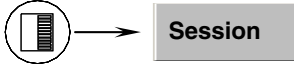
ACCESSING: 

DESCRIPTION: This screen allows the user/supervisor to access the various available user levels. This is also where the user can select the language, pressure units, temperature units and date format. NOTE: This screen is not available when viewing remotely.

The following Setpoints may be changed:

User Level - One of two possible levels may be accessed here. Level one (0) is also referred to as the BASIC level, and requires no password. Level one (1) is referred to as ADVANCED, and requires a password. Level one (2) is referred to as SERVICE, and requires a password.

Password - A password has previously been assigned to each user level by the supervisor. The user must match the password for the particular level that they wish to access. The following factory default passwords have been provided:

- **Level 0** (Basic) - No password required
- **Level 1** (Advanced) - 10
- **Level 2** (Service) - 20

The following pull-down menus have been provided:

Language - You may choose from the following list:

- English
- French
- Chinese
- Portuguese
- Polish
- Traditional Chinese

- Spanish
- Russian
- Italian

Pressure Units - You may choose from the following list:

- Kpaa
- Bar
- BarA
- PSIA
- PSIG/hg

Temperature Units - You may choose from the following list:

- Celsius
- Fahrenheit

Date Format - You may choose from the following list:

- **US** - Month/Day/Year format
- **Europe** - Day/Month/Year format

SERVICE - *Digital*

Digital I/O

<u>Board 1 Channels</u>				<u>Board 2 Channels</u>				<u>Board 3 Channels</u>			
1	Off	13	Off	1		13		1		13	
2	Off	14	Off	2		14		2		14	
3	Off	15	Off	3		15		3		15	
4	Off	16	Off	4		16		4		16	
5	Off	17	Off	5		17		5		17	
6	Off	18	Off	6		18		6		18	
7	Off	19	Off	7		19		7		19	
8	Off	20	Off	8		20		8		20	
9	Off	21	Off	9		21		9		21	
10	Off	22	Off	10		22		10		22	
11	Off	23	Off	11		23		11		23	
12	Off	24	Off	12		24		12		24	

ACCESSING: 

DESCRIPTION: This screen allows the technician to view the status of all installed digital board inputs and outputs. An OFF status indicates that the associated input or output is not energized. An ON status indicates that the associated input or output is energized.

SERVICE - *Analog*

Analog Inputs (data units are Volts DC)

<u>Board 1 Channels</u>				<u>Board 2 Channels</u>				<u>Board 3 Channels</u>			
1	3.08	13	0.36	1		13		1		13	
2	3.34	14	0.37	2		14		2		14	
3	3.11	15	0.40	3		15		3		15	
4	3.12	16	1.11	4		16		4		16	
5	4.95	17	2.56	5				5			
6	1.94	18	2.45	6				6			
7	1.95	19	0.00	7				7			
8	2.31	20	0.00	8				8			
9	2.08	21	0.00	9				9			
10	3.11	22	0.00	10				10			
11	5.00	23	0.00	11				11			
12	0.62	24	0.00	12				12			

Analog Outputs (data units are Volts DC)

<u>Board 1 Channels</u>				<u>Board 2 Channels</u>				<u>Board 3 Channels</u>			
1	0.00	5	0.00	1		5		1		5	
2	0.00	6	0.00	2		6		2		6	
3	0.00	7	0.00	3		7		3		7	
4	0.00	8	0.00	4		8		4		8	

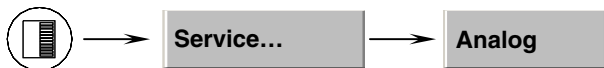
ACCESSING: 

DESCRIPTION: This screen allows the technician to view the status of all installed analog board inputs and outputs. The top section of this screen shows the analog inputs. A value displayed next to each available channel indicates the DC voltage that is present as an input. The lower half of the screen shows the analog outputs. A value displayed next to each available channel indicates the DC voltage that is present as an output.

SERVICE - *ModBus TCP Log*

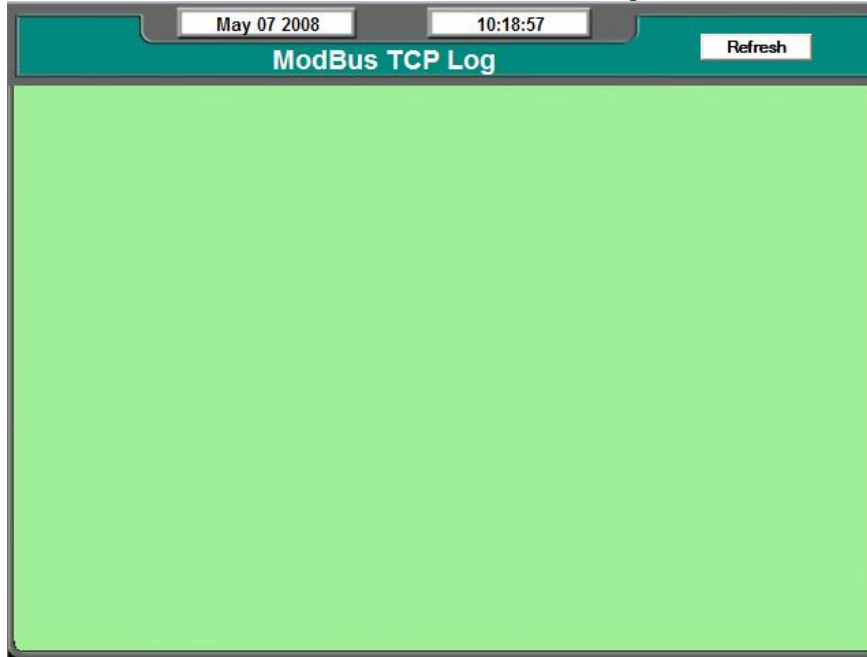

ACCESSING:



Service...





ModBus TCP Log

DESCRIPTION: This screen allows the technician to view the status of all ModBus TCP communications.

Refer to the Communications manual for detailed information on this screen (090-020 CS).

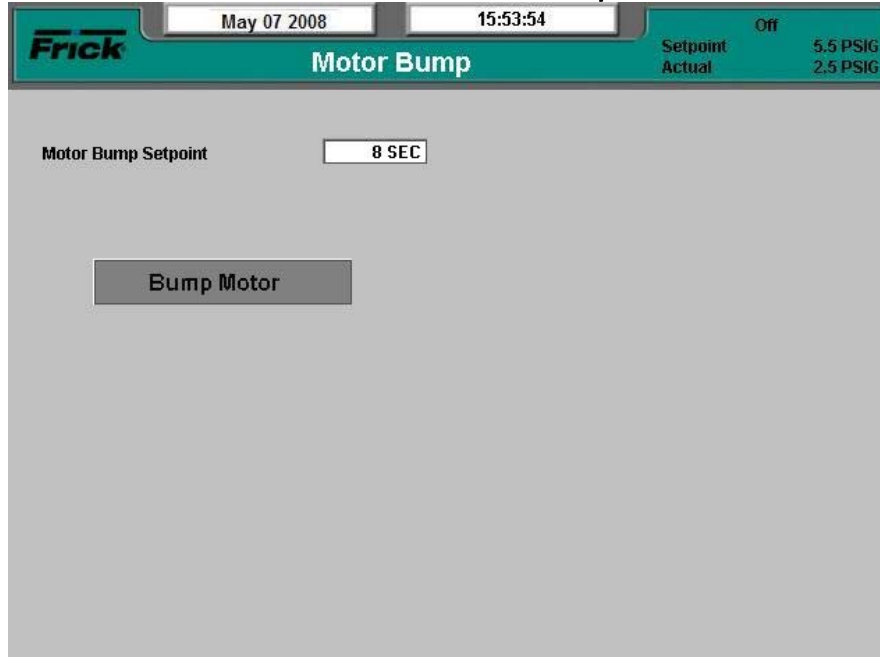
SERVICE - *Motor Bump*



ACCESSING:  → **Service...** → **Motor Bump**

DESCRIPTION: This screen allows the technician to manually energize, or bump, the compressor motor for the purpose of determining motor rotation.

The following setpoint box has been provided:

- **Motor Bump Setpoint** – Set this value to the length of time that you wish to have the compressor motor energized, or “bumped”. The range is 0.0 to 15.0 seconds.

The following user selectable buttons are provided:

- **[Bump Motor]** – When this button is selected, the compressor motor will be energized, or “bumped” for the period of time as set in the *Motor Bump Setpoint* box.

SERVICE - *Communications Loop Back Test*

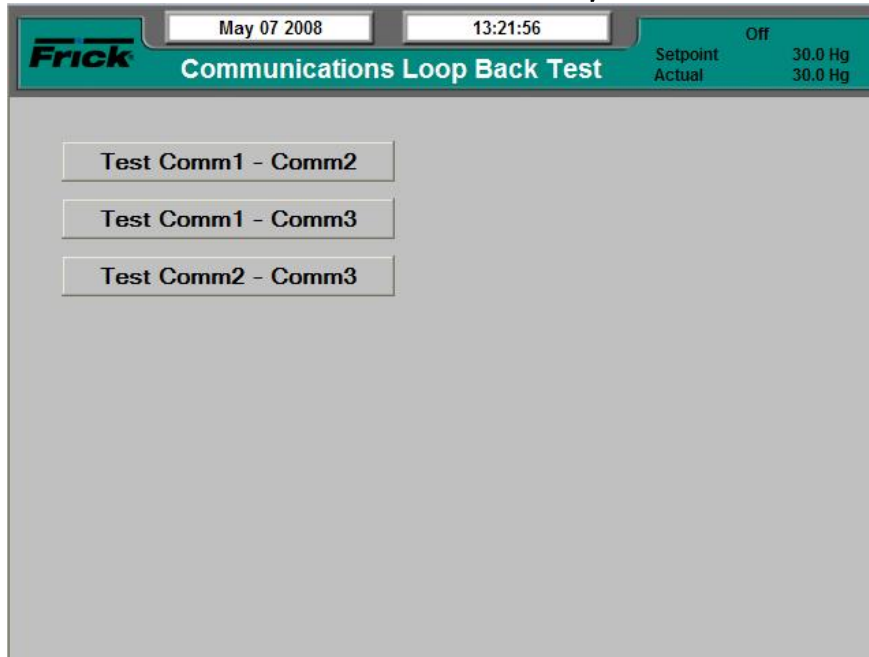

ACCESSING:



Service...

Communications Loop Back Test

DESCRIPTION: This screen allows the technician to verify and troubleshoot communications issues.

Refer to the Communications Manual (090-020CS) for specific information about this test.

SERVICE - *Diagnostics*



ACCESSING:



Service...

Diagnostics

DESCRIPTION: This screen allows the technician to perform system checks on ethernet communications.

Refer to the Communications Manual (090-020CS) for specific information about this test.

SERVICE – Software Maintenance

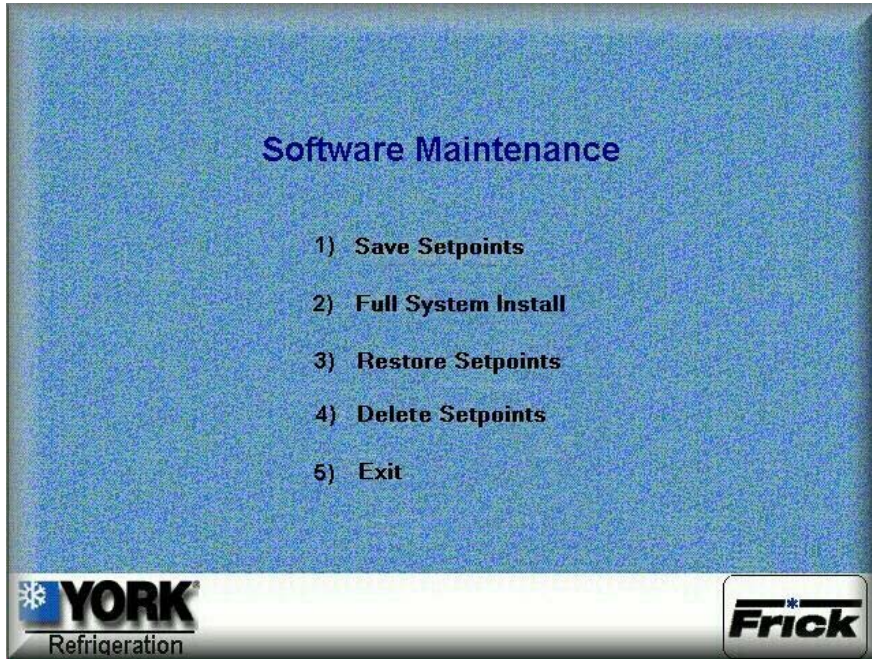

ACCESSING:  → **Service...** → **Software Maintenance**

DESCRIPTION: The *Software Maintenance* screen has been provided as a way for the user to upload the operating software to their system, to save setpoints or to restore setpoints. **NOTE:** Before accessing this screen, it is recommended that a USB adapter, with a USB drive device (P/N 649A1063G01) be plugged into the PL8 USB port of the Quantum™.

NOTE: Use caution when accessing this screen remotely with a web browser.

The following selections have been provided:

1) Save Setpoints - Use this option to save all setpoints and custom text to a USB device as a form of backup:

- Ensure that all setpoint values have been documented as a safety precaution. Install a USB device into the provide connection on the Quantum™.
- Press the **[1]** button.
- The software program will read the USB device, and the following dialog box will appear:

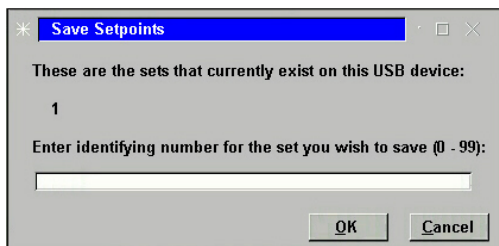

- Any numerals that appear on the center line of this box will represent units that have

already been saved (from 0 to 99). If no units have yet been saved, the center line will be blank.

- Enter a number on the keypad that corresponds to the unit number that you wish to save, and then press **[Enter]**. If the unit number has not been saved before, the setpoints will be saved to a file on the USB device (a progress bar will appear asking you to *Please Wait...* In the future, any time you try to write the setpoints to this number, you will be prompted with a message telling you that *the set number already exists – do you wish to overwrite it?* Answer by highlighting the *Yes* button, and pressing **[Enter]** if you do indeed wish to overwrite the values. If you enter a number that does not appear on the center line, no such warning will appear.
- After the file has been written or updated, the dialog boxes will disappear, and you can either exit, or continue with another function.

2) Full System Install - Use this option to install the program:

- Ensure that all setpoint values have been documented as a safety precaution.

- Press the [2] button.
- If a valid USB device with the operating system loaded on it is plugged in, the software will be loaded. If however, there is no USB device installed, or the device does not contain the operating software, the following dialog box will appear:

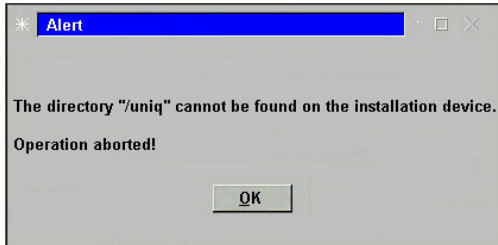

- If the above dialog box appears, you must insert a valid software upgrade USB device.

3) **Restore Setpoints** – Use this option to re-load previously saved setpoints and custom text to the Quantum™.

- Ensure that all setpoint values have been documented as a safety precaution. Install the previously saved setpoint USB device into the provided connection on the Quantum™.
- Press the [3] button.
- The software program will read the USB device, and the following dialog box will appear:

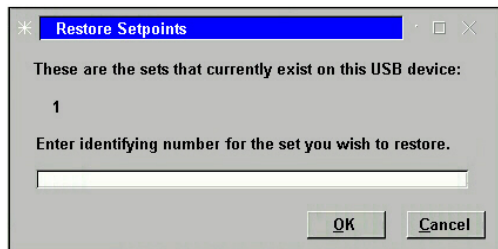

- Any numerals that appear on the center line of this box will represent units that have already been saved (from 0 to 99). If no units have yet been saved, the center line will be blank and therefore there are no setpoints to restore.
- Enter a number on the keypad that corresponds to the unit number that you wish to restore, and then press [Enter].
- A progress bar will appear asking you to *Please Wait...*
- After the file has been written or updated, the dialog boxes will disappear, and you can either exit, or continue with another function.

Delete Setpoints – Use this option to delete the setpoints and custom text for a particular unit:

- Ensure that all setpoint values have been documented as a safety precaution. Install the previously saved setpoints USB device into the provided connection on the Quantum™.
- Press the [4] button.
- The software program will read the USB device, and the following dialog box will appear:

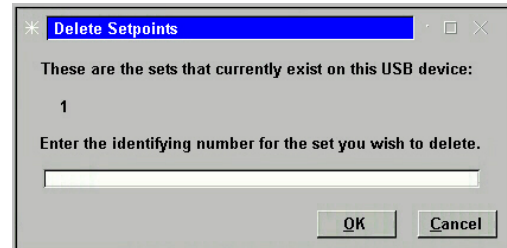

- Any numerals that appear on the center line of this box will represent units that have already been saved (from 0 to 99). If no units have yet been saved, the center line will be blank, and therefore there are no setpoints to delete.
- Enter a number on the keypad that corresponds to the unit number that you wish to delete, highlight the *Ok* button, and then press [Enter]. You will be prompted with a new dialog box which will ask you *OK to delete set number (0-99)?*
- Highlight the *Yes* button, and press [Enter]. The dialog box will be updated with a new message stating that *Set number (0-99) has been deleted!*
- Press [Enter] to return to the Software Maintenance menu.

5) **Exit** – Use this selection to leave this screen by pressing the [5] button, the panel will reboot and return to the *Operating Status* screen.

6) A box will then appear during reboot stating that a system update file has been found. The user should then select [Yes] to allow the operating system upgrade to complete. Once this completes, the user will be prompted to turn the power off, and then on again to allow the new system to boot.

Setpoint Defaults When Performing A Quantum LX Software Upgrade

The term software upgrade refers to the whole procedure of Saving Setpoints, Full System Installs, and Restoring Setpoints when on the Software Maintenance screen. They get set to these default values even after a Restore Setpoints is performed, so the individual doing the upgrade must then set them manually to what they need to be if they are critical to the application.

To determine the setpoints and their defaults that would be affected by a revision upgrade, find the row or rows corresponding to the Software Version that you will be upgrading to. On that row or rows you can see the setpoints and their related defaults.

Here are some examples:

- If upgrading from 6.48 to 6.51, then both the *PowerPAC Flag* and the *Ethernet Process Enable* setpoints will be changed to the defaults shown for each.
- If upgrading from 6.48 to 6.52, then the *PowerPAC Flag*, *Ethernet Process Enable*, *Regulation Mode* and *Max Slide Valve timer*

setpoints will be changed to the defaults shown for each.

- If upgrading from 6.51 to 6.55 (both shown on this chart), then the *PowerPAC Flag*, *Ethernet Process Enable* would have already been changed when you had initially upgraded to 6.51 and will not change again. But now that you are upgrading to 6.55, additionally the *Regulation Mode*, *Max Slide Valve timer*, *Compressor Type*, *Pump Type*, *Process Leaving Temp. Safeties*, *Compressor Types in the Sequencing Systems* and the *Compressor Start #'s in the Sequencing Systems* setpoints will be changed to the defaults shown for each.

The main message here is ensure that the Setpoint Data Sheets within this manual are filled out, and that when performing any software upgrade, first save your existing setpoints to a Setpoint Saver Card for later use. After completing an upgrade to one of the versions shown here, and then restoring your original setpoints, review this chart and compare the setpoints shown against what the program sees, and make changes to these defaults as necessary.

Setpoint Description	Default	Software Version
PowerPAC Flag	No	6.51
Ethernet Process Enable	Disabled	6.51
Regulation Mode	Mode 1	6.52
Max Slide Valve Timer	30 (tenths of secs)	6.52
Compressor Type	RWF	6.55
Pump Type	Demand	6.55
Process Leaving Temp. Safeties	Disabled	6.55
Compressor Types in the Sequencing Systems	RWF	6.55
Compressor Start #'s in the Sequencing Systems	1	6.55
Filter Differential Calculation	Filter - Oil	6.58
Allen Bradley Checksum Type for Comm 1, 2, & 3	BCC	6.58
Pump Type	Demand	6.59

DOCUMENTATION



Setpoint	Off
Actual	20.0 PSIG
	30.0 Hg

Documentation

Manuals

Communications Setup [S90-020_CS.pdf](#)

Maintenance [S90-020_M.pdf](#)

Operation [S90-022_O.pdf](#)

ACCESSING:



Documentation

DESCRIPTION: This screen provides the user with links to allow the user to view the manuals shown. These manuals are stored on the Quantum™ LX program flash card.

The screen shown here is only available when viewing from a web browser. It can be viewed by accessing the main *Menu*, and selecting *Documentation*. This screen allows the user to access the listed manuals in a PDF

format. The manuals are stored internally on the program flash card, and when selected, will be automatically displayed on a new web browser page.

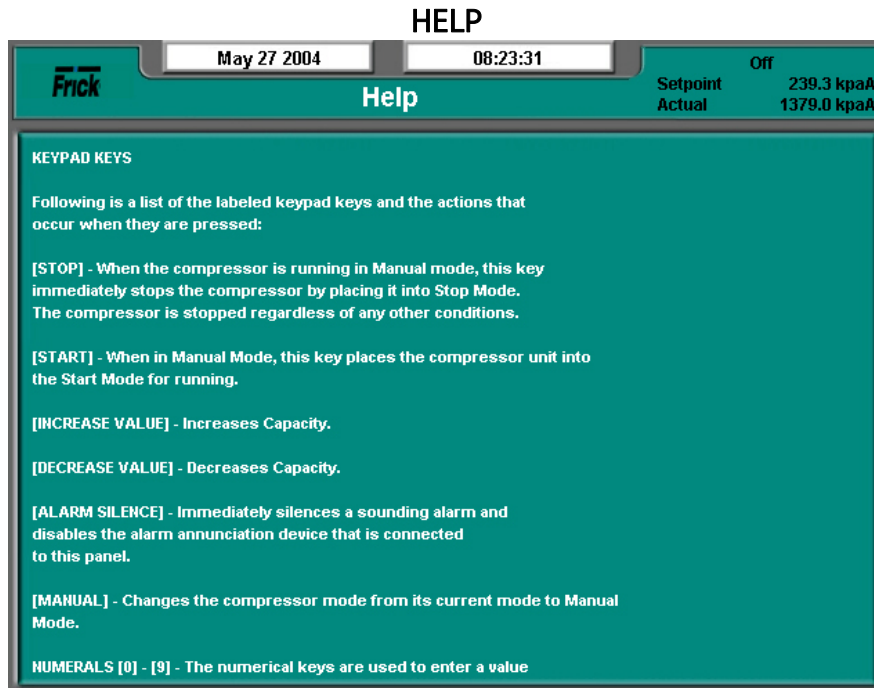

ACCESSING:



Help

DESCRIPTION: This screen provides the user with specific information as to the function of all keypad keys, as well as all screen keys, and changing Setpoints.

This screen provides a written description for each of the keys on the keypad.

ABOUT

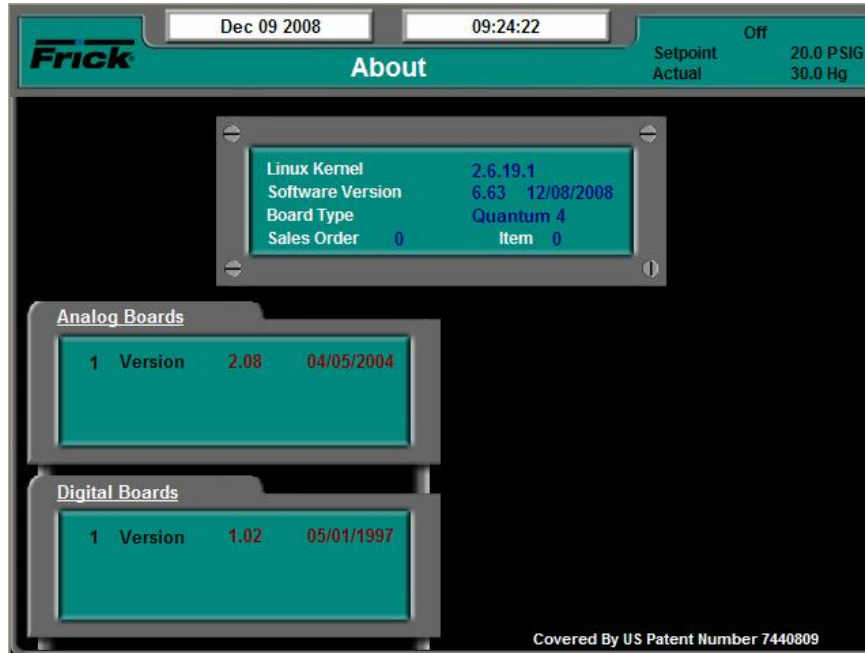

ACCESSING:



About

DESCRIPTION: The *About* screen shows all microprocessor-based circuit boards that have been detected by the Quantum™ LX, as well other related software information.

The following information is shown here:

Linux Kernel - The Quantum™ LX controller runs on a Linux programming architecture (rather than Microsoft Windows). This is the software version number for the main Linux Kernel (or program).

Software Version - This is the version of the software program that does the actual control of the compressor. It runs in the Linux environment.

Board Type - The type and model of controller will be shown here.

Sales Order - A six digit numerical value that has been assigned to a specific compressor package by Frick Company. It is very important to have this number available when calling the factory for assistance or parts ordering.

Item - This is actually an extension of the Sales Order number. It would potentially be used for a multiple compressor site, where the same Sales Order number was assigned for all compressors. The Item Number would be different for each compressor.

Analog Boards - Shows all analog boards that were detected through communications at the last power up. If a board is detected, the software version of the program running on that board (with date of the software) will be shown.

Digital Boards - Shows all digital boards that were detected through communications at the last power up. If a board is detected, the software version of the program running on that board (with date of the software) will be shown.

IO Boards - Shows all other I/O boards that were detected through communications at the last power up. If a board is detected, the software version of the program running on that board (with date of the software) will be shown.

Drive Controller - Shows motor or engine drive controllers that were detected through communications at the last power up. If a board is detected, the software version of the program running on that board (with date of the software) will be shown.

MISCELLANEOUS SCREENS

ALPHA

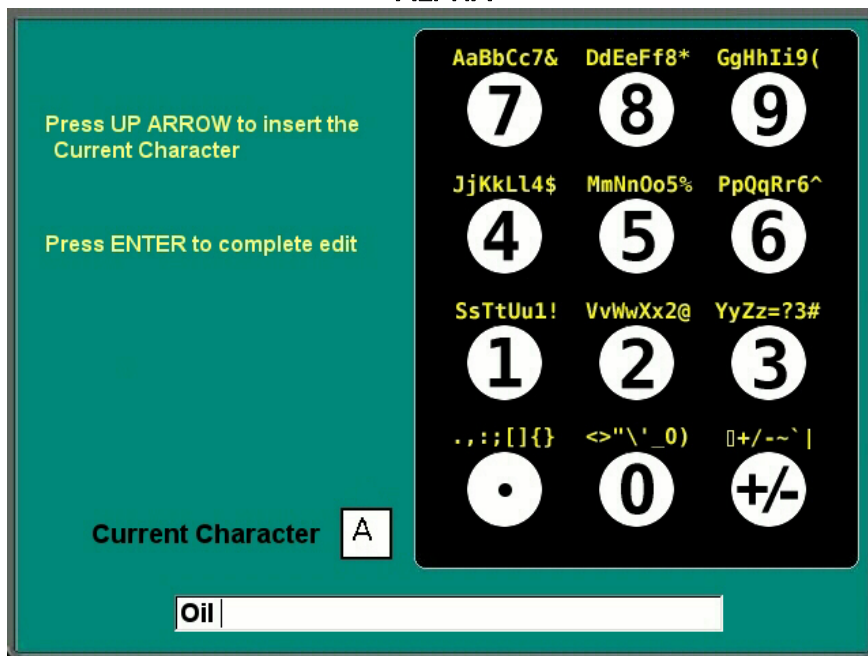

The *Alpha* screen shows a graphic representation of the Quantum™-LX numerical keypad. It is accessible from any screen that allows the user to enter alpha/numeric data, such as the *Maintenance* screen, for example. The symbols that appear above each key on this screen, are the possible combinations of symbols that are associated with the digital portion of the key. As an example, by pressing the number 7 on the keypad will cause an alpha **A** to appear in the *Current Character* box. Pressing the number 7 again will cause the capital **A** to be replaced with a small **a** (this is the next letter in the line above the numeral 7). Continuing to press the 7 key will cycle through the remaining letters above the key, and then start over.

As a example, suppose that you wanted to modify the text line in the screen example shown above. You want to change the line from reading *Oil*, to *Low Oil 2*. The first thing you would do, is to use the **[Left Arrow]** key on the keypad, to position the cursor (blinking vertical line), to the far left side of the text. Press the numeral **[4]** key (notice that the capital **L**, for *Low*, is one of the symbols in the line right above the numeral **[4]** key). A capital **L** will appear in the *Current Character* box. Continue press the numeral **[4]** until the capital **L** appears there. Now press

the **[Up Arrow]** key, and notice that the **L** has been placed on the text line in the first position. Next press the numeral **[5]** key on the keypad, and continue pressing it until the small **o** appears in the *Current Character* box. Press the **[Up Arrow]** key to place the **o** on to the text line. Now to finish the word *Low*, press the **[2]** key until the small **w** appears in the *Current Character* box, then press the **[Up Arrow]**. This will complete the word *Low*, but we need to add a space after it. The symbol for a space is , which is located above the **[+/-]** key. Press the **[+/-]** key, until the *Current Character* box contains nothing (the does not appear) then press the **[Up Arrow]** key to enter it on the text line. Finally, use the **[Right Arrow]** key, to move the blinking cursor to the right of the word *Oil*, and press the **[Up Arrow]** key again to enter the space (since the space was the last character entered, it can continue to be placed as many times as you would like on the line by pressing the **[Up Arrow]** key). After entering the space, press the numeral **[2]** key until the digit **2** appears in the *Current Character* box, then press the **[Up Arrow]** key. When you are satisfied with the changes that you have made, press the **[Enter]** key to accept them, and you will be returned to the previous screen.

OPERATION OVERVIEW

INITIAL SETUP PROCEDURE

1. Compressor Configuration should be performed by a Factory Representative or Distributor to setup the customer specific control features which should not need to be changed by operators.
2. *Configuration* is performed to setup panel features and options, which can later be changed by an operator. Features such as the panel time, and screen saver are changed here. Options such as Condenser Control are enabled here. The operator can avoid viewing and entering settings of unused controls by keeping unused options disabled.
3. Calibrate the control devices.
4. Enter and setup all control settings.
5. Establish the desired access rights of the operators.
6. The *Operating Status* screen now provide quick access to the most important information and controls of the compressor unit and the subsystems.

COMPRESSOR START-UP PROCEDURE

- Starting is shown for the Compressor status on the *Operating Status* screen.
- All the safeties are checked. If any shutdown condition is present the corresponding alarm message is shown and the compressor is prevented from starting.
- If the compressor type has been set to *Other Compressor*.
 - The oil lubrication is checked. A Prelube pump needs a 5 lb. oil pressure differential to allow the compressor to start. A full time pump needs a 20 lb. Oil Pressure differential to allow the compressor to start. Other compressor manufacture's Oil Pumps needs a 30 lb. Oil Pressure differential to allow the compressor to start. If one of these conditions is not present an alarm message is issued and the compressor is prevented from starting.
- The Slide Valve position is checked to see if it is less than or equal to the *Highest Slide Valve Position to allow starting the compressor* setpoint. If the Slide Valve position is higher than this, the compressor is prevented from starting.
- If none of the above conditions has prevented the compressor from starting, a timer delay is started that requires the starting conditions to remain satisfied for a period of five seconds for all compressor model types except **[Other**

Compressor Manuf]. The *Other* compressor model type uses a 20 seconds delay. After the time delay the compressor and the Recycle Delay timer are started.

- If within 30 seconds, the Compressor Start Auxiliary input has not been energized, or Motor Current is not detected, then an alarm message is issued and the compressor is shut down.
- When the compressor begins running, the Oil Pressure values are in a state of change. For a period of 10 seconds after the compressor status switches to *Running*, the low Oil Pressure alarm and shutdown safeties are ignored.

COMPRESSOR STOPPING PROCEDURE

During the compressor stopping, the Slide Valve unload solenoid remains energized until the Slide Valve is unloaded to or below the *Highest slide valve position to allow starting the compressor* setpoint. If the Slide Valve does not unload below this setpoint within 5 minutes, the alarm message *Compressor Unable to Unload - Alarm* is issued.

SETUP FOR AUTOMATIC CONTROL

In order to operate a compressor at peak efficiency, under full load and part load conditions complex control sequences must be used. In order to obtain the efficiencies, Automatic Control is almost mandatory. Automatic control of the Slide Stop and Slide Valve increases the compressor efficiency over a wide operating range. The following steps (which are relevant) should be taken to control in Automatic:

- The compressor should be in automatic (automatic cycling) so the compressor will start and stop according to the Autocycle setpoints.
- The Oil Pump should be in auto because it's operation coincides with that of the compressor.
- The Slide Valve and the Slide Stop should be in Automatic so they are controlled by setpoints and internal control logic.

Note: If there is a shutdown in response to a safety setting, a compressor in *Automatic* mode is placed into *Manual* mode requiring operator intervention.

REMOTE CONTROL OF THE COMPRESSOR

The following digital outputs and inputs (on Digital Board 2) have been provided that can be used to control the compressor from another controller such as a PLC:

- (Module 1) - **Ready to Run** - This output is energized while the compressor is not

shutdown and the Recycle Delay has timed out.

- (Module 2) - **Remote Enabled** - This output is energized while the compressor is in Remote Start mode.
- (Module 3) - **Remote Start / Run / Stop** - If the compressor is in Remote Start mode with no Recycle Delay time and this input is energized, the compressor is started. If this input is energized and the compressor is started, it will continue to run. If this input is de-energized, the compressor is stopped.
- (Module 4) - **Remote Load or Remote C.C step 1 for step units**
 - Remote Load - If the Slide Valve is in Remote Mode and this input is energized, the Slide Valve load solenoid will be energized provided there are no safety overrides preventing loading.
 - Remote C.C step 1 for step units - If the Capacity Mode is in Remote this input is used to step on and off capacity according to the Remote Capacity Control chart.
- (Module 6) - **Remote Unload or Remote C.C step 2 for step units**
 - Remote Unload - If the Slide Valve is in remote and this input is energized, the Slide Valve unload solenoid will be energized.
 - Remote C.C step 2 for step units - If the Capacity Mode is in Remote this input is used to step on and off capacity according to the Remote Capacity Control chart.

Remote Capacity Control Chart

Input \ %Capacity	25	50	75	100
3-Step Input 4		OFF	OFF	ON
3-Step Input 5		OFF	ON	ON
4-Step Input 4	OFF	ON	OFF	ON
4-Step Input 5	OFF	OFF	ON	ON

- Recycle Delay (If compressor is off) - This output is energized while the remaining time in minutes for Recycle Delay is greater than zero (0). Recycle delay time is the time that must elapse prior to allowing the compressor to restart. This timer times out while the compressor is running or stopped since the Recycle Delay is a start-to-start protection. The Recycle Delay time is intended to prevent damage to the

motor from successive restarts. For further setup see the **Motor Control Setpoints** screen

- Sequence Input (If compressor is on) - Reports the status of Stop Load or Force Unload (See Slide Valve and Slide Stop Status box for further details).

The *Hot Gas Bypass* option can be used. This option, is not available for all compressor models (Reference 090-020 M; *Compressor Model Differences*).

The Remote Control Setpoint option can be used. This option, which is enabled in Panel Setup is not available for all compressor models (Reference *Compressor Model Differences*). This uses the Remote Control Setpoint analog input and the Remote Control Setpoint analog output for Capacity Control of compressors. For further setup see the **Calibrate Remote Control Setpoint** screen and the **[Remote Setpoint]** command key from the Slide Valve Mode screen command keys on the **Operating Status** screen.

The Remote Slide Valve Position option can be used. This option which is enabled in Panel Setup is not available for all compressor models (Reference *Compressor Model Differences*). This uses a (4-20 ma) input signal to the Remote Slide Valve Position analog input (Channel #13 on Analog Board #1) to control the Slide Valve. For further setup see the **Calibrate Slide Valve Position** screen and the **[Remote Slide Valve]** command key from the Slide Valve Mode screen command keys on the **Operating Status** screen.

The Slide Valve Position \ Capacity analog output can be used to determine the present Slide Valve position % or Capacity % dependent on the compressor model (Reference *Compressor Model Differences*). A (4-20 ma) output signal to the Slide Valve Position \ Capacity analog output (Channel #3 on Analog Board #1) corresponds to the present (%) value displayed on the **Operating Status** screen.

ASCII communication to the Com-2 port can be used (reference 090-010 CS Communications Setup manual). A compressor should be in both Remote Compressor Mode and Remote Slide Valve or Capacity Mode for Remote Control.

Note 1: If the compressor is in *Remote* mode and communication through the communication port has not occurred for 5 minutes, then the compressor is placed into *Automatic* mode and the Slide Valve is placed into *Auto* mode.

Note 2: If there is a shutdown in response to a safety setting, a compressor in *Remote* mode is placed into *Manual* mode requiring operator intervention.

WARNINGS/SHUTDOWNS MESSAGES

When a Shutdown occurs, the display backlight will flash on and off to alert an operator of the shutdown. This visual warning will help get the attention of the operator in a noisy engine room environment where audible alarms may not be heard. Pressing any key on the keypad will clear the flashing backlight.

NOTE: refer to 100-200/210 IOM for further VSD (Vyper) message details.

Following is the alphabetical listing of all the possible conditions:

Analog Board 1 Communications Shutdown - It has been detected that the program is no longer able to communicate to Analog Board 1.

Analog Board 2 Communications Shutdown - It has been detected that the program is no longer able to communicate to Analog Board 2.

Auxiliary Input 1-20 Shutdown - The Auxiliary #1-20 input module has been setup to indicate a shutdown if it becomes de-energized.

Auxiliary Input 1-20 Warning - The Auxiliary #1-20 input module has been setup to indicate a warning if it becomes de-energized.

Balance Piston 1 Shutdown - Balance piston control has been enabled. This shutdown will occur if the difference between Discharge Pressure and Suction Pressure is less than 60 PSI and the Balance Piston output module (digital output module 12) is de-energized, then the Balance Piston pressure must be 1.1 times Suction Pressure plus or minus 15 PSI. To access this setpoint: Menu > Setpoints > Compressor.

Balance Piston 2 Shutdown - Balance piston control has been enabled. This shutdown will occur if the difference between Discharge Pressure and Suction Pressure is greater than or equal to 60 PSI and the Balance Piston output module (digital output module 12) is de-energized, then the Balance Piston pressure must be 50 PSI below Discharge Pressure plus or minus 15 PSI. To access this setpoint: Menu > Setpoints > Compressor.

Balance Piston 3 Shutdown - Balance piston control has been enabled. This shutdown will occur if the Balance Piston output module (digital output module 12) is energized, then Balance Piston pressure must be within 20 PSI of Oil Pressure. To access this setpoint: Menu > Setpoints > Compressor.

Coalescer Filter Differential Shutdown - (For RCSI only) A Shutdown will occur when the differential of Discharge Pressure to System Discharge Pressure is greater than the setpoint for its Delay period.

Coalescer Filter Differential Warning - (For RCSI only) This Warning will be issued when the differential of Discharge Pressure to System Discharge Pressure is greater than the setpoint for its Delay period.

Compressor Auxiliary Shutdown - This shutdown message is issued if while the compressor is running and the Compressor Auxiliary input module, which receives feedback from the motor starter, becomes de-energized.

Compressor Capacity Unload Warning - While stopping the compressor or if the compressor is off, this indicates that the Slide Valve position has not unloaded below the *Highest Slide Valve Position to allow starting the compressor* setpoint.

Condensing Water in Separator Warning (Off) - When the compressor is off, if the Separator Temperature was less than the sum of the calculated Dewpoint Temperature and the Off Safety Factor for the Delay period.

Condensing Water in Separator Warning (On) - When the compressor is on, if the Discharge Temperature was less than the sum of the calculated Dewpoint Temperature and the On Safety Factor for the Delay period.

DBS Communication Failure Warning - It has been detected that the program is no longer able to communicate to a RAM DBS Motor Starter. To verify the loss in communications, access Menu > Setpoints > Motor, and check the DBS Software Version. This version should read the actual version of the software, but a communications loss will return a value of 0.00.

DBS Communication Failure Shutdown - It has been detected that the program is no longer able to communicate to a RAM DBS Motor Starter. To verify the loss in communications, access Menu > Setpoints > Motor, and check the DBS Software Version. This version should read the actual version of the software, but a communications loss will return a value of 0.00.

DBS - Current Unbalance - Either the current between two phases has exceeded the setpoint value longer than the time delay setpoint, or there is a voltage unbalance between phases, or the SCR operation is abnormal. To access this setpoint: Menu > Setpoints > Motor.

DBS - HEATSINK Over-temperature - Either the temperature of the heat sink has exceeded the maximum safe operating temperature of 85 deg. C. or heat sink cable connection P2 is loose. The heatsink temperature may be viewed by accessing Menu > Setpoints > Motor.

DBS - Jam - The current exceeded the Jam Trip level set point longer than the time delay set point while in the RUN state. To access this setpoint: Menu > Setpoints > Motor.

DBS - Phase Loss – This will occur if there is a loss of at least one phase of supply voltage or the loss of at least one phase of current feedback. The three phase values may be viewed by accessing Menu > Setpoints > Motor.

DBS - Phase Reversal – Either there is an incorrect phase order at the DBS chassis input terminals, or the control power was applied before the three phase power. The three phase values may be viewed by accessing Menu > Setpoints > Motor.

DBS - RTD Overtemperature –The RTD temperature sensor is out of range. The RTD temperature may be viewed by accessing Menu > Setpoints > Motor.

DBS - RTD Temperature – The RTD temperature sensor is out of range The RTD temperature may be viewed by accessing Menu > Setpoints > Motor.

DBS - Short Circuit – The current exceeded 800% of FLA set point while the motor was starting.

DBS - Shorted SCR – This failure may occur if there is a defective SCR or a defective bypass contactor. It may also occur if the motor is disconnected. Also, inspect the main contacts of the bypass contactor.

DBS - Thermal Overload – Either the calculated thermal capacity of the motor exceeded 100% of limit, or the motor is "short-cycling".

Digital Board 1 Communications Shutdown – It has been detected that the program is no longer able to communicate to Digital Board 1.

Digital Board 1 Reset – If a reset of Digital Board 1 occurs, a shutdown will occur to prevent the motor from restarting.

Digital Board 2 Communications Shutdown – It has been detected that the program is no longer able to communicate to Digital Board 2.

Digital Board 2 Reset – If a reset of Digital Board 2 occurs, a warning will be issued.

False Running Fail -- Confirmed Running Inp – This shutdown message is issued if while the compressor is off the compressor auxiliary is energized. While this condition is present, the Oil Pump (if available) is on, and Liquid Injection (if available) is allowed on and the Slide Valve is unloaded to 0% to safeguard the compressor.

False Running Fail -- Motor Amps – This shutdown message is issued if while the compressor is off, the Motor Current reading is above the *Low Motor Amps Shutdown* setpoint. While this condition is present, the Oil Pump (if available) is on, and Liquid Injection (if available) is allowed on and the Slide Valve is unloaded to 0% to safeguard the compressor.

Harmonic Filter DC Bus Voltage Imbalance – The 1/2 DC link voltage magnitude will remain within $\pm 50\text{VDC}$ of the total DC link voltage divided by two during the precharge interval for both 60 and 50 Hz 519 filters. If not, the Quantum™ LX panel will display this message.

Harmonic Filter DC Current Transformer 1 – During initialization, the output voltage of DC Current Transformer 1 which sense the filter's input current will be monitored and compared against a level of $\pm 147\text{ mv}$ ($\pm 6010\text{ A}$ to D counts). If the offset error falls outside this range, the unit will trip and the Quantum™ LX panel will display this message.

Harmonic Filter DC Current Transformer 2 – During initialization, the output voltage of DC Current Transformer 2 which sense the filter's input current will be monitored and compared against a level of $\pm 147\text{ mv}$ ($\pm 6010\text{ A}$ to D counts). If the offset error falls outside this range, the unit will trip and the Quantum™ LX panel will display this message.

Harmonic Filter High Baseplate Temp Fault – The unit contains one heatsink assembly for the 305 Hp. The Filter's power module base plate temperature will feed the Harmonic Filter Logic board. This temperature is compared in software to a limit of 79°C and if this limit is exceeded, the unit will trip and the Quantum™ LX panel will display this message.

Harmonic Filter High DC Bus Voltage Fault – The harmonic filter's DC link voltage is continuously monitored and if the level exceeds a range of 822 to 900 VDC, a Filter Bus Over-Voltage shutdown is initiated.

Harmonic Filter High Phase A Current Fault – The unit's three phases of instantaneous output current are compared to a prescribed limit, which is contained in the hardware. If the Phase A signal exceeds the prescribed limit, the filter will be inhibited from operating by inhibiting the Current Regulator Run signal for five to six input line voltage. If the Phase A signal exceeds the prescribed threshold three times in 60 line cycles, the unit will trip and the Quantum™ LX panel will display this message.

Harmonic Filter High Phase B Current Fault – The unit's three phases of instantaneous output current are compared to a prescribed limit, which is contained in the hardware. If the Phase B signal exceeds the prescribed limit, the filter will be inhibited from operating by inhibiting the Current Regulator Run signal for five to six input line voltage. If the Phase B signal exceeds the prescribed threshold three times in 60 line cycles, the unit will trip and the Quantum™ LX panel will display this message.

Harmonic Filter High Phase C Current Fault – The unit's three phases of instantaneous output current are compared to a prescribed limit, which is contained in the hardware. If the Phase C signal exceeds the prescribed limit, the filter will be inhibited from operating by

inhibiting the Current Regulator Run signal for five to six input line voltage. If the Phase C signal exceeds the prescribed threshold three times in 60 line cycles, the unit will trip and the Quantum™ LX panel will display this message.

Harmonic Filter High Total Demand Distortion – This shutdown indicates that the filter is not operating correctly or the input current to the Vyper™ / filter system is not sinusoidal. This fault occurs when any of the three phases of Total Demand Distortion is greater than 25.0 %, for forty-five continuous seconds while the Vyper™ is running.

Harmonic Filter Input Frequency Out of Range – The Harmonic Filter monitors the line frequency on its inputs. If this frequency is out of range, it will cease filtering, and set a bit in the communications packet. This warning is shown whenever this bit is set.

Harmonic Filter Logic Board Power Supply – This shutdown indicates that one of the low voltage power supplies on the Filter Logic board have dropped below their permissible operating voltage range.

Harmonic Filter Logic Board Or Comms Fault – This fault occurs if the No Fault signal from the Vyper™ is low, indicating a fault is present at the Vyper™ or the Harmonic Filter, but the communications data contains no Harmonic Filter fault data for twenty seconds. The Frick Interface Board will send Initialize data requests while this fault is active.

Harmonic Filter Low DC Bus Voltage – The DC link voltage magnitude should remain within -80 VDC of the bus voltage setpoint determined from the peak input voltage. If the DC link voltage magnitude falls outside this range for 100 msec the unit will trip and the Quantum™ LX panel will display this message.

Harmonic Filter Phase Locked Loop Fault – This shutdown indicates that a circuit called a “phase locked loop” on the Filter Logic board has lost synchronization with the incoming power line for a period of time.

Harmonic Filter Precharge - High DC Bus Volt – The DC link voltage will reach at least 500 VDC within 20 seconds after the precharge signal has been asserted on the 60 Hz VSD and at least 414 VDC within 20 seconds on the 50 Hz VSD. If not, the Quantum™ LX panel will display this message.

Harmonic Filter Precharge - Low DC Bus Volt – This fault has two different timing events. First, the DC Bus voltage must be equal to or greater than 50 VDC for 60 Hz (41 VDC for 50 HZ) 4 seconds after precharge has begun. Second, the DC Bus voltage must be equal to or greater than 500 VDC for 60 Hz (414 VDC for 50 HZ) 20 seconds after precharge has begun. The unit is shut down and this message is generated if any of these conditions are not met.

Harmonic Filter Run Signal Fault – When a digital run command is received at the filter logic board from the Vyper™ Logic board, a 1/10 second timer is begun. A redundant run command must also occur on the serial data link from the Vyper™ Logic board before the timer expires. If not, the Vyper™ will be shut down and this Fault message will be displayed.

Harmonic Filter Serial Communication – When requesting Status data, the response data from the Harmonic Filter includes a bit that indicates whether communications were lost from the Vyper™ to the Harmonic Filter. If this bit is high for twenty consecutive seconds, this warning is indicated. This warning is also indicated whenever a receive, timeout, or checksum fault is detected on the Harmonic Filter communications, for twenty continuous seconds.

Harmonic Filter 110% Input Current Overload – The overload threshold and timer functions reside in software on the Harmonic Filter’s Logic board. The unit’s three phases of RMS output current are compared to the overload threshold magnitude. If this threshold is exceeded for 40 seconds the unit will trip and the Quantum™ LX panel will display this message.

High Auxiliary Analog 1-20 Shutdown – The Auxiliary Analog #1-20 value was greater than or equal to the high Auxiliary Analog #1-20 shutdown setpoint for its time delay.

High Auxiliary Analog 1-20 Warning – The Auxiliary Analog #1-20 value was greater than or equal to the high Auxiliary Analog #1-20 warning setpoint for its time delay.

High Auxiliary Analog Input 1-20 Sensor Warning – This warning message is issued if the sensor connected to the associated Auxiliary Analog Input channel was above the High End range for its sensor. The High End range is set by accessing Menu > Calibration > Auxiliaries > Page 1 or 2, and setting the High end. This is strictly a warning, as the compressor does not stop. This warning is logged into the Event Log.

High Bal Piston Pressure Sensor Warning – This warning message is issued if the Balance Piston Pressure reading (analog board 1, channel 10) was to the upper or maximum range (out of range) for its sensor.

High Comp. Oil Pressure Sensor Fault – This shutdown message is issued if the Oil Pressure reading (analog board 1, channel 6) was to the upper or maximum range (out of range) for its sensor.

High Comp. Oil Pressure Shutdown – The Oil Pressure was greater than or equal to the *High Oil Pressure Shutdown* setpoint for its time delay.

High Comp. Oil Temperature Shutdown – The Oil Temperature was greater than or equal to the *High Oil Temperature Shutdown* setpoint for its time delay. To access this setpoint: Menu > Setpoints > Package.

High Comp. Oil Temperature Warning - The Oil Temperature was greater than or equal to the *High Oil Temperature Warning* setpoint for its time delay. To access this setpoint: Menu > Setpoints > Package.

High Compressor Vib Shutdown - Suction - If the Suction End Compressor Vibration sensor registers a reading that is higher than the value that has been set for the *Suction End High Shutdown*, for the period of time as set for the *Suction End High Shutdown Delay*, a Shutdown will be generated.

High Compressor Vib Warning - Suction - If the Suction End Compressor Vibration sensor registers a reading that is higher than the value that has been set for the *Suction End High Warning*, for the period of time as set for the *Suction End High Warning Delay*, a Warning will be generated.

High Compressor Vib Shutdown - Discharge - If the Discharge End Compressor Vibration sensor registers a reading that is higher than the value that has been set for the *Discharge End High Shutdown*, for the period of time as set for the *Discharge End High Shutdown Delay*, a Shutdown will be generated.

High Compressor Vib Warning - Discharge - If the Discharge End Compressor Vibration sensor registers a reading that is higher than the value that has been set for the *Discharge End High Warning*, for the period of time as set for the *Discharge End High Warning Delay*, a warning will be generated.

High Disch Pres Shutdown - The Discharge Pressure was greater than or equal to the active *High Discharge Pressure Shutdown* setpoint for its time delay. To access this setpoint: Menu > Setpoints > Compressor.

High Disch Pres Warning - The Discharge Pressure was greater than or equal to the active *High Discharge Pressure Warning* setpoint for its time delay. To access this setpoint: Menu > Setpoints > Compressor.

High Disch Pres Shutdown -- Mode 2 - The Discharge Pressure was greater than or equal to the active *High Discharge Pressure Shutdown* setpoint for its time delay. To access this setpoint: Menu > Setpoints > Compressor.

NOTE: This message can only be active if Dual Discharge Pressure Mode is enabled. Also, if the Dual Mode is enabled, then the Mode 1 safeties are active for Modes 1 & 3, and the Mode 2 safeties are active for Modes 2 & 4.

High Disch Pres Warning -- Mode 2 - The Discharge Pressure was greater than or equal to the active *High Discharge Pressure Warning* setpoint for its time delay. To access this setpoint: Menu > Setpoints > Compressor.

NOTE: This message can only be active if Dual Discharge Pressure Mode is enabled. Also, if the Dual Mode is enabled, then the Mode 1 safeties are active

for Modes 1 & 3, and the Mode 2 safeties are active for Modes 2 & 4.

High Discharge Pressure Sensor Fault - This shutdown message is issued if the Discharge Pressure reading (analog board 1, channel 8) was to the upper or maximum range (out of range) for its sensor.

High Discharge Temperature Sensor Fault - This shutdown message is issued if the Discharge Temperature reading (analog board 1, channel 2) was to the upper or maximum range (out of range) for its sensor.

High Disch Temperature Sensor Warning - This warning message is issued if the Discharge Temperature reading (analog board 1, channel 2) was to the upper or maximum range (out of range) for its sensor.

High Discharge Temperature Shutdown - The Discharge Temperature was greater than or equal to the *High Discharge Temperature Shutdown* setpoint for its time delay. To access this setpoint: Menu > Setpoints > Compressor.

High Discharge Temperature Warning - The Discharge Temperature was greater than or equal to the *High Discharge Temperature Warning* setpoint for its time delay. To access this setpoint: Menu > Setpoints > Compressor.

High Economizer Gas Temp Sensor Warning - This warning message is issued if the Economizer Gas Temperature reading was to the upper or maximum range (out of range) for its sensor.

High Economizer Pressure Sensor Warning - This warning message is issued if the Economizer Pressure reading (analog board 2, channel 14) was to the upper or maximum range (out of range) for its sensor.

High Filter Pressure Sensor Warning - This warning message is issued if the Filter Pressure reading (analog board 1, channel 7) was to the upper or maximum range (out of range) for its sensor.

High Kw Monitoring Sensor Warning - This warning message is issued if the Kilowatt Monitoring reading (analog board 2, channel 16) was to the upper or maximum range (out of range) for its sensor.

High Limit Disch Pres Shutdown - The Discharge Pressure was greater than or equal to the active *High Discharge Pressure Shutdown* setpoint for its time delay.

High Limit Disch Temp Shutdown - The Discharge Temperature was greater than or equal to the active *High Discharge Temperature Shutdown* setpoint for its time delay.

High Liquid Level Sensor Warning - This warning message is issued if the Liquid Level reading was to the upper or maximum range (out of range) for its sensor.

High Liquid Level Shutdown – If the Liquid Level rises above the Liquid Level sensor, a delay timer is started. If the Level does not recover before the delay timer counts down, a Shutdown is issued.

High Main Oil Inj Pressure Sensor Warning – This warning message is issued if the Main Oil Injector Pressure reading (analog board 2, channel 15) was to the upper or maximum range (out of range) for its sensor.

High Manifold Pressure Sensor Warning – This warning message is issued if the Manifold Pressure reading was to the upper or maximum range (out of range) for its sensor.

High Manifold Pressure Shutdown – This shutdown applies if Engine Drive was enabled. When the Manifold Pressure exceeds this setpoint, an alarm will occur.

High Manifold Pressure Warning – This warning applies if Engine Drive was enabled. When the Manifold Pressure exceeds this setpoint, a warning will occur.

High Motor Current Sensor Warning – This warning message is issued if the Motor Current reading (analog board 1, channel 16) was to the upper or maximum range (out of range) for its sensor.

High Motor Current Shutdown – The motor amps was greater than or equal to the *High Motor Amps Shutdown* setpoint for its time delay. To access this setpoint: Menu > Setpoints > Motor.

High Motor Current Warning – The Motor Amps was greater than or equal to the *High Motor Amps Warning* setpoint for its time delay. To access this setpoint: Menu > Setpoints > Motor.

High Motor Stator #1 Temp Warning – If Motor Stator #1 temperature sensor registers a reading that is higher than the value that has been set for the *Motor Stator #1 Temp. Warning*, for the period of time as set for the *Motor Stator #1 Temp. Warning Delay*, a warning will be generated. The default values for these setpoints Default setpoints for this Warning are 302° F and 5 seconds.

High Motor Stator #1 Temp Shutdown – If Motor Stator #1 temperature sensor registers a reading that is higher than the value that has been set for the *Motor Stator #1 Temp. Shutdown*, for the period of time as set for the *Motor Stator #1 Temp. Shutdown Delay*, a Shutdown will be generated. The default values for these setpoints are 311° F, and 5 seconds.

High Motor Stator #2 Temp Warning – If Motor Stator #2 temperature sensor registers a reading that is higher than the value that has been set for the *Motor Stator #2 Temp. Warning*, for the period of time as set for the *Motor Stator #2 Temp. Warning Delay*, a warning will be generated. The default values for these setpoints 302° F, and 5 seconds.

High Motor Stator #2 Temp Shutdown – If Motor Stator #2 temperature sensor registers a reading that is higher than the value that has been set for the *Motor Stator #2 Temp. Shutdown*, for the period of time as set for the *Motor Stator #2 Temp. Shutdown Delay*, a Shutdown will be generated. The default values for these setpoints are 311° F, 5 seconds.

High Motor Stator #3 Temp Warning – If Motor Stator #3 temperature sensor registers a reading that is higher than the value that has been set for the *Motor Stator #3 Temp. Warning*, for the period of time as set for the *Motor Stator #3 Temp. Warning Delay*, a warning will be generated. The default values for these setpoints are 302° F, and 5 seconds.

High Motor Stator #3 Temp Shutdown – If Motor Stator #3 temperature sensor registers a reading that is higher than the value that has been set for the *Motor Stator #3 Temp. Shutdown*, for the period of time as set for the *Motor Stator #3 Temp. Shutdown Delay*, a Shutdown will be generated. The default values for these setpoints are 311° F, and 5 seconds.

High Motor Temp Shutdown - Opp Shaft Side – The motor has temperature sensors that monitor the Opposite Shaft Side bearing. If the temperature of this bearing exceeds the *Opposite Shaft Side High Shutdown* setpoint, for a period of time exceeding the *Opposite Shaft Side High Shutdown Delay* setpoint, this Shutdown will occur. The default values for these setpoints are 221° F and a delay of 5 seconds.

High Motor Temp Shutdown - Shaft Side – The motor has temperature sensors that monitor the Shaft Side bearing. If the temperature of this bearing exceeds the *Shaft Side High Shutdown* setpoint, for a period of time exceeding the *Shaft Side High Shutdown Delay* setpoint, this Shutdown will occur. The default values for these setpoints are 221° F and a delay of 5 seconds.

High Motor Temp Warning - Opp Shaft Side – The motor has temperature sensors that monitor the Opposite Shaft Side bearing. If the temperature of this bearing exceeds the *Opposite Shaft Side High Warning* setpoint, for a period of time exceeding the *Opposite Shaft Side High Warning Delay* setpoint, this Warning will occur. The default values for these setpoints are 203° F and a delay of 5 seconds.

High Motor Temp Warning - Shaft Side – The motor has temperature sensors that monitor the Shaft Side bearing. If the temperature of this bearing exceeds the *Shaft Side High Warning* setpoint, for a period of time exceeding the *Shaft Side High Warning Delay* setpoint, this Warning will occur. The default values for these setpoints are 203° F and a delay of 5 seconds.

High Motor Vib Shutdown - Opposite Shaft Side – If the Opposite Shaft Side Drive Vibration sensor registers a reading that is higher than the value that has been set for the *Opposite Shaft High Shutdown*, for the period of time

as set for the *Opposite Shaft High Shutdown Delay*, a Shutdown will be generated. The default values for these setpoints are 10 Fg and a delay of 1 second.

High Motor Vib Shutdown - Shaft Side - If the Shaft Side Drive Vibration sensor registers a reading that is higher than the value that has been set for the *Shaft Side High Shutdown*, for the period of time as set for the *Shaft Side High Shutdown Delay*, a Shutdown will be generated. The default values for these setpoints are 10 Fg and a delay of 1 second.

High Motor Vib Warning - Opposite Shaft Side - If the Opposite Shaft Side Drive Vibration sensor registers a reading that is higher than the value that has been set for the *Opposite Shaft High Warning*, for the period of time as set for the *Opposite Shaft High Warning Delay*, a warning will be generated. The default values for these setpoints are 3.5 Fg and a delay of 99 seconds.

High Motor Vib Warning - Shaft Side - If the Shaft Side Drive Vibration sensor registers a reading that is higher than the value that has been set for the *Shaft Side High Warning*, for the period of time as set for the *Shaft Side High Warning Delay*, a warning will be generated. The default values for these setpoints are 3.5 Fg and a delay of 99 seconds.

High Oil Filter Pressure Shutdown - The Oil Filter Pressure was greater than or equal to the *High Filter Pressure Shutdown* setpoint for its time delay. The default values for these setpoints are 25 PSI and a delay of 10 minutes.

High Oil Filter Pressure Warning - The Oil Filter Pressure was greater than or equal to the *High Filter Pressure Warning* setpoint for its time delay. The default values for these setpoints are 30 PSI and a delay of 15 minutes.

High Oil Pressure (Kobe) - If the compressor type is set to Other Manufacturer (Kobe), the oil pump type is set to Demand and if Oil Pressure rises above 325 PSIA for more than 5 seconds this shutdown will occur. This shutdown is only active when the compressor is running and is also not checked for the first 90 seconds after the compressor starts.

High Oil Separator Temp Sensor Warning - This warning message is issued if the Oil Separator Temperature reading (analog board 1, channel 4) was to the upper or maximum range (out of range) for its sensor.

High Oil Temperature Sensor Fault - This shutdown message is issued if the Oil Temperature reading (analog board 1, channel 3) was to the upper or maximum range (out of range) for its sensor.

High Oil Temp Compressor Sensor Warning - This warning message is issued if the Oil Temperature reading (analog board 1, channel 3) was to the upper or maximum range (out of range) for its sensor.

High Process Entering Temp Sensor Warning - This warning message is issued if the Process Entering Temperature reading (analog board 2, channel 4) was to the upper or maximum range (out of range) for its sensor.

High Process Entering Temp Shutdown - The Entering Process Temperature was greater than or equal to the *High Entering Process Temperature Shutdown* setpoint for its time delay.

High Process Entering Temp Warning - The Entering Process Temperature was greater than or equal to the *High Entering Process Temperature Warning* setpoint for its time delay.

High Process Leaving Temp Sensor Warning - This warning message is issued if the Process Leaving Temperature reading (analog board 1, channel 5) was to the upper or maximum range (out of range) for its sensor.

High Process Leaving Temp Shutdown - The Leaving Process Temperature was greater than or equal to the *High Leaving Process Temperature Shutdown* setpoint for its time delay.

High Process Leaving Temp Warning - The Leaving Process Temperature was greater than or equal to the *High Leaving Process Temperature Warning* setpoint for its time delay.

High Rem Capacity Position Sensor Warning - This warning message is issued if the Remote Capacity Position reading was to the upper or maximum range (out of range) for its sensor.

High Remote Control Setpoint Sensor Warning -

High RPM Sensor Warning - This warning message is issued if the RPM reading was to the higher or maximum range (out of range) for its sensor.

High RPM Shutdown - This shutdown applies if Engine or Turbine Drive was enabled. If the RPM's of the motor exceeds this setpoint, a shutdown will occur.

High RPM Warning - This warning applies if Engine or Turbine Drive was enabled. If the RPM's of the motor exceeds this setpoint, a warning will occur.

High Separator Temperature Sensor Fault - This shutdown message is issued if the Separator Temperature reading was to the upper or maximum range (out of range) for its sensor.

High Suction Pressure Shutdown - The Suction Pressure was greater than or equal to the active *High Suction Pressure Shutdown* setpoint for its time delay. To access this setpoint: Menu > Setpoints > Compressor.

High Suction Pressure Warning - The Suction Pressure was greater than or equal to the active *High Suction*

Pressure Warning setpoint for its time delay. To access this setpoint: Menu > Setpoints > Compressor.

High Suction Temp Sensor Warning - This warning message is issued if the Suction Temperature reading (analog board 1, channel 1) was to the upper or maximum range (out of range) for its sensor.

High System Disch Pressure Sensor Warning - This warning message is issued if the System Discharge reading (analog board 1, channel 11) was to the upper or maximum range (out of range) for its sensor.

Insufficient Main Oil Pressure Shutdown - The Slide Valve is greater than 50% and the Oil Pressure (PSIA) is less than or equal to the Suction Pressure (PSIA) multiplied by 1.5 and then added to 15.0.

Liquid Slugging Shutdown - This shutdown is triggered off of a sudden decrease in Discharge Temperature that is greater than the Liquid Slugging Shutdown setpoint for a five (5) second period. That is, if the Discharge Temperature is 130 degrees F, and the Liquid Slug Shutdown setpoint is 20 degrees F, then a sudden drop in Discharge Temperature from 130 to 110 degrees F within a five second period will generate a shutdown condition. To access this setpoint: Menu > Setpoints > Compressor.

Liquid Slugging Warning - This warning is triggered off of a sudden decrease in Discharge Temperature that is greater than the Liquid Slug Warning setpoint for a five (5) second period. That is, if the Discharge Temperature is 130 degrees F, and the Liquid Slugging Warning setpoint is 10 degrees F, then a sudden drop in Discharge Temperature from 130 to 120 degrees F within a five second period will generate a warning condition. To access this setpoint: Menu > Setpoints > Compressor.

Low Auxiliary Analog 1-20 Shutdown - The Auxiliary Analog #1-20 value was less than or equal to the low Auxiliary Analog #1-20 shutdown setpoint for its time delay. To access this setpoint: Menu > Setpoints > Auxiliaries > Analog Inputs > Pages 1-4.

Low Auxiliary Analog 1-20 Warning - The Auxiliary Analog #1-20 value was less than or equal to the low Auxiliary Analog #1-20 warning setpoint for its time delay. To access this setpoint: Menu > Setpoints > Auxiliaries > Analog Inputs > Pages 1-4.

Low Auxiliary Analog Input 1-20 Sensor Warning - This warning message is issued if the sensor connected to the associated Auxiliary Analog Input channel was below the Low End range for its sensor. To access this setpoint: Menu > Calibration > Auxiliaries > Page 1 or 2. This is strictly a warning, as the compressor does not stop. This warning is logged into the Event Log.

Low Bal Piston Pressure Sensor Warning - This warning message is issued if the Balance Piston Pressure reading (analog board 1, channel 10) was to the lower or minimum range (out of range) for its sensor.

Low Comp. Oil Pressure Sensor Fault - This shutdown message is issued if the Oil Pressure reading was to the lower or minimum range (out of range) for its sensor.

Low Comp. Oil Pressure Shutdown - If the type of compressor is a Reciprocating type, then a shutdown will occur if the Oil Pressure minus the Suction Pressure is less than the *Low Comp. Oil Pressure Shutdown* setpoint for the period of the delay. If the compressor type is set for anything other than Reciprocating, then the shutdown is based upon the following oil pump configurations:

- **No Pump** - A shutdown will occur if the Discharge Pressure minus the Oil Pressure is greater than the *Low Compressor Oil Pressure Shutdown* Setpoint for the period of the delay.
- **Full Time** - A shutdown will occur if the Oil Pressure minus the Discharge Pressure is greater than the *Low Compressor Oil Pressure Shutdown* Setpoint for the period of the delay.
- **Demand** - A shutdown will occur if the Discharge Pressure minus the Oil Pressure is greater than the *Low Compressor Oil Pressure Shutdown* Setpoint for the period of the delay.
- **Shaft pump or Shaft Aux. Pump** - A shutdown will occur if the Oil Pressure minus the Discharge Pressure is greater than the *Low Compressor Oil Pressure Shutdown* Setpoint for the period of the delay.

To access this setpoint: Menu > Setpoints > Package.

Low Comp. Oil Pressure Warning - If the type of compressor is a Reciprocating type, then a warning will occur if the Oil Pressure minus the Suction Pressure is less than the *Low Comp. Oil Pressure Warning* setpoint for the period of the delay. If the compressor type is set for anything other than Reciprocating, then the warning is based upon the following oil pump configurations:

- **No Pump** - A warning will occur if the Discharge Pressure minus the Oil Pressure is greater than the *Low Compressor Oil Pressure Warning* Setpoint for the period of the delay.
- **Full Time** - A warning will occur if the Oil Pressure minus the Discharge Pressure is greater than the *Low Compressor Oil Pressure Warning* Setpoint for the period of the delay.
- **Demand** - A warning will occur if the Discharge Pressure minus the Oil Pressure is greater than the *Low Compressor Oil Pressure Warning* Setpoint for the period of the delay.
- **Shaft pump or Shaft Aux. Pump** - A warning will occur if the Oil Pressure minus the Discharge Pressure is greater than the *Low Compressor Oil Pressure Warning* Setpoint for the period of the delay.

To access this setpoint: Menu > Setpoints > Package.

Low Comp. Oil Temperature Sensor Fault - This shutdown message is issued if the Oil Temperature reading was to the lower or minimum range (out of range) for its sensor.

Low Comp. Oil Temperature Shutdown - The Oil Temperature was less than or equal to the *Low Oil Temperature Shutdown* setpoint for its time delay. To access this setpoint: Menu > Setpoints > Package.

Low Comp. Oil Temperature Warning - The Oil Temperature was less than or equal to the *Low Oil Temperature Warning* setpoint for its time delay. To access this setpoint: Menu > Setpoints > Package.

Low Discharge Pressure Shutdown - The Discharge Pressure was less than or equal to the *Low Discharge Pressure Shutdown* setpoint for its time delay.

Low Discharge Pressure Sensor Fault - This shutdown message is issued if the Discharge Pressure reading was to the lower or minimum range (out of range) for its sensor.

Low Discharge Temperature Sensor Fault - This shutdown message is issued if the Discharge Temperature reading was to the lower or minimum range (out of range) out of range for its sensor.

Low Disch Temp Sensor Warning - This warning message is issued if the Discharge Temperature reading (analog board 1, channel 2) was to the lower or minimum range (out of range) for its sensor.

Low Economizer Pressure Sensor Warning - This warning message is issued if the Economizer Pressure reading (analog board 2, channel 14) was to the lower or minimum range (out of range) for its sensor.

Low Filter Pressure Sensor Warning - This warning message is issued if the Filter Pressure reading (analog board 1, channel 7) was to the lower or minimum range (out of range) for its sensor.

Low Kw Monitoring Sensor Warning - This warning message is issued if the Kilowatt Monitoring reading (analog board 2, channel 16) was to the lower or minimum range (out of range) for its sensor.

Low Liquid Level Sensor Warning - This warning message is issued if the Liquid Level reading was to the lower or minimum range (out of range) for its sensor.

Low Main Oil Inj Pressure Sensor Warning - This warning message is issued if the Main Oil Injection Pressure reading was to the lower or minimum range (out of range) for its sensor.

Low Main Oil Injection Pressure Shutdown - This shutdown can occur if Oil Injection was enabled. The Oil Injection Pressure (channel 15, Analog Board 2) must be greater than or equal to the Suction Pressure times 1.5, plus the setpoint to be in the safe condition, otherwise

this shutdown will occur. Used only on vertical oil separator with liquid injection oil cooled packages.

Low Manifold Pressure Sensor Warning - This warning message is issued if the Manifold Pressure reading was to the lower or minimum range (out of range) for its sensor.

Low Motor Current Sensor Warning - This warning message is issued if the Motor Current reading (analog board 1, channel 16) was to the lower or minimum range (out of range) for its sensor.

Low Motor Current Shutdown - This shutdown message is issued if, while the compressor was running, the Motor Amps reading was less than or equal to the *Low Motor Amps Shutdown* setpoint. To access this setpoint: Menu > Setpoints > Motor.

Low Oil Differential 1 (Kobe) - If the compressor type is set to Other Manufacturer (Kobe), the oil pump type is set to Demand and if the differential between Oil Pressure and Suction Pressure is less than 50 PSI for 5 seconds this shutdown will occur. This shutdown is only active when the compressor is running and is also not checked for the first 90 seconds after the compressor starts.

Low Oil Differential 2 (Kobe) - If the compressor type is set to Other Manufacturer (Kobe), the oil pump type is set to Demand and the differential between Oil Pressure and Suction Pressure is less than Suction Pressure times 0.8 for 5 seconds this shutdown will occur. This shutdown is only active when the compressor is running and is also not checked for the first 90 seconds after the compressor starts.

Low Oil Separator Temp Sensor Warning - This warning message is issued if the Oil Separator Temperature reading (analog board 1, channel 4) was to the lower or minimum range (out of range) for its sensor.

Low Oil Temp Compressor Sensor Warning - This warning message is issued if the Oil Temperature reading (analog board 1, channel 3) was to the lower or minimum range (out of range) for its sensor.

Low Process Entering Temp Sensor Warning - This warning message is issued if the Process Entering Temperature reading (analog board 2, channel 4) was to the lower or minimum range (out of range) for its sensor.

Low Process Entering Temp Shutdown - The Entering Process Temperature was less than or equal to the *Low Entering Process Temperature Shutdown* setpoint for its time delay.

Low Process Entering Temp Warning - The Entering Process Temperature was less than or equal to the *Low Entering Process Temperature Warning* setpoint for its time delay.

Low Process Leaving Temp Sensor Warning - This warning message is issued if the Process Leaving

Temperature reading (analog board 1, channel 5) was to the lower or minimum range (out of range) for its sensor.

Low Process Leaving Temp Shutdown - The Leaving Process Temperature was less than or equal to the *Low Leaving Process Temperature Shutdown* setpoint for its time delay.

Low Process Leaving Temp Warning - The Leaving Process Temperature was less than or equal to the *Low Leaving Process Temperature Warning* setpoint for its time delay.

Low Rem Capacity Position Sensor Warning - This warning message is issued if the Remote Capacity Position reading was to the lower or minimum range (out of range) for its sensor.

Low Remote Control Setpoint Sensor Warning -

Low RPM Sensor Warning - This warning message is issued if the RPM reading was to the lower or minimum range (out of range) for its sensor.

Low RPM Shutdown - This shutdown applies if Engine or Turbine Drive was enabled. If the RPM's of the motor drops below this setpoint, a shutdown will occur. To access this setpoint: Menu > Setpoints > Engine.

Low RPM Warning - This warning applies if Engine or Turbine Drive was enabled. If the RPM's of the motor drops below this setpoint, a warning will occur. To access this setpoint: Menu > Setpoints > Engine.

Low Separator Temperature Sensor Fault - This shutdown message is issued if the Separator Temperature reading was to the lower or minimum range (out of range) for its sensor.

Low Separator Temperature Shutdown - The Oil Separator Temperature was less than or equal to the *Low Oil Separator Temperature Shutdown* setpoint for its time delay. To access this setpoint: Menu > Setpoints > Package.

Low Separator Temperature Warning - The Oil Separator Temperature was less than or equal to the *Low Oil Separator Temperature Warning* setpoint for its time delay. To access this setpoint: Menu > Setpoints > Package.

Low Suction Pressure Sensor Fault - This shutdown message is issued if the Suction Pressure reading was to the lower or minimum range (out of range) for its sensor.

Low Suction Shutdown -- Mode 1 - When running in Mode 1, if the Suction Pressure was less than or equal to the active Mode 1 *Low Suction Shutdown* setpoint for its time delay.

Low Suction Shutdown -- Mode 2 - When running in Mode 2, if the Suction Pressure was less than or equal to

the active Mode 2 *Low Suction Shutdown* setpoint for its time delay.

Low Suction Shutdown -- Mode 3 - When running in Mode 3, if the Suction Pressure was less than or equal to the active Mode 3 *Low Suction Shutdown* setpoint for its time delay.

Low Suction Shutdown -- Mode 4 - When running in Mode 4, if the Suction Pressure was less than or equal to the active Mode 4 *Low Suction Shutdown* setpoint for its time delay.

Low Suction Temp Sensor Warning - This warning message is issued if the Suction Pressure reading (analog board 1, channel 1) was to the lower or minimum range (out of range) for its sensor.

Low Suction Warning -- Mode 1 - When running in Mode 1, if the Suction Pressure was less than or equal to the active Mode 1 *Low Suction Warning* setpoint for its time delay. To access this setpoint: Menu > Setpoints > Capacity Control > Mode 1.

Low Suction Warning -- Mode 2 - When running in Mode 2, if the Suction Pressure was less than or equal to the active Mode 2 *Low Suction Warning* setpoint for its time delay. To access this setpoint: Menu > Setpoints > Capacity Control > Mode 2.

Low Suction Warning -- Mode 3 - When running in Mode 3, if the Suction Pressure was less than or equal to the active Mode 3 *Low Suction Warning* setpoint for its time delay. To access this setpoint: Menu > Setpoints > Capacity Control > Mode 3.

Low Suction Warning -- Mode 4 - When running in Mode 4, if the Suction Pressure was less than or equal to the active Mode 4 *Low Suction Warning* setpoint for its time delay. To access this setpoint: Menu > Setpoints > Capacity Control > Mode 4.

Low System Disch Pressure Sensor Warning - This warning message is issued if the System Discharge Pressure reading (analog board 1, channel 11) was to the lower or minimum range (out of range) for its sensor.

Manual Stop Shutdown (RCSI only) -

Missing Comp. Oil Pressure Shutdown A - The Oil Pressure (PSIA) is less than the Suction Pressure (PSIA) multiplied by 1.1 and then added to 15.0, then delayed by 2 min.

Missing Comp. Oil Pressure Shutdown B - The Oil Pressure (PSIA) is less than the Suction Pressure (PSIA) added to 15.0, then delayed by 25 sec.

Missing Comp. Oil Pressure Warning - The Oil Pressure (PSIA) is less than the Suction Pressure (PSIA) multiplied by 1.1 and then added to 15.0, then delayed by 25 sec.

Mode 1 Shutdown – When the selected regulation control input for Mode 1 has exceeded its shutdown setpoint for the delay period, a Shutdown occurs.

Mode 1 Warning – When the selected regulation control input for Mode 1 has exceeded its warning setpoint for the delay period, a Warning occurs.

Mode 2 Shutdown – When the selected regulation control input for Mode 2 has exceeded its shutdown setpoint for the delay period, a Shutdown occurs.

Mode 2 Warning – When the selected regulation control input for Mode 2 has exceeded its warning setpoint for the delay period, a Warning occurs.

Mode 3 Shutdown – When the selected regulation control input for Mode 3 has exceeded its shutdown setpoint for the delay period, a Shutdown occurs.

Mode 3 Warning – When the selected regulation control input for Mode 3 has exceeded its warning setpoint for the delay period, a Warning occurs.

Mode 4 Shutdown – When the selected regulation control input for Mode 4 has exceeded its shutdown setpoint for the delay period, a Shutdown occurs.

Mode 4 Warning – When the selected regulation control input for Mode 4 has exceeded its warning setpoint for the delay period, a Warning occurs.

Oil Level Shutdown – The corresponding input module for Low Oil Level (analog board 1, module 13) was de-energized for five (5) minutes. To access this setpoint: Menu > Setpoints > Package.

Oil Log Shutdown – Oil log was enabled and the Compressor has not started and the Oil Pump has already run for the fail delay time. To access this setpoint: Menu > Setpoints > Compressor.

Oil Pump Auxiliary Failure – While starting the Oil Pump, the Oil Pump Auxiliary input module did not energize within five (5) seconds, or, while the Oil Pump was running, the Oil Pump Auxiliary input module de-energized.

Oil Pump 1 Auxiliary Warning – While starting Oil Pump #1, the Oil Pump #1 Auxiliary input module did not energize within five (5) seconds, or, while this Oil Pump was running, the Oil Pump #1 Auxiliary input module de-energized. This indicates Dual Pump Control and *Pump #1* is the lead pump.

Oil Pump 1 Auxiliary Shutdown – While starting Oil Pump #1, the Oil Pump #1 Auxiliary input module did not energize within five (5) seconds, or, while this Oil Pump was running, the Oil Pump #1 Auxiliary input module de-energized. This indicates Dual Pump Control and *Pump #1* is the last pump to start.

Oil Pump 2 Auxiliary Warning – While starting Oil Pump #2, the Oil Pump #2 Auxiliary input module did not energize within five (5) seconds, or, while this Oil Pump was running the Oil Pump #2 Auxiliary input module de-energized. This indicates Dual Pump Control and *Pump #2* is the lead pump.

Oil Pump 2 Auxiliary Shutdown – While starting Oil Pump #2, the Oil Pump auxiliary input module did not energize within five (5) seconds, or, while the Oil Pump was running, the Oil Pump auxiliary input module de-energized. This indicates Dual Pump Control and *Pump #2* is the last pump to start.

Process Stopped - See Event Log – One of the control program subroutine processes has stopped functioning and a message has been entered into the event log. This is a Warning message.

Slide Valve Failure Shutdown – When in sequencing mode, if the controlling compressor fails to properly load the Slide Valve, a shutdown occurs, and control moves to the next compressor.

Start Failure Shutdown For Eng And Turb – This message may be issued if Engine or Turbine was enabled, and the start delay period to get to a running condition has expired.

Starting Failure - Low Motor Amps – This shutdown message is displayed if after 30 seconds from sending the compressor start signal, the Motor Amps reading is not greater than the *Low Motor Amps Shutdown* setpoint. To access this setpoint: Menu > Setpoints > Motor.

Starting Failure - No Compressor Auxiliary – This shutdown message is displayed if after 450 seconds from sending the compressor start command, the compressor auxiliary input module is still not energized.

VSD Communication Failure Warning – If Vyper option is enabled and communications has been lost between the Quantum™ LX and the VSD driver for over five seconds, this warning is shown.

VSD Board NovRAM Failure – The integrity of the NovRAM is verified on every power-up. A known value is written to a specified location in NovRAM, read back from that location, and compared to the value originally written. If the two values do not match, the NovRAM Failure fault is displayed.

VSD Board Motor Current > 15% – This fault occurs whenever the Vyper™ is running and a motor current of less than 10 % FLA is detected for at least twenty-five continuous seconds. This fault is only checked when the Run Acknowledge output is engaged. Therefore, it is NOT checked during STANDBY, which prevents this fault from occurring during STANDBY.

VSD Board Power Supply Fault – The various DC power supplies which power the Board are monitored via

hardware located on the Board. If any of these power supplies fall outside their allowable limits, the unit will trip and the Quantum™ LX Panel will display the fault message.

VSD Board Run Signal Fault - This fault occurs if the Run Signal from the Quantum Control Panel is high, but the speed command being sent over the RS-485 communications link is zero. It may also occur if the Run Signal is low, but the speed command is not zero. Both conditions must be present for five seconds before the fault is set, and are only applicable in automatic mode.

VSD Board to Panel Comms Loss - This fault occurs when the Frick Interface Board loses communications from the Quantum™ LX Control Panel, meaning it has not received any data for a period of fifteen seconds. It is only applicable in automatic mode.

VSD Current Imbalance Fault - When the average of the three output phase currents exceeds 80% of the 100% Job FLA, the % Output Current Imbalance is calculated using the following equation:
$$\left[\left(I^a - I^{ave} \right) + \left(I^b - I^{ave} \right) + \left(I^c - I^{ave} \right) \right] / \left[2 \cdot I^{ave} \right] [100]; I^{ave} = (I^a + I^b + I^c) / 3.$$
 If the % Imbalance exceeds 30% continuously for 45 seconds the unit shall trip and the Quantum™ LX panel shall display this message. The imbalance fault is disabled when the average of the three output phase currents drops below 80% FLA.

VSD DC Bus Voltage Imbalance Fault - The 1/2 DC link voltage magnitude must remain within ± 88 VDC of the total DC link voltage divided by two for both 60 and 50 Hz VSD's. If the 1/2 DC link magnitude exceeds the ± 88 volt window, the unit will trip and the Quantum™ LX will display this message.

VSD High Converter Heatsink Temp Fault - A thermistor sensor is located behind the last SCR/Diode block on the copper chill plate of the Vyper™ Power Unit. If at anytime this thermistor detects a temperature of 170°F (76°C) or higher, a shutdown will occur. The cooling fans and coolant pump on the Vyper™ will continue to run after the shutdown, until the thermistor temperature has dropped to below 160°F (71°C). This shutdown requires a manual reset via the Reset push button on the Vyper™ Logic board.

VSD High DC Bus Voltage Fault - The DC link overvoltage trip level is determined by hardware on the logic board and it is designed to trip the unit at 745 +/- 17 VDC for both 60 and 50 Hz VSD's. If the DC bus current exceeds this level, the unit will trip and the Quantum™ LX Panel will display this message.

VSD High Internal Ambient Temp Fault - The logic board contains a temperature sensor which monitors the unit's internal ambient temperature. The magnitude of the unit's internal temperature is compared to a limit of 145°F. If this limit is exceeded the unit will trip and the Quantum™ LX panel will display this message. The fan(s) and water pump

remain energized until the internal temperature drops below 137°F. The fan(s) and water pump will be de-energized when the internal temperature drops below 137°F.

VSD High Inverter Baseplate Temp Fault - A thermistor sensor is located inside the IGBT Module on the Vyper™ power unit. If at anytime this thermistor detects a temperature of 175°F (79°C) or higher, a shutdown will occur. The cooling fans and coolant pump on the Vyper™ will continue to run after the shutdown, until the thermistor temperature has dropped to below 165°F (74°C). This shutdown requires a manual reset via the Reset push button on the Vyper™ logic board.

VSD High Phase A Instantaneous Current - Phase A of the output line to the motor is monitored via a current transformer within the drive. The unit's Phase A of instantaneous output current is compared to a prescribed limit which is contained in the hardware. If the peak current limit is exceeded, the unit will trip and the Quantum™ LX Panel will display this message.

VSD High Phase B Instantaneous Current - Phase B of the output line to the motor is monitored via a current transformer within the drive. The unit's Phase B of instantaneous output current is compared to a prescribed limit which is contained in the hardware. If the peak current limit is exceeded, the unit will trip and the Quantum™ LX Panel will display this message.

VSD High Phase C Instantaneous Current - Phase C of the output line to the motor is monitored via a current transformer within the drive. The unit's Phase C of instantaneous output current is compared to a prescribed limit which is contained in the hardware. If the peak current limit is exceeded, the unit will trip and the Quantum™ LX Panel will display this message.

VSD High Phase A Inverter Baseplate Temp - A thermistor sensor is located inside the IGBT Module on the Vyper™ power unit. If at anytime this thermistor detects a temperature of 175°F (79°C) or higher of the Phase A Inverter, a shutdown will occur. The cooling fans and coolant pump on the Vyper™ will continue to run after the shutdown, until the thermistor temperature has dropped to below 165°F (74°C). This shutdown requires a manual reset via the Reset push button on the Vyper™ logic board.

VSD High Phase B Inverter Baseplate Temp - A thermistor sensor is located inside the IGBT Module on the Vyper™ power unit. If at anytime this thermistor detects a temperature of 175°F (79°C) or higher of the Phase B Inverter, a shutdown will occur. The cooling fans and coolant pump on the Vyper™ will continue to run after the shutdown, until the thermistor temperature has dropped to below 165°F (74°C). This shutdown requires a manual reset via the Reset push button on the Vyper™ logic board.

VSD High Phase C Inverter Baseplate Temp - A thermistor sensor is located inside the IGBT Module on the Vyper™ power unit. If at anytime this thermistor detects a

temperature of 175°F (79°C) or higher of the Phase C Inverter, a shutdown will occur. The cooling fans and coolant pump on the Vyper™ will continue to run after the shutdown, until the thermistor temperature has dropped to below 165°F (74°C). This shutdown requires a manual reset via the Reset push button on the Vyper™ logic board.

VSD Initialization Fault - At power-up, all the boards go through a process called initialization. At this time, memory locations are cleared, jumper positions are checked, and serial communications links are established.

VSD Invalid Current Scale Selection - The J1 connector on the Vyper™ Logic board contains jumpers along with wires from the output CTs. Since the part number of the Logic board is the same on all horsepower sizes, the jumpers tell the logic board the size of the Vyper™ being employed in order to properly scale the output current. If the jumper configuration is found by the Logic board to be invalid, the system will be shut down and the above message will be generated.

VSD Logic Board Power Supply Fault - The various DC power supplies which power the Logic Board are monitored via hardware located on the Logic Board. If any of these power supplies fall outside their allowable limits, the unit will trip and the Quantum™ LX Panel will display the fault message.

VSD Logic Board Processor Fault - This shutdown is generated if a communications problem occurs between the two microprocessors on the Vyper™ Logic Board. If this shutdown occurs, replace the Vyper™ Logic board.

VSD Low Converter Heatsink Temp Fault - The phase bank assembly heatsink temperature and the inverter module base plate temperature are compared to a lower limit of 37°F. If the inverter base plate temperature or the converter heat sink temperature falls below 37°F, this message will be displayed. In addition, if both temperatures fall below the 37°F limit, the unit will trip and the fan(s) and water pump will be energized.

VSD Low DC Bus Voltage Fault - The DC link under voltage trip level must be set at 500 VDC for 60 Hz and 414 VDC for 50 Hz VSD's. If the DC link drops below this level, the unit will trip, and the Vyper™ Logic Board will initiate a system shutdown.

VSD Low Inverter Baseplate Temp Fault - The phase bank assembly heatsink temperature and the inverter module base plate temperature are compared to a lower limit of 37°F. If the inverter module base plate temperature falls below this limit the unit will trip and the Quantum™ LX Panel will display this message.

VSD Low Phase A Inverter Baseplate Temp. - The phase A heatsink temperature and the inverter module base plate temperature are compared to a lower limit of 37°F. If the inverter module base plate temperature falls below this limit the unit will trip and the Quantum™ LX Panel will display this message. In addition, if both the inverter and

converter temperatures fall below the 37°F limit, the unit will trip and the fan(s) and water pump will be energized.

VSD Low Phase B Inverter Baseplate Temp. - The phase B heatsink temperature and the inverter module base plate temperature are compared to a lower limit of 37°F. If the inverter module base plate temperature falls below this limit the unit will trip and the Quantum™ LX Panel will display this message. In addition, if both the inverter and converter temperatures fall below the 37°F limit, the unit will trip and the fan(s) and water pump will be energized.

VSD Low Phase C Inverter Baseplate Temp. - The phase C heatsink temperature and the inverter module base plate temperature are compared to a lower limit of 37°F. If the inverter module base plate temperature falls below this limit the unit will trip and the Quantum™ LX Panel will display this message. In addition, if both the inverter and converter temperatures fall below the 37°F limit, the unit will trip and the fan(s) and water pump will be energized.

VSD Phase A Gate Driver Fault - The unit's phase bank assembly shall contain one IGBT gate driver control board. This board monitors the saturation voltage drop across the Phase A Gate Driver while gated on. If the IGBT's Phase A Gate Driver saturation voltage exceeds the prescribed limit, the gate driver will make the determination that a short circuit is present. This in turn shall cause the unit to trip and the Quantum™ LX Panel shall display this message. If the driver board's power supply voltage falls below the permissible limit, this same message shall be generated.

VSD Phase B Gate Driver Fault - The unit's phase bank assembly shall contain one IGBT gate driver control board. This board monitors the saturation voltage drop across the Phase B Gate Driver while gated on. If the IGBT's Phase B Gate Driver saturation voltage exceeds the prescribed limit, the gate driver will make the determination that a short circuit is present. This in turn shall cause the unit to trip and the Quantum™ LX Panel shall display this message. If the driver board's power supply voltage falls below the permissible limit, this same message shall be generated.

VSD Phase C Gate Driver Fault - The unit's phase bank assembly shall contain one IGBT gate driver control board. This board monitors the saturation voltage drop across the Phase C Gate Driver while gated on. If the IGBT's Phase C Gate Driver saturation voltage exceeds the prescribed limit, the gate driver will make the determination that a short circuit is present. This in turn shall cause the unit to trip and the Quantum™ LX Panel shall display this message. If the driver board's power supply voltage falls below the permissible limit, this same message shall be generated.

VSD Precharge Lockout Fault - If the Vyper™ fails to meet the precharge criteria, then the precharge circuit will wait for a period of 10 seconds. During this time, the unit's cooling fans and coolant pump remain energized in order to cool the input SCR's. Following this 10-second cool-

down period, precharge will again be initiated. The unit will attempt to meet the precharge criteria three consecutive times. If the Vyper™ fails to meet the precharge criteria on three consecutive tries, the Vyper™ will shut down, lock out, and display this message. In order to initiate precharge again, the Quantum™ LX panel's compressor switch must first be placed into the STOP/RESET position.

VSD Precharge - DC Bus Voltage Imbalance - The 1/2 DC link voltage magnitude will remain within ± 88 VDC of the total DC link voltage divided by two during the precharge interval for both the 60 and 50 Hz VSD's. If not, the Quantum™ LX panel will display this message. The definition for this fault is identical to "VSD - DC Bus Voltage Imbalance", except that the fault has occurred during the precharge period which begins during prelude.

VSD Precharge - Low DC Bus Voltage 1 - The DC link voltage will reach at least 50 VDC within 100 msec after the precharge relay has been pulled in on the 60 Hz 519 filter and at least 41 VDC within 100 msec on the 50 Hz 519 filter. If not, the Quantum™ LX panel will display this message.

VSD Precharge - Low DC Bus Voltage 2 - The DC link voltage will reach at least 50 VDC within 100 msec after the precharge relay has been pulled in on the 60 Hz 519 filter and at least 41 VDC within 100 msec on the 50 Hz 519 filter. If not, the Quantum™ LX panel will display this message.

VSD Run Signal Fault - Upon receipt of either of the two run commands, a 5-second timer will start. If the missing run signal is not asserted within the 5-second window, the unit will trip and the Quantum™ LX panel will display this message.

VSD Serial Communication Fault - When requesting Status data, the response data from the Vyper™ includes a bit that indicates whether communications were lost from the Frick Interface Board to the Vyper™. If this bit is high for 22 consecutive seconds, this fault occurs. This fault also occurs whenever a receive, timeout, or checksum fault is detected on the Vyper™ communications, for twenty continuous seconds. While this fault is active, the Frick Interface Board will send Initialize data requests in order to reestablish the communications link. All serial input data is also cleared.

VSD Single Phase Input Power Fault - The Vyper's SCR Trigger Control board contains circuitry that checks the three-phase mains for the presence of all three line voltages. If all line voltages are not present, the unit will trip and the Quantum™ LX Panel will display this message.

VSD Stop Contacts Fault - This fault occurs if the No Fault signal from the Vyper™ is low. It indicates a fault is present at the Vyper™ or the Harmonic Filter, but the communications data contains no Vyper™ fault data for twenty seconds. The Frick Interface Board will send Initialize data requests while this fault is active.

VSD 105% Motor Current Overload Fault - The Vyper™ Logic Board generates this shutdown by reading the current from the 3 output current transformers. The shutdown is generated when the Vyper™ Logic board has detected that the highest of the three output phase currents has exceeded 105% of the programmed 100% full load amps (FLA) value for more than 40 seconds. If this is detected, the unit will trip and the Quantum™ LX panel will display the fault message.

APPENDIX A

QUANTUM™ LX PANEL SOFTWARE UPDATE PROCEDURE

This procedure covers updating *from version 6.06 or below to version 6.07 or above.*

1. Stop the compressor.
2. With power ON, insert the USB device into port PL8 USB. Ensure that the tabbed key of the drive connector is plugged in as shown in Figure 1 of this section.
3. Go to User Level 2. The default password is 20.
4. Press the **[Menu]** key.
5. Cursor down to *Service...* and press the **[Enter]** key.
6. Cursor down to *Software Maintenance* and press the **[Enter]** key.
7. Press **[2]** to *Save Setpoints*.
8. Press **[1]** to do a *Full System Install*.
9. Press **[3]** to *Restore Setpoints*.
10. While leaving the USB device plugged in, press **[4]** to *Exit*.
11. During the reboot of the Quantum™ LX, a message will appear that says, "A System Update file has been detected on the mounted USB device. Do you wish to perform this update?" Select **[Yes]**, and a System Update will be performed.
12. At the conclusion of the System Update, a message will appear that says, "The USB device can now be removed and power should be recycled." Follow these instructions.

This procedure covers updating *from version 6.07 or above.*

1. Stop the compressor.
2. With power ON, insert the USB device into port PL8 USB. Ensure that the tabbed key of the drive connector is plugged in as shown in Figure 1 of this section.
3. Go to User Level 2. The default password is 20.
4. Press the **[Menu]** key.
5. Cursor down to *Service...* and press the **[Enter]** key.
6. Cursor down to *Software Maintenance* and press the **[Enter]** key.
7. Press **[1]** to *Save Setpoints*.
8. Press **[2]** to do a *Full System Install*.
9. Press **[3]** to *Restore Setpoints*.
10. While leaving the USB device plugged in, press **[4]** to *Exit*.
11. During the reboot of the Quantum™ LX, a message will appear that says, "A System Update file has been detected on the mounted USB device. Do you wish to perform this update?" Select **[Yes]**, and a System Update will be performed.
12. At the conclusion of the System Update, a message will appear that says, "The USB device can now be removed and power should be recycled." Follow these instructions.

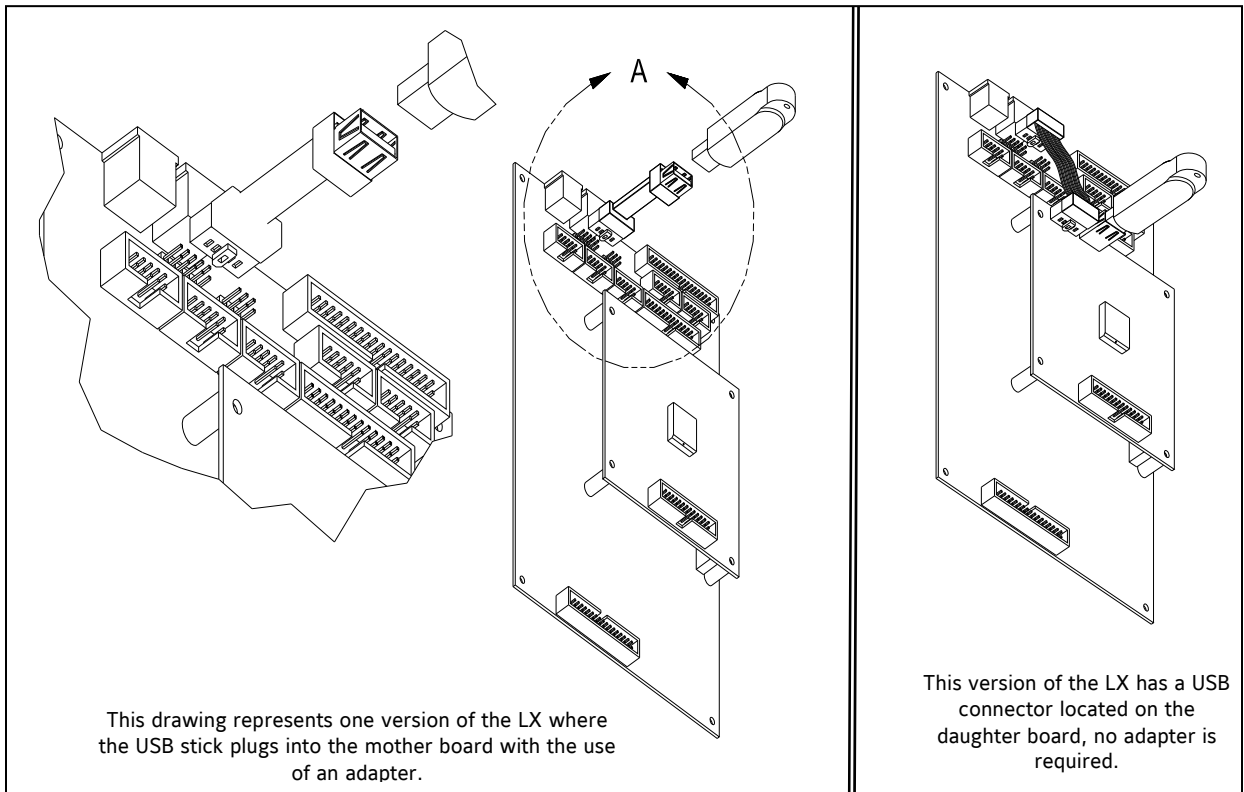

USB Memory Stick Plug-in locations

APPENDIX B

OIL SAFETY LOGIC

Part 1: Missing Oil Pressure

No Pump or Demand Pump

(All pressure calculations are in PSIA)

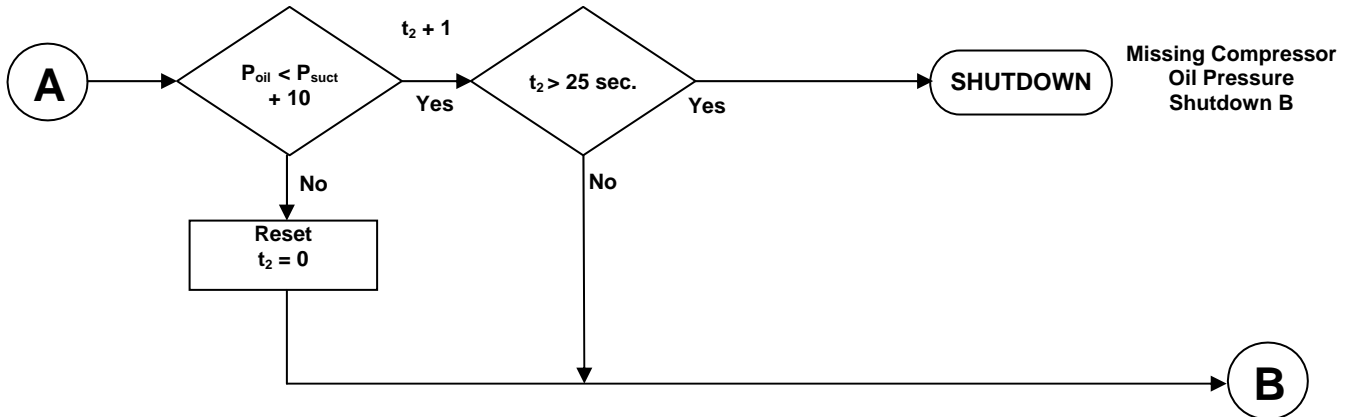
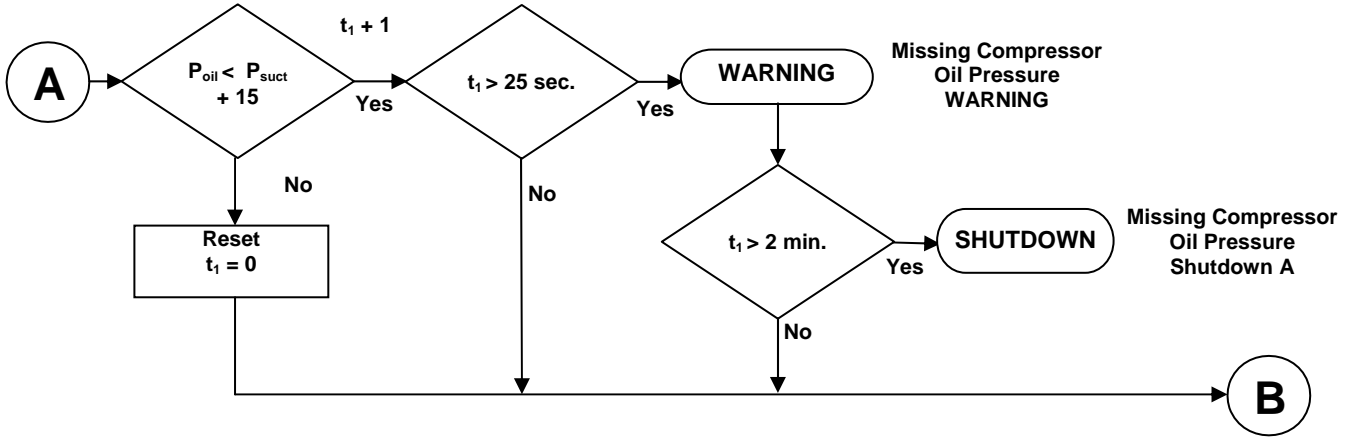

OIL SAFETY LOGIC

Part 2: Insufficient Main Oil Pressure During Low Differential

No Pump or Demand Pump

(All pressure calculations are in PSIA)

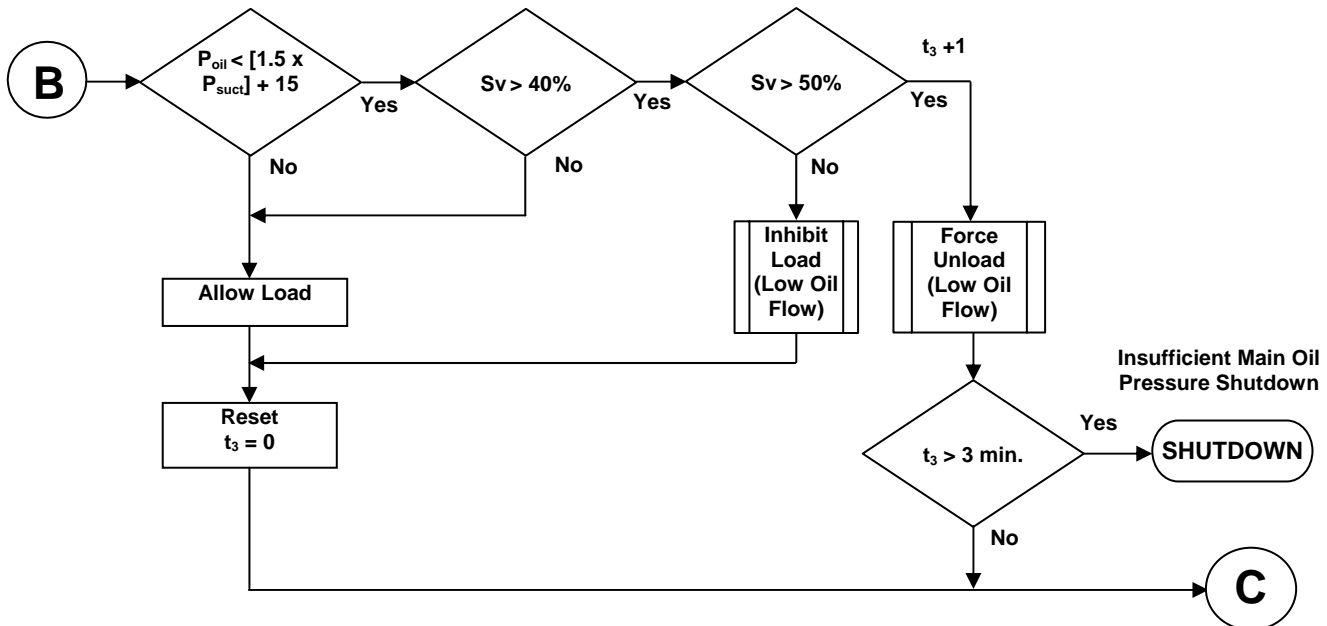

OIL SAFETY LOGIC
Part 3: Oil Circuit Pressure Drop
No Pump or Demand Pump
(All pressure calculations are in PSIA)

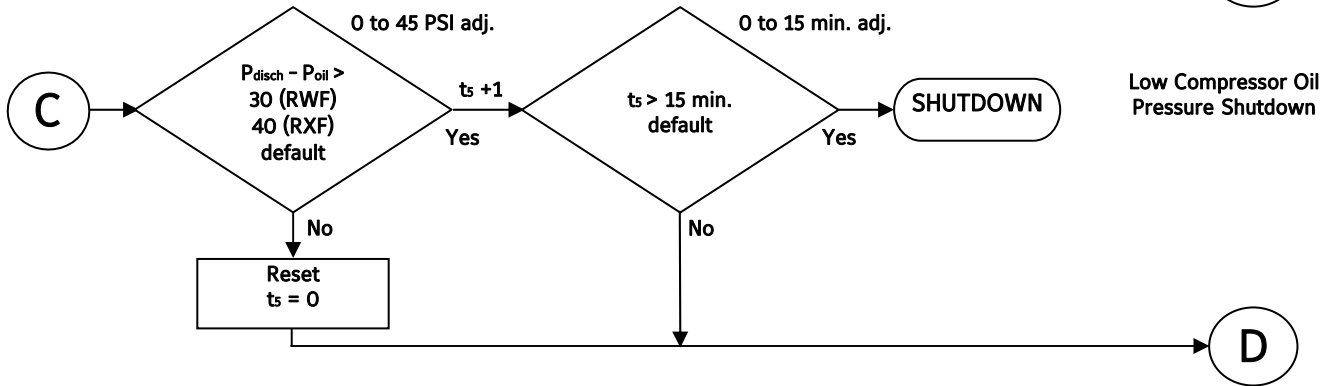
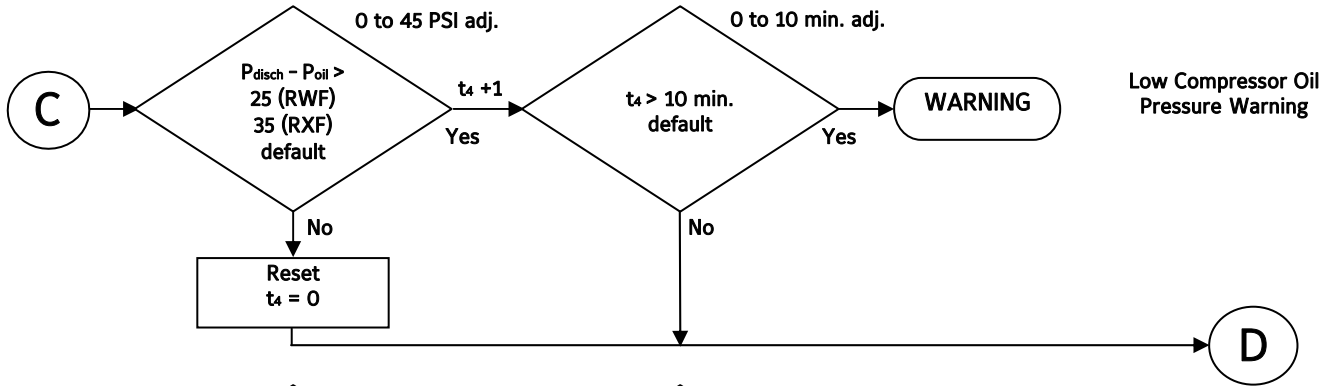

Full Time Pump (Frick Compressor Only)
(All pressure calculations are in PSIA)

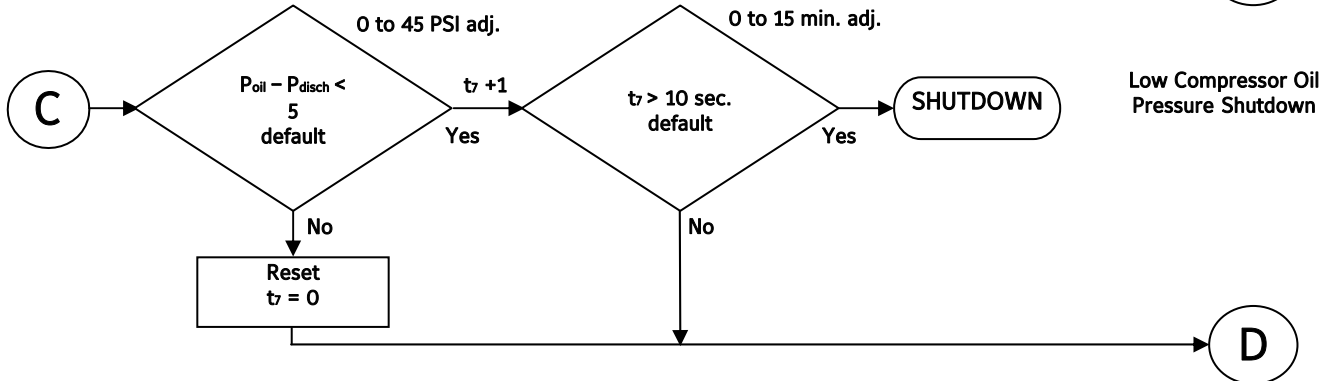
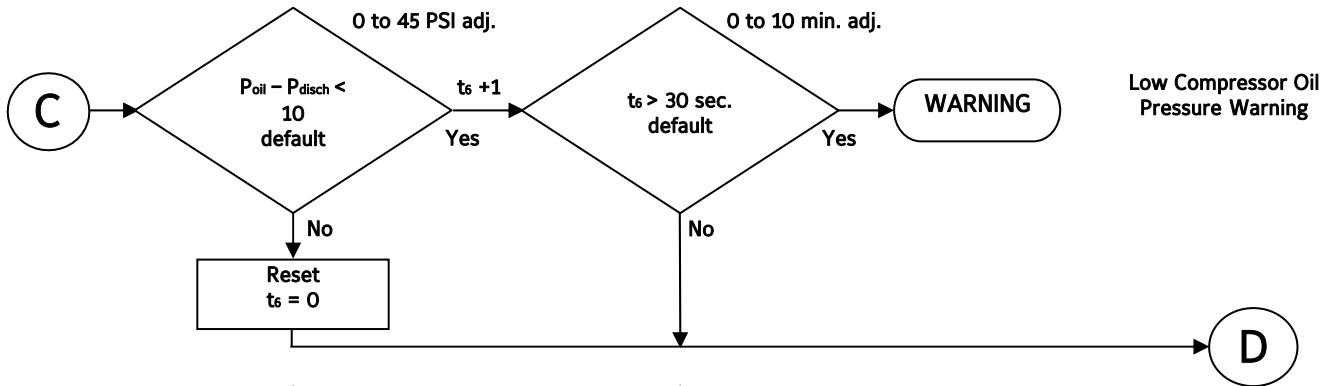

OIL SAFETY LOGIC

Part 4: Oil Pressure Filter Drop

Filter Selection: Filter – Oil
(All pressure calculations are in PSIA)

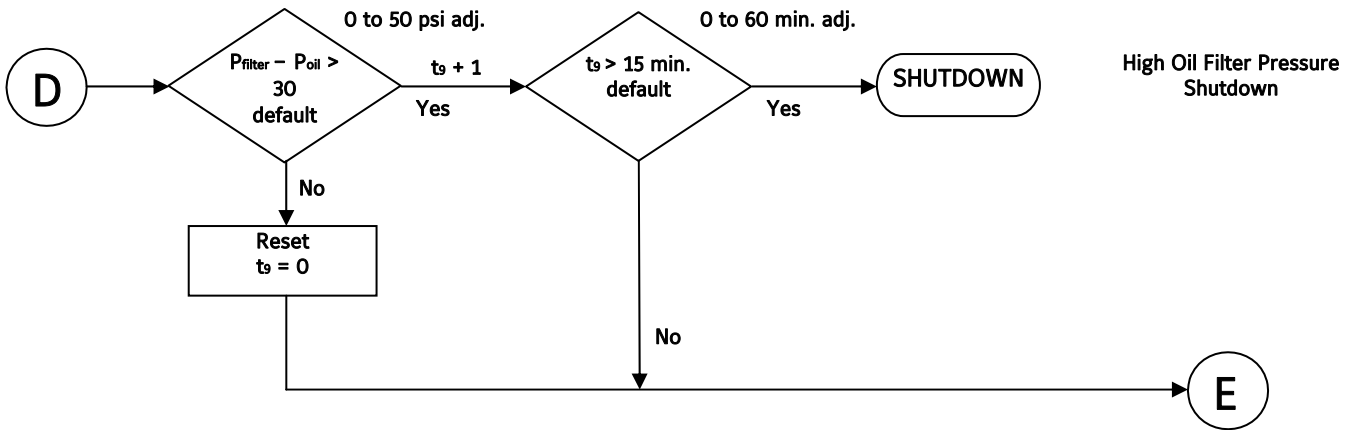
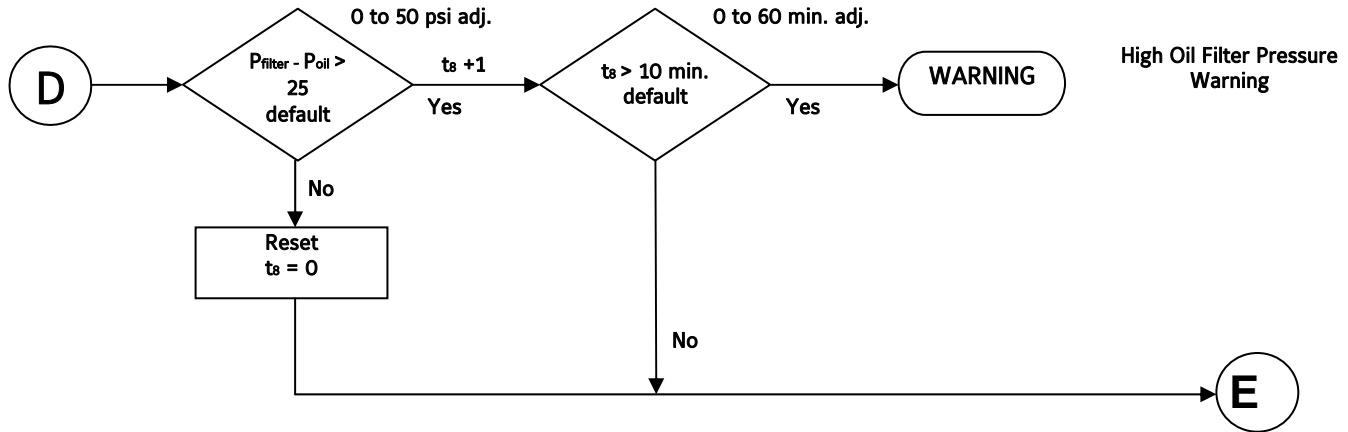

Note: Only when filter pressure transducer is available

OIL PUMP STARTING LOGIC No Pump

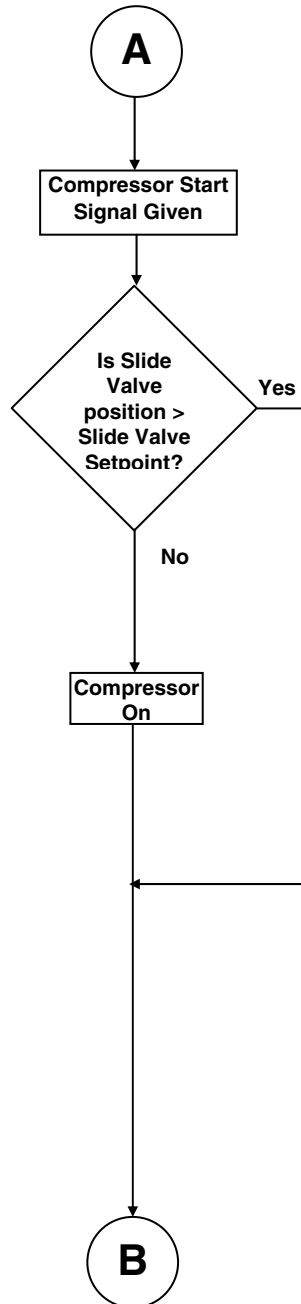
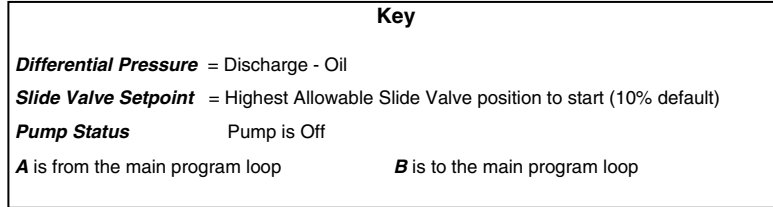

OIL PUMP STARTING LOGIC

Demand Pump

(All pressure calculations are in PSIA)

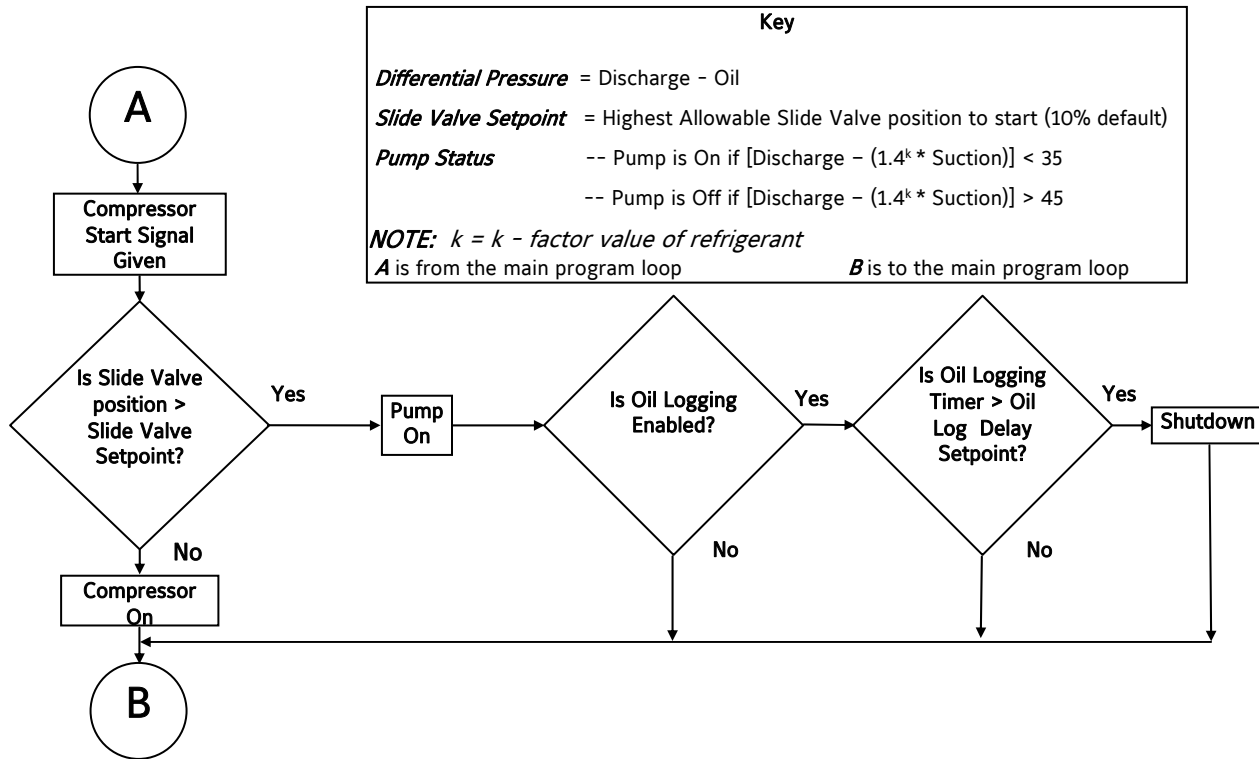

OIL PUMP RUNNING LOGIC

Demand Pump

(All pressure calculations are in PSIA)

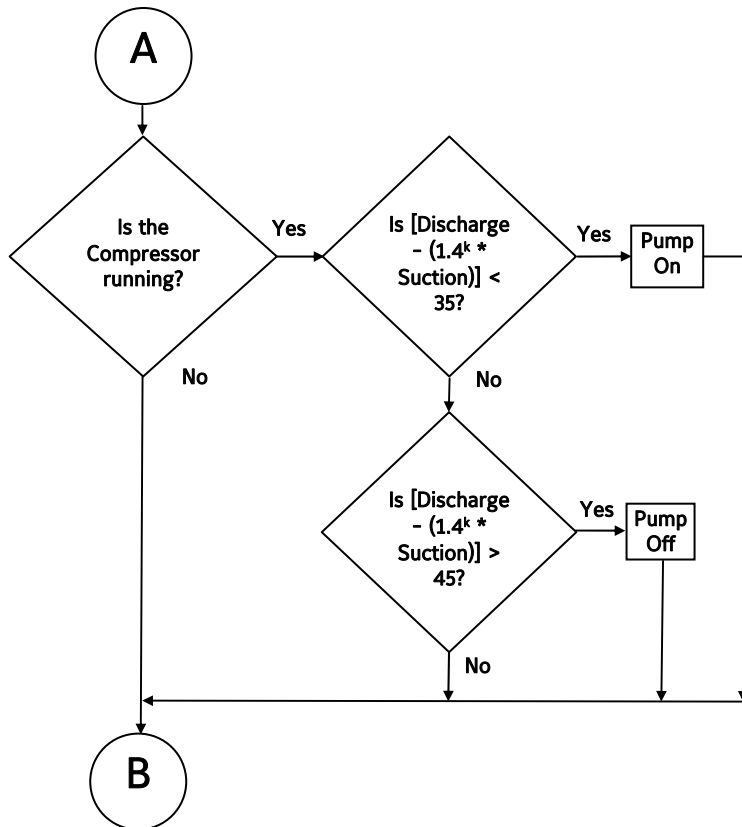

INDEX

A	
About	3, 80
Active Mode	14, 17
Alpha	81
Analog Boards	80
ASCII	67, 83
Autocycle	12, 13, 29, 82
Automatic	3, 10, 11, 14, 17, 28, 31, 32, 54, 82, 83
Auxiliaries	49, 51, 52
Auxiliary	3, 15, 44, 45, 47, 49-52, 60, 62-64, 82, 84, 86, 89, 92
B	
Balance Piston ...	11, 15, 20, 28, 32, 44, 47, 52, 60, 64, 84, 86, 89
Baud Rate	66
Board Type	80
Booster	14, 30
C	
Capacity	2, 3, 6, 9-15, 17, 20, 28, 29, 31, 32, 34, 35, 38, 44, 52-54, 57, 60, 64, 83, 84, 89, 91
Capacity Control	28
Capacity Slide Position	15
Channel2	15, 20, 28, 29, 45, 47, 51, 52, 58, 60, 61, 63, 64, 83
Communications	3, 9, 14, 66, 69, 73, 76, 83, 84, 85
Compressor Configuration	14, 82
Compressor ID	66
Compressor Mode	10, 12, 13, 31, 32, 53, 83
Compressor Model	9
Condenser	2, 38, 40, 41, 64, 65, 82
Control Inputs	14
Control Setpoint	13, 14, 40, 41, 44-48, 54, 58, 83
D	
Data Bits	66
Date	9
Date Format	71
DBS	36, 65, 67, 84
DHCP	68
Diagnostics	3, 76
Digital Boards	80
Discharge Pressure ..	11, 15, 20, 28, 29, 31, 32, 40, 41, 44, 47, 52, 60, 64, 84, 86, 87, 89, 90, 92
Discharge Temperature .	11, 15, 20, 28, 31, 35, 38, 44, 45, 47, 52, 60, 64, 87, 89, 90
Documentation	3, 79
Drive Controller	80
E	
Economizer Pressure	15, 20, 28, 44, 47, 52, 60, 64, 87, 90
Email	68, 69
Energy Savings	2, 27
Enter	6, 7
Ethernet	3, 14, 68, 70, 78
Event Log	2, 25, 26, 86, 89, 92
Exit	7, 78, 96
EZ Cool	15, 20, 28, 44, 47, 52, 60, 64
F	
Filter Differential	11, 78, 84
Filter Pressure ...	15, 20, 28, 34, 44, 47, 52, 55, 60, 64, 87, 88, 90
Fixed	32, 68
G	
Gateway Address	68
H	
Help	3, 7, 79
High Limit	41, 45, 48, 87
High Stage	12, 13, 14, 30
High Stage/Booster	14
Home	9, 15
Hot Gas Bypass	83
I	
Integration Time	41, 45, 46, 48
Intermediate Pressure	15, 20, 28, 44, 47, 52, 60, 64
IO Boards	80
IP address	14, 68
K	
Keyboard	7
Keypad	4, 5, 7, 10, 18, 19, 25, 26, 54, 69, 77-79, 81, 84
L	
LAN	30, 68, 69
Language	71
Level 0	69, 71
Level 1	69, 71
Level 2	69, 71
Linux Kernel	80
Loop Back Test	3, 76
Low Limit	41, 45, 48
Low Suction	29
M	
Maintenance	2, 25, 26, 81

Manifold Pressure15, 20, 29, 44, 47, 52, 60, 65, 87, 90
 Manual5, 7, 10, 11, 17, 31, 69, 76, 82, 83
 Map File 67
 Master12, 13, 14, 30, 31
 Menu 6, 7, 14, 22, 45, 79, 86, 87, 89, 90, 91, 96
 Minimum Capacity13, 14
 Minimum Runtime 14
 ModBus 74
 Mode Safeties 29
 Motor Amps 10, 36, 37, 58, 85, 87, 90, 92
 Motor Bump 75
 Motor Current15, 20, 28, 29, 44, 52, 60, 64, 82, 85, 87, 90, 92, 95
 Mouse 7

N

Network7, 30, 68, 69

O

Oil Heater 10, 38
 Oil Pressure ... 3, 11, 15, 20, 28, 34, 38, 44, 47, 52, 60, 64, 82, 84, 86, 88-90, 92, 97, 99
 Oil Pump 10, 17, 34, 82, 85, 92
 Oil Temperature 10, 11, 15, 20, 28, 33, 44, 47, 52, 60, 64, 86, 88, 90, 91
 OK7, 78
 Operating Status 2, 9, 15, 18, 19, 45, 78, 82, 83
 Output 32, 37, 41, 45-48, 52, 53, 61, 62, 93

P

Panel Heater 53
 Panel Temperature 53
 Parity 66
 Password70, 71
 PLC Interlock 54
 Pressure 2, 3, 12, 13, 15, 20, 28, 31, 32, 34, 40, 44, 47, 48, 52, 55, 60, 63, 64, 71, 82, 84, 86-92, 98
 Pressure Units 71
 Process Temperature11, 29, 89, 91
 Proportional Band13, 28, 41, 45, 46, 48
 Protocol67, 69

Q

Quantum™ LX 2, 4, 8, 9, 17, 39, 56, 61, 66-69, 73, 78, 80, 85, 86, 92-96

R

Recycle Delay10, 11, 36, 82, 83
 Refresh Button 7
 Remote -- Communications10, 17
 Remote -- IO 10, 11, 17
 Remote -- Sequencing 10, 11, 17
 Remote Internet Access 70

Remote Load 82
 Remote Unload 83
 RPM 15, 20, 28, 44, 52, 57, 59, 60, 64, 89, 91
 Run Hours 25, 54

S

Sales Order80
 Scheduling 39
 Screen Title 9
 Security 3, 69
 Separator Temperature. 11, 15, 20, 28, 33, 38, 44, 47, 52, 56, 60, 64, 84, 88, 89, 91
 Sequencing2, 12, 13, 14, 30, 64, 78
 Session3, 14, 71
 Setpoint .. 4, 6, 7, 10, 13, 14, 28-30, 32, 35, 37-39, 45, 46, 48-50, 53, 54, 66, 71, 75-79, 82, 83, 86-91, 96
 Setpoint Box 7, 30, 56, 58, 68, 69, 75
 Shutdown 10, 11, 18, 19, 29, 31-34, 37, 38, 42, 43, 49-51, 68, 84-92
 Slide Valve10, 11, 14, 27, 28, 31, 32, 34, 36, 38, 54, 57, 78, 82-85, 89, 92
 SMTP 69
 Software Maintenance 3, 7, 77, 78, 96
 Software Version80
 Start3, 5, 7, 11, 12, 14, 29-31, 53, 57, 78, 82, 92
 Start Delay12, 29
 Start Procedure 12
 Start Refresh 7
 Start Status 11
 Start/Stop 12
 Stop5, 7, 13, 29, 36, 57, 66, 82, 83, 95, 96
 Stop Bits 66
 Stop Delay13, 29
 Stop Refresh 7
 Submit 6, 7, 14, 51, 62
 Subnet Mask 68
 Suction Pressure 11-13, 15, 20, 28, 29, 32, 34, 44, 47, 52, 55, 60, 64, 84, 89-92
 Suction Temperature 11, 15, 20, 28, 44, 47, 52, 56, 58, 60, 64, 89
 Superheat 2, 11, 47, 48

T

TCP 3, 74
 Temperature 2, 4, 9-11, 15, 20, 28, 29, 33, 38, 39, 42-44, 47, 48, 52, 53, 55, 56, 58, 60-65, 71, 84-91, 93, 94
 Temperature Units 71
 Time 9
 Trending 2, 20-24

U

User Level 14, 68, 71, 96
 User Name 70

V

Volume.....2, 10, 15, 17, 20, 28, 32, 44, 52, 57, 60, 64
VSD 2, 27, 84, 86, 92-95
Vyper.....2, 16, 65, 84-86, 92-95

W

Warning...10, 18, 19, 29, 31-34, 36-38, 42, 43, 49-51,
84, 86-92
Web Browser.....7, 69, 79
Web Server Port..... 68