

# VELAN

## PROQUIP®

### Dual Plate Check Valves

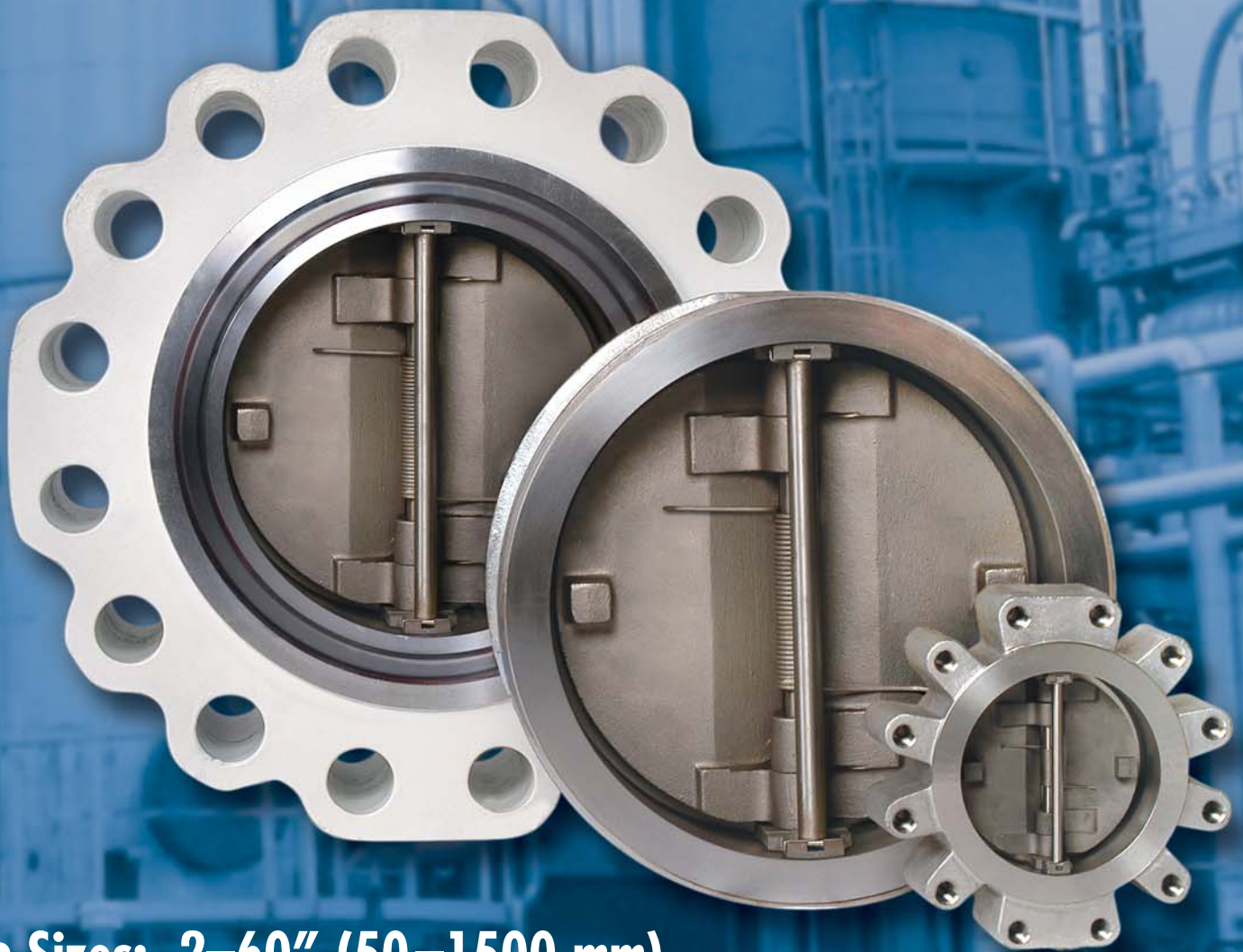

- Sizes: 2–60" (50–1500 mm)
- ASME Classes: 150–2500 • API: 2000–5000

**Retainerless Design for Fugitive Emission Control**

# VELAN'S COMPANY PROFILE

Velan is one of the world's leading manufacturers of industrial steel valves, supplying gate, globe, check, ball, butterfly and knife gate valves for critical applications in the chemical, petrochemical, oil and gas, fossil and nuclear power, cogeneration, pulp and paper and cryogenic industries. See the back cover of this catalog for a summary of the many quality products that Velan designs and manufactures.

Founded in 1950, Velan earned a reputation for excellence as a major supplier of forged valves for nuclear power plants and the U.S. Navy. Velan Inc. pioneered many designs which became industry standards, including bellows seal valves, all stainless steel knife gate valves and forged valves up to 24".

Velan valves are manufactured in 12 specialized manufacturing plants, including five in Canada and U.S.A., four in Europe and three in Asia. We have a total of over 1,500 employees, 75% of whom are located in our North American operations.

Velan's Proquip Dual Plate Check Valves are high quality valves built for long, reliable service life in critical services. From offshore oil platforms, to nuclear power plants, to petroleum refineries, leading construction/engineering firms and industrial end user companies rely on Proquip Dual Plate Check Valves to keep their operations running smoothly. The wide product line extends from valves for cryogenics to high temperatures and pressures (ASME 2500), standard to specialty materials (monel, inconel, titanium) and sizes up to 60".

## CONTENTS

Velan's Global Network .....	1
Manufacturing Program .....	2
Application Industries .....	3
Total Quality & Process Improvement... ..	4
Engineered Solutions .....	5
Design Features .....	6-8
Standard Materials & Specifications ... ..	9
Wafer Type PW Valves.....	10-13
Lug Type PL & PM Valves .....	14-16
Flanged Type PF & PG Valves .....	17-18
Hub Type PH Valves.....	19
Special Services .....	20
Engineering Data.....	21-22
Specification of Valve Materials and Bolt Circle Diameter Data .....	23
Installation/Service .....	24
How to Order .....	25

## HEAD OFFICE & PLANT 5



**MONTREAL, CANADA** 115,000 sq. ft. (10,683 m<sup>2</sup>)  
2-60" (50-1500 mm) dual plate check valves, 3-48" (80-1200 mm) triple-offset butterfly valves,  
3/8-2" (10-50 mm) metal & resilient seated ball valves

## MANUFACTURING LOCATIONS

### CANADA

#### VELAN INC. HEAD OFFICE & PLANT 5

7007 Côte de Liesse  
Montreal, QC H4T 1G2  
Tel: (514) 748-7743  
Fax: (514) 748-8635

#### PLANT 1

2125 Ward Avenue  
Montreal, QC H4M 1T6  
Tel: (514) 748-7743  
Fax: (514) 748-8635

#### PLANT 2 / 7

550 McArthur Ave.  
Montreal, QC H4T 1X8  
Tel: (514) 748-7743  
Fax: (514) 341-3032

#### PLANT 4 / 6

1010 Cowie Street  
Granby, QC J2J 1E7  
Tel: (450) 378-2305  
Fax: (450) 378-6865

### U.S.A.

#### VELAN VALVE CORPORATION PLANT 3

94 Avenue C  
Williston, VT 05495-9732  
Tel: (802) 863-2562  
Fax: (802) 862-4014

### ENGLAND

#### VELAN VALVES LTD.

Unit 1, Pinfold Road  
Lakeside Business Park  
Thurmaston  
Leicester LE4 8AS  
Tel: 44-116 269-5172  
Fax: 44-116 269-3695

### ITALY

#### VELAN SRL

Via Delle Industrie 9/5  
20050 Mezzago,  
Tel: (39) 039 624-1101  
Fax: (39) 039 688-3357

### FRANCE

#### VELAN S.A.S

90, rue Challemeil Lacour  
F 69 367 Lyon Cedex 7  
Tel: (33) 4 78 61 67 00  
Fax: (33) 4 78 72 12 18

### PORTUGAL

#### VELAN VÁLVULAS INDUSTRIAIS, LDA.

Av. Ary dos Santos  
1679-018 Famosos  
Tel: (351-21) 934-7800  
Fax: (351-21) 934-7809

### TAIWAN

#### VELAN-VALVAC

P.O. Box 2020  
Taichung, Taiwan  
R.O.C.  
Tel: (04) 2792649  
Fax: (886) 42750855

### KOREA

#### VELAN LTD.

1060-4 Shingil-Dong  
Ansan City,  
Kyunggi-do 425-833  
Tel: (82) 31-491-2811  
Fax: (82) 31-491-2813

## DISTRIBUTION CENTERS

### U.S.A.

#### VELCAL

537 Stone Road, Unit "A"  
Benicia, CA 94510  
Tel: (707) 745-4507  
Fax: (707) 745-4708

#### VELEAST

605 Commerce  
Park Drive SE  
Marietta, GA 30060  
Tel: (770) 420-2010  
Fax: (770) 420-7063

#### VELNORTH

94 Avenue C  
Williston, VT 05495-9732  
Tel: (802) 651-0867  
Fax: (802) 865-3030

### ENGLAND

#### VELAN VALVES LTD.

Unit 1, Pinfold Road  
Lakeside Business Park  
Thurmaston  
Leicester LE4 8AS  
Tel: 44-116 269-5172  
Fax: 44-116 269-3695

### GERMANY

#### VELAN GmbH

Daimlerstrasse 8  
D-47877 Willich  
Tel: (49) 2154-4938-0  
Fax: (49) 2154-4938-99

Velan has sales offices & distributors located worldwide.

Visit the Velan website at [www.velan.com](http://www.velan.com)  
for an updated contact list.

## GENERAL INFORMATION

Tel: (514) 748-7743 Fax: (514) 748-7592  
[sales@velan.com](mailto:sales@velan.com)

**NOTE:** The material in this catalog is for general information. For specific performance data and proper material selection, consult your Velan representative. Although every attempt has been made to ensure that the information contained in this catalog is correct, Velan reserves the right to change designs, materials or specifications without notice.

# VELAN'S GLOBAL NETWORK



**Plant 1**  
**MONTREAL, CANADA**  
 109,000 sq. ft. (10,126 m<sup>2</sup>),  
 ¼–4" (8–100 mm) forged gate, globe  
 & check valves



**Plant**  
**LYON, FRANCE - Velan S.A.S**  
 160,000 sq. ft. (14,900 m<sup>2</sup>)  
 ¼–42" (8–1,050 mm) forged & cast steel  
 gate, globe and butterfly valves



**Plant**  
**MILAN, ITALY - Velan SRL**  
 93,000 sq. ft. (8,400 m<sup>2</sup>)  
 1–64" (25–1600 mm) API 6D & 6A  
 trunnion mounted ball valves



**Plant 2 & 7**  
**MONTREAL, CANADA**  
 170,000 sq. ft. (15,800 m<sup>2</sup>),  
 2–60" (50–1500 mm) forged & cast steel  
 gate, globe, check, ball, knife and  
 3–36" (80–700 mm) butterfly valves



**Distribution Center**  
**LEICESTER, ENGLAND - Velan Valves Ltd**  
 14,000 sq. ft. (1,300 m<sup>2</sup>)  
 steam traps, ¾–2" (10–50 mm)  
 bonnetless globe valves



**Distribution Center**  
**WILLICH, GERMANY - Velan GmbH**  
 12,000 sq. ft. (1,115 m<sup>2</sup>)



**Plant 3** **Distribution Center**  
**WILLISTON, VT, U.S.A. - Velan Valve Corp.**  
 155,000 sq. ft. (14,400 m<sup>2</sup>)  
 2–24" (50–600 mm) forged & cast steel  
 gate, globe and check valves  
 - **VELNORTH** 8,000 sq. ft. (743 m<sup>2</sup>)

- 12 Manufacturing Plants
- 5 Stocking Distribution Centers
- 27 Sales Offices
- Over 200 Distributors in over 500 locations
- Over 70 Service Shops



**Plant**  
**ANSAN CITY, SOUTH KOREA Plant 1**  
 30,000 sq. ft. (2,800 m<sup>2</sup>)  
 components and 2–4" (50–100 mm)  
 cast steel valves



**Plant 4 & 6**  
**GRANBY, CANADA**  
 186,500 sq. ft. (17,325 m<sup>2</sup>),  
 2–16" (50–400 mm) cast steel  
 gate, globe and check valves,  
 ¼–12" (8–300 mm) ball valves



**Plant**  
**LISBON, PORTUGAL**  
 60,000 sq. ft. (5,600 m<sup>2</sup>)  
 2–12" (50–300 mm) cast steel gate,  
 globe & check valves



**Plant**  
**ANSAN CITY, SOUTH KOREA Plant 2**  
 65,000 sq. ft. (5,800 m<sup>2</sup>), 2–12" (50–300 mm)  
 cast steel gate, globe, check, ball and  
 knife gate valves



**Distribution Center**  
**MARIETTA, GA, U.S.A. - VELEAST**  
 6,500 sq. ft. (600 m<sup>2</sup>)



**Distribution Center**  
**BENICIA, CA, U.S.A. - VELCAL**  
 15,000 sq. ft. (1,400 m<sup>2</sup>)



**Plant**  
**TAICHUNG, TAIWAN - Velan-Valvac**  
 20,000 sq. ft. (1,840 m<sup>2</sup>)  
 ¼–2" (8–50 mm) ball valves

# MANUFACTURING PROGRAM

## STANDARD PRODUCTION RANGE

For valve sizes, ASME Classes and designs not shown below, please consult Velan's Engineering Department.

### WAFER TYPE - PW

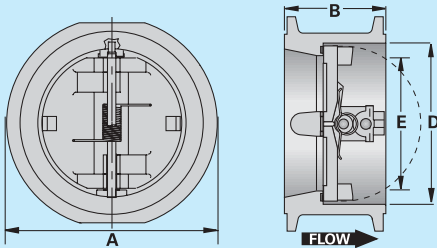

ASME CLASS					
150	300	600	900	1500	2500
2-60" (50-1500 mm)	2-60" (50-1500 mm)	2-60" (50-1500 mm)	2-48" (50-1200 mm)	2-24" (50-600 mm)	2-12" (50-300 mm)

API		
2000	3000	5000
2 1/16-20 3/4"	2 1/16-20 3/4"	2 1/16-11"

### LUG TYPE - PL & PM

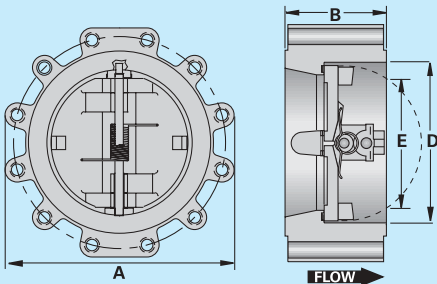

ASME CLASS					
150	300	600	900	1500	2500
2-60" (50-1500 mm)	2-60" (50-1500 mm)	2-60" (50-1500 mm)	2-48" (50-1200 mm)	2-24" (50-600 mm)	2-12" (50-300 mm)

### FLANGED TYPE - PF & PG

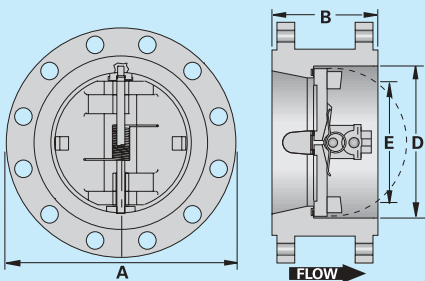

ASME CLASS			
150	300	600	900
12-60" (300-1500 mm)	12-60" (300-1500 mm)	12-60" (300-1500 mm)	12-48" (300-1200 mm)

### HUB END TYPE - PH

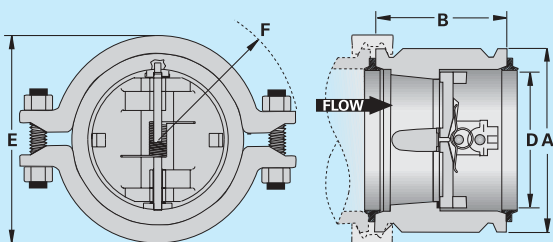

ASME CLASS			
600	900	1500	2500
2-12" (50-300 mm)	2-12" (50-300 mm)	2-12" (50-300 mm)	2-12" (50-300 mm)

# APPLICATIONS IN MAJOR INDUSTRIES

All over the world, Velan valves are used by the world's leading industrial companies to help keep their operating facilities running smoothly. In fact, Velan valves have a long history of proving themselves in many of the industrial world's toughest applications.



**Fossil, Nuclear & Cogeneration Power**



**Pulp & Paper**



**Refining**



**Mining**



**Marine**



**LNG & Cryogenics**



**Petrochemicals**



**Offshore**

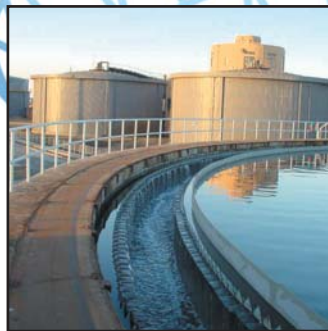

**Water & Wastewater**



**Chemical**



# TOTAL QUALITY & PROCESS IMPROVEMENT



## ▼ Total Quality Commitment ▼

Velan Total Quality Program

*Our aim is to offer products and services which not only meet, but clearly exceed, the expectations of our customers.*

*Through training, teamwork and performance, our employees strive to achieve continuous improvement of all processes.*

*Our goal is Total Quality and On-Time Delivery; our method is Total Commitment.*

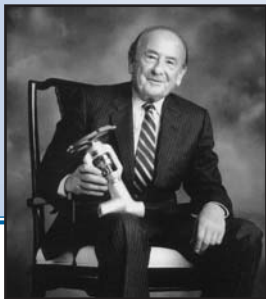

*A.K. Velan*

**A.K. Velan,  
Founder and C.E.O.**

Velan's number one priority is quality. From order entry to design engineering to the shop floor, the entire company is totally committed to offering products and services that not only meet, but exceed customer expectations. All Velan valves are designed and manufactured with an emphasis on low emissions, safety, simple maintenance, ease of operation, and above all, long and reliable service life.

## TOTAL PROCESS IMPROVEMENT

While Velan has always made quality a priority, in 1990 the company adopted a formal Total Quality Management Program, aimed at improving production processes and was awarded ISO 9001 status the following year.

Today, Velan's Total Process Improvement Program brings together a group of industry best practices, including Lean Manufacturing and Six-Sigma, with the goal of creating a more balanced and efficient production system.

## CERTIFICATES/APPROVALS

Velan holds all major applicable approvals, including ISO 9001:2000, PED, ASME N/NPT, TÜV, and TA-Luft. Velan's comprehensive quality program is fully compliant with the most stringent industry standards and has been surveyed and audited by leading organizations, regulatory bodies, utilities and architect/engineers from around the world.



## TOTAL PROCESS IMPROVEMENT PROGRAM:

- Total Quality Management Program (since 1990)
- Lean Manufacturing
- Six-Sigma

## CERTIFICATIONS/APPROVALS:

- ISO 9001:2000 (since 1991)
- PED
- ASME N and NPT (since 1970)
- AD2000-Merkblatt HP 0 and A4/TRD 110
- TA-Luft
- QA Program fully compliant with NCA 4000, ASME NQA-1 and 10 CFR 50 Appendix B
- Quality Programs surveyed by ASME and audited by NUPIC, Northrop Grumman Newport News, DCMA, utilities, architect/engineers and other organizations from around the world

# ENGINEERED SOLUTIONS

Velan's Engineering Design and Applications Group is comprised of approximately 50 professional engineers with extensive experience in critical applications across a broad range of industries. Equipped with advanced software applications, including finite element analysis (FEA), computational fluid dynamics (CFD) and 3D solid modeling, Velan engineers design superior quality valves that meet the most demanding performance requirements. Velan's R&D facilities, equipped with steam boilers and superheaters, flow loops and cryogenic test stands, provide the company with extensive testing capabilities.

Whether we are refining the design of our standard valves, or engineering valves to meet the demands of a specific application, Velan's vast engineering resources can handle the task. In fact, Velan has a long history of partnering with major architect/engineers, electric utilities and other end users to develop innovative solutions for their valving needs.

Velan's production machinery and equipment are specially engineered to meet the requirements of advanced large valve manufacturing. This includes large CNC horizontal and vertical boring mills with tool changers, CNC lathes and CNC machining centers. Over 150 CNC machines are in operation in Velan's North American plants.

All welding techniques employed at Velan are in accordance with qualified welding procedures for SMAW, GTAW, GMAW, PTAW and SAW processes.

Production testing equipment is designed to safely and efficiently test high and low pressure valves in strict accordance with industry codes and standards, as well as customer imposed criteria.

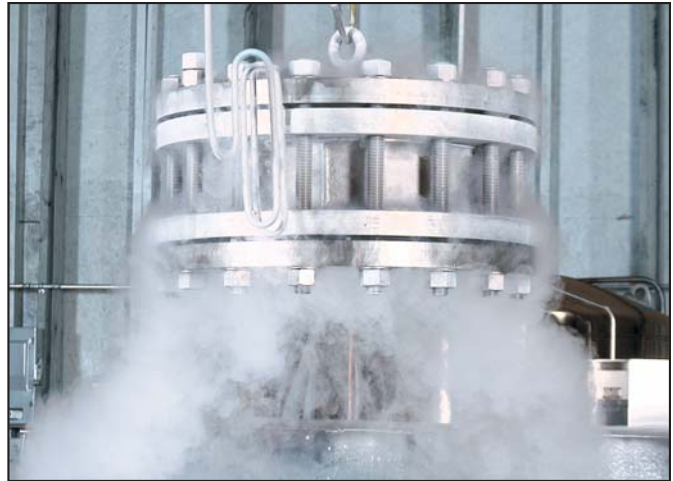

*A PF24-013D10-3DB is lifted from a cryogenic testing tank.*



*A robotic welding system applies a Stellite deposit onto a 10" Class 150 Wafer Type PW body seat with GMAW process.*

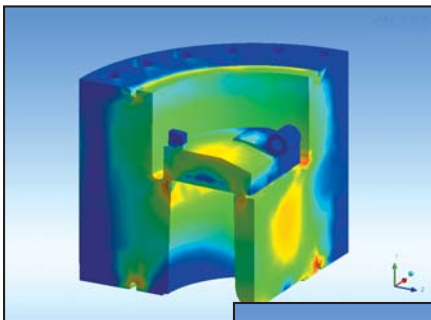

*FEA used to plot stress intensity and total deformation.*

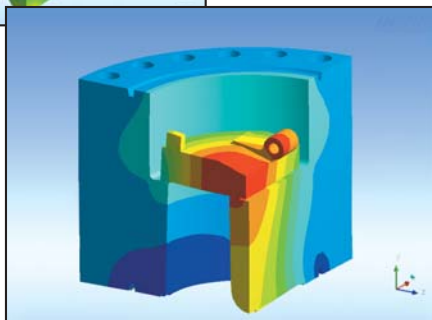

*A vertical work station with live spindle, working on a 36" Class 300 Double Flanged Type PF valve body, allows for turning, milling, drilling and tapping operations as applicable in one set-up.*

# SUPERIOR PERFORMANCE OF THE

## THE ADVANTAGES OF DUAL PLATE CHECK VALVES VERSUS SWING CHECK VALVES

### COST SAVING DESIGN

The inherent design of the dual plate check valve results in significantly reduced weight when compared to conventional full-bodied swing check valves. As valves increase in size the dual plate check valves can be as little as one fifth the weight of the equivalent full-bodied unit. This results in savings in initial cost, space and pipe support element installation.

### REDUCED LINE SHOCK

To minimize or eliminate line shock, check valves must close as quickly as possible prior to the flow having an opportunity to reverse. As each of the discs in dual plate check valves are only half the size of that of a full bodied check, they experience reduced fluid drag and can move more quickly to the closed position. Their swing radius is one half that of the conventional check valves. The leading edge distance from open to closed position is halved, in turn reducing the travel time by 50%.

The reduced weight of a dual plate valve disc versus the full bodied swing check is a major factor in minimizing slamming and water hammer. The heavier full bodied disc has greater momentum when swinging closed, causing it to slam into the valve seat (in large valve sizes the disc can weigh up to a ton).

### LOWER PRESSURE DROP AND INCREASED $C_v$ FOR VALVES 24" AND LARGER

The two factors that affect pressure drop across any valve are:

- 1) The unobstructed flow area.
- 2) The energy required to maintain the valve in the open position. Specifically, full-bodied swing check valves have a disc which is hinged at the top with gravity working to keep it in the closed position. Flow must provide sufficient energy to overcome this force of gravity and lift the disc. This energy requirement increases dramatically in larger sizes.

Dual plate check valves are designed such that the discs are hinged at their sides like a door, eliminating the effect of gravity. Consequently, very little energy is needed to open the valve and maintain this position, resulting in lower energy costs.

### BODY SURFACE WITH UNINTERRUPTED GASKET SURFACE

Proquip dual plate check valves use an internal retention method which does not encroach on the gasket sealing surface. Other retainerless designs have an internal retention method incorporating a special key and retaining screws. These components encroach on the serrated sealing face area restricting the kind of gasket that can be used. Furthermore, the screws can corrode making maintenance difficult.

### INTRINSICALLY FIRE SAFE

With no drilling through the body wall, the Proquip dual plate check valve is intrinsically fire safe.



*Wafer Type - PW  
Dual Plate Check  
Valve shown*

### LAPPED BODY & DISC SEATS

The heart of each valve is the seat/seal interface. Proquip valves are manufactured using the most updated machining methods and equipment to achieve maximum flatness with a fine lapped finish. The end result is valves that easily meet and exceed test requirements of API 598 for metal-seated check valves.

# PROQUIP DUAL PLATE CHECK VALVE DESIGN

## RETAINERLESS BODY DESIGN

The Proquip dual plate check valve's body is essentially a short, heavy wall cylinder with no holes through the body wall. There is no need for retainers and leakage to the outside is impossible.

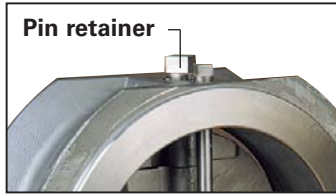

*Conventional dual plate check valve design with pin retainers.*

Conventional dual plate check valves require holes through the body wall to facilitate the installation of the hinge and stop pins. These holes are sealed by threaded pipe plugs called retainers. After being in service for a period of time, these plugs often leak due to temperature cycling, vibration and other causes.

## SHOCK BUMPERS

The Proquip design utilizes heavy duty "shock bumpers" on the back of each disc. These bumpers meet when the valve is in the full open position thus preventing the discs from striking the stop pin. This arrangement reduces the shock force on the hinges, ensuring internal components have an extended cycle life with minimal wear under the most severe service conditions.

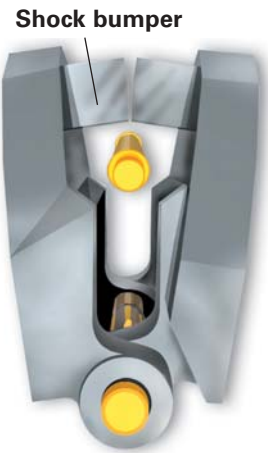

## HIGH TORSION SPRING

For potentially severe applications, a high torsion spring ensures the valve closes as quickly as possible.

## SUPERIOR HINGE DESIGN

In order to eliminate seat wear during the opening cycle, all dual plate check valves incorporate clearance between the hinge pin and holders, or hinge pin and disc bore. This clearance allows the disc assembly to lift off the seat prior to disc rotation preventing the heel of each disc from scraping across the body seat. Conventional designs have an oversize bore in the discs or bearings, allowing constant side to side movement of discs and increased chance of premature failure.

The patented Proquip hinge pin slot allows movement in only one axis preventing premature wear. The discs, therefore, last longer and the useful life of the valve is extended.

**Proquip patented design:** Slot permits movement in direction of flow only (no rattling).

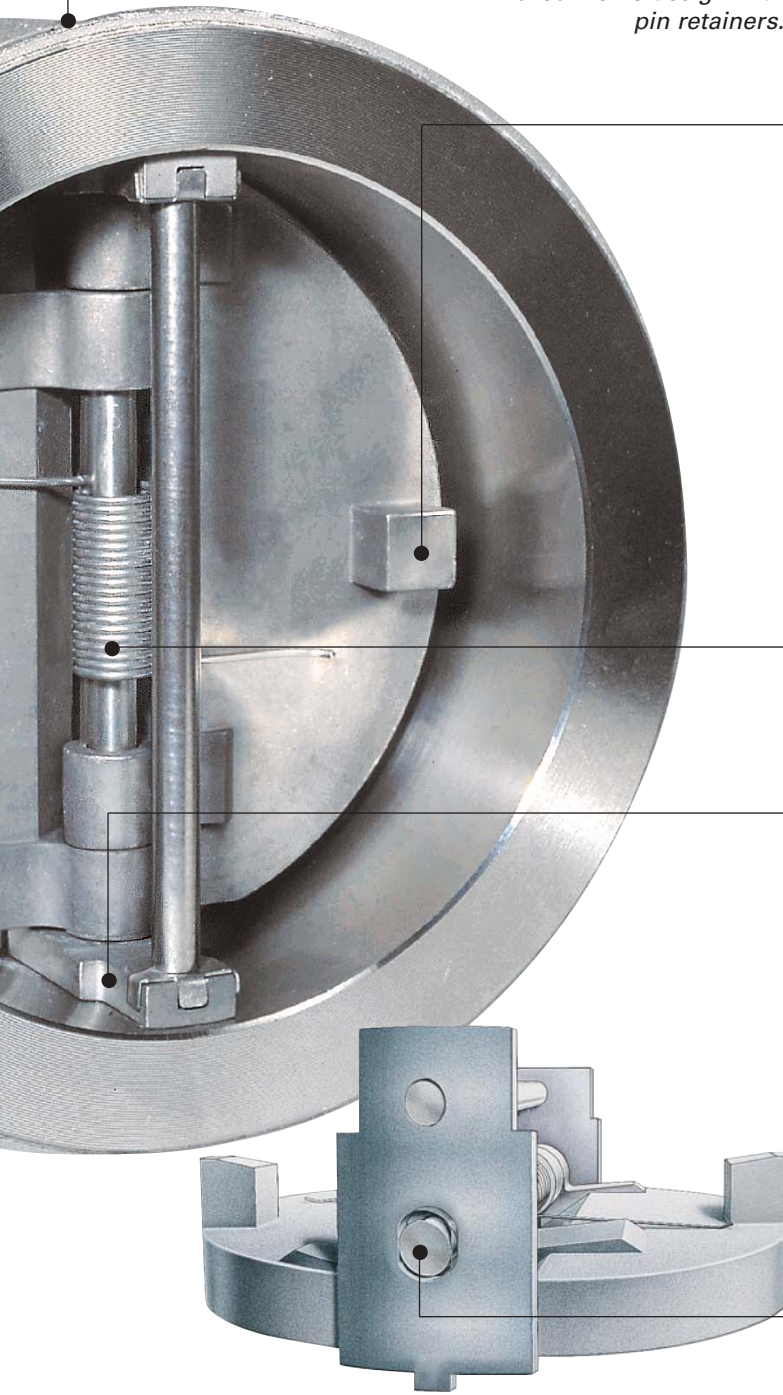

# BODY AND ALL PARTS

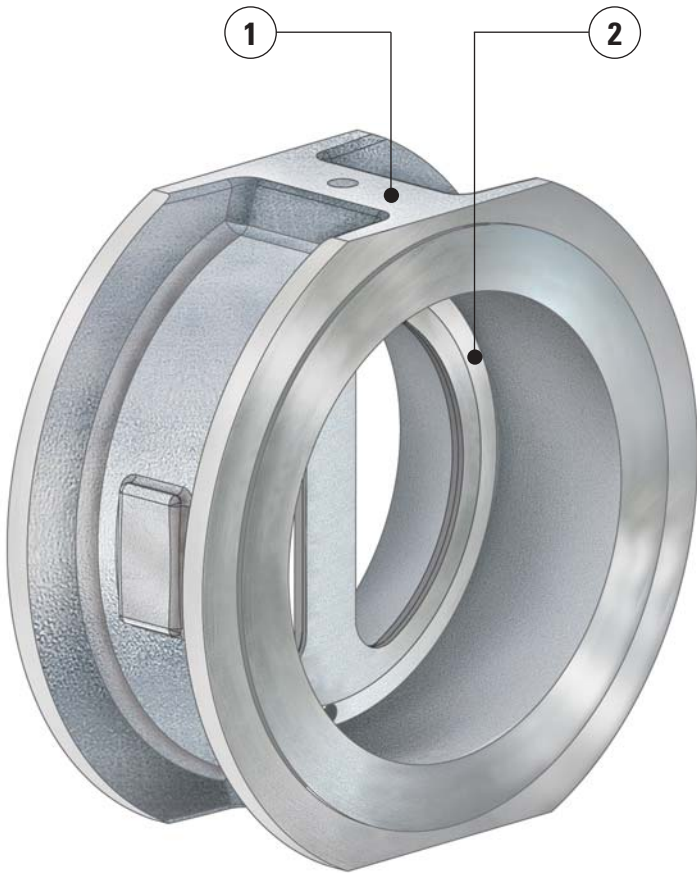

Type PW Wafer dual plate check valve design shown.

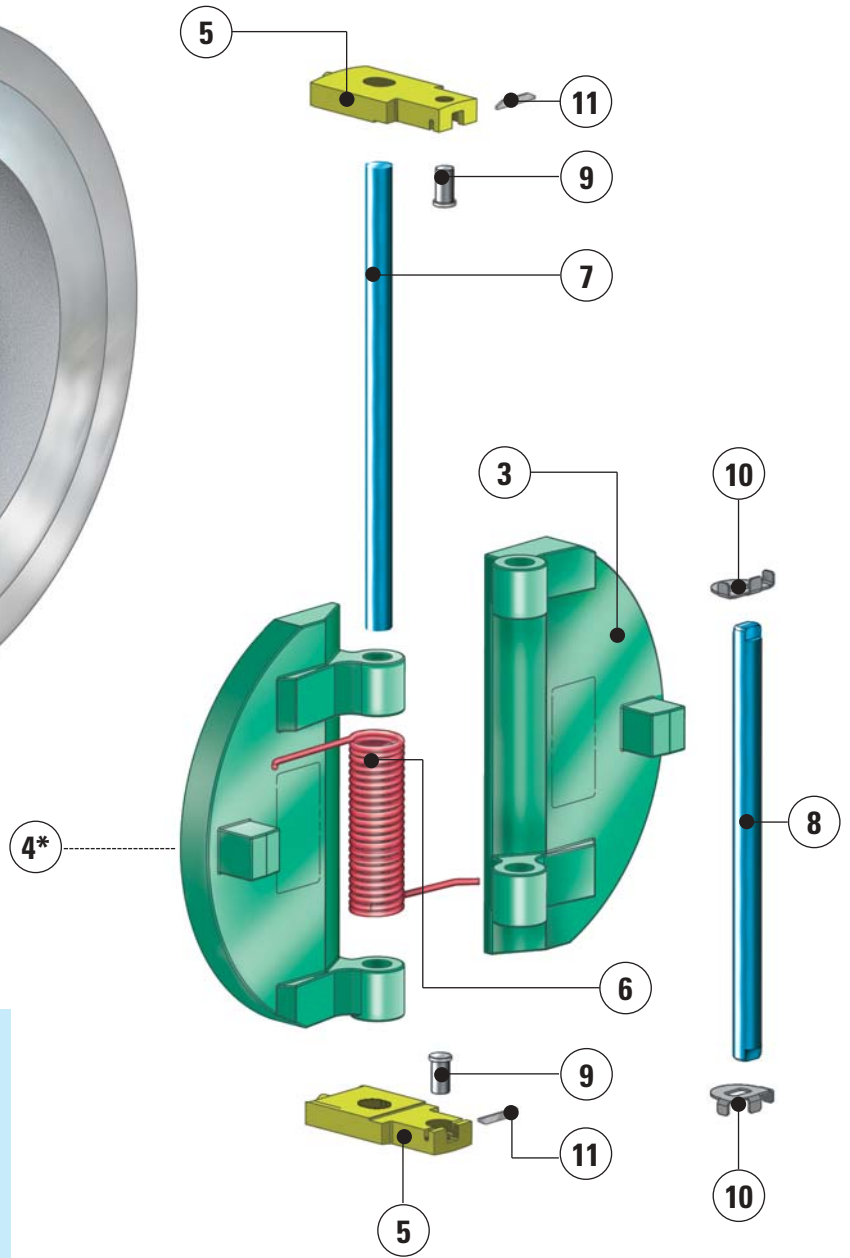

## PART

- |                         |                               |
|-------------------------|-------------------------------|
| 1 Body                  | 7 Hinge pin <sup>(1)</sup>    |
| 2 Body seat             | 8 Stop pin <sup>(1)</sup>     |
| 3 Disc <sup>(1)</sup>   | 9 Retainer pin <sup>(1)</sup> |
| 4 Disc seat             | 10 Lock washer <sup>(1)</sup> |
| 5 Holder <sup>(1)</sup> | 11 Lock pin <sup>(1)</sup>    |
| 6 Spring <sup>(1)</sup> |                               |

(1) Spare part components as required.

\*Disc seat visible on other side of disc

# STANDARD MATERIALS & SPECIFICATIONS

## DESIGN SPECIFICATIONS

ITEM	APPLICABLE SPECIFICATION
Wall thickness and general valve design	API 594
Pressure-temperature rating	ASME B16.34
Face-to-face dimensions	API 594
Flange design	2-24" (50-600 mm) ASME B16.5 26" (650 mm) B16.47 Series A
Testing	API 598
Materials	ASTM

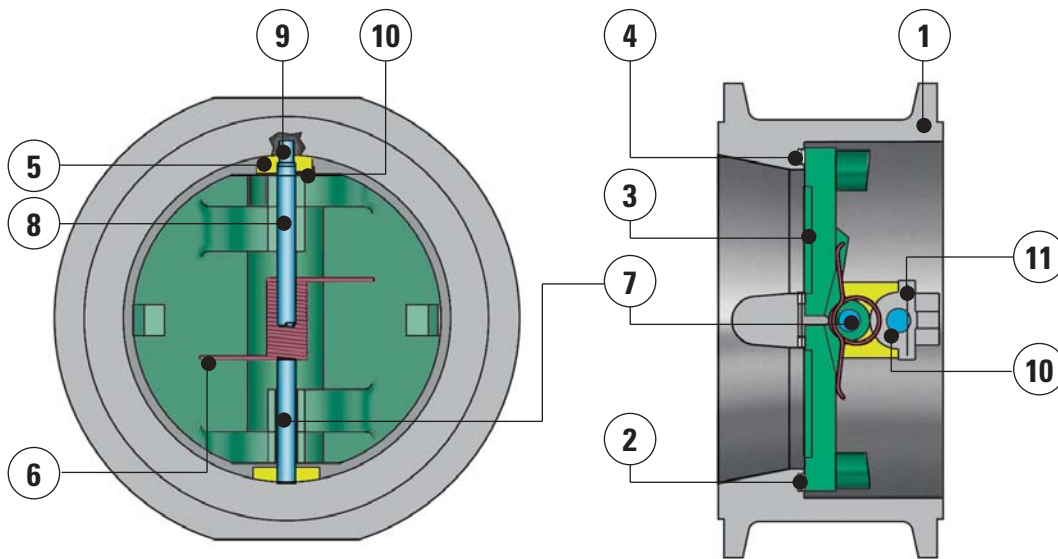

## CARBON STEEL <sup>(1)</sup>

FIGURE NO.	① BODY	③ DISC	② BODY SEAT	④ DISC SEAT	⑥ SPRING	WETTED PARTS <sup>(2)</sup>
____ - _02D10-3DB	A216 Gr. WCB	A351 Gr. CF8M	Same as Body	Same as Disc	Inconel X-750	316 SS
____ - _02D13-3DB	A216 Gr. WCB	A351 Gr. CF8M	Viton A	Same as Disc	Inconel X-750	316 SS
____ - _02D19-3DB	A216 Gr. WCB	A351 Gr. CF8M	Stellite overlay	Same as Disc	Inconel X-750	316 SS
____ - _02E18-3EB	A216 Gr. WCB	A217 Gr. CA15	410 SS overlay	Same as Disc	Inconel X-750	410 SS <sup>(3)</sup>
____ - _02E19-3EB	A216 Gr. WCB	A217 Gr. CA15	Stellite overlay	Same as Disc	Inconel X-750	410 SS <sup>(3)</sup>

## LOW TEMPERATURE CARBON STEEL

FIGURE NO.	① BODY	③ DISC	② BODY SEAT	④ DISC SEAT	⑥ SPRING	WETTED PARTS <sup>(2)</sup>
____ - _31D10-3DB	A352 Gr. LCC	A351 Gr. CF8M	Same as Body	Same as Disc	Inconel X-750	316 SS
____ - _31D11-3DB	A352 Gr. LCC	A351 Gr. CF8M	Buna-N	Same as Disc	Inconel X-750	316 SS
____ - _31D19-3DB	A352 Gr. LCC	A351 Gr. CF8M	Stellite overlay	Same as Disc	Inconel X-750	316 SS

## STAINLESS STEEL

FIGURE NO.	① BODY	③ DISC	② BODY SEAT	④ DISC SEAT	⑥ SPRING	WETTED PARTS <sup>(2)</sup>
____ - _13D10-3DB	A351 Gr. CF8M	A351 Gr. CF8M	Same as Body	Same as Disc	Inconel X-750	316 SS
____ - _13D13-3DB	A351 Gr. CF8M	A351 Gr. CF8M	Viton A	Same as Disc	Inconel X-750	316 SS
____ - _13D19-3DB	A351 Gr. CF8M	A351 Gr. CF8M	Stellite overlay	Same as Disc	Inconel X-750	316 SS

(1) For alternative materials, please consult the HTO table on Page 25.

(2) Wetted parts comprise the following components: Holders, Hinge Pin, Stop Pin and Retainer Pins (part numbers 5, 7, 8, and 9).

(3) The Lock Washer and Lock Pin (part numbers 10 and 11) remain as 316 SS.

# DIMENSIONS & WEIGHTS

## PW WAFER TYPE DUAL PLATE CHECK VALVES

ASME CLASSES 150–2500, 2–60" (50–1500 mm)

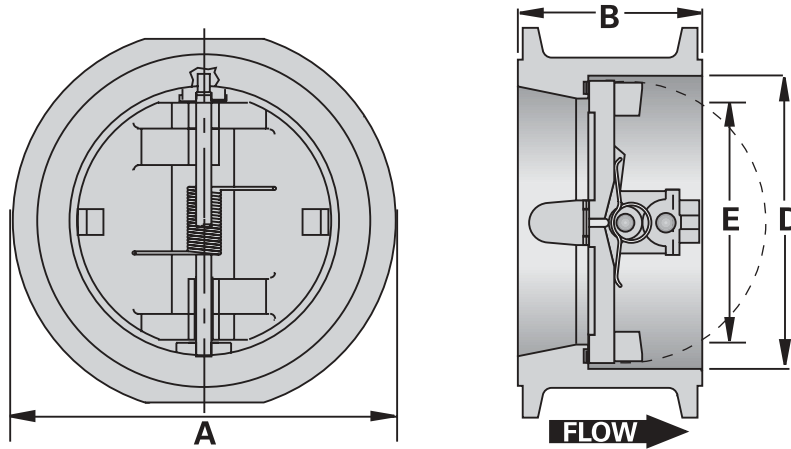

**DIMENSIONS & WEIGHTS / PW – Wafer Type – ASME Class 150**

SIZE		DIMENSIONS								STUD DETAILS				END FACING	EYE BOLT HOLE SIZE <sup>(1)</sup>		APPROXIMATE WEIGHT		
		A		B		D		E		No.	Diameter		RF Stud Length		in	mm	lbs	kg	
NPS	DN	in	mm	in	mm	in	mm	in	mm		in	mm	in	mm	in	mm	in	mm	lbs
2"	50	4.13	105	2.38	60	2.38	60	0.00	0	4	0.63	16	5.75	146	RF	–	–	6	3
2½"	65	4.88	124	2.63	67	2.88	73	1.05	27	4	0.63	16	6.25	159	RF	–	–	11	5
3"	80	5.38	137	2.88	73	2.88	73	1.68	43	4	0.63	16	6.75	171	RF	–	–	11	5
4"	100	6.88	175	2.88	73	4.50	114	3.37	85	8	0.63	16	6.75	171	RF	–	–	18	8
5"	125	7.75	197	3.38	86	5.56	141	4.42	112	8	0.75	19	7.50	191	RF	–	–	28	13
6"	150	8.75	222	3.88	98	6.63	168	5.62	143	8	0.75	19	8.00	203	RF	0.50	13	31	14
8"	200	11.00	279	5.00	127	8.63	219	7.35	187	8	0.75	19	9.50	241	RF	0.50	13	57	26
10"	250	13.38	340	5.75	146	10.75	273	9.45	240	12	0.88	22	10.50	267	RF	0.50	13	98	45
12"	300	16.13	410	7.13	181	12.75	324	11.15	283	12	0.88	22	12.25	311	RF	0.75	19	140	64
14"	350	17.75	451	7.25	184	14.00	356	12.23	311	12	1.00	25	12.75	324	RF	0.75	19	170	77
16"	400	20.25	514	7.50	191	16.00	406	13.99	355	16	1.13	29	13.25	337	RF	1.00	25	230	104
18"	450	21.63	549	8.00	203	18.00	457	15.95	405	16	1.13	29	14.25	362	RF	1.00	25	270	123
20"	500	23.88	606	8.63	219	20.00	508	17.78	452	20	1.25	32	15.25	387	RF	1.00	25	360	163
24"	600	28.25	718	8.75	222	24.00	610	21.29	541	20	1.25	32	16.00	406	RF	1.00	25	480	218
26"	650	30.50	775	14.00	356	26.00	660	21.96	558	24	1.25	32	23.25	591	RF	1.00	25	1000	454
28"	700	32.75	832	15.00	381	28.00	711	22.06	560	28	1.25	32	24.50	622	RF	1.00	25	1200	544
30"	750	34.75	883	12.00	305	30.00	762	27.80	706	28	1.25	32	21.75	552	RF	1.00	25	1000	454
32"	800	37.00	940	14.00	356	32.00	813	29.25	743	28	1.50	38	24.75	629	RF	1.00	25	1400	635
36"	900	41.25	1048	14.50	368	36.00	914	33.40	848	32	1.50	38	26.00	660	RF	1.00	25	1750	794
40"	1000	45.75	1162	17.00	432	40.00	1016	37.56	954	36	1.50	38	28.50	724	RF	1.50	38	2600	1179
42"	1050	48.00	1219	17.00	432	42.00	1067	39.20	996	36	1.50	38	29.00	737	RF	1.50	38	2850	1293
48"	1200	54.50	1384	20.63	524	48.00	1219	43.06	1094	44	1.50	38	31.00	787	RF	1.50	38	4400	1996
54"	1350	61.00	1549	23.25	591	54.00	1372	50.44	1281	44	1.75	44	35.75	908	RF	1.50	38	5500 <sup>(2)</sup>	2495 <sup>(2)</sup>
60"	1500	67.50	1715	26.00	660	60.00	1524	55.68	1414	52	1.75	44	38.75	984	RF	1.50	38	7200 <sup>(2)</sup>	3266 <sup>(2)</sup>

(1) On models where available, the valve body eye bolt hole connection size has been provided as reference for lifting equipment. (2) Estimated weight

# DIMENSIONS & WEIGHTS

## PW WAFER TYPE DUAL PLATE CHECK VALVES

ASME CLASSES 150–2500, 2–60" (50–1500 mm)

### DIMENSIONS & WEIGHTS / PW – Wafer Valves – ASME Class 300

SIZE		DIMENSIONS								STUD DETAILS				END FACING	EYE BOLT HOLE SIZE <sup>(1)</sup>		APPROXIMATE WEIGHT		
		A		B		D		E		No.	Diameter		RF Stud Length		in	mm	lbs	kg	
NPS	DN	in	mm	in	mm	in	mm	in	mm		in	mm	in	mm					in
2"	50	4.38	111	2.38	60	2.38	60	0.00	0	8	0.63	16	6.00	152	RF	–	–	6.5	3
2½"	65	5.13	130	2.63	67	2.88	73	1.19	30	8	0.75	19	6.75	171	RF	–	–	13	6
3"	80	5.88	149	2.88	73	2.91	74	1.90	48	8	0.75	19	7.25	184	RF	–	–	13	6
4"	100	7.13	181	2.88	73	4.50	114	3.37	85	8	0.75	19	7.50	191	RF	–	–	18	8
5"	125	8.50	216	3.38	86	5.56	141	4.42	112	8	0.75	19	8.25	210	RF	–	–	28	13
6"	150	9.88	251	3.88	98	6.63	168	5.47	139	12	0.75	19	9.00	229	RF	0.50	13	40	18
8"	200	12.13	308	5.00	127	8.63	219	7.35	187	12	0.88	22	10.75	273	RF	0.50	13	68	31
10"	250	14.25	362	5.75	146	10.75	273	9.45	240	16	1.00	25	12.25	311	RF	0.50	13	110	50
12"	300	16.63	422	7.13	181	12.75	324	11.15	283	16	1.13	29	14.25	362	RF	0.75	19	170	77
14"	350	19.13	486	8.75	222	14.00	356	12.27	312	20	1.13	29	16.00	406	RF	0.75	19	290	132
16"	400	21.25	540	9.13	232	16.00	406	14.13	359	20	1.25	32	17.00	432	RF	1.00	25	400	181
18"	450	23.50	597	10.38	264	18.00	457	16.44	418	24	1.25	32	18.50	470	RF	1.00	25	520	236
20"	500	25.75	654	11.50	292	20.00	508	17.81	452	24	1.25	32	20.00	508	RF	1.00	25	700	318
24"	600	30.50	775	12.50	318	24.00	610	21.87	555	24	1.50	38	22.00	559	RF	1.00	25	1050	476
26"	650	32.88	835	14.00	356	26.00	660	22.85	580	28	1.63	41	25.00	635	RF	1.00	25	1250	567
28"	700	35.38	899	15.00	381	28.00	711	24.41	620	28	1.63	41	26.50	673	RF	1.00	25	1500	680
30"	750	37.50	953	14.50	368	30.00	762	27.69	703	28	1.75	44	26.75	679	RF	1.00	25	1650	748
32"	800	39.63	1006	16.00	406	32.00	813	28.93	735	28	1.88	48	29.00	737	RF	1.00	25	2000	907
36"	900	44.00	1118	19.00	483	36.00	914	32.41	823	32	2.00	51	32.75	832	RF	1.00	25	2700	1225
40"	1000	43.88	1114	21.50	546	36.00	914	36.29	922	32	1.63	41	35.25	895	RF	1.50	38	3400	1542
42"	1050	45.88	1165	22.38	568	40.00	1016	35.99	914	32	1.63	41	36.50	927	RF	1.50	38	4200	1905
48"	1200	52.13	1324	24.75	629	44.00	1118	43.68	1109	32	1.88	48	40.50	1029	RF	1.50	38	7350	3334
54"	1350	58.75	1492	28.25	718	50.00	1270	48.65	1236	28	2.25	57	46.25	1175	RF	1.50	38	7300 <sup>(2)</sup>	3311 <sup>(2)</sup>
60"	1500	64.75	1645	33.00	838	56.00	1422	48.00	1219	32	2.25	57	51.75	1314	RF	1.50	38	10000 <sup>(2)</sup>	4536 <sup>(2)</sup>

### DIMENSIONS & WEIGHTS / PW – Wafer Valves – ASME Class 600

SIZE		DIMENSIONS								STUD DETAILS						END FACING	EYE BOLT HOLE SIZE <sup>(1)</sup>		APPROXIMATE WEIGHT		
		A		B		D		E		No.	Diameter		RF Stud Length		RTJ Stud Length		in	mm	lbs	kg	
NPS	DN	in	mm	in	mm	in	mm	in	mm		in	mm	in	mm	in	mm					in
2"	50	4.38	111	2.38	60	2.38	60	0.00	0	8	0.63	16	6.50	165	7.00	178	RF/RTJ#23	–	–	6.5	3
3"	80	5.88	149	2.88	73	2.91	74	2.14	54	8	0.75	19	7.75	197	8.25	210	RF/RTJ#31	–	–	13	6
4"	100	7.63	194	3.13	79	4.50	114	3.54	90	8	0.88	22	8.75	222	9.25	235	RF/RTJ#37	–	–	24	11
6"	150	10.50	267	5.38	137	6.63	168	5.22	133	12	1.00	25	12.00	305	12.75	324	RF/RTJ#45	0.50	13	69	31
8"	200	12.63	321	6.50	165	8.63	219	6.98	177	12	1.13	29	14.25	362	14.75	375	RF/RTJ#49	0.50	13	116	53
10"	250	15.75	400	8.38	213	10.75	273	9.08	231	16	1.25	32	17.00	432	17.50	445	RF/RTJ#53	0.50	13	210	95
12"	300	18.00	457	9.00	229	12.75	324	11.32	288	20	1.25	32	17.75	451	18.25	464	RF/RTJ#57	0.75	19	300	136
14"	350	19.38	492	10.75	273	14.00	356	12.46	316	20	1.38	35	20.25	514	20.75	527	RF/RTJ#61	0.75	19	430	195
16"	400	22.25	565	12.00	305	16.00	406	12.89	327	20	1.50	38	22.25	565	22.75	578	RF/RTJ#65	1.00	25	650	295
18"	450	24.13	613	14.25	362	18.00	457	14.52	369	20	1.63	41	25.25	641	25.75	654	RF/RTJ#69	1.00	25	850	386
20"	500	26.88	683	14.50	368	20.00	508	17.06	433	24	1.63	41	26.00	660	26.75	679	RF/RTJ#73	1.00	25	1125	510
24"	600	31.13	791	17.25	438	24.00	610	20.18	513	24	1.63	41	29.75	756	30.75	781	RF/RTJ#77	1.00	25	1750	794
26"	650	34.13	867	18.00	457	26.00	660	21.74	552	28	1.88	48	31.75	806	32.75	832	RF/RTJ#93	1.00	25	1950	885
28"	700	36.00	914	19.00	483	28.00	711	23.89	607	28	2.00	51	33.25	845	34.25	870	RF/RTJ#94	1.00	25	2300	1043
30"	750	38.25	972	19.88	505	30.00	762	27.88	708	28	2.00	51	34.25	870	35.25	895	RF/RTJ#95	1.00	25	2850	1293
32"	800	40.25	1022	21.00	533	32.00	813	27.92	709	28	2.25	57	36.25	921	37.25	946	RF/RTJ#96	1.00	25	3200	1452
36"	900	44.50	1130	25.00	635	36.00	914	31.47	799	28	2.50	64	41.25	1048	42.50	1080	RF/RTJ#98	1.00	25	4700	2132
40"	1000	45.50	1156	26.00	660	36.00	914	33.38	848	32	2.25	57	44.50	1130	–	–	RF	1.50	38	5200	2359
42"	1050	48.00	1219	27.63	702	38.00	965	36.78	934	28	2.50	64	47.25	1200	–	–	RF	1.50	38	6000	2722
48"	1200	54.75	1391	31.00	787	42.00	1067	42.25	1073	32	2.75	70	52.75	1340	–	–	RF	1.50	38	8600	3901
54"	1350	61.25	1556	35.00	889	48.00	1219	48.34	1228	32	3.00	76	59.00	1499	–	–	RF	1.50	38	12100 <sup>(2)</sup>	5489 <sup>(2)</sup>
60"	1500	68.25	1734	39.00	991	54.00	1372	45.00	1143	28	3.50	89	65.75	1670	–	–	RF	2.00	51	17000 <sup>(2)</sup>	7711 <sup>(2)</sup>

(1) On models where available, the valve body eye bolt hole connection size has been provided as reference for lifting equipment. (2) Estimated weight

# DIMENSIONS & WEIGHTS

## PW WAFER TYPE DUAL PLATE CHECK VALVES

ASME CLASSES 150–2500, 2–60" (50–1500mm)

### DIMENSIONS & WEIGHTS / PW – Wafer Type – ASME Class 900

SIZE		DIMENSIONS								STUD DETAILS						END FACING	EYE BOLT HOLE SIZE <sup>(1)</sup>		APPROXIMATE WEIGHT		
		A		B		D		E		No.	Diameter		RF Stud Length		RTJ Stud Length		in	mm	lbs	kg	
NPS	DN	in	mm	in	mm	in	mm	in	mm		in	mm	in	mm	in	mm					in
2"	50	5.63	143	2.75	70	2.38	60	0	0	8	0.88	22	8.50	216	8.75	222	RF/RTJ#24	–	–	11.5	3
3"	80	6.63	168	3.25	83	2.91	74	2.01	51	8	0.88	22	8.50	216	9.00	229	RF/RTJ#31	–	–	21	10
4"	100	8.13	206	4.00	102	4.50	114	3.36	85	8	1.13	29	10.25	260	10.75	273	RF/RTJ#37	0.38	10	43	20
6"	150	11.38	289	6.25	159	6.63	168	4.87	124	12	1.13	29	13.25	337	13.75	349	RF/RTJ#45	0.50	13	125	57
8"	200	14.13	359	8.13	206	8.63	219	5.88	149	12	1.38	35	16.25	413	16.75	425	RF/RTJ#49	0.50	13	275	125
10"	250	17.13	435	9.50	241	10.75	273	9.12	232	16	1.38	35	18.50	470	18.75	476	RF/RTJ#53	0.50	13	400	181
12"	300	19.63	498	11.50	292	12.75	324	9.98	253	20	1.38	35	20.75	527	21.25	540	RF/RTJ#57	0.75	19	450	204
14"	350	20.50	521	14.00	356	14.00	356	9.30	236	20	1.50	38	23.75	603	24.50	622	RF/RTJ#62	0.75	19	700	318
16"	400	22.63	575	15.13	384	16.00	406	12.25	311	20	1.63	41	25.50	648	26.25	667	RF/RTJ#66	1.00	25	950	431
18"	450	25.13	638	17.75	451	18.00	457	14.06	357	20	1.88	48	29.25	743	30.00	762	RF/RTJ#70	1.00	25	1400	635
20"	500	27.50	699	17.75	451	20.00	508	17.06	433	20	2.00	51	30.00	762	31.00	787	RF/RTJ#74	1.00	25	1650	748
24"	600	33.00	838	19.50	495	24.00	610	16.56	421	20	2.50	64	33.75	857	35.00	889	RF/RTJ#78	1.00	25	2325	1055
26"	650	34.75	883	21.00	533	24.00	610	20.51	521	20	2.75	70	39.00	991	40.25	1022	RF/RTJ#100	1.00	25	2700	1225
28"	700	37.25	946	22.50	572	26.00	660	21.53	547	20	3.00	76	41.25	1048	42.50	1080	RF/RTJ#101	1.00	25	3300	1497
30"	750	39.75	1010	25.00	635	28.00	711	27.88	708	20	3.00	76	44.25	1124	45.75	1162	RF/RTJ#102	1.00	25	4100	1860
32"	800	42.25	1073	26.00	660	30.00	762	25.33	643	20	3.25	83	46.50	1181	47.75	1213	RF/RTJ#103	1.00	25	4900	2223
36"	900	47.25	1200	28.25	718	34.00	864	31.47	799	20	3.50	89	50.25	1276	51.75	1314	RF/RTJ#105	1.00	25	6600	2994
40"	1000	49.25	1251	30.00	762	34.00	864	32.61	828	24	3.50	89	54.00	1372	–	–	RF	1.50	38	7800	3538
42"	1050	51.25	1302	31.00	787	36.00	914	34.61	879	24	3.50	89	55.75	1416	–	–	RF	1.50	38	8700	3946
48"	1200	58.50	1486	34.00	864	42.00	1067	41.67	1058	24	4.00	102	61.75	1568	–	–	RF	1.50	38	12500	5670

### DIMENSIONS & WEIGHTS / PW – Wafer Type – ASME Class 1500

SIZE		DIMENSIONS								STUD DETAILS						END FACING	EYE BOLT HOLE SIZE <sup>(1)</sup>		APPROXIMATE WEIGHT		
		A		B		D		E		No.	Diameter		RF Stud Length		RTJ Stud Length		in	mm	lbs	kg	
NPS	DN	in	mm	in	mm	in	mm	in	mm		in	mm	in	mm	in	mm					in
2"	50	5.63	143	2.75	70	2.38	60	0.00	0	8	0.88	22	8.50	216	8.75	222	RF/RTJ#24	–	–	11.5	5
3"	80	6.88	175	3.25	83	2.91	74	2.01	51	8	1.13	29	10.25	260	10.50	267	RF/RTJ#35	–	–	23	10
4"	100	8.25	210	4.00	102	4.50	114	3.18	81	8	1.25	32	11.75	298	12.00	305	RF/RTJ#39	0.38	10	45	20
6"	150	11.13	283	6.25	159	6.63	168	4.87	124	12	1.38	35	16.50	419	17.00	432	RF/RTJ#46	0.50	13	125	57
8"	200	13.88	352	8.13	206	8.63	219	5.88	149	12	1.63	41	19.75	502	20.50	521	RF/RTJ#50	0.50	13	275	125
10"	250	17.13	435	9.75	248	10.75	273	9.12	232	12	1.88	48	23.25	591	23.75	603	RF/RTJ#54	0.50	13	430	195
12"	300	20.50	521	12.00	305	12.75	324	9.98	253	16	2.00	51	27.00	686	28.00	711	RF/RTJ#58	0.75	19	700	318
14"	350	22.75	578	14.00	356	14.00	356	9.30	236	16	2.25	57	30.25	768	31.50	800	RF/RTJ#63	0.75	19	925	420
16"	400	25.25	641	15.13	384	16.00	406	10.89	277	16	2.50	64	32.75	832	34.25	870	RF/RTJ#67	1.00	25	1300	590
18"	450	27.75	705	18.44	468	18.00	457	9.36	238	16	2.75	70	38.00	965	39.50	1003	RF/RTJ#71	1.00	25	1900	862
20"	500	29.75	756	21.00	533	20.00	508	17.06	433	16	3.00	76	42.25	1073	44.00	1118	RF/RTJ#75	1.00	25	2600	1179
24"	600	35.50	902	22.00	559	24.00	610	20.18	513	16	3.50	89	46.25	1175	48.50	1232	RF/RTJ#79	1.00	25	3725	1690

### DIMENSIONS & WEIGHTS / PW – Wafer Type – ASME Class 2500

SIZE		DIMENSIONS								STUD DETAILS						END FACING	EYE BOLT HOLE SIZE <sup>(1)</sup>		APPROXIMATE WEIGHT		
		A		B		D		E		No.	Diameter		RF Stud Length		RTJ Stud Length		in	mm	lbs	kg	
NPS	DN	in	mm	in	mm	in	mm	in	mm		in	mm	in	mm	in	mm					in
2"	50	5.75	146	2.75	70	2.38	60	0.00	0	8	1.00	25	9.75	248	10.00	254	RF/RTJ#26	–	–	13	6
3"	80	7.75	197	3.38	86	2.91	74	2.01	51	8	1.25	32	12.00	305	12.50	318	RF/RTJ#32	0.38	10	34	15
4"	100	9.25	235	4.13	105	4.50	114	3.18	81	8	1.50	38	14.25	362	14.75	375	RF/RTJ#38	0.38	10	56	25
6"	150	12.50	318	6.25	159	6.63	168	5.29	134	8	2.00	51	20.00	508	20.75	527	RF/RTJ#47	0.50	13	150	68
8"	200	15.25	387	8.13	206	8.63	219	5.46	139	12	2.00	51	23.25	591	24.25	616	RF/RTJ#51	0.50	13	310	141
10"	250	18.75	476	10.00	254	10.75	273	8.69	221	12	2.50	64	29.25	743	30.50	775	RF/RTJ#55	0.50	13	500	227
12"	300	21.63	549	12.00	305	12.75	324	9.98	253	12	2.75	70	33.25	845	34.75	883	RF/RTJ#60	0.75	19	875	397

(1) On models where available, the valve body eye bolt hole connection size has been provided as reference for lifting equipment.

# DIMENSIONS & WEIGHTS

## PW WAFER TYPE DUAL PLATE CHECK VALVES

API 6A CLASSES 2000–5000, 2 1/16–20 3/4"

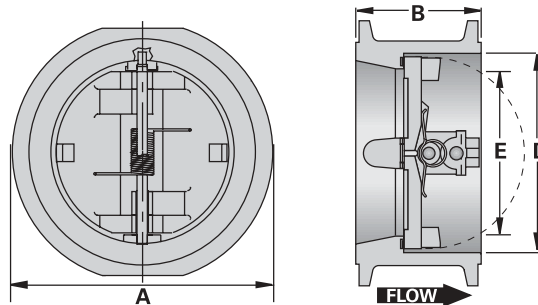

### DIMENSIONS & WEIGHTS / PW – Wafer Type – API 6A Class 2000

SIZE	DIMENSIONS								STUD DETAILS						END FACING	EYE BOLT HOLE SIZE <sup>(1)</sup>		APPROXIMATE WEIGHT		
	A		B		D		E		No.	Diameter		RF Stud Length		RTJ Stud Length		in	mm	lbs	kg	
	in	mm	in	mm	in	mm	in	mm		in	mm	in	mm	in						mm
2 1/16"	6.50	165	2.75	60	2.38	60	0.00	0	8	0.63	16	3.25	83	3.75	95	RF/RTJ#23	–	–	18	8
2 9/16"	7.50	191	3.25	67	2.88	73	0.00	0	8	0.75	19	3.75	95	4.00	102	RF/RTJ#26	–	–	29	13
3 1/8"	8.25	210	3.25	73	2.91	74	2.14	54	8	0.75	19	3.75	95	4.25	108	RF/RTJ#31	–	–	33	15
4 1/16"	10.75	273	4.00	79	4.50	114	3.54	90	8	0.88	22	4.25	108	4.75	121	RF/RTJ#37	–	–	86	39
5 1/8"	13.00	330	4.00	102	5.56	141	4.42	112	8	1.00	25	5.00	127	5.25	133	RF/RTJ#41	–	–	127	58
7 1/16"	14.00	356	6.25	137	6.63	168	5.22	133	12	1.00	25	5.00	127	5.50	140	RF/RTJ#45	0.50	13	172	78
9"	16.50	419	8.12	165	8.63	219	6.98	177	12	1.13	29	5.75	146	6.00	152	RF/RTJ#49	0.50	13	312	142
11"	20.00	508	9.50	213	10.75	273	9.08	231	16	1.25	32	6.25	159	6.75	171	RF/RTJ#53	0.50	13	515	234
13 5/8"	22.00	559	11.50	229	12.75	324	11.32	288	20	1.25	32	6.50	165	6.75	171	RF/RTJ#57	0.75	19	550	250
16 3/4"	27.00	686	12.00	305	16.00	406	12.89	327	20	1.50	38	7.50	191	7.75	197	RF/RTJ#65	1.00	25	1010	458
20 3/4"	32.00	813	14.50	368	20.00	508	17.06	433	24	1.63	41	8.25	210	9.00	229	RF/RTJ#73	1.00	25	1700	771

### DIMENSIONS & WEIGHTS / PW – Wafer Type – API 6A Class 3000

SIZE	DIMENSIONS								STUD DETAILS						END FACING	EYE BOLT HOLE SIZE <sup>(1)</sup>		APPROXIMATE WEIGHT		
	A		B		D		E		No.	Diameter		RF Stud Length		RTJ Stud Length		in	mm	lbs	kg	
	in	mm	in	mm	in	mm	in	mm		in	mm	in	mm	in						mm
2 1/16"	8.50	216	2.75	70	2.38	60	0.00	0	8	0.88	22	4.25	108	4.75	121	RF/RTJ#24	–	–	37	17
2 9/16"	9.63	244	3.25	83	2.88	73	0.00	0	8	1.00	25	4.75	121	5.25	133	RF/RTJ#27	–	–	62	28
3 1/8"	9.50	241	3.25	83	2.91	74	2.01	51	8	0.88	22	4.00	102	4.50	114	RF/RTJ#31	–	–	60	27
4 1/16"	11.50	292	4.00	102	4.50	114	3.36	85	8	1.13	29	5.00	127	5.50	140	RF/RTJ#37	–	–	95	43
5 1/8"	13.75	349	5.25	133	5.56	141	4.00	102	8	1.25	32	5.50	140	6.00	152	RF/RTJ#41	–	–	190	86
7 1/16"	15.00	381	6.25	159	6.63	168	4.87	124	12	1.13	29	5.25	133	5.75	146	RF/RTJ#45	0.50	13	255	116
9"	18.50	470	8.12	206	8.63	219	5.88	149	12	1.38	35	6.25	159	6.75	171	RF/RTJ#49	0.50	13	480	218
11"	21.50	546	9.75	241	10.75	273	9.12	232	16	1.38	35	6.50	165	7.00	178	RF/RTJ#53	0.50	13	730	331
13 5/8"	24.00	610	12.00	292	12.75	324	9.98	253	20	1.38	35	6.75	171	7.25	184	RF/RTJ#57	0.75	19	770	349
16 3/4"	27.75	705	15.13	384	16.00	406	12.25	311	20	1.63	41	7.75	197	8.50	216	RF/RTJ#66	1	25	1210	549
20 3/4"	33.75	857	17.75	451	20.00	508	17.06	433	20	2.00	51	9.25	235	10.00	254	RF/RTJ#74	1	25	3940	1787

### DIMENSIONS & WEIGHTS / PW – Wafer Type – API 6A Class 5000

SIZE	DIMENSIONS								STUD DETAILS						END FACING	EYE BOLT HOLE SIZE <sup>(1)</sup>		APPROXIMATE WEIGHT		
	A		B		D		E		No.	Diameter		RF Stud Length		RTJ Stud Length		in	mm	lbs	kg	
	in	mm	in	mm	in	mm	in	mm		in	mm	in	mm	in						mm
2 1/16"	8.50	216	2.75	70	2.38	60	0.00	0	8	0.88	22	4.25	108	4.75	121	RF/RTJ#24	–	–	35	16
2 9/16"	9.63	244	3.25	83	2.88	73	0.00	0	8	1.00	25	4.75	121	5.25	133	RF/RTJ#27	–	–	63	29
3 1/8"	10.50	267	3.38	83	2.91	74	2.01	51	8	1.13	29	5.25	133	5.75	146	RF/RTJ#35	–	–	71	32
4 1/16"	12.25	311	4.12	102	4.50	114	3.18	81	8	1.25	32	6.00	152	6.25	159	RF/RTJ#39	–	–	150	68
5 1/8"	14.75	375	5.25	133	5.56	141	4.00	102	8	1.50	38	7.25	184	7.75	197	RF/RTJ#44	–	–	225	102
7 1/16"	15.50	394	6.25	159	6.63	168	4.87	124	12	1.38	35	7.25	184	7.75	197	RF/RTJ#46	0.50	13	265	120
9"	19.00	483	8.12	206	8.63	219	5.88	149	12	1.63	41	8.25	210	9.00	229	RF/RTJ#50	0.50	13	625	284
11"	23.00	584	10.00	248	10.75	273	9.12	232	12	1.88	48	9.50	241	10.25	260	RF/RTJ#54	0.50	13	798	362

(1) On models where available, the valve body eye bolt hole connection size has been provided as reference for lifting equipment.

# DIMENSIONS & WEIGHTS

## PL & PM SOLID LUG TYPE DUAL PLATE CHECK VALVES

ASME CLASSES 150–900, 2–60" (50–1500 mm)

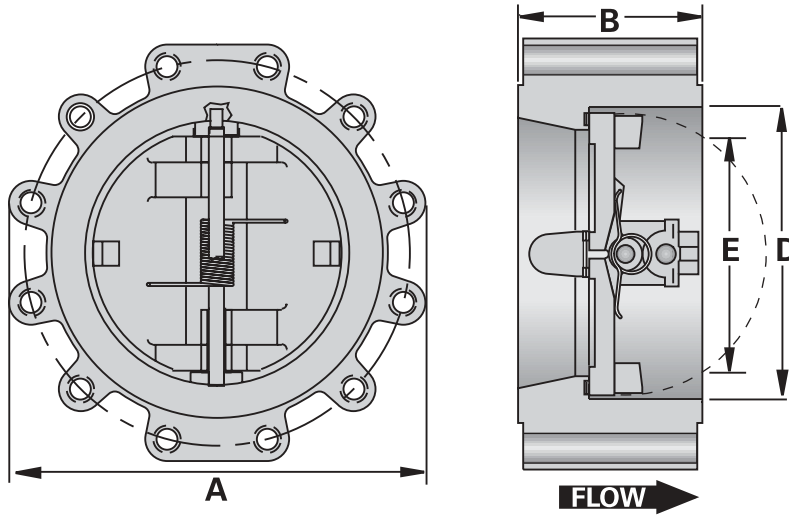

### DIMENSIONS & WEIGHTS / PL & PM – Solid Lug Type – ASME Class 150

SIZE		DIMENSIONS								STUD DETAILS				END FACING	EYE BOLT HOLE SIZE <sup>(1)</sup>		APPROXIMATE WEIGHT		
		A		B		D		E		No.	Diameter		RF Stud Length		in	mm	lbs	kg	
NPS	DN	in	mm	in	mm	in	mm	in	mm		in	mm	in	mm					in
2"	50	6.00	152	2.38	60	2.38	60	0.00	0	4	0.63	16	2.75	70	RF	–	–	9	4
2½"	65	7.00	178	2.63	67	2.88	73	1.05	27	4	0.63	16	2.75	70	RF	–	–	24	11
3"	80	7.50	191	2.88	73	2.88	73	1.68	43	4	0.63	16	3.00	76	RF	–	–	18	8
4"	100	9.00	229	2.88	73	4.50	114	3.37	85	8	0.63	16	3.00	76	RF	–	–	33	15
5"	125	10.00	254	3.38	86	5.56	141	4.42	112	8	0.75	19	3.25	83	RF	–	–	53	24
6"	150	11.00	279	3.88	98	6.63	168	5.62	143	8	0.75	19	3.25	83	RF	0.50	13	53	24
8"	200	13.50	343	5.00	127	8.63	219	7.35	187	8	0.75	19	3.50	89	RF	0.50	13	130	59
10"	250	16.00	406	5.75	146	10.75	273	9.45	240	12	0.88	22	3.75	95	RF	0.50	13	216	98
12"	300	19.00	483	7.13	181	12.75	324	11.15	283	12	0.88	22	3.75	95	RF	0.75	19	270	123
14"	350	21.00	533	7.25	184	14.00	356	12.23	311	12	1.00	25	4.25	108	RF	0.75	19	330	150
16"	400	23.50	597	1.50	38	16.00	406	13.99	355	16	1.00	25	4.25	108	RF	1.00	25	420	191
18"	450	25.00	635	8.00	203	18.00	457	15.95	405	16	1.13	29	4.75	121	RF	1.00	25	500	227
20"	500	27.50	699	8.63	219	20.00	508	17.78	452	20	1.13	29	5.00	127	RF	1.00	25	650	295
24"	600	32.00	813	8.75	222	24.00	610	21.29	541	20	1.25	32	5.50	140	RF	1.00	25	850	386
26"	650	34.25	870	14.00	356	26.00	660	21.96	558	24	1.25	32	6.50	165	RF	1.00	25	1600	726
28"	700	36.50	927	15.00	381	28.00	711	22.06	560	28	1.25	32	6.50	165	RF	1.00	25	1900	862
30"	750	38.75	984	12.00	305	30.00	762	27.80	706	28	1.25	32	6.75	171	RF	1.00	25	1700	771
32"	800	41.75	1060	14.00	356	32.00	813	29.25	743	28	1.50	38	7.50	191	RF	1.00	25	2400	1089
36"	900	46.00	1168	14.50	368	36.00	914	33.40	848	32	1.50	38	8.00	203	RF	1.00	25	2800	1270
40"	1000	50.75	1289	17.00	432	40.00	1016	37.56	954	36	1.50	38	8.00	203	RF	1.50	38	4100	1860
42"	1050	53.00	1346	17.00	432	42.00	1067	39.20	996	36	1.50	38	8.25	210	RF	1.50	38	4400	1996
48"	1200	59.50	1511	20.63	524	48.00	1219	43.06	1094	44	1.50	38	8.75	222	RF	1.50	38	6600	2994
54"	1350	66.25	1683	23.25	591	54.00	1372	50.44	1281	44	1.75	44	9.75	248	RF	1.50	38	8300 <sup>(2)</sup>	3765 <sup>(2)</sup>
60"	1500	73.00	1854	26.00	660	60.00	1524	55.68	1414	52	1.75	44	10.25	260	RF	2.00	51	10700 <sup>(2)</sup>	4853 <sup>(2)</sup>

(1) On models where available, the valve body eye bolt hole connection size has been provided as reference for lifting equipment. (2) Estimated weight

# DIMENSIONS & WEIGHTS

## PL & PM SOLID LUG TYPE DUAL PLATE CHECK VALVES

ASME CLASSES 150–900, 2–60" (50–1500mm)

### DIMENSIONS & WEIGHTS / PL & PM – Solid Lug Type – ASME Class 300

SIZE		DIMENSIONS								STUD DETAILS				END FACING	EYE BOLT HOLE SIZE <sup>(1)</sup>		APPROXIMATE WEIGHT		
		A		B		D		E		No.	Diameter		RF Stud Length		in	mm	lbs	kg	
NPS	DN	in	mm	in	mm	in	mm	in	mm		in	mm	in	mm					in
2"	50	6.50	165	2.38	60	2.38	60	0.00	0	8	0.63	16	2.75	70	RF	–	–	18	8
2½"	65	7.50	191	2.63	67	2.88	73	1.19	30	8	0.75	19	3.25	83	RF	–	–	26	12
3"	80	8.25	210	2.88	73	2.91	74	1.90	48	8	0.75	19	3.50	89	RF	–	–	33	15
4"	100	10.00	254	2.88	73	4.50	114	3.37	85	8	0.75	19	3.50	89	RF	–	–	55	25
5"	125	11.00	279	3.38	86	5.56	141	4.42	112	8	0.75	19	3.75	95	RF	–	–	70	32
6"	150	12.50	318	3.88	98	6.63	168	5.47	139	12	0.75	19	3.75	95	RF	0.50	13	99	45
8"	200	15.00	381	5.00	127	8.63	219	7.35	187	12	0.88	22	4.25	108	RF	0.50	13	143	65
10"	250	17.50	445	5.75	146	10.75	273	9.45	240	16	1.00	25	4.75	121	RF	0.50	13	233	106
12"	300	20.50	521	7.13	181	12.75	324	11.15	283	16	1.13	29	5.25	133	RF	0.75	19	350	159
14"	350	23.00	584	8.75	222	14.00	356	12.27	312	20	1.13	29	5.25	133	RF	0.75	19	550	250
16"	400	25.50	648	9.13	232	16.00	406	14.13	359	20	1.25	32	5.75	146	RF	1.00	25	750	340
18"	450	28.00	711	10.38	264	18.00	457	16.44	418	24	1.25	32	6.00	152	RF	1.00	25	950	431
20"	500	30.50	775	11.50	292	20.00	508	17.81	452	24	1.25	32	6.00	152	RF	1.00	25	1250	567
24"	600	36.00	914	12.50	318	24.00	610	21.87	555	24	1.50	38	7.00	178	RF	1.00	25	1850	839
26"	650	38.25	972	14.00	356	26.00	660	22.85	580	28	1.63	41	7.75	197	RF	1.00	25	2200	998
28"	700	40.75	1035	15.00	381	28.00	711	24.41	620	28	1.63	41	8.25	210	RF	1.00	25	2700	1225
30"	750	43.00	1092	14.50	368	30.00	762	27.69	703	28	1.75	44	8.75	222	RF	1.00	25	2800	1270
32"	800	45.25	1149	16.00	406	32.00	813	28.93	735	28	1.88	48	9.25	235	RF	1.00	25	3400	1542
36"	900	50.00	1270	19.00	483	36.00	914	32.41	823	32	2.00	51	9.75	248	RF	1.00	25	4600	2087
40"	1000	48.75	1238	21.50	546	36.00	914	36.29	922	32	1.63	41	9.25	235	RF	1.50	38	5100	2313
42"	1050	50.75	1289	22.38	568	40.00	1016	35.99	914	32	1.63	41	9.50	241	RF	1.50	38	6100	2767
48"	1200	57.75	1467	24.75	629	44.00	1118	43.68	1109	32	1.88	48	10.50	267	RF	1.50	38	10000	4536
54"	1350	65.25	1657	28.25	718	50.00	1270	48.65	1236	28	2.25	57	12.25	311	RF	1.50	38	11300	5126
60"	1500	71.25	1810	33.00	838	56.00	1422	48.00	1219	32	2.25	57	12.75	324	RF	2.00	51	14800	6713

### DIMENSIONS & WEIGHTS / PL & PM – Solid Lug Type – ASME Class 600

SIZE		DIMENSIONS								STUD DETAILS						END FACING	EYE BOLT HOLE SIZE <sup>(1)</sup>		APPROXIMATE WEIGHT		
		A		B		D		E		No.	Diameter		RF Stud Length		RTJ Stud Length		in	mm	lbs	kg	
NPS	DN	in	mm	in	mm	in	mm	in	mm		in	mm	in	mm	in	mm					in
2"	50	6.50	165	2.38	60	2.38	60	0.00	0	8	0.63	16	3.25	83	3.75	95	RF/RTJ#23	–	–	18	8
3"	80	8.25	210	2.88	73	2.91	74	2.14	54	8	0.75	19	3.75	95	4.25	108	RF/RTJ#31	–	–	33	15
4"	100	10.75	273	3.13	79	4.50	114	3.54	90	8	0.88	22	4.25	108	4.75	121	RF/RTJ#37	–	–	86	39
6"	150	14.00	356	5.38	137	6.63	168	5.22	133	12	1.00	25	5.00	127	5.50	140	RF/RTJ#45	0.50	13	172	78
8"	200	16.50	419	6.50	165	8.63	219	6.98	177	12	1.13	29	5.75	146	6.00	152	RF/RTJ#49	0.50	13	312	142
10"	250	20.00	508	8.38	213	10.75	273	9.08	231	16	1.25	32	6.25	159	6.75	171	RF/RTJ#53	0.50	13	515	234
12"	300	22.00	559	9.00	229	12.75	324	11.32	288	20	1.25	32	6.50	165	6.75	171	RF/RTJ#57	0.75	19	550	250
14"	350	23.75	603	10.75	273	14.00	356	12.46	316	20	1.38	35	6.75	171	7.25	184	RF/RTJ#61	0.75	19	800	363
16"	400	27.00	686	12.00	305	16.00	406	12.89	327	20	1.50	38	7.50	191	7.75	197	RF/RTJ#65	1.00	25	1150	522
18"	450	29.25	743	14.25	362	18.00	457	14.52	369	20	1.63	41	8.00	203	8.50	216	RF/RTJ#69	1.00	25	1550	703
20"	500	32.00	813	14.50	368	20.00	508	17.06	433	24	1.63	41	8.25	210	9.00	229	RF/RTJ#73	1.00	25	1900	862
24"	600	37.00	940	17.50	445	24.00	610	20.18	513	24	1.63	41	8.75	222	9.50	241	RF/RTJ#77	1.00	25	3000	1361
26"	650	40.00	1016	18.00	457	26.00	660	21.74	552	28	1.88	48	9.50	241	10.50	267	RF/RTJ#93	1.00	25	3400	1542
28"	700	42.25	1073	19.00	483	28.00	711	23.89	607	28	2.00	51	10.00	254	11.00	279	RF/RTJ#94	1.00	25	4000	1814
30"	750	44.50	1130	19.88	505	30.00	762	27.88	708	28	2.00	51	10.25	260	11.25	286	RF/RTJ#95	1.00	25	4700	2132
32"	800	47.00	1194	21.00	533	32.00	813	27.92	709	28	2.25	57	11.00	279	12.00	305	RF/RTJ#96	1.00	25	5400	2449
36"	900	51.75	1314	25.00	635	36.00	914	31.47	799	28	2.50	64	11.75	298	13.00	330	RF/RTJ#98	1.00	25	7800	3538
40"	1000	52.00	1321	26.00	660	36.00	914	33.38	848	32	2.25	57	12.50	318	–	–	RF	1.50	38	8100	3674
42"	1050	55.25	1403	27.63	702	38.00	965	36.78	934	28	2.50	64	13.50	343	–	–	RF	1.50	38	9600	4355
48"	1200	62.75	1594	31.00	787	42.00	1067	42.25	1073	32	2.75	70	15.00	381	–	–	RF	1.50	38	13700	6214
54"	1350	70.00	1778	35.00	889	48.00	1219	48.34	1228	32	3.00	76	16.50	419	–	–	RF	2.00	51	19200 <sup>(2)</sup>	8709 <sup>(2)</sup>
60"	1500	78.50	1994	39.00	991	54.00	1372	45.00	1143	28	3.50	89	18.75	476	–	–	RF	2.50	64	29200 <sup>(2)</sup>	13245 <sup>(2)</sup>

(1) On models where available, the valve body eye bolt hole connection size has been provided as reference for lifting equipment. (2) Estimated weight

# DIMENSIONS & WEIGHTS

## PL & PM SOLID LUG TYPE DUAL PLATE CHECK VALVES

ASME CLASSES 150–900, 2–60" (50–1500 mm)

### DIMENSIONS & WEIGHTS / PL & PM – Solid Lug Type – ASME Class 900

SIZE		DIMENSIONS								STUD DETAILS						END FACING	EYE BOLT HOLE SIZE <sup>(1)</sup>		APPROXIMATE WEIGHT		
		A		B		D		E		No.	Diameter		RF Stud Length		RTJ Stud Length		in	mm	lbs	kg	
		NPS	DN	in	mm	in	mm	in	mm		in	mm	in	mm	in						mm
2"	50	8.50	216	2.75	70	2.38	60	0.00	0	8	0.88	22	4.25	108	4.75	121	RF/RTJ#24	–	–	37	17
3"	80	9.50	241	3.25	83	2.91	74	2.01	51	8	0.88	22	4.00	102	4.50	114	RF/RTJ#31	–	–	60	27
4"	100	11.50	292	4.00	102	4.50	114	3.36	85	8	1.13	29	5.00	127	5.50	140	RF/RTJ#37	–	–	95	43
6"	150	15.00	381	6.25	159	6.63	168	4.87	124	12	1.13	29	5.25	133	5.75	146	RF/RTJ#45	0.50	13	255	116
8"	200	18.50	470	8.13	206	8.63	219	5.88	149	12	1.38	35	6.25	159	6.75	171	RF/RTJ#49	0.50	13	480	218
10"	250	21.50	546	9.50	241	10.75	273	9.12	232	16	1.38	35	6.50	165	7.00	178	RF/RTJ#53	0.50	13	730	331
12"	300	24.00	610	11.50	292	12.75	324	9.98	253	20	1.38	35	6.75	171	7.25	184	RF/RTJ#57	0.75	19	850	386
14"	350	25.25	641	14.00	356	14.00	356	9.30	236	20	1.50	38	7.25	184	7.75	197	RF/RTJ#62	0.75	19	1250	567
16"	400	27.75	705	15.13	384	16.00	406	12.25	311	20	1.63	41	7.75	197	8.50	216	RF/RTJ#66	1.00	25	1650	748
18"	450	31.00	787	17.75	451	18.00	457	14.06	357	20	1.88	48	8.50	216	9.50	241	RF/RTJ#70	1.00	25	2500	1134
20"	500	33.75	857	17.75	451	20.00	508	17.06	433	20	2.00	51	9.25	235	10.00	254	RF/RTJ#74	1.00	25	2900	1315
24"	600	41.00	1041	19.50	495	24.00	610	16.56	421	20	2.50	64	11.00	279	12.00	305	RF/RTJ#78	1.00	25	4400	1996
26"	650	42.75	1086	21.00	533	24.00	610	20.51	521	20	2.75	70	13.00	330	14.50	368	RF/RTJ#100	1.00	25	5000	2268
28"	700	46.00	1168	22.63	575	26.00	660	21.53	547	20	3.00	76	13.75	349	15.25	387	RF/RTJ#101	1.00	25	6200	2812
30"	750	48.50	1232	26.00	660	28.00	711	27.88	708	20	3.00	76	14.00	356	15.50	394	RF/RTJ#102	1.00	25	7500	3402
32"	800	51.75	1314	26.00	660	30.00	762	25.33	643	20	3.25	83	15.00	381	16.50	419	RF/RTJ#103	1.00	25	9000	4082
36"	900	57.50	1461	28.25	718	34.00	864	31.47	799	20	3.50	89	16.25	413	17.75	451	RF/RTJ#105	1.00	25	11900	5398
40"	1000	59.50	1511	30.00	762	34.00	864	32.61	828	24	3.50	89	17.25	438	17.25	438	RF	1.50	38	13700	6214
42"	1050	61.50	1562	31.00	787	36.00	914	34.61	879	24	3.50	89	17.50	445	17.50	445	RF	1.50	38	15000	6804
48"	1200	70.25	1784	34.00	864	42.00	1067	41.67	1058	24	4.00	102	20.00	508	20.00	508	RF	1.50	38	21500	9752

### DIMENSIONS & WEIGHTS / PL & PM – Solid Lug Type – ASME Class 1500

SIZE		DIMENSIONS								STUD DETAILS						END FACING	EYE BOLT HOLE SIZE <sup>(1)</sup>		APPROXIMATE WEIGHT		
		A		B		D		E		No.	Diameter		RF Stud Length		RTJ Stud Length		in	mm	lbs	kg	
		NPS	DN	in	mm	in	mm	in	mm		in	mm	in	mm	in						mm
2"	50	8.50	216	2.75	70	2.38	60	0.00	0	8	0.88	22	4.25	108	4.75	121	RF/RTJ#24	–	–	35	16
3"	80	10.50	267	3.25	83	2.91	74	2.01	51	8	1.13	29	5.25	133	5.75	146	RF/RTJ#35	0.38	10	71	32
4"	100	12.25	311	4.00	102	4.50	114	3.18	81	8	1.25	32	6.00	152	6.25	159	RF/RTJ#39	0.50	13	150	68
6"	150	15.50	394	6.25	159	6.63	168	4.87	124	12	1.38	35	7.25	184	7.75	197	RF/RTJ#46	0.50	13	265	120
8"	200	19.00	483	8.13	206	8.63	219	5.88	149	12	1.63	41	8.25	210	9.00	229	RF/RTJ#50	0.75	19	625	284
10"	250	23.00	584	9.75	248	10.75	273	9.12	232	12	1.88	48	9.50	241	10.25	260	RF/RTJ#54	0.75	19	798	362
12"	300	26.50	673	12.00	305	12.75	324	9.98	253	16	2.00	51	10.50	267	11.50	292	RF/RTJ#58	0.75	19	1400	635
14"	350	29.50	749	14.00	356	14.00	356	9.30	236	16	2.25	57	11.50	292	12.75	324	RF/RTJ#63	1.00	25	2400	1089
16"	400	32.50	826	15.13	384	16.00	406	10.89	277	16	2.50	64	12.75	324	14.00	356	RF/RTJ#67	1.00	25	2500	1134
18"	450	36.00	914	18.44	468	18.00	457	9.36	238	16	2.75	70	14.00	356	15.25	387	RF/RTJ#71	1.50	38	3900	1769
20"	500	38.75	984	21.00	533	20.00	508	17.06	433	16	3.00	76	15.25	387	16.75	425	RF/RTJ#75	1.50	38	5800	2631
24"	600	46.00	1168	22.00	559	24.00	610	20.18	513	16	3.50	89	17.50	445	19.25	489	RF/RTJ#79	1.50	38	7200	3266

### DIMENSIONS & WEIGHTS / PL & PM – Solid Lug Type – ASME Class 2500

SIZE		DIMENSIONS								STUD DETAILS						END FACING	EYE BOLT HOLE SIZE <sup>(1)</sup>		APPROXIMATE WEIGHT		
		A		B		D		E		No.	Diameter		RF Stud Length		RTJ Stud Length		in	mm	lbs	kg	
		NPS	DN	in	mm	in	mm	in	mm		in	mm	in	mm	in						mm
2"	50	9.25	235	2.75	70	2.38	60	0.00	0	8	1.00	25	5.25	133	5.50	140	RF/RTJ#26	–	–	45	20
3"	80	12.00	305	3.38	86	2.91	74	2.01	51	8	1.25	32	6.50	165	7.00	178	RF/RTJ#32	0.38	10	85	39
4"	100	14.00	356	4.13	105	4.50	114	3.18	81	8	1.50	38	7.50	191	8.00	203	RF/RTJ#38	0.50	13	200	91
6"	150	19.00	483	6.25	159	6.63	168	5.29	134	8	2.00	51	10.00	254	10.75	273	RF/RTJ#47	0.50	13	405	184
8"	200	21.75	552	8.13	206	8.63	219	5.46	139	12	2.00	51	10.75	273	11.50	292	RF/RTJ#51	0.75	19	750	340
10"	250	26.50	673	10.00	254	10.75	273	8.69	221	12	2.50	64	13.50	343	14.75	375	RF/RTJ#55	0.75	19	1080	490
12"	300	30.00	762	12.00	305	12.75	324	9.98	253	12	2.75	70	14.75	375	16.25	413	RF/RTJ#60	1.00	25	1600	726

(1) On models where available, the valve body eye bolt hole connection size has been provided as reference for lifting equipment.

# DIMENSIONS & WEIGHTS

## PF & PG DOUBLE FLANGED TYPE DUAL PLATE CHECK VALVES ASME CLASSES 150-900, 12-60" (300-1500mm)

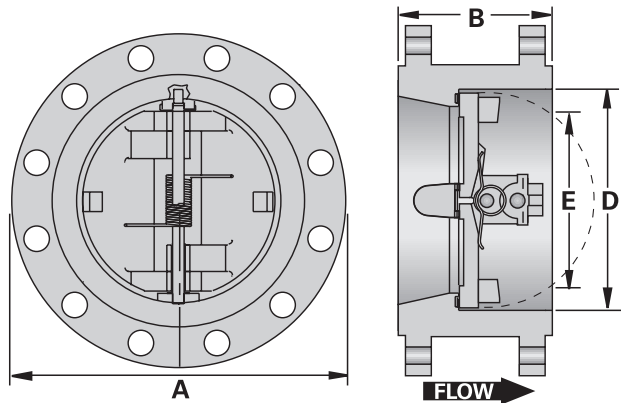

**DIMENSIONS & WEIGHTS / PF & PG – Double Flanged Type – ASME Class 150**

SIZE		DIMENSIONS								STUD DETAILS				END FACING	APPROXIMATE WEIGHT		
		A		B		D		E		No. <sup>(1)</sup>	Diameter		RF Stud Length				
NPS	DN	in	mm	in	mm	in	mm	in	mm		in	mm	in	mm	in	mm	lbs
12"	300	19.00	483	7.13	181	12.75	324	11.15	283	12	0.88	22	4.75	121	RF	279	127
14"	350	21.00	533	7.25	184	14.00	356	12.23	311	12	1.00	25	5.25	133	RF	319	145
16"	400	23.50	597	7.50	191	16.00	406	13.99	355	16	1.00	25	5.50	140	RF	387	176
18"	450	25.00	635	8.00	203	18.00	457	15.95	405	16	1.13	29	6.00	152	RF	460	209
20"	500	27.50	699	8.63	219	20.00	508	17.78	452	20	1.13	29	6.25	159	RF	600	272
24"	600	32.00	813	8.75	222	24.00	610	21.29	541	20	1.25	32	7.00	178	RF	862	391
26"	650	34.25	870	14.00	356	26.00	660	21.96	558	24	1.25	32	8.75	222	RF	1500	680
28"	700	36.50	927	15.00	381	28.00	711	22.06	560	28	1.25	32	9.00	229	RF	1700	771
30"	750	38.75	984	12.00	305	30.00	762	27.80	706	28	1.25	32	9.25	235	RF	1750	794
32"	800	41.75	1060	14.00	356	32.00	813	29.25	743	28	1.50	38	10.50	267	RF	2300	1043
36"	900	46.00	1168	14.50	368	36.00	914	33.40	848	32	1.50	38	11.25	286	RF	2525	1145
40"	1000	50.75	1289	17.00	432	40.00	1016	37.56	954	36	1.50	38	11.25	286	RF	3900	1769
42"	1050	53.00	1346	17.00	432	42.00	1067	39.20	996	36	1.50	38	11.75	298	RF	4220	1914
48"	1200	59.50	1511	20.63	524	48.00	1219	43.06	1094	44	1.50	38	12.50	318	RF	5900	2676
54"	1350	66.25	1683	23.25	591	54.00	1372	50.44	1281	44	1.75	44	14.00	356	RF	7700 <sup>(2)</sup>	3493 <sup>(2)</sup>
60"	1500	73.00	1854	26.00	660	60.00	1524	55.68	1414	52	1.75	44	15.00	381	RF	10000 <sup>(2)</sup>	4536 <sup>(2)</sup>

**DIMENSIONS & WEIGHTS / PF & PG – Double Flanged Type – ASME Class 300**

SIZE		DIMENSIONS								STUD DETAILS				END FACING	APPROXIMATE WEIGHT		
		A		B		D		E		No. <sup>(1)</sup>	Diameter		RF Stud Length				
NPS	DN	in	mm	in	mm	in	mm	in	mm		in	mm	in	mm	in	mm	lbs
12"	300	20.50	521	7.13	181	12.75	324	11.15	283	16	1.13	29	6.75	171	RF	336	152
14"	350	23.00	584	8.75	222	14.00	356	12.27	312	20	1.13	29	7.00	178	RF	431	196
16"	400	25.50	648	9.13	232	16.00	406	14.13	359	20	1.25	32	7.50	191	RF	675	306
18"	450	28.00	711	10.38	264	18.00	457	16.44	418	24	1.25	32	7.75	197	RF	850	386
20"	500	30.50	775	11.50	292	20.00	508	17.81	452	24	1.25	32	8.25	210	RF	1078	489
24"	600	36.00	914	12.50	318	24.00	610	21.87	555	24	1.50	38	9.25	235	RF	1965	891
26"	650	38.25	972	14.00	356	26.00	660	22.85	580	28	1.63	41	10.50	267	RF	2200	998
28"	700	40.75	1035	15.00	381	28.00	711	24.41	620	28	1.63	41	11.00	279	RF	2600	1179
30"	750	43.00	1092	14.50	368	30.00	762	27.69	703	28	1.75	44	11.75	298	RF	3525	1599
32"	800	45.25	1149	16.00	406	32.00	813	28.93	735	28	1.88	48	12.75	324	RF	3300	1497
36"	900	50.00	1270	19.00	483	36.00	914	32.41	823	32	2.00	51	13.25	337	RF	4700	2132
40"	1000	48.75	1238	21.50	546	36.00	914	36.29	922	32	1.63	41	13.25	337	RF	4900	2223
42"	1050	50.75	1289	22.38	568	40.00	1016	35.99	914	32	1.63	41	13.75	349	RF	5000	2268
48"	1200	57.75	1467	24.75	629	44.00	1118	43.68	1109	32	1.88	48	15.25	387	RF	7400	3357
54"	1350	65.25	1657	28.25	718	50.00	1270	48.65	1236	28	2.25	57	17.50	445	RF	10600 <sup>(2)</sup>	4808 <sup>(2)</sup>
60"	1500	71.25	1810	33.00	838	56.00	1422	48.00	1219	32	2.25	57	18.75	476	RF	13000 <sup>(2)</sup>	5897 <sup>(2)</sup>

(1) The number of studs is per flange. Multiply the number of studs by 2 for valve installation requirements (2) Estimated weight

# DIMENSIONS & WEIGHTS

## PF & PG DOUBLE FLANGED TYPE DUAL PLATE CHECK VALVES

ASME CLASSES 150–900, 12–60" (300–1500mm)

### DIMENSIONS & WEIGHTS / PF & PG – Double Flanged Type – ASME Class 600

SIZE		DIMENSIONS								No. <sup>(1)</sup>	STUD DETAILS						END FACING	APPROXIMATE WEIGHT	
		A		B		D		E			Diameter		RF Stud Length		RTJ Stud Length			lbs	kg
NPS	DN	in	mm	in	mm	in	mm	in	mm	in	mm	in	mm	in	mm	in	mm		
12"	300	22.00	559	9.00	229	12.75	324	11.32	288	20	1.25	32	8.50	216	9.00	229	RF/RTJ#57	550	249
14"	350	23.75	603	10.75	273	14.00	356	12.46	316	20	1.38	35	9.00	229	9.50	241	RF/RTJ#61	846	384
16"	400	27.00	686	12.00	305	16.00	406	12.89	327	20	1.50	38	9.75	248	10.25	260	RF/RTJ#65	1010	458
18"	450	29.25	743	14.25	362	18.00	457	14.52	369	20	1.63	41	10.50	267	11.00	279	RF/RTJ#69	1320	599
20"	500	32.00	813	14.50	368	20.00	508	17.06	433	24	1.63	41	11.25	286	11.75	298	RF/RTJ#73	1700	771
24"	600	37.00	940	17.50	445	24.00	610	20.18	513	24	1.63	41	12.25	311	13.00	330	RF/RTJ#77	2580	1170
26"	650	40.00	1016	18.00	457	26.00	660	21.74	552	28	1.88	48	13.25	337	14.25	362	RF/RTJ#93	3100	1406
28"	700	42.25	1073	19.00	483	28.00	711	23.89	607	28	2.00	51	14.00	356	15.00	381	RF/RTJ#94	3800	1724
30"	750	44.50	1130	19.88	505	30.00	762	27.88	708	28	2.00	51	14.00	356	15.00	381	RF/RTJ#95	5390	2445
32"	800	47.00	1194	21.00	533	32.00	813	27.92	709	28	2.25	57	14.75	375	16.00	406	RF/RTJ#96	5000	2268
36"	900	51.75	1314	25.00	635	36.00	914	31.47	799	28	2.50	64	16.00	406	17.00	432	RF/RTJ#98	6700	3039
42"	1050	55.25	1403	27.63	702	38.00	965	36.78	934	28	2.50	64	19.50	495	–	–	RF	9400	4264
48"	1200	62.75	1594	31.00	787	42.00	1067	42.25	1073	32	2.75	70	21.75	552	–	–	RF	13600	6169
54"	1350	70.00	1778	35.00	889	48.00	1219	48.34	1228	32	3.00	76	23.75	603	–	–	RF	18500 <sup>(2)</sup>	8392 <sup>(2)</sup>
60"	1500	78.50	1994	39.00	991	54.00	1372	45.00	1143	28	3.50	89	26.75	679	–	–	RF	23400 <sup>(2)</sup>	10614 <sup>(2)</sup>

### DIMENSIONS & WEIGHTS / PF & PG – Double Flanged Type – ASME Class 900

SIZE		DIMENSIONS								No. <sup>(1)</sup>	STUD DETAILS						END FACING	APPROXIMATE WEIGHT	
		A		B		D		E			Diameter		RF Stud Length		RTJ Stud Length			lbs	kg
NPS	DN	in	mm	in	mm	in	mm	in	mm	in	mm	in	mm	in	mm	in	mm		
12"	300	24.00	610	11.50	292	12.75	324	9.98	253	20	1.38	35	8.75	222	9.25	235	RF/RTJ#57	770	349
14"	350	25.25	641	14.00	356	14.00	356	9.30	236	20	1.50	38	9.25	235	10.00	254	RF/RTJ#62	1240	563
16"	400	27.75	705	15.13	384	16.00	406	12.25	311	20	1.63	41	10.00	254	10.75	273	RF/RTJ#66	1210	549
18"	450	31.00	787	17.75	451	18.00	457	14.06	357	20	1.88	48	11.00	279	11.75	298	RF/RTJ#70	1845	837
20"	500	33.75	857	17.75	451	20.00	508	17.06	433	20	2.00	51	12.00	305	12.75	324	RF/RTJ#74	3940	1787
24"	600	41.00	1041	19.50	495	24.00	610	16.56	421	20	2.50	64	14.00	356	15.00	381	RF/RTJ#78	4175	1894
26"	650	42.75	1086	21.00	533	24.00	610	20.51	521	20	2.75	70	17.50	445	19.00	483	RF/RTJ#100	5000	2268
28"	700	46.00	1168	22.63	575	26.00	660	21.53	547	20	3.00	76	18.50	470	19.75	502	RF/RTJ#101	6000	2722
30"	750	48.50	1232	26.00	660	28.00	711	27.88	708	20	3.00	76	19.00	483	20.50	521	RF/RTJ#102	7000	3175
32"	800	51.75	1314	26.00	660	30.00	762	25.33	643	20	3.25	83	20.25	514	21.75	552	RF/RTJ#103	8500	3856
36"	900	57.50	1461	28.25	718	34.00	864	31.47	799	20	3.50	89	21.75	552	23.50	597	RF/RTJ#105	11300	5126
40"	1000	59.50	1511	30.00	762	34.00	864	32.61	828	24	3.50	89	23.75	603	–	–	RF	13700	6214
42"	1050	61.50	1562	31.00	787	36.00	914	34.61	879	24	3.50	89	24.50	622	–	–	RF	15000	6804
48"	1200	70.25	1784	34.00	864	42.00	1067	41.67	1058	24	4.00	102	27.75	705	–	–	RF	21100	9571

(1) The number of studs is per flange. Multiply the number of studs by 2 for valve installation requirements (2) Estimated weight

# DIMENSIONS & WEIGHTS

## PH HUB END TYPE DUAL PLATE CHECK VALVES

ASME CLASSES 600–2500, 2–12" (50–300 mm)

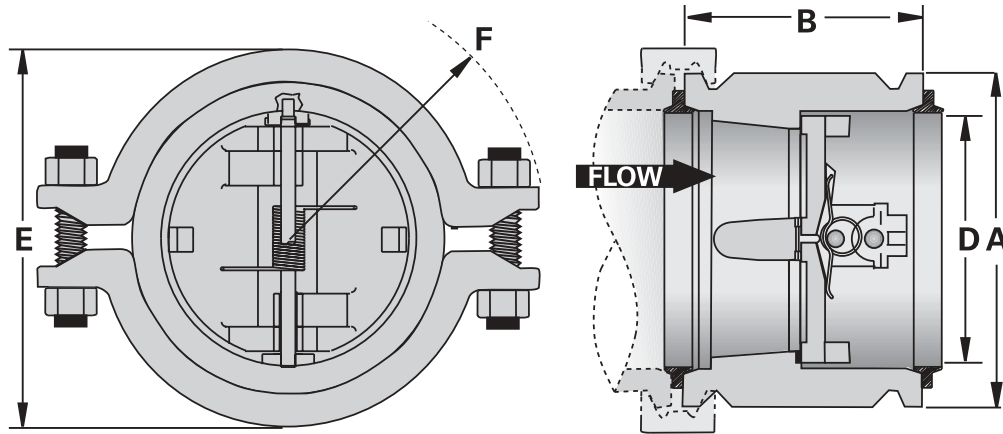

### DIMENSIONS & WEIGHTS / PH – Hub End Type

SIZE		Seal Ring Number	A		B <sup>(1)</sup>		D Seal I.D.	E Clamp O.D.		F Clamp Clearance		APPROXIMATE WEIGHT	
NPS	DN		in	mm	in	mm	in	in	mm	in	mm	lbs	kg
2"	50	20	3.63	92	4.50	114	2.06	5.06	129	4.50	114	11	5
		14	3.63	92	4.50	114	1.16	5.06	129	4.50	114	11	5
3"	80	27	5.00	127	4.50	114	3.06	6.88	175	5.25	133	20	9
		25	5.00	127	4.50	114	2.67	6.88	175	5.25	133	20	9
		20	5.00	127	4.50	114	2.06	6.88	175	5.25	133	20	9
4"	100	40	6.00	152	5.00	127	4.06	8.13	206	6.00	152	24	11
		34	6.00	152	5.00	127	3.69	8.13	206	6.00	152	24	11
		31	6.00	152	5.00	127	3.25	8.13	206	6.00	152	24	11
		25	6.00	152	5.00	127	2.67	8.13	206	6.00	152	33	15
6"	150	62	9.25	235	6.25	159	6.07	12.00	305	8.75	222	77	35
		52	9.25	235	6.25	159	5.31	12.00	305	8.75	222	77	35
		46	9.25	235	6.25	159	4.75	12.00	305	8.75	222	77	35
		40	9.25	235	6.25	159	4.06	12.00	305	8.75	222	88	40
8"	200	82	11.50	292	8.13	206	8.25	14.50	368	9.88	251	158	72
		76	11.50	292	8.13	206	7.75	14.50	368	9.88	251	158	72
		72	11.50	292	8.13	206	7.25	14.50	368	9.88	251	158	72
		62	11.50	292	8.13	206	6.07	14.50	368	9.88	251	183	83
		52	11.50	292	8.13	206	5.31	14.50	368	9.88	251	183	83
10"	250	H97	13.63	346	9.75	248	9.88	17.63	448	12.75	324	242	110
		H94	13.63	346	9.75	248	9.50	17.63	448	12.75	324	242	110
		H84	13.63	346	9.75	248	8.50	17.63	448	12.75	324	308	140
		H82X	13.63	346	9.75	248	8.25	18.25	464	13.50	343	308	140
		H72	13.63	346	9.75	248	7.25	18.25	464	12.75	324	308	140
		H62	13.63	346	9.75	248	6.07	18.25	464	12.75	324	345	157
		H62X	13.63	346	9.75	248	6.07	18.25	464	13.50	343	345	157
12"	300	M120	16.00	406	12.50	318	12.00	20.25	514	14.50	368	389	177
		M112	16.00	406	12.50	318	11.25	20.25	514	14.50	368	389	177
		M102	16.00	406	12.50	318	10.25	20.25	514	14.50	368	502	228
		M82	16.00	406	12.50	318	8.25	20.25	514	14.50	368	590	268
		M82X	16.00	406	12.50	318	8.25	20.50	521	15.75	400	590	268

(1) Body length ("B" dimension) can be increased to suit any requirements

**NOTES:**

- Specify brand of clamp-joint system when ordering.
- Dimensions may change. General Assembly drawings are available upon request
- No clamps, seal rings or companion hubs are included.
- Ask for dimensions for other sizes, ratings and seal ring numbers

# SPECIAL SERVICES

## CRYOGENIC SERVICE

Velan is a leader in cryogenic valve technology for reliability and low fugitive emissions and we offer a wide range of engineered valve solutions for cryogenic applications.

Valves for cryogenic service are supplied with austenitic stainless steel bodies and trim materials for good corrosion protection and minimal heat loss.

### TESTING:

Valves can be qualification tested at cryogenic temperatures with nitrogen or helium gas.

### SPECIAL CLEANING:

All cryogenic valves are thoroughly degreased, cleaned, and pipe ends sealed to prevent contamination.

### STANDARD TRIMS FOR CRYOGENIC SERVICE

FIGURE NO.	① BODY	③ DISC	② BODY SEAT	④ DISC SEAT	⑥ SPRING	WETTED PARTS <sup>(1)</sup>
_____- 13D10-3DB	A351 Gr. CF8M	A351 Gr. CF8M	Same as Body	Same as Disc	Inconel X-750	316 SS
_____- 13D19-3DB	A351 Gr. CF8M	A351 Gr. CF8M	Stellite overlay	Same as Disc	Inconel X-750	316 SS

(1) Wetted parts comprise the following components: Holders, Hinge Pin, Stop Pin, and Retainer Pins (part numbers 5, 7, 8 and 9).

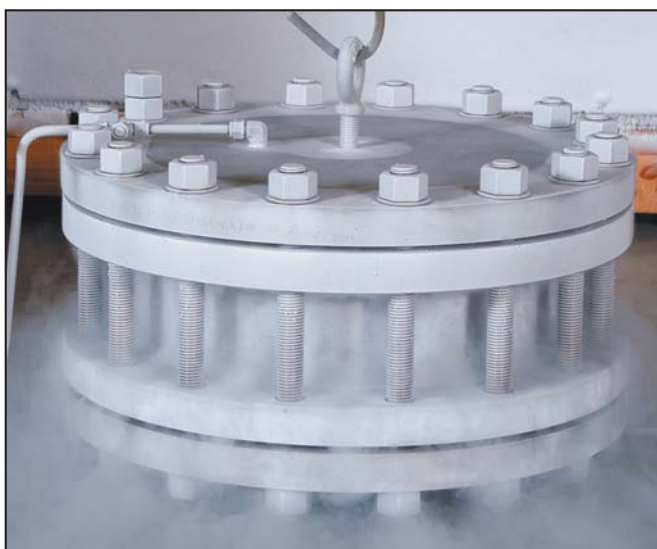
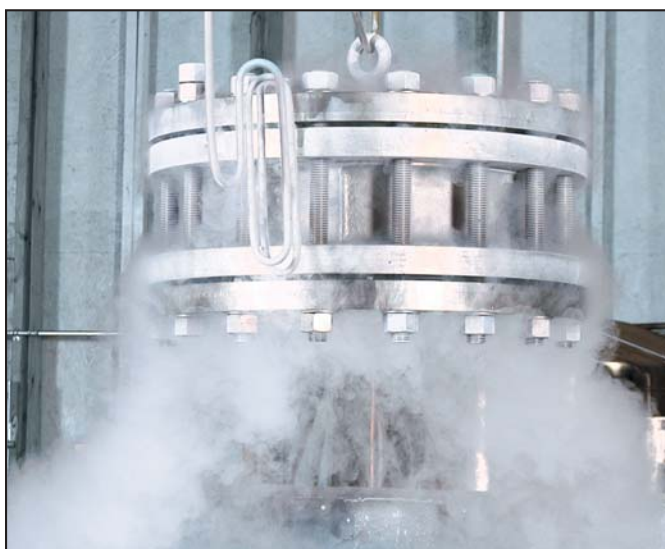

## SOUR GAS SERVICE

All Proquip Dual Plate Check valves can meet the material requirements of NACE when required.

For material selection and figure number designation please contact the factory.

## NUCLEAR SERVICE



Velan holds ASME N Certificate of authorization to manufacture nuclear valves and components in Classes I, II and III in its U.S. and Canadian plants. Strict quality control in all facets of procurement of material and production assures conformance to all ASME requirements for nuclear service.

For further information on valve selection please contact the factory.

# Cvs & CALCULATION OF FLOW DATA

SIZE		ASME CLASSES											
in	mm	150		300		600		900		1500		2500	
		C <sub>v</sub>	K <sub>v</sub>	C <sub>v</sub>	K <sub>v</sub>	C <sub>v</sub>	K <sub>v</sub>	C <sub>v</sub>	K <sub>v</sub>	C <sub>v</sub>	K <sub>v</sub>	C <sub>v</sub>	K <sub>v</sub>
2"	50	54	46	54	46	54	46	43	37	43	37	43	37
2½"	65	120	103	120	103	120	103	108	93	108	93	108	93
3"	80	130	112	130	112	130	112	122	104	122	104	122	104
4"	100	320	275	320	275	320	275	216	186	216	186	189	163
5"	125	650	559	650	559	650	559	500	431	500	431	400	345
6"	150	800	688	800	688	800	688	576	495	576	495	504	433
8"	200	1400	1204	1400	1204	1400	1204	1120	963	1120	963	980	843
10"	250	2600	2236	2600	2236	2600	2236	2080	1789	2080	1789	1820	1565
12"	300	3850	3311	3850	3311	3850	3311	3080	2649	3080	2649	2695	2318
14"	350	5000	4300	4500	3870	4500	3870	–	–	–	–	–	–
16"	400	7250	6235	6525	5612	6525	5612	–	–	–	–	–	–
18"	450	10000	8600	9000	7740	9000	7740	–	–	–	–	–	–
20"	500	12400	10664	11160	9598	11160	9598	–	–	–	–	–	–
24"	600	23000	19780	20700	17802	20700	17802	–	–	–	–	–	–
30"	750	40000	34400	36000	30960	32000	27520	–	–	–	–	–	–
36"	900	60000	51600	54000	46440	48000	41280	–	–	–	–	–	–

Note: Velan has established the above Cv results through a series of tests conducted at both in-house and sub-contracted test facilities, which have been combined with calculations to provide extrapolated test results. Velan engineering should be consulted for items not identified above.

## DATA FOR CALCULATION OF FLOW

The coefficient of flow C<sub>v</sub> expresses the rate of flow in gallons per minute at 60°F water with a pressure drop of 1 psi across the valve. The C<sub>v</sub> coefficients for the various types and sizes, shown in the tables, have been determined from actual flow tests.

**NOTE:** K<sub>v</sub> is the metric equivalent of C<sub>v</sub>.

$$K_v = C_v \times 0.85$$

### FOR LIQUIDS:

$$(1) \quad Q_L = C_v \sqrt{\frac{\Delta P}{G_L}}$$

$$(2) \quad \Delta P = G_L \left( \frac{Q_L}{C_v} \right)^2$$

WHERE: Q<sub>L</sub> = Flow in U.S. gallons per minute.  
 ΔP = (P<sub>1</sub>-P<sub>2</sub>) Pressure drop in psi  
 G<sub>L</sub> = Specific gravity of liquid (water = 1 at 60°F)

### FOR GASES:

$$(3) \quad Q_g = 1360 C_v \sqrt{\frac{\Delta P}{G_g T}} \cdot \sqrt{\frac{P_1 + P_2}{2}}$$

$$(4) \quad \Delta P = P_1 - \sqrt{P_1^2 - 2G_g T \left( \frac{Q_g}{1360 C_v} \right)^2}$$

WHERE: Q<sub>g</sub> = Volumetric flow of gas (SCFH)  
 G<sub>g</sub> = Specific gravity of gas at standard conditions (air at atmosphere and 60°F = 1)  
 T = Absolute temperature of gas (°F +460)

### FOR STEAM:

$$(5) \quad W = \frac{2.1}{1 + 0.0007 T_s} C_v \sqrt{\Delta P (P_1 + P_2)}$$

$$(6) \quad \Delta P = P_1 - \sqrt{P_1^2 - K^2}$$

WHERE:  $K = \left( \frac{1 + 0.0007 T_s}{2.1 C_v} \right) \cdot W$   
 W = Pounds per hour of steam  
 ΔP = (P<sub>1</sub>-P<sub>2</sub>) Pressure drop in psi  
 T<sub>s</sub> = Degree of superheat (°F)  
 P<sub>1</sub> = inlet pressure  
 P<sub>2</sub> = outlet pressure

**NOTE:** For saturated steam T<sub>s</sub> = 0

**NOTE:** For gas and steam, max. ΔP = ½ P<sub>1</sub>, and min. P<sub>2</sub> = ½ P<sub>1</sub>, and P<sub>1</sub>, P<sub>2</sub> are absolute pressures (psia)

# ASME B16.34 PRESSURE-TEMPERATURE RATINGS

## A216 Gr. WCB

TEMP. °F	WORKING PRESSURE by classes, psig						
	150	300	600	900	1500	2500	4500
100	285	740	1480	2220	3705	6170	11110
200	260	675	1350	2025	3375	5625	10120
300	230	655	1315	1970	3280	5470	9845
400	200	635	1270	1900	3170	5280	9505
500	170	600	1200	1795	2995	4990	8980
600	140	550	1095	1640	2735	4560	8210
650	125	535	1075	1610	2685	4475	8055
700	110	535	1065	1600	2665	4440	7990
750	95	505	1010	1510	2520	4200	7560
800	80	410	825	1235	2060	3430	6170
850 <sup>(1)</sup>	65	270	535	805	1340	2230	4010
900 <sup>(1)</sup>	50	170	345	515	860	1430	2570
950 <sup>(1)</sup>	35	105	205	310	515	860	1545
1000 <sup>(1)</sup>	20	50	105	155	260	430	770

(1) Permissible, but not recommended for prolonged usage above 800°F (427°C).

TEMP. °C	GAGE WORKING PRESSURE BY RATING NUMBER, bar						
	PN 20	PN 50	PN 100	PN 150	PN 250	PN 420	PN 760
38	19.6	51.1	102.1	153.2	255.3	425.5	765.8
50	19.2	50.1	100.2	150.2	250.4	417.3	751.1
100	17.7	46.4	92.8	139.1	231.9	386.5	695.7
150	15.8	45.2	90.5	135.7	226.1	376.9	678.4
200	14.0	43.8	87.6	131.5	219.1	365.2	657.3
250	12.1	41.7	83.4	125.2	208.6	347.7	625.8
300	10.2	38.7	77.5	116.2	193.7	322.8	581.0
350	8.4	37.0	73.9	110.9	184.8	308.0	554.4
375	7.4	36.5	72.9	109.4	182.3	303.9	547.0
400	6.5	34.5	69.0	103.5	172.5	287.5	517.5
425	5.6	28.8	57.5	86.3	143.8	239.6	431.4
450 <sup>(1)</sup>	4.7	20.0	40.1	60.1	100.2	166.9	300.5
475 <sup>(1)</sup>	3.7	13.5	27.1	40.6	67.7	112.9	203.2
500 <sup>(1)</sup>	2.8	8.8	17.6	26.4	44.0	73.3	131.9
525 <sup>(1)</sup>	1.9	5.2	10.4	15.5	25.9	43.2	77.7
540 <sup>(1)</sup>	1.3	3.3	6.5	9.8	16.3	27.2	48.9

## A351 Gr. CF8M<sup>(3)</sup>, A351 Gr. CF3M<sup>(2)</sup>

TEMP. °F	WORKING PRESSURE BY CLASSES, psig						
	150	300	600	900	1500	2500	4500
100	275	720	1440	2160	3600	6000	10800
200	235	620	1240	1860	3095	5160	9290
300	215	560	1120	1680	2795	4660	8390
400	195	515	1025	1540	2570	4280	7705
500	170	480	955	1435	2390	3980	7165
600	140	450	900	1355	2255	3760	6770
650	125	445	890	1330	2220	3700	6660
700	110	430	870	1305	2170	3620	6515
750	95	425	855	1280	2135	3560	6410
800	80	420	845	1265	2110	3520	6335
850	65	420	835	1255	2090	3480	6265
900	50	415	830	1245	2075	3460	6230
950	35	385	775	1160	1930	3220	5795
1000	20	350	700	1050	1750	2915	5245
1050 <sup>(3)</sup>	20 <sup>(1)</sup>	345	685	1030	1720	2865	5155
1100 <sup>(3)</sup>	20 <sup>(1)</sup>	305	610	915	1525	2545	4575
1150 <sup>(3)</sup>	20 <sup>(1)</sup>	235	475	710	1185	1970	3550
1200 <sup>(3)</sup>	20 <sup>(1)</sup>	185	370	555	925	1545	2775
1250 <sup>(3)</sup>	20 <sup>(1)</sup>	145	295	440	735	1230	2210
1300 <sup>(3)</sup>	20 <sup>(1)</sup>	115	235	350	585	970	1750
1350 <sup>(3)</sup>	20 <sup>(1)</sup>	95	190	290	480	800	1440
1400 <sup>(3)</sup>	20 <sup>(1)</sup>	75	150	225	380	630	1130
1450 <sup>(3)</sup>	20 <sup>(1)</sup>	60	115	175	290	485	875
1500 <sup>(3)</sup>	20 <sup>(1)</sup>	40	85	125	205	345	620

(1) For welding end valves only. Flanged end ratings terminate at 1000°F (538°C).

(2) CF3M: Not to be used over 850°F (454°C).

(3) At temperatures over 1000°F (538°C), use only when the carbon content is 0.04% or higher.

TEMP. °C	GAGE WORKING PRESSURE BY RATING NUMBER, bar						
	PN 20	PN 50	PN 100	PN 150	PN 250	PN 420	PN 760
38	19.0	49.7	99.3	149.0	248.3	413.8	744.8
50	18.3	48.1	96.3	144.4	240.6	401.0	721.9
100	16.1	42.3	84.6	126.8	211.0	351.7	633.2
150	14.8	38.6	77.1	115.7	192.4	320.8	577.7
200	13.6	35.8	71.2	107.0	178.5	297.2	535.2
250	12.0	33.5	66.8	100.3	167.0	278.2	500.8
300	10.2	31.6	63.1	95.0	158.1	263.6	474.6
350	8.3	30.4	61.0	91.3	152.3	253.9	456.9
375	7.4	29.6	59.9	89.7	149.3	249.1	448.3
400	6.5	29.3	59.0	88.2	147.2	245.4	441.9
425	5.6	29.0	58.3	87.3	145.6	242.9	437.2
450	4.6	29.0	57.7	86.7	144.3	240.4	432.8
475	3.7	28.7	57.3	86.1	143.4	239.0	430.3
500	2.8	27.3	54.8	82.1	136.7	228.0	410.5
525	1.9	25.2	50.6	75.9	126.4	210.7	379.2
550 <sup>(3)</sup>	1.4 <sup>(1)</sup>	24.0	47.8	71.8	119.8	199.5	359.0
575 <sup>(3)</sup>	1.4 <sup>(1)</sup>	22.8	45.4	68.3	114.1	191.0	341.9
600 <sup>(3)</sup>	1.4 <sup>(1)</sup>	19.9	39.9	59.7	99.5	166.0	298.6
625 <sup>(3)</sup>	1.4 <sup>(1)</sup>	15.7	31.7	47.4	79.2	131.7	237.3
650 <sup>(3)</sup>	1.4 <sup>(1)</sup>	12.6	25.3	37.9	63.2	105.7	189.8
675 <sup>(3)</sup>	1.4 <sup>(1)</sup>	10.1	20.6	30.8	51.4	86.1	154.8
700 <sup>(3)</sup>	1.4 <sup>(1)</sup>	8.3	16.9	25.1	42.0	69.8	125.8
725 <sup>(3)</sup>	1.4 <sup>(1)</sup>	6.9	13.9	21.1	35.0	58.2	104.9
750 <sup>(3)</sup>	1.4 <sup>(1)</sup>	5.7	11.3	17.1	28.7	47.7	85.7
775 <sup>(3)</sup>	1.4 <sup>(1)</sup>	4.6	9.0	13.7	22.8	38.1	68.4
800 <sup>(3)</sup>	1.4 <sup>(1)</sup>	3.5	7.0	10.6	17.4	29.2	52.6

## A352 Gr. LCC

TEMP. °F	WORKING PRESSURE BY CLASSES, psig						
	150	300	600	900	1500	2500	4500
-20 to 100	290	750	1500	2250	3750	6250	11250
200	260	750	1500	2250	3750	6250	11250
300	230	730	1455	2185	3640	6070	10925
400	200	705	1405	2110	3520	5865	10555
500	170	665	1330	1995	3325	5540	9965
600	140	605	1210	1815	3025	5040	9070
650	125	590	1175	1765	2940	4905	8825
700	110	555	1110	1665	2775	4630	8330
750	95	505	1015	1520	2535	4230	7610
800	80	410	825	1235	2055	3430	6170
850	65	320	640	955	1595	2655	4785
900	50	225	445	670	1115	1855	3345
950	35	135	275	410	685	1145	2055
1000	20	85	170	255	430	715	1285

TEMP. °C	GAGE WORKING PRESSURE BY RATING NUMBER, bar						
	PN 20	PN 50	PN 100	PN 150	PN 250	PN 420	PN 760
-29 to 38	19.8	51.7	103.4	155.1	258.6	430.9	775.7
50	19.5	51.7	103.4	155.1	258.6	430.9	775.7
100	17.7	51.5	103.0	154.6	257.6	429.4	773.0
150	15.8	50.2	100.3	150.5	250.8	418.1	752.6
200	13.8	48.6	97.2	145.8	243.2	405.4	729.7
250	12.1	46.3	92.7	139.0	231.8	386.2	694.8
300	10.2	42.9	85.7	128.6	214.4	357.1	642.6
325	9.3	41.4	82.6	124.0	206.6	344.3	619.6
350	8.4	40.0	80.0	120.1	200.1	333.5	600.3
375	7.4	37.8	75.7	113.5	189.2	315.3	567.5
400	6.5	34.7	69.4	104.2	173.6	289.3	520.8
425	5.5	28.8	57.5	86.3	143.8	239.7	431.5
450	4.6	23.0	46.0	69.0	115.0	191.7	345.1
475	3.7	17.1	34.2	51.3	85.4	142.4	256.3
500	2.8	11.6	23.2	34.7	57.9	96.5	173.7
538	1.4	5.9	11.8	17.7	29.5	49.2	88.6

# SPECIFICATION OF VALVE MATERIALS

## TYPICAL BODY, DISC, HOLDER AND PIN MATERIALS

DESCRIPTION		CARBON STEEL		ALLOY STEEL				STAINLESS STEEL				BAR STOCK	
				1% CR ½ Mo	2% CR-1 Mo	5 CR	9 CR-1Mo	13 CR	316	316L	304	13 CR	SS
ASTM DESIGNATION		A216 WCB	A352 LCC	A217 WC6	A217 WC9	A217 C5	A217 C12	A217 CA15	A351 CF8M	A351 CF3M	A351 CF8	A479 410 <sup>(1)</sup>	A 479 316
COMPOSITION %	Carbon	0.25 <sup>(1)</sup>	0.25	0.20	0.18	0.20	0.20	0.15	0.08	0.03	0.08	0.15	0.08
	Manganese	1.00	1.20	0.50-0.80	0.40-0.70	0.40-0.70	0.35-0.65	1.00	1.50	1.50	1.50	1.00	2.00
	Phosphorus	0.04	0.04	0.04	0.40	0.04	0.04	0.04	0.04	0.04	0.04	0.040	0.045
	Sulphur	0.045	0.045	0.045	0.045	0.045	0.045	0.040	0.040	0.040	0.040	0.030	0.030
	Silicon	0.60	0.60	0.60	0.60	0.75	1.00	1.50	1.50	1.50	2.00	1.00	1.00
	Nickel	0.50	0.50	0.50	0.50	0.50	0.50	1.00	9.00-12.00	9.00-13.00	8.00-11.00	—	10.00-14.00
	Chromium	0.50	0.50	1.00-1.50	2.00-2.75	4.00-6.50	8.00-10.00	11.5-14.0	18.00-21.00	17.00-21.00	18.00-21.00	11.50-13.50	16.00-18.00
	Molybdenum	0.20	0.20	0.45-0.65	0.90-1.20	0.45-0.65	0.90-1.20	0.50	2.0-3.00	2.0-3.00	0.50	—	2.00-3.00
Copper	0.30	0.30	0.50	—	0.50	0.50	—	—	—	—	—	—	
Heat Treat.	Anneal	Quench & Temper	Temper	Temper	Temper	Temper	Solution anneal				Class 2	Sol. Ann.	
Tensile psi min.	70,000	70,000-95,000	70,000-90,000	70,000-90,000	90,000-115,000	90,000-115,000	90,000-115,000	70,000	70,000	70,000	110,000	75,000	
Yield psi min.	36,000	40,000	40,000	40,000	60,000	60,000	65,000	30,000	30,000	30,000	85,000	30,000	
Elong. % Min.	22	22	20	20	18	18	18	30	30	35	15	30	
R. Area % Min.	35	35	35	35	35	35	30	—	—	—	45	40	
Hardness HB	187 max.	200 max.	207 max.	207 max.	241 max.	241 max.	327-381	—	187 max.	—	269 max.	—	

(1) Velan standard: 0.25 or less.

## BOLT CIRCLE DIAMETER DATA

The additional Bolt Circle Diameter Data below may be used in conjunction with Dimensional Data found on pages 10–18

(Source: ASME B16.5 for valves 2–24", and ASME B16.47 Series A for valves larger than 24")

SIZE		ASME CLASSES											
NPS	DN	150		300		600		900		1500		2500	
		in	mm	in	mm	in	mm	in	mm	in	mm	in	mm
2"	50	4.75	121	5.00	127	5.00	127	6.50	165	6.50	165	6.75	171
2½"	65	5.50	140	5.88	149	5.88	149	7.50	191	7.50	191	7.75	197
3"	80	6.00	152	6.63	168	6.62	168	7.50	191	8.00	203	9.00	229
4"	100	7.50	191	7.88	200	8.50	216	9.25	235	9.50	241	10.75	273
5"	125	8.50	216	9.25	235	10.50	267	11.00	279	11.50	292	12.75	324
6"	150	9.50	241	10.63	270	11.50	292	12.50	318	12.50	318	14.50	368
8"	200	11.75	298	13.00	330	13.75	349	15.50	394	15.50	394	17.25	438
10"	250	14.25	362	15.25	387	17.00	432	18.50	470	19.00	483	21.25	540
12"	300	17.00	432	17.75	451	19.25	489	21.00	533	22.50	572	24.38	619
14"	350	18.75	476	20.25	514	20.75	527	22.00	559	25.00	635	—	—
16"	400	21.25	540	22.50	572	23.75	603	24.25	616	27.75	705	—	—
18"	450	22.75	578	24.75	629	25.75	654	27.00	686	30.50	775	—	—
20"	500	25.00	635	27.00	686	28.50	724	29.50	749	32.75	832	—	—
24"	600	29.50	749	32.00	813	33.00	838	35.50	902	39.00	991	—	—
26"	650	31.75	806	34.50	876	36.00	914	37.50	953	—	—	—	—
28"	700	34.00	864	37.00	940	38.00	965	40.25	1022	—	—	—	—
30"	750	36.00	914	39.25	997	40.25	1022	42.75	1086	—	—	—	—
32"	800	38.50	978	41.50	1054	42.50	1080	45.50	1156	—	—	—	—
36"	900	42.75	1086	46.00	1168	47.00	1194	50.75	1289	—	—	—	—
40"	1000	47.25	1200	45.50	1156	47.75	1213	52.75	1340	—	—	—	—
42"	1050	49.50	1257	47.50	1207	50.50	1283	54.75	1391	—	—	—	—
48"	1200	56.00	1422	54.00	1372	57.50	1461	62.50	1588	—	—	—	—
54"	1350	62.75	1594	61.00	1549	64.25	1632	—	—	—	—	—	—
60"	1500	69.25	1759	67.00	1702	71.75	1822	—	—	—	—	—	—

# INSTALLATION/SERVICE RECOMMENDATIONS

## CHECK VALVES

Dual Plate Check Valves must be installed with the arrow in the direction of the normal flow. This must be checked carefully before installing the valve. Placing a check valve in the opposite direction to the flow will prevent the disc from operating in the intended manner.

The preferred orientation is vertical upward flow or horizontal. The valve may be installed in other orientations, but any deviation from vertical or horizontal is a compromise to the design of the valve. Installation upside-down is not recommended. If installed horizontal, pins **MUST** be vertical.

NOTE: Before installation remove the rust preventive coating with any hydrocarbon solvent, such as kerosene, varsol etc.





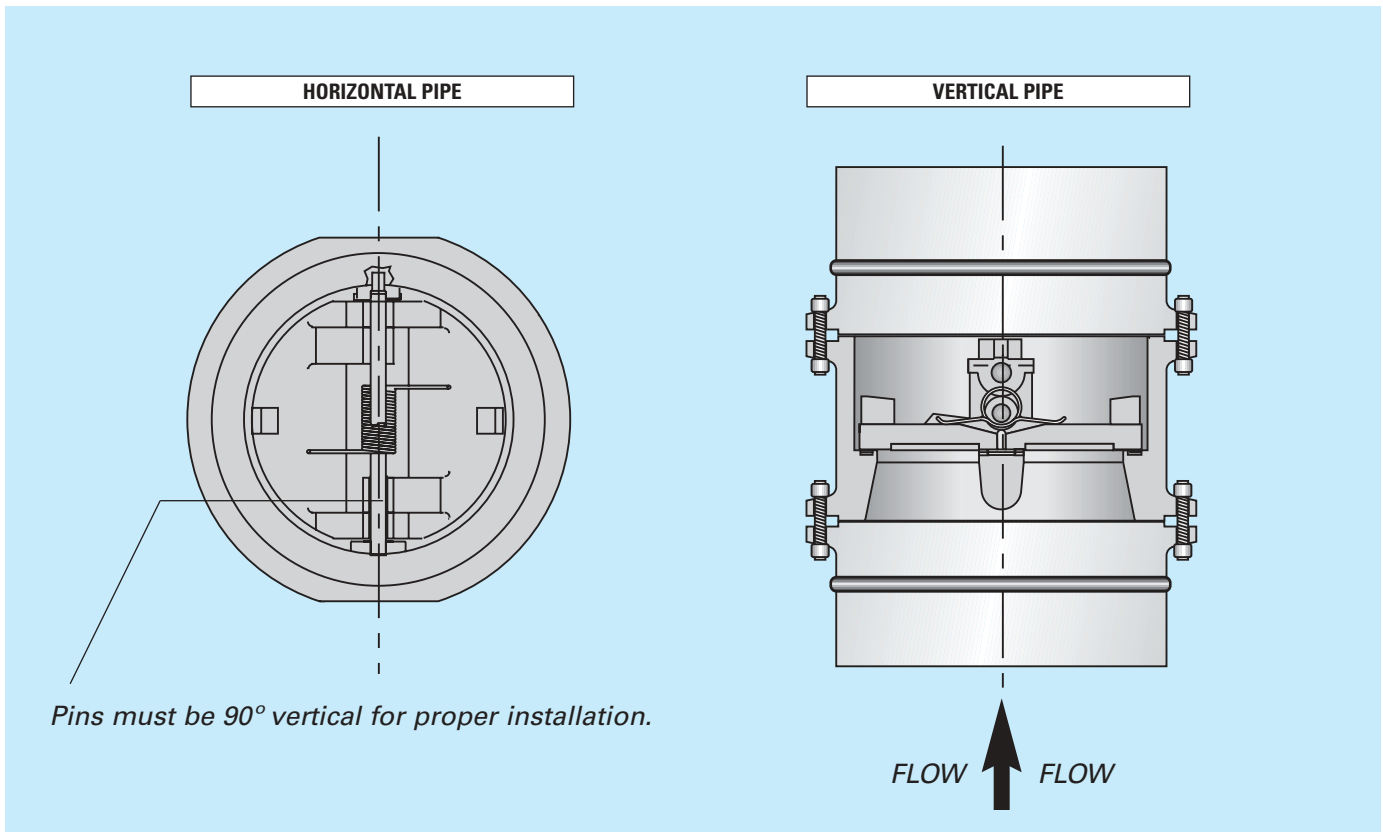







NOTE: All check valves should be installed at least ten pipe diameters away from upstream pumps, elbows, fittings or equipment. If closer installation is required, please consult Velan's Field Engineering Services Department.

## ACCEPTABLE INSTALLATION ORIENTATIONS



For further information please consult *Velan's Proquip Dual Plate installation and operation manual.*

# HOW TO ORDER DUAL PLATE CHECK VALVES

VALVE TYPE	SIZE	PRESSURE RATING	BODY MATERIAL	DISC MATERIAL	SEATING SURFACES	SPRING	WETTED PARTS	END CONNECTION
A	B	C	D	E	F	G	H	I
 	 		 		 			
<b>P</b> <b>W</b>	<b>1</b> <b>2</b>	<b>2</b>	<b>0</b> <b>2</b>	<b>D</b>	<b>1</b> <b>7</b>	<b>3</b>	<b>D</b>	<b>B</b>

**Example:** 4" wafer type dual plate check valve, ASME Class 600, WCB body, CF8M disc, 316 stainless steel seating surfaces, Inconel X-750 springs, 316 SS wetted parts, and raised face with 175-250 AARH finish on end facing.

A DUAL PLATE CHECK VALVE TYPE			
<b>PF</b> - Double flange, drilled through construction <b>PG</b> - Double flange, tapped construction <b>PH</b> - Hub end connection, drilled through construction <b>PL</b> - Solid lug, threaded construction <b>PM</b> - Solid lug, drilled through construction <b>PT</b> - Wafer (Cast Iron, Ductile Iron only) <b>PW</b> - Wafer <b>PZ</b> - Butt Weld end connection			
B SIZE OF CONNECTION			
Customers have the choice of specifying valve size as part of the valve figure number ( <b>B</b> ) using the numbers below, or indicating valve size separately. <b>EXAMPLES:</b> PW12-202D17-3DB (valve size is part of figure number) 4" PW-202D17-3DB (valve size is shown separately)			
<b>08</b> - 2" (50 mm) <b>09</b> - 2½" (65 mm) <b>10</b> - 3" (80 mm) <b>12</b> - 4" (100 mm) <b>13</b> - 5" (125 mm) <b>14</b> - 6" (150 mm) <b>15</b> - 8" (200 mm) <b>16</b> - 10" (250 mm) <b>18</b> - 12" (300 mm) <b>19</b> - 14" (350 mm) <b>20</b> - 16" (400 mm) <b>21</b> - 18" (450 mm)	<b>22</b> - 20" (500 mm) <b>23</b> - 22" (550 mm) <b>24</b> - 24" (600 mm) <b>26</b> - 26" (650 mm) <b>28</b> - 28" (700 mm) <b>30</b> - 30" (750 mm) <b>32</b> - 32" (800 mm) <b>34</b> - 34" (850 mm) <b>36</b> - 36" (900 mm) <b>40</b> - 40" (1000 mm) <b>42</b> - 42" (1050 mm) <b>44</b> - 44" (1100 mm)	<b>46</b> - 46" (1150 mm) <b>48</b> - 48" (1200 mm) <b>50</b> - 50" (1250 mm) <b>52</b> - 52" (1300 mm) <b>54</b> - 54" (1350 mm) <b>56</b> - 56" (1400 mm) <b>58</b> - 58" (1450 mm) <b>60</b> - 60" (1500 mm)	<b>API 6A SIZES:</b> <b>AA</b> - 2½" <b>AJ</b> - 2¾" <b>BB</b> - 3½" <b>CA</b> - 4½" <b>DB</b> - 5½" <b>EA</b> - 7½" <b>GO</b> - 9" <b>JO</b> - 11" <b>LK</b> - 13⅝" <b>PM</b> - 16¾" <b>TM</b> - 20¾"
C PRESSURE RATING			
<b>0</b> - ASME 150 <b>1</b> - ASME 300 <b>2</b> - ASME 600 <b>3</b> - ASME 1500	<b>4</b> - ASME 2500 <b>5</b> - ASME 4500 <b>6</b> - ASME 400 <b>7</b> - ASME 900	<b>A</b> - ASME 125 <b>B</b> - ASME 250 <b>C</b> - API 2000 <b>D</b> - API 3000	<b>E</b> - API 5000 <b>F</b> - API 10000
D BODY MATERIAL			
<b>02</b> - ASTM A216 Gr. WCB <b>04</b> - ASTM A217 Gr. C5 <b>05</b> - ASTM A217 Gr. WC6 <b>06</b> - ASTM A217 Gr. WC9 <b>07</b> - ASTM A126 Gr. B Cast Iron <b>09</b> - ASTM A217 Gr. C12 <b>11</b> - ASTM A351 Gr. CF8 <b>13</b> - ASTM A351 Gr. CF8M <b>15</b> - ASTM A351 Gr. CF8C <b>17</b> - ASTM A536 Ductile Iron 60/40/18 <b>19</b> - ASTM A494 Gr. M35-1 <b>21</b> - ASTM A494 Gr. CW12MW/ UNS N10276 <b>23</b> - ASTM A351 Gr. CN7M <b>26</b> - ASTM A350 Gr. LF2 <b>30</b> - ASTM A217 Gr. CA15 <b>31</b> - ASTM A352 Gr. LCC	<b>32</b> - ASTM A890 Gr. 4A / UNS S31803- 22% Cr. Duplex <b>33</b> - ASTM A494 Gr. CW6MC / UNS N06625 <b>35</b> - ASTM A351 Gr. CK3MCuN/ UNS S31254 - 6% Moly <b>40</b> - ASTM B367 Gr. C2 <b>45</b> - ASTM A890 Gr. 6A / UNS S32760 <b>48</b> - ASTM A890 Gr. 5A / UNS S32750 - 25% Cr. Duplex <b>52</b> - ASTM B148 Gr. C95800 - Nickel Aluminum-Bronze <b>53</b> - ASTM A352 Gr. CA6NM		

E DISC MATERIAL		
<b>A</b> - Cast Iron <b>B</b> - ASTM A216 Gr. WCB <b>C</b> - Ductile Iron <b>D</b> - ASTM A351 Gr. CF8M <b>E</b> - ASTM A217 Gr. CA15 <b>F</b> - ASTM A494 CU5MCuC <b>G</b> - ASTM A494 Gr. CW12MW / UNS N10276 <b>H</b> - ASTM B148 Gr. C95800 - Nickel Aluminum-Bronze <b>J</b> - ASTM A494 Gr. CW6MC / UNS N06625 <b>K</b> - ASTM B367 Gr. C2 <b>L</b> - ASTM A352 Gr. LCC	<b>M</b> - ASTM A494 Gr. M35-1 <b>N</b> - ASTM A352 Gr. CA6NM <b>P</b> - ASTM A217 Gr. WC9 <b>Q</b> - ASTM A351 Gr. CN7M <b>R</b> - ASTM A890 Gr. 4A/UNS S31803-22% Cr. Duplex <b>S</b> - ASTM A890 Gr. 5A/UNS S32750-25% Cr. Duplex <b>T</b> - ASTM A351 Gr. CF8 <b>U</b> - ASTM A217 Gr. C5 <b>V</b> - ASTM A217 Gr. C12 <b>W</b> - ASTM A351 Gr. CF8C <b>X</b> - Special, as per P.O. <b>Y</b> - ASTM A217 Gr. WC6 <b>Z</b> - ASTM A351 Gr. CK3MCuN/ UNS S31254-6% Moly	
F SEATING SURFACES		
<b>Body seating surface only</b> <b>10</b> - Same as Body <b>11</b> - Buna-N® <b>12</b> - Neoprene® <b>13</b> - Viton A® <b>14</b> - Silicone® <b>15</b> - Teflon® <b>16</b> - Hastelloy <b>17</b> - 316 Stainless Steel <b>18</b> - 410 Stainless Steel <b>19</b> - Stellite® <b>20</b> - Monel® <b>21</b> - EPDM® <b>22</b> - Inconel 625 <b>23</b> - 304 Stainless Steel <b>28</b> - Viton B®		
<b>Disc seating surface only</b> <b>10</b> - Same as Disc <b>11</b> - Buna-N® <b>12</b> - Neoprene® <b>13</b> - Viton A® <b>14</b> - Silicone® <b>15</b> - Teflon® <b>16</b> - Hastelloy <b>17</b> - 316 Stainless Steel <b>18</b> - 410 Stainless Steel <b>19</b> - Stellite® <b>20</b> - Monel® <b>21</b> - EPDM® <b>22</b> - Inconel 625 <b>23</b> - 304 Stainless Steel <b>28</b> - Viton B®		
<b>Body and Disc seating surfaces</b> <b>86</b> - Hastelloy <b>87</b> - 316 Stainless Steel <b>88</b> - 410 Stainless Steel <b>89</b> - Stellite® <b>92</b> - Stellite® Body seat and 410 SS Disc seat <b>93</b> - Stellite® Body seat and 316 SS Disc seat		
G SPRING MATERIAL		
<b>1</b> - 316 Stainless Steel <b>2</b> - Inconel 600® <b>3</b> - Inconel X-750®	<b>4</b> - Monel 400® <b>5</b> - Inconel 718® <b>6</b> - Hastelloy C276®	<b>7</b> - Inconel 625® <b>8</b> - Carpenter 20® <b>0</b> - Special
H WETTED PARTS (1)		
<b>D</b> - 316 Stainless Steel <b>E</b> - 410 Stainless Steel <b>G</b> - Hastelloy C276® <b>J</b> - UNS N06625/Inconel 625® <b>K</b> - Titanium <b>M</b> - UNS N04400/Monel 400® <b>Q</b> - UNS N08020 / Alloy 20	<b>R</b> - UNS S31803 / 22% Cr. Duplex <b>S</b> - UNS S32750 / S32760 / 25% Cr. Duplex <b>T</b> - 304 Stainless Steel <b>W</b> - 347 Stainless Steel <b>Z</b> - UNS S31254 / 6% Moly.	
I END CONNECTION		
<b>A</b> - Raised Face, 125 - 175 AARH finish (Smooth) <b>B</b> - Raised Face, 175 - 250 AARH finish (Standard) <b>C</b> - Ring Type Joint <b>H</b> - Hub End (specify model and joint size) <b>J</b> - Raised Face, 250 - 500 AARH finish <b>N</b> - Flat Face, 125 - 175 AARH finish (Smooth) <b>P</b> - Flat Face, 175 - 250 AARH finish <b>W</b> - Weld End (specify pipe wall thickness)		

(1) Wetted parts comprise the following components: Holders, Hinge Pin, Stop Pin and Retainer Pins.

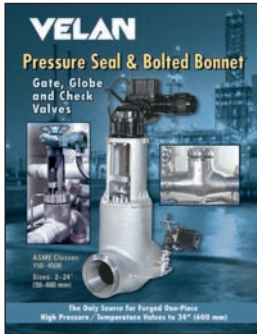

VEL-PS

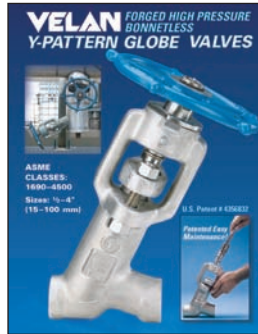

VEL-BG



VEL-SFV



VEL-BS



VEL-CRYO

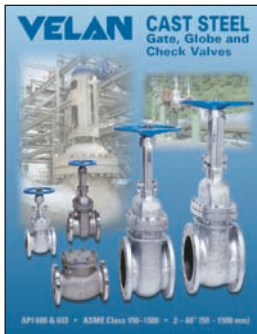

VEL-CSV

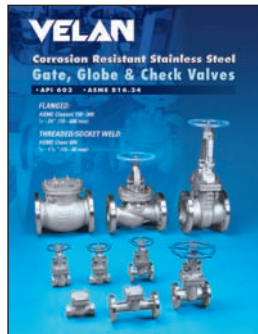

VEL-API-603

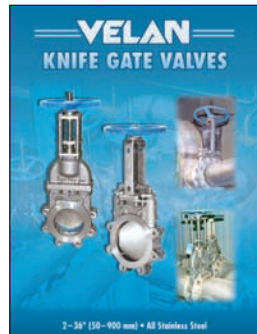

VEL-KGV



VEL-POCV

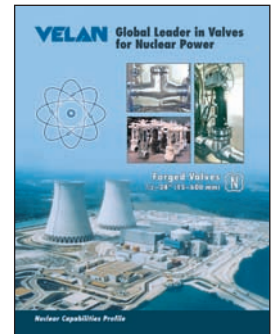

VEL-NCP

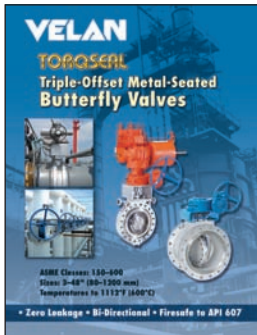

VEL-BF



VEL-MS

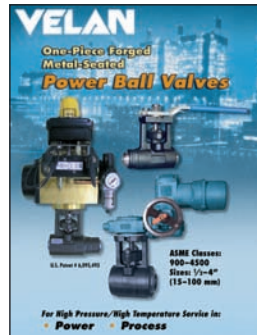

VEL-PBV

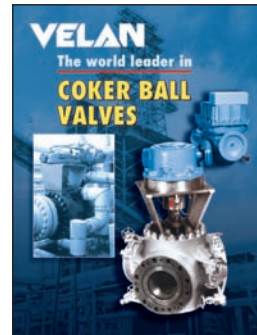

VEL-CBV

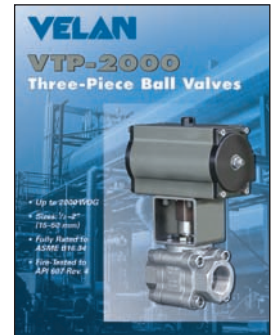

VEL-VTP



VEL-BV

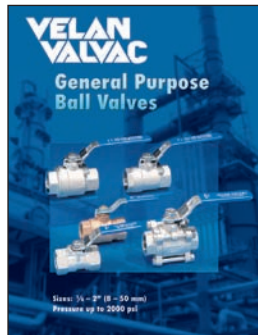

VEL-GPBV



VEL-SAS-BF

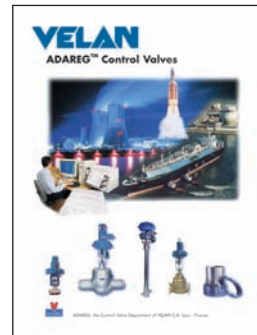

VEL-ADCV

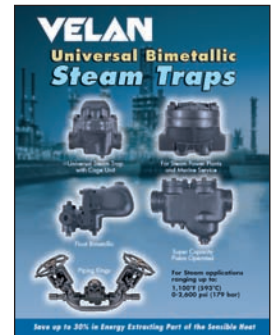

VEL-ST