



**YORK MILLENNIUM™ YIA
STEAM CHILLER**

WIRING DIAGRAM

Supersedes: 155.16-W1 (794)

Form 155.16-W1 (197)

**FOR MODELS:
YIA-ST-1A1 THRU YIA-ST-14F3
AND
YIA-HW-1A1 THRU YIA-HW-14F3
(50 AND 60 HERTZ)
120 TONS THRU 1377 TONS**

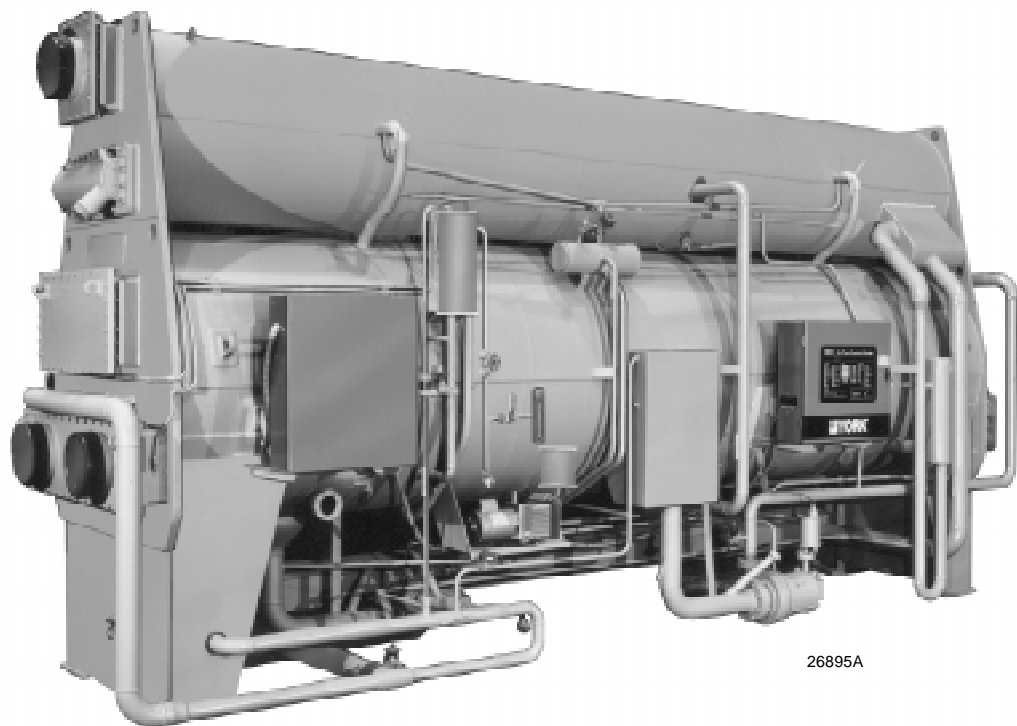

26895A

MILLENNIUM CONTROL CENTER ELEMENTARY DIAGRAM

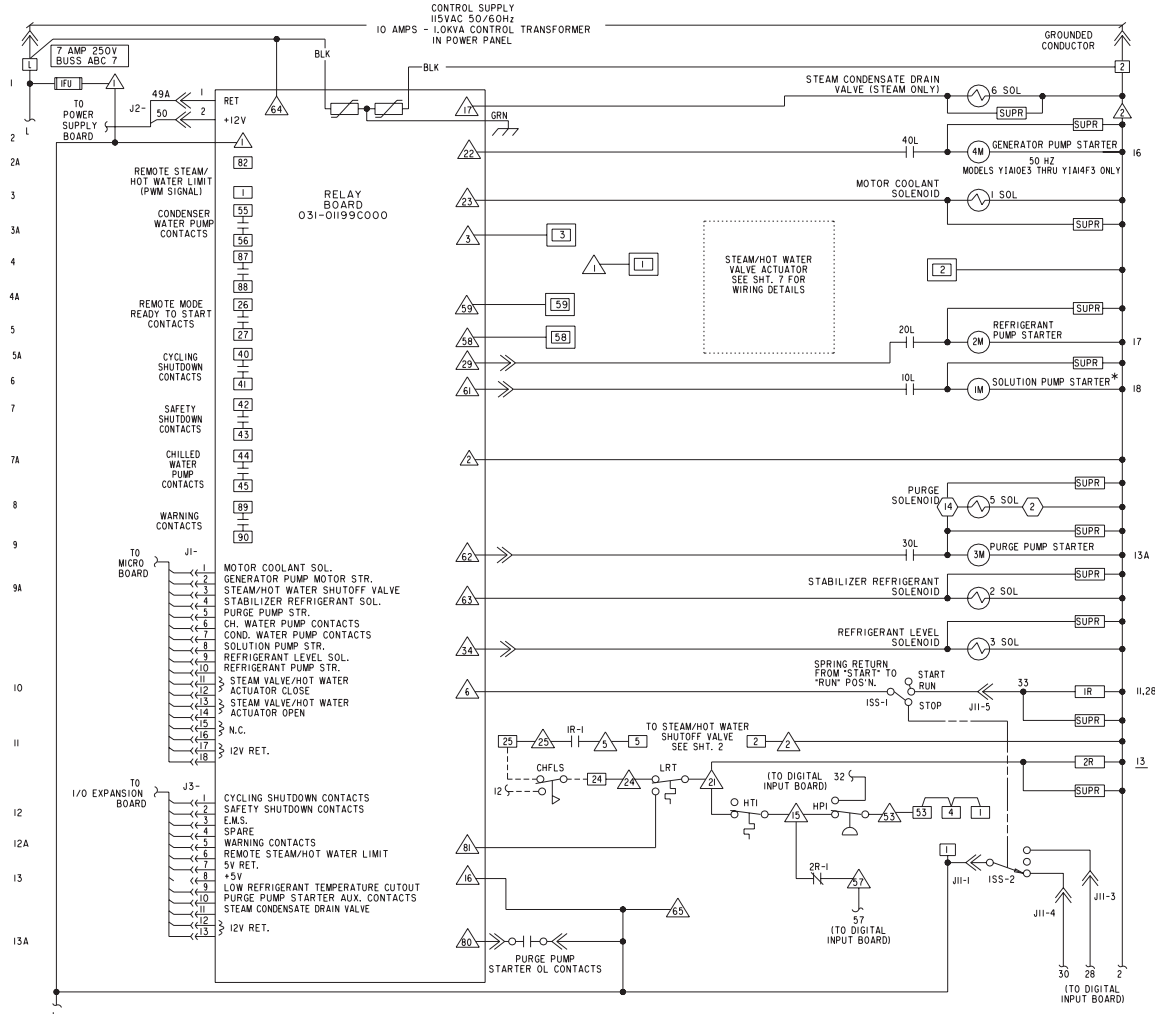

LD01208

MILLENNIUM CONTROL CENTER ELEMENTARY DIAGRAM (CONT'D.)

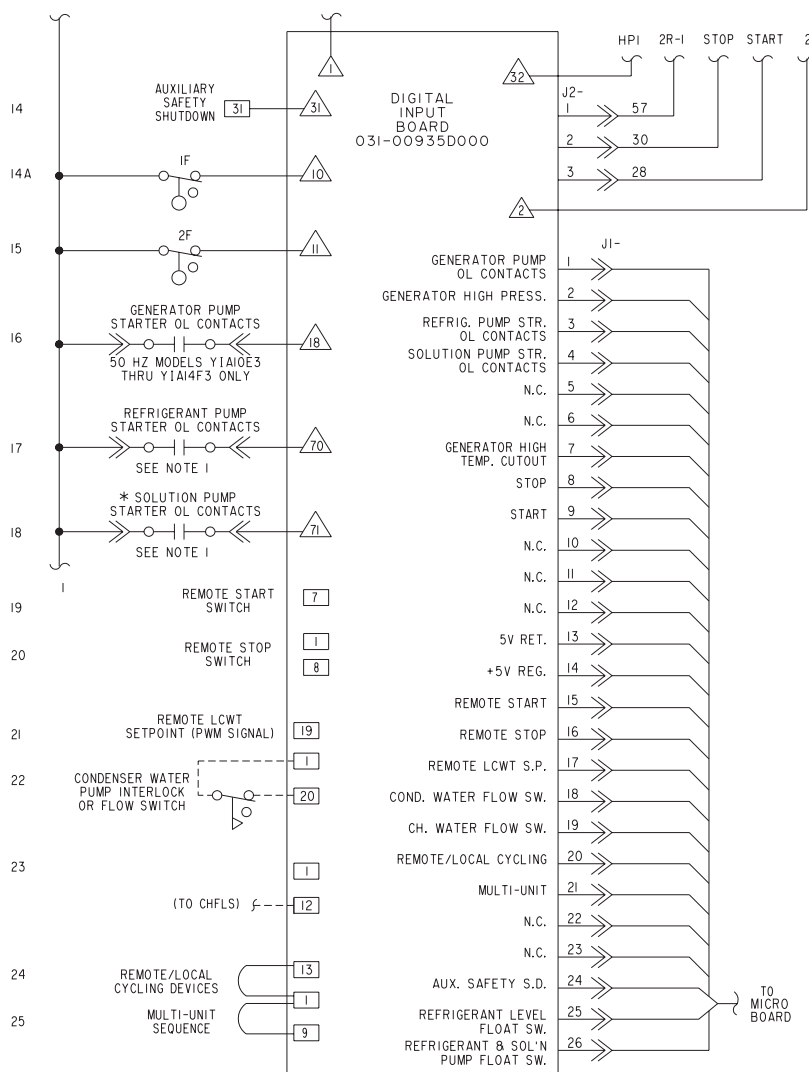

LD01209



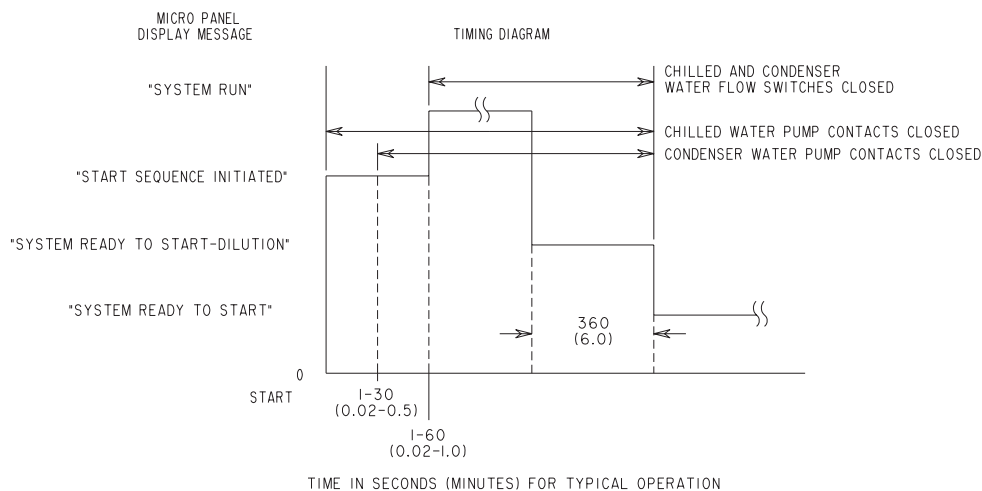







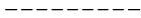
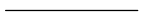

TIMING DIAGRAM

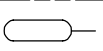

LD01210

MILLENNIUM CONTROL CENTER ELEMENTARY DIAGRAM (CONT'D.)

LEGEND

1F	REFRIGERANT LEVEL FLOAT SWITCH		
2F	REFRIGERANT & SOLUTION PUMP MOTOR COOLANT FLOAT SWITCH		
IM	3 PHASE SOLUTION PUMP STARTER (MOUNTED IN POWER PANEL)		
	ABSORBER PUMP STARTER ON 50 HZ MODELS (Y1A10E3 THRU Y1A14F3) ONLY		
2M	3 PHASE REFRIGERANT PUMP MOTOR STARTER (MOUNTED IN POWER PANEL)		
3M	3 PHASE PURGE PUMP MOTOR STARTER (MOUNTED IN POWER PANEL)		
4M	GENERATOR PUMP MOTOR STARTER (MOUNTED IN POWER PANEL)		
	(50 HZ MODELS Y1A10E3 THRU Y1A14F3 ONLY)		
IR	STEAM/HOT WATER SHUTOFF SOLENOID VALVE CONTROL RELAY		
2R	FIRST STAGE GENERATOR HIGH TEMP. CUT-OUT RELAY		
1SOL	MOTOR COOLANT SOLENOID		
2SOL	STABILIZER REFRIGERANT SOLENOID		
3SOL	REFRIGERANT LEVEL SOLENOID		
4SOL	STEAM/HOT WATER SHUTOFF SOLENOID		
5SOL	PURGE SOLENOID		
6SOL	STEAM CONDENSATE DRAIN VALVE SOLENOID (STEAM ONLY)		
ISS	DPDT 3 POSITION ROCKER SWITCH		
IT	CLASS 2 POWER SUPPLY TRANSFORMER		
CHFLS	CHILLED WATER FLOW SWITCH CUT-OUT (BY YORK/WIRING BY OTHERS)		
FU	FUSE		
HT	STEAM OR HOT WATER SUPPLY TEMPERATURE		FIELD WIRING
HT1	HIGH TEMPERATURE CUTOUT SWITCH		FACTORY WIRING
HP1	GENERATOR HIGH PRESSURE CUT-OUT SWITCH		CIRCUIT BOARD OR ENCLOSURE BOUNDARY
HP2	STEAM SUPPLY PRESSURE TRANSDUCER		JACK (J1,J2,...)
LRT	LOW REFRIGERANT TEMPERATURE CUT-OUT SWITCH		JACK (P1,P2,...)
LWT	LOW WATER TEMPERATURE CUT-OUT (PROVIDED BY RTI)		WIRE ENTRANCE HOLE IN CONTROL PANEL
MOV	METAL OXIDE VARISTOR		OPTION (WHEN SUPPLIED) BY YORK.
OL	MOTOR OVERLOAD		MECHANICAL LINKAGE
PT1,PT2-PT4	PRESSURE TRANSDUCER		SHIELDED CABLE
RT1-RT9	RESISTANCE TEMPERATURE SENSING ELEMENT		METAL OXIDE VARISTOR
<u>SUPR</u>	TRANSIENT SUPPRESSOR		
TB1,TB3,TB6	TERMINAL BLOCK, FACTORY WIRING - 		
TB2,TB4,TB5	TERMINAL BLOCK, FIELD CONNECTION - 		
TB7	TERMINAL BLOCK, FIELD CONNECTION, STEAM VALVE ACTUATOR - 		
	TERMINAL BLOCK LOCATED IN POWER PANEL		

NOTES

- This wiring diagram describes the standard electronic control scheme. Refer to the power panel wiring diagram for additional information. For details of standard modifications, refer to product Form 155.16-PA1.
- Field wiring to be in accordance with the National Electrical Code as well as all other applicable codes and specifications.
- Numbers along the left side of diagram are line identification numbers. The numbers along the right side indicate the line number location of relay contacts. An underlined contact location signifies a normally closed contact.
- Main control panel Class 1 field wiring terminal connection points are indicated by numbers within a rectangle, i.e. 15. Main control panel factory wiring terminals connection points are indicated by numbers within a triangle, i.e. 2. Component terminal markings are indicated by numbers within a circle, i.e. C1. Numbers adjacent to circuit lines are the circuit identification numbers.
- To cycle unit on and off automatically with contacts other than those shown, install a cycling device between terminals 1 & 13 (Line 24) (See note 7). If a cycling device is installed, jumper must be removed between terminals 1 & 13.
- To stop unit and not permit it to start again, install a stop device between terminals 1 & 8 (Line 20) (See note 7). A remote start-stop switch may be connected to terminals 1, 7 & 8 (Lines 19 & 20) (See note 7). Remote start-stop switch (Lines 19 & 20) is operative only in the "RE-MOTE" operating mode.
- Device contact rating to be 5 milliamperes at 115 volts A.C.
- Contact rating is 5 amps resistive at 120 volts A.C. or 240 volts A.C.
- Maximum allowable current draw is 1 amp holding, 10 amps inrush for 115 VAC field-supplied steam shutoff valve (Line 27).
- Contact rating is 5 amps resistive at 250 volts A.C. & 30 volts D.C., 2 amp inductive (0.4 PF) at 250 volts A.C. & 30 volts D.C.
- Each 115 VAC field-connected inductive load: i.e., relay coil, motor starter coil, etc. shall have a transient suppressor wired in parallel with its coil, physically located at the coil. Spare transient suppressors and control circuit fuse are supplied in a bad attached to the fuseholder.

MILLENNIUM CONTROL CENTER ELEMENTARY DIAGRAM (CONT'D.)

ELEMENTARY DIAGRAM

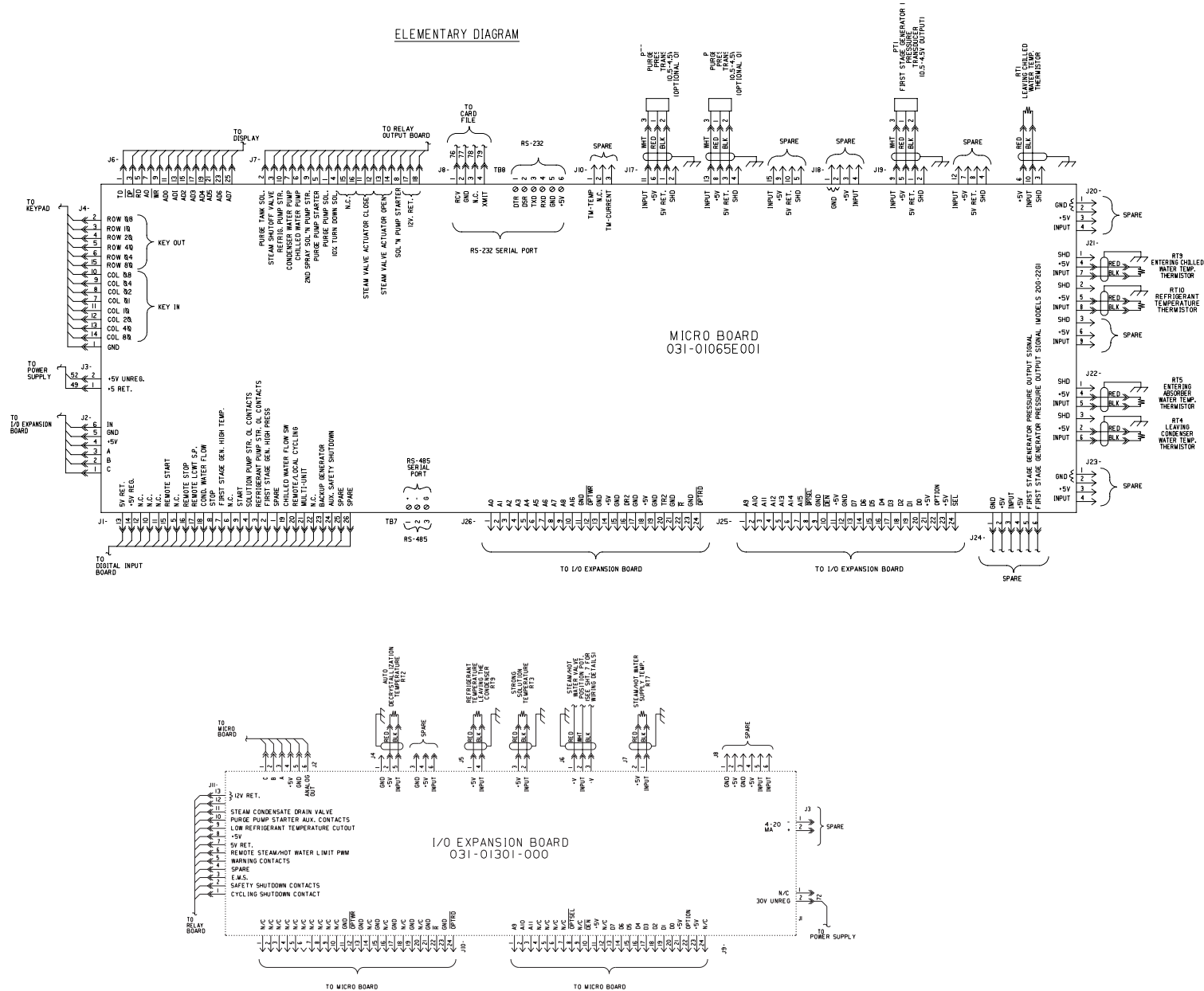

LD01215

MILLENNIUM CONTROL CENTER ELEMENTARY DIAGRAM (CONT'D.)

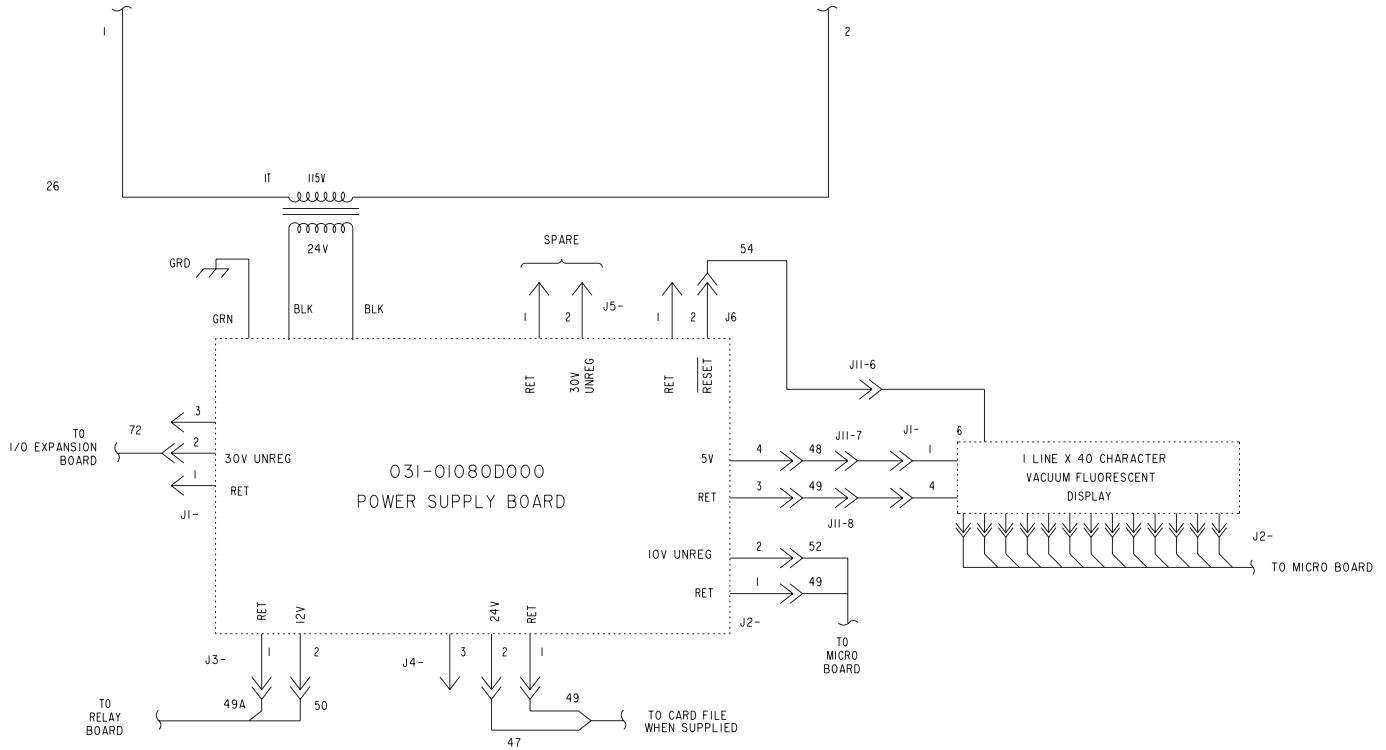

LD01212

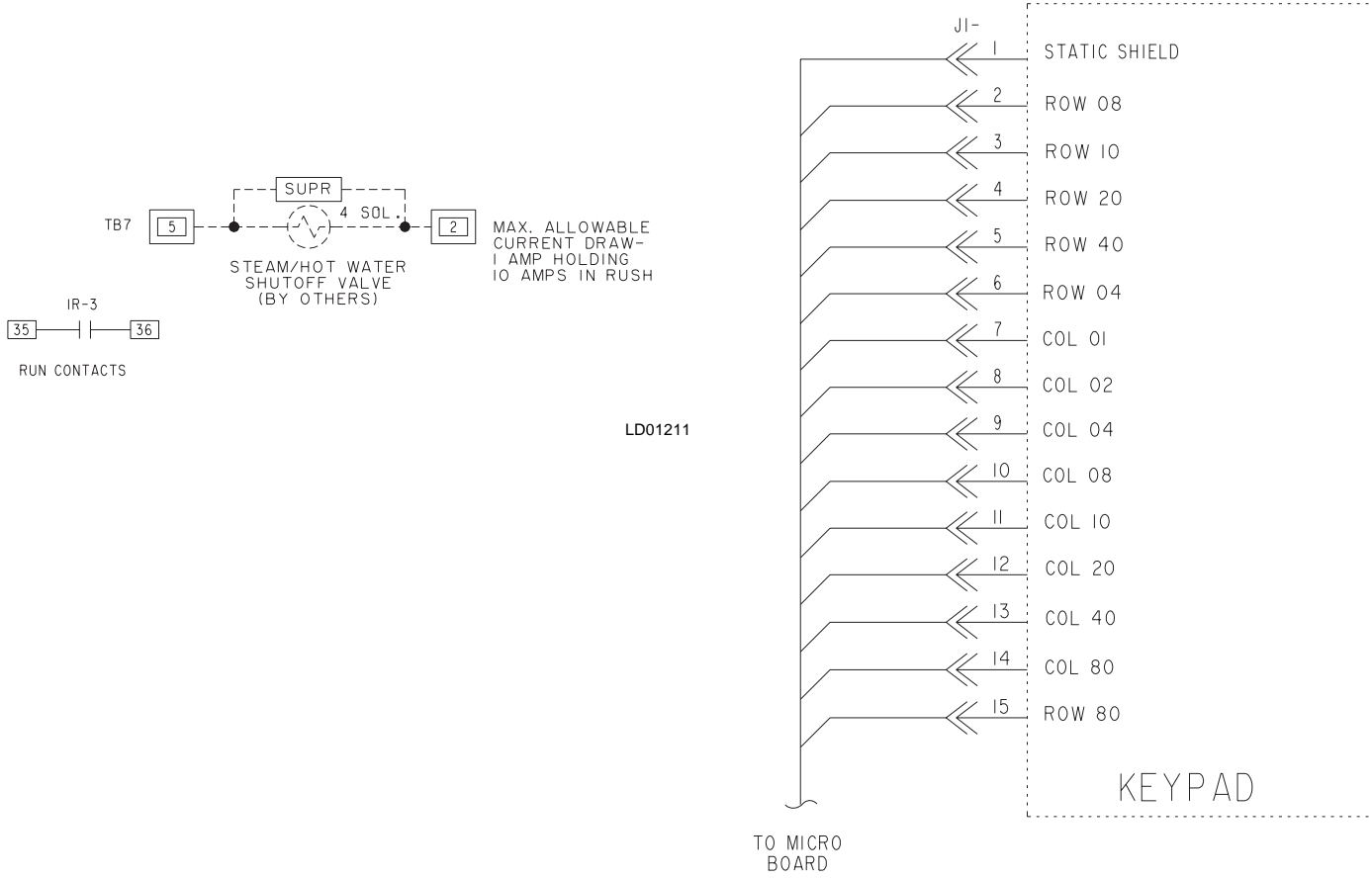

LD01211

LD01213

MILLENNIUM CONTROL CENTER CONNECTION DIAGRAM

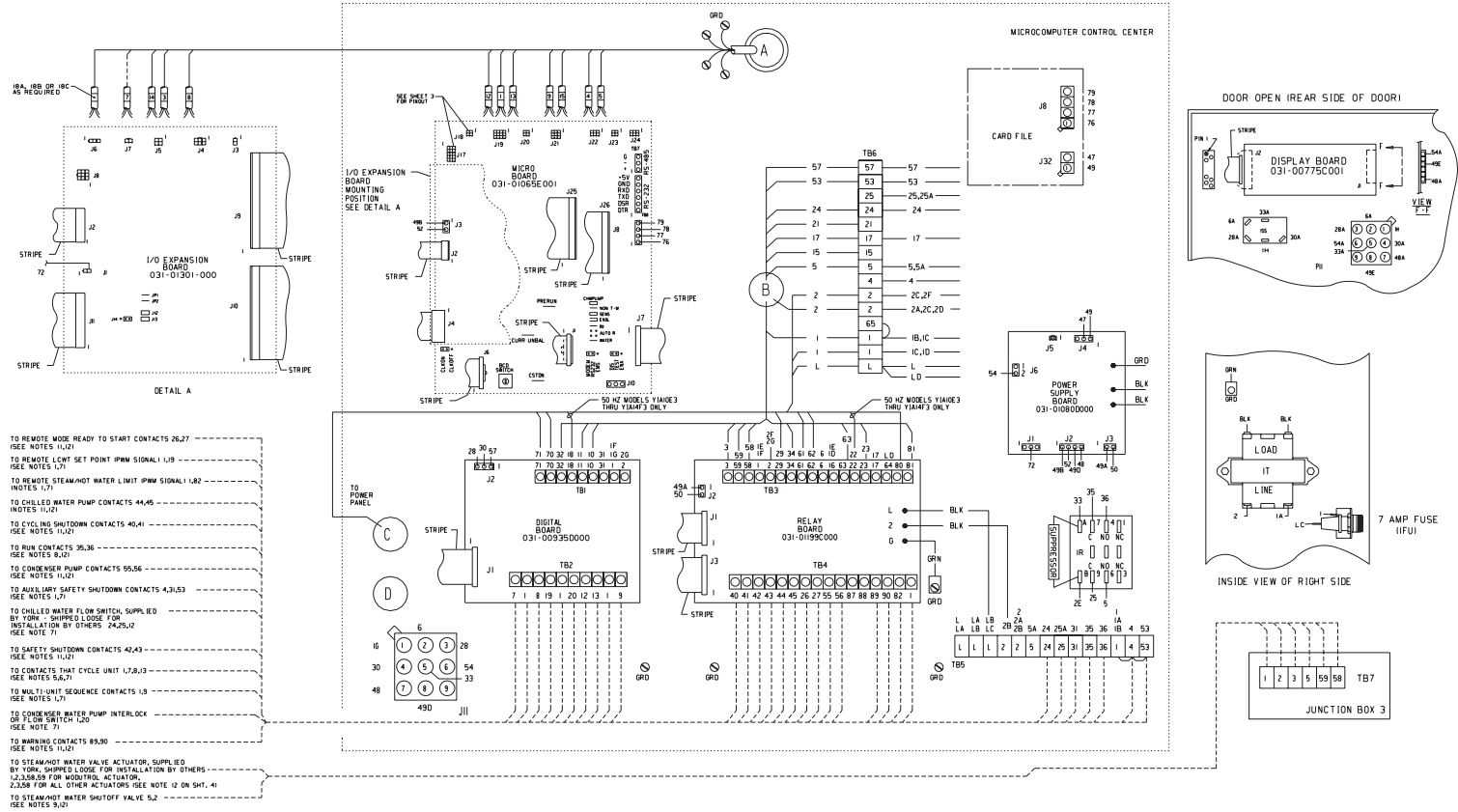

- TO REMOTE WIDE READY TO START CONTACTS 26,27
SEE NOTES 11,21
- TO REMOTE LOW SET POINT (PWR SIGNAL) 1,9
SEE NOTES 1,7
- TO REMOTE STEAM/HOT WATER LIMIT (PWR SIGNAL) 1,82
NOTES 1,7
- TO CHILLED WATER PUMP CONTACTS 44,45
NOTES 11,21
- TO RUN CONTACTS 35,36
SEE NOTES 8,21
- TO CONDENSER PUMP CONTACTS 55,56
SEE NOTES 11,21
- TO AUXILIARY SAFETY SHUTDOWN CONTACTS 4,31,33
SEE NOTES 1,7
- TO CHILLED WATER FLOW SWITCH, SUPPLIED
BY YORK - SHIPPED LOOSE FOR
INSTALLATION BY OTHERS 14,25,32
SEE NOTE 7
- TO SAFETY SHUTDOWN CONTACTS 42,43
SEE NOTES 11,21
- TO CONTACTS THAT CYCLE UNIT 1,7,8,13
SEE NOTES 5,6,7
- TO MULTI-UNIT SEQUENCE CONTACTS 1,9
SEE NOTES 1,7
- TO CONDENSER WATER PUMP INTERLOCK
OR FLOW SWITCH 4, 1,20
SEE NOTE 7
- TO WARNING CONTACTS 89,90
SEE NOTES 11,21
- TO STEAM/HOT WATER VALVE ACTUATOR, SUPPLIED
BY YORK, SHIPPED LOOSE FOR INSTALLATION BY OTHERS
12,23,26,59 FOR WARNING ACTUATOR,
2,3,38 FOR ALL OTHER ACTUATORS SEE NOTE 12 ON SHT. 41
TO STEAM/HOT WATER SHUTDOWN VALVE 5,2
SEE NOTES 3,21

LD01216

PRESSURE – TEMPERATURE CHART

PRESSURE - TEMP CHART							
APPLICATION		DEVICE	UNITS	OPERATING POINT			
STEAM FED CHILLER	HOT WATER FED CHILLER			ON RISE		ON FALL	
✓	✓	HPI	PSIA/KPa	CUT-OUT 13.73/94.67	HP OVER-RIDE-FORCED UNLOAD * 10.00/68.9	HP OVER-RIDE RELEASE * 6.00/41.4	CUT-IN 0.77/5.31
✓	✓	HTI	DEG.F/ DEG.C	CUT-OUT 330/165.6		CUT-IN MANUAL RESET 326/163.3	
✓	✓	LRT	DEG.F/ DEG.C	CUT-IN 38.0/3.3 □ 38.0/3.3 **	LRT OVER-RIDE-ALLOW LOADING 36.0/2.2 □	LRT OVER-RIDE INHIBIT LOADING 35.5/1.9 □	CUT-OUT 33.0/0.6 □ 33.0/0.6 **
✓	✓	LWT	DEG.F/ DEG.C	2.0/1.1 ABOVE THE CHILLED WATER TEMP. SETPOINT		2.0/1.1 BELOW THE CHILLED WATER TEMP. SETPOINT: WHEN THE SETPOINT IS RAISED, LWT= THE PREVIOUS VALUE FOR 30 MINUTES	
✓		HP2 ++	PSIA/KPa	CUT-OUT 29.0/199.9	HP2 STEAM SUPPLY WARNING 26.0/179.3	HP2 STEAM SUPPLY RELEASE 25.5/175.8	CUT-IN 28.9/199.3
	✓	HT +	DEG.F/ DEG.C	CUT-OUT 260/126.7	HOT WATER SUPPLY WARNING 250/121.1	HOT WATER SUPPLY RELEASE 249.5/120.8	CUT-IN 259.9/126.6
✓		HT +	DEG.F/ DEG.C	CUT-OUT 285/140.6	STEAM SUPPLY WARNING 280/137.8	STEAM SUPPLY RELEASE 279/137.2	CUT-IN 284/140
<p>* FUNCTION PROVIDED BY GENERATOR PRESSURE TRANSDUCER</p> <p>+ FUNCTION PROVIDED BY STEAM OR HOT WATER SUPPLY TEMP. SENSOR (RT7)</p> <p>□ FUNCTION PROVIDED BY REFRIGERANT TEMP. SENSOR (RT10)</p> <p>** FUNCTION PROVIDED BY REFRIGERANT TEMPERATURE SWITCH (LRT) (BACKUP)</p> <p>++ FUNCTION PROVIDED BY STEAM SUPPLY PRESSURE TRANSDUCER</p>							

LD01214

MILLENNIUM CONTROL CENTER CONNECTION DIAGRAM

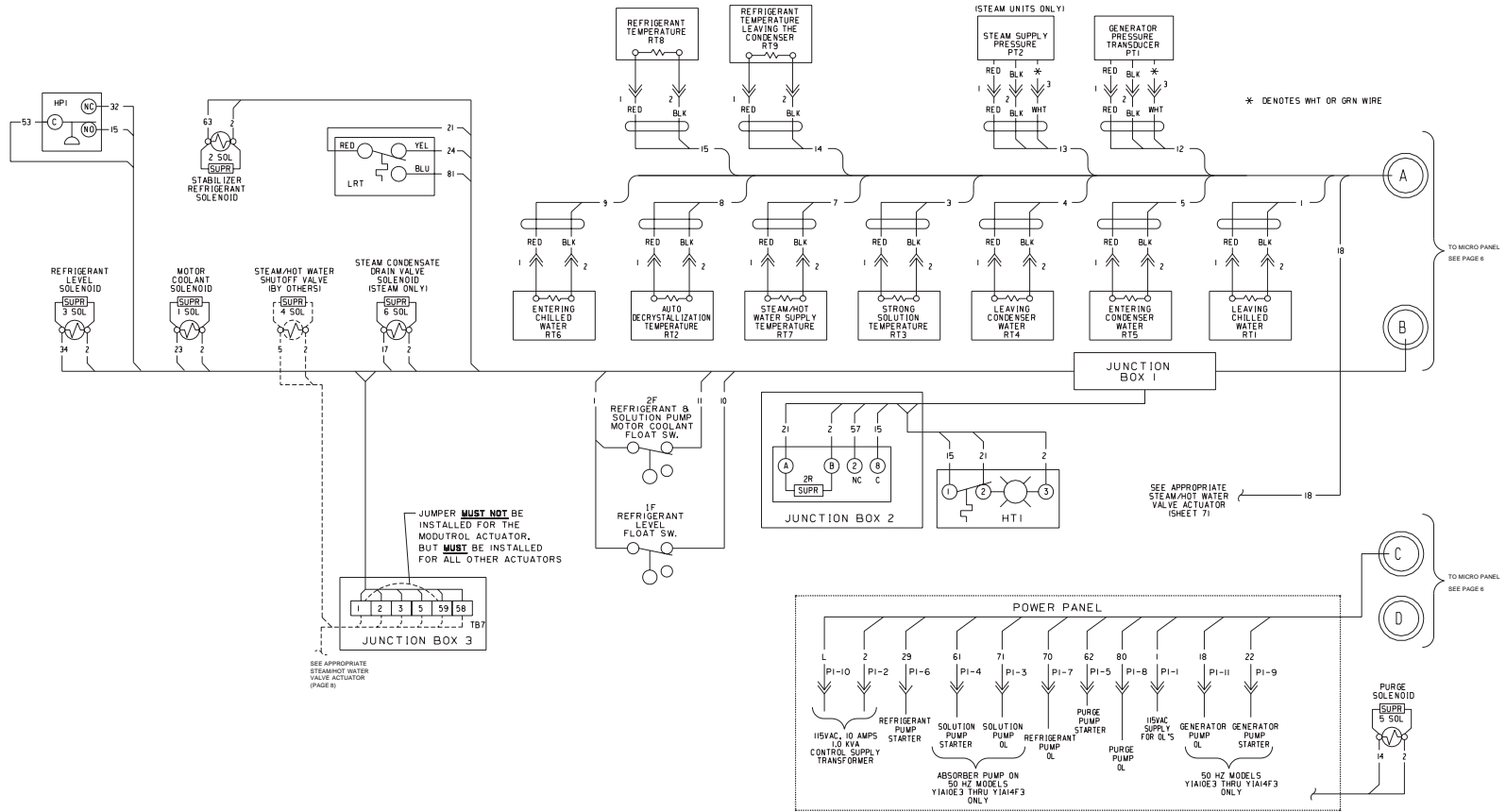

LD01217

POWER PANEL ELEMENTARY DIAGRAM

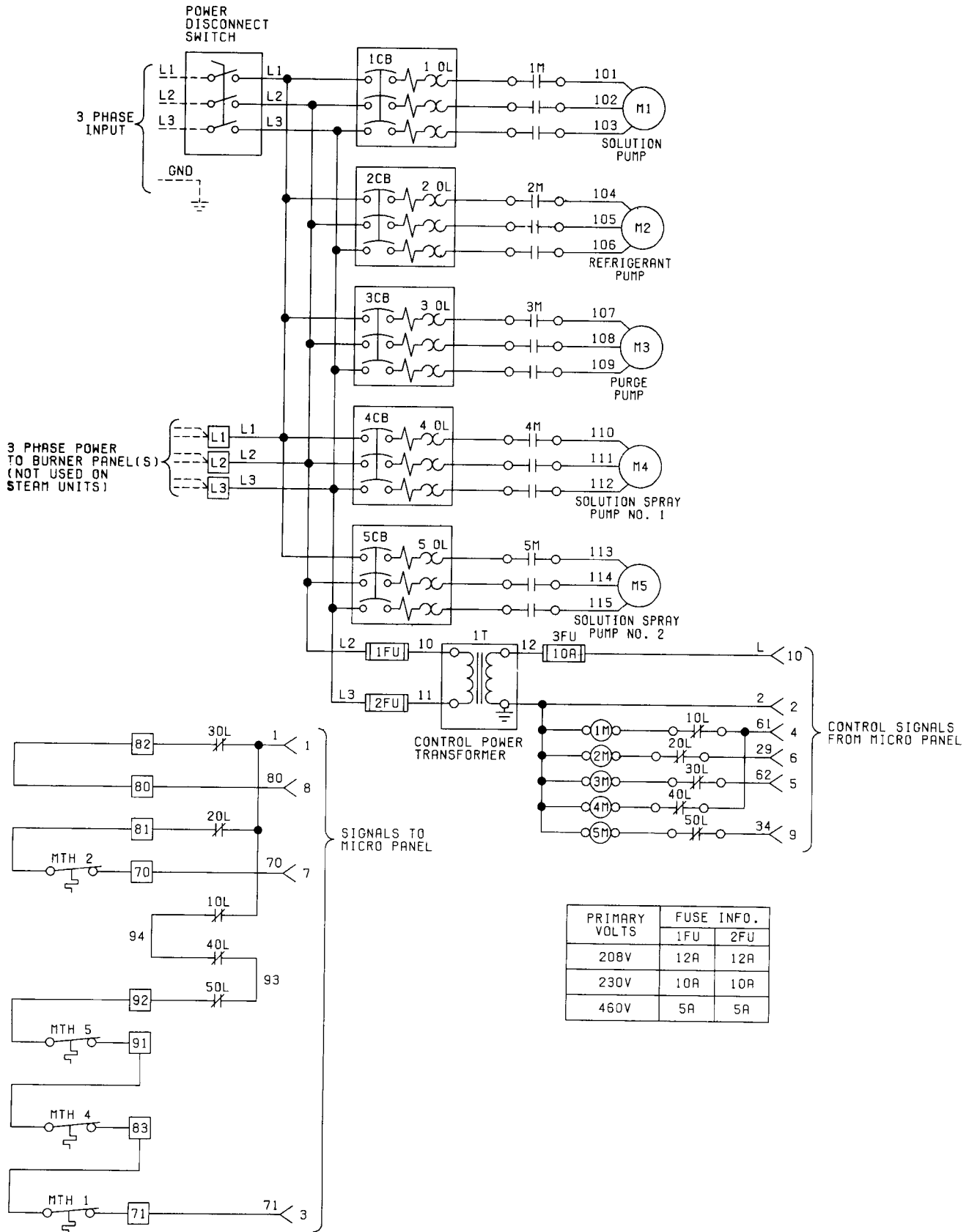

NOTE: This drawing represents the standard UL burner panel scope of supply. For project specific burner panel wiring details, please consult factory submitted information.

STEAM/HOT WATER VALVE ACTUATORS

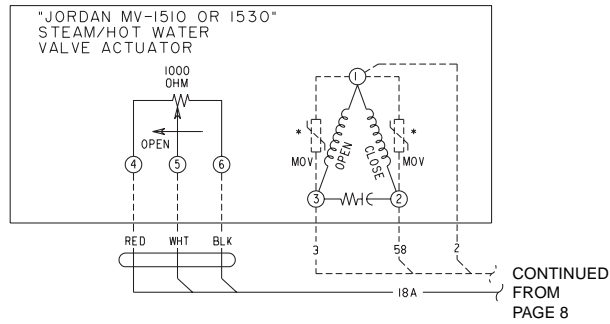

LD01221

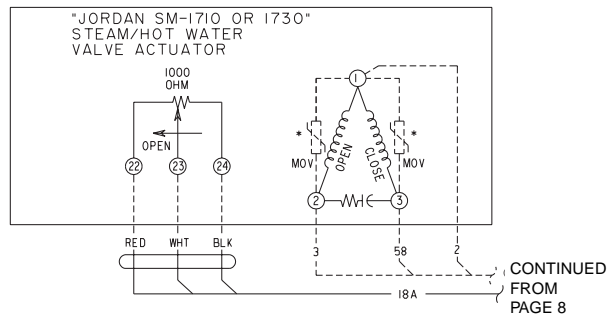

LD01219

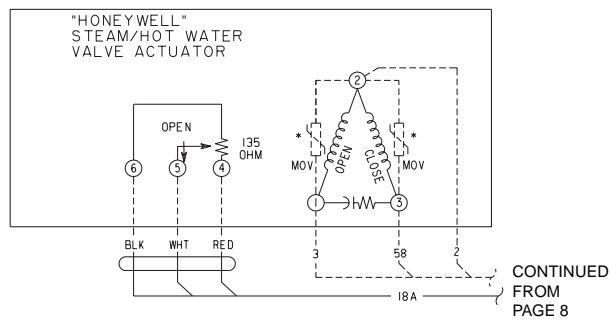

LD01220

* MOV'S ARE PROVIDED IN BAG SUPPLIED INSIDE MICRO PANEL. INSTALL AS SHOWN.

STEAM/HOT WATER VALVE ACTUATORS

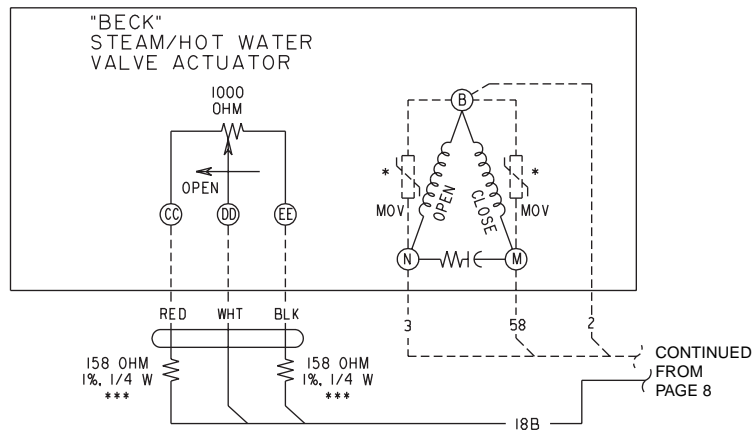

LD01218

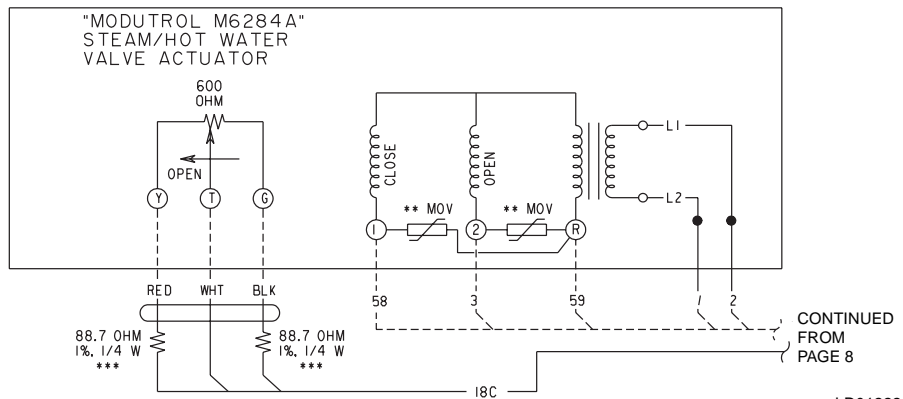

LD01222

- * MOV'S ARE PROVIDED IN BAG SUPPLIED INSIDE MICRO PANEL. INSTALL AS SHOWN.
- ** MOV'S ARE INSTALLED BY MODUTROL. INSTALLATION BY OTHERS IS NOT REQUIRED.
- *** RESISTORS ARE LOCATED IN CABLE AT MICRO PANEL END.



Proud Sponsor
of the 1998
U.S. Olympic Team

36USC380