



**OPTISPEED™ LIQUID COOLED
VARIABLE SPEED DRIVE
FOR CENTRIFUGAL CHILLERS**

SERVICE MANUAL

Supersedes: 160.00-M4 (516)

Form 160.00-M4 (1217)

MODELS VSD 270, 292, 351, 385, 419, 424, 503, 608, 658, 704
MODELS LVD 270, 292, 351, 385, 419, 424, 503, 608, 658, 704, 900



00633VIP

VSD MODELS

270 HP – 60 HZ, 400 VAC
292 HP – 50 HZ, 400 VAC
292 HP – 50 HZ, 415 VAC
351 HP – 60 HZ, 460 VAC
385 HP – 60 HZ, 400 VAC
419 HP – 50 HZ, 400 VAC
419 HP – 50 HZ, 415 VAC
424 HP – 60 HZ, 575 VAC
503 HP – 60 HZ, 460 VAC
608 HP – 60 HZ, 575 VAC
658 HP – 50 HZ, 400 VAC
704 HP – 50 HZ, 415 VAC

LVD MODELS

270 HP – 60 HZ, 380 VAC
270 HP – 60 HZ, 400 VAC
292 HP – 50 HZ, 400 VAC
292 HP – 50 HZ, 415 VAC
351 HP – 60 HZ, 460 VAC
385 HP – 60 HZ, 380 VAC
385 HP – 60 HZ, 400 VAC
419 HP – 50 HZ, 400 VAC
419 HP – 50 HZ, 415 VAC
424 HP – 60 HZ, 575 VAC
503 HP – 60HZ, 460 VAC
608 HP – 60HZ, 575 VAC
658 HP – 50 HZ, 400 VAC
704 HP – 50 HZ, 415 VAC
900 HP – 50 HZ, 400 VAC
900 HP – 50 HZ, 415 VAC

Issue Date:
December 19, 2017



IMPORTANT!

READ BEFORE PROCEEDING!

GENERAL SAFETY GUIDELINES

This equipment is a relatively complicated apparatus. During rigging, installation, operation, maintenance, or service, individuals may be exposed to certain components or conditions including, but not limited to: heavy objects, refrigerants, materials under pressure, rotating components, and both high and low voltage. Each of these items has the potential, if misused or handled improperly, to cause bodily injury or death. It is the obligation and responsibility of rigging, installation, and operating/service personnel to identify and recognize these inherent hazards, protect themselves, and proceed safely in completing their tasks. Failure to comply with any of these requirements could result in serious damage to the equipment and the property in

which it is situated, as well as severe personal injury or death to themselves and people at the site.

This document is intended for use by owner-authorized rigging, installation, and operating/service personnel. It is expected that these individuals possess independent training that will enable them to perform their assigned tasks properly and safely. It is essential that, prior to performing any task on this equipment, this individual shall have read and understood the on-product labels, this document and any referenced materials. This individual shall also be familiar with and comply with all applicable industry and governmental standards and regulations pertaining to the task in question.

SAFETY SYMBOLS

The following symbols are used in this document to alert the reader to specific situations:



Indicates a possible hazardous situation which will result in death or serious injury if proper care is not taken.



Identifies a hazard which could lead to damage to the machine, damage to other equipment and/or environmental pollution if proper care is not taken or instructions and are not followed.



Indicates a potentially hazardous situation which will result in possible injuries or damage to equipment if proper care is not taken.

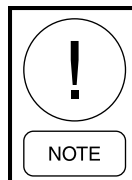

Highlights additional information useful to the technician in completing the work being performed properly.



External wiring, unless specified as an optional connection in the manufacturer's product line, is not to be connected inside the control cabinet. Devices such as relays, switches, transducers and controls and any external wiring must not be installed inside the micro panel. All wiring must be in accordance with Johnson Controls' published specifications and must be performed only by a qualified electrician. Johnson Controls will NOT be responsible for damage/problems resulting from improper connections to the controls or application of improper control signals. Failure to follow this warning will void the manufacturer's warranty and cause serious damage to property or personal injury.

CHANGEABILITY OF THIS DOCUMENT

In complying with Johnson Controls' policy for continuous product improvement, the information contained in this document is subject to change without notice. Johnson Controls makes no commitment to update or provide current information automatically to the manual or product owner. Updated manuals, if applicable, can be obtained by contacting the nearest Johnson Controls Service office or accessing the Johnson Controls QuickLIT website at <http://cgproducts.johnsoncontrols.com>.

It is the responsibility of rigging, lifting, and operating/service personnel to verify the applicability of these documents to the equipment. If there is any question

regarding the applicability of these documents, rigging, lifting, and operating/service personnel should verify whether the equipment has been modified and if current literature is available from the owner of the equipment prior to performing any work on the chiller.

CHANGE BARS

Revisions made to this document are indicated with a line along the left or right hand column in the area the revision was made. These revisions are to technical information and any other changes in spelling, grammar or formatting are not included.

ASSOCIATED LITERATURE

MANUAL DESCRIPTION	FORM NUMBER
Operation Manual (Unit) Model YT, (Centrifugal)	160.55-O1
Operation Manual (Unit) Model YK, (Centrifugal)	160.75-O1
Operation Manual (Control Panel) Model YT, (Centrifugal)	160.55-O1
Operation Manual (Control Panel) Model YK, (Centrifugal)	160.54-O1
Service Manual (Control Panel) Model YT, (Centrifugal)	160.55-M1
Service Manual (Control Panel) Model YK, (Centrifugal)	160.54-M1
Wiring Diagram (Control Panel) Model YT, (Centrifugal)	160.55-PW2
Wiring Diagram (Control Panel) Model YK, (Centrifugal)	160.78-PW8
Wiring Field Connections (Variable Speed Drive) Model YT, (Centrifugal)	160.48-PA15
Wiring Field Connections (Variable Speed Drive) Model YK, (Centrifugal)	160.54-PW6
Operation Manual (Control Panel) Model VSD (Compressor Speed Drive)	160.00-O4
Renewal Parts (Variable Speed Drive Global Version)	160.00-RP4
Renewal Parts (Variable Speed Drive Asia Version)	W160-RP4.EN



The Control/VSD Cabinet contains lethal High AC and DC voltages. Before performing service inside the cabinet, remove the AC supply feeding the chiller and verify using a non-contact voltage sensor. The DC Voltage on the VSD DC Bus will take 5 minutes to bleed off, after AC power is removed. Always check the DC Bus Voltage with a Voltmeter to assure the capacitor charge has bled off before working on the system.

- ***NEVER short out the DC Bus to discharge the filter capacitors.***
- ***NEVER place loose tools, debris, or any objects inside the Control Panel/VSD Cabinet.***
- ***NEVER allow the Control Panel VSD Cabinet doors to remain open if there is a potential for rain to enter the panel. Keep doors closed and assure all latches are engaged on each door unless the unit is being serviced.***
- ***ALWAYS lockout the disconnect supplying AC to the chiller.***
- ***The 1L Line Inductor will reach operating temperatures of over 300° F. DO NOT open panel doors during operation. Assure the inductor is cool whenever working near the inductor with power off.***

NOMENCLATURE

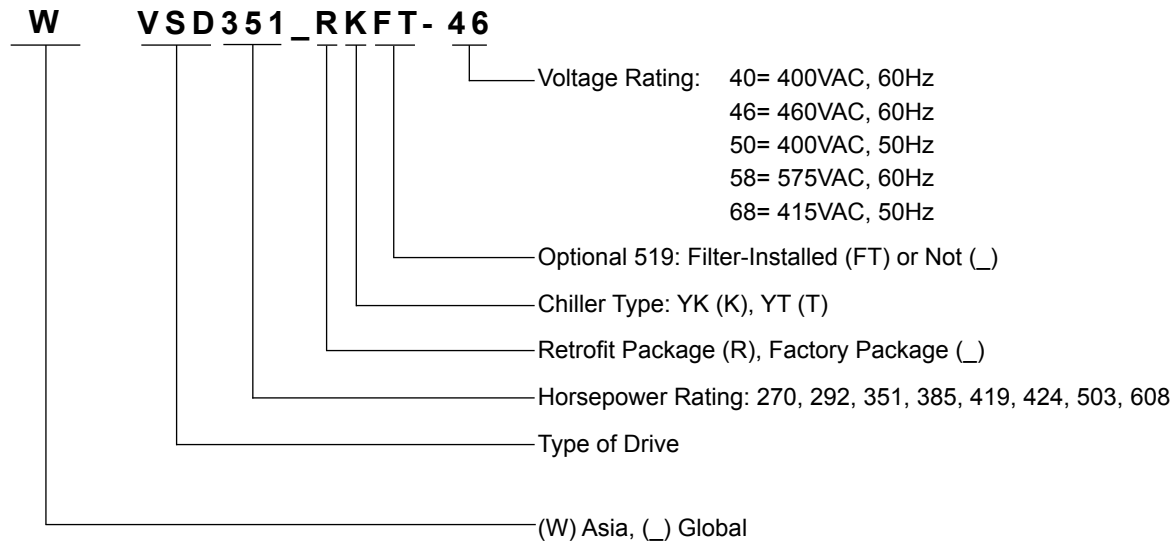

OPTISPEED™ MODEL PART NUMBERS

The X in the part number below indicates which type of communications is used between the Micropanel and the OSCD: 1 = YORK Protocol, 7 = MODBUS Protocol, 8 = MODBUS with CPC, W = Asia (W in the 4th position, taking the place of the first hyphen in the part number)

TABLE 1 - VSD PART NUMBERS AND DESCRIPTIONS

MODEL	PART NUMBER		DESCRIPTION	
	60 HZ	50 HZ		
270 HP 400 VAC	VSD270T-40	371-02767-X21	Factory Pack, YT Base Model	
	VSD270K-40	371-02767-X22	Factory Pack, YK Base Model	
	VSD270TFT-40	371-02767-X25	Factory Pack, YT Filter Model	
	VSD270KFT-40	371-02767-X26	Factory Pack, YK Filter Model	
	VSD270RT-40	371-02767-X31	Retrofit, YT Base Model	
	VSD270RK-40	371-02767-X32	Retrofit, YK Base Model	
	VSD270RTFT-40	371-02767-X35	Retrofit, YT Filter Model	
	VSD270RKFT-40	371-02767-X36	Retrofit, YK Filter Model	
292 HP 400 VAC	VSD292T-50		371-03700-X01	Factory Pack, YT Base Model
	VSD292K-50		371-03700-X02	Factory Pack, YK Base Model
	VSD292TFT-50		371-03700-X05	Factory Pack, YT Filter Model
	VSD292KFT-50		371-03700-X06	Factory Pack, YK Filter Model
	VSD292RT-50		371-03700-X11	Retrofit, YT Base Model
	VSD292RK-50		371-03700-X12	Retrofit, YK Base Model
	VSD292RTFT-50		371-03700-X15	Retrofit, YT Filter Model
	VSD292RKFT-50		371-03700-X16	Retrofit, YK Filter Model
	W-VSD292K-50		371W06040-X02	Factory Pack, YK Base Model
	W-VSD292KFT-50		371W06040-X06	Factory Pack, YK Filter Model

TABLE 1 - VSD PART NUMBERS AND DESCRIPTIONS (CONT'D)

MODEL		PART NUMBER		DESCRIPTION
		60 HZ	50 HZ	
292 HP 415 VAC	VSD292T-68		371-03700-X21	Factory Pack, YT Base Model
	VSD292K-68		371-03700-X22	Factory Pack, YK Base Model
	VSD292TFT-68		371-03700-X25	Factory Pack, YT Filter Model
	VSD292KFT-68		371-03700-X26	Factory Pack, YK Filter Model
	VSD292RT-68		371-03700-X31	Retrofit, YT Base Model
	VSD292RK-68		371-03700-X32	Retrofit, YK Base Model
	VSD292RTFT-68		371-03700-X35	Retrofit, YT Filter Model
	VSD292RKFT-68		371-03700-X36	Retrofit, YK Filter Model
	W-VSD292K-68		371W06040-X22	Factory Pack, YK Base Model
	W-VSD292KFT-68		371W06040-X26	Factory Pack, YK Filter Model
351 HP 460 VAC	VSD351T-46	371-02767-X01		Factory Pack, YT Base Model
	VSD351K-46	371-02767-X02		Factory Pack, YK Base Model
	VSD351TFT-46	371-02767-X05		Factory Pack, YT Filter Model
	VSD351TFK-46	371-02767-X06		Factory Pack, YK Filter Model
	VSD351RT-46	371-02767-X11		Retrofit, YT Base Model
	VSD351RK-46	371-02767-X12		Retrofit, YK Base Model
	VSD351RTFT-46	371-02767-X15		Retrofit, YT Filter Model
	VSD351RTFK-46	371-02767-X16		Retrofit, YK Filter Model
385 HP 400 VAC	VSD385T-40	371-03789-X21		Factory Pack, YT Base Model
	VSD385K-40	371-03789-X22		Factory Pack, YK Base Model
	VSD385TFT-40	371-03789-X23		Factory Pack, YT Filter Model
	VSD385KFT-40	371-03789-X24		Factory Pack, YK Filter Model
	VSD385RT-40	371-03789-X31		Retrofit, YT Base Model
	VSD385RK-40	371-03789-X32		Retrofit, YK Base Model
	VSD385RTFT-40	371-03789-X33		Retrofit, YT Filter Model
	VSD385RKFT-40	371-03789-X34		Retrofit, YK Filter Model
419 HP 400 VAC	VSD419T-50		371-03789-X05	Factory Pack, YT Base Model
	VSD419K-50		371-03789-X06	Factory Pack, YK Base Model
	VSD419TFT-50		371-03789-X07	Factory Pack, YT Filter Model
	VSD419KFT-50		371-03789-X08	Factory Pack, YK Filter Model
	VSD419RT-50		371-03789-X15	Retrofit, YT Base Model
	VSD419RK-50		371-03789-X16	Retrofit, YK Base Model
	VSD419RTFT-50		371-03789-X17	Retrofit, YT Filter Model
	VSD419RKFT-50		371-03789-X18	Retrofit, YK Filter Model
	W-VSD419K-50		371W06431-X06	Factory Pack, YK Base Model
	W-VSD419KFT-50		371W06431-X08	Factory Pack, YK Filter Model
	W-VSD419T-50		371-05395-X05	Factory Pack, YT Base Model
	W-VSD419K-50		371-05395-X06	Factory Pack, YK Base Model
	W-VSD419TFT-50		371-05395-X07	Factory Pack, YT Filter Model
	W-VSD419KFT-50		371-05395-X08	Factory Pack, YK Filter Model
	W-VSD419RT-50		371-05395-X15	Retrofit, YT Base Model
	W-VSD419RK-50		371-05395-X16	Retrofit, YK Base Model
	W-VSD419RTFT-50		371-05395-X17	Retrofit, YT Filter Model
W-VSD419RKFT-50		371-05395-X18	Retrofit, YK Filter Model	

TABLE 1 - VSD PART NUMBERS AND DESCRIPTIONS (CONT'D)

MODEL		PART NUMBER		DESCRIPTION
		60 HZ	50 HZ	
419 HP 415 VAC	VSD419T-68		371-03789-X25	Factory Pack, YT Base Model
	VSD419K-68		371-03789-X26	Factory Pack, YK Base Model
	VSD419TFT-68		371-03789-X27	Factory Pack, YT Filter Model
	VSD419KFT-68		371-03789-X28	Factory Pack, YK Filter Model
	VSD419RT-68		371-03789-X35	Retrofit, YT Base Model
	VSD419RK-68		371-03789-X36	Retrofit, YK Base Model
	VSD419RTFT-68		371-03789-X37	Retrofit, YT Filter Model
	VSD419RKFT-68		371-03789-X38	Retrofit, YK Filter Model
	W-VSD419K-68		371W06431-X26	Factory Pack, YK Base Model
	W-VSD419KFT-68		371W06431-X28	Factory Pack, YK Filter Model
424 HP 575 VAC	VSD424T-58	371-04881-X01		Factory Pack, YT Base Model
	VSD424K-58	371-04881-X02		Factory Pack, YK Base Model
	VSD424TFT-58	371-04881-X03		Factory Pack, YT Filter Model
	VSD424TFK-58	371-04881-X04		Factory Pack, YK Filter Model
	VSD424RT-58	371-04881-X11		Retrofit, YT Base Model
	VSD424RK-58	371-04881-X12		Retrofit, YK Base Model
	VSD424RTFT-58	371-04881-X13		Retrofit, YT Filter Model
	VSD424RTFK-58	371-04881-X14		Retrofit, YK Filter Model
503 HP 460 VAC	VSD503T-46	371-03789-X01		Factory Pack, YT Base Model
	VSD503K-46	371-03789-X02		Factory Pack, YK Base Model
	VSD503TFT-46	371-03789-X03		Factory Pack, YT Filter Model
	VSD503TFK-46	371-03789-X04		Factory Pack, YK Filter Model
	VSD503RT-46	371-03789-X11		Retrofit, YT Base Model
	VSD503RK-46	371-03789-X12		Retrofit, YK Base Model
	VSD503RTFT-46	371-03789-X13		Retrofit, YT Filter Model
	VSD503RTFK-46	371-03789-X14		Retrofit, YK Filter Model
608 HP 575 VAC	VSD424T-58	371-04563-X01		Factory Pack, YT Base Model
	VSD424K-58	371-04563-X02		Factory Pack, YK Base Model
	VSD424TFT-58	371-04563-X03		Factory Pack, YT Filter Model
	VSD424TFK-58	371-04563-X04		Factory Pack, YK Filter Model
	VSD424RT-58	371-04563-X11		Retrofit, YT Base Model
	VSD424RK-58	371-04563-X12		Retrofit, YK Base Model
	VSD424RTFT-58	371-04563-X13		Retrofit, YT Filter Model
	VSD424RTFK-58	371-04563-X14		Retrofit, YK Filter Model
658 HP 400 VAC	W-VSD658K-50		371W06212-X02	Factory Pack, YK Base Model
	W-VSD658KFT-50		371W06212-X04	Factory Pack, YK Filter Model
704 HP 415 VAC	W-VSD704K-68		371W06212-X22	Factory Pack, YK Base Model
	W-VSD704KFT-68		371W06212-X24	Factory Pack, YK Filter Model

NOMENCLATURE

LVD 0503 G R N01 K C 30 B 06 L Z - 46 A

I II III IV V VI VII VIII IX X XI XII XIII XIV

I - Drive Type

LVD
(historical models)
VSD
TM
HYP

II - Horsepower and Amp Rating

(4 digits fixed length)

III - Design Center/Source

G = Global Design
W = Asia Design
T = Toshiba
B = Benshaw

IV - VSD Mounting Method

X = Unit Mount (Factory Pack)
R = Remote Mount (Floor Standing)

V - Enclosure Type Rating

N01 = NEMA 1
N04 = NEMA4
N3R = NEMA 3R
I33 = IP33
*** = Not yet defined

VI - Chiller Type

H = YMC2 (YH)
K = YK
T = YT

VII - Chiller Cooling Method/VSD Cooling Medium

C = Condenser liquid cooled / water
E = Evaporator liquid cooled / water
D = Condenser liquid cooled / glycol
F = Evaporator liquid cooled / glycol
B = Air cooled / glycol
A = Air cooled / air
R = Refrigerant / refrigerant
* = Not yet defined

VIII - Liquid DWP

15 = 150 PSIG
30 = 300 PSIG
* = Not yet defined

IX - Input Connection

D = Disconnect Switch
B = Circuit Breaker
T = Terminal Block
* = Not yet defined

X - Input Connection Rating

04 = 400A
06 = 600A
08 = 800A
10 = 1000A
12 = 1200A
00 = None (terminal block)
* = Not yet defined

XI - Code Agency Approval

L = cUL/cETL
C = CE
G = GB
Q = Special
X = None

XII - Harmonic Mitigation

F = Filter Model
Z = Base Model
A = Active Front End Model

XIII - Input Voltage/Frequency (Per M-527)

40 = 380/400V 60Hz
50 = 380/400V 50Hz
42 = 400V 60Hz
46 = 460V 60Hz
68 = 415V 50Hz
58 = 575V 60Hz

XIV - Product Mod Level Suffix

A = Mod Level "A"
B = Mod Level "B"

OPTISPEED™ MODEL PART NUMBERS (CONT'D)

The X in the part number below indicates which type of communications is used between the Micropanel and the OSCD: 1 = YORK Protocol, 7 = MODBUS Protocol, 8 = MODBUS w/ CPC, W = Asia (4th position taking place of the first hyphen in the part number)

TABLE 2 - LVD PART NUMBERS AND DESCRIPTIONS

MODEL NUMBER		PART NUMBER	DESCRIPTION
270 HP – 60 HZ, 380 – 400 VAC	LVD0270GXN01KC30B04LZ-40A	371-06976-X22	Factory Pack, YK Chiller
270 HP – 60 HZ, 400 VAC	LVD0270GXN01KC30B04LZ-42A	371-06976-X46	Factory Pack, YK Chiller (Saudi)
292 HP – 50 HZ, 400 VAC	LVD0292WXI22KC30B04GZ-50A	371W06640-X02	Factory Pack, YK Chiller
292 HP – 50 HZ, 380 – 400 VAC	LVD0292GXN01KC30B04LZ-50A	371-06976-X06	Factory Pack, YK Chiller
292 HP – 50 HZ, 415 VAC	LVD0292WXI22KC30B04GZ-68A	371W06640-X22	Factory Pack, YK Chiller
292 HP – 50 HZ, 415 VAC	LVD0292GXN01KC30B04LZ-68A	371-06976-X26	Factory Pack, YK Chiller
351 HP – 60 HZ, 460 VAC	LVD0315GXN01KC30B04LZ-46A	371-06976-X02	Factory Pack, YK Chiller
385 HP – 60 HZ, 380 – 400 VAC	LVD0385GXN01KC30B06LZ-40A	371-06697-X22	Factory Pack, YK Chiller
385 HP – 60 HZ, 400 VAC	LVD0385GXN01KC30B06LZ-42A	371-06697-X46	Factory Pack, YK Chiller
419 HP – 50 HZ, 380 – 400 VAC	LVD0419GXN01KC30B06LZ-50A	371-06697-X06	Factory Pack, YK Chiller
419 HP – 50 HZ, 400 VAC	LVD0419WXI22KC30B06GZ-50A	371W06642-X06	Factory Pack, YK Chiller
419 HP – 50 HZ, 415 VAC	LVD0419WXI22KC30B06GZ-68A	371W06642-X26	Factory Pack, YK Chiller
419 HP – 50 HZ, 415 VAC	LVD0419GXN01KC30B06LZ-68A	371-06697-X26	Factory Pack, YK Chiller
424 HP – 60 HZ, 575 VAC	LVD0424GXN01KC30B04LZ-58A	371-06976-X42	Factory Pack, YK Chiller
503 HP – 60 HZ, 460 VAC	LVD0503GXN01KC30B06LZ-46A	371-06697-X02	Factory Pack, YK Chiller
608 HP – 60 HZ, 575 VAC	LVD0608GXN01KC30B06LZ-58A	371-06697-X42	Factory Pack, YK Chiller
658 HP – 50 HZ, 400 VAC	LVD0658WXI22KC30B10GZ-50A	371W06644-X02	Factory Pack, YK Chiller
704 HP – 50 HZ, 415 VAC	LVD0704WXI22KC30B10GZ-68A	371W06644-X22	Factory Pack, YK Chiller
900 HP – 50 HZ, 400 VAC	LVD0900WXI22KC30B12GZ-50A	371W06646-X02	Factory Pack, YK Chiller
900 HP – 50 HZ, 415 VAC	LVD0900WXI22KC30B12GZ-68A	371W06646-X22	Factory Pack, YK Chiller

TABLE OF CONTENTS

SECTION 1 - OPTISPEED DRIVE COMPONENT OVERVIEW	13
OptiSpeed Compressor Drive 270, 292, 351 and 424 Hp.....	13
OptiSpeed Compressor Drive 385, 419, 503, 608, 658, 704, and 900 HP	14
575 VAC Drive Differences.....	14
Differences for the VSD and LVD model numbers:	14
Differences for the VSD and LVD model drives:.....	15
VSD Logic Board History.....	15
 SECTION 2 - HARMONIC FILTER OPTION	 43
General.....	43
Harmonic Filter Option 270, 292, 351 and 424 Hp.....	43
Harmonic Filter Logic Board History.....	46
Harmonic Filter Wiring Diagrams	48
Harmonic Filter Option 385, 419, 503 and 608 HP	56
575 VAC Harmonic Filter Differences From 460 VAC Harmonic Filter.....	56
 SECTION 3 - LVD MODEL WIRING DIAGRAMS	 63
 SECTION 4 - OPTISPEED COMPRESSOR DRIVE CONTROL SYSTEM OVERVIEW	 99
The Control Center.....	99
OptiSpeed Drive Logic Control Board	100
OptiSpeed Harmonic Filter Logic Control Board	101
Microcomputer Control Panel VSD Related Keypad Functions	101
OptiView Control Panel VSD Functions	102
 SECTION 5 - VSD ADAPTIVE CAPACITY CONTROL.....	 103
Setpoint Requirements.....	103
Stability Requirements	103
Full Open Vane Operation.....	103
Effects of Surge.....	103
Drive Not Slowing Down.....	104
Drive Does Not Respond To Chiller Surging	104
Stability Limit Adjustment	104
Surge Margin Adjustment.....	105
Software Version Changes.....	105
 SECTION 6 - SHUTDOWN MESSAGES.....	 107
SAFETY SHUTDOWNS.....	107
General Information.....	107
Motor or Starter - Current Imbalance	107
VSD - 105 % Motor Current Overload.....	108
VSD - High Converter Heatsink Temperature	108
VSD - High Inverter Baseplate Temperature (270, 292, 351, and 424 Hp drive only).....	108
VSD - High Phase (X) Inverter Baseplate Temperature	108
VSD - Precharge Lockout.....	109
Harmonic Filter - High Baseplate Temperature	109
Harmonic Filter - High Total Demand Distortion.....	109

TABLE OF CONTENTS (CONT'D)

CYCLING SHUTDOWNS	110
General Information.....	110
VSD - DC Bus Voltage Imbalance.....	110
VSD - High DC Bus Voltage.....	110
VSD - High Internal Ambient Temperature	111
VSD - High Phase A (or B, C) Instantaneous Current.....	111
VSD - Initialization Failed	112
VSD - Invalid Current Scale Selection.....	112
VSD - Logic Board Power Supply	112
VSD - Logic Board Processor	113
VSD - Low Converter Heatsink Temperature	113
VSD - Low DC Bus Voltage.....	114
VSD - Low Inverter Baseplate Temperature.....	114
VSD - Phase A (B, C) Gate Driver.....	114
VSD - Precharge - DC Bus Voltage Imbalance.....	115
VSD - Precharge - Low DC Bus Voltage.....	115
VSD - Run Signal	115
VSD - Serial Communications.....	116
VSD - Single Phase Input Power	117
VSD - Stop Contacts Open	117
Harmonic Filter - 110 % Input Current Overload	117
Harmonic Filter - DC Bus Voltage Imbalance.....	117
Harmonic Filter - DC Current Transformer 1(or 2).....	118
Harmonic Filter - High DC Bus Voltage.....	119
Harmonic Filter - High Phase A (B, C) Current.....	119
Harmonic Filter - Logic Board Or Communications.....	119
Harmonic Filter - Logic Board Power Supply	120
Harmonic Filter - Low DC Bus Voltage.....	120
Harmonic Filter - Phase Locked Loop.....	120
Harmonic Filter - Precharge - Low DC Bus Voltage.....	121
Harmonic Filter - Run Signal	121
WARNING MESSAGES	121
General Information.....	121
Warning - Vanes Uncalibrated - Fixed Speed	121
Warning - Harmonic Filter - Operation Inhibited.....	122
SECTION 7 - START-UP PREPARATIONS.....	123
Circuit Breaker Setup	123
OptiView Control Center.....	125
Micro Computer Control Center	126
SECTION 8 - TROUBLESHOOTING AND COMPONENT REPLACEMENT PROCEDURES.....	129
General Information.....	129
Verify Failure of the OSCD Power Module 270/292/351/424 Hp Drive.....	129
Verify Failure of the OSCD Power Module 385/419/503/608/658/704/900 Hp Drive.....	133
Verify Failure of the Harmonic Filter Module 270/292/351/424 and 385/419/503/608/658/704 Hp Drive 136 Replacement of the OSCD Power Module	136
Replacement of the Harmonic Filter Power Module.....	138
VSD Frequently Asked Questions	139
Temperature	147

LIST OF FIGURES

FIGURE 1 - VSD Model Drive Logic Board 031-02077-000, 031-02077-001	15
FIGURE 2 - VSD model drive logic board 031-02506-002, 031-02506-003	16
FIGURE 3 - VSD model drive logic board 031-02506-002, 031-02506-003 revision 'F' or later	16
FIGURE 4 - Elementary Wiring Diagram 270, 292 And 351 HP for VSD Models Global Design Manufactured After December 2006	18
FIGURE 5 - Elementary Wiring Diagram 270, 292 And 351 HP for VSD Models Global Design Manufactured Before December 2006	20
FIGURE 6 - Elementary Wiring Diagram 424 HP for VSD Models Global Design Manufactured After December 2006	22
FIGURE 7 - Elementary Wiring Diagram 424 HP for VSD Models Global Design Manufactured Before December 2006	24
FIGURE 8 - Elementary Wiring Diagram 385/419/503 HP for VSD Models Global Design Manufactured After December 2006	26
FIGURE 9 - Elementary Wiring Diagram 385/419/503 HP for VSD Models Global Design Manufactured Before December 2006	28
FIGURE 10 - Elementary Wiring Diagram 608 HP for VSD Models Global Design Manufactured After December 2006	30
FIGURE 11 - Elementary Wiring Diagram 608 HP for VSD Models Global Design Manufactured Before December 2006	32
FIGURE 12 - Power Assembly Elementary Wiring Diagram 385/419/503 HP for VSD Models Global Design	34
FIGURE 13 - Power Assembly Elementary Wiring Diagram 608 HP for VSD Models Global Design	34
FIGURE 14 - Transformer Wiring Asia Design	36
FIGURE 15 - Elementary Wiring Diagram 658 and 704 HP for VSD Models Asia Design	38
FIGURE 16 - Power Assembly Elementary Wiring Diagram 658 And 704 HP for VSD Models Asia Design	40
FIGURE 17 - VSD Input Current Without Filter	45
FIGURE 18 - VSD Input Current With Filter	45
FIGURE 19 - VSD model Harmonic Filter logic board 031-02932-XXX	46
FIGURE 20 - Harmonic Filter Elementary Wiring Diagram 270, 292 And 351 HP for VSD Models Global Design Manufactured After December 2006	48
FIGURE 21 - Harmonic Filter Elementary Wiring Diagram 270, 292 And 351 HP for VSD Models Global Design Manufactured Before December 2006	50
FIGURE 22 - Harmonic Filter Elementary Wiring Diagram 424 HP for VSD Models Global Design Manufactured After December 2006	52
FIGURE 23 - Harmonic Filter Elementary Wiring Diagram 424 HP for VSD Models Global Design Manufactured Before December 2006	54
FIGURE 24 - Harmonic Filter Wiring Diagram 385, 419 And 503 HP for VSD Models Global Design After December 2006	58
FIGURE 25 - Harmonic Filter Wiring Diagram 385, 419 And 503 HP for VSD Models Global Design Before December 2006	58
FIGURE 26 - Harmonic Filter Wiring Diagram 608 HP for VSD Models Global Design After December 2006	60
FIGURE 27 - Harmonic Filter Wiring Diagram 608 HP for VSD Models Global Design Before December 2006	60
FIGURE 28 - Elementary Wiring Diagram 270/292/351 HP for LVD Models Global Design	64
FIGURE 29 - Power assembly elementary Wiring Diagram 270/292/351 HP for LVD Models Global design	66
FIGURE 30 - Connection Diagram 270/292/351 HP for LVD Models Global Design	68
FIGURE 31 - Elementary Wiring Diagram 385/419/503 HP for LVD Models Global Design	70
FIGURE 32 - Power Assembly Elementary Wiring Diagram 385/419/503 HP for LVD Models Global Design	72
FIGURE 33 - Elementary Wiring Diagram 424 HP for LVD Models Global Design	74

LIST OF FIGURES (CONT'D)

FIGURE 34 - Power assembly elementary Wiring Diagram 424 HP for LVD Models Global Design	76
FIGURE 35 - Connection Wiring Diagram 424 HP for LVD Models Global Design.....	78
FIGURE 36 - Elementary Wiring Diagram 608 Hp for LVD Models Global Design	80
FIGURE 37 - Power Assembly Elementary Wiring Diagram 608 HP for LVD Models Global Design.....	82
FIGURE 38 - Elementary Wiring Diagram 292 HP for LVD Models Asia Design	84
FIGURE 39 - Elementary Wiring Diagram (400V and 415V 419HP 50Hz) for LVD Models Asia Design	86
FIGURE 40 - Power Assembly Elementary Wiring Diagram (400V and 415V 419HP 50Hz) for Lvd Models Asia Design	88
FIGURE 41 - Elementary Wiring Diagram 400V 658Hp And 415V 704HP 50Hz) for LVD Models Asia Design	90
FIGURE 42 - Power Assembly Elementary Wiring Diagram (400V 658HP And 415V 704HP 50Hz) for LVD Models Asia Design	92
FIGURE 43 - Elementary Wiring Diagram 900 HP For LVD Models Asia Design	94
FIGURE 44 - Power Assembly Elementary Wiring Diagram 900 HP for LVD Models Asia Design	96
FIGURE 45 - Adaptive Capacity Control Board For Optiview Control Center	99
FIGURE 46 - Adaptive Capacity Control Board.....	100
FIGURE 47 - 270/292/351/424 HP Drive IGBT Module Verification #1.....	130
FIGURE 48 - 270/292/351/424 HP Drive IGBT Module Verification #2.....	131
FIGURE 49 - 270/292/351/424 HP Drive IGBT Module Verification #3.....	132
FIGURE 50 - 385/419/503/608/658/704/900 HP Drive IGBT Module Verification #1.....	133
FIGURE 51 - 385/419/503/608/658/704/900 HP Drive IGBT Module Verification #2.....	134
FIGURE 52 - 385/419/503/608/658/704/900 HP Drive IGBT Module Verification #3.....	135
FIGURE 53 - OSCD Power Module	137

LIST OF TABLES

TABLE 1 - VSD Part Numbers And Descriptions	4
TABLE 2 - LVD Part Numbers And Descriptions.....	8
TABLE 3 - OSCD - Thermistor Characteristics	113
TABLE 4 - Circuit Breaker Settings For VSD Model Drive.....	123
TABLE 5 - Circuit Breaker Settings For LVD Model Drive	124
TABLE 6 - Software Reference List VSD Models	143
TABLE 7 - Software Reference List LVD Models	146
TABLE 8 - SI Metric Conversion	147

SECTION 1 - OPTISPEED DRIVE COMPONENT OVERVIEW

OPTISPEED COMPRESSOR DRIVE 270, 292, 351 AND 424 HP

The new YORK OptiSpeed Compressor Drive (OSCD) is a liquid cooled, transistorized, PWM inverter in a highly integrated package. This package is small enough to mount directly onto the chiller motor, and small enough to be applied in many retrofit chiller applications. The power section of the drive is composed of four major blocks: an AC to DC rectifier section with an integrated pre-charge circuit, a DC link filter section, a three phase DC to AC inverter section and an output suppression network.

An electronic circuit breaker with ground fault sensing connects the AC line to an AC line inductor and then to the DC converter. The line inductor will limit the amount of fault current so that the electronic circuit breaker is sufficient for protecting the OSCD. Input fuses to the OSCD are no longer needed. The following description of operation is specific to the 351 Hp OSCD, unless otherwise noted. Refer to *Figure 4 on page 18*. The AC to DC semi-converter uses 3 Silicon Controlled Rectifiers (SCR's) and 3 diodes. One SCR and one diode are contained in each module. Three modules are required to convert the 3 phase input AC voltage into DC voltage (1SCR-3SCR) in a three-phase bridge configuration (*Figure 4 on page 18*). The modules are mounted on a liquid cooled heatsink. The use of the SCR's in the semiconverter configuration permits pre-charge of the DC link filter capacitors when the chiller enters the prelube cycle, and they also provides a fast disconnect from the AC line when the chiller enters the coastdown cycle.

When the chiller enters the coastdown cycle the OSCD is turned off, the SCR's in the semi-converter are no longer turned on, and remain in a turned off or nonconducting mode until the next pre-charge cycle. The DC link filter capacitors will start to discharge through the bleeder resistors. When the chiller enters the prelube cycle, the OSCD drive is commanded to pre-charge, the SCR's are gradually turned on with a delay angle to slowly charge the DC link filter capacitors. This is called the pre-charge period, which last for 20-seconds. After the 20-second time period has expired, the SCR's are gated fully on. The SCR Trigger board (031-02060) provides the turn on, and turn off commands for the SCR's during precharge, and during normal running condition as commanded by the OSCD Logic board (031-02077).



Although many of these parts are similar to the parts used in previous Variable Speed Drive (VSD) designs, these parts are only compatible with drives having the base part numbers included on the cover of this form. Failure to use the correct parts may cause major damage to these and other components in the drive. For example, the VSD logic board 031-02077-000 used in this drive is not compatible with 031-01433-000 logic board used in previous designs.

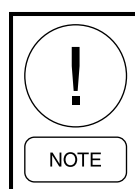

The figures for all horsepower drives are included in this form, but the component identifications are specific for the 351 horsepower drive.

The DC Link filter section of the drive consists of one basic component, a series of electrolytic filter capacitors (C1-C6). These capacitors provide a large energy reservoir for use by the DC to AC inverter section of the OSCD. The capacitors are contained in the OSCD Power Unit. In order to achieve a suitable voltage capability between the DC Link voltage, and the rating of the filter capacitors, two capacitors are placed in series to form a "pair", and then paralleling a suitable number of "pairs" to form a capacitor "bank". In order to assure an equal sharing of the voltage between the series connected capacitors, and to provide a discharge path for the capacitor bank when the OSCD is powered off, "bleeder" resistors (1RES and 2RES) are connected across the capacitor banks. Four bleeder resistors are required on the 575 VAC OSCD. Refer to *Figure 6 on page 22* The "Bleeder" resistors are mounted on the side of the Power Unit.

The DC to AC inverter section of the OSCD serves to convert the DC voltage back to AC voltage at the proper magnitude and frequency as commanded by the OSCD Logic board. The inverter section is actually composed of one power unit. This power unit is composed of very fast switching transistors called an Insulated Gate Bipolar Transistor (IGBT) module (1MOD) mounted on the same liquid cooled heatsink as the semi-converter modules, the DC Link filter capacitors (C1-C6), a semi-converter, and an OSCD Gate Driver board (031- 02061).

The gate driver board conditions the turn on, and turn off commands to the IGBT's output transistors as commanded by the OSCD Logic board. The gate driver board is mounted directly on top of the IGBT module, and it is held in place with mounting screws and soldered to the IGBT module. This improves reliability by eliminating the gate wires and their possible failure.

In order to minimize the parasitic inductance between the IGBT module and the capacitor bank, copper plates which electrically connect the capacitors to one another and to the IGBT module, are connected together using a "laminated bus" structure. This "laminated bus" structure is actually composed of a pair of copper plates sandwiched between and coated with an insulating material acting as the separator/insulator. The "laminated bus" structure forms a parasitic capacitor which acts as a small valued capacitor, effectively canceling the parasitic inductance of the copper plates themselves. To further cancel the parasitic inductances, a series of small film capacitors (C7-C9) are connected between the positive and negative plates at the IGBT module.

The OSCD output suppression network is composed of a series of capacitors (C10-C12) and resistors (3RES-8RES) connected in a three-phase delta configuration. The parameters of the suppression network components are chosen to work in unison with the parasitic inductance of the DC to AC inverter sections in order to simultaneously limit both the rate of change in voltage and the peak voltage applied to the motor windings. By limiting the peak voltage to the motor windings, as well as the rate-of-change in motor voltage, we can avoid problems commonly associated with PWM motor drives, such as stator-winding end-turn failures and electrical fluting of motor bearings.

Other sensors and boards are used to convey information back to the OSCD Logic board, and provide safe operation of the OptiSpeed Compressor Drive. The IGBT module contains a thermistor temperature sensor (RT1) that provides temperature information back to the OSCD logic board via the gate driver board. The AC to DC semi-converter heatsink temperature is also monitored using a thermistor temperature sensor (RT2). This sensor is directly connected to the OSCD Logic Board. The Bus Voltage Isolator board (031-01624) utilizes three resistors on the board to provide a "safe" resistance between the DC link filter capacitors located in the OSCD power unit and the OSCD logic board. It provides the means to sense the positive, midpoint and negative voltage connection points of the OSCD DC link. Three Current Transformers (3T-5T) monitor the

output current from the OSCD power unit and are used to protect the motor from overcurrent conditions.

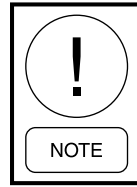

The 575 VAC OSCD require different part number boards than the 460 VAC OSCD or the 50Hz OSCD.

OptiSpeed Compressor Drive 385, 419, 503, 608, 658, 704, and 900 HP

The 385, 419, 503, 608, 658, 704 and 900 Hp OSCD's function in the same manner as the 270, 292, 351, and 424 Hp and have the same components, but more of them. The power requirements of these higher horse power drives require more capacitors in the DC Link, and 3 IGBT modules are needed. One module is used for each output phase. Each IGBT module contains a thermistor, and they are connected to the OSCD logic board. The IGBT gate driver board is mounted on top of the IGBT module as in the 351 Hp, but it only contains 2 drivers. The modules and the boards are not interchangeable between the different horsepower drives.

575 VAC Drive Differences

The 575 VAC drive models are derived from the 460 VAC versions. Although some of the parts are different they perform the same functions. A few changes to the OSCD are required.

First, the input SCR's voltage rating is increased as well as the voltage rating for the Bus caps. The OSCD drive logic is change to accommodate the higher bus voltage. More bleeder resistors of a higher resistance value are required to support the higher bus voltage.

Replacement Parts List (Variable Speed Drive) (Form 160.00-RP4) contains all of the different part numbers required for these products. It is very important not to mix parts between different voltage ranges of OSCD.

Differences for the VSD and LVD model numbers:

See NOMENCLATURE on page 4. Within the drive model number nomenclature there are 2 different letters for the design center of the drive. A 'G' for the design center is a drive that is designed to the UL and CE requirements. A 'W' for the design center is a drive that is designed to standards that govern products built for the Chinese market. The way the drive functions, protects itself, and the motor are the same for both designs.

The 'W' design takes advantage of local components, and local manufacturing. The cooling system is the area where most of the changes occur between the 'G' and 'W' designs. The 'W' design solves the problem of reduce cooling because of 50 Hz power by using a large cooling fan and a different cooling pump. The cooling fan and pump require a 230 VAC 50 Hz source. This higher power source allows the fan and pump to provide the same amount of cooling as the 60 Hz application. The 230 VAC source is provided by an additional voltage tap in the control transformer. This new transformer provides the voltage required for the 230 VAC and 120 VAC components.

Differences for the VSD and LVD model drives:

The VSD model drives are designed so that the harmonic filter system can be included in the drive enclosure. The VSD model also contains the control wiring, additional cooling capacity, and pre-charge circuit for the harmonic filter system, regardless if the harmonic filter system is installed or not. This method provides support for an upgrade for the harmonic filter system later if the customer desires. The LVD model does not contain any support for the harmonic filter system. The enclosure size is reduced, and the harmonic filter cannot be added as an option later. The function of the drive is identical between the 2 designs.

VSD Logic Board History

The VSD model of drives has used 3 basic revisions for the drive logic board. The boards are backward compatible, but newer designs may contains features that are only available with newer control panels. The first drive logic board used on the VSD model of drives has a part number of 031-02077-000 and later a 031-02077-001. Part number 031-02077-000 support 50 and 60 Hz drive models. Part number 031-02077-001 was developed to support drives that require a 575 VAC input voltage. Changes were made to the bus voltage scaling in the 031-02077-001 design.

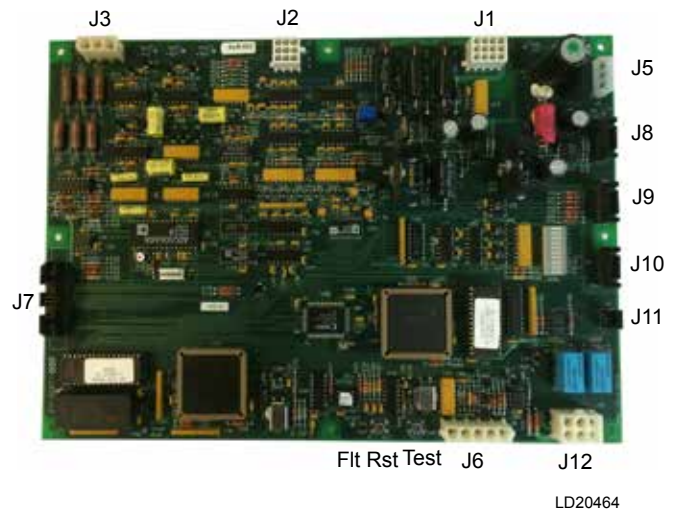

FIGURE 1 - VSD MODEL DRIVE LOGIC BOARD
 031-02077-000, 031-02077-001

Definitions of Connector and Components:

- | | |
|-----------------------------------------|------------------------------------------------------------------------------------------------|
| J1: Motor Current Input | A: Full Load Potentiometer (must be adjusted for each chiller application) |
| J2: Baseplate Temperature Input | B: PWM Microprocessor |
| J3: Bus Voltage Input | C: Software for PWM Microprocessor U45 (Different software required for 50/60 Hz applications) |
| J4: Manufacturing Test Interface | D: Status LED's |
| J5: Logic Board Control Power Input | E: Battery Backed RAM |
| J6: SCR Trigger Interface | F: Main Microprocessor Software U34 |
| J7: Optional Harmonic Filter Interface | G: Main Microprocessor |
| J8: 'A' Phase Gate Driver Interface | |
| J9: 'B' Phase Gate Driver Interface | |
| J10: 'C' Phase Gate Driver Interface | |
| J11: Communication Link (York Protocol) | |
| J12: Hardware Run and Hardware Fault | |

The 031-02077 board was replaced by the 031-02506 board. The main microprocessor became obsolete. A redesign was required to replace the microprocessor. Part number 031-02506-002 replaces 031-02077-000, and 031-02506-003 replaces 031-02077-001. Service parts will supersede original part numbers with new kits that include a new board and software. The new board design performs the same functions as the original design.



FIGURE 2 - VSD MODEL DRIVE LOGIC BOARD
031-02506-002, 031-02506-003

Additional features are listed below:

- All test points for power supplies are located in one location (Upper right hand corner of the board).
- **J16** was added to support ModBus communications to the Control Panel.
- Communications LED's, TX1 and RX2 were added to indicate ModBus communications with the control panel. TX0 and RX0 indicate communications during engineering evaluation.
- **J15** was added to support direct communications to the Harmonic Filter option.
- Communications LED's, (TXF, RXF and FRM) were added to indicate communications from the Harmonic Filter Logic board to the Drive Logic board.
- The ModBus communications system requires that each device has an address. SW3 provides the address for the Drive Logic board. Position #1 should be set to "ON". All other switches should be set to the "OFF" position.

- Battery Backed RAM
- Main Microprocessor Software U34 – The software and the chip technology are not compatible with the 031-02077 board.
- Software for PWM Microprocessor U45 - The software and the chip technology are not compatible with the 031-02077 board.
- D: 50/60 Hz switch was added. The main microprocessor now contains all the software required for 50/60 Hz operation.
- Two pin jumper was added to support Refrigeration applications. The jumper must be installed on both pins for the Refrigeration application.
- Status LED's now include a LED for the status of the fault relay (K1). The LED is not lit when the drive is reporting a fault.

The revision level 'F' of the 031-02506-00x board occurred because the PWM microprocessor became obsolete. The new board design performs the same functions as the original design.



FIGURE 3 - VSD MODEL DRIVE LOGIC BOARD
031-02506-002, 031-02506-003
REVISION 'F' OR LATER

Additional features are listed below:



- These connectors were added to support a Fiber Optic communications system with the control panel. This is a feature that maybe used in the future.
- New software for the PWM microprocessor U22.



- C. New 3 pin jumper for the selection of 50/60 Hz. Pins 1-2 is for 60 Hz applications. Pins 2-3 is for 50 Hz applications. We found that sometimes that switch would get coating in it and not work properly.
- D. New 3 pin jumper for the refrigeration application. The 2 pin jumper did not work well.

- E. SW-3 position #8 is being used to selection the type of ModBus communications RTU/ASCII. The current design requires position #8 to be placed into the 'ON' Position.

NOTES / LEGEND

Notes:

1. Field wiring to be in accordance with the national electric code as well as all other applicable codes and specifications.
2. Terminal board connection points are indicated by numbers within a square. That is,  TB2 main power connection points are indicated by numbers within a hexagon, that is,  component terminal markings are indicated by numbers within a circle, that is,  numbers adjacent to circuit lines are the circuit identification numbers.
3. Terminals L1, L2, L3 and GRD are the main power input terminals and are field connected. (See Note 6). Terminals T1, T2 & T3 are the compressor motor lead power terminals and are factory connected on factory packaged units.
4. The three phase solid state motor overload protection system provides motor overcurrent protection at 105% full load amps.
5. See York control center wiring diagram product drawing forms 160.48-PA21 or 160.52-PW3.
6. Field wiring connections per product drawing forms 160.48-PA15 or 160.48-PW12.
7. Elementary diagram SHT.1 does not show all components relating to the optional harmonic filter components. The connection diagram, SHT. 2, does show all the components relating to the optional harmonic filter. Refer to the wiring label 035-18110-000 for wiring related specifically to the optional filter.
8. To determine if you have a York protocol or modbus protocol model refer to drawing 035-21565-000 and compare your logic BD. wiring to that on the drawing.

LABEL	DESCRIPTION
C1-C6	CAPACITORS, ALUMINUM ELECTROLYTIC, 12,000 UF, 450 VDC
C7-C9	CAPACITORS, FILM, I.O UF, 1200 VDC
C10-C12	CAPACITORS, FILM, 0.047 UF, 560 VAC
1FU-3FU	VYPER TRIGGER/OIL PUMP SUPPLY FUSES
4FU-5FU	CONTROL SUPPLY TRANSFORMER FUSES, 15A, 500V
6FU	EXTERNAL CONTROL SUPPLY TRANSFORMER SECONDARY FUSE, 20A, 500V
7FU	INTERNAL CONTROL SUPPLY TRANSFORMER SECONDARY FUSE, 10A, 500V
IL	VSD AC INDUCTOR, 115 uH PER PHASE, 400A
1MOD	IGBT MODULE, 3 PHASE. 450A, 1200V
1RES-2RES	RESISTORS, PRECHARGE(HARMONIC FILTER) 10Ω, 100W
3RES - 8RES	DV/DT RESISTORS, 10Ω, 100W
9RES - 11RES	RESISTORS, PRECHARGE (HARMONIC FILTER), 10Ω, 375W
RT1 - RT2	THERMISTOR TEMPERATURE SENSORS
ISCR - 3SCR	SCR/DIODE MODULES, 1200V, 210A
IR	RELAY, COOLING FANS AND PUMP CIRCUIT BREAKER, 600V, 400A, 100% RATED
ISW	120VAC, 3KVA CONTROL POWER TRANSFORMER
IT	120VAC, 3KVA CONTROL POWER TRANSFORMER
2T, 8T	24VAC, 75VA CO NTROL TRANSFORMER
3T - 5T	OUTPUT CURRENT TRANSFORMERS
1TB - 2TB	TERMINAL BLOCKS, FIELD WIRING
	JACK, JI-I ETC.
	PLUG, PI-I ETC.

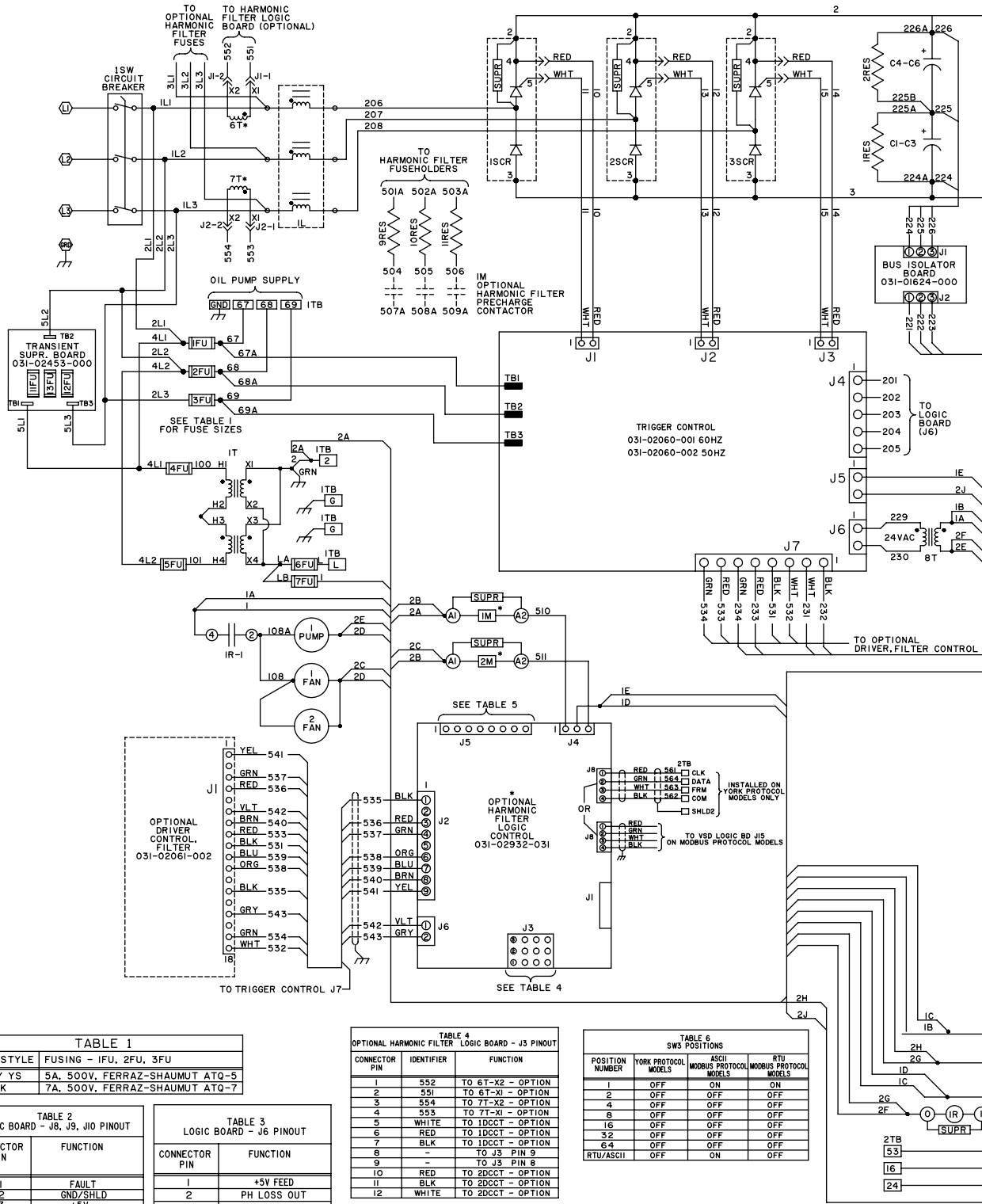

TABLE 1
UNIT STYLE FUSING - IFU, 2FU, 3FU

YT / YS	5A, 500V, FERRAZ-SHAUMUT ATQ-5
YK	7A, 500V, FERRAZ-SHAUMUT ATQ-7

TABLE 2
LOGIC BOARD - J8, J9, J10 PINOUT

CONNECTOR PIN	FUNCTION
1	FAULT
2	GND/SHLD
3	+5V
4	UPPER PHASE
5	LOWER PHASE
6	SW, +7.5V
7	GND/SHLD

NOTE: GND/SHLD NOT CONNECTED AT DRIVER CONTROL END

TABLE 3
LOGIC BOARD - J6 PINOUT

CONNECTOR PIN	FUNCTION
1	+5V FEED
2	PH LOSS OUT
3	PRECHG IN
4	SCRTRIG IN
5	+7.5V FEED

TABLE 4
OPTIONAL HARMONIC FILTER LOGIC BOARD - J3 PINOUT

CONNECTOR PIN	IDENTIFIER	FUNCTION
1	552	TO 6T-X2 - OPTION
2	551	TO 6T-X1 - OPTION
3	554	TO 7T-X2 - OPTION
4	553	TO 7T-X1 - OPTION
5	WHITE	TO IDCCCT - OPTION
6	RED	TO IDCCCT - OPTION
7	BLK	TO IDCCCT - OPTION
8	-	TO J3 PIN 9
9	-	TO J3 PIN 8
10	RED	TO 2DCCT - OPTION
11	BLK	TO 2DCCT - OPTION
12	WHITE	TO 2DCCT - OPTION

TABLE 5
OPTIONAL HARMONIC FILTER LOGIC BOARD - J5 PINOUT

CONNECTOR PIN	IDENTIFIER	FUNCTION
1	530	TO J2-1, OPTIONAL 2022 BOARD
2	529	TO J2-2, OPTIONAL 2022 BOARD
3	528	TO J2-3, OPTIONAL 2022 BOARD
4	527	TO J2-4, OPTIONAL 2022 BOARD
5	523	TO J2-3, OPTIONAL I624 BOARD
6	522	TO J2-2, OPTIONAL I624 BOARD
7	521	TO J2-1, OPTIONAL I624 BOARD
8	-	NOT USED

TABLE 6
SWS POSITIONS

POSITION NUMBER	YORK PROTOCOL MODELS	ASCII MODBUS PROTOCOL MODELS	RTU MODBUS PROTOCOL MODELS
1	OFF	ON	ON
2	OFF	OFF	OFF
4	OFF	OFF	OFF
8	OFF	OFF	OFF
16	OFF	OFF	OFF
32	OFF	OFF	OFF
64	OFF	OFF	OFF
RTU/ASCII	OFF	ON	OFF

LD19427

FIGURE 4 - ELEMENTARY WIRING DIAGRAM 270, 292 AND 351 HP FOR VSD MODELS GLOBAL DESIGN MANUFACTURED AFTER DECEMBER 2006

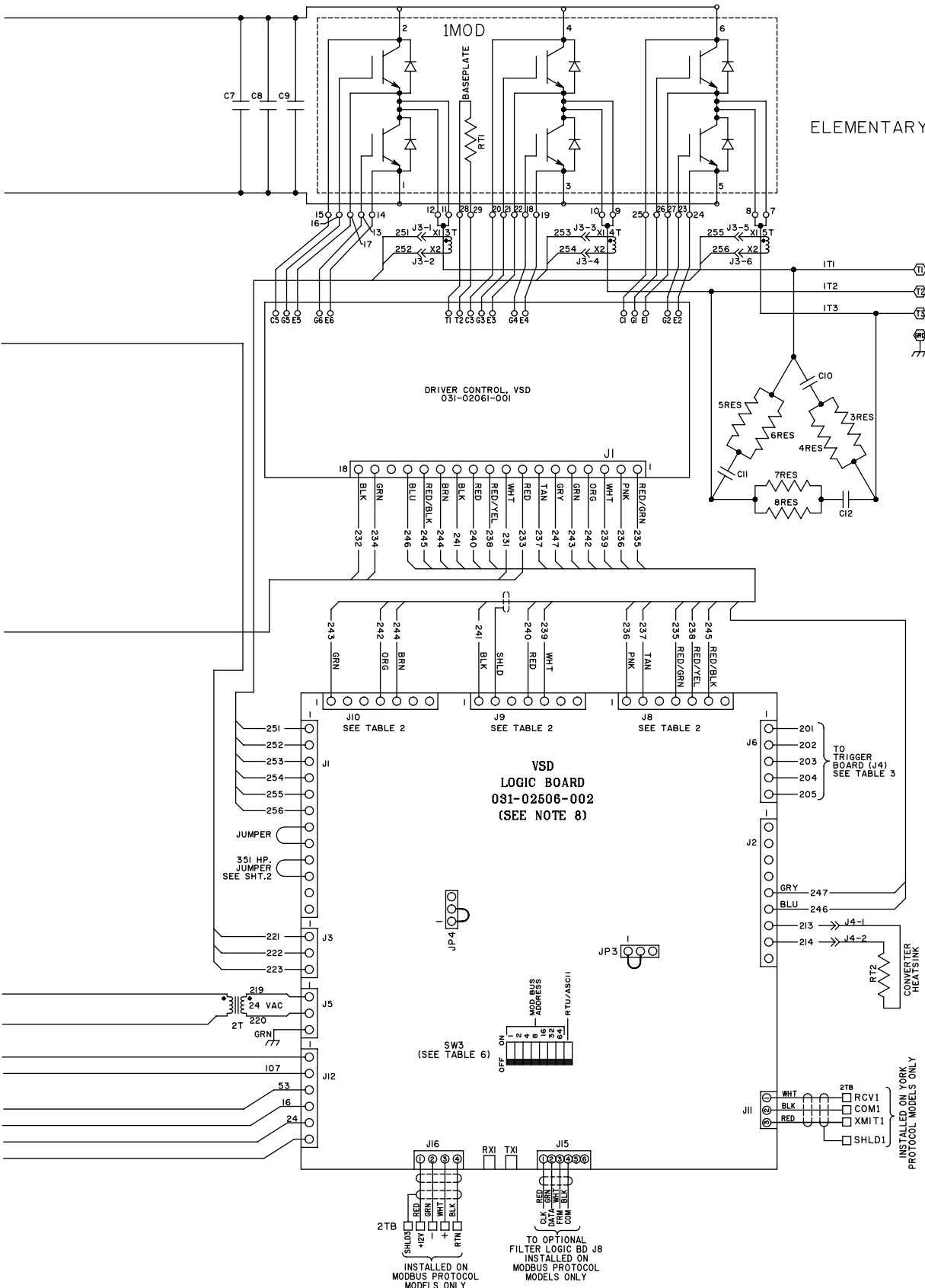

ELEMENTARY WIRING DIAGRAM

FIGURE 4 -ELEMENTARY WIRING DIAGRAM 270, 292 AND 351 HP FOR VSD MODELS GLOBAL DESIGN MANUFACTURED AFTER DECEMBER 2006 (CONT'D)

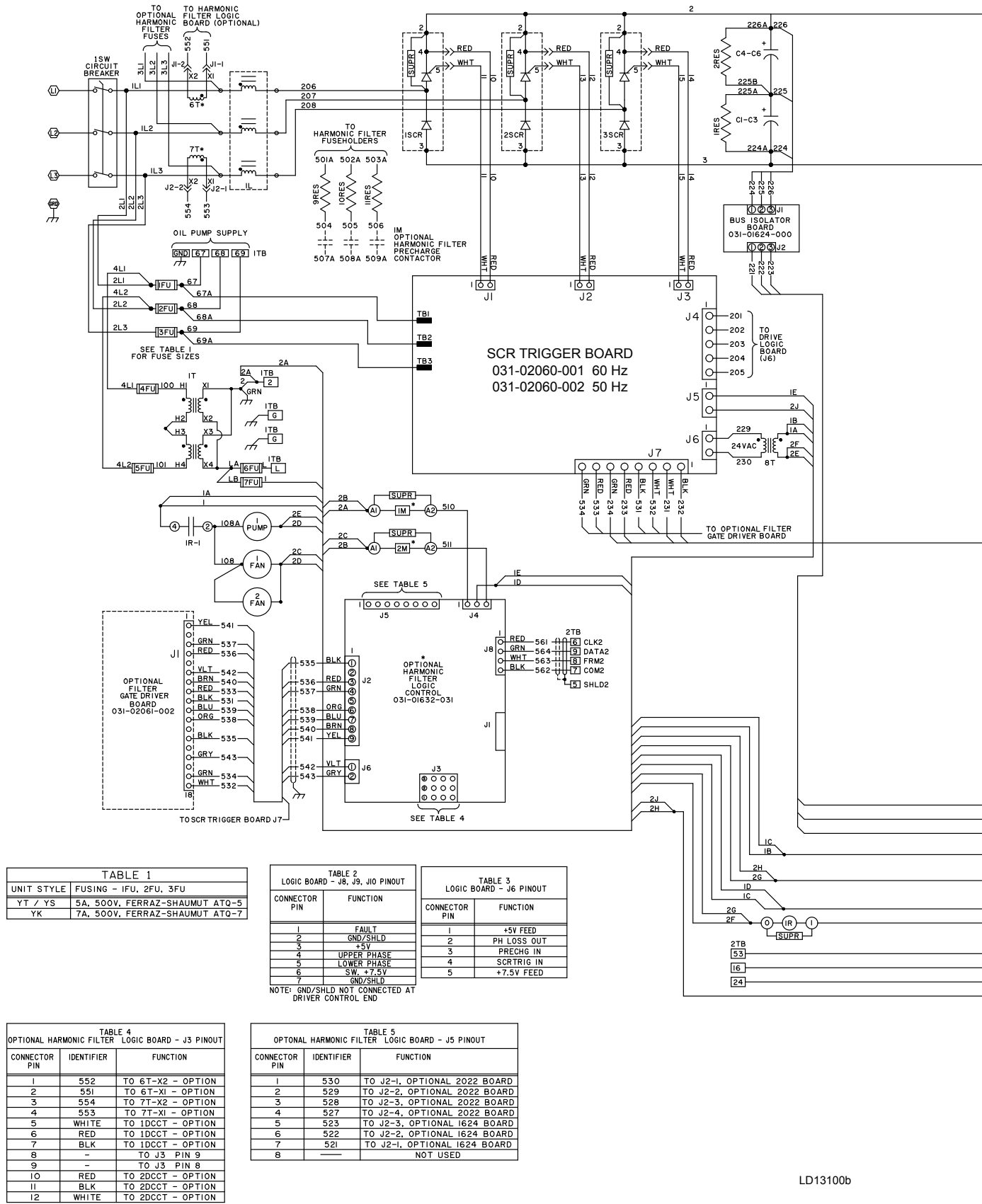

TABLE 1
UNIT STYLE FUSING - 1FU, 2FU, 3FU

YT / YS	5A, 500V, FERRAZ-SHAUMUT ATQ-5
YK	7A, 500V, FERRAZ-SHAUMUT ATQ-7

TABLE 2
LOGIC BOARD - J8, J9, J10 PINOUT

CONNECTOR PIN	FUNCTION
1	FAULT
2	GND/SHLD
3	+5V
4	UPPER PHASE
5	LOWER PHASE
6	SW +7.5V
7	GND/SHLD

NOTE: GND/SHLD NOT CONNECTED AT DRIVER CONTROL END

TABLE 3
LOGIC BOARD - J6 PINOUT

CONNECTOR PIN	FUNCTION
1	+5V FEED
2	PH LOSS OUT
3	PRECHG IN
4	SCRTRIG IN
5	+7.5V FEED

TABLE 4
OPTIONAL HARMONIC FILTER LOGIC BOARD - J3 PINOUT

CONNECTOR PIN	IDENTIFIER	FUNCTION
1	552	TO 6T-X2 - OPTION
2	551	TO 6T-XI - OPTION
3	554	TO 7T-X2 - OPTION
4	553	TO 7T-XI - OPTION
5	WHITE	TO 1DCCT - OPTION
6	RED	TO 1DCCT - OPTION
7	BLK	TO 1DCCT - OPTION
8	-	TO J3 PIN 9
9	-	TO J3 PIN 8
10	RED	TO 2DCCT - OPTION
11	BLK	TO 2DCCT - OPTION
12	WHITE	TO 2DCCT - OPTION

TABLE 5
OPTIONAL HARMONIC FILTER LOGIC BOARD - J5 PINOUT

CONNECTOR PIN	IDENTIFIER	FUNCTION
1	530	TO J2-1, OPTIONAL 2022 BOARD
2	529	TO J2-2, OPTIONAL 2022 BOARD
3	528	TO J2-3, OPTIONAL 2022 BOARD
4	527	TO J2-4, OPTIONAL 2022 BOARD
5	523	TO J2-3, OPTIONAL 1624 BOARD
6	522	TO J2-2, OPTIONAL 1624 BOARD
7	521	TO J2-1, OPTIONAL 1624 BOARD
8	-	NOT USED

FIGURE 5 - ELEMENTARY WIRING DIAGRAM 270, 292 AND 351 HP FOR VSD MODELS GLOBAL DESIGN MANUFACTURED BEFORE DECEMBER 2006

035-I7889.SHTI
 REV. C

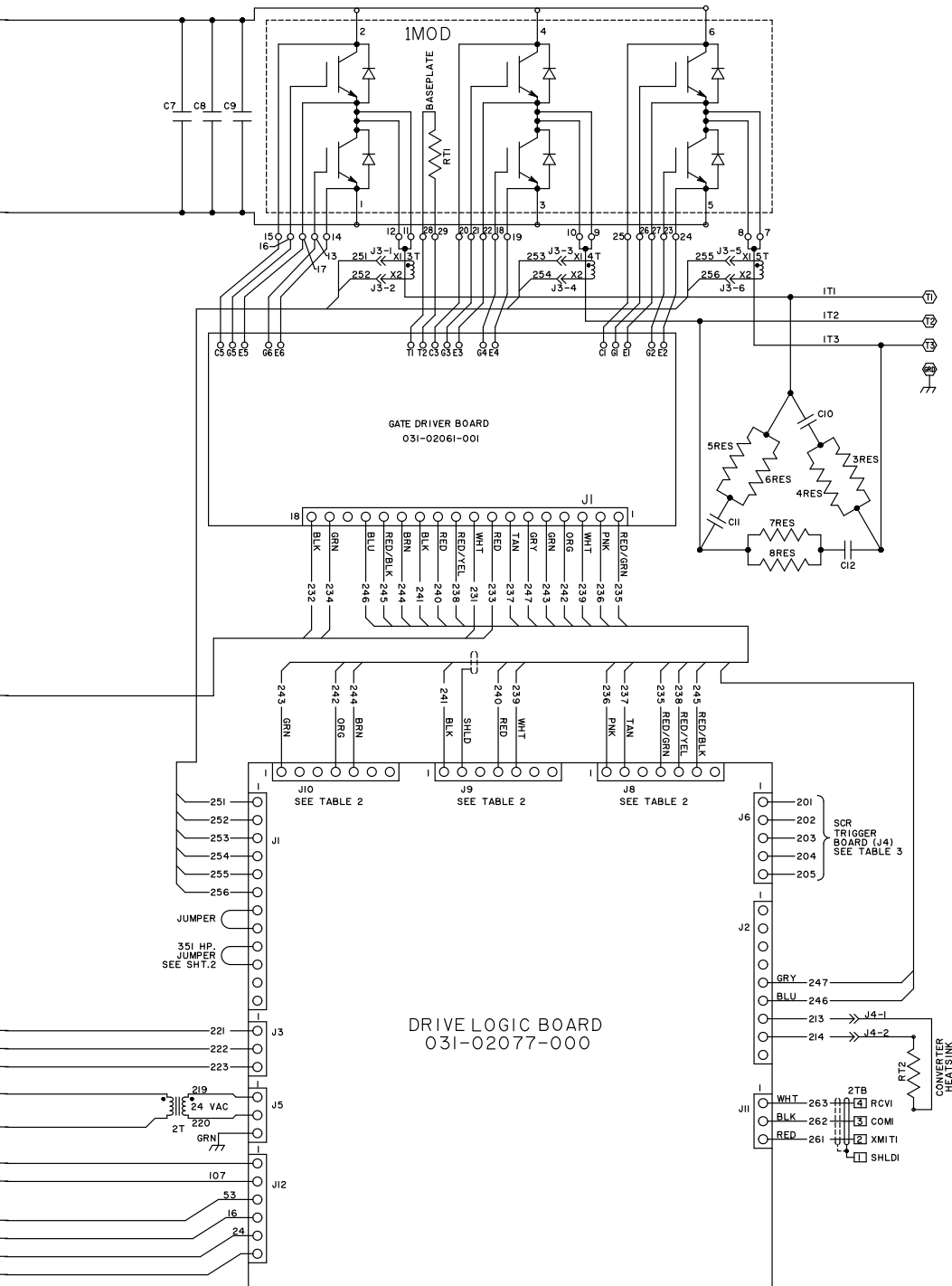

FIGURE 5 - ELEMENTARY WIRING DIAGRAM 270, 292 AND 351 HP FOR VSD MODELS GLOBAL DESIGN MANUFACTURED BEFORE DECEMBER 2006 (CONT'D)

LD13101b

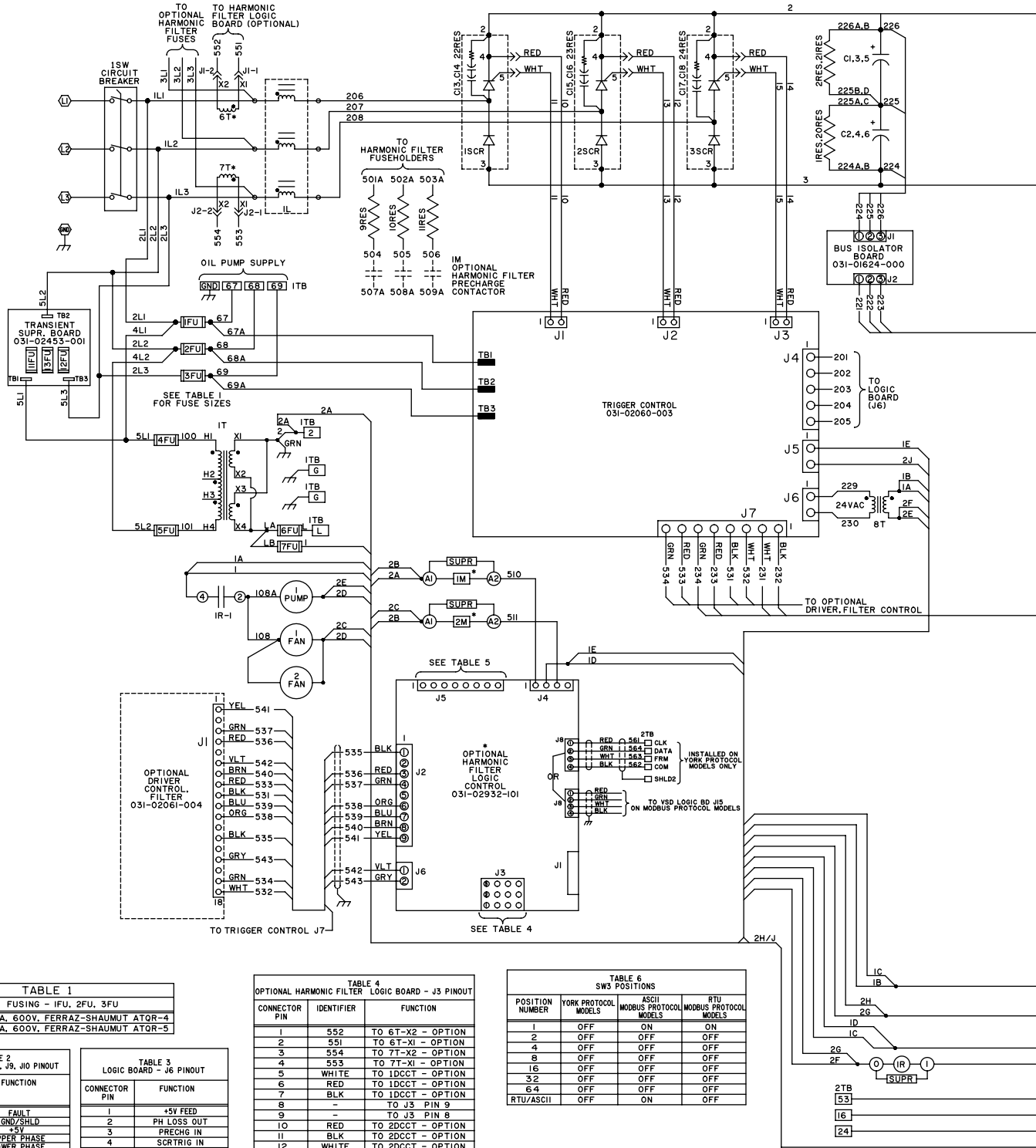

TABLE 1
UNIT STYLE FUSING - IFU, 2FU, 3FU

YT / YS	4A, 600V, FERRAZ-SHAUMUT ATOR-4
YK	5A, 600V, FERRAZ-SHAUMUT ATOR-5

TABLE 2
LOGIC BOARD - J8, J9, J10 PINOUT

CONNECTOR PIN	FUNCTION
1	FAULT
2	GND/SHLD +5V
3	UPPER PHASE
4	LOWER PHASE
5	SW, +7.5V
6	GND/SHLD

NOTE: GND/SHLD NOT CONNECTED AT DRIVER CONTROL END

TABLE 3
LOGIC BOARD - J6 PINOUT

CONNECTOR PIN	FUNCTION
1	+5V FEED
2	PH LOSS OUT
3	PRECHG IN
4	SCRTRIG IN
5	+7.5V FEED

TABLE 4
OPTIONAL HARMONIC FILTER LOGIC BOARD - J3 PINOUT

CONNECTOR PIN	IDENTIFIER	FUNCTION
1	552	TO 6T-X2 - OPTION
2	551	TO 6T-X1 - OPTION
3	554	TO 7T-X2 - OPTION
4	553	TO 7T-X1 - OPTION
5	WHITE	TO 1DCCT - OPTION
6	RED	TO 1DCCT - OPTION
7	BLK	TO 1DCCT - OPTION
8	-	TO J3 PIN 9
9	-	TO J3 PIN 8
10	RED	TO 2DCCT - OPTION
11	BLK	TO 2DCCT - OPTION
12	WHITE	TO 2DCCT - OPTION

TABLE 5
OPTIONAL HARMONIC FILTER LOGIC BOARD - J5 PINOUT

CONNECTOR PIN	IDENTIFIER	FUNCTION
1	530	TO J2-1, OPTIONAL 2022 BOARD
2	529	TO J2-2, OPTIONAL 2022 BOARD
3	528	TO J2-3, OPTIONAL 2022 BOARD
4	527	TO J2-4, OPTIONAL 2022 BOARD
5	523	TO J2-3, OPTIONAL 1624 BOARD
6	522	TO J2-2, OPTIONAL 1624 BOARD
7	521	TO J2-1, OPTIONAL 1624 BOARD
8	-	NOT USED

TABLE 6
SW3 POSITIONS

POSITION NUMBER	YORK PROTOCOL MODELS	ASCII MODBUS PROTOCOL MODELS	RTU MODBUS PROTOCOL MODELS
1	OFF	ON	ON
2	OFF	OFF	OFF
4	OFF	OFF	OFF
8	OFF	OFF	OFF
16	OFF	OFF	OFF
32	OFF	OFF	OFF
64	OFF	OFF	OFF
RTU/ASCII	OFF	ON	OFF

FIGURE 6 - ELEMENTARY WIRING DIAGRAM 424 HP FOR VSD MODELS GLOBAL DESIGN MANUFACTURED AFTER DECEMBER 2006

035-21023-000
 SHEET 1 OF 2
 REV. H

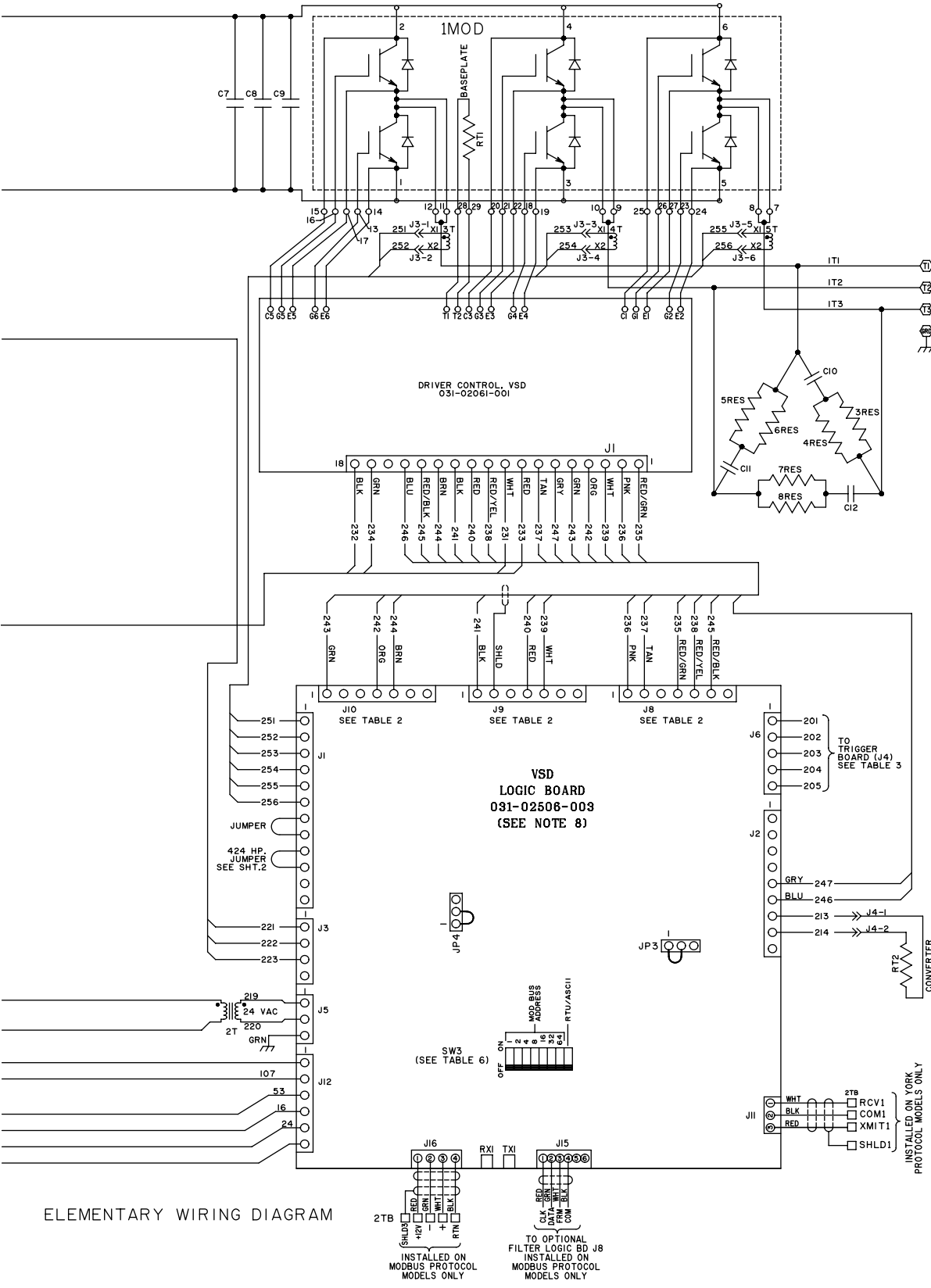

ELEMENTARY WIRING DIAGRAM

FIGURE 6 - ELEMENTARY WIRING DIAGRAM 424 HP FOR VSD MODELS GLOBAL DESIGN MANUFACTURED AFTER DECEMBER 2006 (CONT'D)

LD19430

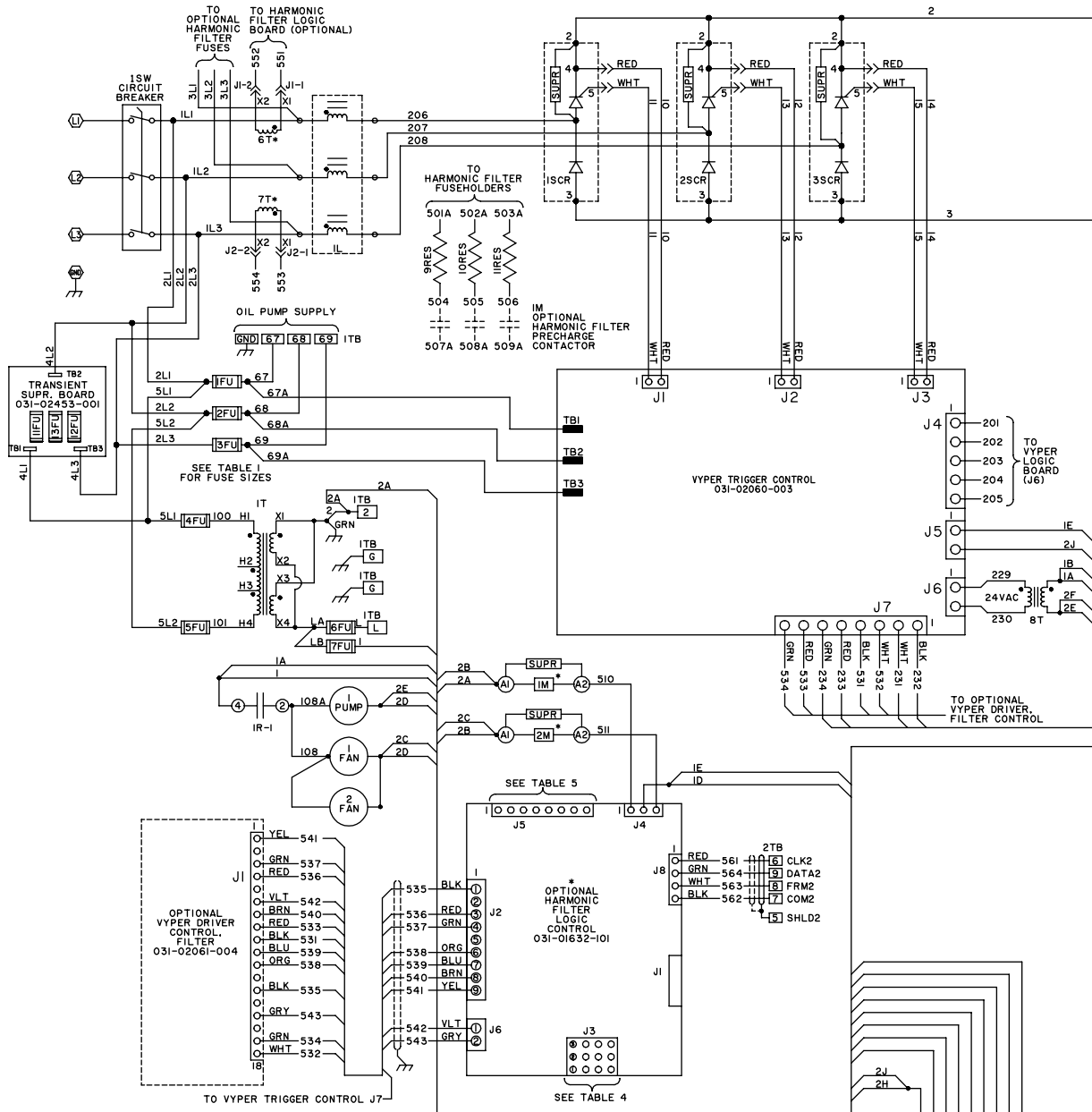

TABLE 1
UNIT STYLE FUSING - IFU, 2FU, 3FU

YT / YS	4A, 600V, FERRAZ-SHAUMUT ATOR-4
YK	3A, 600V, FERRAZ-SHAUMUT ATOR-3

TABLE 4
OPTIONAL HARMONIC FILTER LOGIC BOARD - J3 PINOUT

CONNECTOR PIN	IDENTIFIER	FUNCTION
1	552	TO 6T-X2 - OPTION
2	551	TO 6T-X1 - OPTION
3	554	TO 7T-X2 - OPTION
4	553	TO 7T-X1 - OPTION
5	WHITE	TO IDCCT - OPTION
6	RED	TO IDCCT - OPTION
7	BLK	TO IDCCT - OPTION
8	-	TO J3 PIN 9
9	-	TO J3 PIN 8
10	RED	TO 2DCCT - OPTION
11	BLK	TO 2DCCT - OPTION
12	WHITE	TO 2DCCT - OPTION

TABLE 5
OPTIONAL HARMONIC FILTER LOGIC BOARD - J5 PINOUT

CONNECTOR PIN	IDENTIFIER	FUNCTION
1	530	TO J2-1, OPTIONAL 2022 BOARD
2	529	TO J2-2, OPTIONAL 2022 BOARD
3	528	TO J2-3, OPTIONAL 2022 BOARD
4	527	TO J2-4, OPTIONAL 2022 BOARD
5	523	TO J2-3, OPTIONAL 1624 BOARD
6	522	TO J2-2, OPTIONAL 1624 BOARD
7	521	TO J2-1, OPTIONAL 1624 BOARD
8	-	NOT USED

TABLE 2
VYPERLOGIC BOARD - J8, J9, J10 PINOUT

CONNECTOR PIN	FUNCTION
1	FAULT
2	GND/SHLD
3	+5V
4	UPPER PHASE
5	LOWER PHASE
6	SW, +7.5V
7	GND/SHLD

NOTE: GND/SHLD NOT CONNECTED AT DRIVER CONTROL END

TABLE 3
VYPERLOGIC BOARD - J6 PINOUT

CONNECTOR PIN	FUNCTION
1	+5V FEED
2	PH LOSS OUT
3	PRECHG IN
4	SCRTRIG IN
5	+7.5V FEED

FIGURE 7 - ELEMENTARY WIRING DIAGRAM 424 HP FOR VSD MODELS GLOBAL DESIGN MANUFACTURED BEFORE DECEMBER 2006

LD23155

035-21023.SHT1
 REV. A

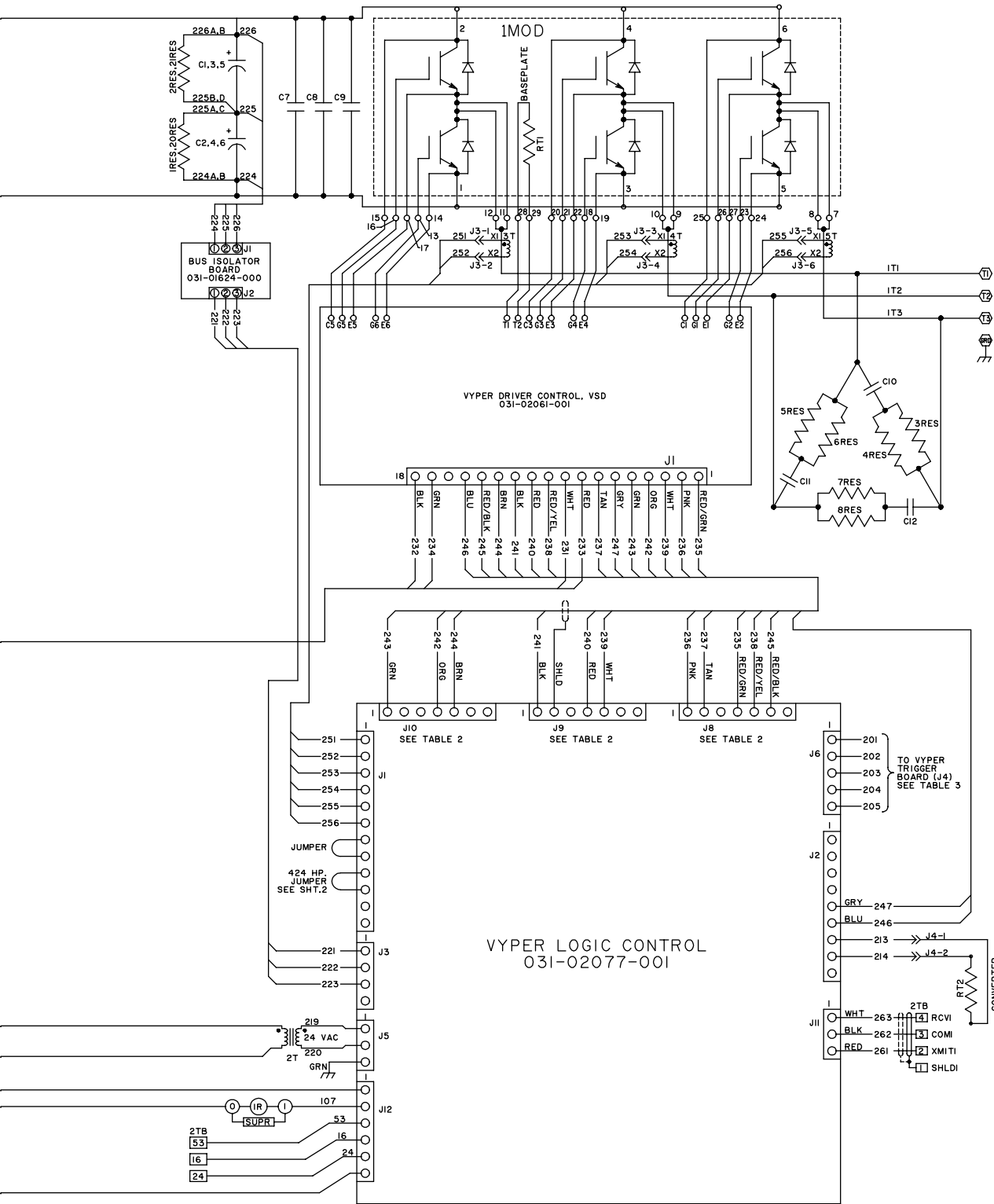

FIGURE 7 - ELEMENTARY WIRING DIAGRAM 424 HP FOR VSD MODELS GLOBAL DESIGN MANUFACTURED BEFORE DECEMBER 2006 (CONT'D)

LD23156

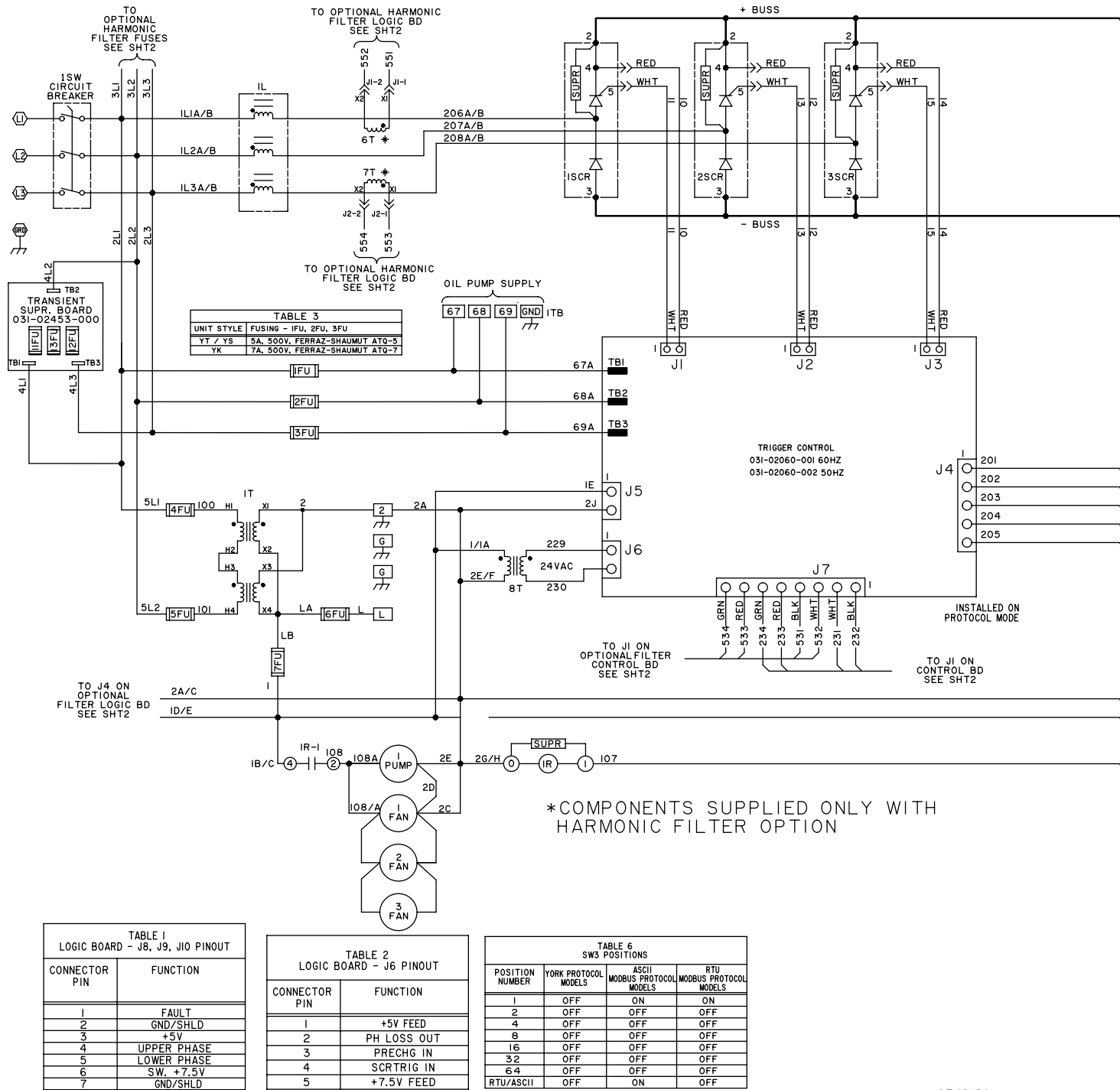
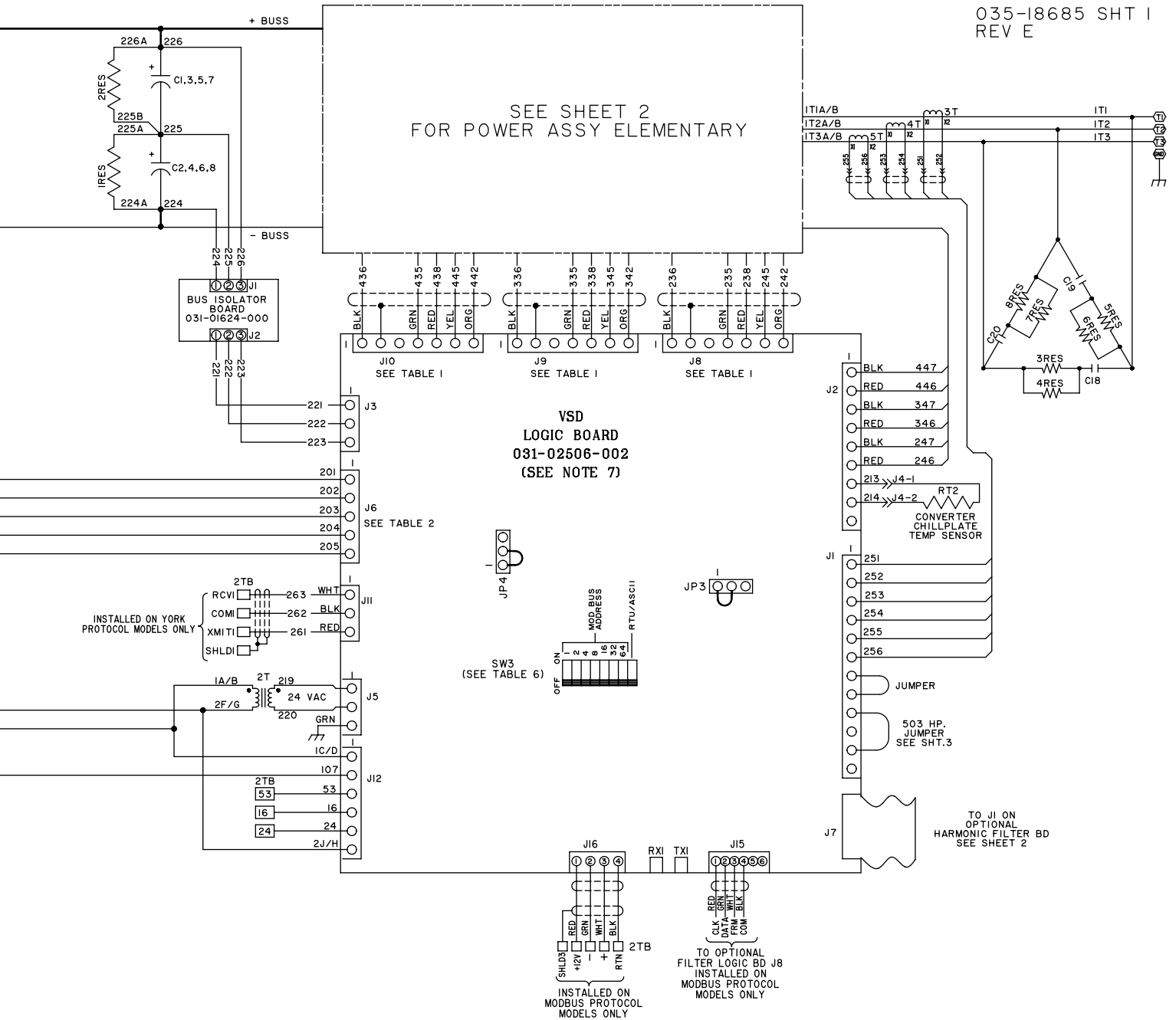

FIGURE 8 - ELEMENTARY WIRING DIAGRAM 385/419/503 HP FOR VSD MODELS GLOBAL DESIGN MANUFACTURED AFTER DECEMBER 2006



**FIGURE 8 - ELEMENTARY WIRING DIAGRAM 385/419/503 HP FOR VSD MODELS GLOBAL DESIGN
 MANUFACTURED AFTER DECEMBER 2006 (CONT'D)**

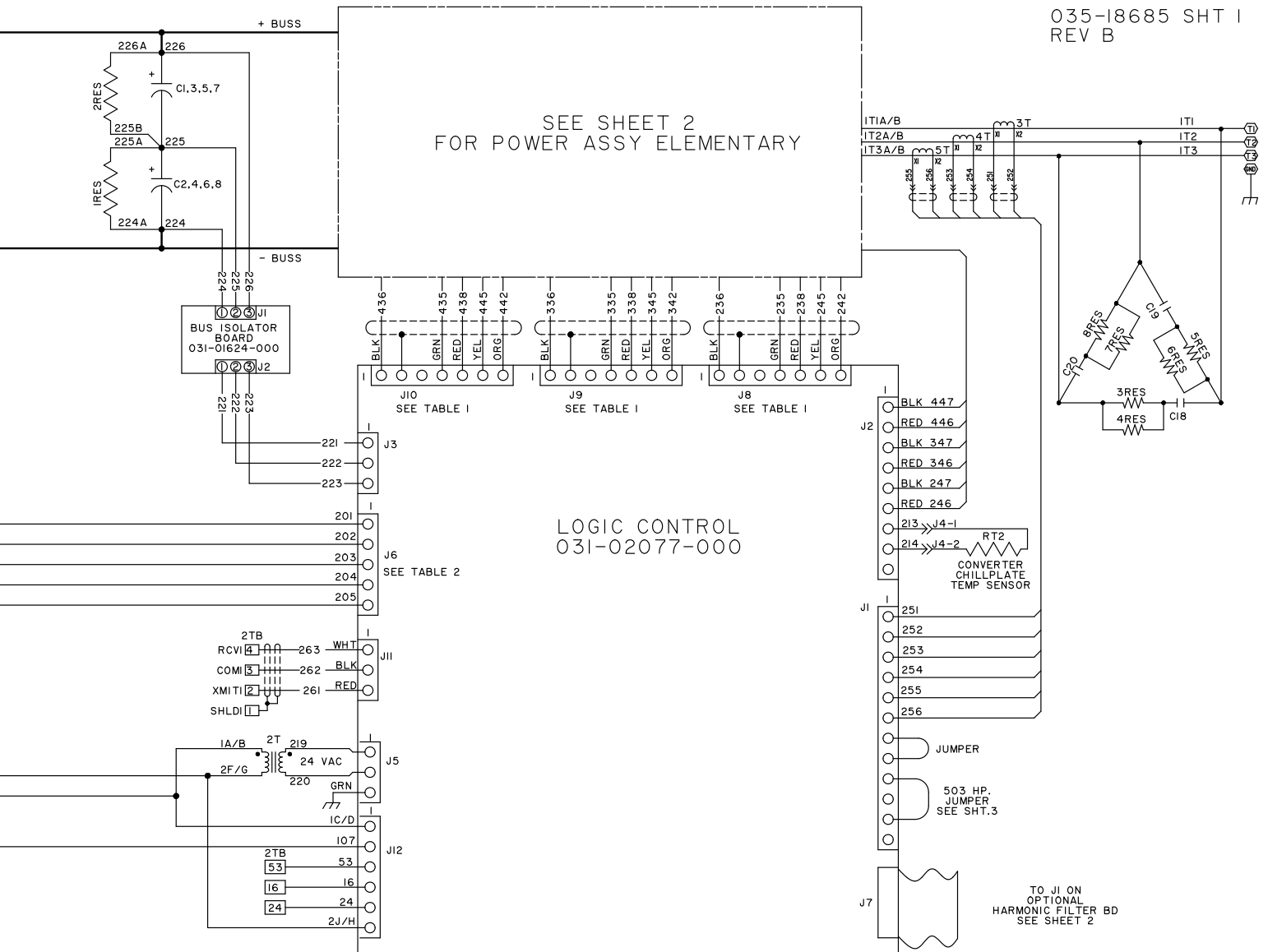

TABLE 1
 LOGIC BOARD - J8, J9, J10 PINOUT

CONNECTOR PIN	FUNCTION
1	FAULT
2	GND/SHLD
3	+5V
4	UPPER PHASE
5	LOWER PHASE
6	SW. +7.5V
7	GND/SHLD

TABLE 2
 LOGIC BOARD - J6 PINOUT

CONNECTOR PIN	FUNCTION
1	+5V FEED
2	PH LOSS OUT
3	PRECHG IN
4	SCRTRIG IN
5	+7.5V FEED

FIGURE 9 - ELEMENTARY WIRING DIAGRAM 385/419/503 HP FOR VSD MODELS GLOBAL DESIGN MANUFACTURED BEFORE DECEMBER 2006 (CONT'D)

LD13105b

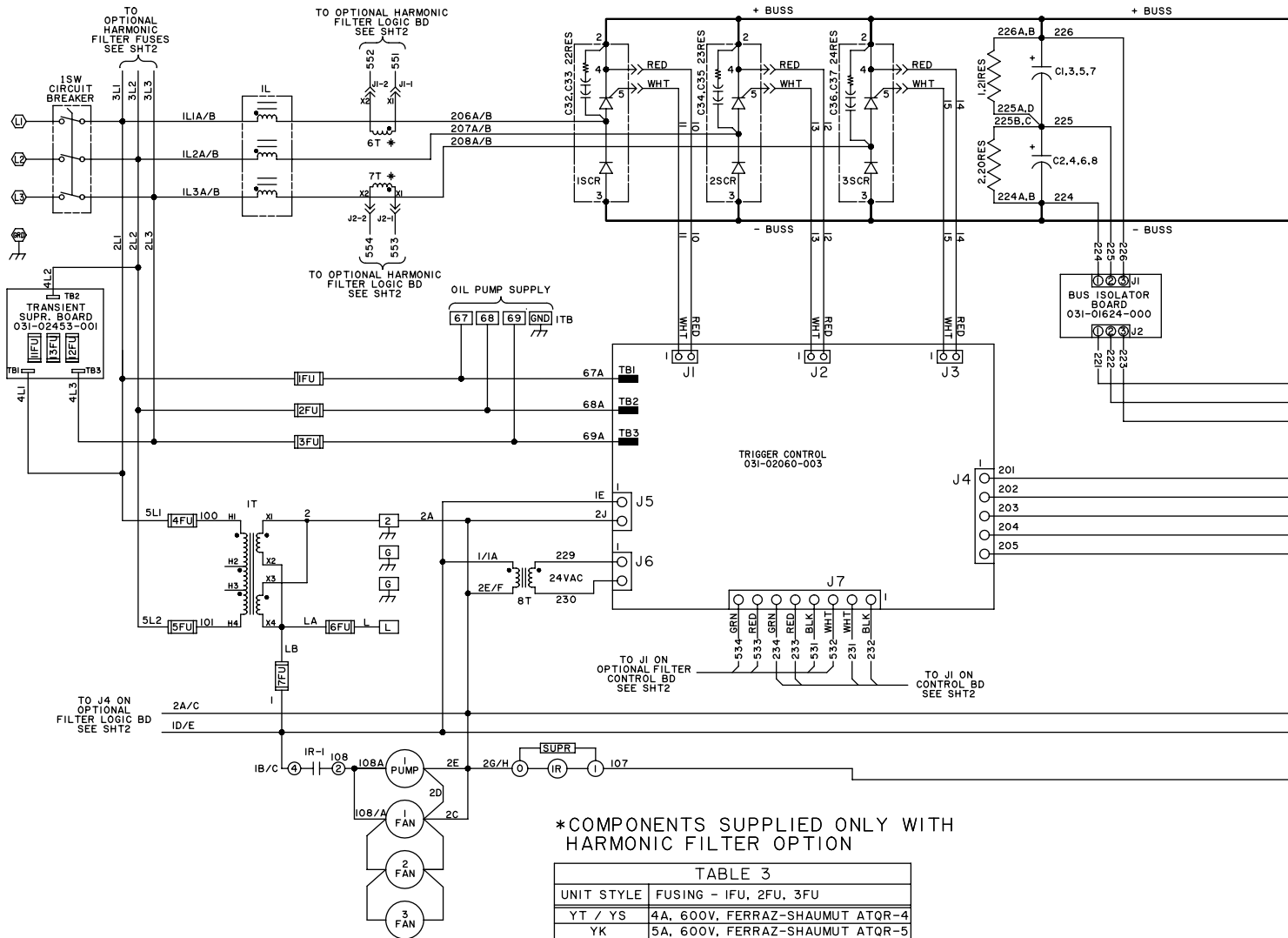

LD19433

FIGURE 10 - ELEMENTARY WIRING DIAGRAM 608 HP FOR VSD MODELS GLOBAL DESIGN MANUFACTURED AFTER DECEMBER 2006

035-21016-000
SHEET 1 OF 3
REV H

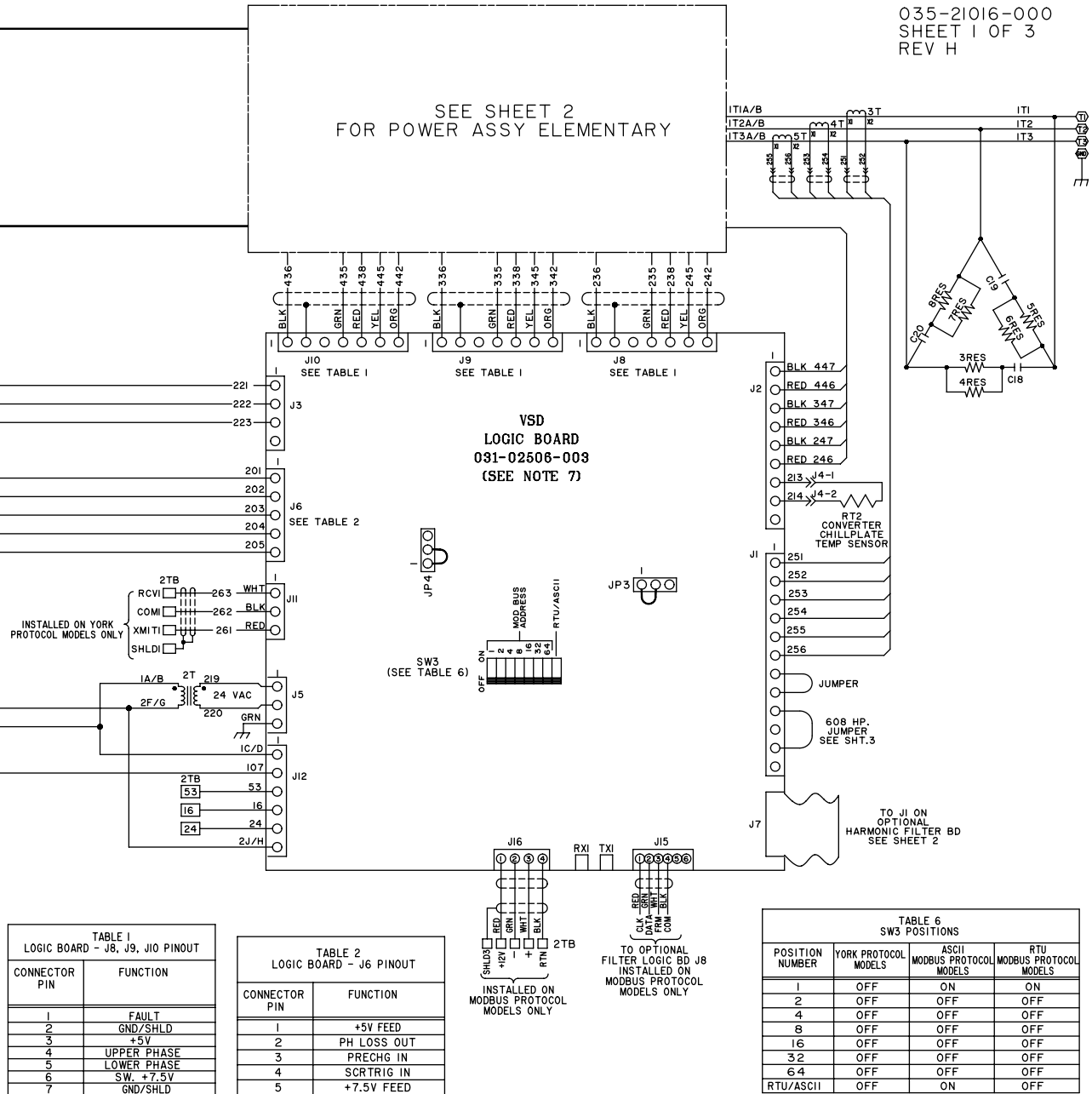
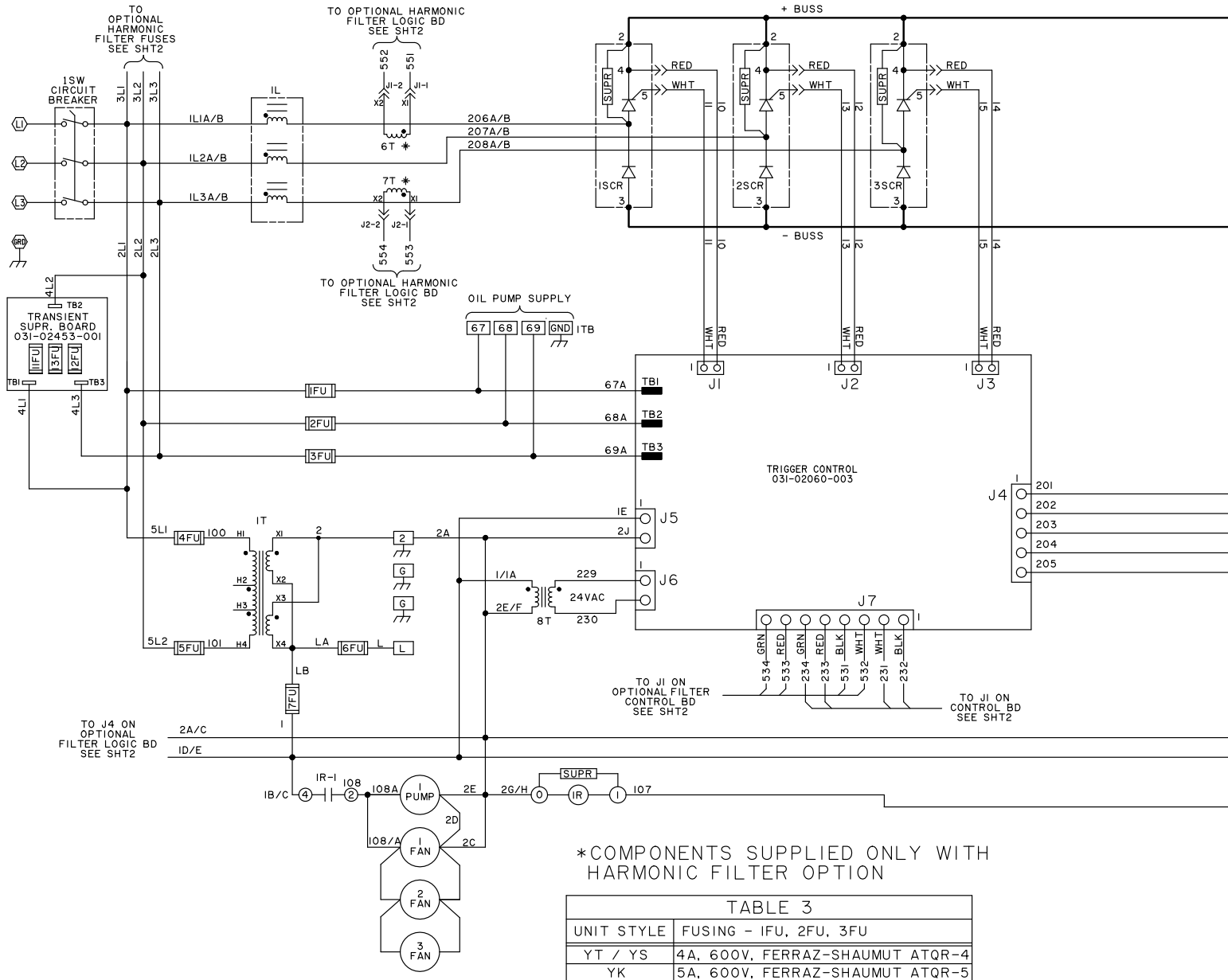

FIGURE 10 - ELEMENTARY WIRING DIAGRAM 608 HP FOR VSD MODELS GLOBAL DESIGN MANUFACTURED AFTER DECEMBER 2006 (CONT'D)



LD13107b

FIGURE 11 - ELEMENTARY WIRING DIAGRAM 608 HP FOR VSD MODELS GLOBAL DESIGN
MANUFACTURED BEFORE DECEMBER 2006

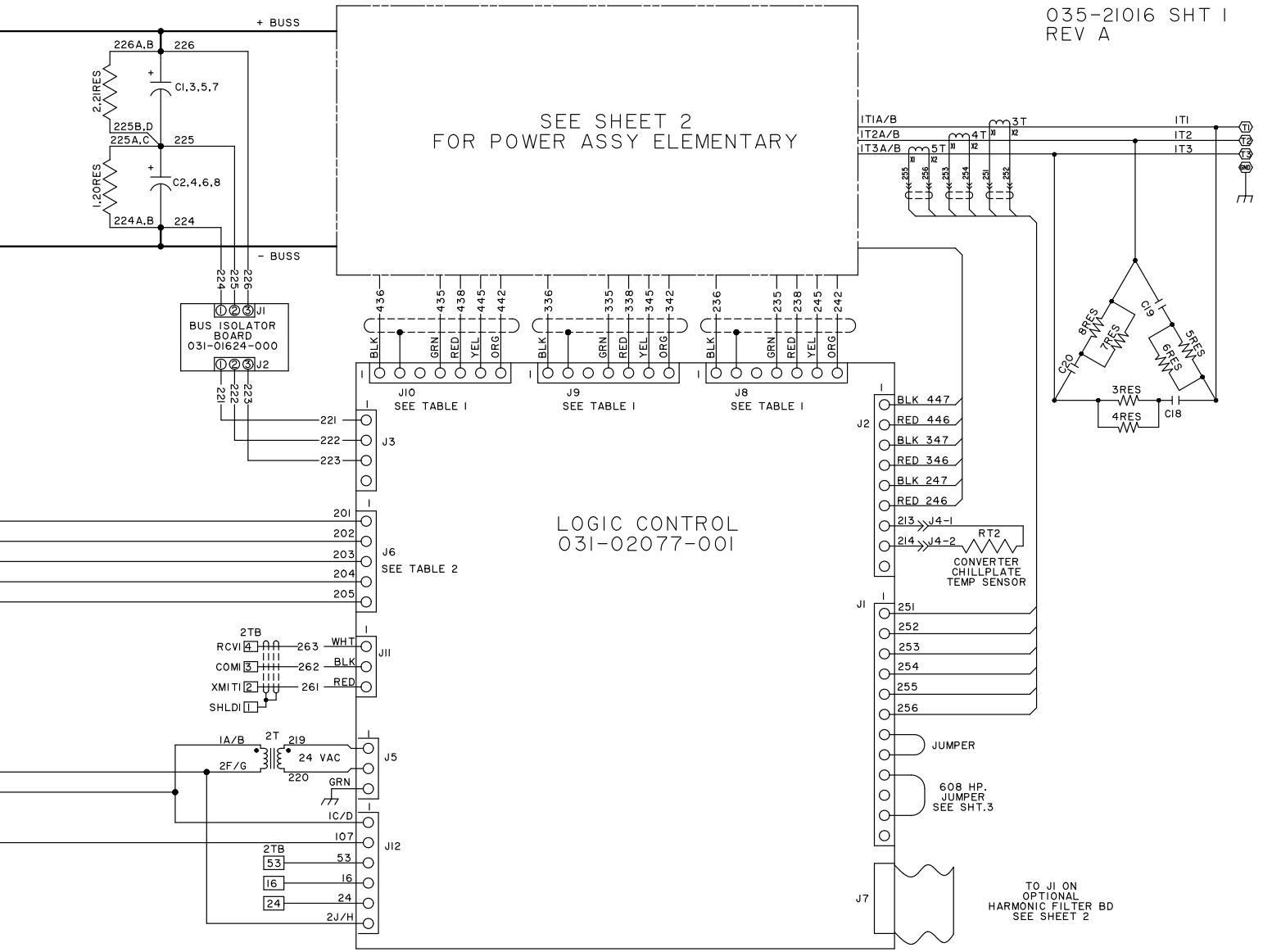

TABLE 1
 LOGIC BOARD - J8, J9, J10 PINOUT

CONNECTOR PIN	FUNCTION
1	FAULT
2	GND/SHLD
3	+5V
4	UPPER PHASE
5	LOWER PHASE
6	SW. +7.5V
7	GND/SHLD

TABLE 2
 LOGIC BOARD - J6 PINOUT

CONNECTOR PIN	FUNCTION
1	+5V FEED
2	PH LOSS OUT
3	PRECHG IN
4	SCRTRIG IN
5	+7.5V FEED

LD13108b

FIGURE 11 - ELEMENTARY WIRING DIAGRAM 608 HP FOR VSD MODELS GLOBAL DESIGN MANUFACTURED BEFORE DECEMBER 2006 (CONT'D)

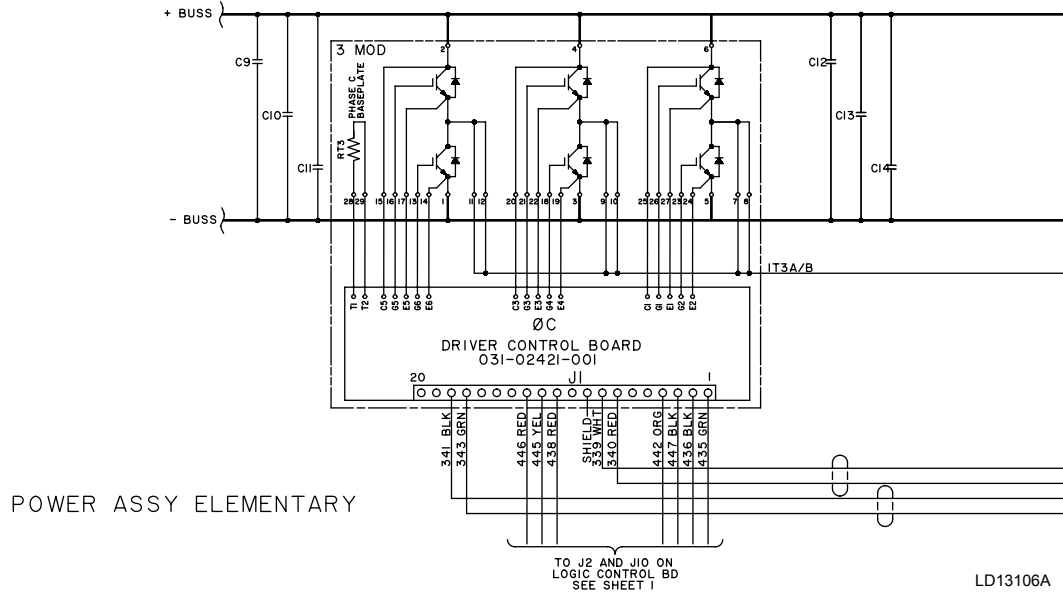

FIGURE 12 - POWER ASSEMBLY ELEMENTARY WIRING DIAGRAM 385/419/503 HP FOR VSD MODELS GLOBAL DESIGN

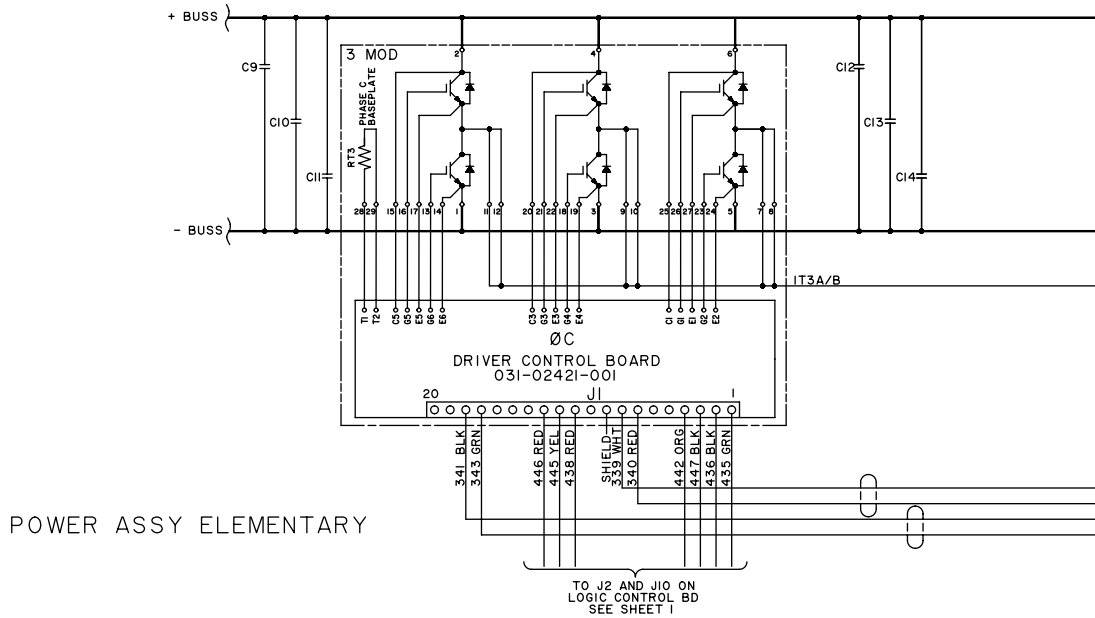

FIGURE 13 - POWER ASSEMBLY ELEMENTARY WIRING DIAGRAM 608 HP FOR VSD MODELS GLOBAL DESIGN

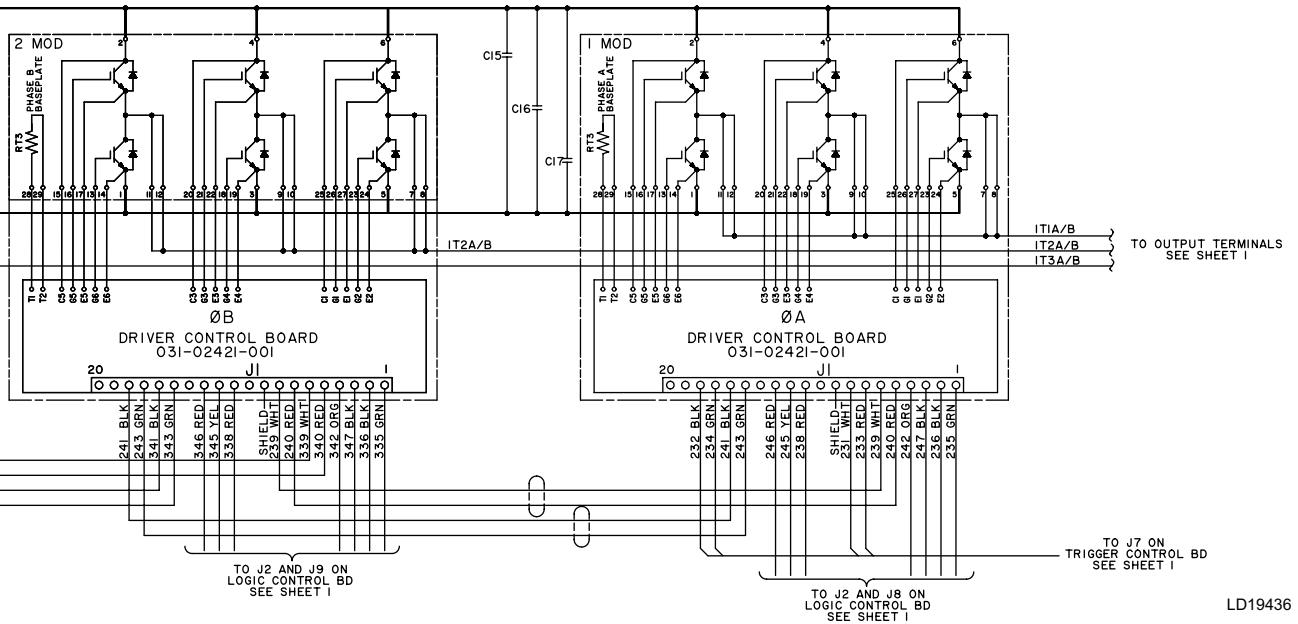

FIGURE 12 - POWER ASSEMBLY ELEMENTARY WIRING DIAGRAM 385/419/503 HP FOR VSD MODELS GLOBAL DESIGN (CONT'D)

LD19436

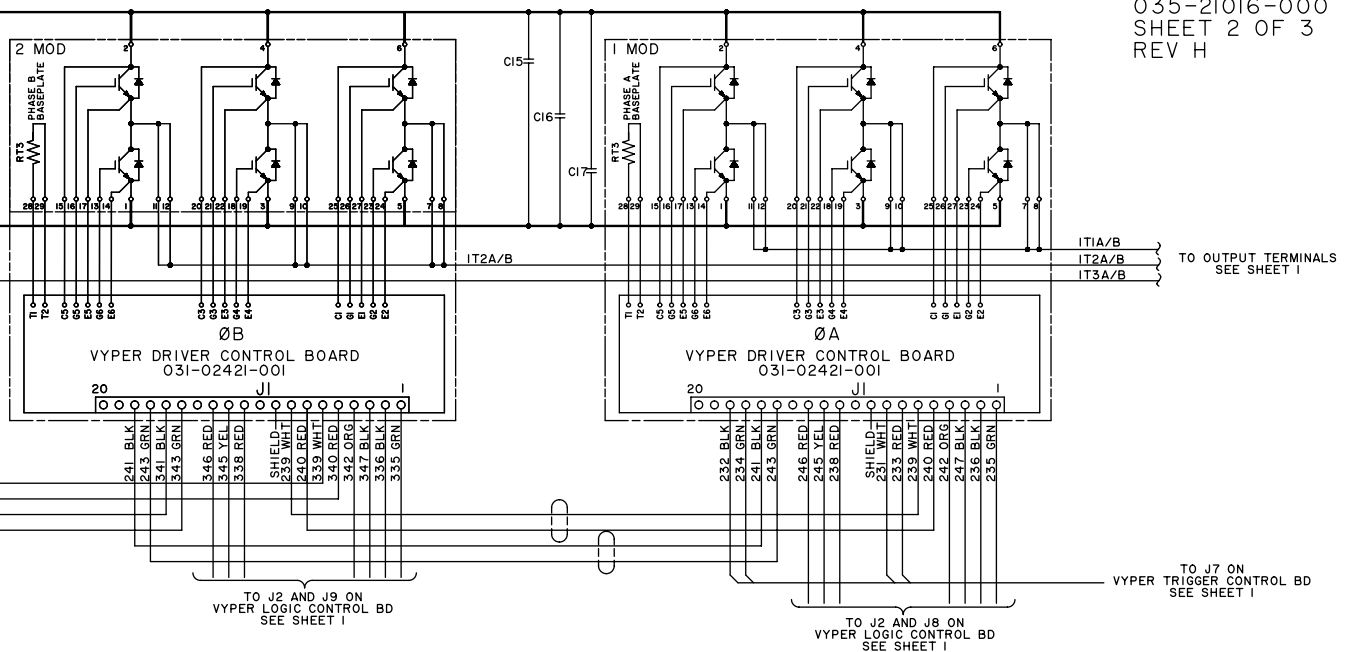
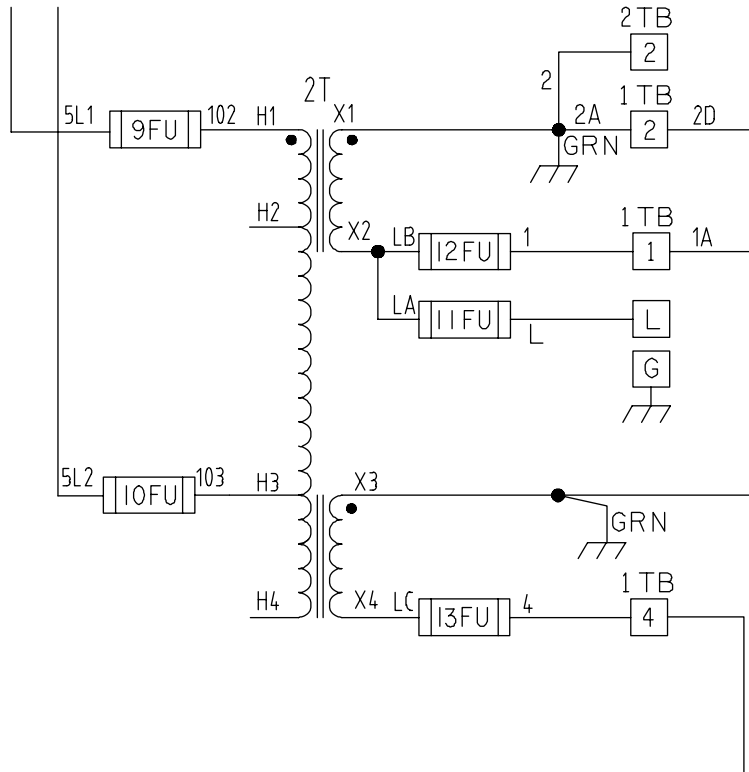
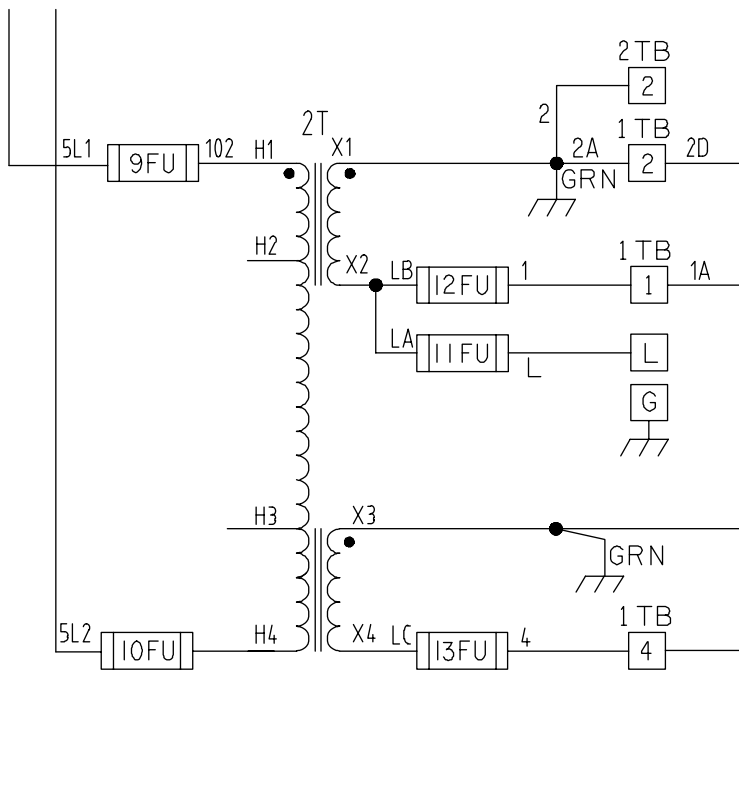

FIGURE 13 - POWER ASSEMBLY ELEMENTARY WIRING DIAGRAM 608 HP FOR VSD MODELS GLOBAL DESIGN (CONT'D)

LD19436



035W23518-000
 REV. H
 292, 419, 658 AND 900HP
 50HZ, 400VAC



035W23521-000
 REV. E
 292, 419, 704 AND 900HP
 50HZ, 415VAC

LD22789

FIGURE 14 - TRANSFORMER WIRING ASIA DESIGN

THIS PAGE INTENTIONALLY LEFT BLANK.

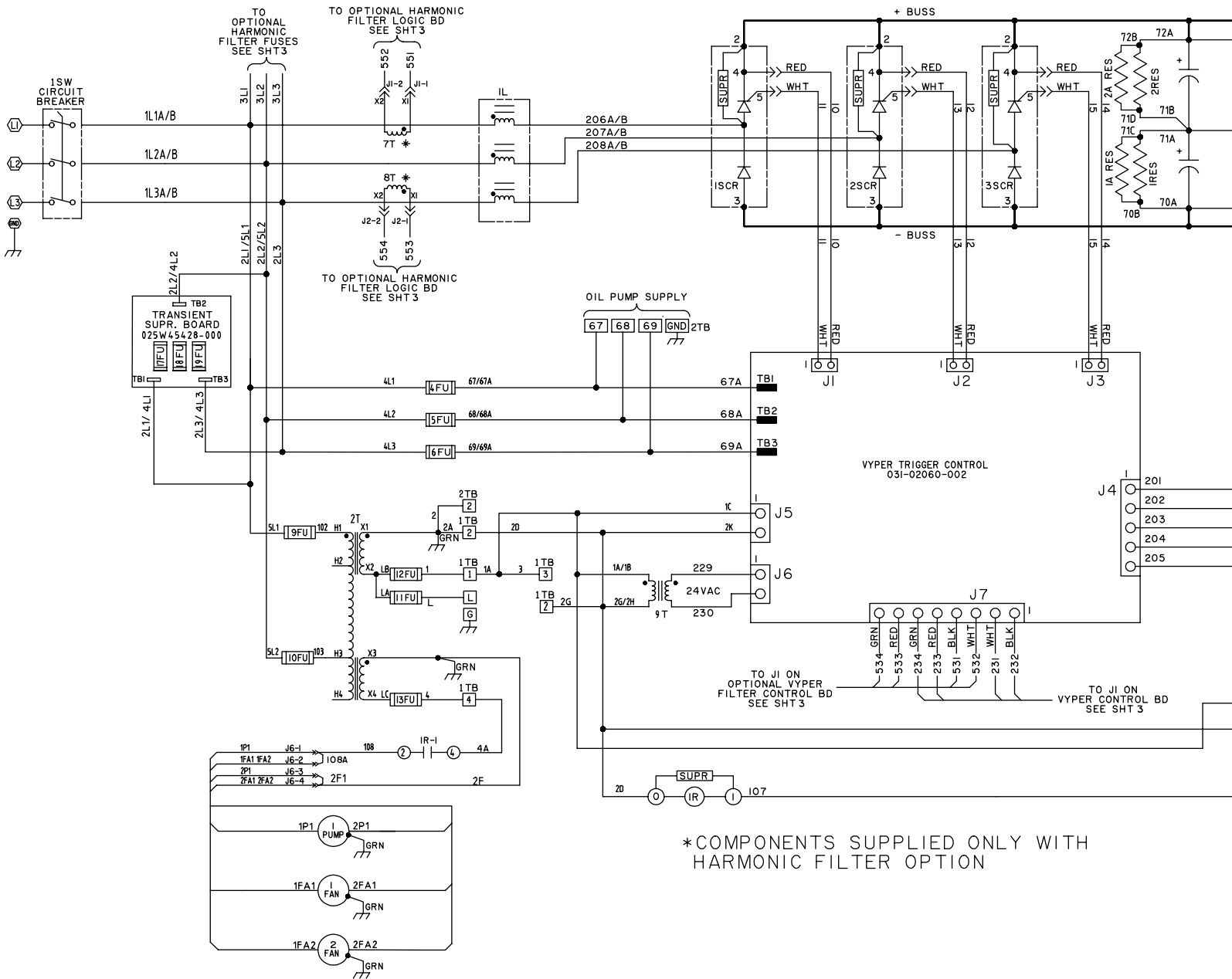

FIGURE 15 - ELEMENTARY WIRING DIAGRAM 658 AND 704 HP FOR VSD MODELS ASIA DESIGN

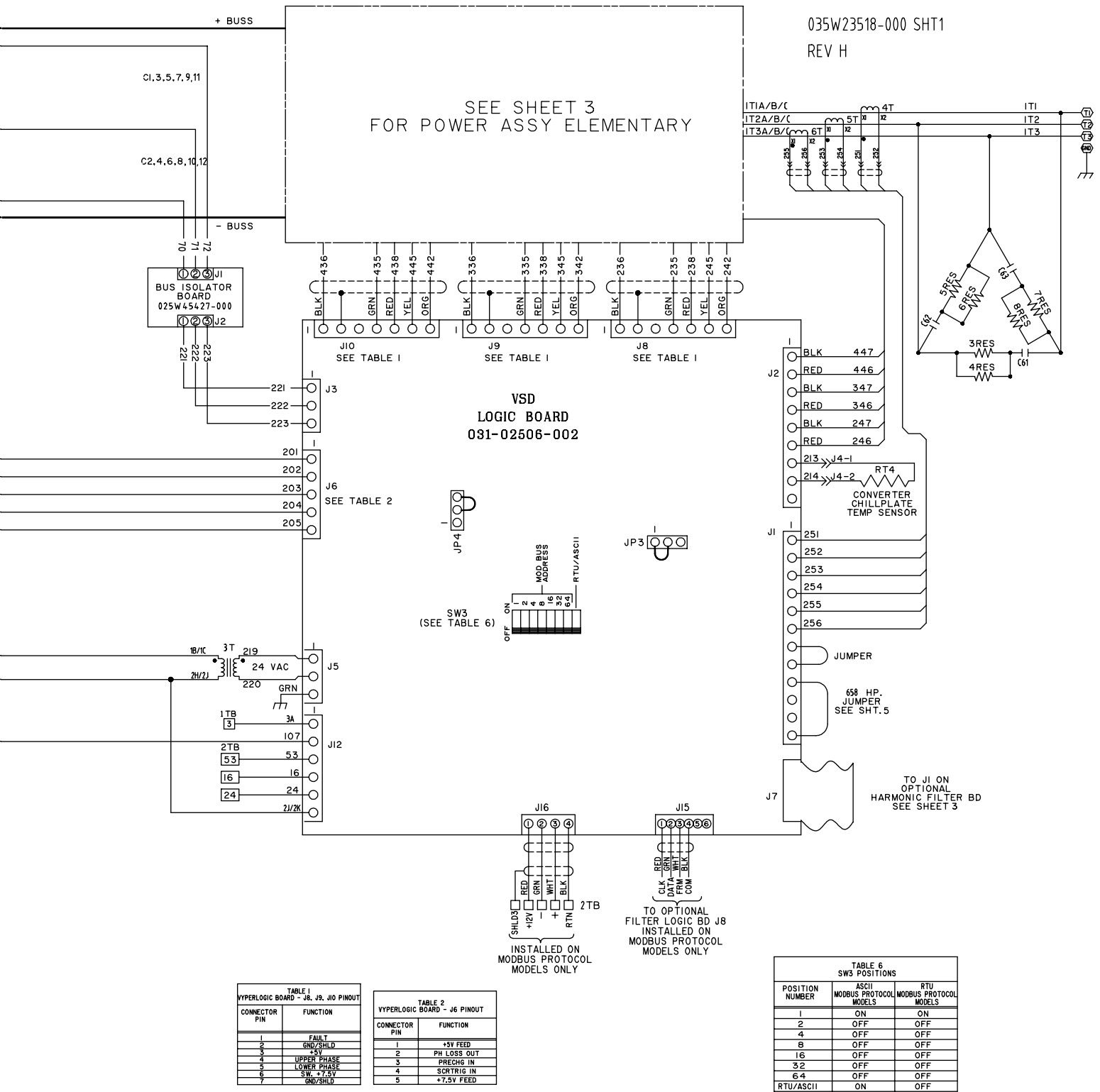
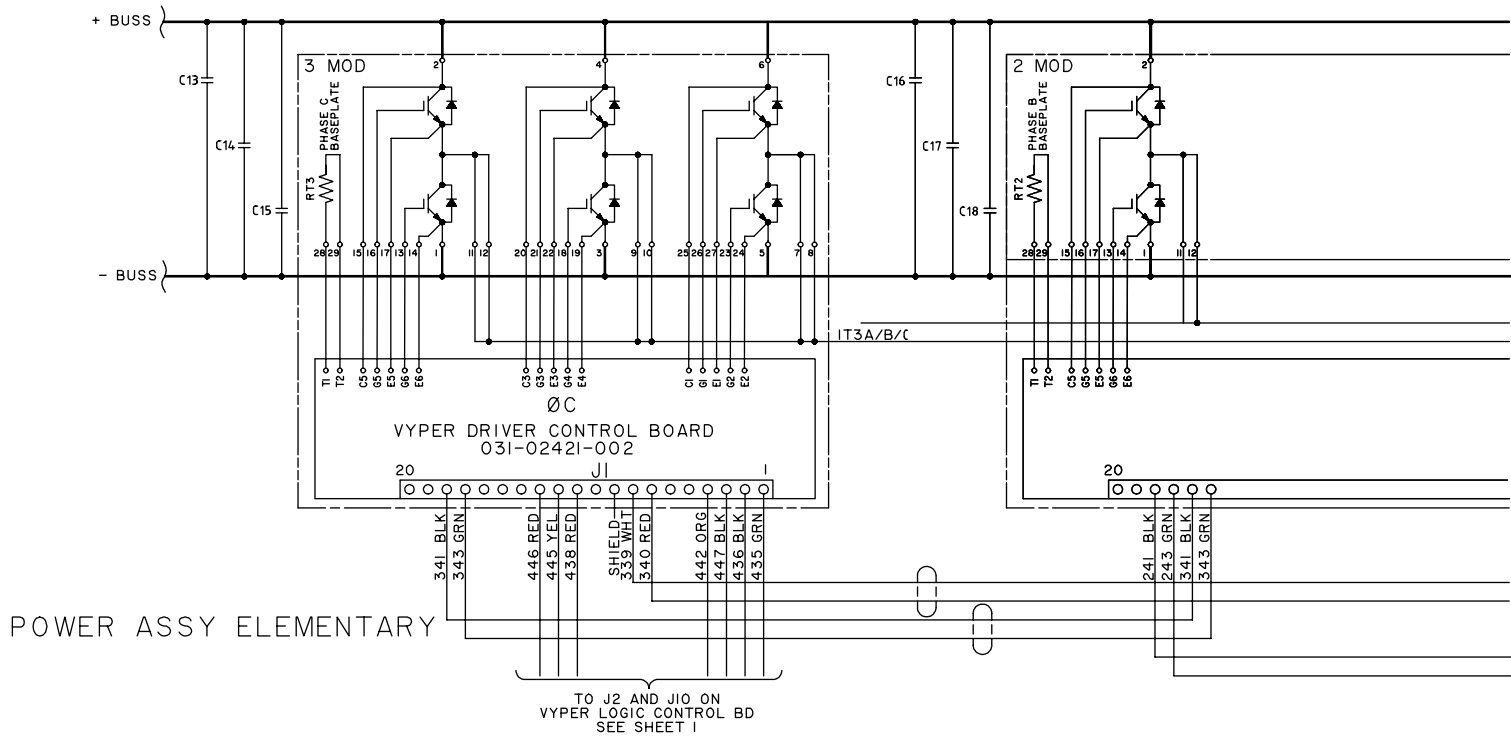
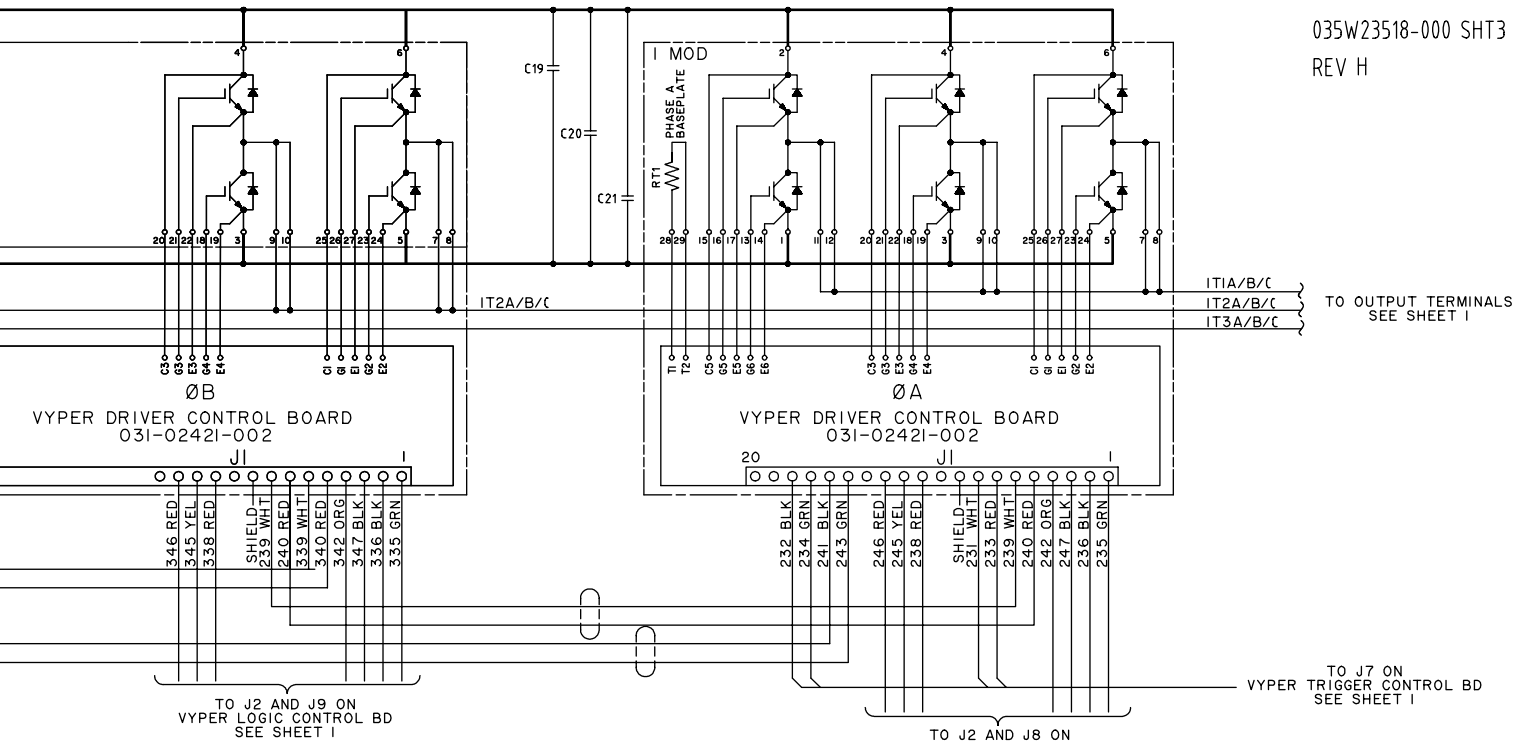

FIGURE 15 - ELEMENTARY WIRING DIAGRAM 658 AND 704 HP FOR VSD MODELS ASIA DESIGN (CONT'D)



LD19776

FIGURE 16 - POWER ASSEMBLY ELEMENTARY WIRING DIAGRAM 658 AND 704 HP FOR VSD MODELS ASIA DESIGN



LD19777

FIGURE 16 - POWER ASSEMBLY ELEMENTARY WIRING DIAGRAM 658 AND 704 HP FOR VSD MODELS ASIA DESIGN (CONT'D)

THIS PAGE INTENTIONALLY LEFT BLANK.

SECTION 2 - HARMONIC FILTER OPTION

GENERAL

The OptiSpeed Compressor Drive (OSCD) system may also include an optional harmonic filter and high frequency trap designed to meet the IEEE Std 519 -1992, "IEEE Recommended Practices and Requirements for Harmonic Control in Electrical Power Systems". The harmonic filter is offered as a means to improve the input current waveform drawn by the OSCD from the AC line, thus reducing the possibility of causing electrical interference with other sensitive electronic equipment connected to the same power source.

Figure 17 on page 45 is a typical input current waveform for the OSCD system without the optional harmonic filter when the system is operating at 50% load. *Figure 18 on page 45* is a typical input current waveform for the OSCD system with the optional harmonic filter installed when operating at the same load conditions. The waveforms show that the input current waveform is converted from a near square waveform to a fairly sinusoidal waveform when the harmonic filter is installed. In addition, the power factor of the system with the harmonic filter installed corrects the system power factor to nearly unity.

Harmonic Filter Option 270, 292, 351 and 424 Hp

The power section of the Harmonic Filter is composed of three major blocks: a pre-charge section, a three-phase inductor and a Filter Power Unit. The following description of operation is specific for the 351 Hp OSCD unless otherwise noted. (see *Figure 20 on page 48*).

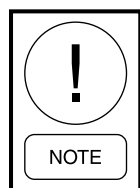

The figures for all horsepower harmonic filters are included in this form, but the component identifications are specific for the 351 horsepower drive.

The pre-charge section is formed by three resistors (9RES - 11RES), and two contactors, pre-charge contactor 1M and supply contactor 2M. The pre-charge network serves two purposes, to slowly charge the DC link filter capacitors associated with the Filter Power Unit (via the diodes within the IGBT module 2MOD) and to provide a means of disconnecting the filter power unit from the AC line. When the chiller is turned off, both contactors are de-energized and the filter power

unit is disconnected from the AC line. When the chiller starts to run, the pre-charge resistors are switched into the circuit via contactor 1M for a fixed time period of 5 seconds. This permits the filter capacitors in the filter power unit to slowly charge. After the 5-second time period, the supply contactor is energized, and the pre-charge contactor is de-energized, permitting the filter power unit to completely charge to the peak of the input power voltage. Three power fuses (8FU - 10FU) connect the filter power components to the AC line. Very fast semiconductor power fuses are utilized to ensure that the IGBT module does not rupture if a catastrophic failure were to occur on the DC link of the filter power unit.

The three phase inductor (2L) provides some impedance for the filter to "work against". It effectively limits the rate of change in current at the input to the filter to a reasonable level.

The Filter Power Unit is the most complicated power component in the optional filter. Its purpose is to generate the harmonic currents required by the OSCD's AC-to-DC converter so that these harmonic currents are not drawn from the AC line. The Filter Power Unit is identical to the OSCD's Power Unit in the 351 Hp drive, except for 2 less capacitors in the filter capacitor "bank" (C13-C16), a smaller IGBT module (2MOD) mounted to a direct liquid cooled heatsink, and a Harmonic Filter Gate Driver board (031-02061-002).

The Harmonic Filter Gate Driver board provides turn on, and turn off commands to the IGBT module as determined by the Harmonic Filter Logic board. In order to assure an equal sharing of the voltage between the series connected capacitors on the Filter Power Unit, "bleeder" resistors 12RES and 13RES are connected across the cap bank. The "Bleeder" resistors are mounted on the side of the Filter Power Unit to provide a discharge path for the DC Link filter capacitors. In order to counteract the parasitic inductances in the mechanical structure of the Filter Power Unit, the filter incorporates "laminated bus" technology and a series of small film capacitors (C23-C25). The "laminated bus" technology used is identical to that used in the OSCD's DC to AC inverter section of the drive.

Other sensors and boards are used to convey information back to the Filter Logic Board, and provide safe operation of the harmonic filter. The IGBT module contains a thermistor temperature sensor (RT3) that provides temperature information back to the Filter Logic Board via the Harmonic Filter Gate Driver Board. This sensor protects the Filter IGBT module from over temperature conditions. DC Current Transformers DCCT1

and DCCT2 sense the current generated by the optional filter. These two sensors are used to protect against a filter over current, or a filter overload condition. Current Transformers 6T and 7T sense the input current drawn by the OSCD's AC to DC converter. These two CT's are no longer present in the standard OSCD.

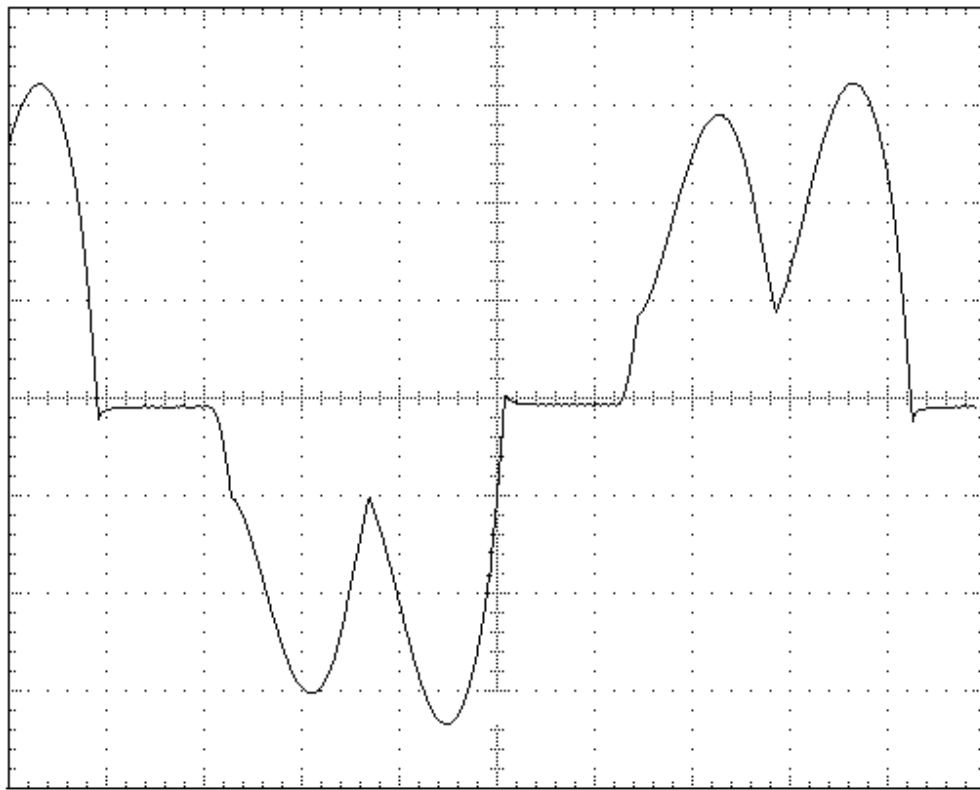

LD07407

FIGURE 17 - VSD INPUT CURRENT WITHOUT FILTER

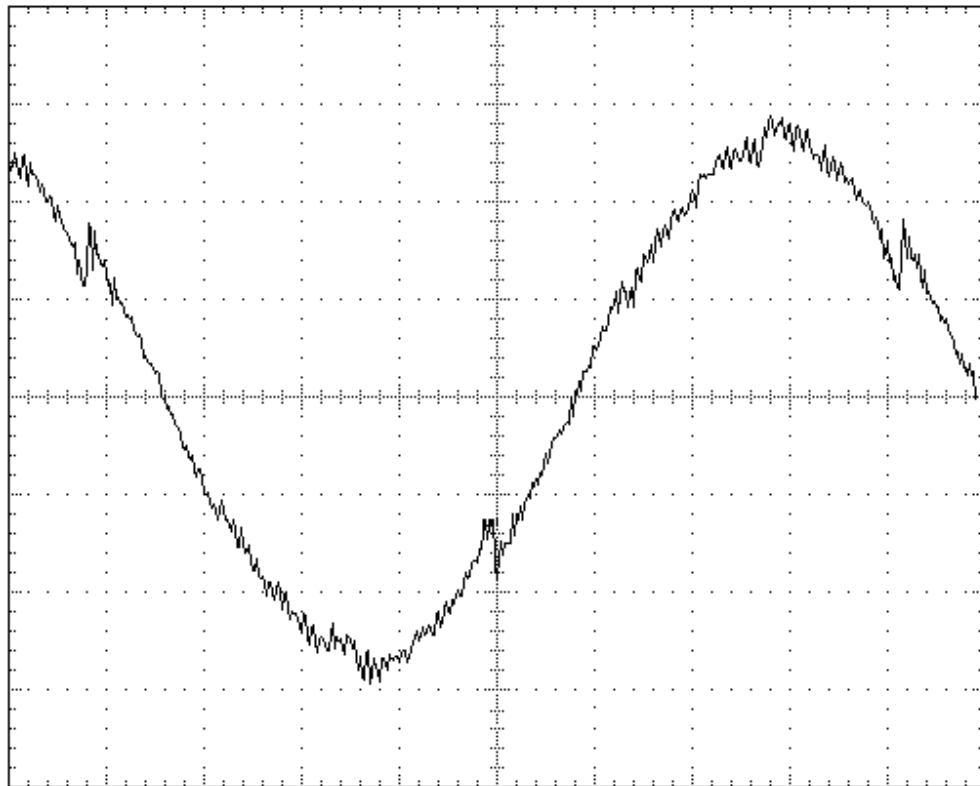

LD07408

FIGURE 18 - VSD INPUT CURRENT WITH FILTER

Harmonic Filter Logic Board History

The Harmonic Filter logic board had many changes due to microprocessors become obsolete. The function of the filter logic board remain the same for many years. The original part number of the filter logic board was 031-01632-xxx. There are many line numbers for the filter logic board. When there is a change in the drive's input current transformer ratio, there must a new line number for the filter logic board. Refer to the part manual for more details about part numbers (160.00-RP4). Early revisions of the filter logic board contained only 6 connection on the J5 connector. Later revisions were not compatible with the earlier designs and required a service kit when replacing the filter logic board. To prevent the 2 different designs from become mixed in the field the connections on the J5 connector were increased to 8. The board part number remained the same, but the revision level increased to 'R'. The current design maintains the existing function, but added a feature that allows the gate drivers for the Harmonic Filter to be tested in the same manner as the drive's gate drivers. The part number of the new Harmonic Filter Logic board is 031-02932-xxx. The main filter logic board software is backwards compatible (U42). To improve noise immunity of the filter logic board a ground wire was added to the board. If a replacement 031-02932 board is being installed, the ground will need to be connected where the shields are connected for the cable used for J2 and J8. The filter logic board will not function with the ground wire not connected.

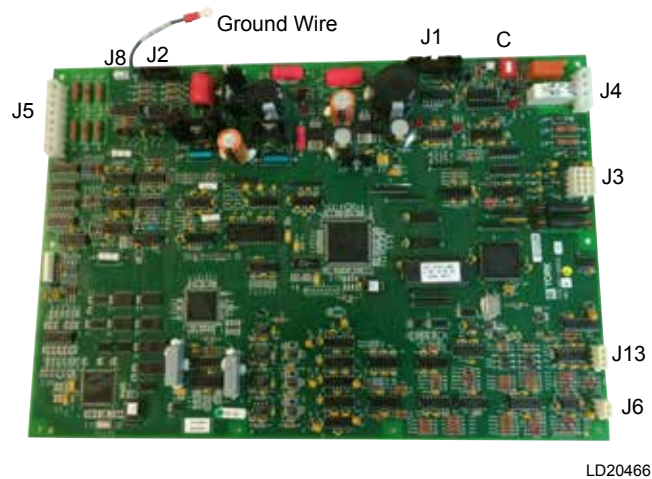
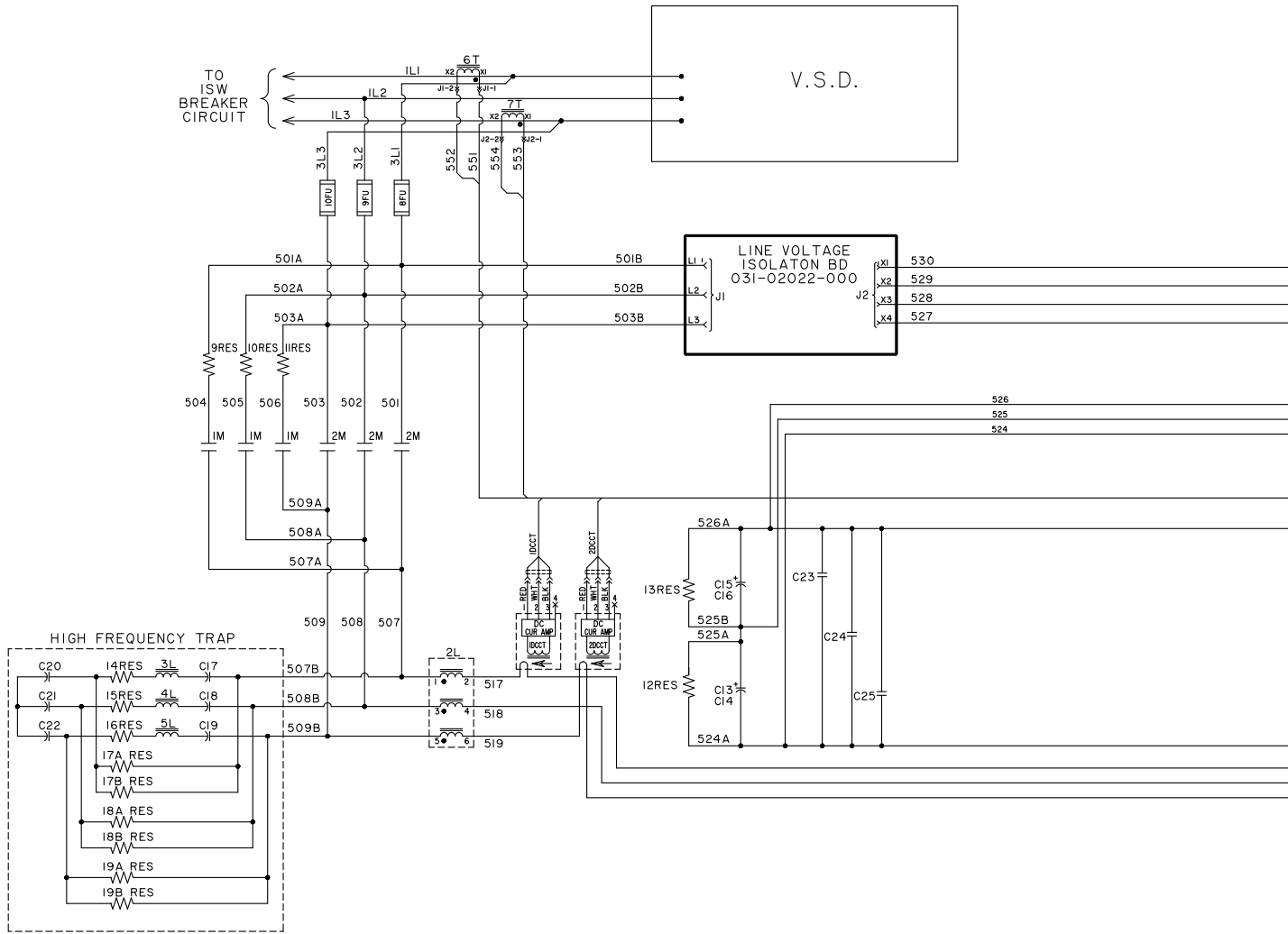

FIGURE 19 - VSD MODEL HARMONIC FILTER LOGIC BOARD 031-02932-XXX

- J1: Drive Logic Board Interface
- J2: A, B and C Phase Gate Driver Interface
- J3: Current Feedback From Input and Output Current Sensors
- J4: Harmonic Filter Pre-Charge and Supply Contactors Control wiring
- J5: Input AC Line Voltage and DC bus Voltage Detection
- J6: IGBT Baseplate Temperature Connection
- J8: Communications Link to the Drive Logic Board
- J13: IGBT Baseplate Temperature Connection when more than one baseplate is used.
- A: Main Microprocessor Software U42
- B: Software for PWM Microprocessor U112
- C: SW1 Enable or Disable Harmonic Filter Function.

THIS PAGE INTENTIONALLY LEFT BLANK.

HARMONIC FILTER WIRING DIAGRAMS



LD13110a

FIGURE 20 - HARMONIC FILTER ELEMENTARY WIRING DIAGRAM 270, 292 AND 351 HP FOR VSD MODELS GLOBAL DESIGN MANUFACTURED AFTER DECEMBER 2006

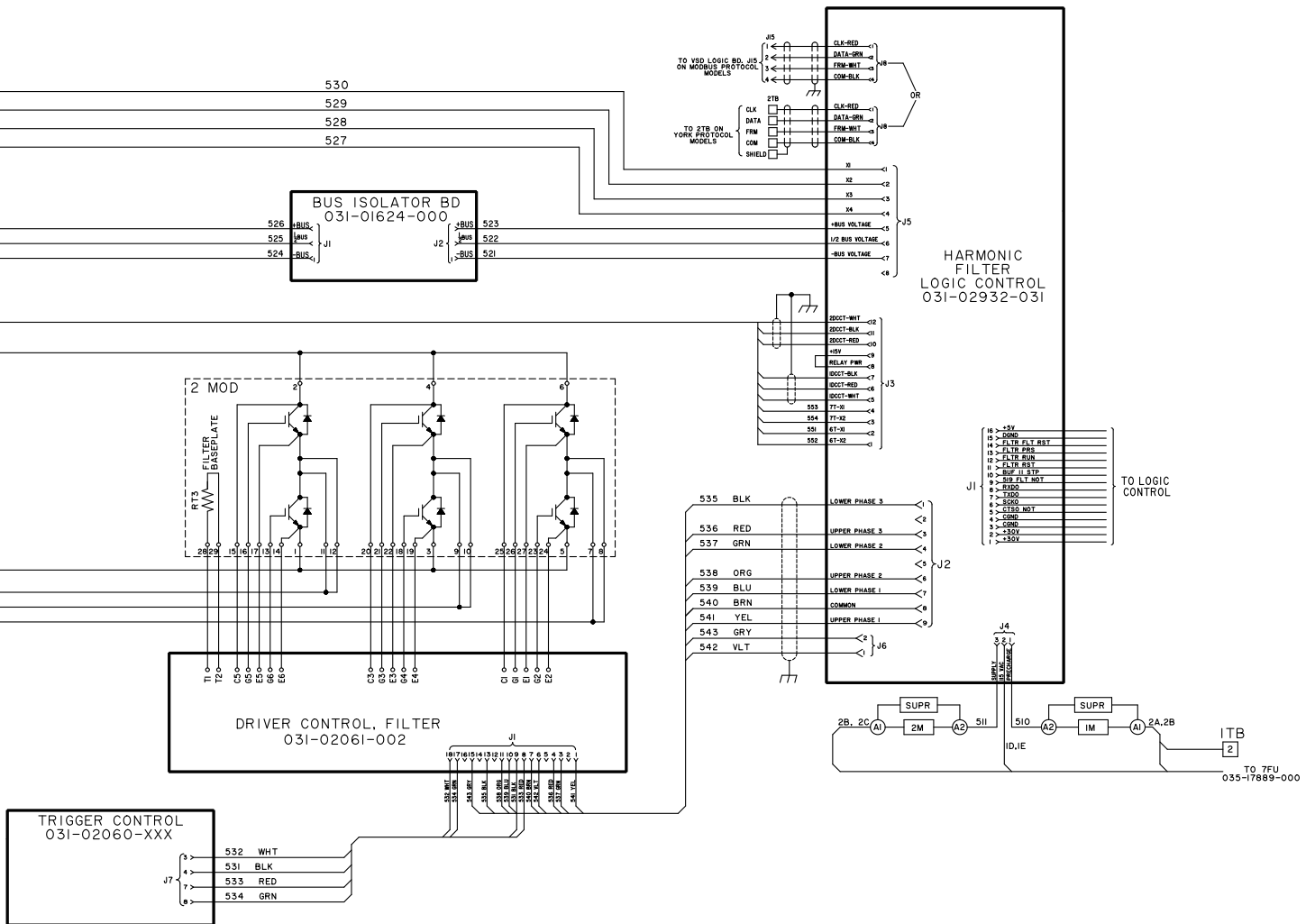
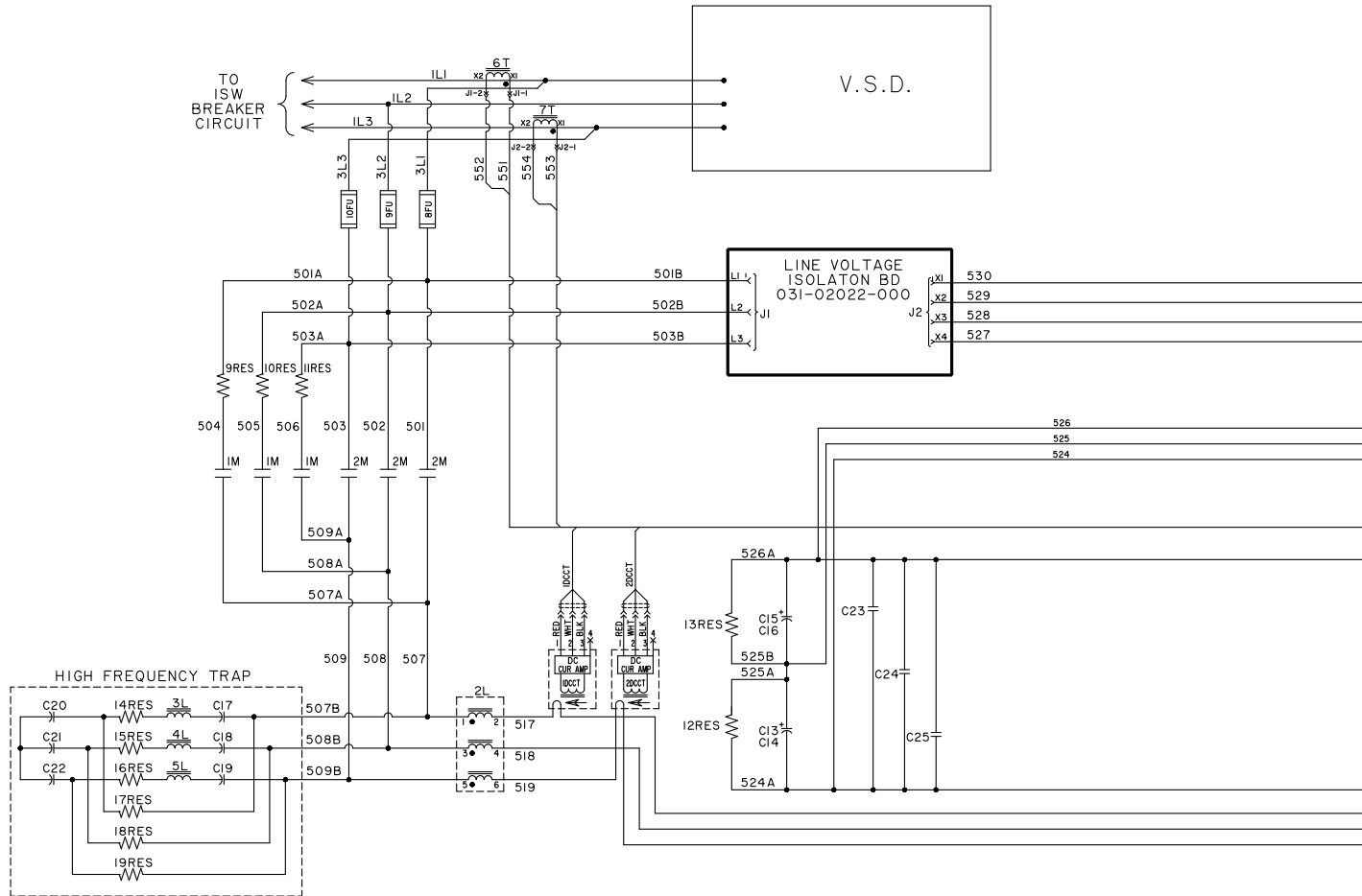

FIGURE 20 - HARMONIC FILTER ELEMENTARY WIRING DIAGRAM 270, 292 AND 351 HP FOR VSD MODELS GLOBAL DESIGN MANUFACTURED AFTER DECEMBER 2006 (CONT'D)

LD13111a



LD13110b

FIGURE 21 - HARMONIC FILTER ELEMENTARY WIRING DIAGRAM 270, 292 AND 351 HP FOR VSD MODELS GLOBAL DESIGN MANUFACTURED BEFORE DECEMBER 2006

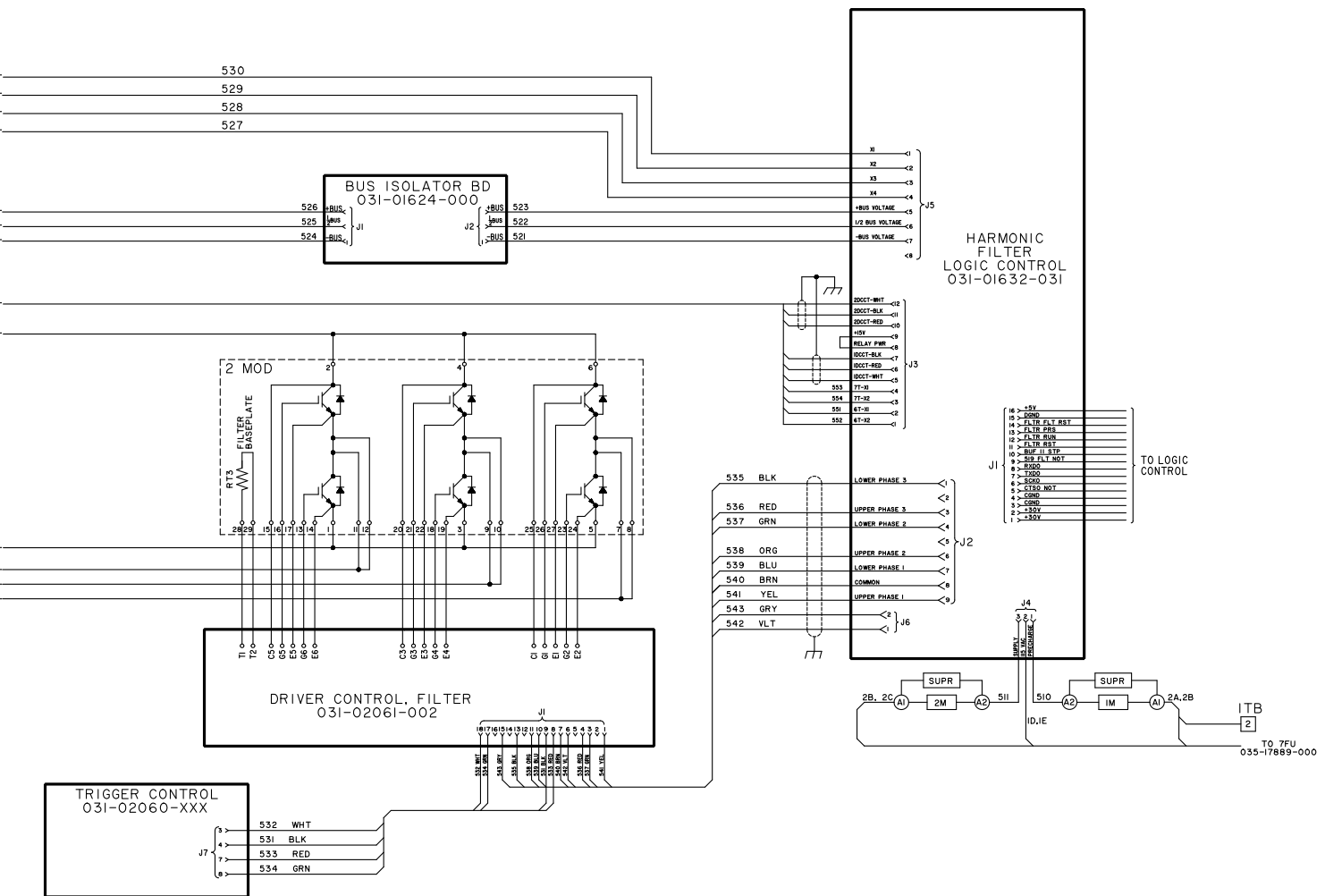
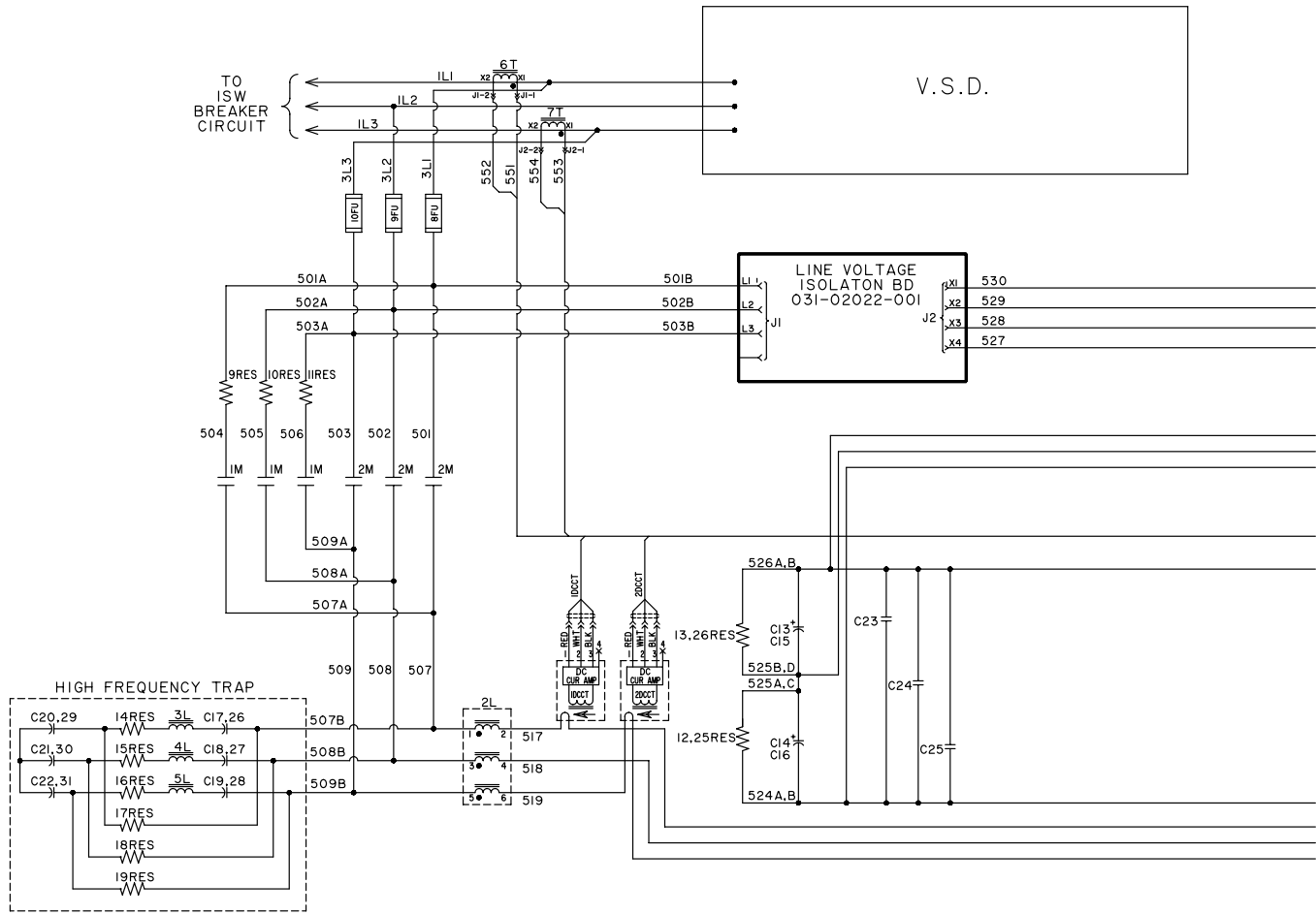

FIGURE 21- HARMONIC FILTER ELEMENTARY WIRING DIAGRAM 270, 292 AND 351 HP FOR VSD MODELS GLOBAL DESIGN MANUFACTURED BEFORE DECEMBER 2006 (CONT'D)

LD13111b



LD19439

FIGURE 22 - HARMONIC FILTER ELEMENTARY WIRING DIAGRAM 424 HP FOR VSD MODELS GLOBAL DESIGN MANUFACTURED AFTER DECEMBER 2006

035-21024-000
 REV. D

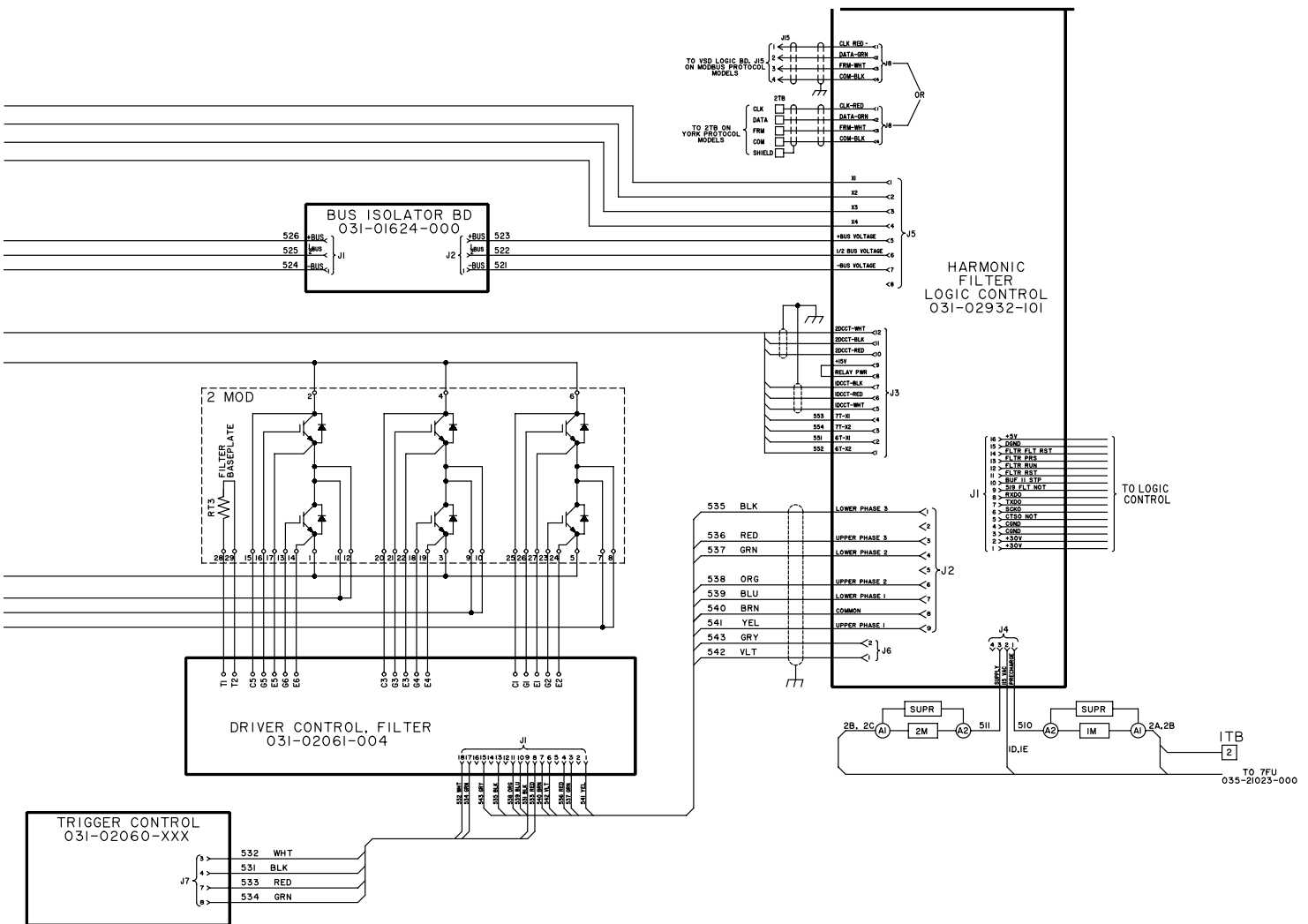

LD19440

FIGURE 22 - HARMONIC FILTER ELEMENTARY WIRING DIAGRAM 424 HP FOR VSD MODELS GLOBAL DESIGN MANUFACTURED AFTER DECEMBER 2006 (CONT'D)

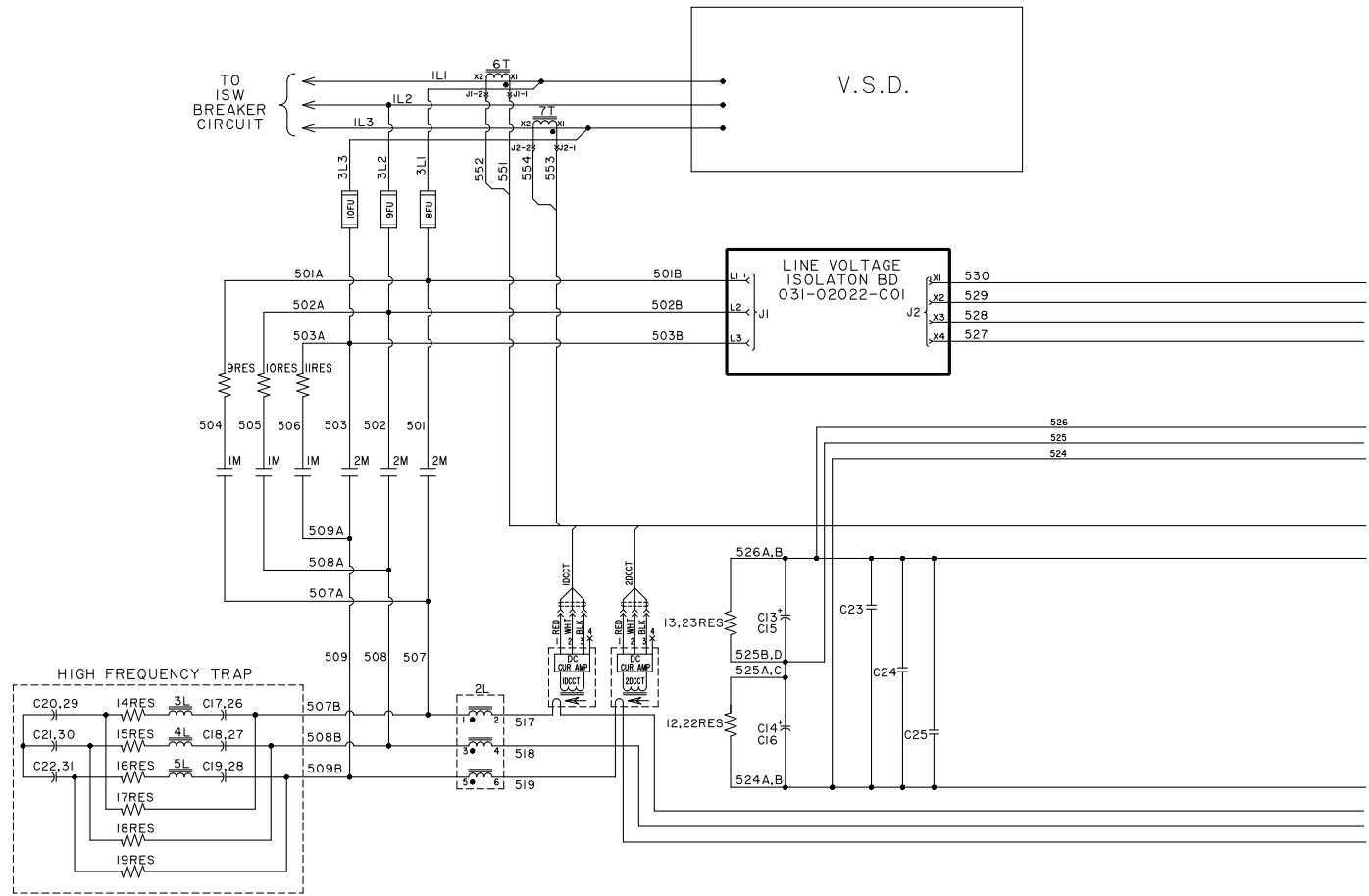

LD13112b

**FIGURE 23 - HARMONIC FILTER ELEMENTARY WIRING DIAGRAM 424 HP FOR VSD
MODELS GLOBAL DESIGN MANUFACTURED BEFORE DECEMBER 2006**

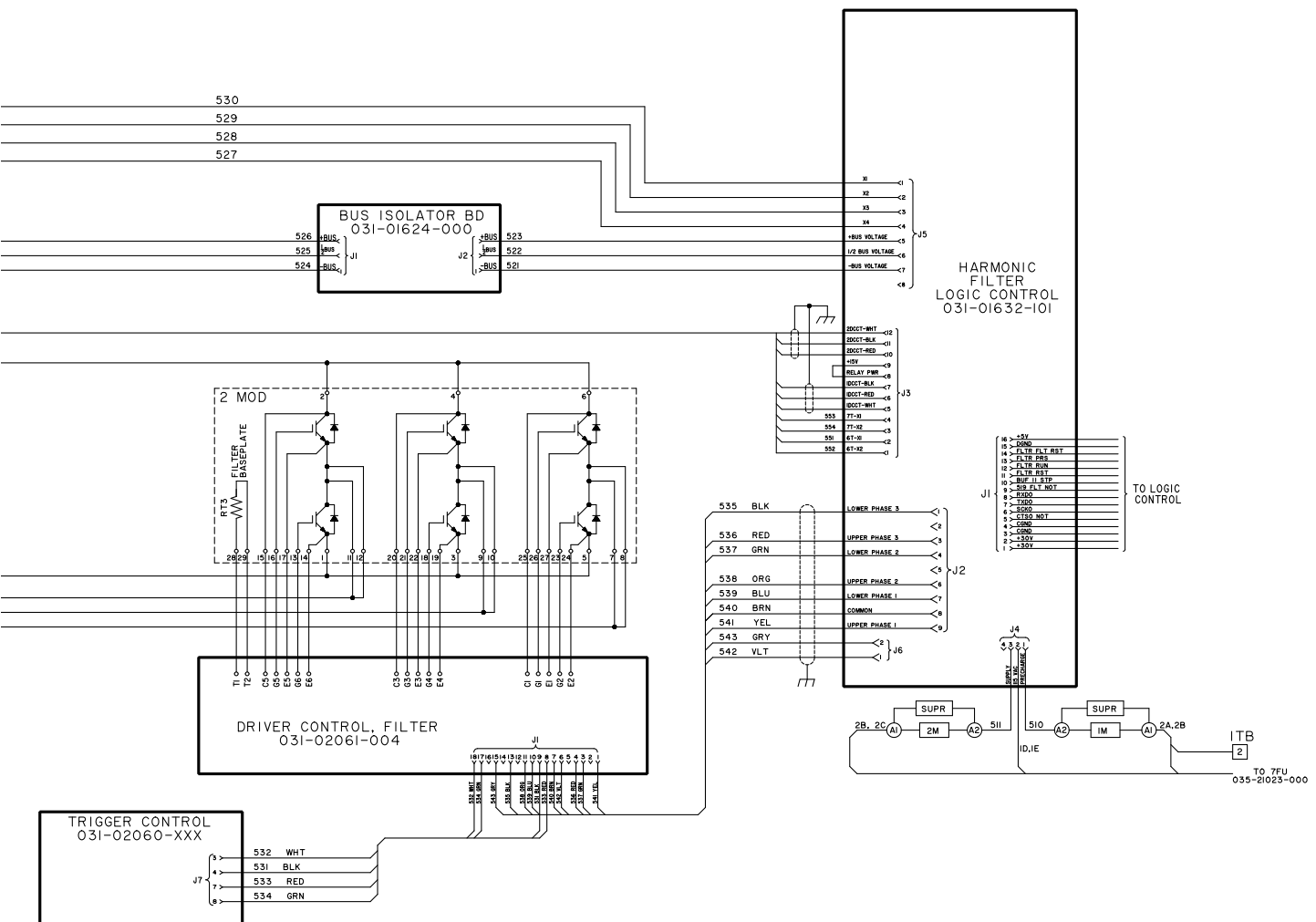

FIGURE 23 - HARMONIC FILTER ELEMENTARY WIRING DIAGRAM 424 HP FOR VSD MODELS GLOBAL DESIGN MANUFACTURED BEFORE DECEMBER 2006 (CONT'D)

LD13113b

The Line Voltage Isolation board (031-02022-000 400 and 460 VAC input, 031-02022-001 575 VAC input) provides AC line voltage information. This board steps the line voltage down to a safe level and provides isolation to the Filter Logic board. This information is used to determine a phase rotation, voltage zero crossing time, and what the proper bus voltage should be. The Bus Isolation board (031-01624) incorporates three resistors to provide a “safe” impedance between the DC filter capacitors located in the Filter Power Unit and the Filter Logic Board. It provides the means to sense the positive, midpoint and negative connection points of the filter’s DC link. This information is used to determine bus voltage imbalance, high bus voltage, and low bus voltage shut downs.

The “trap” filter is standard on all OSCD that contain the optional Harmonic Filter. The “trap” filter is composed of a series of capacitors (C17-C22), inductors (3L-5L) and resistors (14RES-19RES). The “trap” filter acts as a low resistance for a range of frequencies centered at the switching frequency of the filter. The purpose of the trap is to block currents at the switching frequency of the harmonic filter from getting onto the power mains.

Harmonic Filter Option 385, 419, 503 and 608 HP

The 385, 419, 503 and 608 Hp harmonic filter functions in the same manner as the 351 Hp and have the many of the same components, but more of them. The

power requirements of these higher horse power drives require more capacitors in the DC Link, and a higher current rated IGBT module is needed. The IGBT module contains a thermistor, and it is connected to the harmonic filter logic board. The IGBT gate driver board is mounted on top of the IBGT module as in the 351 Hp. The modules and the boards are not interchangeable between the different horsepower drives.

575 VAC Harmonic Filter Differences From 460 VAC Harmonic Filter

The 424 and 608 Horsepower harmonic filters are 575 VAC versions of the 460 VAC 351 and 503 Hp harmonic filters. A few changes to the OSCD are required.

First, the input IGBT’s voltage rating is increased as well as the voltage rating for the Bus caps. The harmonic filter logic is change to accommodate the higher bus voltage and changes in carrier frequency. The trap assembly has changed because of the changes in the carrier frequency for the harmonic filter. More bleeder resistors of a higher resistance value are required to support the higher bus voltage.

Wiring Field Connections (Variable Speed Drive) Replacement Parts List (Variable Speed Drive) (Form 160.00-RP4) contains all of the different part number required for these products. **It is very important not to mix parts between different voltage ranged OSCD.**

THIS PAGE INTENTIONALLY LEFT BLANK.

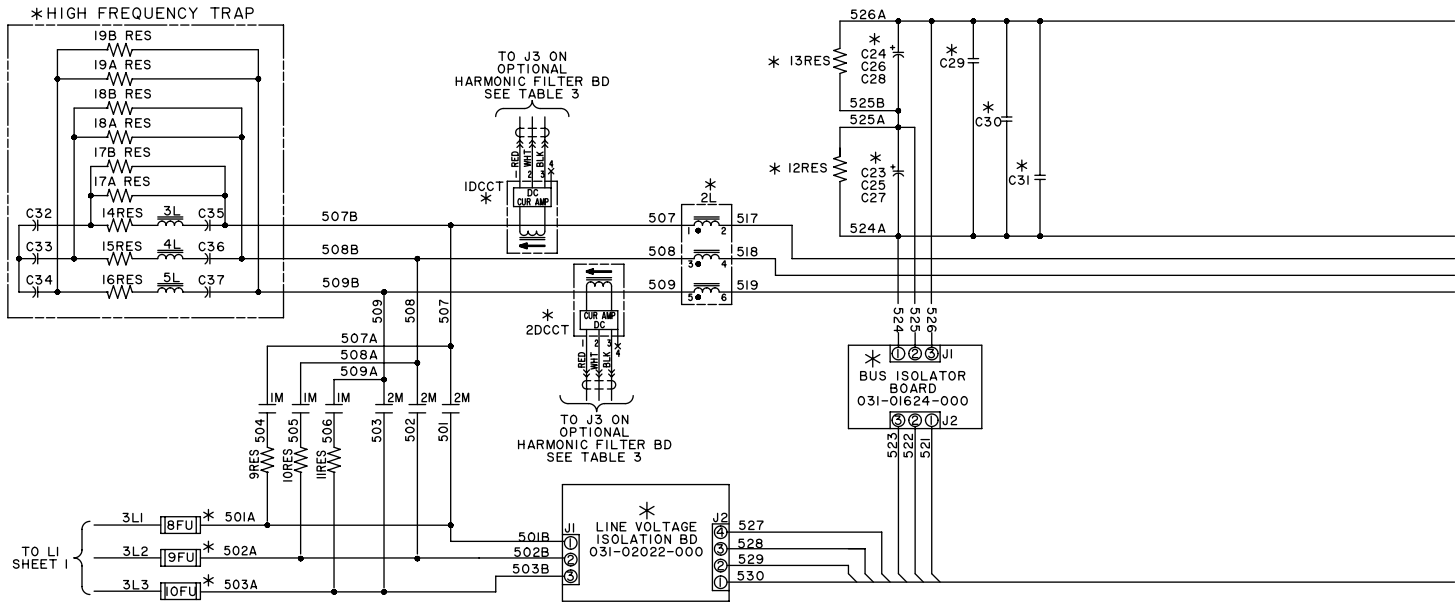

*COMPONENTS SUPPLIED ONLY WITH HARMONIC FILTER OPTION

LD19441

FIGURE 24 - HARMONIC FILTER WIRING DIAGRAM 385, 419 AND 503 HP FOR VSD MODELS GLOBAL DESIGN AFTER DECEMBER 2006

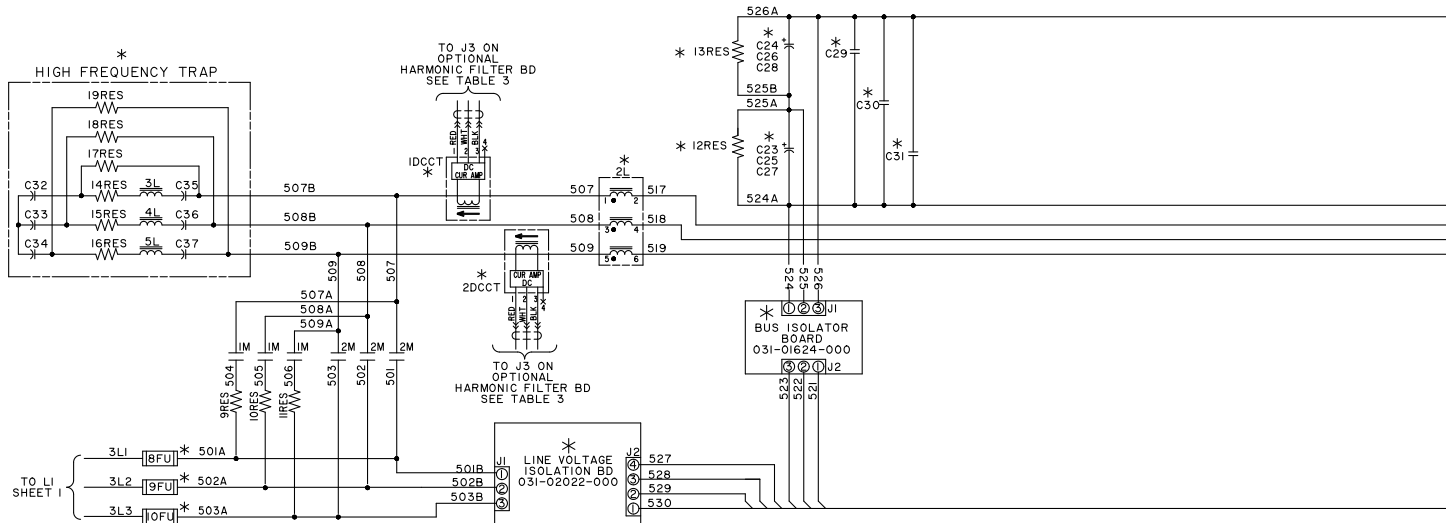

LD13116b

FIGURE 25 - HARMONIC FILTER WIRING DIAGRAM 385, 419 AND 503 HP FOR VSD MODELS GLOBAL DESIGN BEFORE DECEMBER 2006

035-18685 SHT 2
REV E

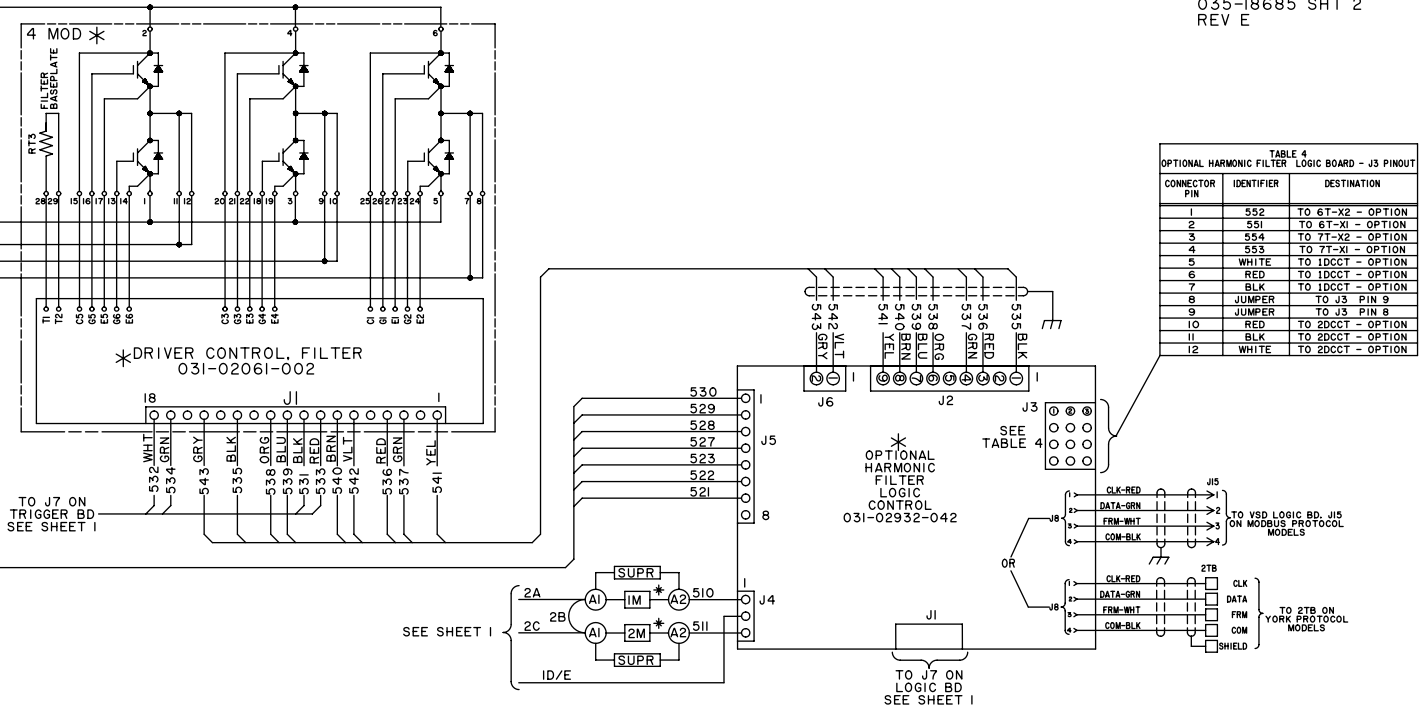

FIGURE 24 - HARMONIC FILTER WIRING DIAGRAM 385, 419 AND 503 HP FOR VSD MODELS GLOBAL DESIGN AFTER DECEMBER 2006 (CONT'D)

LD19442

035-18685 SHT 2
REV B

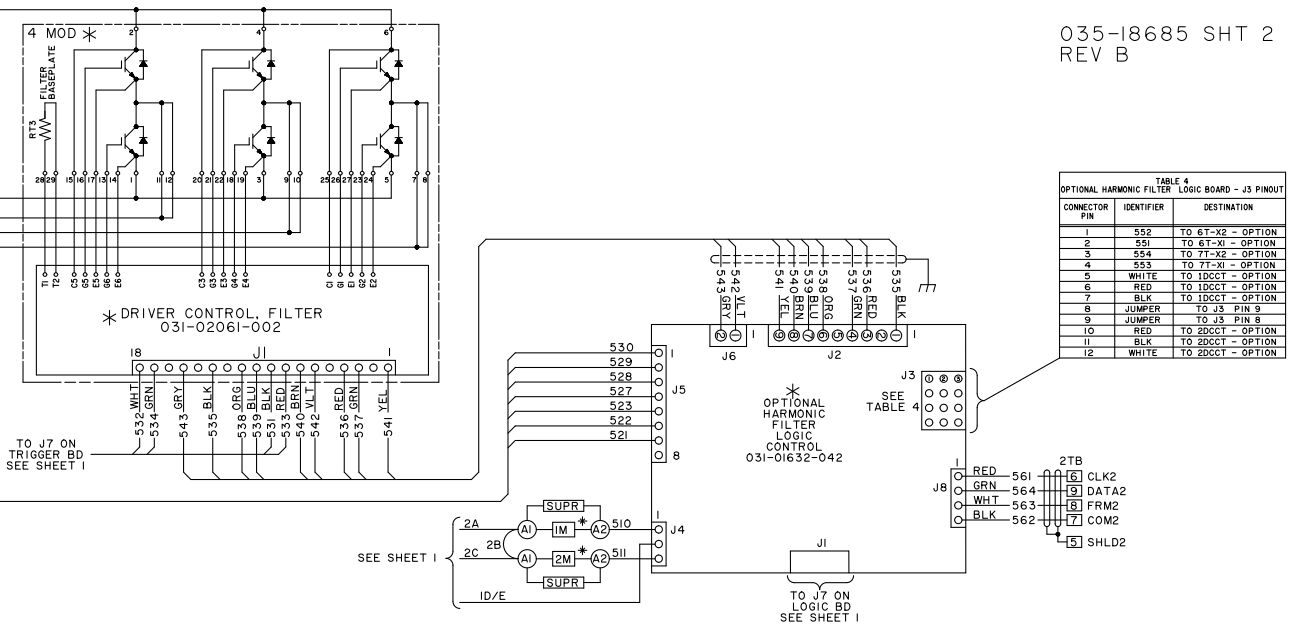

FIGURE 25 - HARMONIC FILTER WIRING DIAGRAM 385, 419 AND 503 HP FOR VSD MODELS GLOBAL DESIGN BEFORE DECEMBER 2006 (CONT'D)

LD13117b

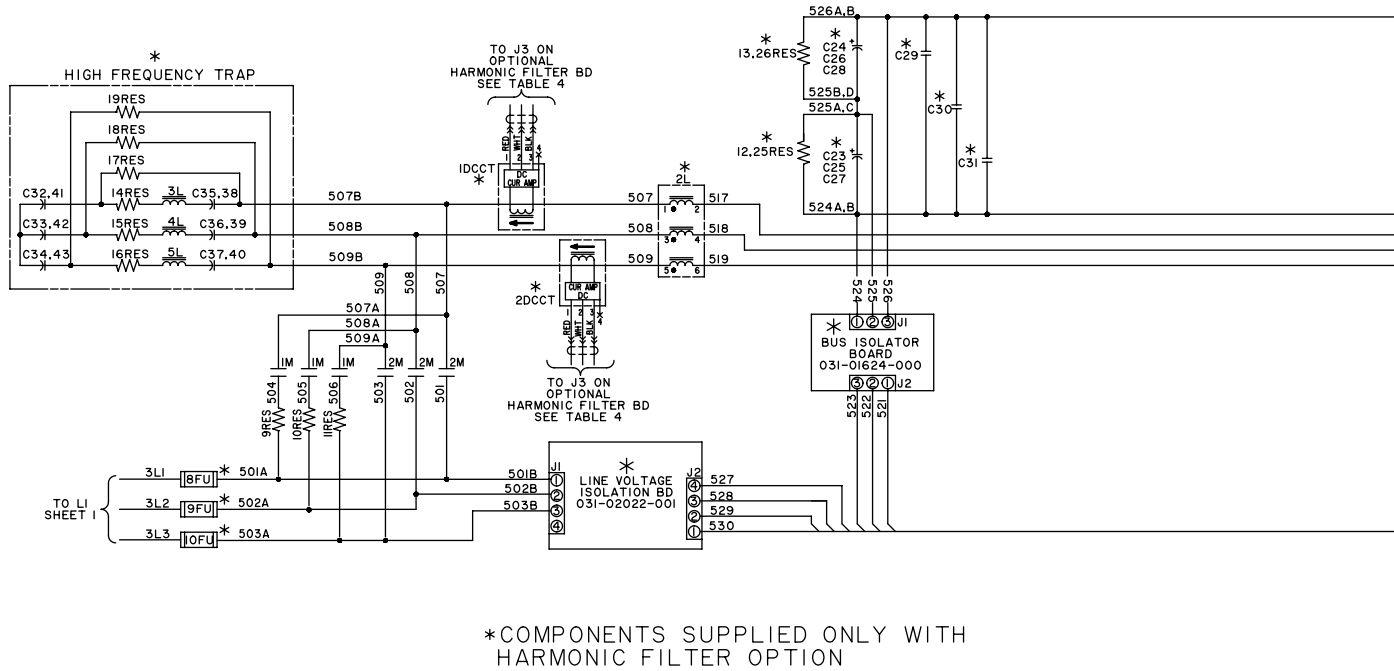

FIGURE 26 - HARMONIC FILTER WIRING DIAGRAM 608 HP FOR VSD MODELS GLOBAL DESIGN AFTER DECEMBER 2006

LD19443

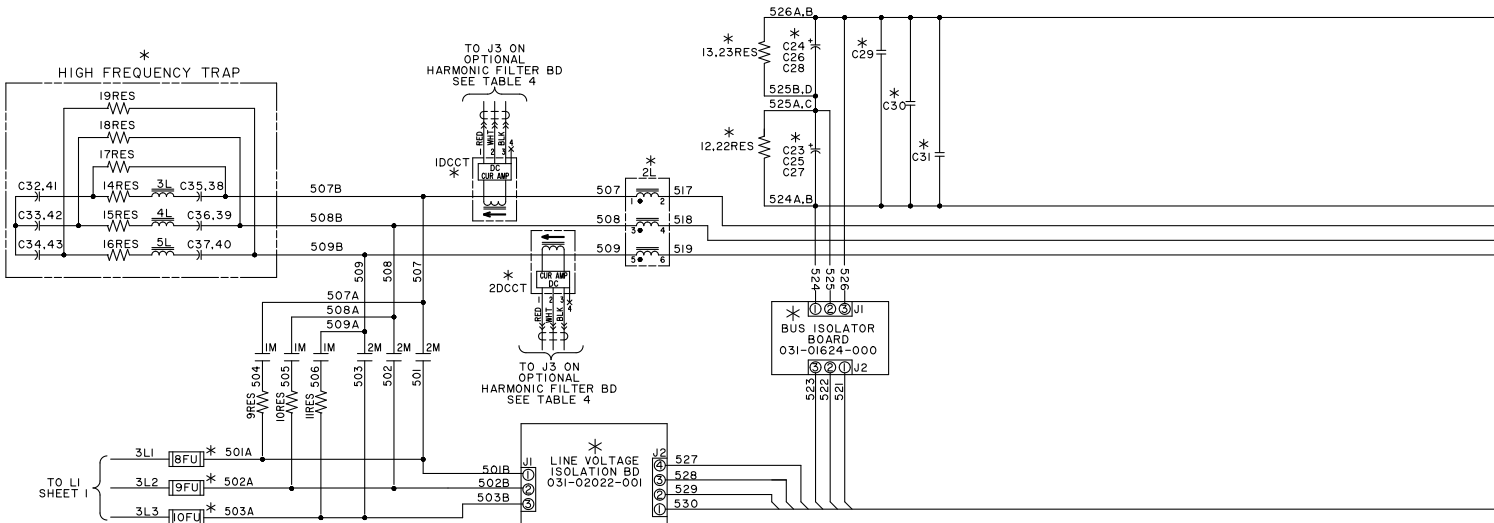
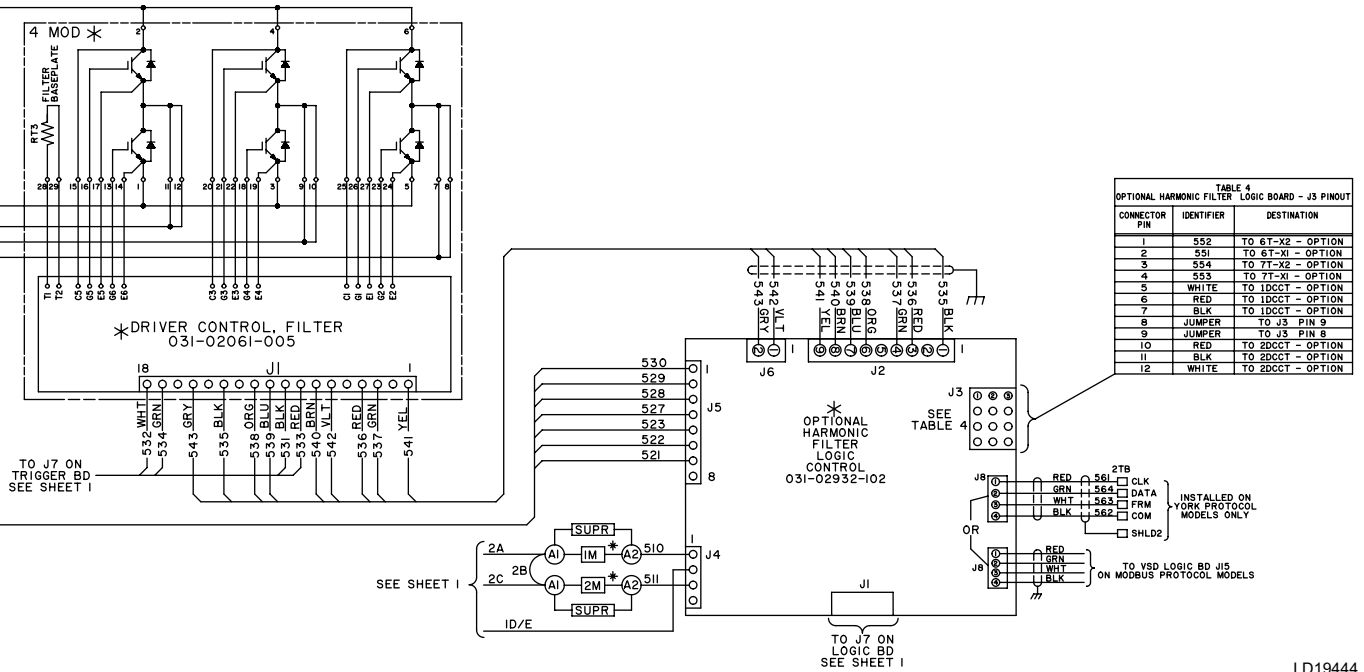

FIGURE 27 - HARMONIC FILTER WIRING DIAGRAM 608 HP FOR VSD MODELS GLOBAL DESIGN BEFORE DECEMBER 2006

LD13115b

035-21016-000
SHEET 2 OF 3
REV H

2



LD19444

FIGURE 26 - HARMONIC FILTER WIRING DIAGRAM 608 HP FOR VSD MODELS GLOBAL DESIGN AFTER DECEMBER 2006 (CONT'D)

035-21016 SHT 2
REV B

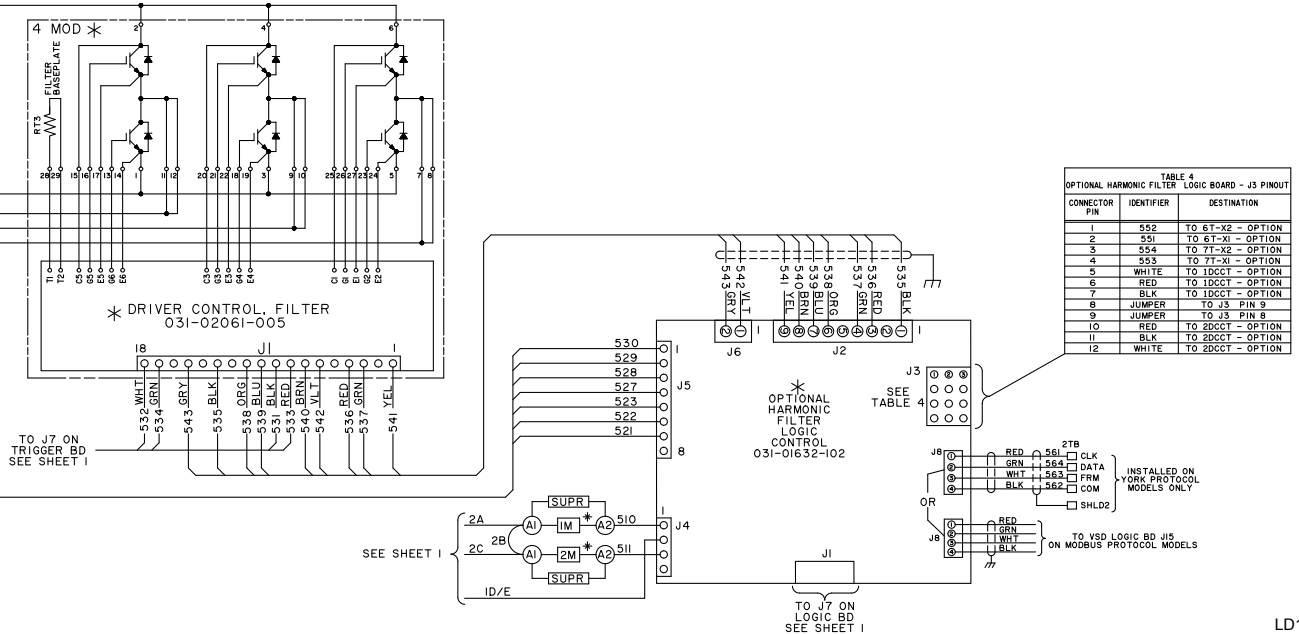

LD13114b

FIGURE 27 - HARMONIC FILTER WIRING DIAGRAM 608 HP FOR VSD MODELS GLOBAL DESIGN BEFORE DECEMBER 2006 (CONT'D)

THIS PAGE INTENTIONALLY LEFT BLANK.

SECTION 3 - LVD MODEL WIRING DIAGRAMS

NOTES / LEGEND

Notes:

1. Field wiring to be in accordance with the national electrical code as well as all other applicable codes and specifications.
2. Terminal board connection points are indicated by numbers within a square, that is, 1 2TB main power connection points are indicated by numbers within a hexagon, that is, 1 component terminal markings are indicated by numbers within a circle, that is, 2 numbers adjacent to circuit lines are the circuit identification numbers.
3. Terminals L1, L2, L3 and GRD are the main power input terminals and are field connected. (See Note 6). Terminals T1, T2 & T3 are the compressor motor lead power terminals and are factory connected on factory packaged units.
4. The three phase solid state motor overload protection system provides motor overcurrent protection at 105% full load amps.
5. See York control center wiring diagram product drawing forms *160.48-PA21* or *160.52-PW3*.
6. Field wiring connections per product drawing forms *160.48-PA15* or *160.48-PW12*.

LABEL	DESCRIPTION
C1-C8	CAPACITORS, ALUMINUM ELECTROLYTIC, 12,000 μ F, 450 VDC
C9-C17	CAPACITORS, FILM, I.O μ F, 1200 VDC
C18-C20	CAPACITORS, FILM, 0.047 μ F, 560 VAC
1FU-3FU	VYPER TRIGGER/OIL PUMP SUPPLY FUSES 7A, 600V
4FU-5FU	CONTROL SUPPLY TRANSFORMER FUSES, 15A, 600V
6FU	EXTERNAL CONTROL SUPPLY TRANSFORMER SECONDARY FUSE, 20A, 600V
7FU	INTERNAL CONTROL SUPPLY TRANSFORMER SECONDARY FUSE, 10A, 600V
IL	VSD AC INDUCTOR, 80 μ H PER PHASE, 575A
1MOD - 3MOD	IGBT MODULE, 3 PHASE. 225A, 1200V
1RES- 2RES	RESISTORS, VSD BLEEDER 2.4K Ω , 100W
3RES - 8RES	DV/DT RESISTORS, 10 Ω , 100W
RT2	THERMISTOR TEMPERATURE SENSORS
ISCR - 3SCR	SCR/DIODE MODULES, 285A, 1200V
IR	RELAY, COOLING FANS AND PUMP
ISW	CIRCUIT BREAKER, 600A, 600V, 100% RATED
IT	120VAC, 3KVA CONTROL POWER TRANSFORMER
2T	24VAC, 75VA CONTROL TRANSFORMER
3T - 5T	OUTPUT CURRENT TRANSFORMERS
1TB - 2TB	TERMINAL BLOCKS, FIELD WIRING

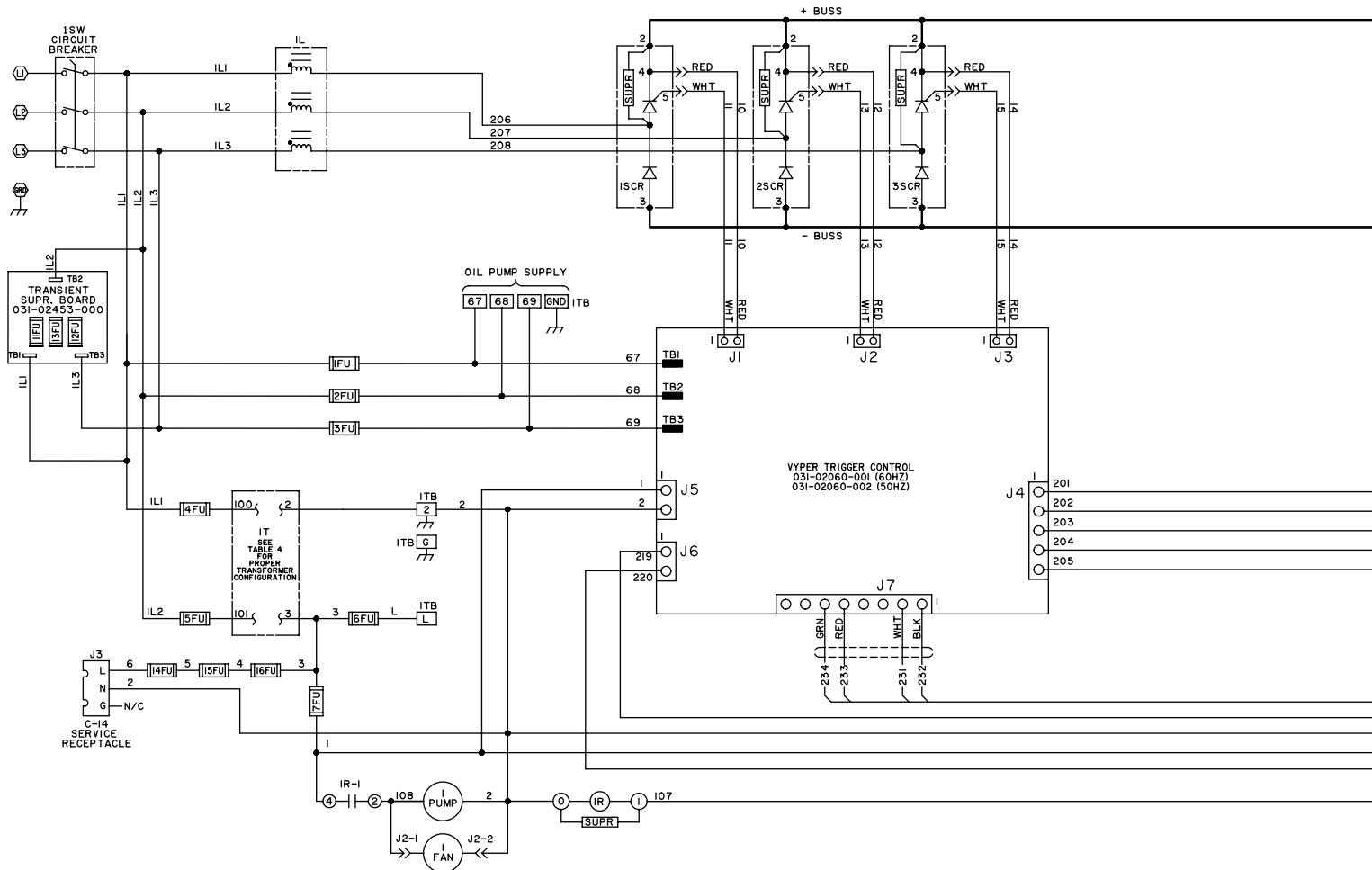
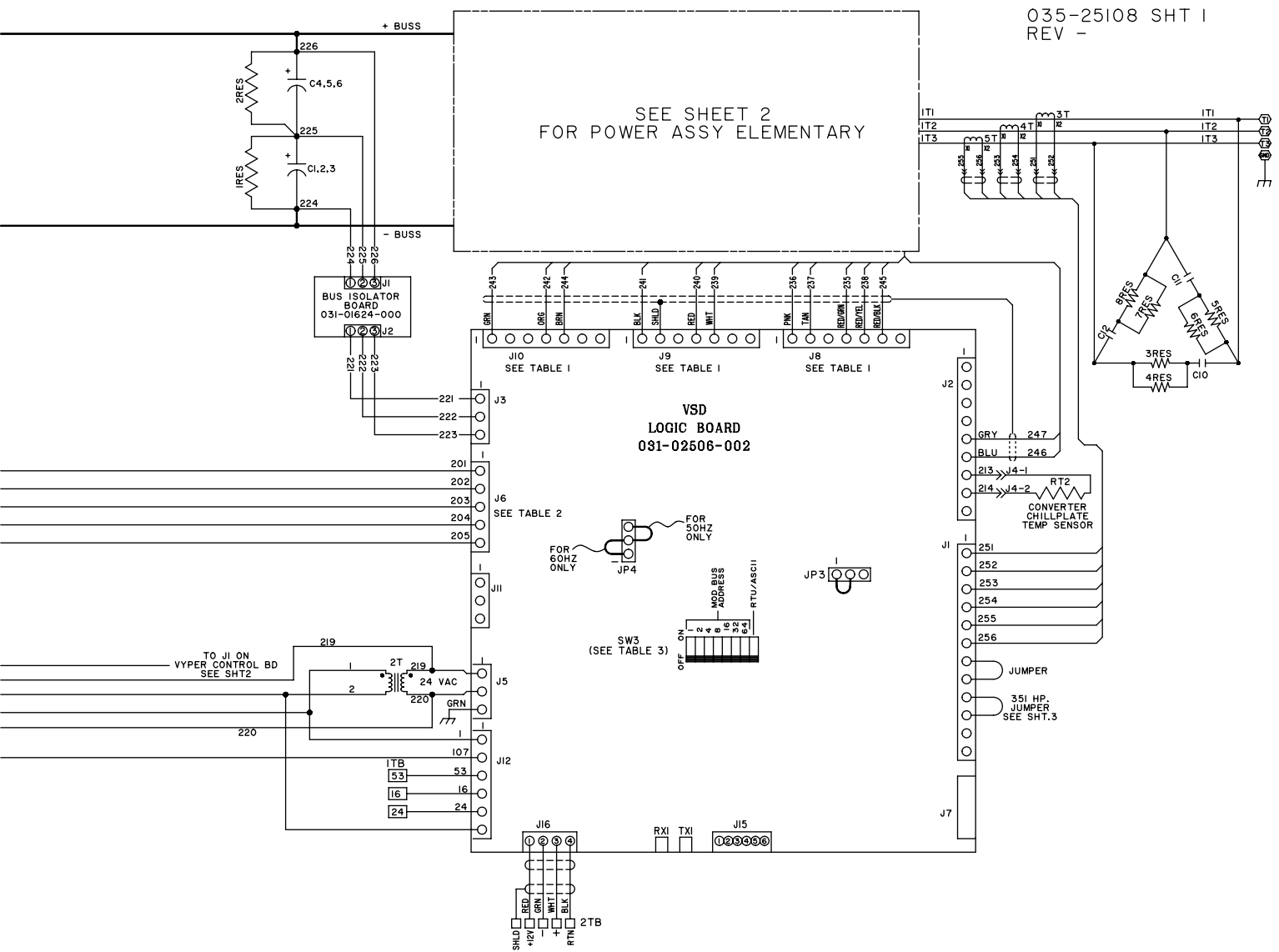

TABLE 4

	460V (60HZ) 351HP	380V/400V (50HZ) 292HP	380V/400V (60HZ) 270HP	415V (50HZ) 292HP	400V (60HZ) 270HP
PANEL P/N 371-06976-XXX	-702	-706	-722	-726	-746
IT TRANSFORMER CONFIGURATION					

LD22488

FIGURE 28 - ELEMENTARY WIRING DIAGRAM 270/292/351 HP FOR LVD MODELS GLOBAL DESIGN



035-25108 SHT 1
REV -

SEE SHEET 2
FOR POWER ASSY ELEMENTARY

VSD
LOGIC BOARD
031-02506-002

TABLE 1
VYPERLOGIC BOARD - J8, J9, J10 PINOUT

CONNECTOR PIN	FUNCTION
1	FAULT
2	GND/SHLD
3	+5V
4	UPPER PHASE
5	LOWER PHASE
6	SW, +7.5V
7	GND/SHLD

TABLE 2
VYPERLOGIC BOARD - J6 PINOUT

CONNECTOR PIN	FUNCTION
1	+5V FEED
2	PH LOSS OUT
3	PRECHG IN
4	SCRTRIG IN
5	+7.5V FEED

TABLE 3
SW3 POSITIONS

POSITION NUMBER	ASCII MODBUS PROTOCOL MODELS	RTU MODBUS PROTOCOL MODELS
1	ON	ON
2	OFF	OFF
4	OFF	OFF
8	OFF	OFF
16	OFF	OFF
32	OFF	OFF
64	OFF	OFF
RTU/ASCII	ON	OFF

LD22489

FIGURE 28 - ELEMENTARY WIRING DIAGRAM 270/292/351 HP FOR LVD MODELS GLOBAL DESIGN (CONT'D)

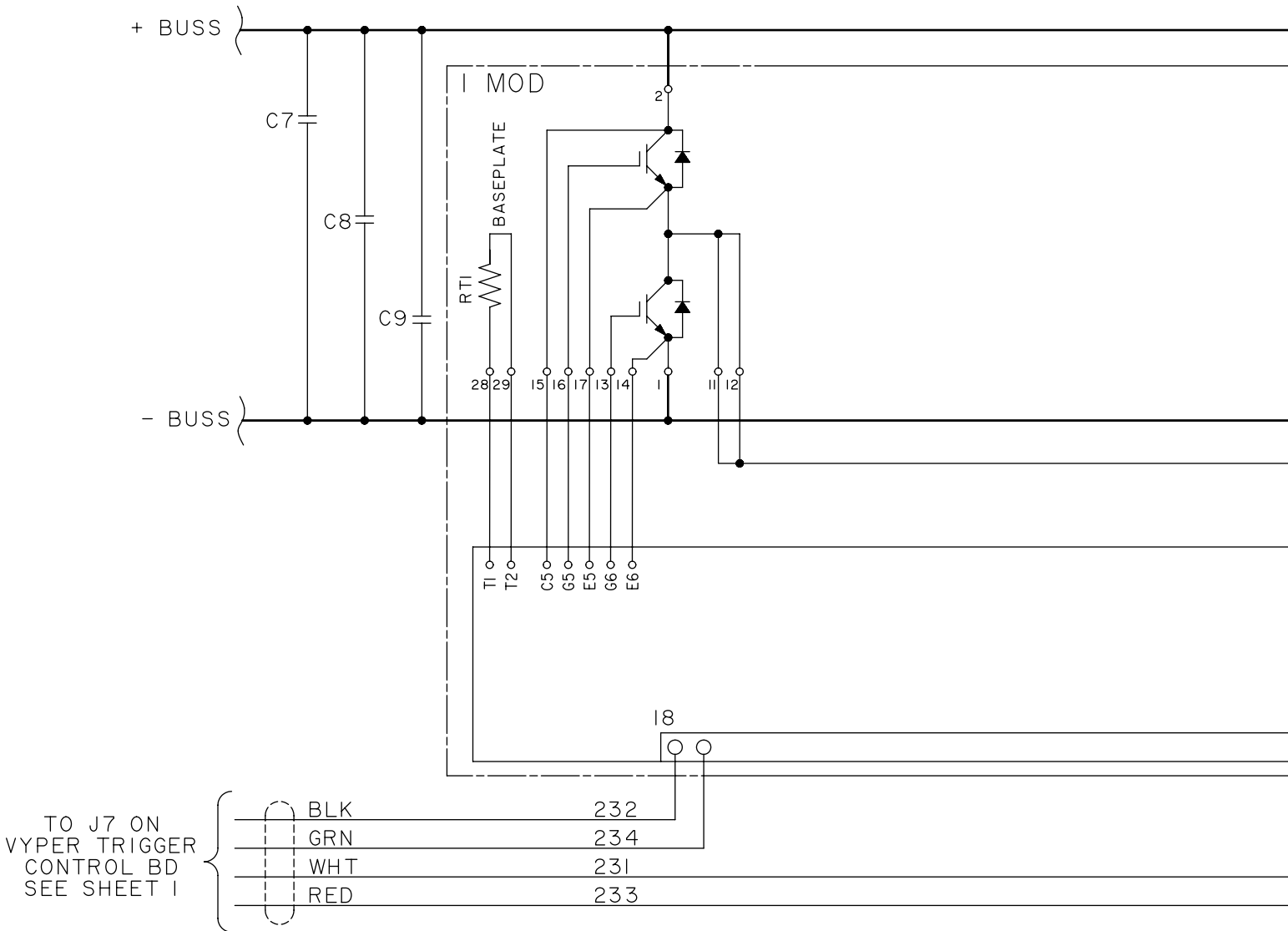

LD22491

FIGURE 29 - POWER ASSEMBLY ELEMENTARY WIRING DIAGRAM 270/292/351 HP FOR LVD MODELS
GLOBAL DESIGN

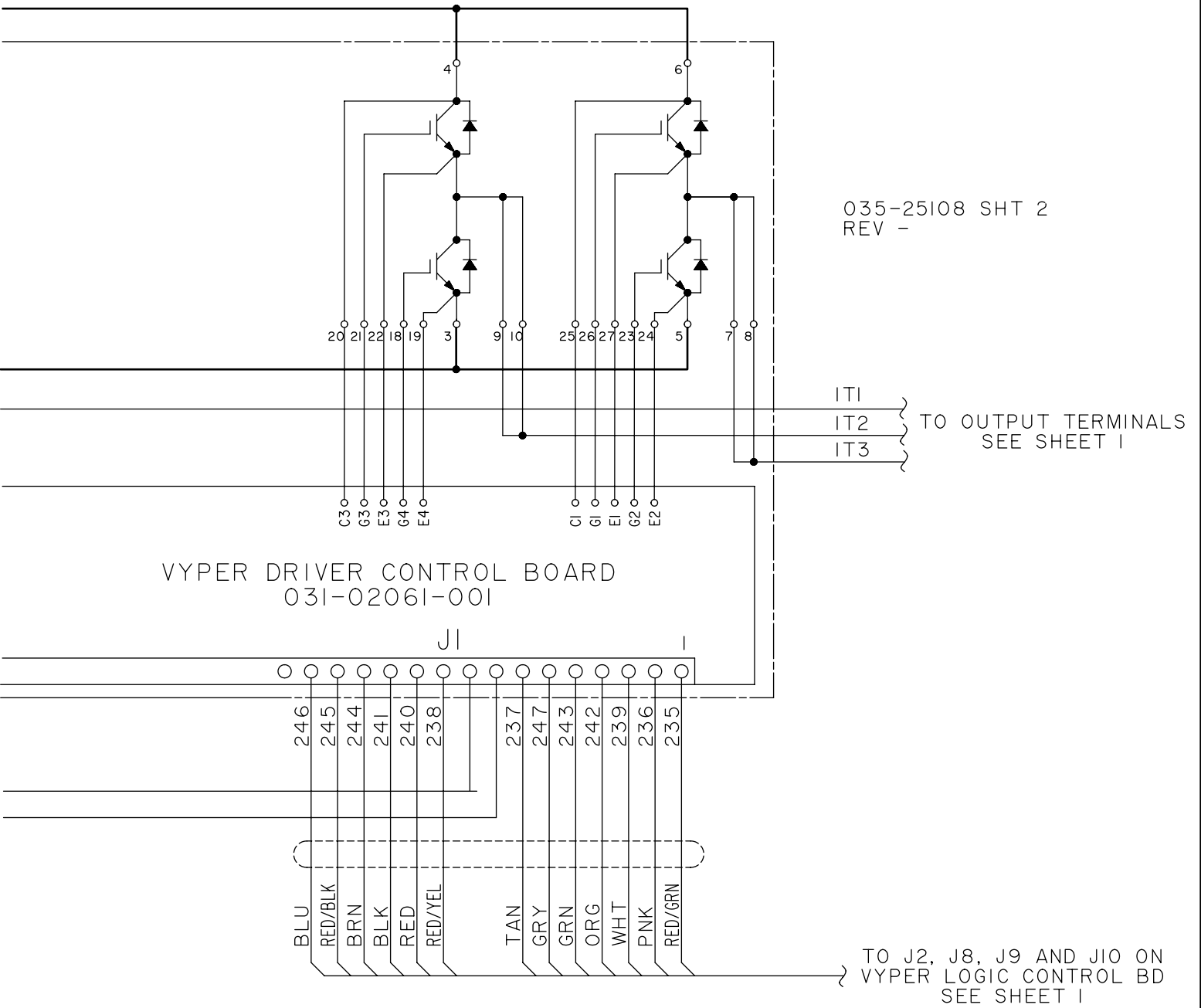
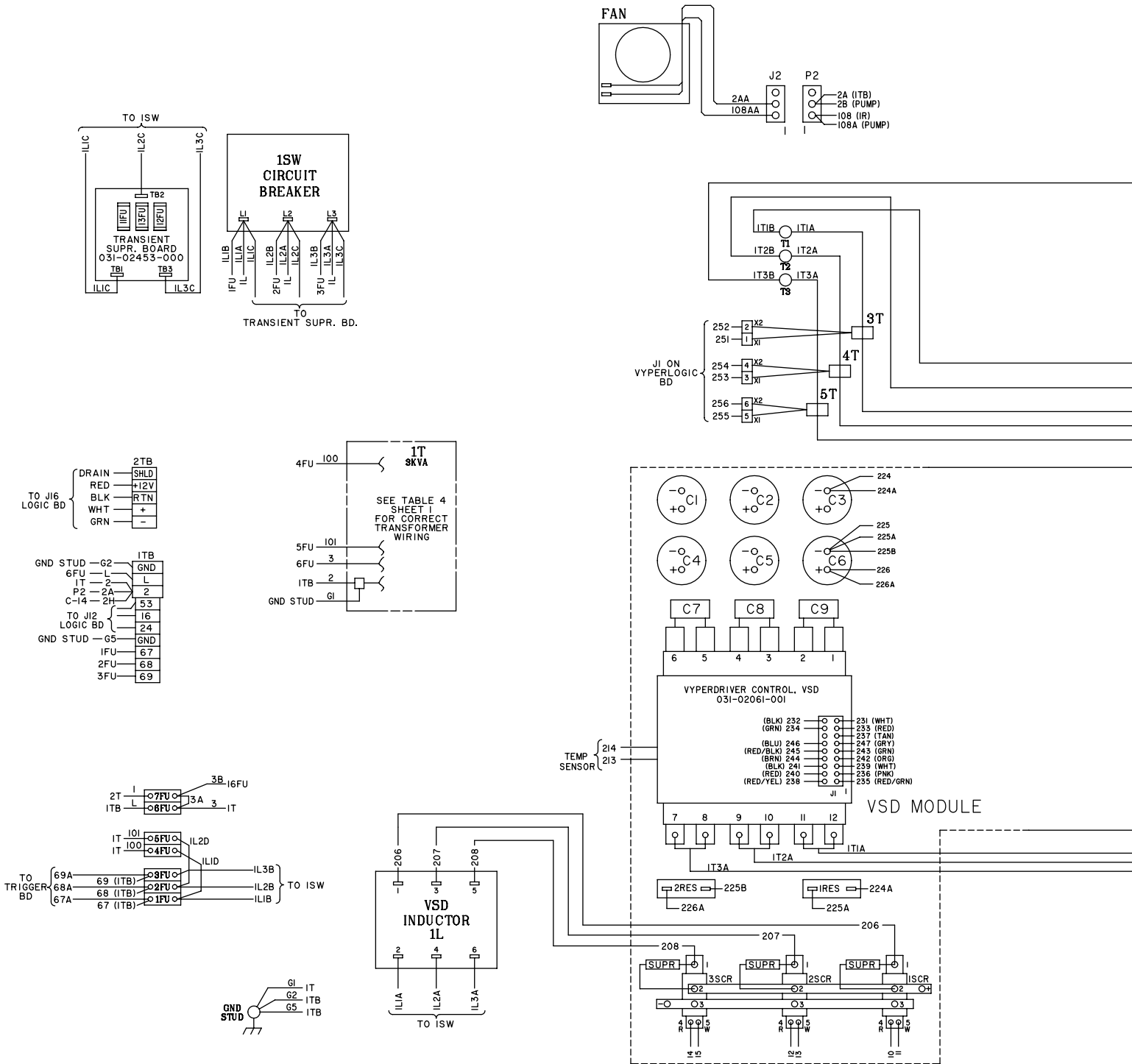

FIGURE 29 - POWER ASSEMBLY ELEMENTARY WIRING DIAGRAM 270/292/351 HP FOR LVD MODELS GLOBAL DESIGN (CONT'D)

LD22491



LD22492

FIGURE 30 - CONNECTION DIAGRAM 270/292/351 HP FOR LVD MODELS GLOBAL DESIGN

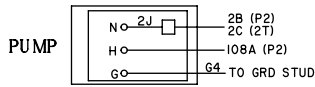

035-25108 SHT 3
REV -

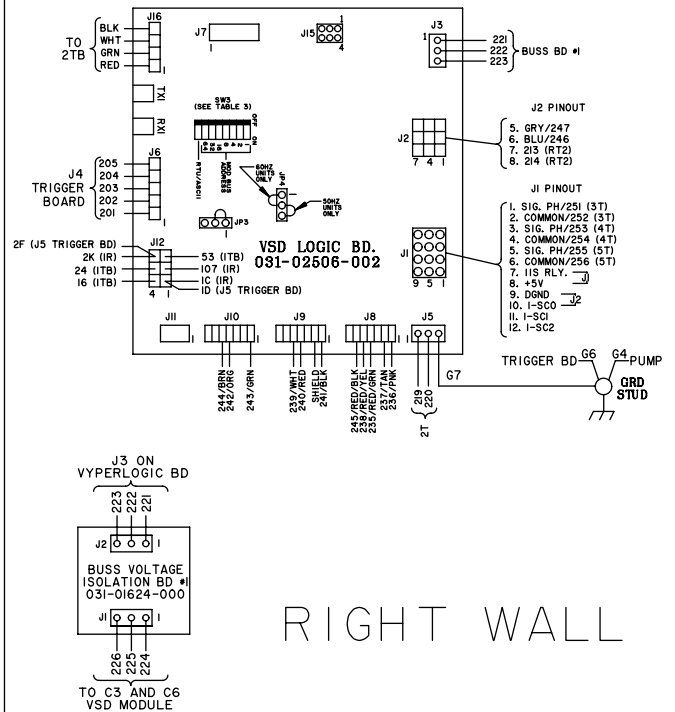
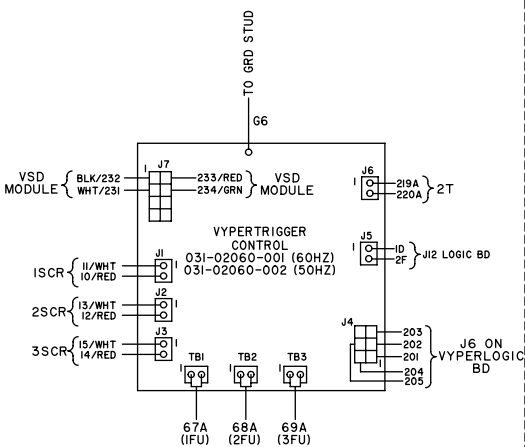
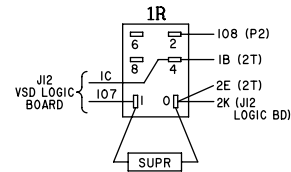
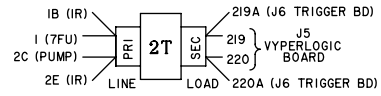
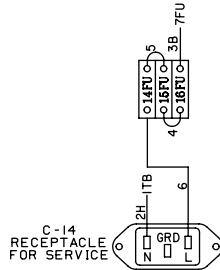
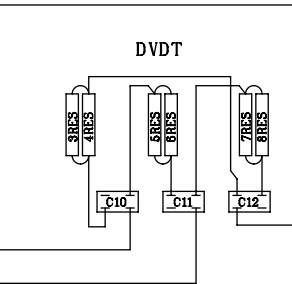

RIGHT WALL

FIGURE 30 - CONNECTION DIAGRAM 270/292/351 HP FOR LVD MODELS GLOBAL DESIGN (CONT'D)

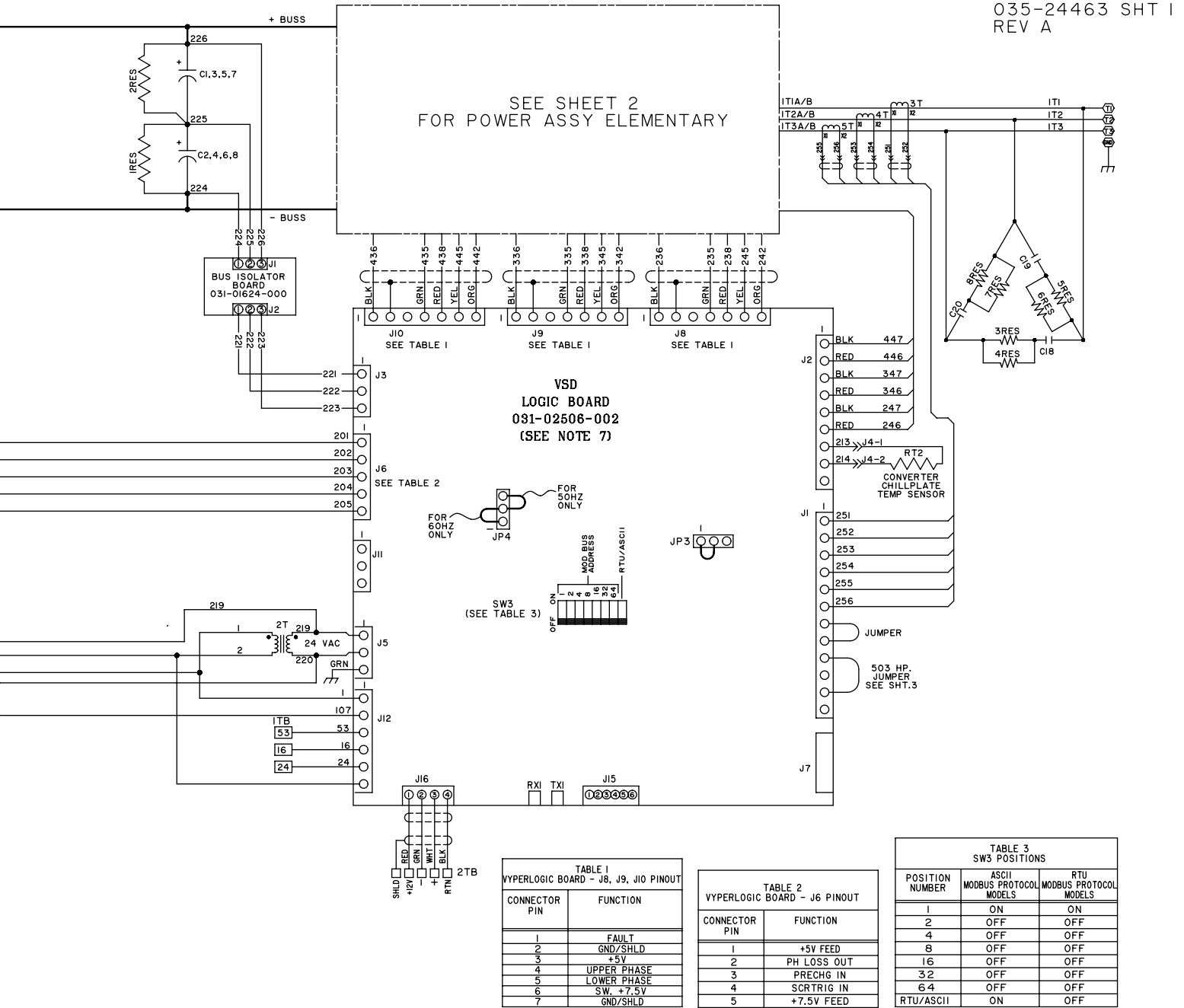
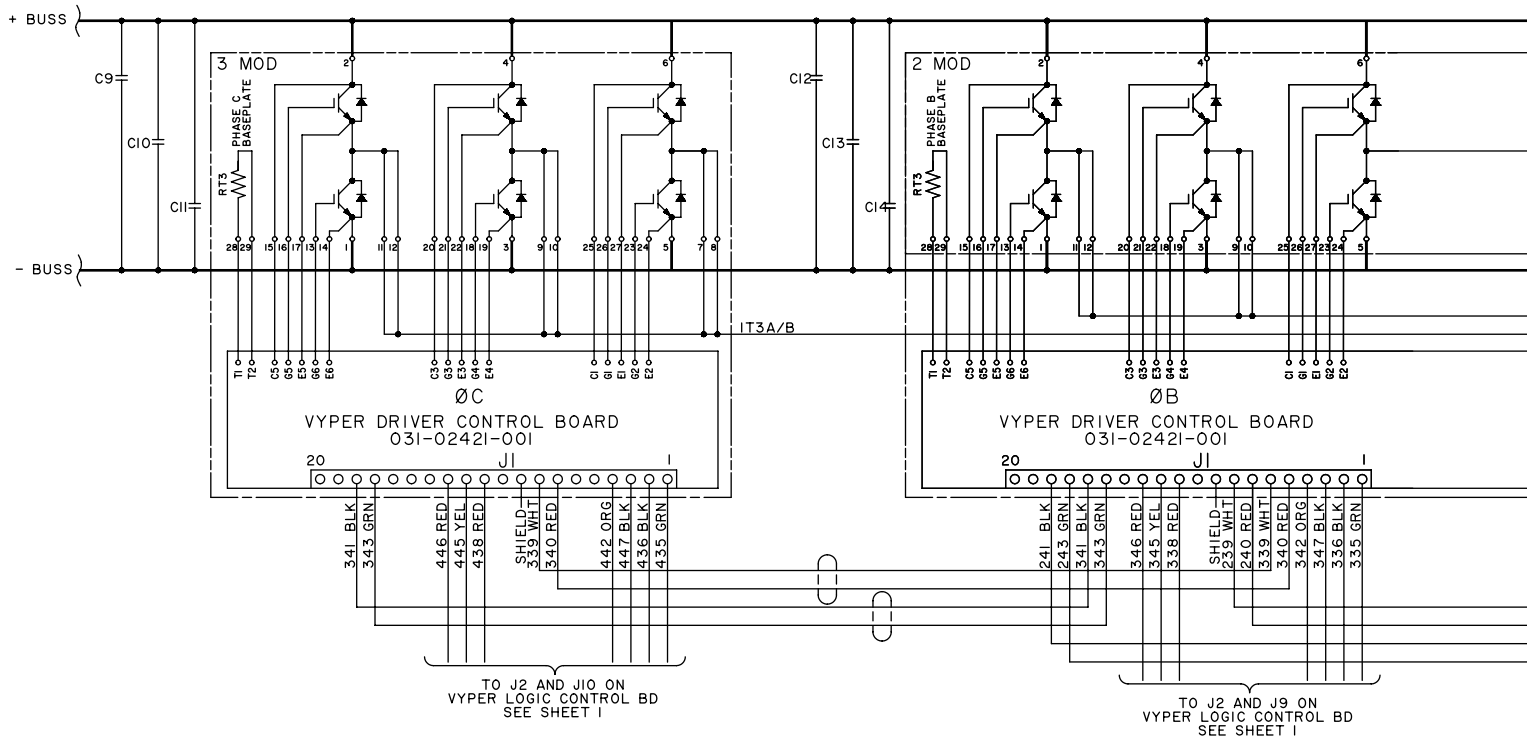

FIGURE 31 - ELEMENTARY WIRING DIAGRAM 385/419/503 HP FOR LVD MODELS GLOBAL DESIGN (CONT'D)

POWER ASSY ELEMENTARY



LD19780

FIGURE 32 - POWER ASSEMBLY ELEMENTARY WIRING DIAGRAM 385/419/503 HP FOR LVD MODELS GLOBAL DESIGN

035-24463 SHT 2
 REV A

3

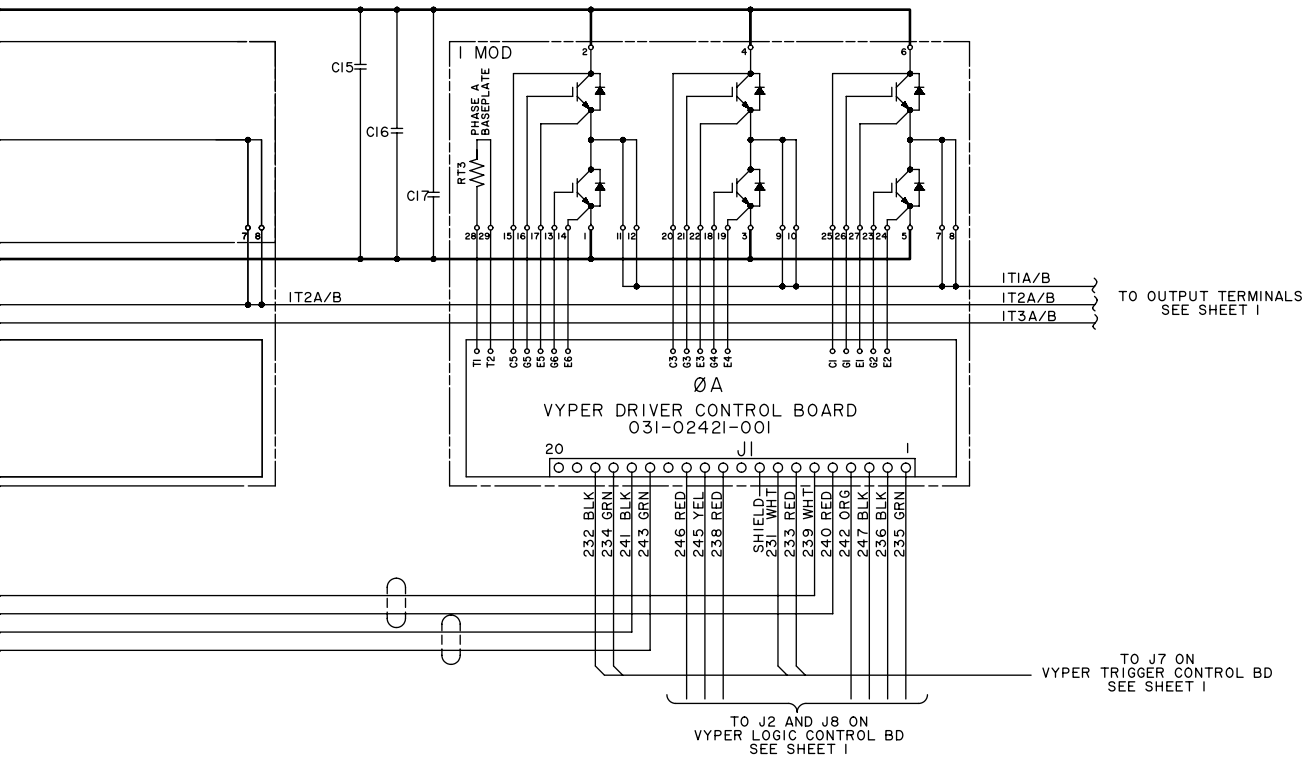

LD19781

FIGURE 32 - POWER ASSEMBLY ELEMENTARY WIRING DIAGRAM 385/419/503 HP FOR LVD MODELS GLOBAL DESIGN (CONT'D)

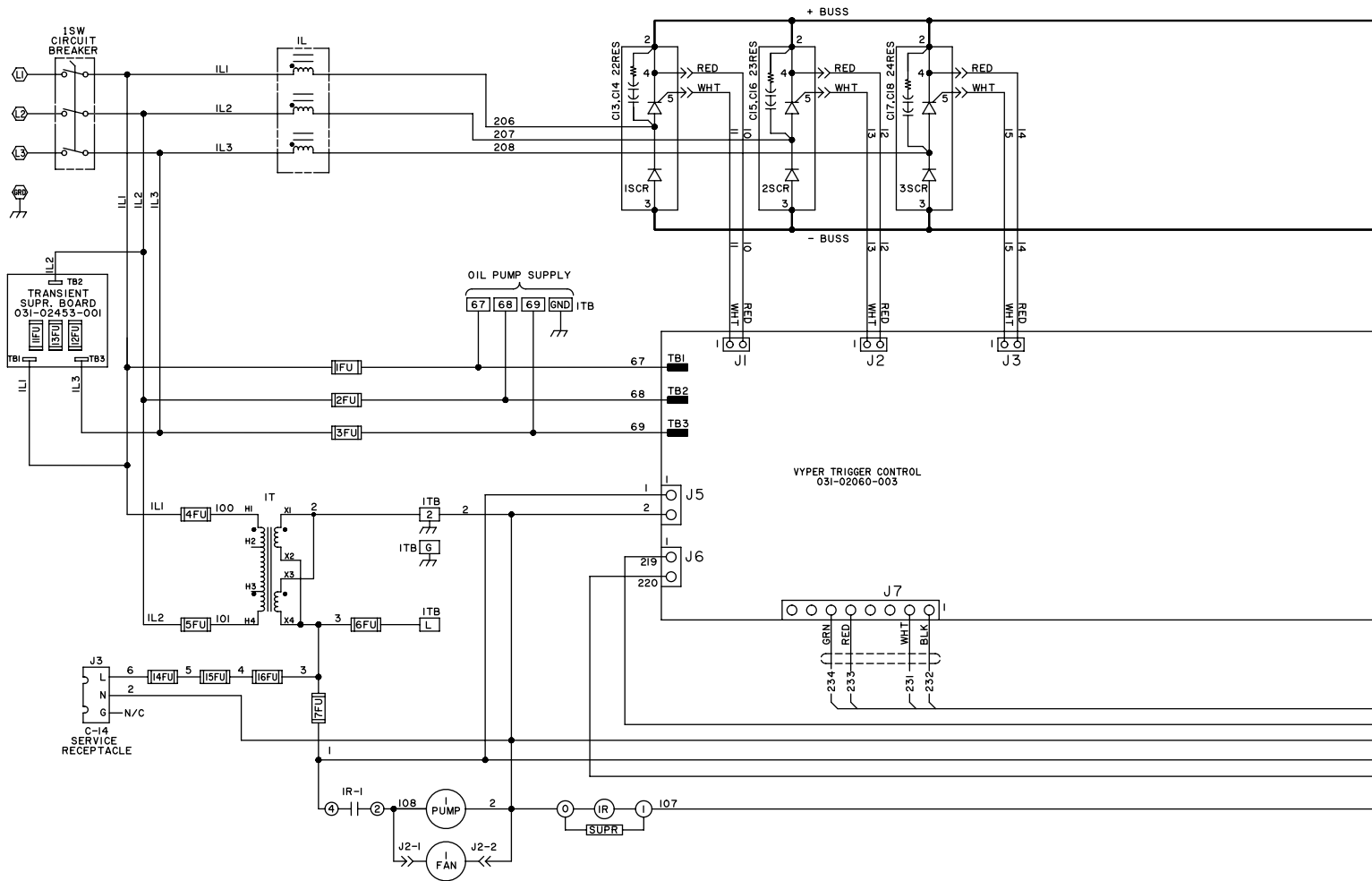

LD22732

FIGURE 33 - ELEMENTARY WIRING DIAGRAM 424 HP FOR LVD MODELS GLOBAL DESIGN

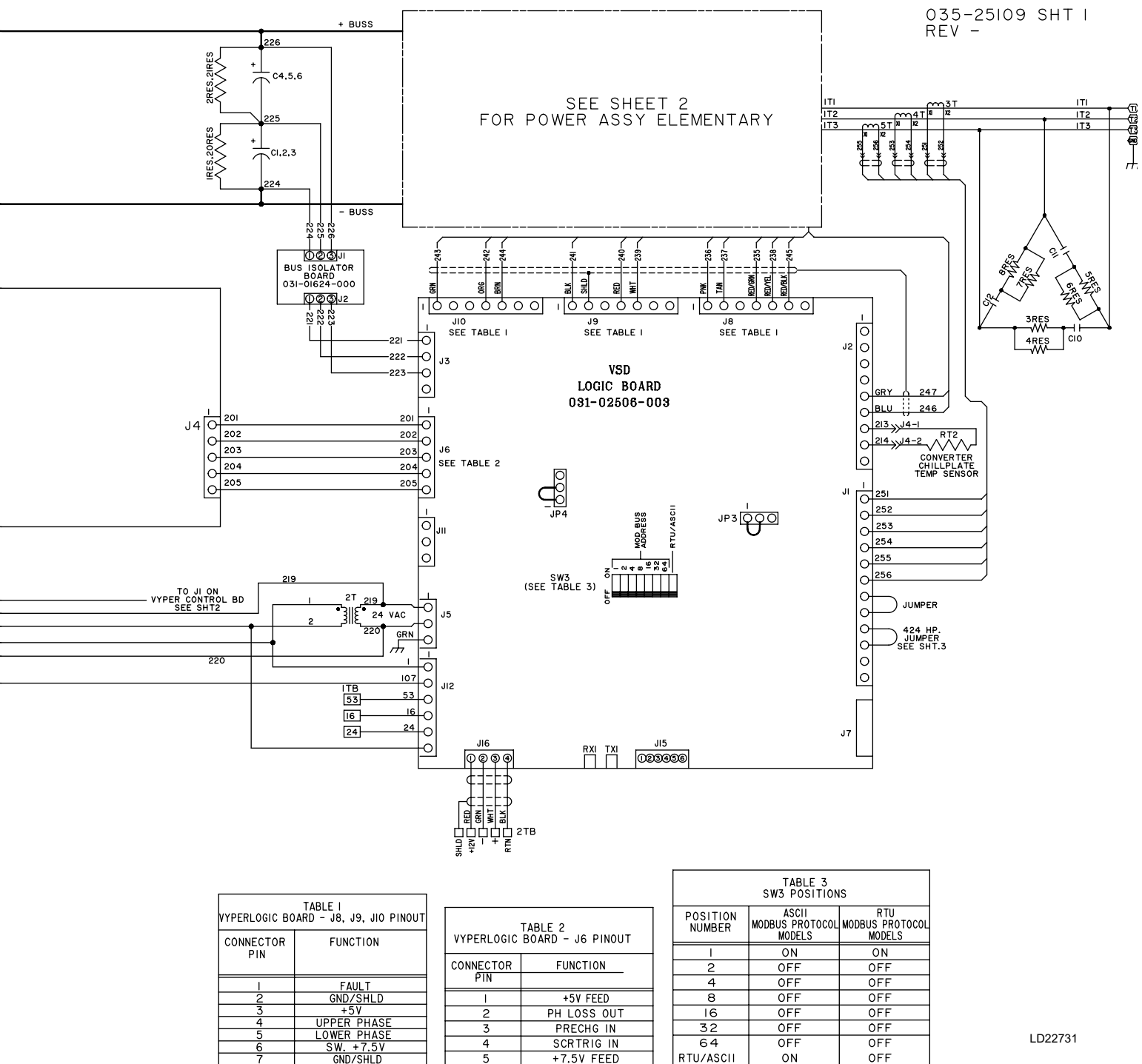

LD22731

FIGURE 33 - ELEMENTARY WIRING DIAGRAM 424 HP FOR LVD MODELS GLOBAL DESIGN (CONT'D)

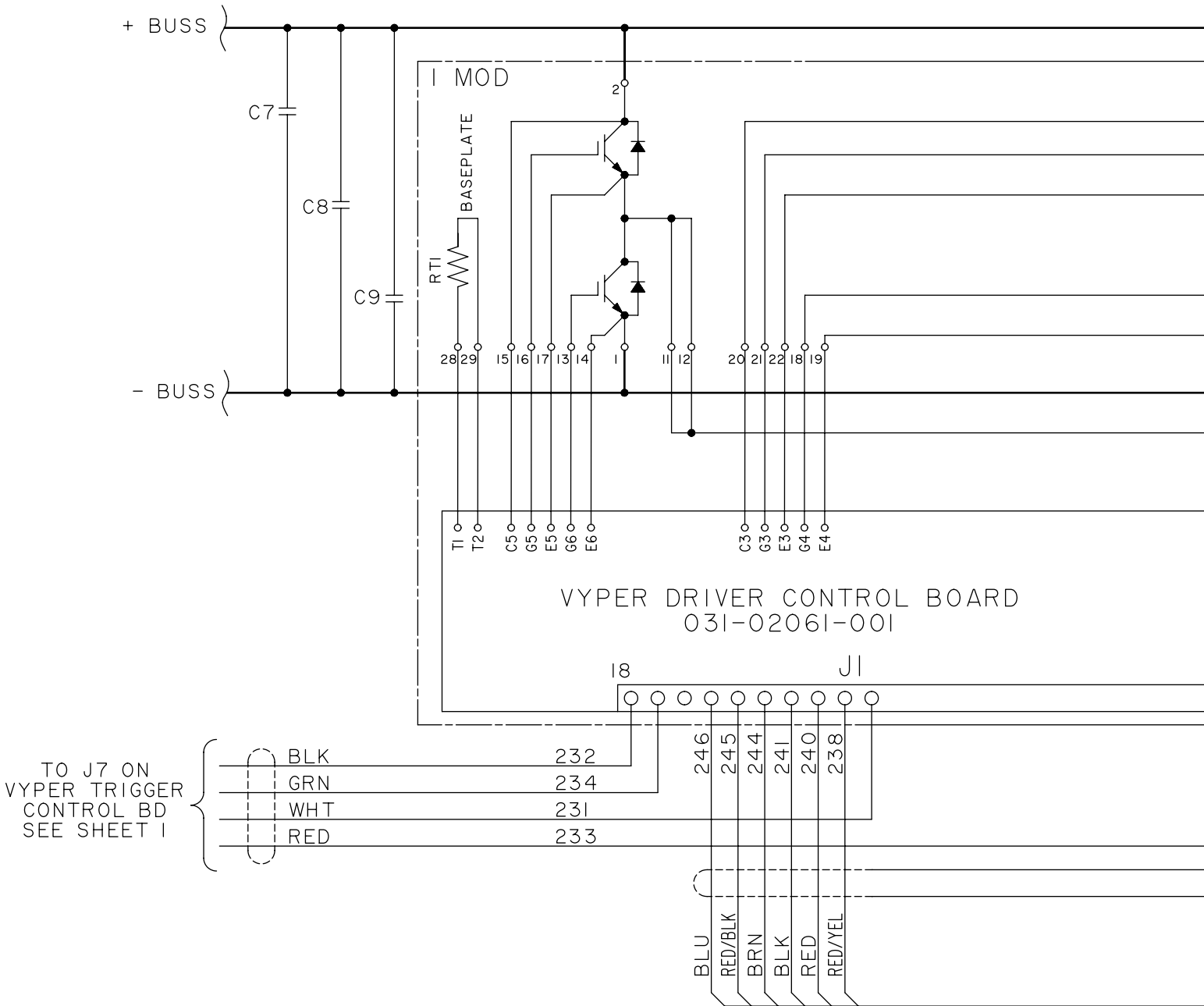

LD22733

FIGURE 34 - POWER ASSEMBLY ELEMENTARY WIRING DIAGRAM 424 HP FOR LVD MODELS
GLOBAL DESIGN

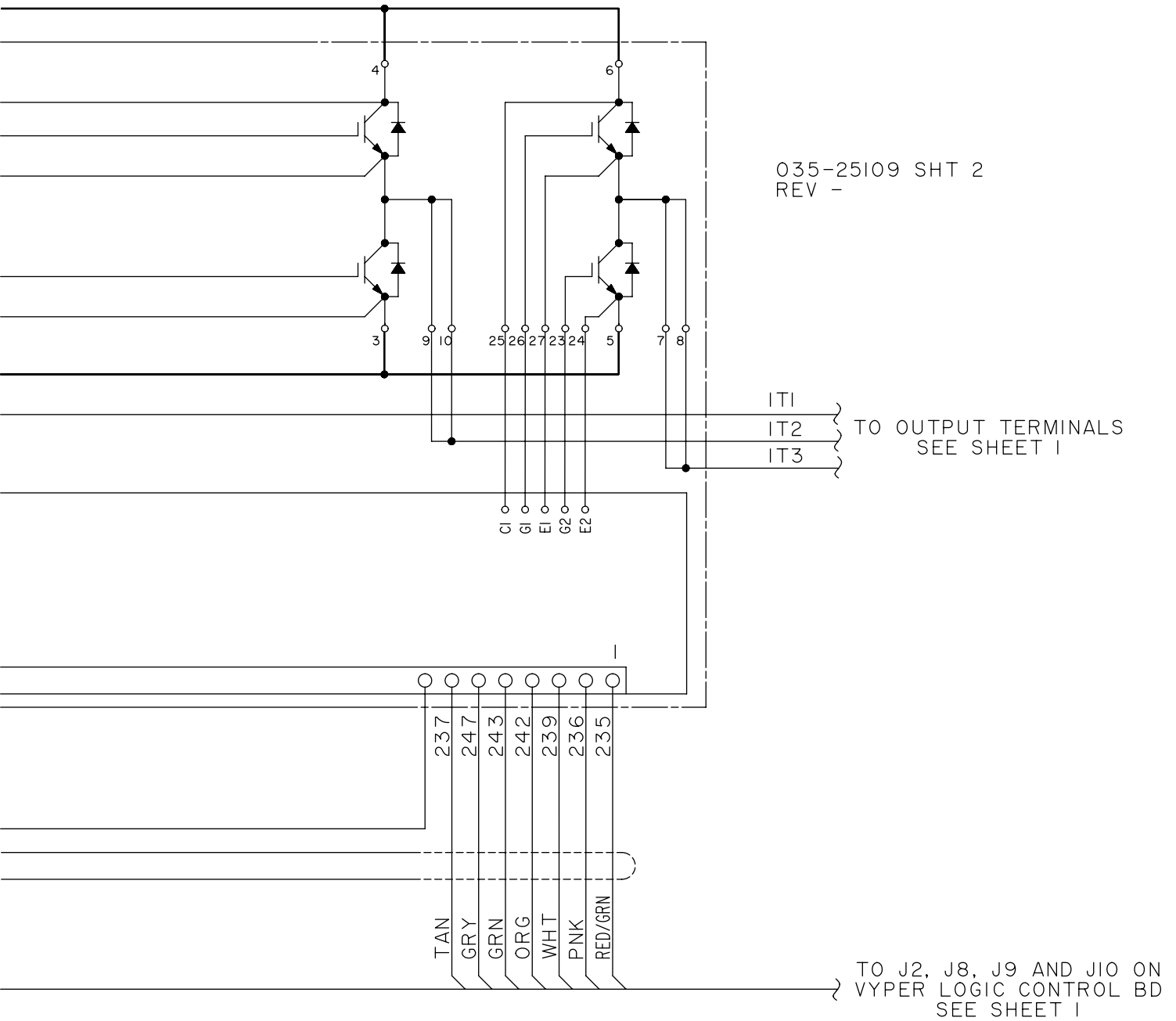

**FIGURE 34 - POWER ASSEMBLY ELEMENTARY WIRING DIAGRAM 424 HP FOR LVD MODELS
 GLOBAL DESIGN (CONT'D)**

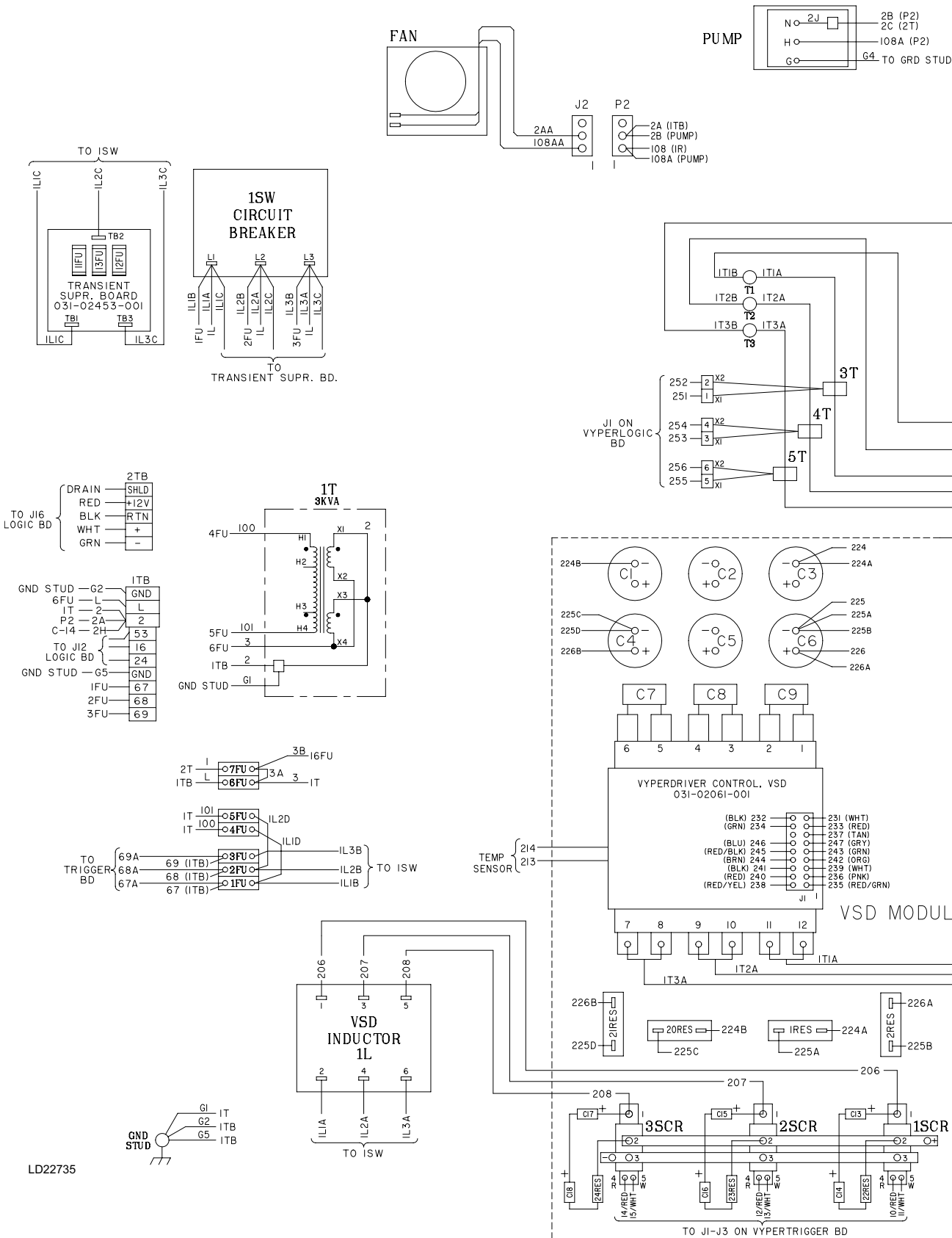

FIGURE 35 - CONNECTION WIRING DIAGRAM 424 HP FOR LVD MODELS GLOBAL DESIGN

035-25109 SHT 3
REV -

3

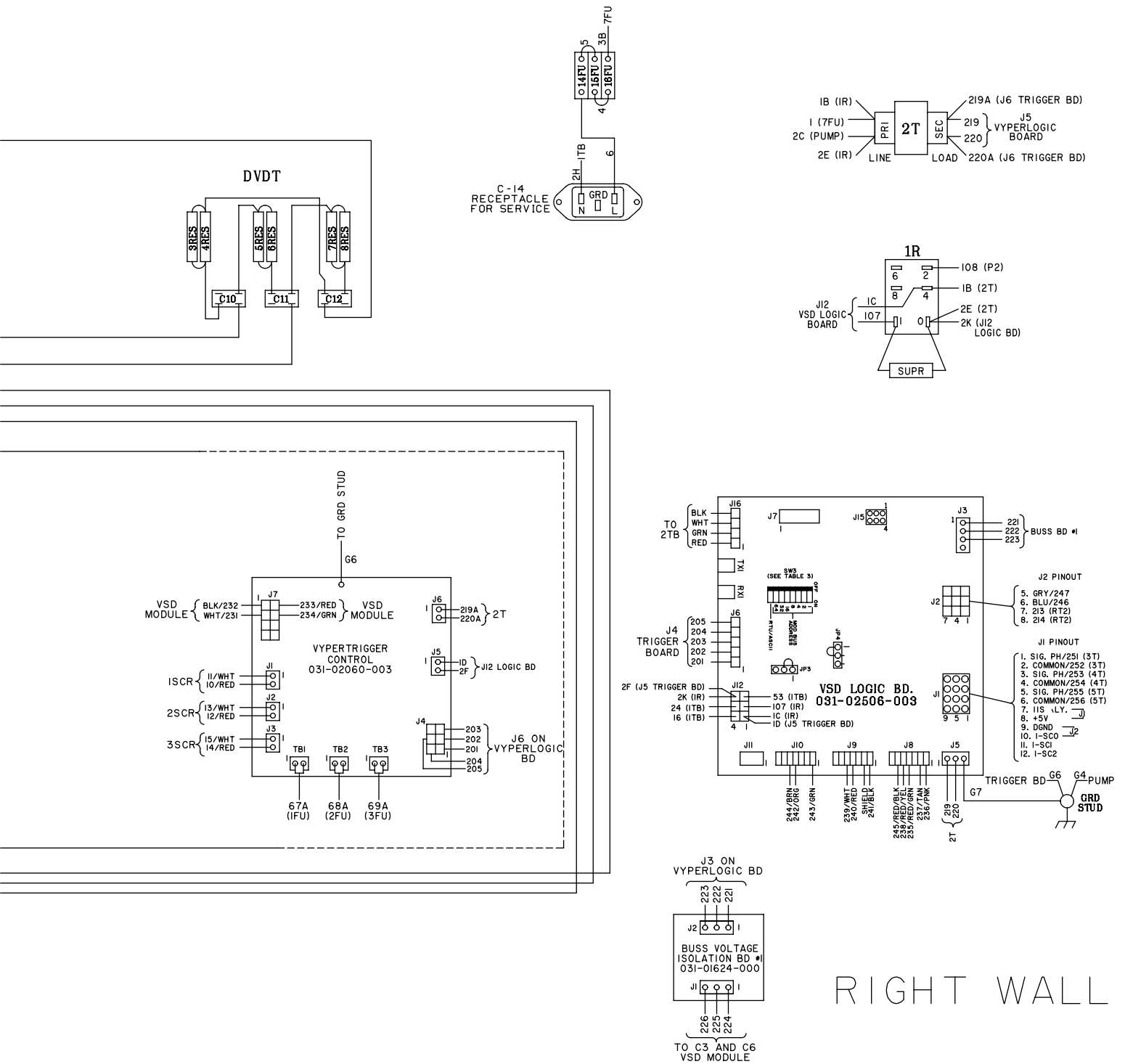
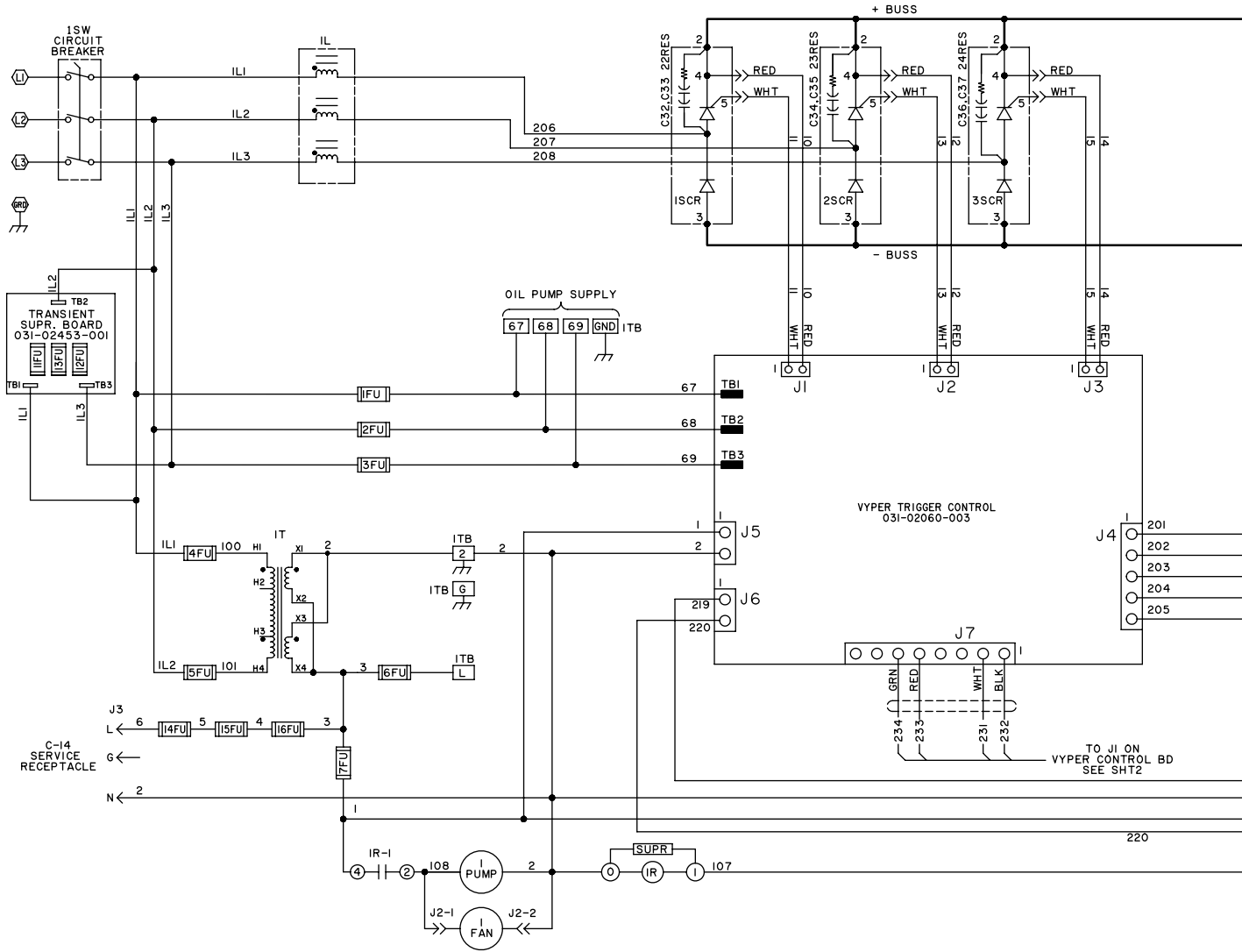

FIGURE 35 - CONNECTION WIRING DIAGRAM 424 HP FOR LVD MODELS GLOBAL DESIGN (CONT'D)



LD19782

FIGURE 36 - ELEMENTARY WIRING DIAGRAM 608 HP FOR LVD MODELS GLOBAL DESIGN

035-24464 SHTI
REV A

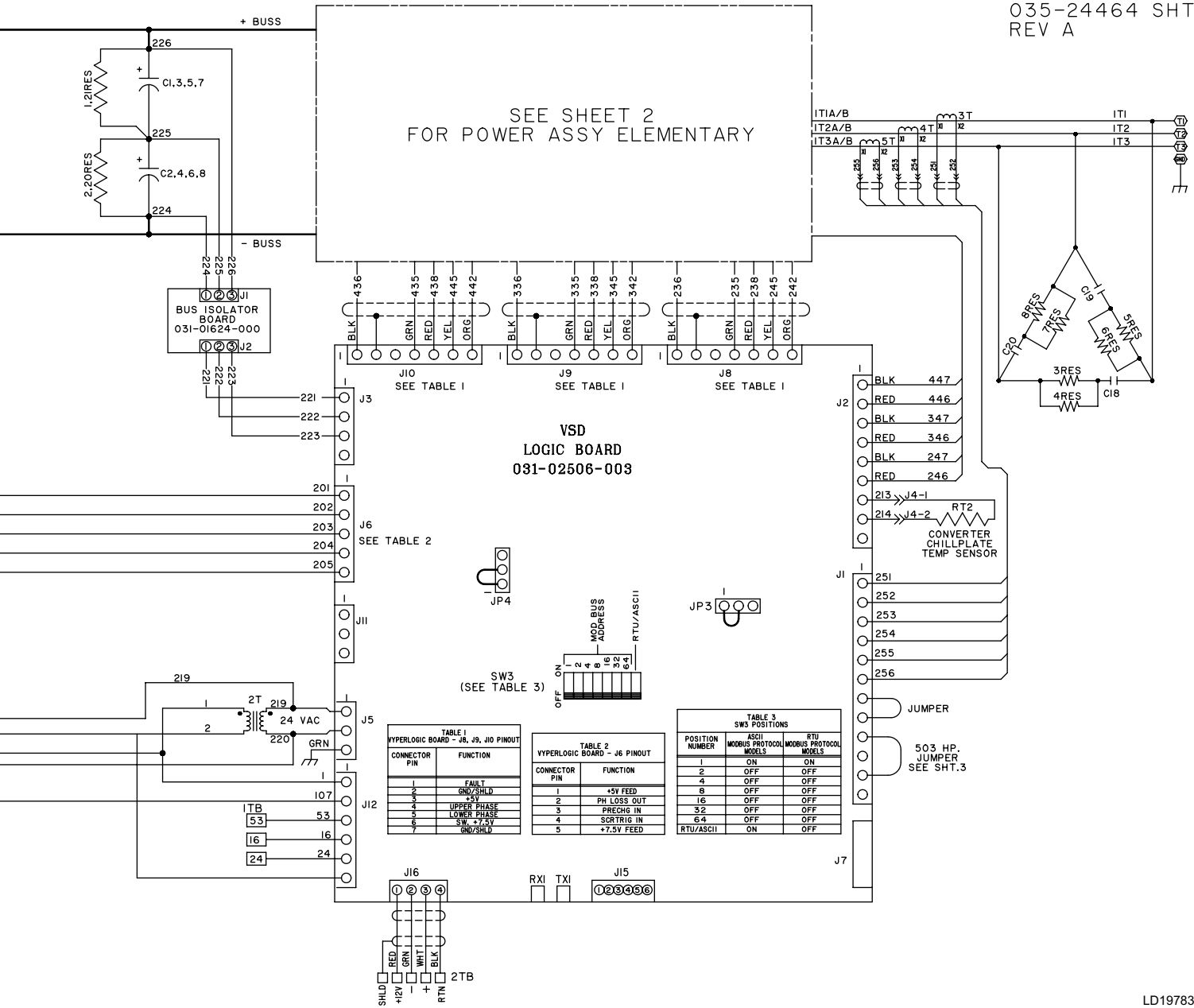
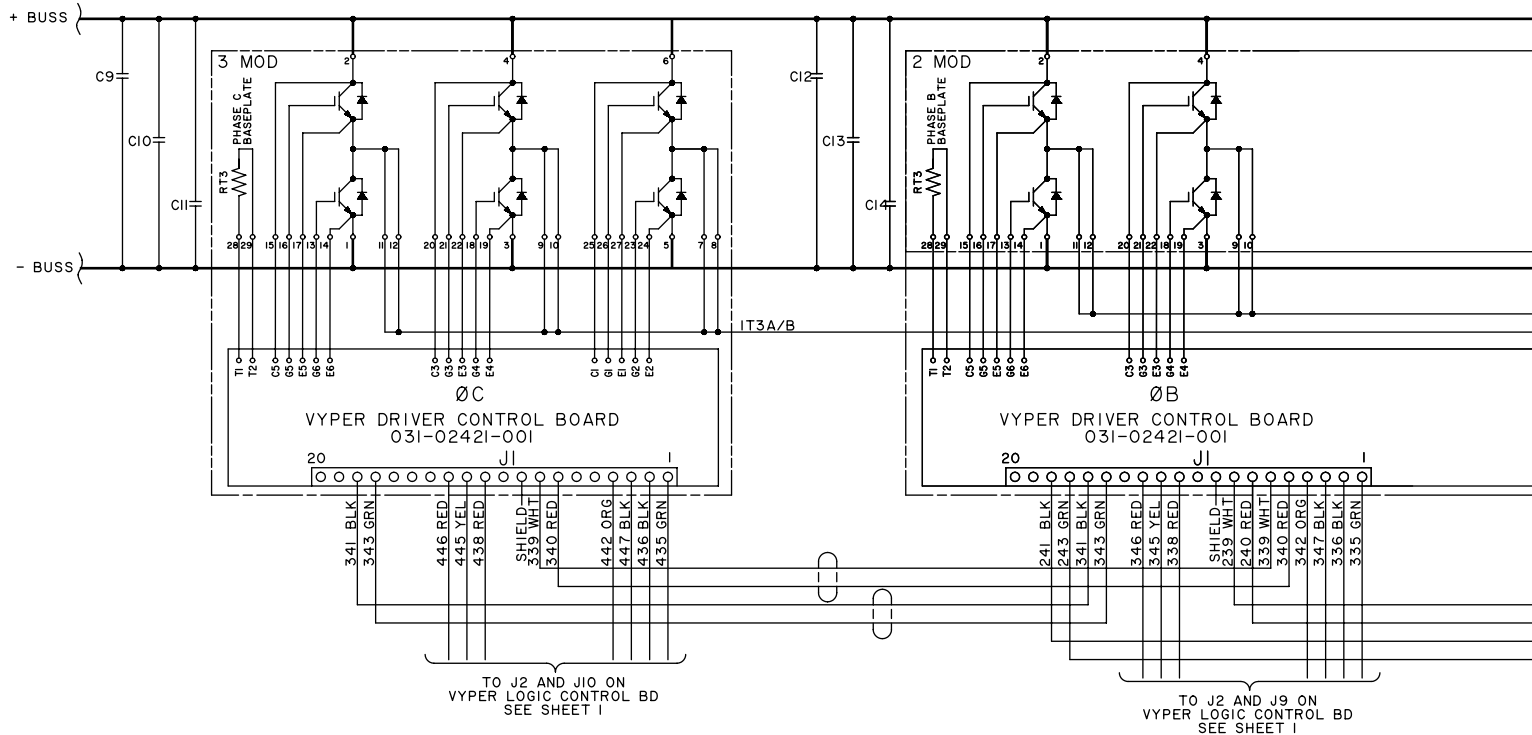

FIGURE 36 - ELEMENTARY WIRING DIAGRAM 608 HP FOR LVD MODELS GLOBAL DESIGN (CONT'D)

POWER ASSY ELEMENTARY



LD19784

FIGURE 37 - POWER ASSEMBLY ELEMENTARY WIRING DIAGRAM 608 HP FOR LVD MODELS GLOBAL DESIGN

035-24464 SHT 2
 REV A

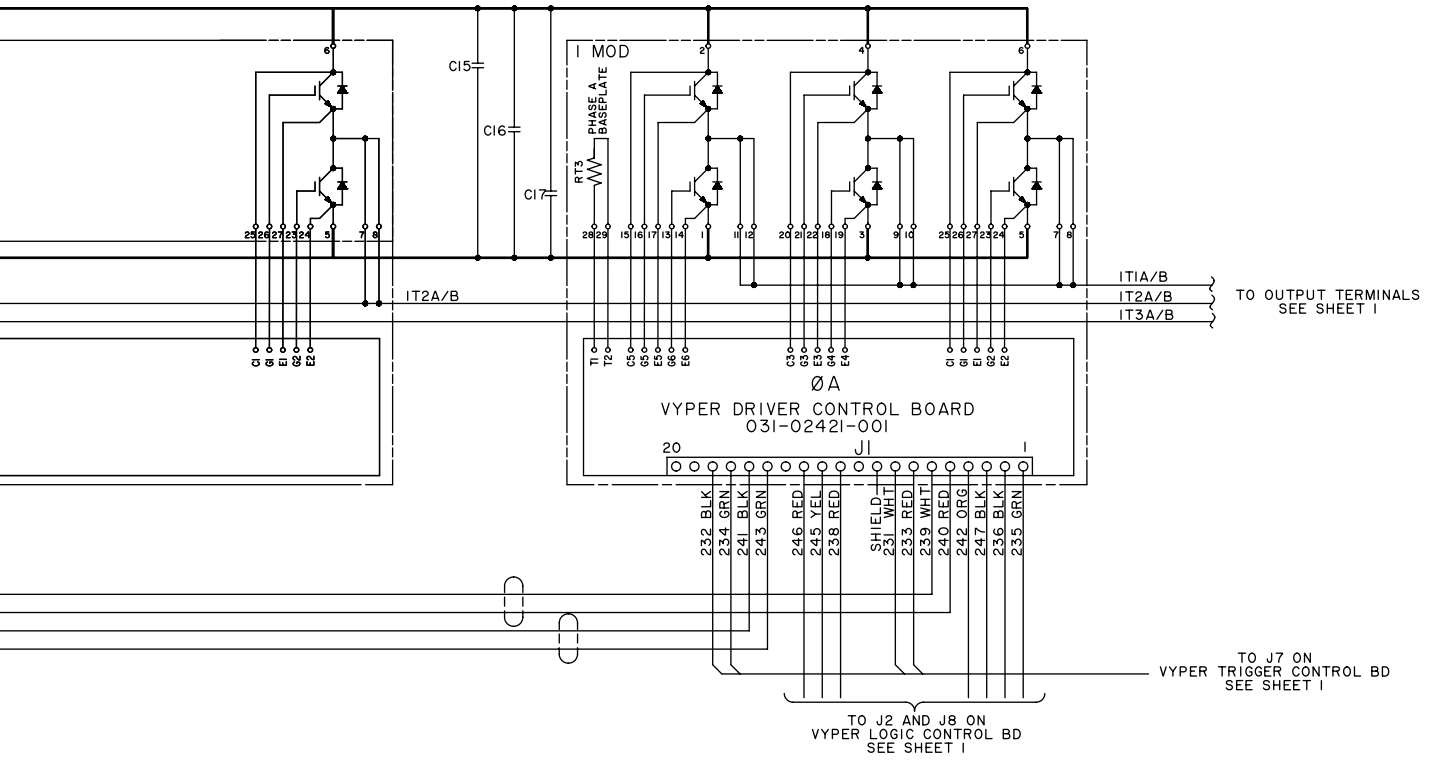

LD19785

FIGURE 37 - POWER ASSEMBLY ELEMENTARY WIRING DIAGRAM 608 HP FOR LVD MODELS GLOBAL DESIGN (CONT'D)

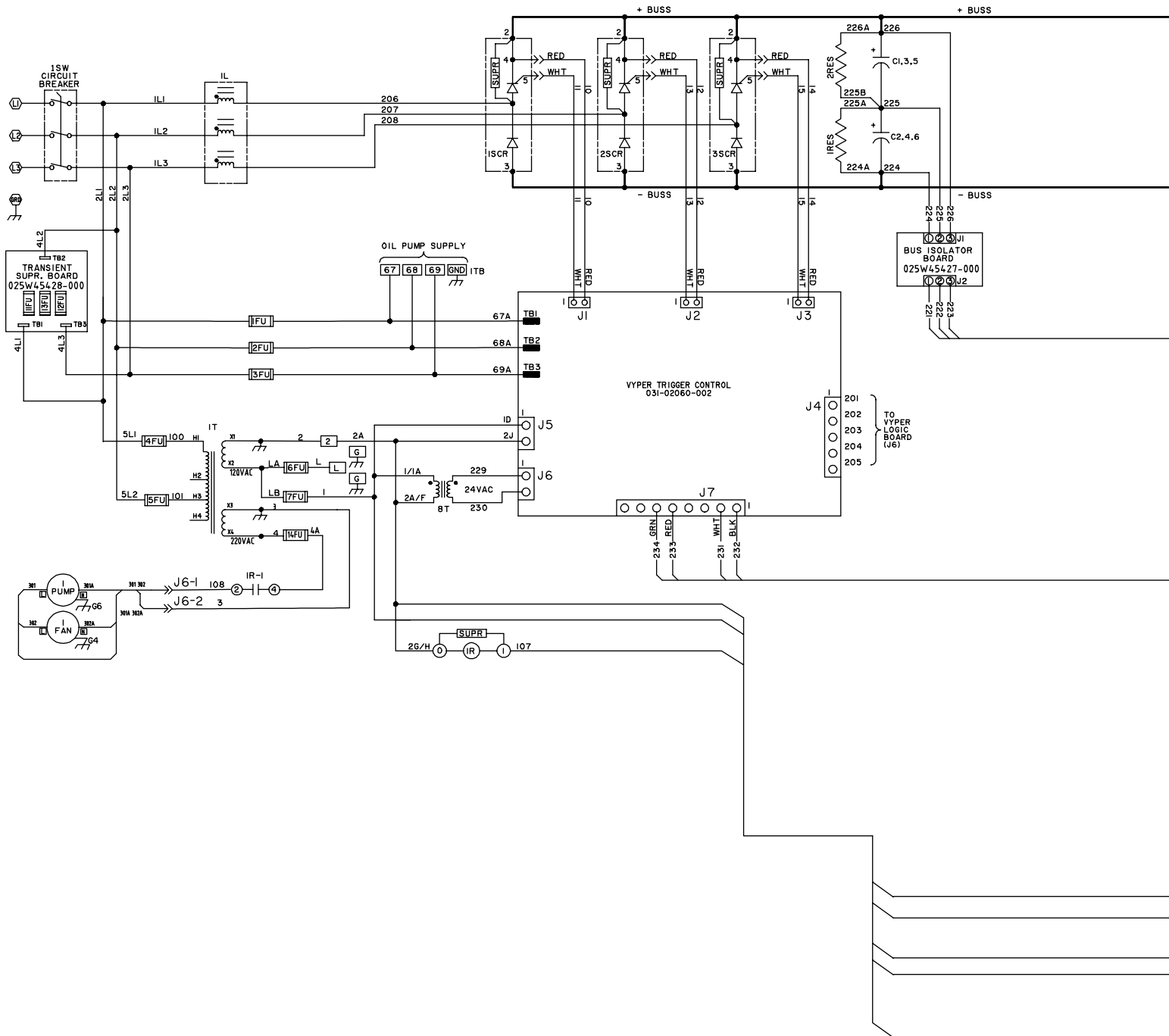

LD22775

FIGURE 38 - ELEMENTARY WIRING DIAGRAM 292 HP FOR LVD MODELS ASIA DESIGN

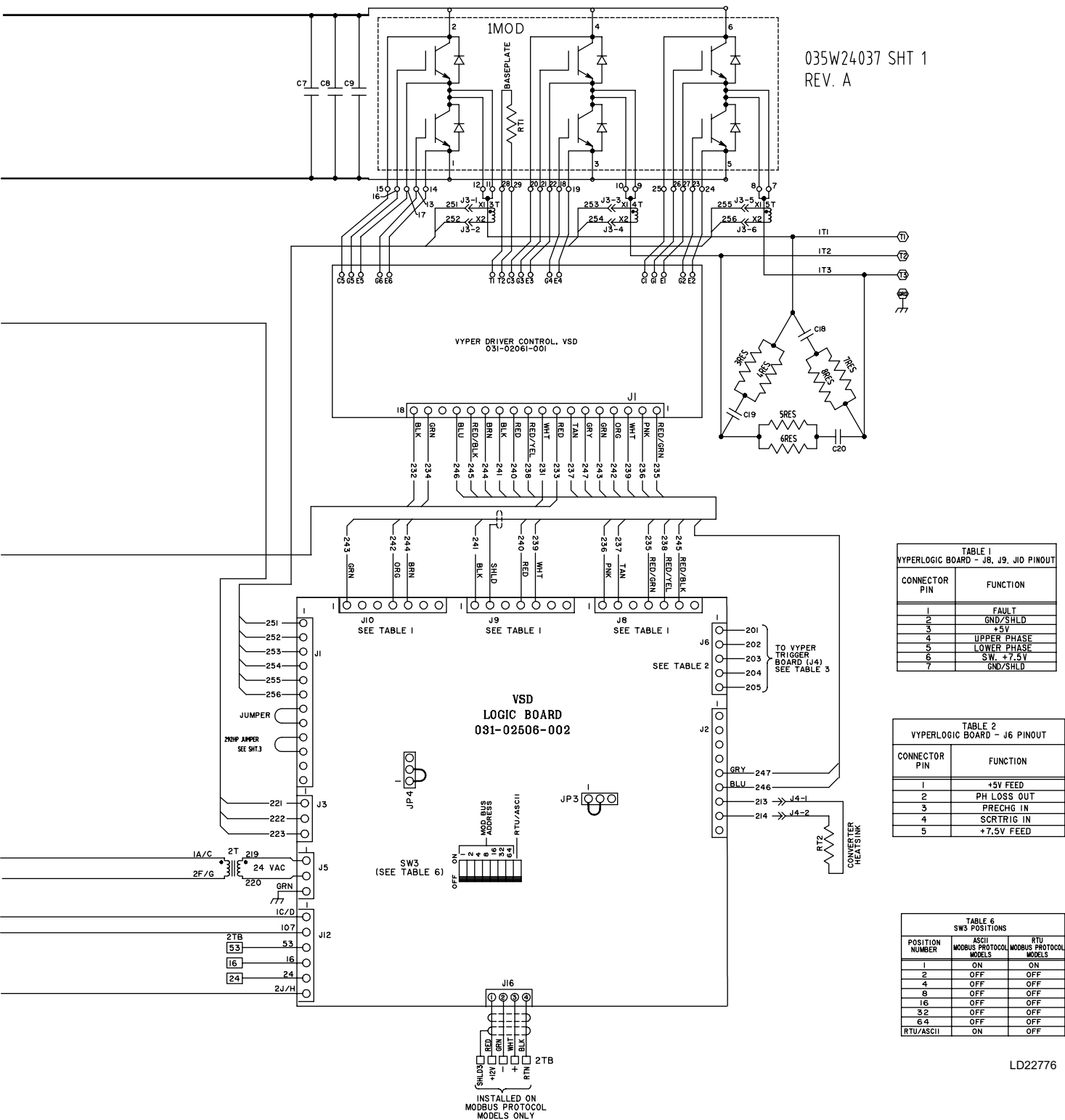
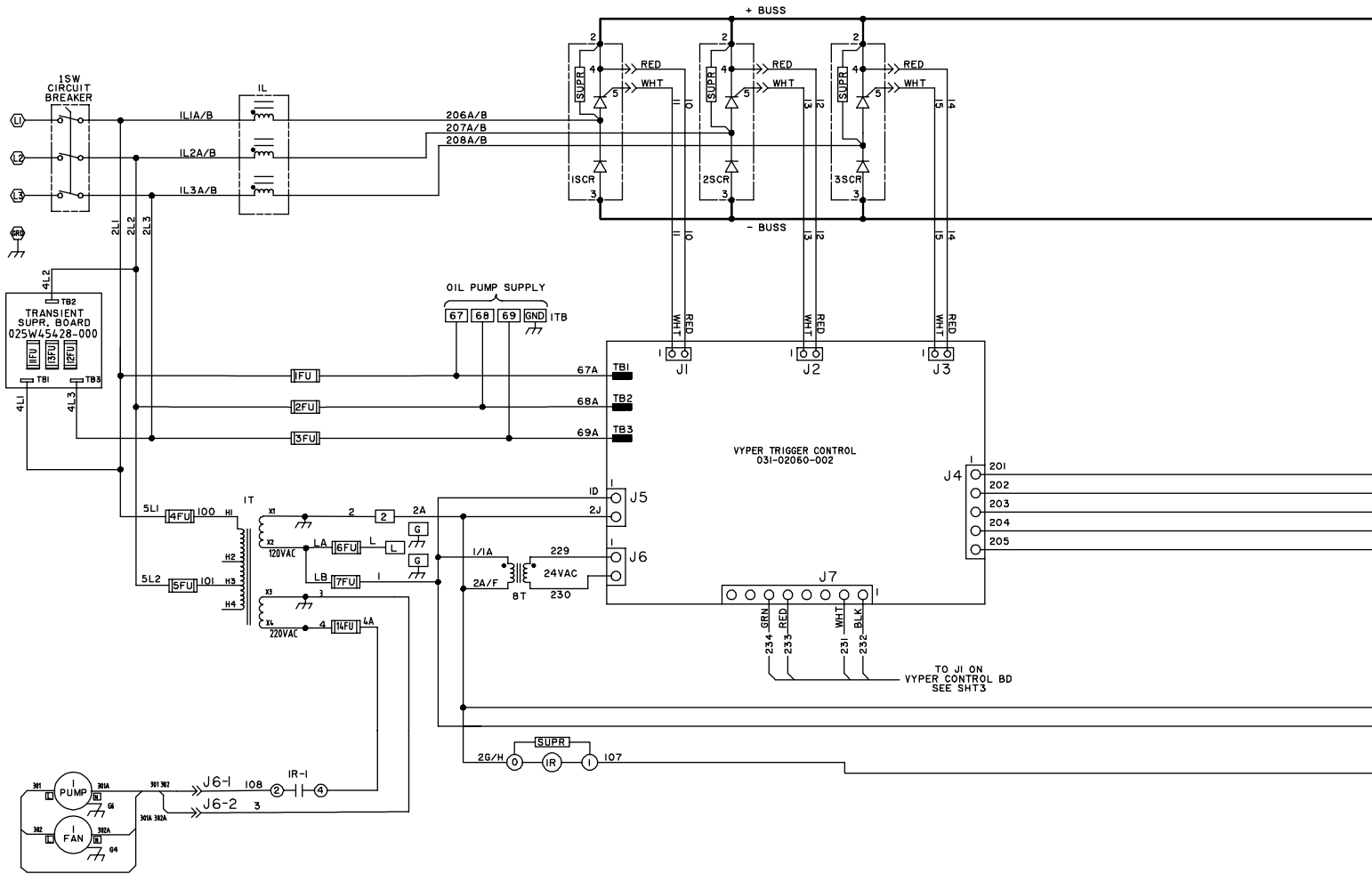

FIGURE 38 - ELEMENTARY WIRING DIAGRAM 292 HP FOR LVD MODELS ASIA DESIGN (CONT'D)



LD22777

**FIGURE 39 - ELEMENTARY WIRING DIAGRAM (400V AND 415V 419HP 50HZ)
FOR LVD MODELS ASIA DESIGN**

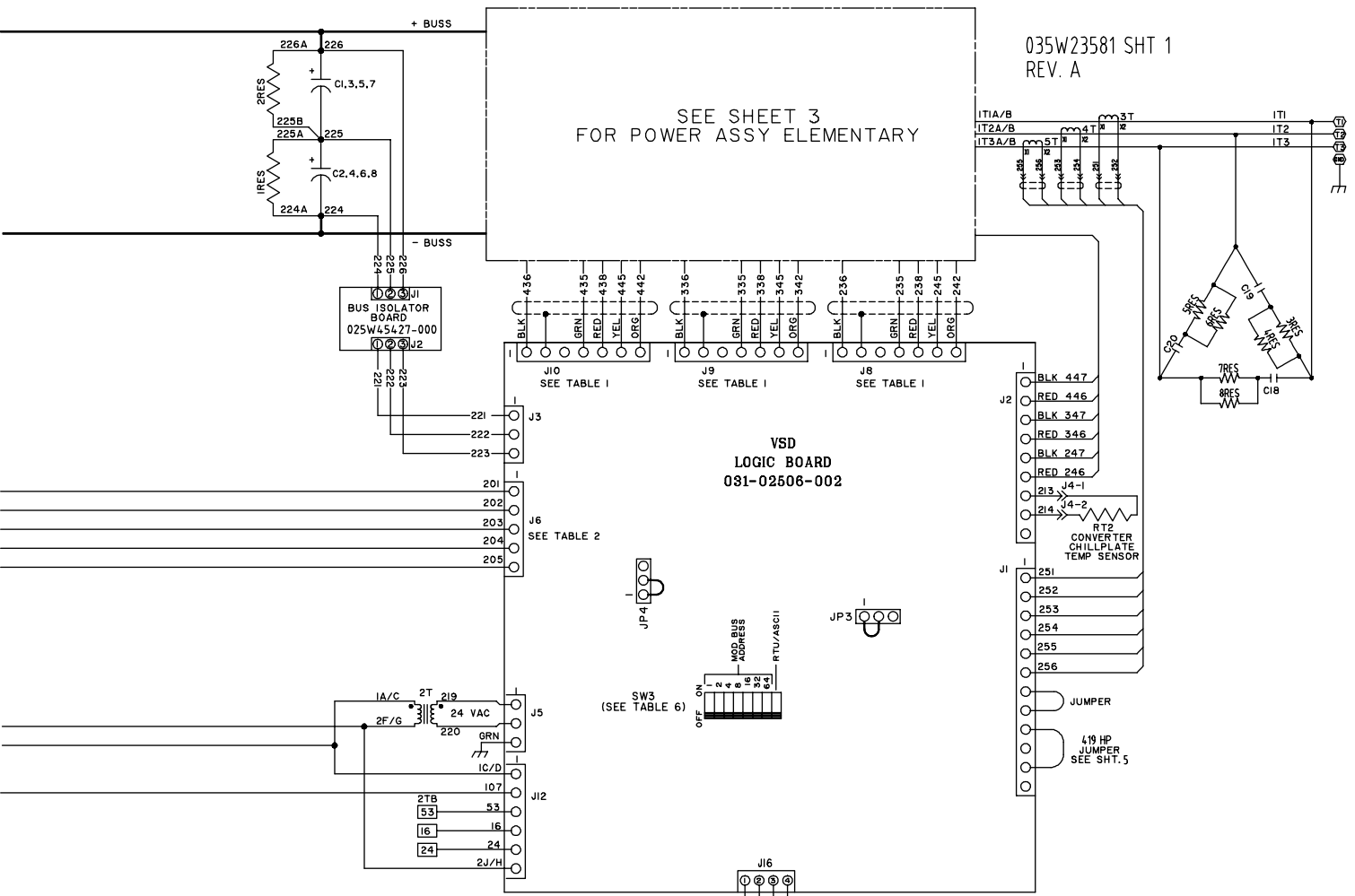

TABLE 1
HYPERLOGIC BOARD - J8, J9, J10 PINOUT

CONNECTOR PIN	FUNCTION
1	FAULT
2	GND/SHLD
3	+5V
4	UPPER PHASE
5	LOWER PHASE
6	SW, +7.5V
7	GND/SHLD

TABLE 2
HYPERLOGIC BOARD - J6 PINOUT

CONNECTOR PIN	FUNCTION
1	+5V FEED
2	PH LOSS OUT
3	PRECHG IN
4	SCRTRIG IN
5	+7.5V FEED

TABLE 6
SW3 POSITIONS

POSITION NUMBER	ASCII MODBUS PROTOCOL MODELS	RTU MODBUS PROTOCOL MODELS
1	ON	ON
2	OFF	OFF
4	OFF	OFF
8	OFF	OFF
16	OFF	OFF
32	OFF	OFF
64	OFF	OFF
RTU/ASCII	ON	OFF

LD22778

FIGURE 39 - ELEMENTARY WIRING DIAGRAM (400V AND 415V 419HP 50HZ)
FOR LVD MODELS ASIA DESIGN (CONT'D)

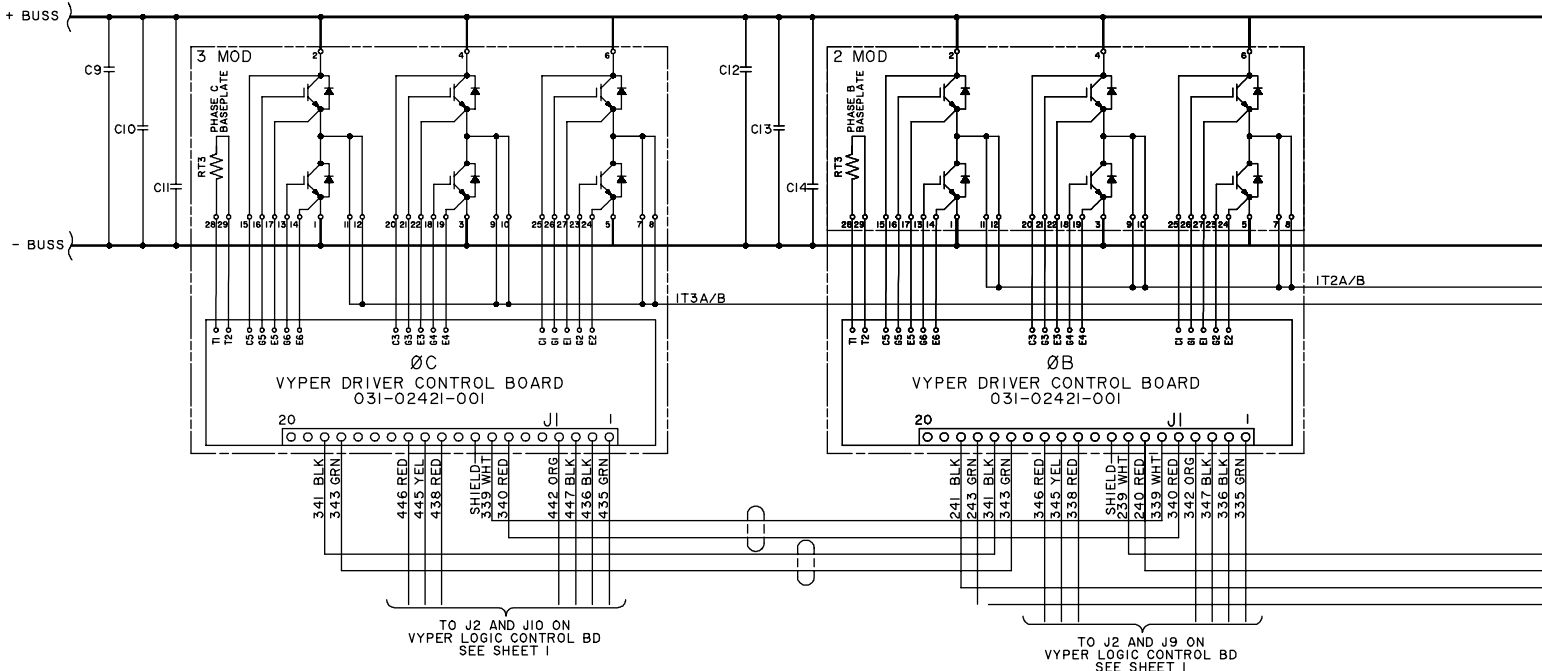

POWER ASSY ELEMENTARY

LD22779

**FIGURE 40 - POWER ASSEMBLY ELEMENTARY WIRING DIAGRAM (400V AND 415V 419HP 50HZ)
FOR LVD MODELS ASIA DESIGN**

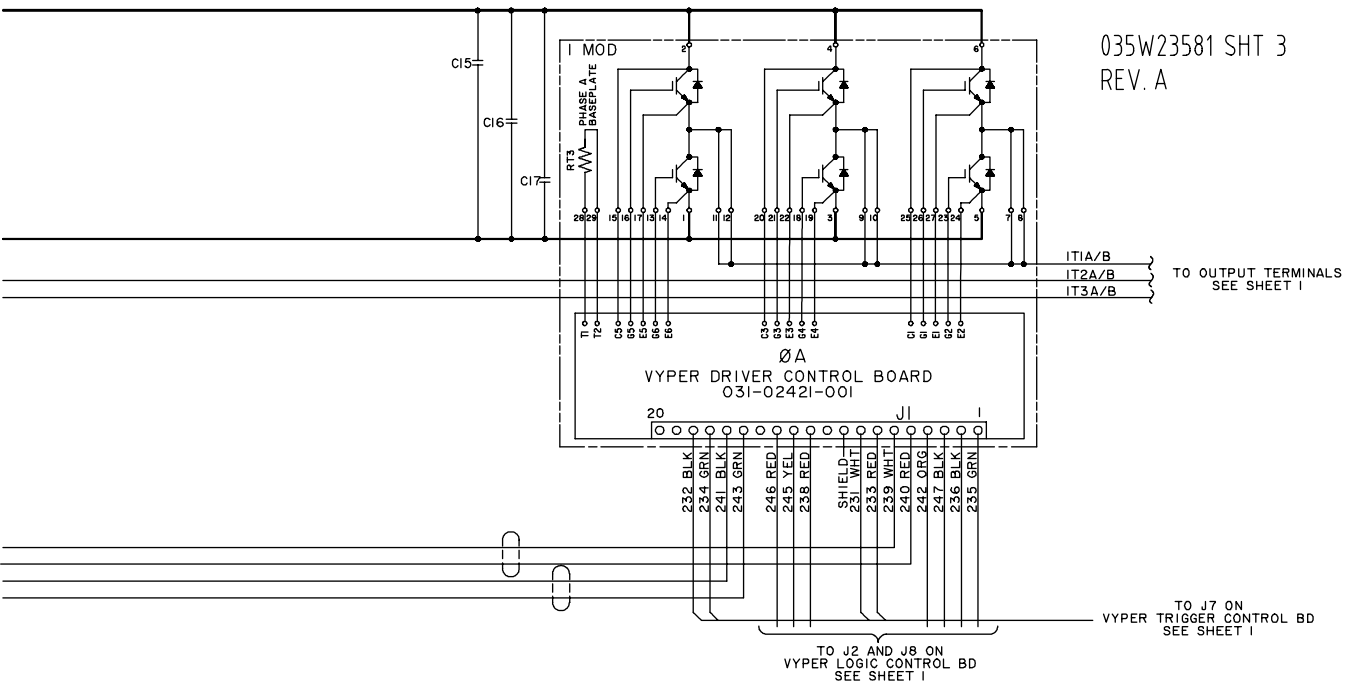
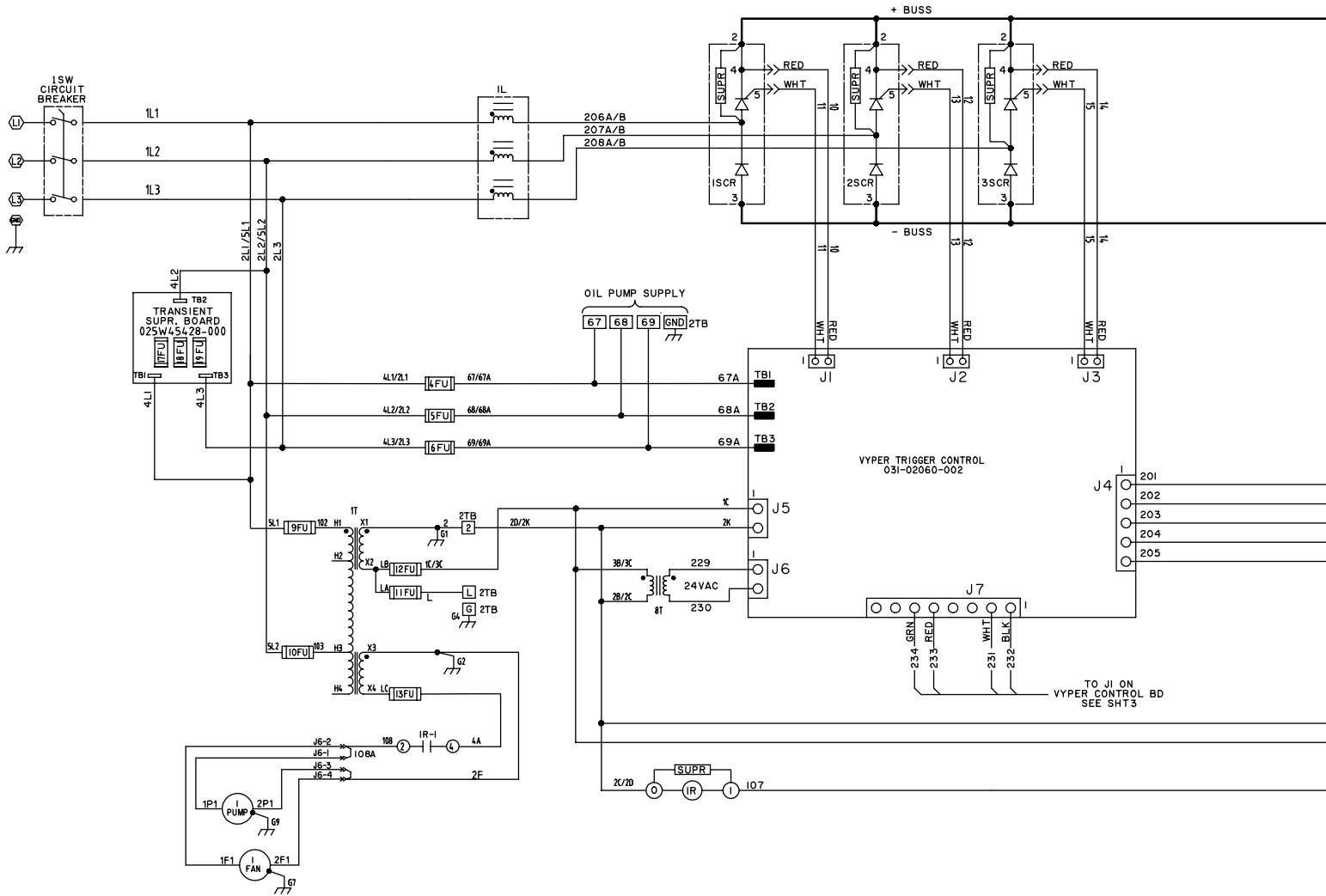

FIGURE 40 - POWER ASSEMBLY ELEMENTARY WIRING DIAGRAM (400V AND 415V 419HP 50HZ) FOR LVD MODELS ASIA DESIGN (CONT'D)



LD22781

**FIGURE 41 - ELEMENTARY WIRING DIAGRAM 400V 658HP AND 415V 704HP 50HZ)
FOR LVD MODELS ASIA DESIGN**

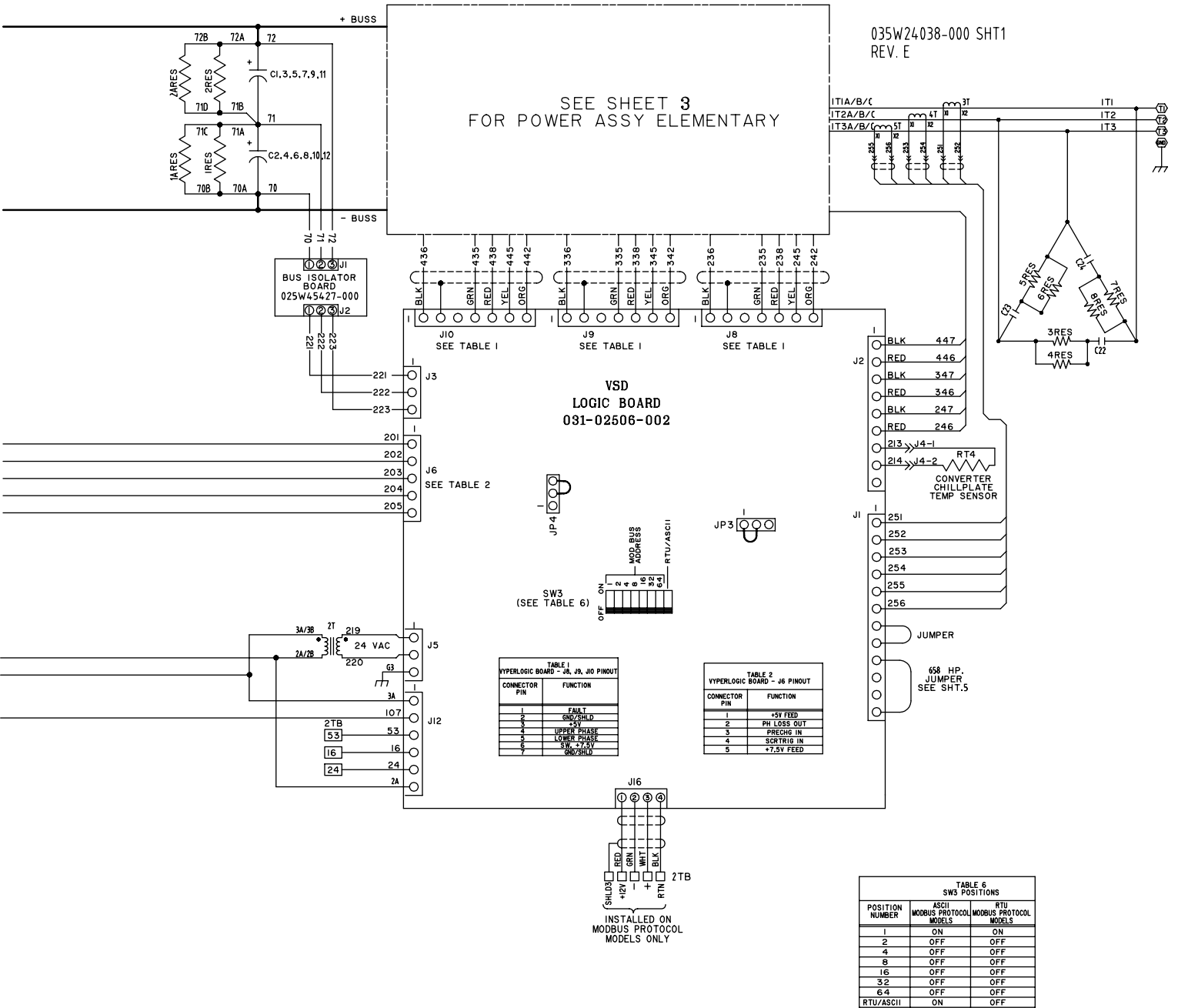
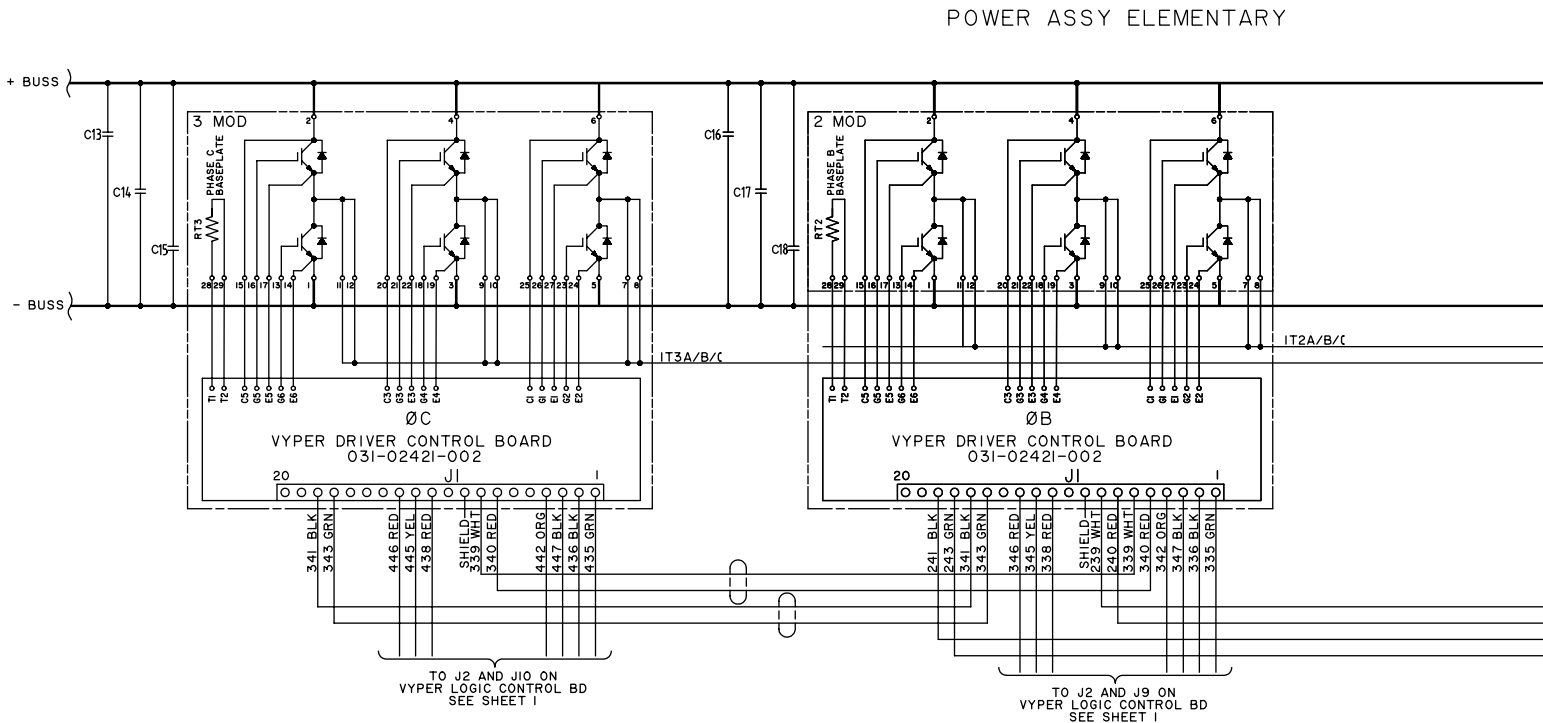
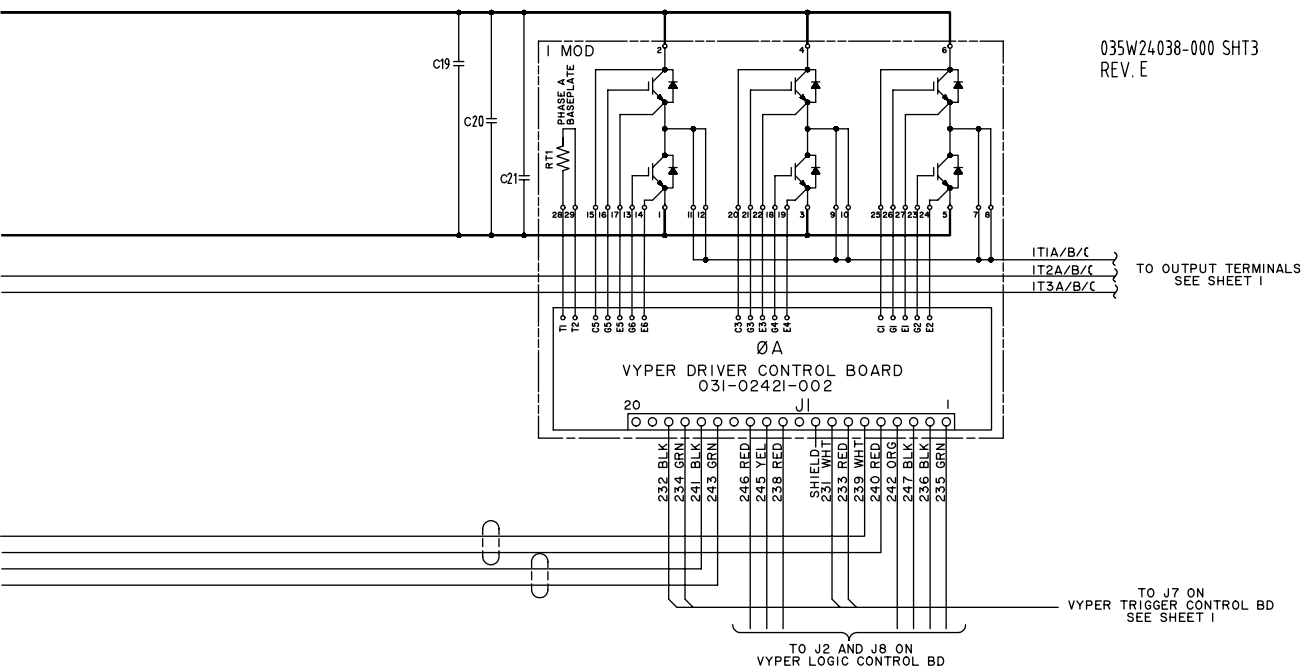

FIGURE 41 - ELEMENTARY WIRING DIAGRAM 400V 658HP AND 415V 704HP 50HZ)
FOR LVD MODELS ASIA DESIGN (CONT'D)



LD22783

**FIGURE 42 - POWER ASSEMBLY ELEMENTARY WIRING DIAGRAM (400V 658HP AND 415V 704HP 50HZ)
FOR LVD MODELS ASIA DESIGN**



LD22784

FIGURE 42 - POWER ASSEMBLY ELEMENTARY WIRING DIAGRAM (400V 658HP AND 415V 704HP 50HZ) FOR LVD MODELS ASIA DESIGN (CONT'D)

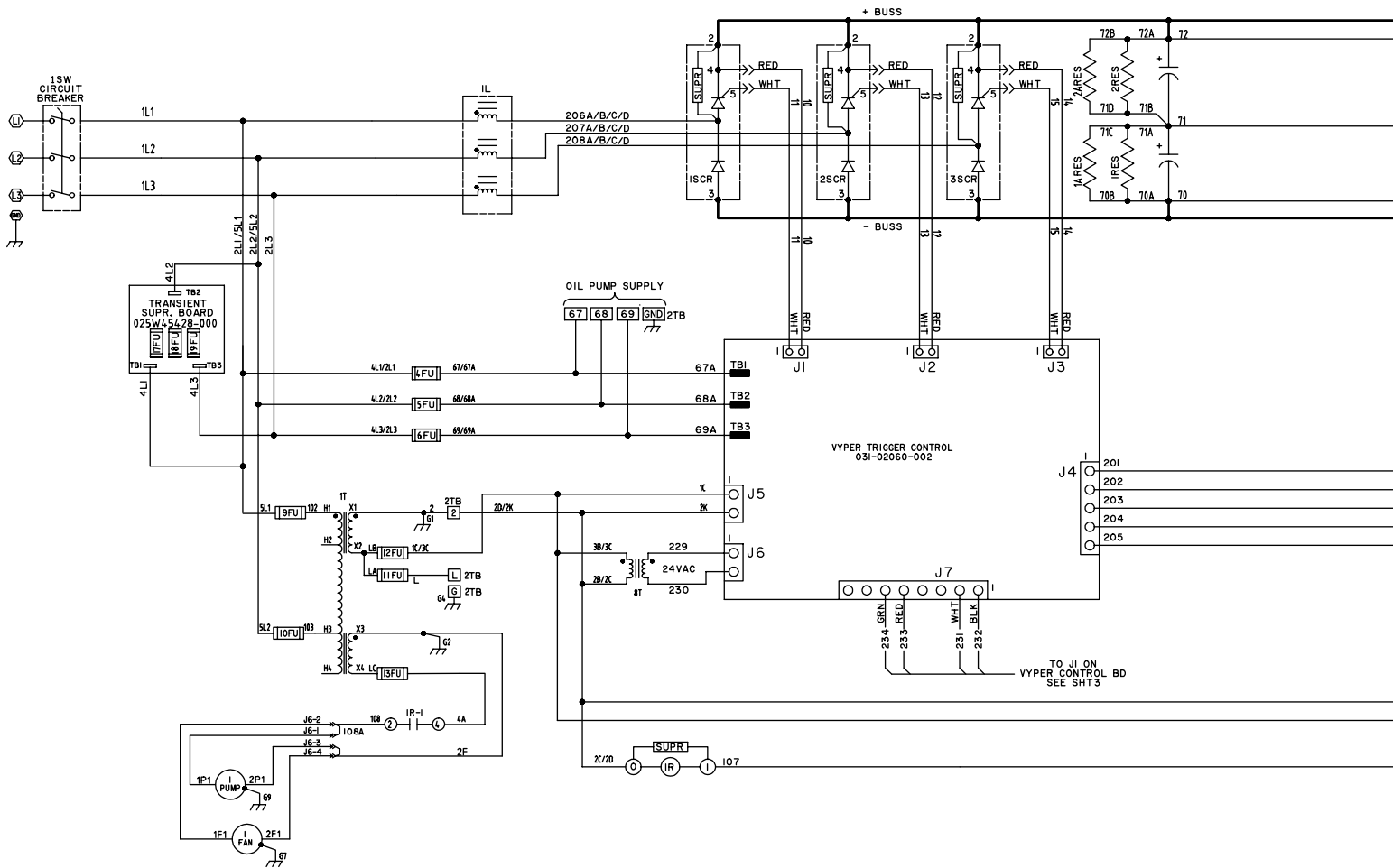

LD22785

FIGURE 43 - ELEMENTARY WIRING DIAGRAM 900 HP FOR LVD MODELS ASIA DESIGN

035W24039-000 SHT1
REV. E

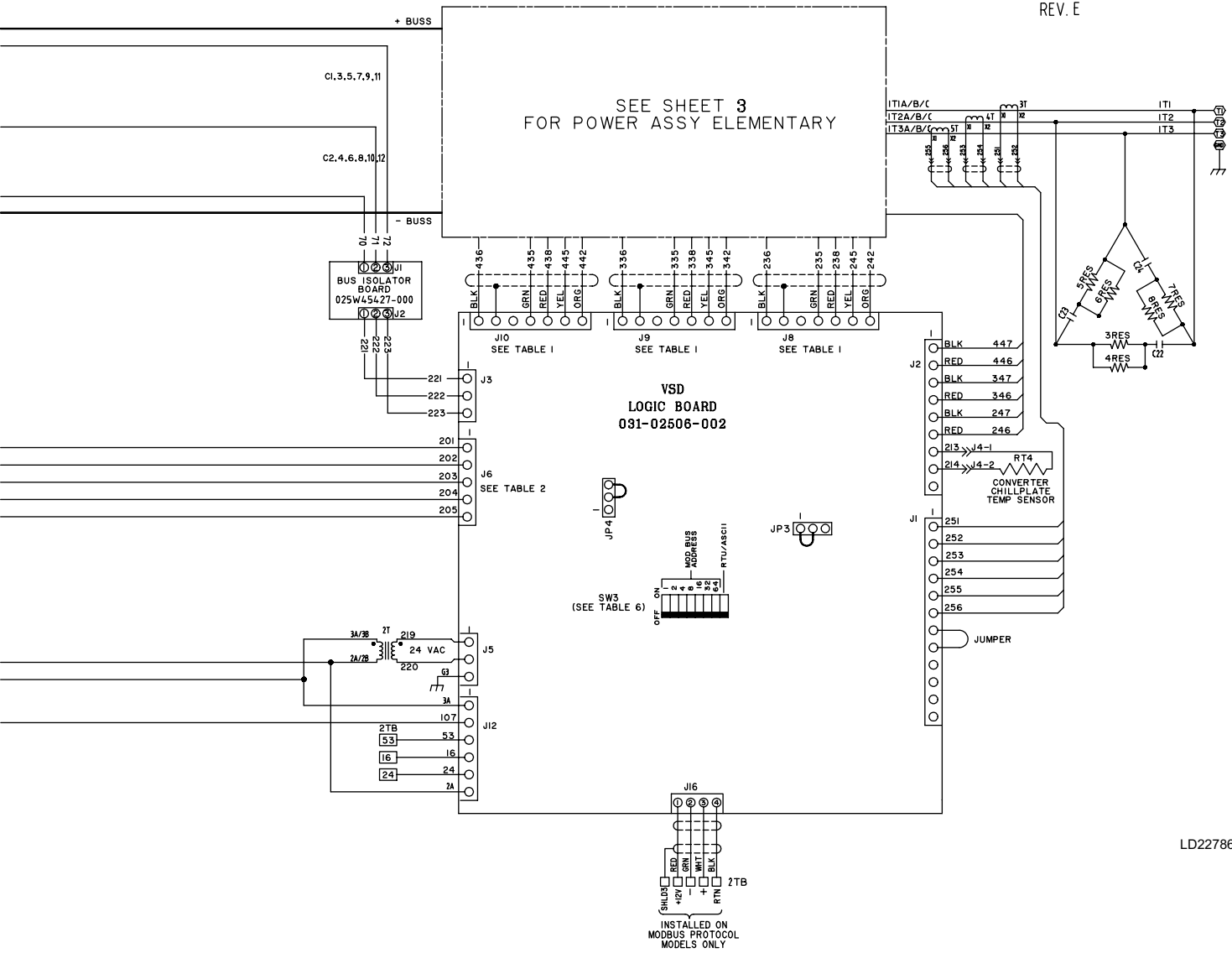

LD22786

TABLE 1
VYPERLOGIC BOARD - J8, J9, J10 PINOUT

CONNECTOR PIN	FUNCTION
1	FAULT
2	GN2/SHLD
3	+5V
4	UPPER PHASE
5	LOWER PHASE
6	SW, +7.5V
7	GN2/SHLD

TABLE 2
VYPERLOGIC BOARD - J6 PINOUT

CONNECTOR PIN	FUNCTION
1	+5V FEED
2	PH LOSS OUT
3	PRECHG IN
4	SCRTRIG IN
5	+7.5V FEED

TABLE 6
SW3 POSITIONS

POSITION NUMBER	ASCII MODBUS PROTOCOL MODELS	RTU MODBUS PROTOCOL MODELS
1	ON	ON
2	OFF	OFF
4	OFF	OFF
8	OFF	OFF
16	OFF	OFF
32	OFF	OFF
64	OFF	OFF
RTU/ASCII	ON	OFF

FIGURE 43 - ELEMENTARY WIRING DIAGRAM 90 HP FOR LVD MODELS ASIA DESIGN (CONT'D)

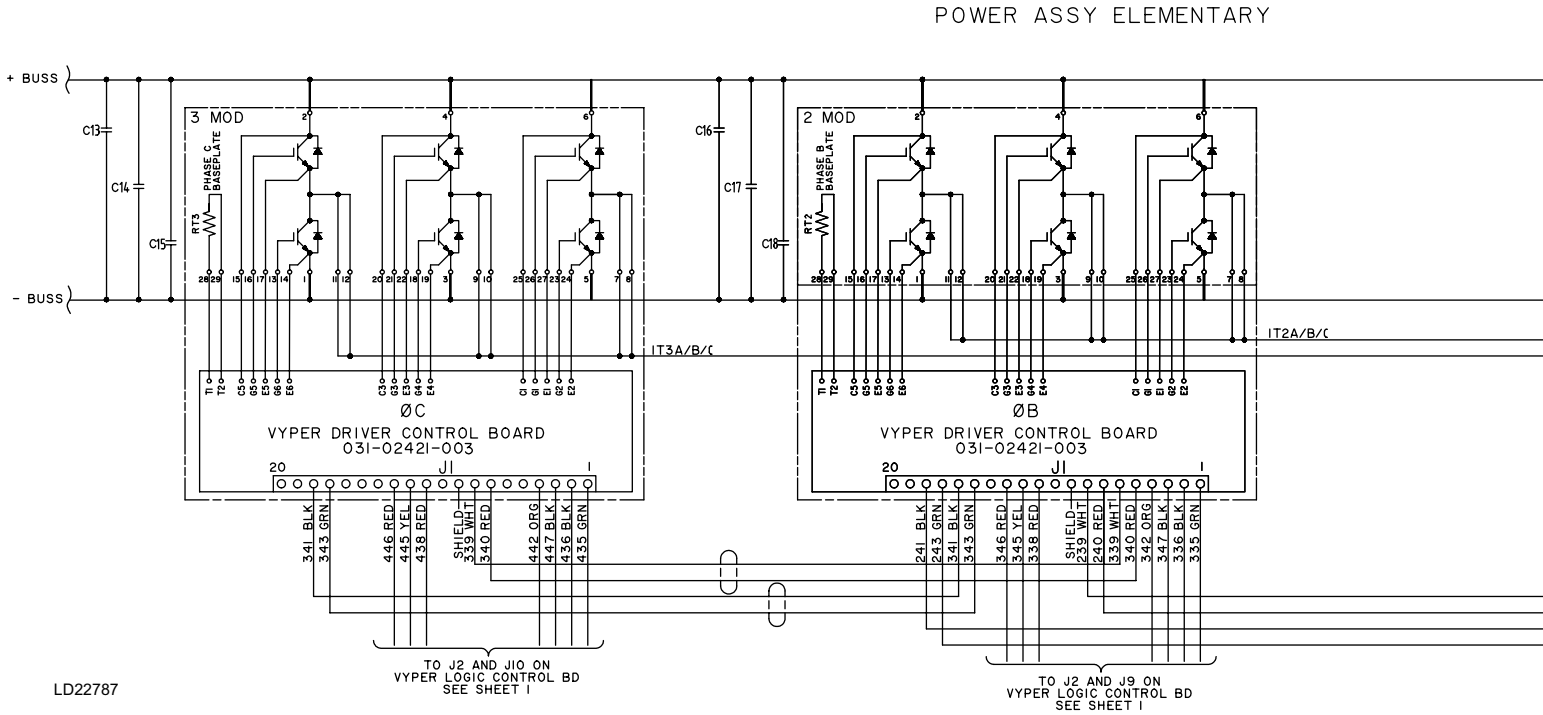

FIGURE 44 - POWER ASSEMBLY ELEMENTARY WIRING DIAGRAM 900 HP FOR LVD MODELS ASIA DESIGN

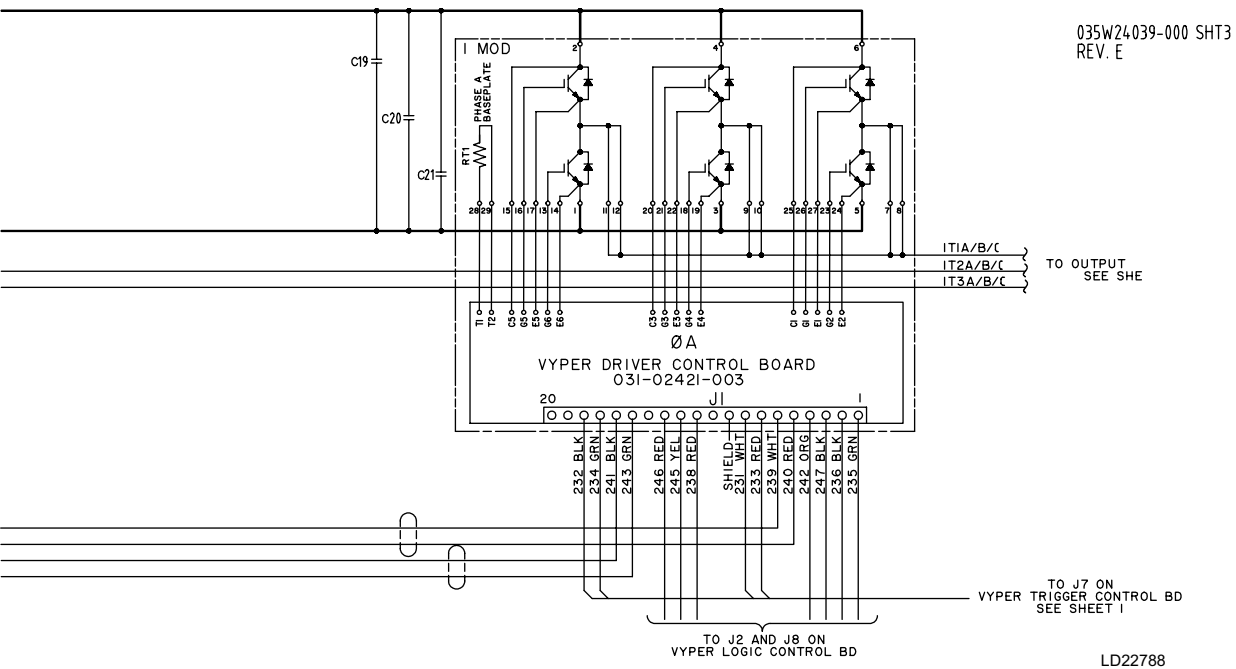

FIGURE 44 - POWER ASSEMBLY ELEMENTARY WIRING DIAGRAM 900 HP FOR LVD MODELS ASIA DESIGN (CONT'D)

THIS PAGE INTENTIONALLY LEFT BLANK.

SECTION 4 - OPTISPEED COMPRESSOR DRIVE CONTROL SYSTEM OVERVIEW

The OSCD control system can be connected to a Microcomputer Control Center or to an OptiView Control Center. Regardless of which control center is used each component performs the same function.

The OSCD control system is composed of various components located within both the Control Center and the OSCD. Thus integrating the Control Center with the OSCD. The OSCD system utilizes various microprocessors and Digital Signal Processors (DSPs) which are linked together through a network of parallel and serial communications links.

The Control Center

The Control Center contains two boards that act upon OSCD related information, the Microboard and the Adaptive Capacity Control board (ACC). The ACC board performs two major functions in the OSCD control system - (1) to act as a gateway for information flow between the Control Center and the OSCD. (2) To determine the optimum operating speed for maximum chiller system efficiency.

The ACC board acts as an information gateway for all data flowing between the OSCD and the Control Center. The ACC board communicates via a bi-directional serial port with the OSCD logic board (via J8 on the ACC board) and uni-directional serial port from the optional Filter logic board (via J9 on the ACC board) using a pair of shielded cables. Once the information is received by the ACC board, the information is then passed onto the Control Center via a software communication link. The Microcomputer Control Center communicates in a parallel fashion via two ribbon cables connecting the ACC board to the Microboard (J1 and J2 on the ACC board, *Figure 46 on page 100*). The OptiView Control Center communicates through a bi-directional serial port via a three wire shielded cable connecting the ACC board to the Microboard (J10 on the ACC board, *Figure 13*).

In order to achieve the most efficient operation of a centrifugal compressor, the speed of the compressor must be reduced to match the “lift” or “head” of the load. This “lift” or “head” is determined by the evaporator and condenser refrigerant pressures. However, if the compressor speed is reduced too much, the refrigerant gas will flow backwards through the compressor wheel causing the compressor to “surge”, an undesir-

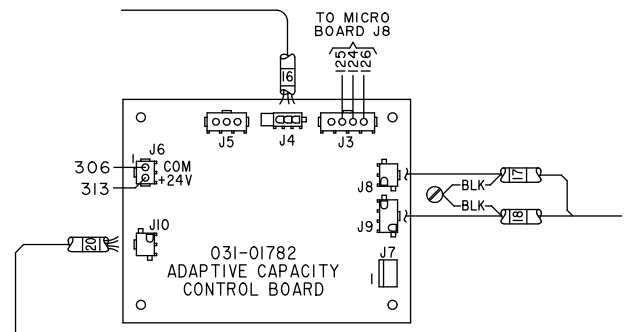

LD13118a

FIGURE 45 - ADAPTIVE CAPACITY CONTROL BOARD FOR OPTIVIEW CONTROL CENTER

able and extremely inefficient operating condition. Thus there exists one particular optimum operating speed (on the “edge” of surge) for a given head, which provides the optimum system efficiency. The compressor’s inletguide vanes, which are used in fixed speed applications to control the amount of refrigerant gas flowing through the compressor, are controlled together with the compressor speed on an OSCD chiller system, to obtain the required chilled water temperature while simultaneously requiring minimum power from the AC line.

The ACC board automatically generates its own “Adaptive” three-dimensional surge surface map while the chiller system is in operation. This “Adaptive” operation is accomplished through the use of a patented surge detection algorithm. The novel surge detection system utilizes pressure information obtained from the chiller’s two pressure transducers or the OSCD’s instantaneous power output to determine if the system is in “surge”. Thus the adaptive system permits construction of a customized compressor map for each individual chiller system.

Benefits of this new adaptive system include: (1) a customized compressor map for each chiller which eliminates inefficient operation due to the safety margin built into the previous designs to compensate for compressor manufacturing tolerances (2) the ability to update the system’s surge surface as the unit ages and (3) automatic updating of the compressor map if changes in refrigerant are implemented at a later date.

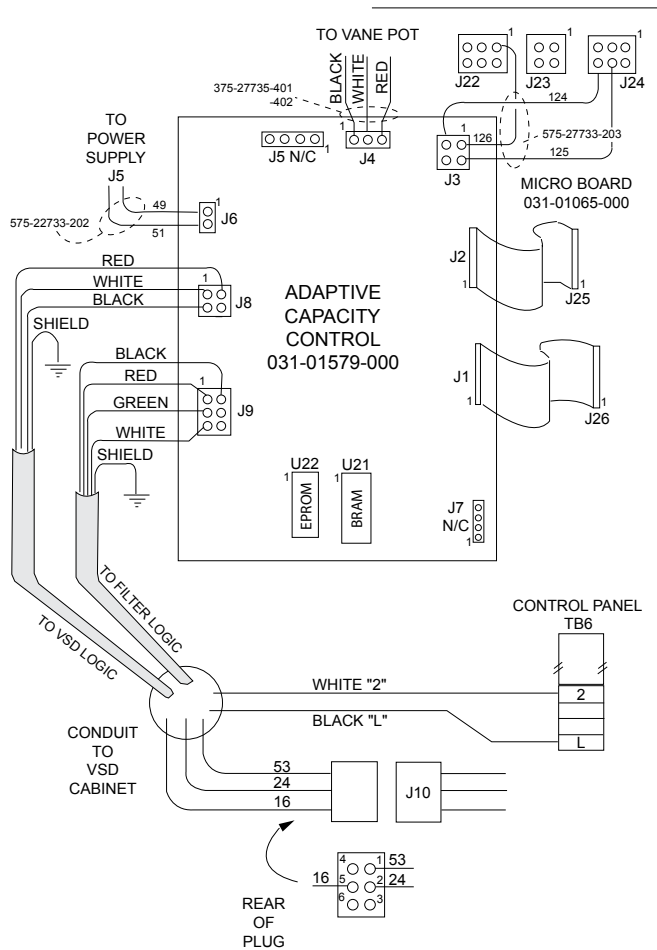

FIGURE 46 - ADAPTIVE CAPACITY CONTROL BOARD

OptiSpeed Drive Logic Control Board

Within the OSCD enclosure, the OSCD logic board and optional Filter logic board are interconnected via a 16-position ribbon cable. The Filter Logic board derives its control power from the OSCD Logic board over this ribbon cable. In addition, various logic level “handshake” signals convey the operating status of the OSCD to the Filter and vice versa over this cable. Finally, the cable includes a unidirectional serial communications link, which permits the transmission of a limited amount of data, such as the run command, from the OSCD to the optional Harmonic Filter.

The OSCD Logic board performs numerous functions, control of the OSCD’s cooling fans and pumps, when to pre-charge the bus capacitors, and generates the PWM.

- The cooling fans and pumps are commanded to turn on whenever the OSCD is commanded to run. They will turn off when the drive is commanded to stop. If the OSCD is shutdown due to a high-temperature condition, then the fans and pumps will continue to run until the value of the high-temperature has dropped below a specified value. The cooling fans and pumps will also run if the J2 connector is removed.
- The OSCD Logic board sends a command signal to the SCR gate driver board to precharge the bus capacitors. For pre-charge to become active J6 Pin 3 must be low, and J6 Pin 5 must be at 7.5 VDC.
- The PWM generation is required so that the output of the OSCD will provide to the motor the proper voltage for a given output frequency. The PWM generation is sent to the IGBT gate driver board via J8, J9, and J10.

The OSCD Logic board also determines shutdown conditions by monitoring the three phases of motor current, heatsink temperature, baseplate temperature, internal ambient temperature, and the DC Link voltage.

- The output motor current is monitored by the current transformers mounted in the center of the drive. They are connected to the OSCD logic board on J6.
- The heatsink temperature is monitored by a thermistor mounted on the same side of the chill plate as the SCR/Diode blocks. This sensor is connected to the OSCD logic board on J2.
- The baseplate temperature is monitored by a thermistor mounted inside each IGBT module. Any one of the thermistors can cause an over temperature fault. The thermistor/thermistors are connected to the OSCD logic board via the IGBT gate drive board and then onto J2.
- The internal ambient temperature is monitored by a thermistor mounted on the OSCD Logic board.
- The DC Bus voltage is monitored by the DC link isolator board. It is connected to the OSCD logic board on J3.

OptiSpeed Harmonic Filter Logic Control Board

The optional Harmonic Filter logic board determines when to precharge the filter power unit, when to switch the IGBT's in the filter power unit, and collects data to determine power calculations. Data such as input line voltage, filter DC bus voltage, output current of the filter power unit, and temperature of the filter power unit IGBT's are collected and sent to the Control Center. This data is also used by the filter logic board to determine if a shutdown is required.

- The Harmonic Filter Logic board sends a command signal to the pre-charge contactor to become active J4 Pin 1 must be 115 VAC
- The Harmonic Filter Logic board sends a command signal to the supply contactor to become active J4 Pin 3 must be 115 VAC
- It turns on and off the Harmonic Filter IGBT's via J2
- It sends communications to the ACC board via J8.

The Harmonic Filter Logic board also determines shutdown conditions by monitoring the two phases of input current, two phases of filter output current, baseplate temperature of the harmonic filter IGBT, input line voltage, and the DC Link voltage.

- The input current is monitored by the current transformers mounted near the filter inductor. They are connected to the filter logic board on J3 pins 1-4.
- The filter current is monitored by the DC current transformers mounted between the wires to filter inductor and the filter's IGBT module. They are connected to the filter logic board on J3 pins 5-7 and 10-12.
- The baseplate temperature is monitored by a thermistor mounted inside the harmonic filter IGBT module. This sensor is connected to the filter logic board via the IGBT gate drive board and then onto J6 pins 1 and 2.
- The input voltage is monitored by the AC line voltage isolator board and is connected to the filter logic board on J5 pins 1-4. Measuring AC voltage from pins 1-2, 2-3, 3-1, should have a value of 5.2 VAC with a 460 VAC line voltage.
- The DC Bus voltage is monitored by the DC link isolator board. It is connected to the filter logic board on J5 pins 5-7.

Microcomputer Control Panel VSD Related Keypad Functions

Refer to *Service Model TM (Variable Speed Drive) (Form 160.00-M1)* for related keypad functions. Some of the displayed data in this form is different from the 160.00-M1.

Under the Options Key – the following changes will be displayed:

VSD PHASE A INVERTER HEATSINK TEMP = ___°F.

VSD PHASE B INVERTER HEATSINK TEMP = ___°F.

VSD PHASE C INVERTER HEATSINK TEMP = ___°F.

These three temperature values are replaced with:

VSD BASEPLATE TEMP = ___°F.

for the 270, 292, 351 385, and 424 Hp drive. The 419, 503 and 608 Hp drive will still display 3 phases of Baseplate temperature. When the Filter is present the following data will be changed.

FILTER HEATSINK TEMP = ____°F.

This temperature data will now be called.

FILTER BASEPLATE TEMP = ____°F.

The names for the above data were changed because the temperature sensor is now inside the IGBT module instead on the chill plate where the IGBT's are mounted. This new sensor gives a better indication of true temperature of the IGBT module.

OptiView Control Panel VSD Functions

Refer to the specific OptiViewControl Panel service book for detailed information. All of the OSCD related information is contained under the Motor and Compressor Screens.

SECTION 5 - VSD ADAPTIVE CAPACITY CONTROL

The YORK OptiSpeed Compressor Drive utilizes a different approach to speed reduction compared to earlier variable speed products. There is no preprogrammed surge map – the YORK adaptive system experiments with the speed and vanes to find the optimum speed for any given condition. It does not always encounter a “Surge” in the process, but when it does, the Adaptive Capacity Control (ACC) stores into memory, the conditions surrounding the Surge, and therefore remembers to avoid the stored operating point anytime in the future. This sounds a bit mysterious, but the process is really quite simple. Once you have an understanding of the steps involved, you will be able to watch the chiller adjust itself to different conditions, and understand exactly why it is performing in the manner it does.

Early versions of the ACC software required that the drive always start and run up to full speed. ACC software starting with version C.ACC.01.04 applies a slow ramp up of the drive speed. This new software lowers the peak current demand from the drive during start up, saves additional energy, and reduces the possibility of the chiller running in a stall condition.

The new software will ramp the drive speed up to 30 Hz quickly, and then takes 5 minutes to ramp up to 60 Hz. During this slow ramp up period the vanes will open to meet the cooling demand. If the leaving chilled liquid temperature is within +0.5 or lower of the leaving chilled liquid temperature setpoint, then the drive speed will stop increasing and start to search for a surge map point. On extremely hot days the chiller will surge during the slow ramp period. The new software has a method to limit the surging. If 2 surges were to occur during the slow ramp period, then the speed of the drive will increase quickly to 60 Hz.

All versions of software require that two conditions be met for speed reduction to occur. These two conditions are:

Setpoint Requirements

The leaving chilled liquid temperature must be within +0.5 °F or lower from the leaving chilled liquid temperature setpoint. Speed reduction will not occur until the leaving chilled liquid temperature reaches this range.

Stability Requirements

The leaving chilled liquid temperature must be stable, with the vanes not driving open or closed to maintain the temperature. Lack of stability will be evidenced by the vanes hunting, the leaving chilled liquid temperature varying, and the green LED on the ACC board will be on, to indicate instability. Once the above conditions

are met, the ACC board may begin to lower the speed of the compressor motor 1/10 of a hertz at a time. As the ACC board lowers the speed, the leaving chilled liquid temperature will begin to creep up, due to the reduction in speed. As this occurs, the control center will begin to open the vanes slightly, just enough to maintain the leaving chilled liquid temperature within +/- 0.5°F of the leaving chilled liquid temperature setpoint. The ACC board will continue to lower speed, with the leaving chilled liquid temperature control in turn driving the vanes to a more open position. This process will continue until one of three following situations occurs.

Full Open Vane Operation

Once the vanes reach the full open position, the ACC board knows it can no longer reduce speed and maintain the leaving chilled liquid temperature setpoint. The ACC board will maintain operation at this point, with the vanes full open, and the speed at the last point reached when the vanes hit 100%. If there is an increase in load while at this point, the ACC board will increase speed until the vanes are closed to 95% of open. The ACC board will then be allowed to continue to reduce speed again.

Effects of Surge

If in the process of reducing speed and opening vanes the compressor should surge, the ACC board will boost the speed up by 0.8 Hz. The ACC board will store in memory a value that is (condenser pressure/evaporator pressure) - 1, the vane position present at the time of the surge, and the speed of the drive. The value for (condenser pressure/evaporator pressure) - 1 is displayed as Delta P/P on the Control Panel. The ACC board will then know not to reduce speed this low again, if the same delta pressure, and the vane position conditions are encountered again in the future. As the

chiller encounters more delta pressure and vane position combinations, which result in surge, it will store more points, and eventually this storing of points creates a “Surge Map”.

Surges may be detected in two ways, by monitoring the pressure differential across the compressor, or by monitoring the compressor motor current. Either detection will light the Red LED on the ACC board, indicating a surge was detected. The chiller may surge 6 to 8 times before the ACC board can raise the speed enough to get the chiller back out of surge. Each surge is counted on the surge counter, which may be called up on the control center. This surge counter will always display the total number of surges encountered by the chiller as determined by the ACC board, but not the total number of points contained in the surge map.

Surging which occurs at fixed speed will increment the surge counter as well, but only surges that occur when speed reduction is possible are recorded in the surge map. We know of one chiller, which ran in continuous surge for two weeks due to a cooling tower problem. The customer’s fixed speed chiller was surging continuously for 2 weeks also. During this time, the VSD surge counter accumulated over 18,000 surges.

Drive Not Slowing Down

The ACC board may begin the process of reducing speed, but may stop speed reduction prematurely if instability is encountered. This is the same instability discussed as one of the two conditions which must be met to begin reducing speed initially (See “Stability Requirements”). Once the system again becomes unstable, no additional speed reduction can occur. The most common causes for instability are:

- Rapid changes to chilled or condenser liquid flow. (Variable speed pumps may not work well)
- Valves on air-handler coils closing rapidly causes changes in heat-load.
- Extremely short chilled liquid loop.
- Parallel chiller with poor control is causing temperature variations.
- Parallel chiller with poor control of chilled or condenser water flows.
- Dirty condenser tubes or high condenser liquid temperature.
- Chillers with very light loads.
- Liquid level control not working properly.

If you experience a problem with an OSCD not reducing speed at all, make certain the system is not in manual speed control, or locked into fixed speed. Refer to the section on “Manual Speed Control” in the “Frequently Asked Questions” section. Also, make certain the wiring at J3 on the ACC board is properly connected per the wiring diagram in this same manual. Either situation will cause the chiller to maintain full speed. If the OSCD is reducing speed, but not running as slow as you expect it should, it is likely because it is either in an unstable condition, or running just above a mapped surge point.

As described above, the chiller must achieve stability, which is evidenced by the Green LED being extinguished. Instability will cause the Green LED to be illuminated. To determine if the chiller is running just above a surge point, switch the system to manual speed control, and force the speed lower by one or two hertz. If you encounter a surge, this explains why the chiller would not reduce speed. If you find the chiller does drop speed without surging, instability was likely preventing further speed reduction.

Drive Does Not Respond To Chiller Surging

The ACC control uses information from the condenser and evaporator pressure transducers to determine if the chillers has surged. If the chiller is surging and the speed of the drive is not increasing, then the wiring to the ACC board on J3 should be verified. Many times where an OSCD is retrofitted to an existing chiller the wiring to J3 is forgotten. A few new chillers with OSCD’s have the wiring to the J3 of the ACC or at the control center microboard wired incorrectly.

Stability Limit Adjustment

Stability Limit Adjustment allows the system to properly function with larger amounts of temperature instability. Refer to *Service (Control Panel) Model YT, (Centrifugal) (Form 160.55.M1)*, or *Service (Control Panel) Model YK, (Centrifugal) (Form 160.54.M1)* for the location of this parameter. Stability Limit has a range of 1000-7000. Although the leaving chilled liquid temperature Setpoint Requirement is satisfied, the Stability Requirement must also be satisfied. When the Stability Limit is adjusted to a value of 1000, then the leaving chilled liquid temperature can not change more than 0.067°F/second. When the Stability Limit is adjusted to a value of 6999, the leaving chilled liquid temperature can not change more than 0.47°F/second. If you are having a problem with a lightly load chiller and the temperature is not stable, then adjust the Stability Limit to 7000. The value of 7000 will disable this parameter.

Surge Margin Adjustment

Surge Margin Adjustment allows the surge map to increase the frequency portion of the surge map. This parameter is rarely used, and it decreases the efficiency of the OSCD chiller system. Some people believe that this value can help with a stall condition. This is not true. Actually, increasing the Surge Margin Adjustment will cause the stall condition to be worse. Increasing the speed of the compressor will cause the vane to close even more and increase the stall noise and vibration.

Software Version Changes

- Software version C.ACC.01.03 improved the communications between the ACC board and the OSCD logic board.

- Software version C.ACC.01.03a made additional improvements to the communications between the ACC board and the OSCD logic board.
- Software version C.ACC.01.04 added a slow ramp when the chiller is started. This version requires that a pulldown demand limit be set to 80% for 5 minutes.
- Software version C.ACC.01.05 changes how the ACC control will detect a surge. This version is required for new compressor designs. This software is backwards compatible with older compressors as well.

THIS PAGE INTENTIONALLY LEFT BLANK.

SECTION 6 - SHUTDOWN MESSAGES

SAFETY SHUTDOWNS

General Information

The Shutdowns are organized in alphabetical order based on the OptiView Control Center messages. The Microcomputer Control Center messages are also included under these headings.

Whenever a Safety Shutdown is generated by the OSCD or Harmonic Filter Logic Board, a series of events will occur.

- If the chiller is not running at the time of the shutdown, the OSCD Logic Board will not turn on the IGBT gate drivers.
- The K1 relay on the OSCD logic board will de-energize causing an open circuit between J12-3 wire #53 and J12-4 wire #16. This action will indicate to the Control Center that the OSCD has shutdown. The K1 relay will remain de-energized until the cause of the shutdown has been corrected.
- If the chiller is running at the time of the shutdown, the Control Center will start a coastdown period (150 seconds for centrifugal chillers).

The message “VSD Shutdown - Requesting Fault Data”...will be displayed when the Control Center is requesting the fault data from the OSCD.

The OSCD or Harmonic Filter Logic Board will send a shutdown code via the serial communications link to the ACC board and then to the Control Center. The Micro Board will interpret the shutdown code, and display a shutdown message on the display of the Control Center.

After the coastdown period has timed out, the chiller may be restarted, if the shutdown is no longer active. Place the Compressor Switch in the Stop/Reset position, and then into the Start position and release. The chiller will start if no faults are active.

Motor or Starter - Current Imbalance

Message: MOTOR OR STARTER – CURRENT IMBALANCE

The OSCD logic board generates this shutdown. This shutdown will become active when the highest of the three motor currents exceeds 80% of the programmed FLA. After these conditions are met, if any one phase of motor current exceeds 30% of the average current for 45 seconds, a Safety shutdown will occur. Review the following example.

If

current in the A phase = 200A

current in the B phase = 200A

current in the C phase = 118A

Then

$$I_{AVE} = \frac{200 + 200 + 118}{3}$$

$$I_{AVE} = 173A$$

$$I_{ACCEPTABLE} = 173 * \pm 30\% = 121A, 225A$$

Therefore

Since phase “C” current = 118A which is less than the acceptable 121A, the chiller would shutdown if this imbalance exists for 45 seconds.

Possible Problems:

- Verify that all six of the gate driver LED’s are lit.
- Verify that the output CT’s are reading current correctly.

VSD - 105 % Motor Current Overload**Message: 105% MOTOR CURRENT OVERLOAD**

The OSCD logic board generates this shutdown, by reading the current from the 3 output current transformers. The shutdown is generated when the OSCD logic board has detected that the highest of the three output phase currents has exceeded 105% of the programmed 100% full load amps (FLA) value for more than 40 seconds. The 100% FLA setpoint is determined by adjustment of the FLA trimpot on the OSCD logic board. This shutdown requires a manual reset via the Reset push-button on the OSCD logic board.

Possible Problems:

- FLA value not properly set for the application.
- High condenser pressure.
- Too much refrigerant in the chiller causing carry over.
- Refrigerant level sensor or system not working properly.

VSD - High Converter Heatsink Temperature**Message: HIGH CONVERTER HEATSINK TEMP**

A thermistor sensor is positioned on the bottom of the copper chill plate where the SCR/Diode modules are located. The OSCD logic board reads all of the thermistor values and determines if any thermistor value exceeds the shutdown value; if it does, a shutdown will occur. The cooling fans and coolant pump on the OSCD will continue to run after the shutdown, until the thermistor temperature has dropped to below 160°F (71°C).

See "Possible Problems" under fault message "*VSD - High Phase (X) Inverter Baseplate Temperature*" on page 108.

VSD - High Inverter Baseplate Temperature (270, 292, 351, and 424 Hp drive only)**Message: HIGH INVERTER BASEPLATE TEMPERATURE FLT**

A thermistor sensor is located inside the IGBT Module on the OSCD power unit. The OSCD logic board reads all of the thermistor values and determines if any thermistor value exceeds the shutdown value; if it does, a shutdown will occur. The cooling fans and coolant pump on the OSCD will continue to run after the shutdown, until the thermistor temperature has dropped to below 165°F (74°C).

See "Possible Problems" under fault message "*VSD - High Phase (X) Inverter Baseplate Temperature*" on page 108.

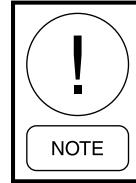
VSD - High Phase (X) Inverter Baseplate Temperature**Message: HIGH PHASE (X) BASEPLATE TEMPERATURE FAULT**

The X will indicate the phase that the high temperature has occurred.

A thermistor sensor is located inside each IGBT Module on the OSCD power unit. The OSCD logic board reads all of the thermistor values and determines if any thermistor value exceeds the shutdown value; if it does, a shutdown will occur. The cooling fans and coolant pump on the OSCD will continue to run after the shutdown, until the thermistor temperature has dropped to below the reset value. These values are determined by the drive HP rating of the OSCD, and are shown in the table below.

DRIVE HP RATING	SHUTDOWN VALUE	RESET VALUE
385, 419, 503, 608 (575 VAC)	175°F (79°C)	165°F (74°C)
546, 575	190°F (88°C)	175°F (79°C)
608 (400 VAC), 658, 704, 900	196°F (91°C)	165°F (74°C)

Possible Problems:

- Improper coolant level for the drive.
- Leaks within the cooling system.
- Shipping coolant not drained at start-up.
- Clogged chill plate.
- Low condenser water flow.
- High condenser water temperature.
- Dirty tube and shell heat exchanger.
- No thermal grease used on the IGBT, or Diode/SCR module.
- Failure of the coolant pump.
- Failure of a fuse for the coolant pump.
- Improper torque used during the mounting of the IGBT, or Diode/SCR module.

VSD - Precharge Lockout

Message: **PRE-CHARGE FAULT LOCKOUT**

If the OSCD fails to meet the pre-charge criteria (refer to pre-charge faults), then the pre-charge circuit will wait for a period of 10 seconds. During which time the unit's cooling fans and coolant pump shall remain energized in order to cool the input SCR's. Following this 10-second cool-down period pre-charge shall again be initiated. The unit shall attempt to meet the pre-charge criteria three consecutive times. If the OSCD fails to meet the pre-charge criteria on three consecutive tries, the OSCD will shut down, lockout, and display this message.

Harmonic Filter - High Baseplate Temperature

Message: **HIGH FILTER BASEPLATE TEMPERATURE FAULT**

A thermistor sensor is located inside the IGBT Module on the harmonic filter power unit. If at anytime this thermistor detects a temperature higher then the shutdown threshold as determined by the harmonic filter logic board. Refer to the chart below for the shutdown threshold value.

DRIVE HP RATING	SHUTDOWN VALUE
270, 292, 351	175°F (79°C)
385, 419,424,503,608	190°F (88°C)

Possible Problems:

- Improper coolant level for the drive.
- Shipping coolant not drained at start-up.
- Clogged chill plate.
- Low condenser water flow.
- Dirty tube and shell heat exchanger.
- Failure of the coolant pump.
- No thermal grease used on the IGBT module.

Harmonic Filter - High Total Demand Distortion

Message: **FLTR HIGH TDD FLT**

The control center determines this shutdown by using data supplied from the harmonic filter logic board. This shutdown indicates that the filter is not operating correctly or the input voltage to the OSCD/filter system is not sinusoidal. This shutdown will occur if the Total Demand Distortion (TDD) in any one phase exceeds 25% continuously for 45 seconds. TDD is an acronym for Total Demand Distortion, a term defined by the IEEE Std 519-1992 standard as "the total root - sum - square harmonic current distortion, in percent of the maximum demand load current (15 or 30 min demand)". In the filter option supplied by York, the displayed TDD is the total RMS value of the harmonic current supplied by the power mains to the OSCD system divided by the FLA of the OSCD, in percent. The harmonic filter option was designed to provide an input current TDD level of 8% or less for the OSCD system. A standard OSCD less the optional filter typically has an input current TDD level on the order of 28 - 30%.

Possible Problems:

- Failure of the harmonic filter logic board.
- Wiring error or failure between the harmonic filter logic board and the harmonic filter power unit.
- Verify that the 6 LED's are lit on the harmonic filter IGBT gate driver board. If one LED is not lit, then the IGBT gate driver board and IGBT module needs to be replaced.
- Ensure that all wiring to the filter logic board and the filter IGBT module are properly phased.

CYCLING SHUTDOWNS

General Information

The Shutdowns are organized in alphabetical order based on the OptiView Control Center Panel messages. The Microcomputer Control Panel messages are also included under these headings.

Whenever the OSCD or Harmonic Filter Logic Board generates a Cycling Shutdown a series of events will occur.

- If the chiller is not running at the time of the shutdown, the OSCD Logic Board will not turn on the IGBT gate drivers.
- The K1 relay on the OSCD logic board will deenergize causing an open circuit between J12-3 wire #53 and J12-4 wire #16. This action will indicate to the Control Center that the OSCD has shutdown. The K1 relay will remain deenergized until the cause of the shutdown has been corrected.
- If the chiller is running at the time of the shutdown, the Control Center will start a coastdown period (150 seconds for centrifugal chillers).
- The message “VSD Shutdown - Requesting Fault Data”...will be displayed when the Control Center is requesting the fault data from the OSCD.
- The OSCD or Harmonic Filter Logic Board will send a shutdown code via the serial communications link to the Adaptive Capacity Control Board and then to the Control Center. The Micro Board will interpret the shutdown code, and display a shutdown message on the display of the Control Center.

After the coastdown period has timed out, the chiller will automatically restart, if the shutdown is no longer active. Leave the Compressor Switch in the Run position. The chiller will start if no faults are active.

VSD - DC Bus Voltage Imbalance

Message: **BUS VOLTAGE IMBALANCE FAULT**

The DC link is filtered by many large, electrolytic capacitors, which are rated for 450 VDC. These capacitors are wired in series to achieve a 900 VDC capability for the DC link. It is important that the voltage is shared equally from the junction of the center, or series capacitor connection, to the negative bus and to the positive bus. This center point should be approximately $\frac{1}{2}$ of the total DC link voltage. If the voltage is greater than ± 88 VDC from the $\frac{1}{2}$ of the total DC link voltage, then this shutdown will occur.

First verify the operation of the DC bus voltage isolation board, and all associated wiring to the OSCD logic board. Many times the actual bus voltage imbalance conditions are caused by a shorted capacitor, or a leaky or shorted IGBT transistor in the power unit. In order to check for these conditions, connect a 12 VDC source (such as a battery charger used to charge automobile batteries) and apply 12 VDC between the positive bus and negative bus plates on the power unit while measuring the voltage from center to plus, and center to minus. The bank, which is causing the imbalance, will be evident via unequal voltage readings.

Possible Problems:

- Bleeder resistors failure due to overheating. Ensure that thermal grease is applied when the resistors are replaced.
- OSCD's built after 5/05 no longer use thermal grease on the bleeder resistors. They use a thermal pad and a 2.4 k ohm resistor.
- Ensure that both of the bleeder resistors are of the same value. If one 2.0 k ohm resistor were to fail, then both resistors should be replaced with the 2.4 k ohm resistor and a thermal pad.
- Failure of the bus voltage isolation board. Use 2 DC volt meters to verify the voltage across the 2 halves of the DC bus. If the voltage is correct, then measure the DC bus voltage at the J3 connector of the OSCD logic board.
- A shorted or open capacitor in one half of the bank.

VSD - High DC Bus Voltage

Message: **BUS OVER-VOLTAGE FAULT**

The DC bus voltage is continuously monitored by the OSCD logic board through the bus voltage isolation board. If the level exceeds 745 VDC (for 400 or 460 VAC line voltage) and 909 VDC (for 575 VAC line voltage), a shutdown is initiated. This shutdown will protect the capacitors from a voltage that exceeds this rating.

Possible Problems:

- Ensure that the line voltage is within the specification for your application. For example, the line voltage specification for a 460 VAC drive is 414 to 508 VAC or a 10% variation.
- Ensure that this shutdown is not a result of a storm. Verify that the compressor motor is not shorted.

VSD - High Internal Ambient Temperature

Message: **HIGH AMBIENT TEMPERATURE FLT**

The ambient temperature of the OSCD is monitored by a temperature sensor mounted on the OSCD logic board. The high ambient trip threshold is set for 145°F (63°C) for all Hp's except the 424 Hp which has a trip threshold of 153°F (67°C). If this fault occurs, the fans and coolant pump will remain turn on until the internal ambient temperature has fallen to 137°F (58°C) for all Hp's except the 424 Hp will continue to run the fans and pumps until the internal ambient temperature has fallen to 145°F (63°C).

Possible Problems:

- Improper coolant level for the drive.
- Internal fan failure at the cooling coil.
- Entering condenser water temperature of greater than 114°F or 45°C.
- Dirty shell and tube heat exchanger. Regular maintenance of tube cleaning once a year is required.
- Low Condenser Flow - The OSCD system requires 8 feet of head on the condenser to maintain adequate GPM. If the head is less than 8 feet, it will be necessary to correct the flow problem, or add a booster pump as is sometimes applied on remote mounted retrofit OSCDs.
- Failure of the fan or pump relay.

VSD - High Phase A (or B, C) Instantaneous Current

Message: **PHASE A (OR B, C) OVERCURRENT FAULT**

This shutdown is generated by the OSCD logic board. If any one phase of motor current as measured by the Output Current Transformers exceeds a threshold as determined by the OSCD logic board a shutdown will occur. Refer to the chart below for the shutdown threshold value.

DRIVE HP RATING	THRESHOLD SHUTDOWN VALUE
270, 292, 351, 424	771 amps peak
385, 419, 503, 608	1200 amps peak
608(400VAC), 658, 704	1890 amps peak
900	2749 amps peak

If an Instantaneous Current Fault occurs, but the chiller restarts and runs without a problem, the cause may be attributed to a voltage sag on the utility power feeding the OSCD that is in excess of the specified dip voltage rating for this product. This is especially true if the chiller was running at, or near, full load. If there is a sudden dip in line voltage, the current to the motor will increase, since the motor wants to draw constant horsepower. The change in the output current due to an input power fluctuation is a very quick event on the order of several line cycles. The chiller vanes cannot close quickly enough to correct for this sudden increase in current, and the chiller will trip on this fault.

Possible Problems:

- Normal condition if a large power consuming device is started, such as another chiller, or large machinery. If this is the case then the chiller will auto restart.
- OSCD logic board failure. Rotate the J8, J9, and J10 connectors on the OSCD logic board. If the fault continues on the same output phase, then the OSCD logic board has failed. If the fault follows the output phase then continue. Be sure to return the connectors to their correct location after this test. If the connectors are not returned, then the KW reading will not be correct.
- Shorted OSCD power unit. Perform troubleshooting check for Failure of the OSCD Power Module.
- Power supply failure on the IGBT gate driver board will be indicated by one of the six LED not being lit.
- Shorted motor, Meg the motor phase to phase and phase to ground.
- The motor or compressor has a locked rotor. Ensure that the coupling between the motor and compressor is free to rotate.
- Power factor correction capacitors are applied on the same input line as the drive.
- Too much refrigerant in the chiller causing carry over.
- Refrigerant level sensor or system not working properly.

VSD - Initialization Failed

Message: **VSD INITIALIZATION FAILED**

At power-up, the OSCD logic board will go through a process called initialization. At this time, memory locations are cleared, jumper positions are checked, and serial communications links are established between the OSCD logic board, ACC board, and the Control Center.

Possible Problems:

- The Control Center and the OSCD must be energized at the same time. The practice of pulling the fuse in the control center to make wiring changes will create a problem. Power-up must be done by closing the main disconnect on the OSCD cabinet with all fuses in place. Be sure you do not have an open fuse, causing loss of power to the OSCD logic board.
- The EPROMs must be correct for each board, and they must be correctly installed. There are a total of seven (7) EPROMs in each OSCD - Micropanel system. These EPROMs are created as a set, and cannot be intermixed between earlier and later styles of units. Also, the ACC EPROM must be in the ACC board, and the Micropanel EPROM in the Microboard, etc. All pins must be properly inserted into the EPROM sockets. Refer to the Software Reference List.
- Serial data communications must be established. See the write-ups for the messages, “Serial Receive Fault”. If communication among the OSCD logic, the filter logic, the ACC board and the Microboard does not take place at initialization, the “VSD Initialization Failed” message will occur before any other message can be generated. You can check to see that serial communications has been established by selecting the Motor Screen and verifying the drive horsepower. A zero displayed value for this parameter (and all other OSCD parameters) indicates a serial communications link or EPROM problem.
- If the Harmonic Filter option is included, make sure the Harmonic Filter Logic board is not in continuous reset. This will be evidenced by the LEDs on the filter logic board alternately blinking. This situation is addressed elsewhere in this literature. To rule out the Harmonic Filter as the cause of initialization failure, you can disconnect the filter by switching the filter logic board’s SW1

switch to the OFF position, and removing the 16 wire ribbon cable between the Harmonic Filter logic and OSCD logic boards.

- Many times when the OSCD logic board is replaced the small U40 chip is not transferred to the new board. Ensure that the U40 chip is properly installed.

VSD - Invalid Current Scale Selection

Message: **INVALID CURRENT SCALE FAULT**

This shutdown is generated by the OSCD logic board. The J1 connector on the OSCD logic board contains jumpers along with wires from the output CTs. Since the part number of the logic board is the same on all horsepower sizes, the jumpers tell the logic board the size of the OSCD being employed in order to properly scale the output current. If the jumper configuration is found by the logic board to be invalid, the system will be shut down and the above message will be generated.

Possible Problems:

- The wire jumpers on the J1 connector or pins in the J1 connector of the OSCD logic board may not be properly installed, loose, or missing. Refer to the chart below for the proper jumper configuration.

DRIVE HP RATING	WIRE JUMPER CONFIGURATION
270, 292, 351, 424	J1-9 to J1-10
385, 419, 503, 608	J1-9 to J1-11
685, 704	J1-9 to J1-12
900	No Jumper installed in J1-9, J1-11, or J1-12

If the wire jumper is not connected then the OSCD will tell the control center that an 1100 Hp drive is connected. The current displayed on the control center will be correct.

VSD - Logic Board Power Supply

Message: **MAIN BOARD POWER SUPPLY**

This shutdown is generated by the OSCD logic board, and it indicates that one of the low voltage power supplies for the OSCD logic board has dropped below their allowable operating limits. The power supplies for the logic boards are derived from the secondary of the 120 to 24 VAC transformer (*Figure 4 on page 18*) which in turn is derived from the 480 to 120 VAC control transformer (*Figure 4 on page 18*).

Possible Problems:

- This message normally appears when the power is removed and reapplied. This is not a failure, but the rest of the steps should be followed if this shutdown persists.
- The small control transformer that provides power to the OSCD is failing. Measure the output of the transformer with a DVM. The voltage should be between 24 – 32 VAC.
- The input voltage to the small control transformer is too low. Measure the input voltage of the transformer with a DVM. The voltage should be between 108 – 132 VAC.
- A power supply on the OSCD logic board may have failed. Measure the DC voltage test points on the OSCD logic board at TPC (+15V), TPD (+10V), TPE (+5V), TPF (+7.5V) and TPG (-15V) with respect to TPH (Ground). These power supplies have a tolerance of +/- 5%. If the measured voltage is not within the 5% tolerance then the power supply has failed, and the OSCD logic board should be replaced.

VSD - Logic Board Processor

Message: PWM COMMUNICATIONS FAULT

This shutdown is generated by the OSCD logic board. If a communications problem occurs between the two microprocessors on the OSCD logic board, then is shutdown will occur.

Possible Problems:

- If this shutdown should occur, replace the OSCD logic board.

VSD - Low Converter Heatsink Temperature

Message: LOW CONV HEATSINK TEMP.

This shutdown is generated by the OSCD logic board. A thermistor sensor is located on the SCR/Diode block side of the copper chill plate on the OSCD Power Unit. If at anytime this thermistor detects a temperature of 37°F (3°C) or lower a shutdown will occur.

Possible Problems:

- In most cases, the problem will actually be an open thermistor or broken wiring to the thermistor. Remove the J2 connector from the OSCD logic board. With a DVM measure the resistance of the thermistor.

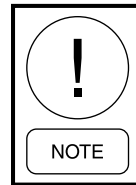

DO NOT insert the probes of the meter into the J2 connector where it makes a connection with the OSCD logic board. This will cause the sockets in the J2 connector to spread apart and cause an intermittent connection. Instead insert the probes into the back of the J2 connector.

Refer to Table 3 below for thermistor resistance verses temperature values.

TABLE 3 - OSCD - THERMISTOR CHARACTERISTICS

TEMP°F NOMINAL	TEMP°C NOMINAL	R-THERMISTOR IN OHMS FOR CONVERTER*	R-THERMISTOR IN OHMS FOR BASEPLATE
70	21	11900	4900
80	27	9300	4230
90	32	5600	3750
100	38	4600	3150
110	43	4660	2730
120	49	3760	2350
130	54	3050	1980
140	60	2490	1600
150	66	2040	1400
160	71	1690	1200
170	77	1400	950
180	82	1170	800
190	89	981	700
200	93	50	625

- Also, make certain one side of the circuit is not shorted to the cabinet. Sometimes a thermistor wire can be pinched against the enclosure.
- The thermistor has short cable. The short cable is connector to a longer cable that provided information back to the OSCD logic board. Ensure that this connector is properly connected.

VSD - Low DC Bus Voltage

Message: **LOW DC BUS VOLTAGE FLT**

The OSCD logic board determines this shutdown with information from the bus isolator board. If the line voltage were to quickly drop the current seen by the motor could exceed its rating. The low bus voltage shutdown will prevent this from happening. The shutdown is generated when the DC link voltage drops below 500 VDC for 460 VAC input voltage, 414 VDC for 400 VAC input voltage, or 600 VDC for 575 VAC input voltage when the drive is running.

Possible Problems:

- A common cause for this shutdown is a severe sag in the AC line to the drive. Monitor the incoming three phase AC line for severe sags, and also monitor the DC link voltage with a digital meter.
- There could be a wiring problem between the DC link, bus isolator board, or the OSCD logic board. Refer to the wire diagram for the wire numbers. Measure the voltage at J3 on the OSCD logic board.
- The input voltage to the SCR trigger board must be properly phased with the SCR gate wiring. If the wiring is not correct, then misfiring of the SCR will result and may cause the circuit breaker to trip.
- Verify that the SCR/Diode assembly is not open.



Care must be taken when making this measurement. The value should be around 600 VDC when the drive is running.

VSD - Low Inverter Baseplate Temperature

Message: **LOW INVERTER BASEPLATE TEMPERATURE FLT.**

This shutdown is generated by the OSCD logic board. A thermistor sensor is located inside the IGBT Module, or Modules on the OSCD power unit. Temperature information is sent from the thermistor to the IGBT gate driver board, and then to the OSCD logic board at the J2 connector. If at anytime this thermistor detects a temperature of 37°F (3°C) or lower a shutdown will occur.

Possible Problems:

- Refer to problems listed for the VSD – Low Converter Heatsink Temperature shutdown. Table 3 includes the resistance temperature information for thermistor in the IGBT module.
- The IGBT module must be replaced if the thermistor has failed.

VSD - Phase A (B, C) Gate Driver

Message: **PHASE A (B,C) GATE DRIVER FLT**

A second level of overcurrent current protection exists on the OSCD gate driver board. The collector-to-emitter voltage of each IGBT is checked while the device is turned on. This is also called the collector-to-emitter saturation voltage. If the voltage across the IGBT is greater than a set threshold as defined on the gate driver board, the IGBT is turned off and a shutdown pulse is sent to the OSCD logic board shutting down the entire OSCD system. This fault can also be caused if an IGBT is not being turned on when it should.

Possible Problems:

- A power supply problem on the gate driver board. Verify that the 6 LED's on the gate driver board are lit on the 270/292/351/424 Hp OSCD. Verify that the 2 LED's on each gate driver board are lit on the 385/419/503/608/658/704/900 Hp OSCD. The gate drive board is located on top of the IGBT module. If any one of the LED's are not lit, then the bad gate driver board has failed and requires replacement of the OSCD power module.

- The power supplies for the gate driver boards are generated on the SCR trigger board. Verify the wiring between the SCR trigger board and the IGBT gate driver boards. To ensure that power supplies are good measure the voltage from TPF and TPG to ground. The voltage should be around 12.5 VDC. Also ensure that the voltage on J7 between pins 5 and 6, and pins 7 and 8 is 5 VDC.
- A failure may have occurred in the OSCD logic board. If the problem repeatedly occurs in one phase, swap all three gate driver board cables at the OSCD logic board J8, J9, and J10. Plug J8 into J9, J9 into J10, and J10 into J8. If the display now reports a trip in a different phase, the problem is not in the OSCD logic board. The cables must be returned to their proper location for proper KW reading to occur.
- The fault could also be caused by a problem in the drive line. Ensure that the compressor is free to rotate. Also ensure that the motor is not grounded phase to ground or phase to phase.
- Too much refrigerant in the chiller causing carry over.
- Refrigerant level sensor or system not working properly.

VSD - Precharge - DC Bus Voltage Imbalance

Message: PRECHARGE BUS V IMBALANCE

The definition for this fault is identical to “VSD - DC Bus Voltage Imbalance”, except that the fault has occurred during the precharge period, which begins during pre-lube. Refer to “VSD - DC Bus Voltage Imbalance” shutdown for possible problems.

VSD - Precharge - Low DC Bus Voltage

Message: PRECHARGE LOW VOLTAGE FAULT

The OSCD logic board determines this shutdown with information from the bus isolator board. This fault has two different timing events. First, the DC Bus voltage must be equal to or greater than 50 VDC for 460 VAC input voltage, 41 VDC for 380-415 VAC input voltage, and 60 VDC for 575 VAC input voltage 4 seconds after precharge has begun. Second, the DC Bus voltage must be equal to or greater than 500 VDC for 460 VAC input voltage, 414 VDC for 380-415 VAC input voltage, and 600 VDC for 575 VAC input voltage 20 seconds after pre-charge has begun. This shutdown is important to determine if the converter or the cap. bank is shorted.

Possible Problems:

- Shorted cap. bank. Place a DC volt meter across the laminated bus structure. Measure the voltage. If voltage is present, then the caps. are not shorted. If voltage is not present, then take an ohm meter and verify if the cap. bank is shorted or not.
- The OSCD logic board is not getting bus voltage information. Place a DC volt meter at J3 on the OSCD logic board pins 1 and 3. Start the drive. If the voltage does not come up, then verify the wiring between the bus voltage isolation board, OSCD logic board, and the laminated bus structure.
- The converter is not being told to turn on. Verify that J4 on the SCR trigger board is properly installed. Verify that J6 on the OSCD logic board is properly installed. Measure the DC voltage at J4 on the SCR trigger board pin 3 to ground. The voltage should go to 0 VDC when the drive enters precharge. If this does not happen, then verify the wiring between the SCR trigger board and the OSCD logic board.
- The converter is not turning on. Verify the wiring between the SCR trigger board and the SCR gates. Also verify the wiring between L1-L3 on the SCR trigger board and L1-L3 to the input of the drive at the circuit breaker and up to the SCR anode connection.
- Measure the DC voltage at J1-J3 on the SCR trigger board. The voltage should be 1-3 VDC when the drive enters precharge. If the voltage is around 15 VDC, then the SCR trigger board has failed or the SCR gate is open. If the voltage is 0 VDC, the SCR trigger board had failed or the SCR gate is shorted.

VSD - Run Signal

Message: RUN RELAY FAULT

Two run signals are generated by the Control Center, one via wire #24 and the second via the serial communications. Upon receipt of either of the two run signals by the OSCD logic board, a 5-second timer will begin on the OSCD logic board. If the missing run signal is not received within the 5-second window the OSCD logic board will shut down, and the Control Center will display the shutdown message.

Possible Problems:

- This shutdown could occur if there is a problem with the wiring between the Control Center and the OSCD logic board. Check the #24 to #25 horseshoe jumper in the Control Center, and all other wiring involved in energizing #24 in the OSCD.
- Verify that the serial communications wiring between the micro board, the ACC board, and OSCD logic board are connected properly.
- Verify the control center microboard communications is working properly. Refer to reference material for more information.

VSD - Serial Communications**Message: SERIAL RECEIVE FAULT**

The OSCD logic board generates this message. When the communications between the micro board and the ACC board, or the ACC board and OSCD logic board is disrupted for a least 22 seconds.

Possible Problems:

- Ensure that the chiller system is properly grounded for electrical noise. The OSCD is the source of ground for the chiller. Ground is then conducted to the rest of the chiller by the mounting connections of the drive, compressor motor, and the Control Center. All connections are to be made with external tooth lock washers. These washers will cut through the paint on the chiller and provide a ground connection. The grounding system is critical for proper communications.
- Check the shielded cable between J11 on the OSCD logic board and J8 on the ACC board. Check for continuity and also check to see that none of the conductors are shorted together or shorted to ground. The terminal block in the lower left corner of the OSCD cabinet serves as a junction point for this cable, and it is possible for strands of wire to bridge across the terminals at this location.
- Verify that the shielded cable is properly grounded. Ensure that the chiller and the Control Center are properly ground through the OSCD. The shield should not be connected to chassis ground

at the mounting plate for the conduit. The shield should only have one connection the Control Center enclosure. Remove the shield from the ground and verify that no other ground connections exist with an ohm meter. The shield should not go to ground through the ACC board. This has been a common problem on field retrofits. (If the optional harmonic filter is installed, then repeat this and the above step for the cable connected between the J9 connector on the ACC board and J8 connector on the filter logic board.)

- Ensure that the ACC board is properly grounded. In some cases, the ACC board is grounded through a very long wire. Changes were made to directly ground the ACC board to the Control Center enclosure. J6 pin 1 is the ground connection for the ACC board. This pin should be connected to the Control Center enclosure right next to the ACC board.
- Ensure that newer software is installed in the ACC board. Communications were improved with software version C.ACC.01.03a and later.
- Improper connection of the J9 connector on the ACC board. The J9 connector on the ACC board is for the communications from the harmonic filter logic board. If the harmonic filter is not installed, then the cable connected to J9 can be a source of electrical noise. The J9 connected should be removed from the ACC board if the optional harmonic filter is not installed.
- If the harmonic filter is installed, then the fault can be generated when the communications between the OSCD logic board and the harmonic filter logic board, or the harmonic filter logic board and the ACC board is disrupted. If possible disconnect the harmonic filter logic board to determine if it is at fault. If the communications work properly with the harmonic filter logic board disconnected, then verify the software version. If the software version is correct, then replace the board.
- If all of this has been done and communications can never be established, even at power-up, you may have a bad communications driver on either the OSCD logic or the ACC boards. Change out both the ACC and OSCD logic boards.

VSD - Single Phase Input Power

Message: **SINGLE PHASE POWER SUPPLY**

This shutdown is generated by the SCR Trigger board and relayed to the OSCD logic board to initiate a system shutdown. The single phase control uses circuitry to detect if any one phase has dropped below 230 VAC for a 460 VAC 60 Hz or 400 VAC 50 Hz line, or 300 VAC on a 575 VAC 60 Hz line. The trigger board will detect the loss of a phase within one half line cycle of the phase loss. An LED on the SCR Trigger board will indicate that the board is detecting the fault, and not a wiring problem between the SCR trigger board and the OSCD logic board.

Possible Problems:

- This message is typically displayed every time power to the OSCD is restored or if the input power dips to a very low level. This is not an indication of a problem with the OSCD.
- Verify the input fuses to the SCR trigger board are not open. The fuses that supply power to the SCR trigger board also supply power to the oil pump motor and the oil heater. A failed fuse may indicate a failure in one of these other components.
- Verify continuity between the J4 connector on the SCR trigger board and the J6 connector on the OSCD logic board. A failure in the wiring can cause this shutdown.

VSD - Stop Contacts Open

Message: **INVERTER INITIATED STOP FAULT**

Whenever the OSCD initiates a fault, it first opens the K1 relay on the OSCD logic board. When the relay opens the voltage between wire #53 and #16 will be 115 VAC. It then sends a message through the serial port to the ACC board, detailing the cause of the fault. If wire #53 to #16 circuit ever opens without receiving an accompanying cause for the trip over the serial link (within 11 communication tries, approximately 22 seconds) this message will be displayed. This message will also be displayed if the verification jumper on J1 pins 7 and 8 are loose or not connected to the OSCD logic board. This fault maybe replaced with a Serial Communications fault if the serial link has failed.

Possible Problems:

- Ensure that all wiring from wire #1 to #53 horse-shoe jumper in the Control Center and all other wiring involving #53 and #16 are properly connected.

- Ensure that 115 VAC is available to wire #53 at the J1 connector.
- Verify that the J1 connector on the OSCD logic board is properly installed. Also ensure that the J1 pin 7 and 8 jumper is installed and the pins are properly seated.
- Ensure that the control panel input/output board is working properly.

Harmonic Filter - 110 % Input Current Overload

Message: **FLTR OVERLOAD FLT**

This shutdown is generated by the harmonic filter logic board. The three phases of filter current are measured by the output DCCTs, and information is sent to the harmonic filter logic board. If any one phase of filter current exceeds a threshold for 40 seconds a shutdown will occur. Refer to the following table for the shutdown threshold value.

DRIVE HP RATING	THRESHOLD SHUTDOWN VALUE
270/292/351/424	128 amps RMS
388/419/503/608	176 amps RMS

Possible Problems:

- Verify that the values of Total Harmonic Distortion (THD) are low and balanced. Turn off the OSCD and monitor the THD for each phase. The value should be around 5%. If the value of THD is much higher or if it is not balanced, then the harmonic content of the line is too high and the harmonic filter is responding to it.
- Ensure that the values of Total Demand Distortion (TDD) are balanced. If the currents are not balanced, then there may be a problem in the harmonic filter power unit or the harmonic filter logic board. Verify the wiring between the harmonic filter logic board and the harmonic filter power unit.

Harmonic Filter - DC Bus Voltage Imbalance

Message: **FLTR BUS V IMBALANCE FLT**

The DC bus voltage isolation board provides a high resistance between the harmonic filter DC link and the harmonic filter logic board. This resistance limits the current flowing between the bus capacitors and the Harmonic filter logic board. The harmonic filter logic board then determines if this fault has occurred.

The filter DC link is filtered by large, electrolytic capacitors, which are rated for 450 VDC. These capacitors are wired in series to achieve a 900 VDC capability for the DC link. The 424 and 608 Hp drives use higher voltage rated capacitors, but 2 in series are still required. It is important that the voltage be shared equally across each capacitor, or the capacitor rating may be exceeded and possibly fail. The DC isolation board is connected to the plus bus, minus bus, and where the 2 series capacitors are connected to each other. The harmonic filter logic board then measures the voltage between the plus bus and the series connection, and the minus bus and the series connection of the bus capacitors. If at anytime while the harmonic filter is running these 2 measurements become unequal by 50 VDC (for 460 and 400 VAC input voltage) 65 VDC (for 575 VAC input voltage), then a shutdown will occur.

Possible Problems:

- Bleeder resistors failure due to overheating. Ensure that thermal grease is properly applied when the resistors are replaced. With power removed from the drive and the DC link voltage discharged below 10 VDC, disconnect the harmonic filter bleeder resistors. Measure the ohm value of the bleeder resistors. The ohm value should be 3000 ohms within 5%. Drives built after 5/05 no longer use thermal grease, but use a thermal pad. Ensure that the resistors are properly tightened to the assembly. No torque specification is required.
- Verify all wiring between the DC link and the harmonic filter logic board. Also check for loose connections.
- Failure of the bus voltage isolation board. With power removed from the drive and the DC link voltage discharged below 10 VDC, disconnect the bus voltage isolation board from the circuit. Using an ohm meter measure from J1-1 to J2-1. The ohm value should be 150 K ohms. Repeat this test for the remaining 2 connections. If any one of the reading is not 150 K ohms to within 1%, then the board needs to be replaced.
- Shorted capacitor in one half of the DC link. Place one DC volt meter from the plus bus to the series connection of the capacitors, the other from the series connection of the capacitors to the minus bus. Start the drive. When the drive starts to rotate the motor the harmonic filter will start to precharge. The precharge of the harmonic filter takes 5 seconds. During this time, the voltage should

remain equal to within the specification above. If a capacitor is shorted, then one of the volt meters will have a low voltage reading. This is the side of the DC link that has failed. Remove power from the drive, and ensure that the DC link voltage is below 10 VDC. Remove the laminated bus structure from the harmonic filter power unit. With an ohm meter measure the resistance of the DC link capacitors. A low reading would indicate a failed capacitor. Replace the cap. When replacing the capacitor ensure that the top of the capacitor is at the same height as the other capacitors in the DC link.

- An open capacitor can cause this problem as well. Using an analog meter on Rx10. Connect the meter to one side of the capacitor bank. The meter should first read a short and then the resistance should increase. The same test with the same results should be repeated for both side of the capacitor bank in both polarities. If the needle of the meter shows a resistance without first showing a short, then repeat the test. If the reading does not change then the capacitor is open and should be replaced.
- Failure of the harmonic filter logic board. Measure the voltage of the DC link at the harmonic filter logic board. This measurement is taken at J5 pins 5 and 6, J5 pins 6 and 7. During the precharge of the harmonic filter these 2 measurements should remain equal to within the specification above. If the measurements are correct, then the harmonic filter logic board has failed.

Harmonic Filter - DC Current Transformer 1(or 2)

Message: **FILTER DCCT 1 (OR 2) ERROR**

During initialization, with no current flowing through the Direct Current Current Transducers (DCCT's), the DCCT's output voltages are measured and compared with a preset limit in the harmonic filter logic board. If the measured values exceed the preset limits, the DCCT's are presumed to be bad and this shutdown will be generated.

Possible Problems:

- Verify the wiring between the DCCT's and the harmonic filter logic board.

- Power supply failure to the DCCT. Check for the presence of the +15 VDC power supplies by measuring the voltages at filter logic board J3 pins 6 and 10 with respect to signal ground (J3 pin 2). Check for the presence of the -15 VDC power supplies by measuring the voltages at filter logic board J3 pins 7 and 11 with respect to signal ground (J3 pin 2). If the power supply is not correct, then replace the harmonic filter logic board.
- The output voltage from the DCCT is not correct. While the OSCD is powered but not running, measure the DC voltage from J3 pin 5 and J3 pin 12 with respect to signal ground (J3 pin 2) on the harmonic filter logic board. Neither voltage should be greater than +/- 0.147 VDC. If the above step is correct, and this step fails, then replace the failed DCCT.

Harmonic Filter - High DC Bus Voltage

Message: **FLTR BUS OVER-VOLTAGE FLT**

The harmonic filter logic board continuously monitors the harmonic filter DC link voltage if the level of the DC link voltage exceeds a range of 822 to 900 VDC (for 460 and 400 VAC input voltage) 999 to 1099 VDC (for 575 VAC input voltage), this shutdown is initiated. Keep in mind that the harmonic filter has its own DC bus as part of the harmonic filter power unit. The harmonic filter DC Link is not connected in any way with the drive's DC Link.

Possible Problems:

- Verify that the line voltage is not greater than the specified input voltage range for this model of drive.
- Voltage surge on the input line voltage. Ensure that power quality has not changed during the shutdown. This could include storms, line switching, or rapid changes in line loading.

Harmonic Filter - High Phase A (B, C) Current

Message: **FLTR PHASE A (B,C) OVERCURRENT**

The output current of the harmonic filter is read by the Direct Current-Current Transducer (DCCT). This current information is sent to the harmonic filter logic board where it is compared against a threshold. If the output current of the harmonic filter power unit is greater than the threshold, then the harmonic filter will

turn off for 5-6 line cycles. After that time the filter operation will resume. If the harmonic filter operation is stopped 3 times within a period of 60 line cycles, then the filter and OSCD power units are shut down and this message is generated.

DRIVE HP RATING	THRESHOLD SHUTDOWN VALUE
270/292/351/424	378 ±59 amps Pk
385/419/503/608	523 ±84 Amps Pk

Possible Problems:

- Line voltage transients. If the OSCD shutdown and auto-restarts without any additional problems, then the problem is likely due to a sag or surge in the line voltage.
- Filter power unit failure. In some cases, the IGBT in the harmonic filter power unit has failed. Refer to troubleshooting procedure for failure of the Harmonic Filter Module to determine this failure.

Harmonic Filter - Logic Board Or Communications

Message: **IEEE-519 FILTER FAULT**

This shutdown states that the hardware on the harmonic filter logic board is indicating a fault, but the software on the harmonic filter logic board does not state why. The filter logic board signals a fault condition by opening a transistor. The OSCD logic board detects the open transistor at the J7 connector pin 9. In turn, the OSCD logic board then opens its fault relay to indicate a fault to the Control Center. When fault data is requested of the harmonic filter logic board it does not respond with fault information.

Possible Problems:

- Verify the 16-pin ribbon cable for continuity between the OSCD logic and Harmonic Filter logic boards. Focus on this test around pin 9 of the cable.
- Ensure that the communication system is working between the Harmonic Filter logic board, the Adaptive Capacity Control board, and the OSCD logic board.

Harmonic Filter - Logic Board Power Supply

Message: **FLTR POWER SUPPLY FLT**

This shutdown indicates that one of the low voltage power supplies on the harmonic filter logic board have dropped below their permissible operating voltage range. The filter logic board receives its power from the OSCD logic board via the ribbon cable, which connects the two. The power supplies for the OSCD logic boards are in turn derived from the secondary of the 120 to 24 VAC transformer (*Figure 6 on page 22*), which in turn is derived from the AC line input to 120 VAC control transformer (*Figure 4 on page 18*).

Possible Problems:

- Verify that CR10 LED is lit on the harmonic filter logic board. This LED indicates that the power supplies on the board are ok. If the CR10 LED is lit, then likely the harmonic filter logic board has failed, and it needs to be replaced.
- If CR10 LED is not lit, then verify the ribbon cable for continuity between the OSCD logic and Harmonic Filter logic boards.
- Verify the power supply voltages on the harmonic filter board. With a voltage meter verify the following voltages.

J7 pin 3-7 is +15 VDC

J7 pin 4-7 is +5 VDAC

J7 pin 5-7 is -5 VDC

J7 pin 6-7 is -15 VDC

Harmonic Filter - Low DC Bus Voltage

Message: **FLTR LOW BUS VOLTAGE FLT**

The harmonic filter dynamically generates its own filter DC link voltage by the interaction of the harmonic filter choke and switching its IGBT's. This DC level is actually higher than the level obtained by simply rectifying the input line voltage. **Note: The DC link voltage is always higher on the harmonic filter power unit than on the OSCD VSD power unit.** Thus the harmonic filter actually performs a voltage “boost” function. This is necessary in order to permit current to flow into the AC line from the harmonic filter when the AC line is at its peak level. This particular shutdown and its accompanying message are generated when the harmonic filter's DC link voltage drops to a level less than 80 VDC (for 460 and 400 VAC input voltage) 100

VDC (for 575 VAC input voltage), below the harmonic filter DC link voltage setpoint. The harmonic filter DC link voltage setpoint is determined by the harmonic filter logic board by measuring the three phase input line-to-line voltage. The harmonic filter logic board measures the input line voltage through the AC line isolator board. This setpoint is set to the peak of the sensed input line to line voltage plus 59 volts (for 460 and 400 VAC input voltage) 118 VDC (for the 608 Hp drive) and 88 volts (for the 424 Hp drive), but not to exceed 760 volts (for 460 and 400 VAC input voltage) 993 VDC (for 575 VAC input voltage). The setpoint will vary with changes in the input line to line voltage.

Possible Problems:

- If this shutdown occurs occasionally, the likely cause is a severe sag in the input line voltage. A power monitor should be installed to determine if a power problem exists.
- Verify the operation of the AC line voltage isolator board. Measure the output of the line voltage isolation board at connector J5, pins 1, 2, and 3 on the harmonic filter logic board. With 480 VAC present on the input to the line voltage isolation board, approximately 5.2 VAC should be present from pins 1 to 2, pins 2 to 3, and pins 3 to 1. The voltages should be balanced as opposed to the voltage being exactly 5.2 VAC.

Harmonic Filter - Phase Locked Loop

Message: **FLTR PHASE LOCK LOOP FLT**

This shutdown indicates that a circuit called a “phase locked loop” on the harmonic filter logic board has lost synchronization with the incoming power line for a period of time.

Possible Problems:

- This is normally an indication that one of the harmonic filter's input power fuse is open. Check the operation of the harmonic filter power fuses 8FU, 9FU and 10FU.
- If the fuses are OK, then measure the output of the line voltage isolation board at connector J5, pins 1, 2, and 3 on the harmonic filter logic board. With 480 VAC present on the input to the line voltage isolation board, approximately 5.2 VAC should be present from pins 1 to 2, pins 2 to 3, and pins 3 to 1. The voltages should be balanced as opposed to the voltage being exactly 5.2 VAC.

Harmonic Filter - Precharge - Low DC Bus Voltage

Message: **FLTR PCHARGE LOW BUS V FLT**

This shutdown requires that two minimum voltage thresholds must be exceeded in order to complete pre-charge. The first minimum voltage value occurs with in 1/10 of a second. The second minimum voltage value occurs near the end of the precharge at 5 seconds after the filter precharge relay is energized. View chart below for specific values. The unit is shut down, and this message is generated if these conditions are not met.

NOMINAL INPUT VOLTAGE VALUE	FIRST MINIMUM VOLTAGE VALUE	SECOND MINIMUM VOLTAGE VALUE
400-460 VAC	41 VDC	425 VDC
575 VAC	60 VDC	630 VDC

Possible Problems:

- Verify that the harmonic filter pre-charge relay is energized during pre-charge. If it is not, then verify wiring between the pre-charge relay and J4 pins 1 and 2 on the harmonic filter logic board.
- Verify that the harmonic filter pre-charge resistors are the correct ohm value, and are not damaged.

DRIVE HP RATING	PRE-CHARGE RESISTOR VALUE
270/292/351/424	10 ohms
385/419/503/608/658/704	16 ohms

- Measure the harmonic filter bus voltage during pre-charge to ensure that the bus is charging to the correct value or not. If bus is charging properly, then measure the bus voltage at J5 pin 5 to 7. The value at J5 should be nearly the same as the bus voltage measured on the bus. If the measurement is not the same, then measure the 3 resistors on the DC bus isolator board. Disconnect the DC bus isolator board and measure resistance at the terminals of the board. The measurement should be 150K ohms +/- 1%. If this measurement is not correct, then replace the DC bus isolator board. If the measurement is correct, then replace the harmonic filter logic board.

Harmonic Filter - Run Signal

Message: **FLTR RUN RELAY FLT**

When a digital run command is received at the harmonic filter logic board from the OSCD logic board via the 16 position ribbon cable, a 1/10 second timer is begun. A redundant run command must also occur on the serial data link from the OSCD logic board via the ribbon cable before the timer expires or the OSCD will be shut down and this message will be displayed.

Possible Problems:

- Verify the 16-pin ribbon cable for continuity between the OSCD logic and Harmonic Filter logic boards. Focus on this test around pin 12 of the cable.
- If the problem persists, replace the OSCD logic board and if the problem remains, the filter logic board.

WARNING MESSAGES

General Information

A WARNING message will indicate that the operation of the OptiSpeed Compressor Drive or the Harmonic Filter is affected in some manner, but the OptiSpeed Compressor Drive is still functioning.

Warning - Vanes Uncalibrated - Fixed Speed

Message: **VANES UNCALIBRATED - FIXED SPEED**

This message is displayed when the Pre-Rotation Vanes are not calibrated or have failed to calibrate, and the OptiSpeed Compressor Drive is enabled. Under this condition the OSCD will run at a constant maximum frequency. This message will no longer appear after a successful calibration.

Possible Problems:

- Ensure that the vane pot. is adjusted for zero vane opening. With the vanes fully closed, the DC voltage measured at J4 on the Adaptive Capacity Control board pin 1 to 2 should be 0.3 to 0.7 VDC. If this value is not correct, then adjust the vane pot. coupling.
- Verify the communications between the Adaptive Capacity Control, OptiSpeed Compressor logic, chiller Control Logic, and the Harmonic Filter logic boards.

- Ensure that the harmonic filter logic board is not in a reset condition. This is where the fault LED is flashing on the harmonic filter logic board. Verify that the correct EPROM versions are installed, and that the EPROM's are installed in the proper orientation. Ensure that the (2) 8 pin chips are properly installed as well. Many times the 8 pin chips are missed during a board replacement.
- Verify that the correct line number harmonic filter logic board is installed. Different line number boards are used for different horsepower OSCD.

Warning - Harmonic Filter - Operation Inhibited

Message: **FILTER - OPERATION INHIBITED**

This message is displayed when the function of the Harmonic Filter is inhibited at the Control Center. This message is no longer displayed when the function of the Harmonic Filter is enabled at the Control Center. The function of the harmonic filter can only be inhibited or turned on when the chiller is stopped.

If the chiller and OSCD are using MODBUS communications, then ensure that the OSCD software version is C.VSD.27.03.00 for 575 VAC or , C.VSD.17.03.00 for 460 VAC/60 Hz, 380-400 VAC/50 Hz, or C.VSD.47.03.00 for 400 VAC/60 Hz, 415 VAC/50 Hz.

Warning - Harmonic Filter - Data Loss

Message: **FILTER DATA LOSS**

This message is displayed when the communications link between the OSCD logic, and the harmonic filter logic, or the ACC boards are interrupted for at least a period of 20 seconds. This message can also occur as a background message when the chiller is running. When this message is displayed all filter related values are replaced with X's. If communications is re-established, the message will disappear, and normal values will again be displayed.

Possible Problems:

- Verify the 16-pin ribbon cable for continuity between the OSCD logic and Harmonic Filter logic boards. Focus this test around pin 9 of the cable.
- The integrity of the shielded communications cable between the harmonic filter logic board and the ACC board should also be checked.
- Ensure that the OSCD and the Control Center are properly grounded.
- Possibly a board failure has occurred. Replace the harmonic filter logic board.

SECTION 7 - START-UP PREPARATIONS

Circuit Breaker Setup

The circuit breaker used on the OSCD has many settings for overload, short circuit, and ground fault protection. Generally, these settings are adjusted by the manufacturer, but these settings should be verified before starting the chiller. The breaker settings on the 292/351 Hp OSCD are a little different than the 419/503 Hp

OSCD. The 292/351 Hp OSCD have settings for Instantaneous Short Circuit Trip Time and Ground Fault Trip Time have an ON and OFF adjustment. Verify that these two adjustments are set to the ON position. With the introduction of the 424 and 608 Hp drives new circuit breakers are being used.

TABLE 4 - CIRCUIT BREAKER SETTINGS FOR VSD MODEL DRIVE

SETTINGS FOR THE 292/351 HP OSCD CIRCUIT BREAKER PART NUMBER 224-30987-000 (USED BEFORE 6/06) GLOBAL DESIGN		
NAME OF ADJUSTMENT	ABBREVIATION OF ADJUSTMENT	SETTING VALUE
Long Time Overload Protection Coarse Multiplier	"IO"	"1"
Long Time Overload Protection Fine Multiplier	"IR"	"1"
Short Time Overload Protection Multiplier	"ISD"	"1.5"
Instantaneous Short Circuit Protection Multiplier	"II"	"2"
Ground Fault Protection Multiplier	"IG"	"0.2"
Short Time Overload Trip Time	"TR"	"0.5"
Instantaneous Short Circuit Trip Time	"TSD"	"0.1" ON
Ground Fault Trip Time	"TG"	"0.1" ON
SETTINGS FOR THE 270/292/351/424 HP OSCD CIRCUIT BREAKER PART NUMBER 224-35428-000 (USED AFTER 6/06) GLOBAL AND ASIA DESIGN		
NAME OF ADJUSTMENT	ABBREVIATION OF ADJUSTMENT	SETTING VALUE
Long Time Pickup	"IR"	"E"
Long Time Delay	"TLD"	"2"
Short Time Delay	"ISD"	"2"
Ground Fault Pickup	"IG"	"0.2"
Ground Fault Delay	"TSD"	"J"
SETTINGS FOR THE 385/419/503/608 HP OSCD CIRCUIT BREAKER PART NUMBER 224-34025-000 GLOBAL DESIGN		
NAME OF ADJUSTMENT	SETTING VALUE	
Short Delay Pickup	"2"	
Short Delay Time	"inst"	
Ground Fault Pickup	"1"	
Ground Fault Time	"inst"	
SETTINGS FOR THE 658/704 HP OSCD CIRCUIT BREAKER PART NUMBER 224-36981-000 (ASIA DESIGN)		
NAME OF ADJUSTMENT	ABBREVIATION OF ADJUSTMENT	SETTING VALUE
Long Time Pickup	IR	0.8
Long Time Delay	TR	0.5
Short Time Pickup	ISD	1.5
Short Time Delay	TSD	0.1 ON
Instantaneous Pickup	II	2
Ground Fault Pickup	IG	A
Ground Fault Delay	TG	0.1 ON

NOTE: Global Design LVD model drive use the same circuit breakers as the VSD models and the settings remain the same.

TABLE 5 - CIRCUIT BREAKER SETTINGS FOR LVD MODEL DRIVE

SETTINGS FOR THE 292/419 HP OSCD CIRCUIT BREAKER PART NUMBER (ASIA DESIGN)		
NAME OF ADJUSTMENT	ABBREVIATION OF ADJUSTMENT	SETTING VALUE
Long Time Trip (292 HP)	IR	400
Long Time Trip (419 HP)	IR	630
Long Time Delay	TR	12
Short Time Pickup	ISD	2
Instantaneous Pickup	li	10
Ground Fault Pickup	lg	0.2
Ground Fault Delay	TG	0.1
SETTINGS FOR THE 658/704 HP OSCD CIRCUIT BREAKER PART NUMBER 024W33863-521 (ASIA DESIGN)		
NAME OF ADJUSTMENT	ABBREVIATION OF ADJUSTMENT	SETTING VALUE
Long Time Trip	I1	1
Long Time Delay	t1	3
Short Time Pickup	I2	1.2
Short Time Delay	t2	0.1
Instantaneous Pickup	I3	2
Ground Fault Pickup	I4	0.2
Ground Fault Delay	t4	0.1
Freq. & Neutral Adjustment	Freq.&InN	50Hz, OFF
SETTINGS FOR THE 900 HP OSCD CIRCUIT BREAKER PART NUMBER 024W33863-522 (ASIA DESIGN)		
NAME OF ADJUSTMENT	ABBREVIATION OF ADJUSTMENT	SETTING VALUE
Long Time Trip	I1	1
Long Time Delay	t1	3
Short Time Pickup	I2	1.2
Short Time Delay	t2	0.1
Instantaneous Pickup	I3	2
Ground Fault Pickup	I4	0.2
Ground Fault Delay	t4	0.1
Freq. & Neutral Adjustment	Freq.&InN	50Hz, OFF

NOTE: Global Design LVD model drive use the same circuit breakers as the VSD models and the settings remain the same.

OptiView Control Center

Make certain the correct EPROMs are all installed in the proper locations by referring to the EPROM Reference List in this form. The list at the end of this form contains the earliest versions in which the product is supported. Be sure the dimple in the end of the chip is oriented in the correct direction. Ensure that jumper JP37 is cut on the OptiView panel micro board 031-01730-XXX.

Verify the circuit breaker settings (refer to the first section in the start-up preparations). Apply power to the OSCD, and check the System Status Line on the Control Center. After a few seconds you should get the message, "System Ready to Start". If you do not, turn off power, wait five minutes for the voltage to discharge, verify voltage is no longer present, and then double check all wiring and connections.

At this point, start-up is as simple as one, two, three...

7. If initial power-up is successful, set the Full Load Amps (FLA) on the OSCD by selecting the VSD Details Screen. On this screen is displayed the "Full Load Amps (some value)". Adjust this value to the FLA stamped on the compressor motor name plate by turning the small multi-turn trimpot located in the left-center area of the OSCD logic board inside the OSCD enclosure. Clockwise rotation of the trimpot will increase the value of FLA. You will need to alternate between making an adjustment, and checking the value on the Control Center, until the displayed value is correct within one amp.
8. Next, drain the coolant from the OSCD. The OSCD is now shipped with a 50/50 mix of Propylene Glycol and York Corrosion Inhibitor. This type of coolant is being used to protect the cooling loop from damage due to freezing conditions during the shipping process. This coolant mixture does not have the thermodynamic properties required by the OSCD during a running condition. Thus, this 50/50 mixture must be drained and replaced with YORK Corrosion Inhibitor as currently used in the OSCD. **Propylene Glycol is the same material used to winterize recreational vehicles. Although, it is non-toxic, follow any applicable local codes when discarding the solution.**
9. Next, fill the coolant loop using York's Corrosion Inhibitor, part number 013-02987-000. Pour the solution into the top of the header pipe until the

level is within a ½ inch of the top. Then run the pump by unplugging connector P2 on the OSCD logic board. The level in the fill-pipe will drop quickly. Add more coolant so the level is maintained at ½ inch from the top of the pipe. Continue to run the pump for 15 minutes, adding more coolant as needed, then reinstall P2, make certain the level is ½ inch from the top, and install the pipe plug in the header pipe using teflon tape to assure coolant does not evaporate through the pipe threads. Do not wrap the threads with more than 2 wraps of Teflon tape. Too much tape can cause the fill pipe to crack. **Note the pipe plug has straight threads, and could fall into the reservoir.**

10. The BRAM on the ACC board should be cleared to ensure that the surge map is clean, and no data is stored that may keep the OSCD from slowing down. This procedure should not be performed on a regular basis, and will cause extra surging of the compressor.
 - Enter an Access Code of 1380
 - Select the Motor Screen
 - Select the ACC Details Screen
 - Press the Surge Map Clear key
 - A window will appear prompting for a code. Enter the value of 0368, and press the check key.
 - Open the OptiView Control Center door and press the small SW1 button on the ACC board. This must be performed within 20 seconds of pressing the check key. Also the small button must be pressed for 1-3 seconds.
 - A message will appear that the surge map has been cleared. To verify that the surge map is cleared check that the vane position no longer reads 0 and now displays X.
11. The vanes must now be calibrated. The vane pot itself was previously installed, and should have been set so that neither end of travel runs up against either end-stop of the pot. The closed end of the pot should be set for a feedback voltage somewhere between 0.3 and 0.7 VDC, as measured from the wiper (white wire) to common (black wire). The full-open feedback voltage must be greater than the closed value by 0.10 VDC. For example, you might get a range of 0.54 VDC closed, to 1.12 VDC at full open. This range of

voltage will be scaled by the Adaptive Capacity Control Board (ACC) to a range of 0% to 100% open. The ACC will store the voltage that corresponds with the percentage of vanes in its BRAM chip.

This scaling is accomplished by an automatic calibration routine in the OptiView Control Center. To perform the auto-calibration perform the following:

- Enter an Access Code of 1380
- Select the Compressor Screen
- Select the Pre Rotation Vane Calibrate Screen
- Press the Start Calibration key
- The Calibration in Progress and Pre Rotation Vane Opening LEDs' will light.
- The vanes will run to the full open position and stop.
- After a short period of time, the Pre Rotation Vane Closing LED will light.
- The vanes will run to the full closed position and stop.
- A message will appear on the screen, "PRV Calibration was Successful"
- If " PRV Calibration was Successful" is not displayed, then verify the operation of the vane arm, vane pot, the cable between the vane pot and the ACC board, and that the shield of the vane pot. is connected to the OptiView Control Panel enclosure.

If any difficulty is encountered with these procedures, refer to the other sections of this publication for solutions.

Micro Computer Control Center

Make certain the correct EPROMs are all installed in the proper locations by referring to the EPROM Reference List in this Form. Be sure the dimple at the end of the chip is oriented in the correct direction.

Verify the circuit breaker settings (refer to the first section in the start-up preparations). Apply power to the OSCD, and check the front panel display. After a few seconds you should get the message, "System Ready to Start". If you do not, turn off power, wait five minutes

for the voltage to discharge, verify voltage is no longer present, and then double check all wiring and connections.

At this point, start-up is as simple as one, two, three...

1. If initial power-up is successful, set the Full Load Amps (FLA) on the OSCD by pressing the "Options" key. You will see a display of "VSD 100% Job FLA = (some value) Amps". Adjust this value to the correct FLA as stamped on the motor name plate by turning the small multi-turn trimpot located in the left-center area of the OSCD logic board inside the OSCD enclosure. Clockwise rotation of the trimpot will increase the value of FLA. You will need to alternate between making an adjustment, and checking the value on the display, until the displayed value is correct within one amp.
2. Next drain the coolant from the OSCD. The OSCD is now shipped with a 50/50 mix of Propylene Glycol and York Corrosion Inhibitor. This type of coolant is being used to protect the cooling loop from damage due to freezing conditions during the shipping process. This coolant mixture does not have the thermodynamic properties required by the OSCD during a running condition. Thus, this 50/50 mixture must be drained and replaced with YORK coolant as currently used in the OSCD. Propylene Glycol is the same material used to winterize recreational vehicles. Although it is non-toxic we suggest permission should be obtained before discarding it into a sewer.
3. Next, fill the coolant loop using York's pre-mixed Corrosion Inhibitor solution, part number 013-02987-000. Pour the solution into the top of the header pipe until the level is within a ½ inch of the top. Then run the pump by unplugging connector P2 on the OSCD logic board. The level in the fill-pipe will drop quickly. Add more coolant so the level is maintained at ½ inch from the top of the pipe. Continue to run the pump for 15 minutes, adding more coolant as needed, then reinstall P2, make certain the level is ½ inch from the top, and install the pipe plug in the header pipe using teflon tape to assure coolant does not evaporate through the pipe threads. Do not wrap the threads with more than 2 wraps of Teflon tape. To much tape can cause the fill pipe to crack.

4. The BRAM on the ACC board should be cleared to ensure that the surge map is clean, and no data is stored that may cause the OSCD from slowing down. **This procedure should not be performed on a regular basis, and will cause extra surging of the compressor.**

- Enter an Access Code of 1397
- Enter Program Mode
- Press the CHILLED LIQUID TEMPS key under the DISPLAY section. The following message shall appear:

Message: BRAM OPTION :

- Enter the number 368 (the value will be replaced with stars on the display) then press the ENTER key, the following message shall appear.

Message: BRAM OPTION IN PROGRESS . . .

- While the above message is present press and hold SW1 push button on the ACC board for 3 seconds. If the button is not pressed within 20 seconds the option will be aborted. The switch is located at the left center of the board. The following message shall appear.

Message: BRAM OPTION COMPLETE

- To verify that the surge map is cleared check that the vane position no longer reads 0 and now displays X.
5. The vanes must now be calibrated. The pot itself was previously installed, and should have been set so that neither end of travel runs up against either end-stop of the pot. The closed end of the pot should be set for a feedback voltage somewhere between 0.3 and 0.7 VDC, as measured from the wiper (white wire) to common (black wire). The full-open feedback voltage must be greater than the closed value by 0.1 VDC. For example, you might get a range of 0.54 VDC closed, to 1.12 VDC at full open. This range of voltage will be scaled by the Adaptive Capacity Control Board (ACC) to a range of 0% to 100%. The ACC will store the voltage that corresponds with the percentage of vanes in it's BRAM chip.

This scaling is accomplished by an automatic calibration routine in the Micro Computer Control Center. To perform the auto-calibration preform the following:

- Enter an Access Code of 1380
- Change the operating mode of the Micro Computer Control Center to the VSD Service Mode (not Service mode)
- Check to ensure that the Micro Computer Control Center is in the Program Mode
- Press the Open key.
- A message will appear on the display, "Calibration in Progress - Vanes Opening"
- The vanes will run to the full open position and stop.
- After a few seconds, a message will appear on the display, "Calibration in Progress - Vanes Closing"
- The vanes will run to the full closed position and stop.
- A message will appear on the display, "Calibration Successful"
- If so, press the Enter key to accept this calibration. Calibration is not accepted unless the Enter key is depressed.

If "Calibration Successful" is not achieved, then press the cancel key to abort the procedure. Verify the operation of the vane arm, vane pot. the cable between the vane pot and the ACC board, and that the shield of the vane pot. is connected to the OptiView Control Panel enclosure.

If any difficulty is encountered with these procedures, refer to the other sections of this publication for solutions.

THIS PAGE INTENTIONALLY LEFT BLANK.

SECTION 8 - TROUBLESHOOTING AND COMPONENT REPLACEMENT PROCEDURES

GENERAL INFORMATION

The following procedures are designed to guide the service technician along the path that leads to the identification of the cause for the problem. The service technician should understand the operation of the OptiSpeed Compressor Drive and function of each major component. It is recommended that the service technician read and understand the information contained in this instruction prior to troubleshooting this product. Also, the service technician must understand the system interface, and be able to utilize system wiring diagrams to follow signal flow throughout the system. Due to the integration of the OptiSpeed Compressor Drive with the Graphic Control Center and Micro Computer Control Center, a good working knowledge of the Control Center is also necessary (Ref. Forms listed at the beginning of this form).

Several levels of documentation are required for the troubleshooting process. The OptiSpeed Compressor Drive wiring diagram, supplied with every OSCD is the top level document. It provides the overall wiring and configuration. Sections of this instruction provide the required lower levels. Specifically, block diagrams provide signal flow and simplified representations of all board circuitry.

Begin the troubleshooting process by selecting the appropriate procedure. It is not necessary to sequentially perform all of them. Perform a procedure only if there is a problem with that function.

The same procedure is used regardless if the drive model is VSD or LVD.

VERIFY FAILURE OF THE OSCD POWER MODULE 270/292/351/424 HP DRIVE

General Information



This product contains voltages that could cause injury! Before performing any of these procedures, place the compressor switch in the “stop” position. Wait 5 minutes. Ensure the DC bus voltage is 50 vdc or less on the display of the chiller panel. Remove all ac power sources and perform lockout tagout procedures. Use a non-contact voltage sensor to ensure no ac power is present in the enclosure. Measure the DC bus voltage at J3 pins 1-3 on the LCD logic board using a DVM to ensure the bus voltage is less than 50 VDC.

- Be certain the OSCD has been de-energized for over five minutes, and then double check for presence of voltage using a VOM. The DC bus must be fully discharged.
- It is not necessary to remove any wiring to perform this test.
- This test will be conducted for an analog meter and a digital meter. The analog meter must be adjusted to ohms on the Rx1 scale, and the meter should be adjusted for a 0 ohm reading with the probes connected together. The digital meter must be adjusted for the diode check. In this test we are not looking for an exact resistance measurements, but rather to verify if the semi-conductor switches are open or shorted.

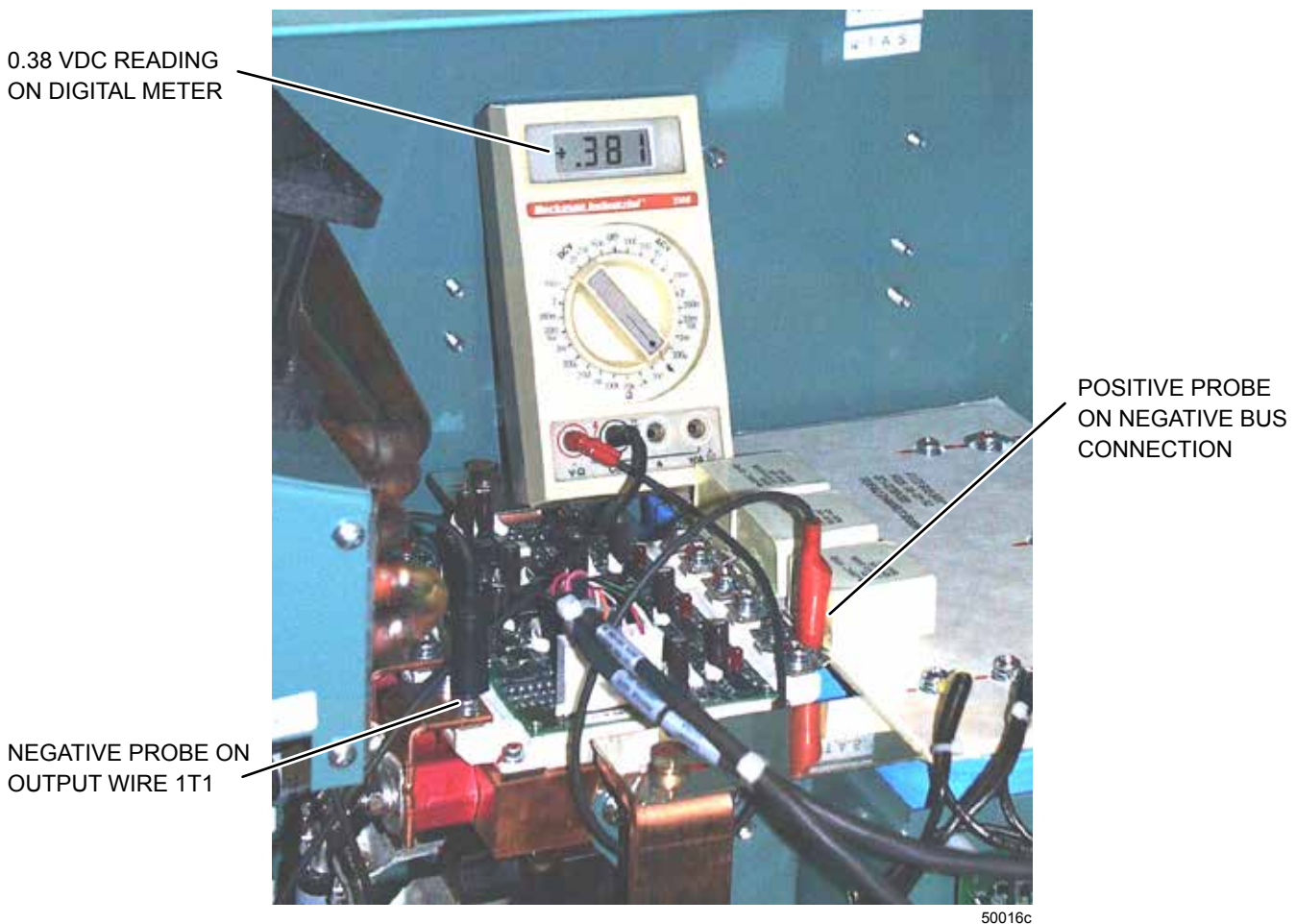

FIGURE 47 - 270/292/351/424 HP DRIVE IGBT MODULE VERIFICATION #1

Test Procedure

Place the positive probe of the meter on the first right hand terminal of the IGBT module. This is the negative bus connection. Place the negative probe of the meter on the first left hand terminal of the IGBT module. The wire should be marked 1T1. The analog meter reading will be around 5-10 ohms. The digital meter reading will be around 0.36 VDC. Refer to *Figure 15*.

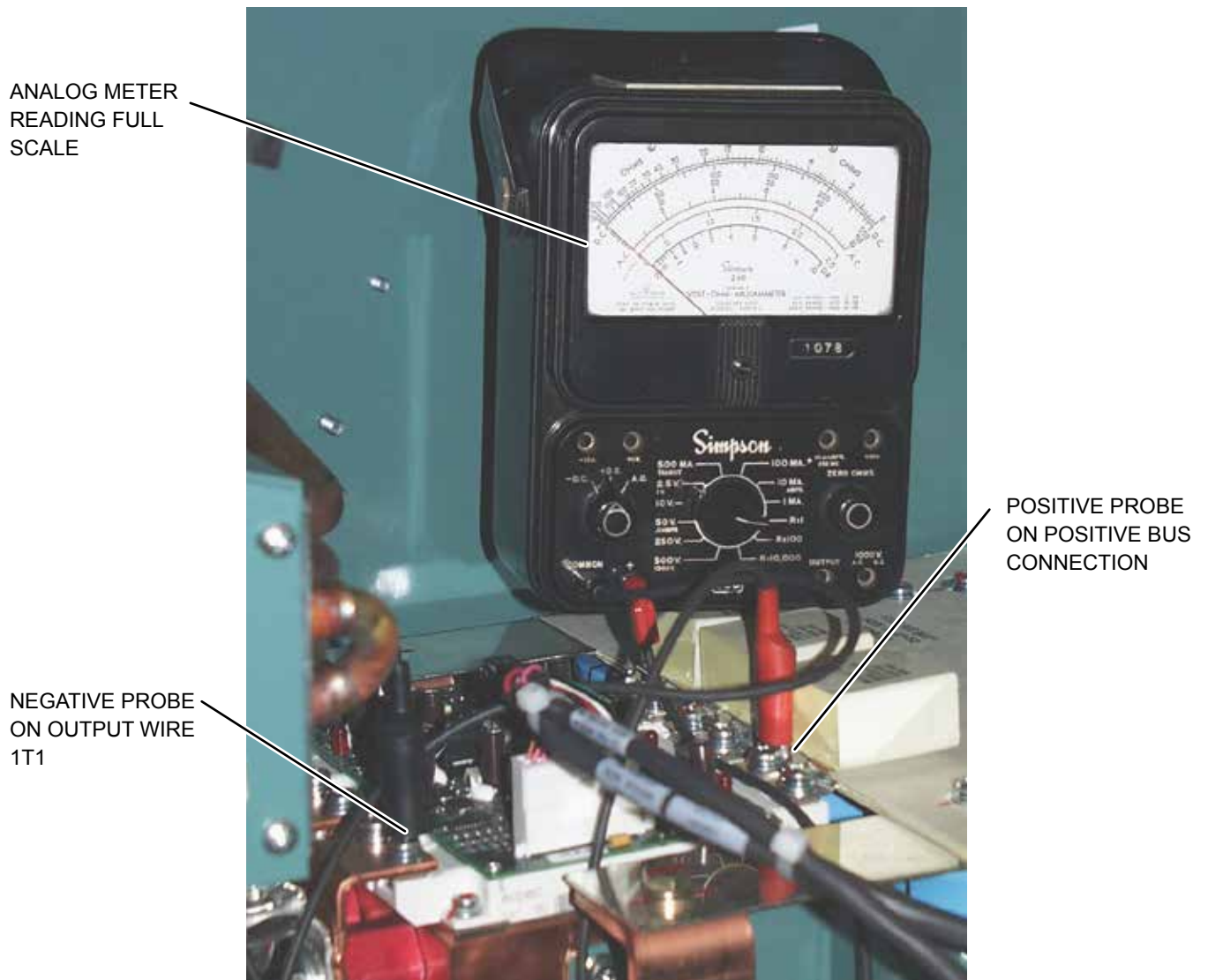

FIGURE 48 - 270/292/351/424 HP DRIVE IGBT MODULE VERIFICATION #2.

Place the positive probe of the meter on the second right hand terminal of the IGBT module. This is the positive bus connection. The analog meter reading will be near full scale to the left of the meter movement. The digital meter reading will be OL. These 2 readings will take several seconds for the meter to reach the suggested values. Refer to *Figures 16* and *Figure 49* on page 132.

Place the positive probe of the meter on the 3rd right hand terminal of the IGBT module. This is the negative bus connection. Place the negative probe of the meter on the 3rd left hand terminal of the IGBT module. The wire should be marked 1T2. The analog meter reading will be around 5-10 ohms. The digital meter reading will be around 0.36 VDC.

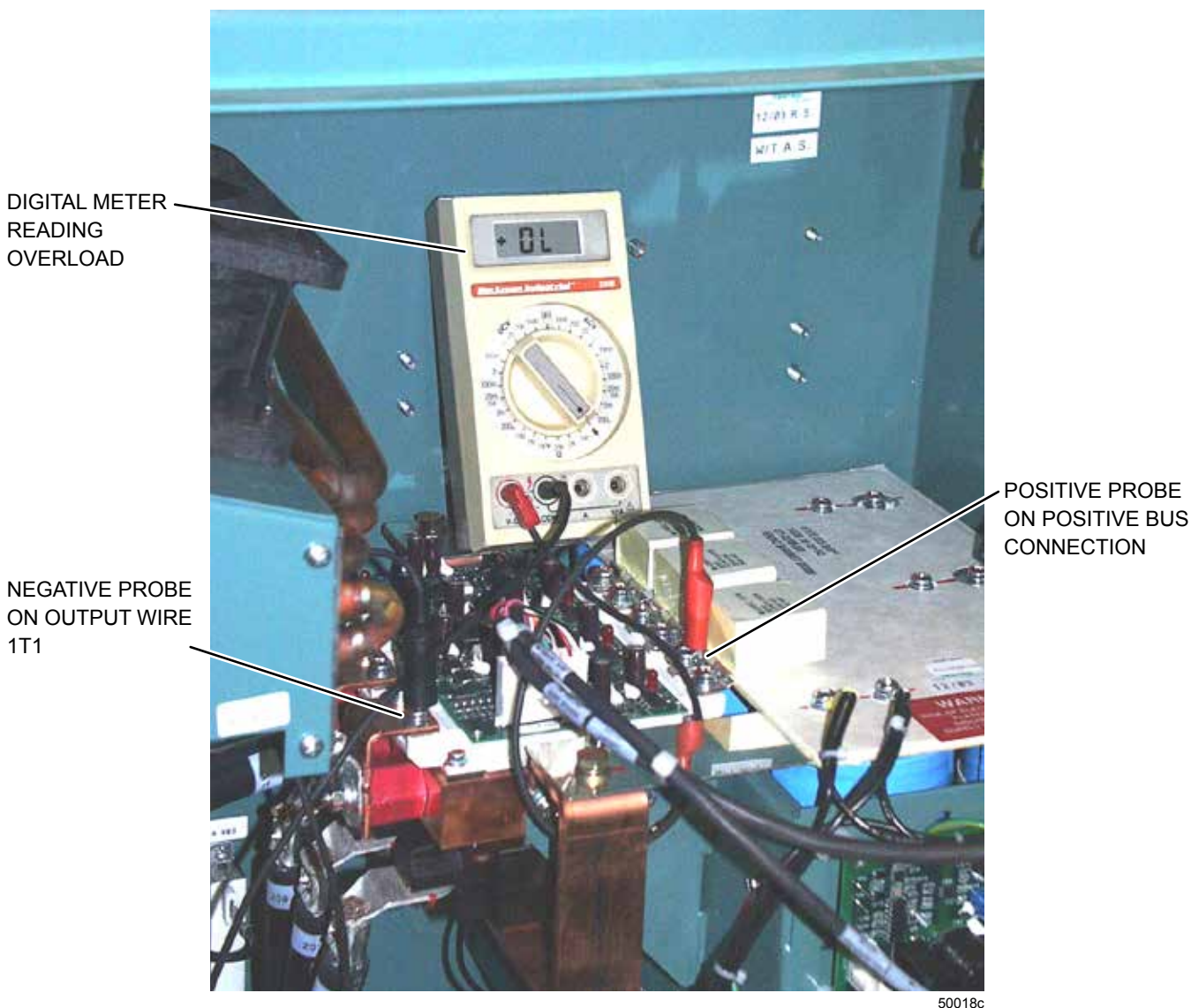

FIGURE 49 - 270/292/351/424 HP DRIVE IGBT MODULE VERIFICATION #3.

Place the positive probe of the meter on the 4th right hand terminal of the IGBT module. This is the positive bus connection. The analog meter reading will be near full scale to the left of the meter movement. The digital meter reading will be OL. These two readings will take several seconds for the meter to reach the suggested values.

Place the positive probe of the meter on the 5th right hand terminal of the IGBT module. This is the negative bus connection. Place the negative probe of the meter on the 5th left hand terminal of the IGBT module. The wire should be marked 1T3. The analog meter reading will be around 5-10 ohms. The digital meter reading will be around 0.36 VDC.

Place the positive probe of the meter on the 6th right hand terminal of the IGBT module. This is the positive bus connection. The analog meter reading will be near full scale to the left of the meter movement. The digital meter reading will be OL. These two readings will take several seconds for the meter to reach the suggested values.

Repeat the above 6 steps, but reverse the location of the positive and negative probes of the meter. The readings will also be reverse as in where the reading are OL or full scale the readings will be 0.36 VDC or 5-10 ohms.

If any one of the readings is not correct, then the IGBT module and gate driver board must be replaced.



50019c

FIGURE 50 - 385/419/503/608/658/704/900 HP DRIVE IGBT MODULE VERIFICATION #1

Verify Failure of the OSCD Power Module 385/419/503/608/658/704/900 Hp Drive

General Information

Refer to information under verify failure of the OSCD power module for general information.

Test Procedure

Place the positive probe of the meter on the first left hand terminal of the IGBT module. This is the positive bus connection. Place the negative probe of the meter on the large copper motor output connection of the IGBT module. The wire should be marked 1T3. The analog meter reading will be near full scale to the left of the meter movement. The digital meter reading will be OL. These 2 readings will take several seconds for the meter to reach the suggested values. Refer to *Figure 18*.

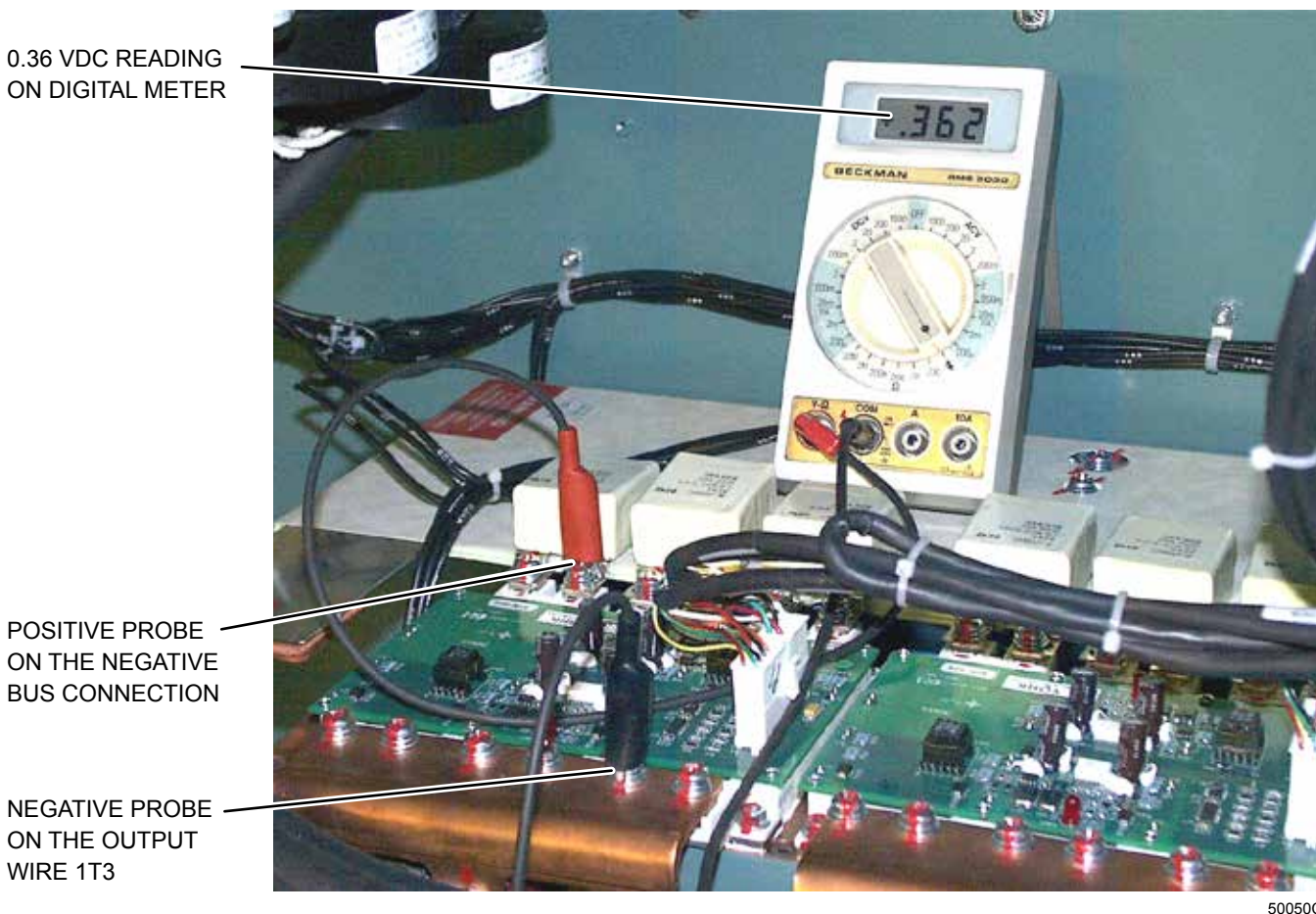

50050C

FIGURE 51 - 385/419/503/608/658/704/900 HP DRIVE IGBT MODULE VERIFICATION #2

Place the positive probe of the meter on the second left hand terminal of the IGBT module. This is the negative bus connection. The analog meter reading will be around 5-10 ohms. The digital meter reading will be around 0.36 VDC. Refer to *Figure 19*.

Place the positive probe of the meter on the first left hand terminal of the IGBT module. This is the positive bus connection. Place the negative probe of the meter on the large copper motor output connection large copper motor output connection of the IGBT module. The wire should be marked 1T2. The analog meter reading will be near full scale to the left of the meter movement. The digital meter reading will be OL. These two readings will take several seconds for the meter to reach the suggested values.

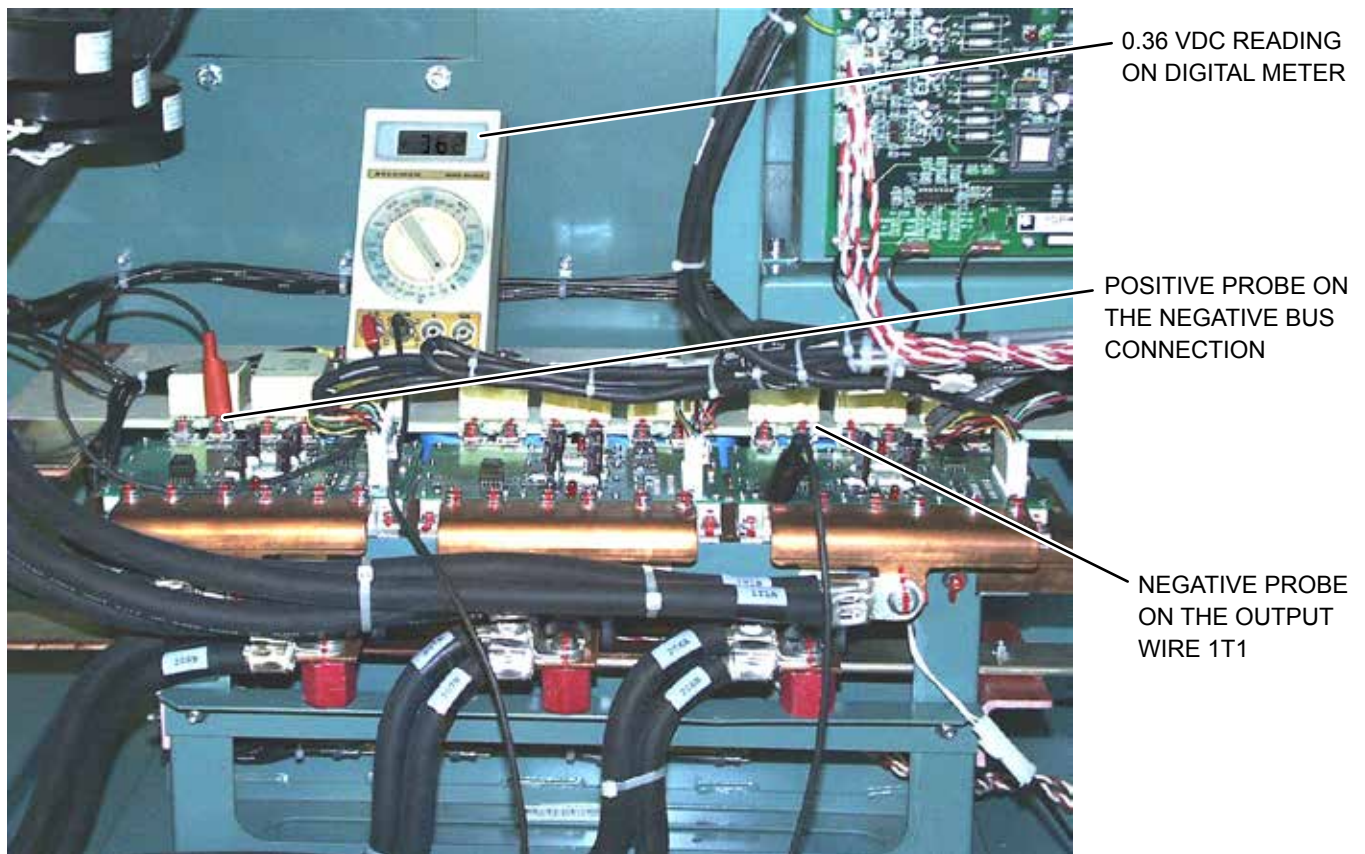

FIGURE 52 - 385/419/503/608/658/704/900 HP DRIVE IGBT MODULE VERIFICATION #3

Place the plus probe of the meter on the second left hand terminal of the IGBT module. This is the negative bus connection. The analog meter reading will be around 5-10 ohms. The digital meter reading will be around 0.36 VDC.

Place the positive probe of the meter on the first left hand terminal of the IGBT module. This is the positive bus connection. Place the negative probe of the meter on the large copper motor output connection large copper motor output connection of the IGBT module. The wire should be marked 1T1. The analog meter reading will be near full scale to the left of the meter movement. The digital meter reading will be OL. These 2 readings will take several seconds for the meter to reach the suggested values.

Place the positive probe of the meter on the second left hand terminal of the IGBT module. This is the negative bus connection. The analog meter reading will be around 5-10 ohms. The digital meter reading will be around 0.36 VDC. Refer to *Figure 20*.

Repeat the above steps, but reverse the location of the positive and negative probes of the meter. The readings will also be reverse as in where the reading are OL or full scale the readings will be 0.36 VDC or 5-10 ohms.

If any one of the readings is not correct, then the IGBT module must be replaced.

Verify Failure of the Harmonic Filter Module 270/292/351/424 and 385/419/503/608/658/704 Hp Drive

General Information

Refer to information under verify failure of the OSCD power module for general information.

This test is the same for all horsepower drives. In the 270/292/351/424 Hp the harmonic filter power unit is mounted at the bottom right of the drive. In the 385/419/503/608/658/704 Hp the harmonic filter power unit is mounted at the center right of the drive. Refer to figures under the section for the 270/292/351/424 Hp for details.

Test Procedure

- Place the positive probe of the meter on the first right hand terminal of the IGBT module. This is the negative bus connection. Place the negative probe of the meter on the first left hand terminal of the IGBT module. The wire should be marked 517. The analog meter reading will be around 5-10 ohms. The digital meter reading will be around 0.36 VDC.
- Place the positive probe of the meter on the second right hand terminal of the IGBT module. This is the positive bus connection. The analog meter reading will be near full scale to the left of the meter movement. The digital meter reading will be OL. These 2 readings will take several seconds for the meter to reach the suggested values.
- Place the positive probe of the meter on the 3rd right hand terminal of the IGBT module. This is the negative bus connection. Place the negative probe of the meter on the 3rd left hand terminal of the IGBT module. The wire should be marked 518. The analog meter reading will be around 5-10 ohms. The digital meter reading will be around 0.36 VDC.
- Place the positive probe of the meter on the 4th right hand terminal of the IGBT module. This is the positive bus connection. The analog meter reading will be near full scale to the left of the meter movement. The digital meter reading will be OL. These 2 readings will take several seconds for the meter to reach the suggested values.
- Place the positive probe of the meter on the 5th right hand terminal of the IGBT module. This is the negative bus connection. Place the negative probe of the meter on the 5th left hand terminal of the IGBT module. The wire should be marked 519. The analog meter reading will be around 5-10 ohms. The digital meter reading will be around 0.36 VDC.
- Place the positive probe of the meter on the 6th right hand terminal of the IGBT module. This is the positive bus connection. The analog meter reading will be near full scale to the left of the meter movement. The digital meter reading will be OL. These 2 readings will take several seconds for the meter to reach the suggested values.
- Repeat the above 6 steps, but reverse the location of the positive and negative probes of the meter. The readings will also be reverse as in where the reading are OL or full scale the readings will be 0.36 VDC or 5-10 ohms.
- If any one of the readings is not correct, then the IGBT module must be replaced.

Replacement of the OSCD Power Module

The following step by step procedure includes several helpful hints which should make the process easier, and minimize the possibility of damage to other components or to the OSCD.

Save all of the packing material. This material is to be re-used when returning a defective power module as required for warranty.



This product contains voltages that could cause injury! Before performing any of these procedures, place the compressor switch in the “stop” position. Wait 5 minutes. Ensure the dc bus voltage is 50 vdc or less on the display of the chiller panel. Remove all ac power sources and perform lockout tagout procedures. Use a non-contact voltage sensor to ensure no ac power is present in the enclosure. Measure the dc bus voltage at j3 pins 1-3 on the lcd logic board using a dvm to ensure the bus voltage is less than 50 vdc.

- Be certain the OSCD has been de-energized for over five minutes, and then double check for presence of voltage using a VOM. The DC bus must be fully discharged.
- 270/292/351/424 Hp Drive Only: Drain the coolant from the heat exchanger into a suitable container and discard.

- Remove the connector on the IGBT Gate Driver Board.
- Remove and discard the 6 Phillips head screws from the power wire connector tang or tangs, and the remaining 6 Phillips head screws from the bus connections.
- Remove the bolt holding the power wire to the output of the IGBT.
- Remove and discard the 8 Allen screws from the IGBT module.
- **270/292/351/424 Hp Drive Only:** Carefully remove the OSCD power module by sliding it away from the bus structure while lifting slightly. **DO NOT** place any stress on the bus structure. The bottom of the IGBT module will be wet. Ensure that the coolant does not drip onto any other components inside of the OSCD enclosure. This coolant is **conductive**, and as little as one drop falling on the Harmonic Filter gate driver board can cause it to fail!
- **270/292/351/424 Hp Drive Only:** Remove the 3 O-rings from the copper chill plate and discard them.
- **270/292/351/424 Hp Drive Only:** Wipe the chill plate clean with a clean soft cloth. **DO NOT** leave lint or any materials on the chill plate. **DO NOT** clean using compressed air.
- **270/292/351/424 Hp Drive Only:** Lightly lubricate the new O-rings with O-ring lubricant. Provided in the kit.
- **270/292/351/424 Hp Drive Only:** Install the new Orings into the chill plate grooves.
- **270/292/351/424 Hp Drive Only:** Place the new OSCD power module on the chill plate so that the connector is towards the front of the OSCD enclosure. Carefully slide the OSCD power module power connections under the bus structure. The replacement assembly should still be loose.
- **385/419/503/608/658/704/900 Hp Drive Only:** Carefully remove the OSCD power module by sliding it away from the bus structure while lifting slightly. **DO NOT** place any stress on the bus structure.
- **385/419/503/608/658/704/900 Hp Drive Only:** Wipe the chill plate clean with a clean soft cloth. **DO NOT** leave lint or any materials on the chill plate. **DO NOT** clean using compressed air. Rubbing alcohol works well to remove the thermal grease from the chill plate.
- **385/419/503/608/658/704/900 Hp Drive Only:** Apply a thin coat of thermal grease on to the back side of the IGBT module. The thermal grease should be provided in the service kit.
- **385/419/503/608/658/704/900 Hp Drive Only:** Place the new OSCD power module on the chill plate so that the connector is towards the right of the OSCD enclosure. Carefully slide the OSCD power module power connections under the bus structure. The replacement assembly should still be loose.
- Insert the 8 Allen head screws through the new IGBT module and engage a few threads in the chill plate, but **DO NOT** tighten. The new OSCD power module should still be loose.
- Align the OSCD power module so that 6 of the Phillips head screws can be installed through the bus structure and into the IGBT module. **DO NOT** tighten these screws.
- Tighten the Allen head screws to 48 in.-lbs. (5.5 Nm) \pm 10% in the sequence shown in *Figure 21*.

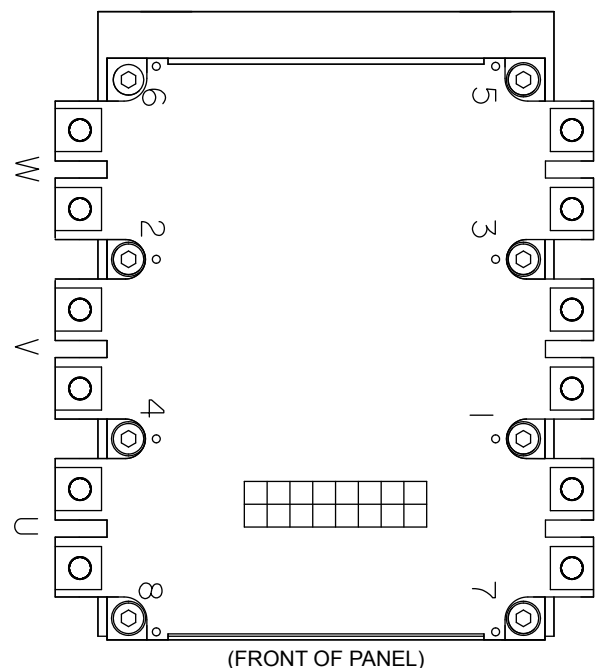

SCREWS TO BE TORQUED IN SEQUENCE - 1, 2, 3, 4, 5, 6, 7, 8
LD07412

FIGURE 53 - OSCD POWER MODULE

- Install the power wire connector tang or tangs using 6 Phillips head screws, and torque the screws to 48 in.-lbs. (5.5 Nm) \pm 10%. If a copper output power tang or tangs are used install them with the bolt that was saved. Torque the bolt to 40-50 in.-lbs. Then install the 6 Phillips head screws, and torque the screws to 48 in.-lbs. (5.5 Nm) \pm 10%.
- Remove the 6 Phillips head screws (not yet tightened) at the bus structure and install the 3 square capacitors to the bus structures with these screws. Torque the screws to 48 in.-lbs. (5.5 Nm) \pm 10%.
- Install the connector on the IGBT Gate Driver Board.
- **270/292/351/424 Hp Drive Only:** Close the drain valve on the heat exchanger and refill the system with the coolant supplied and check for leaks.
- **270/292/351/424 Hp Drive Only:** Follow the directions included in the Start-Up Preparations for running the OSCD's water pump to ensure all entrapped air is vented and the cooling loop is properly filled.

Replacement of the Harmonic Filter Power Module

The procedure to replace the harmonic filter power module is the same as for the replacement of the OSCD Power Module, except for the following.

- **270/292/351/424 Hp Drive Only:** On early models of the OSCD compressor drive the cooling system did not properly drain out of the Harmonic Filter Power Module. Early models can be determined by look at the far end of the heat exchanger. If the three hoses are connected to a 6 inch plastic riser pipe, then this is the style that will not properly drain.
- **270/292/351/424 Hp Drive Only:** Drain the coolant as described above. Then remove one of the coolant hoses feeding the Harmonic Filter Power Module. Failure to completely drain the coolant system will cause coolant to leak into the VSD enclosure.
- **385/419/503/608/658/704 Hp Drive Only:** The IGBT module for the harmonic filter power unit is installed in the same manner as the 270/292/351/424 Hp drive, but will not have the draining problems.

In-Warranty Parts Return – Any OSCD parts failing within the standard warranty period must be returned. Refer to YORK Warranty Return Policy for instructions.

VSD FREQUENTLY ASKED QUESTIONS

Why doesn't the measured input amps of the OSCD agree with the rated FLA?

The input current to the OSCD may be considerably lower, compared to the output current. This is due to the power factor at the input to the OSCD being greater than .95, and nearly unity when the Harmonic Filter option is included. Chiller FLA must be measured at the motor terminals, where the power factor is the normal motor power factor. Use a true RMS reading meter to make these measurements.

How can I manually control the speed of the drive?

For the OptiView Control Panel, first enter the Service Access Level. Select the VSD Tuning Screen from the Compressor Screen. From this screen the speed of the drive can be set to a specific frequency, raise or lowered by a specific amount of frequency, or set for fixed speed (60Hz). Press the AUTO key to return speed control to the ACC board.

For the Micro Computer Control Center, first enter the VSD Service mode. Once in the VSD Service mode, make certain you are NOT in program mode by pressing the program button and watching the display. With the panel NOT in program, you can adjust the frequency setpoint using the increment and decrement keys which are combined with the vanes open and closed buttons. You can also select fixed 60HZ by pressing the 60HZ key. The OSCD will begin to change speed, moving toward the manual setpoint you entered. It may take some time to attain the programmed frequency. To exit the manual OSCD speed mode, press the Auto key. Be sure the unit is in Auto speed mode before exiting the VSD service mode, otherwise the unit will stay in the manual speed mode after exiting the VSD service mode.

How can the Pre Rotation Vanes be manually controlled when an OptiSpeed Compressor Drive is installed?

Regardless of which control center is used, the method of manual vane control remains the same as with a fixed speed chiller. Refer to the appropriate chiller Service Manual for these controls.

On a retrofit OptiSpeed Compressor Drive, what is the DV/DT Network for?

The combination of long runs of wire between the OSCD and the compressor motor, with the fast rise

time of the output voltage of the OSCD can cause excessively high voltage potential at the motor terminals. Without the DV/DT Network, the insulation in the compressor motor may be overly stressed. The DV/DT Network reduces the high voltage potential to below the motor's voltage specification. The design of the DV/DT network currently in production has a requirement for installation on top of the motor terminal box. DO NOT add any additional wire between the motor terminal connections and the DV/DT Network. The additional wire will reduce the DV/DT Network's effectiveness, and potentially shorten the life of the motor.

On all OSCD's, a similar circuit is located on the back wall of the OSCD enclosure near the motor connections. Since this filter is already present inside the cabinet on all OSCD, some installers have questioned whether the internal circuit must be disabled when using the terminal box mounted accessory. The answer is no - you do not need to disconnect the DV/DT network inside the OSCD cabinet.

Is a Condenser Water Strainer used with the shell and tube heat exchanger?

Since the shell and tube heat exchanger can be cleaned with a rifle brush, no extra precautions are needed to keep the heat exchanger clean. No strainer is provided with this OSCD. The intent is to have the heat exchanger cleaned annually. Gaskets are available (refer to the service parts list).

What is the timing of the Anti-Recycle when an OSCD is applied?

The anti-recycle time is much quicker with an OSCD than with a starter. The reason is the elimination of inrush current on start-up. The OptiSpeed compressor drive slowly accelerates the compressor motor so that the motor does not consume more than 100% of the motor's nameplate full load amps. The anti-recycle time is five (5) starts in succession, followed by a ten minute wait. After ten minutes, you get five more successive starts. This is permitted on OSCD units only, due to the low current draw and reduced motor heating during startup.

Why does the condenser pressure transducer on a YT chiller need to be changed when an OSCD is applied?

For the OptiSpeed compressor drive to perform well it requires cooler condenser water. The cooler condenser water lowers the condenser pressure below the standard condenser pressure transducer's range. Thus, a

new pressure transducer is required with a wider range of pressure. The new pressure transducer part number is 025-29148-009. Its range is 4 to 34 PSIA, with a proportional output of 0.5 to 4.5 VDC. The OSCD software for YT chillers require the use of this transducer.

What is the proper wire sizing when using an OptiSpeed Compressor Drive?

The input power wires to the OSCD are sized at 1.25 times the full-load amps of the compressor motor, plus oil pump amps and control transformer amps. Note this differs from the 1.38 multiplier used on earlier drives. OptiSpeed compressor drive to Compressor Motor wires need only be 1.25 times the compressor motor FLA, since the oil pump and control power are not part of the equation at this point.

Does the surge counter reflect the number of points in the surge map?

No, the surge counter increments each time the ACC detects a chiller surge, not each time a surge is added to the map. It is not uncommon to receive a chiller with some number of surges recorded in memory. The only way to zero this value is to zero the BRAM memory which stores the compressor surge map and other non-volatile data. Zeroing of the BRAM generally is not done unless some condition has caused false data to be stored - see section titled "Zeroing BRAM" below. Also, be aware it is not uncommon to find very high numbers of surges. We had one chiller which surged for two weeks, running 60 HZ, along with a fixed-speed chiller which was also surging due to tower problems. After two weeks, the customer decided it was time to fix the tower! In this case we logged over 18,000 surges.

Under what conditions should I zero the BRAM on the ACC board?

An internal lithium battery maintains the BRAM memory even if the power is removed. This chip is located on the ACC board. It stores the compressor surge map information, and other data such as the vane pot calibration. There are only 3 reasons where this memory should be cleared - when the chiller has been running and storing invalid surge information due to a mis-calibrated vane pot, when the chiller has been running and storing invalid data due to a faulty condenser or evaporator transducer, and when the chiller is first started with an OSCD. Vane position and refrigerant pressures are two of the three pieces of information stored in the surge map, and if these values are false, the map created with false information will be a false map.

Any other conditions which may be abnormal will only cause the chiller to run at an abnormal part of the map, but will still be valid data for the conditions. For example, if the cooling tower should by-pass water, causing a false high-head, the ACC will figure out the best mode of operation for these conditions, even though they are abnormal. When the problem with the tower is fixed, the ACC will determine a new optimum operation on a different part of the map. Neither set of stored values is incorrect. If the same tower problem ever develops again, the chiller will already know what to do. If you believe you need to zero the BRAM, call YORK factory service for assistance.

Should I require the customer to install isolation between the Power Conduits and the OptiSpeed Compressor Drive?

We no longer require a section of non-metallic conduit at the entrance and exit to/from the OSCD as we did on previous products. If any customer or installer wishes to continue to follow this practice, we have no objections.

How does the MicroComputer Control Center provide power to the ACC board?

The ACC board is power by +30 VDC unregulated from the control center's power supply board. There are two connectors on this power supply which can furnish +30 VDC unregulated. The plug designated in the retrofit drawings is sometimes already being used by the liquid level control. It is permissible to daisy chain off this same wiring, or you may elect to utilize the alternate +30 VDC unregulated connection.

What instructions do I use to install a retrofit OptiSpeed Compressor Drive?

There are 3 drawings shipped with each retrofit kit. These drawings are:

- Vane Pot Installation and Set-Up
- Piping Installation
- Control Panel Retrofit

How do I connect a 12 lead motor to a OptiSpeed Compressor Drive?

Most of these 12 lead motors actually have two sets of parallel windings, and therefore have two one's, two two's, etc. OSCD's and Solid-State Starters are connected to the motor in the delta configuration, that is 1 and 6, 2 and 4, 3 and 5. The T1 lug will then have two one's and two sixes tied to it.

There were a few motors, made several years ago, which were numbered 1 through 12. These motors had the first set of wires marked 1 to 6. Numbering then continued, with the second 1 numbered 7, the second 2 numbered 8, and so on, up to 12. In other words, take the numbers above six, subtract 6 from the number, and re-label as the result.

What is the Peak Input Voltage value?

The displayed value is the Phase to Neutral voltage at the input to the drive in terms of peak voltage, as would be measured with an oscilloscope.

Phase to neutral is normally the phase-to-phase voltage divided by the square root of three, or 265 VAC phase to neutral, for a 460 VAC system. The peak value of the 265 VAC measurement is approximately that number times the square root of two, or 375 volts in this example.

How do I reset the KWH Meter?

For the OptiView Control Panel, first enter the Service Access Level. Select the VSD Screen. Press the KWH key, and select the default selection. The KWH value will now be zero.

For the Micro Computer Control Center, first enter the “VSD Service Mode”, making sure the Control Center is in “Program Mode”, and pressing the “Operating Hours / Start Counter” button. The display will show, “Reset Hours? Y/N”. Use the advance day / Scroll key to select “Y”, and press “Enter”. The KWH value will now be zero.

Is the Real Time Clock Chip on the microboard and the BRAM Chip on the ACC and OSCD logic boards the same chip?

If you are familiar with the RTC Clock chip used on the control center microboard, you may notice what appears to be clock chips on the ACC board and on the OSCD logic board. These two boards contain similar black plastic chips which are battery backed random access memory (BRAM). They have a different number of pins from the RTC Clock chips, and cannot be replaced by the familiar clock chip.

When is a Booster Pump required on a Retrofit OptiSpeed Compressor Drive?

Detailed information is supplied in *Installation (Form 160.05-N4)*. In general, the OSCD requires 8 ft of head for proper water flow to the OSCD heat exchanger. If this amount of head is not available, then a booster pump is required.

Can I apply an OptiSpeed Compressor Drive to a generator?

Yes, the OSCD can be applied to a generator. No modifications are required for a generator application. We have several OSCD installations running on generator power without difficulty. It is necessary that the generator's output voltage be maintained within the specified range of 414 to 508 VAC for a 460 VAC line, 360 to 440 for a 400 VAC line, or 517 to 632 VAC for a 575 VAC line and frequency be maintained within +/- 1 HZ (on all applications). This is usually not a problem for most generators, since motor current at startup is limited to less than 1X the Full Load Amps (FLA). The transfer of power between the utility and generator and back again must be delayed a minimum of 10 seconds to cause the chiller to fault and then restart. Not providing this delay may cause failure within the OSCD or instability within the generator.

My chiller will not slow down, why?

The OSCD will not reduce the motor speed until the leaving chilled water temperature is below +0.5 degree from setpoint. Once in this window, the speed still cannot be reduced until the operation is deemed to be stable, based upon the vanes are not continually moving open and closed to maintain temperature. This hunting effect is normally due to one of the following:

- Chilled liquid and Condenser liquid flows are not within the design range. The rate of change in flow maybe too fast for the chiller to be determined as stable.
- Return liquid temperature is varying due to 3-way valves or other system configuration, and the chiller is simply following changes in load.
- Vane stroke is too large. Remove the sensitivity jumper in the Micro Computer Control Center, or program a lower sensitivity on the OptiView Control Center. Also, check the vane motor to see that the fullest possible stroke is being utilized. Moving the vane motor arm pivot point closer to center, and extending the degrees of travel by adjusting the internal end stops, will reduce the amount of vane action for the same period of operation.
- Verify that the condenser tubes are clean.
- Verify that the liquid level control is working properly, and maintaining a refrigerant level in the condenser.
- Ensure that the condenser liquid temperature is proper for the load on the chiller. In many cases, the condenser liquid temperature is still at 85°F.

Failure to reduce speed may also be due to the system having been placed in Manual Speed when in VSD Service Mode. Other causes are a missing or disconnected wiring harness at ACC board J3, or a faulty ACC board itself.

What is the function of the Green LED on ACC Board?

This LED will light if:

- The system is in Manual speed control.
- The chiller is running in current limit.
- The leaving chilled liquid temperature is greater than +0.5 of setpoint.
- The rate of change in temperature of the leaving chilled water is greater than that programmed by the stability limit function.
- The chiller is not running.

I believe that the chiller is surging, but the surge counter is not increasing. What could be the problem?

When a surge is detected, the ACC board will light the red LED. Failure to light the red LED may be due to one of the following:

- The condition is “Stall”, Not Surge - Stall is a very noisy condition which is due to gas pulsations hitting the impeller wheel in a random fashion. System pressures and motor current may fluctuate in brief, random pulses, but this is not a surge. This is normal for a chiller that has reduced speed, but the condenser water temperature is too high. True surge will be characterized by a repeated howling sound, with pressure and motor current swinging in a cyclical manner.
- The wire harness connecting the ACC board J3 to the Micro-board may be missing or disconnected. This harness passes system pressure information to the ACC board.
- The ACC board may be defective.
- The chiller is not running.

Do I have a problem with my coolant? The pink color is no longer visible?

The coolant normally has a pink or rose color when new. After several months of operation, this color may dissipate, and the coolant may appear almost colorless. The lack of the color in the coolant does not necessarily

indicate a problem. Most colorless samples test above 1000 PPM nitrite, which is normal. There is no need to flush the system unless you find the coolant becoming opaque or cloudy. In this case we suggest you obtain a sample for analysis, then flush the system with coolant and install fresh coolant. The coolant must be changed every year regardless of color or test results.

Why is the OSCD Circuit Breaker Tripping?

Circuit breaker tripping is now normal for a failed OptiSpeed Compressor Drive. This drive no longer contains input fuses. The AC choke now reduces the current flowing into the short, and the circuit breaker is now fast enough to provide proper protection. A tripped circuit breaker may be due to a shorted condition inside the drive, or the presence of a ground fault condition, or may be due to the breaker itself being faulty.

Check for shorts at the input and output of the drive. Check for leakage current to ground. This could also be a problem in one of the input SCR's. In some cases, the precharge current may cause the SCR to fail. It was determined in some applications the circuit breaker would trip because the input SCR was falsely turned on by a high rate of change in voltage on the input line. Snubbers were added across the input SCR to prevent this problem. Refer to *Wiring Field Connections (Variable Speed Drive) Replacement Parts List (Variable Speed Drive) (Form 160.00-RP4) (406)* or later for part numbers.

What is the TEST Button for on OSCD Logic Board?

When the OSCD is not running, this button may be used to test operation of the logic outputs from the OSCD logic board, as well as the operation of the gate driver board on the IGBT module. When this button is depressed, six output LEDs on the OSCD logic board alternately light the three plus (+) LEDs, then the three minus (-) LEDs. At the same time, six LEDs on the gate driver board will alternate between dim and bright intensity. Several conditions can inhibit this test function:

- If any OSCD fault exists.
- If the unit is in pre-charge.
- If the SCR trigger is enabled.
- If the OSCD unit is running.
- A 4 minute timer is part of this function to ensure that the DC Link Voltage is discharged to a safe level. This timer must time out before the Test Button will function.

If a new filter logic board is installed in the drive the gate driver LED's on the filter gate driver board will now flash just like the VSD gate driver board. The part

number of the new filter logic board is 031-02932-xxx Rev. A board and later. The production of this board began in 2011.

TABLE 6 - SOFTWARE REFERENCE LIST VSD MODELS

OPTIVIEW CONTROL CENTER MINIMUM VERSIONS REQUIRED FOR THE 270/385 HP 60 HZ 400 VAC DRIVE, AND 292/419 HP 50 HZ 415 VAC DRIVE		
LOCATION	PART NUMBER	MINIMUM VERSION NUMBER
YK Microboard (031-02430-001)	031-02474-001	C.OPT.01.23.307
ACC Board U22	031-01674-002	C.ACC.01.03
OSCD Logic Board (031-02506-xxx) U22	031-03420-001	C.VSD.11.01.04
OSCD Logic Board (031-02506-xxx) U34	031-02547-005	C.VSD.47.01.08
Filter Logic Board (031-01632-xxx) U26	031-01680-003	C.FTR.02.05
Filter Logic Board (031-01632-xxx) U42	031-01633-007	C.FTR.01.19 (50 Hz)
Filter Logic Board (031-01632-xxx) U42	031-01633-006	C.FTR.01.18A (60 Hz)
OPTIVIEW CONTROL CENTER MINIMUM VERSIONS REQUIRED FOR THE 292 HP 50 HZ 400 VAC DRIVE, 351 HP 60 HZ 460 VAC DRIVE		
LOCATION	PART NUMBER	MINIMUM VERSION NUMBER
Microboard (031-01730-xxx) U45	031-01796-003	C.MLM.00.03
YT Microboard (031-01730-xxx) U46	031-02004-001	C.MLM.02.02B.102
YK Microboard (031-01730-xxx) U46	031-01797-001	C.MLM.01.05B.102
YKP Microboard (031-01730-xxx) U46	031-02073-001	C.MLM.04.01B.100
ACC Board U22	031-01674-002	C.ACC.01.03
OSCD Logic Board (031-02077-xxx) U34	031-01617-007	C.VSD.01.14A (50 Hz)
OSCD Logic Board (031-02077-xxx) U34	031-01617-006	C.VSD.01.10 (60 Hz)
OSCD Logic Board (031-02077-xxx) U40	031-01619-003	C.VSD.03.02
OSCD Logic Board (031-02077-xxx) U45	031-01618-002	C.VSD.02.03 (50 Hz)
OSCD Logic Board (031-02077-xxx) U45	031-01618-001	C.VSD.02.02 (60 Hz)
Filter Logic Board (031-01632-xxx) U26	031-01680-003	C.FTR.02.05
Filter Logic Board (031-01632-xxx) U42	031-01633-007	C.FTR.01.15 (50 Hz)
Filter Logic Board (031-01632-xxx) U42	031-01633-006	C.FTR.01.14 (60 Hz)
OPTIVIEW CONTROL CENTER MINIMUM VERSIONS REQUIRED FOR THE 419 HP 50 HZ 400 VAC DRIVE, 503 HP 60 HZ 460 VAC DRIVE		
LOCATION	PART NUMBER	MINIMUM VERSION NUMBER
Microboard (031-01730-xxx) U45	031-01796-003	C.MLM.00.03
YT Microboard (031-01730-xxx) U46	031-02004-001	C.MLM.02.04.104
YK and YKP Microboard (031-01730-xxx) U46	031-01797-001	C.MLM.01.08.105
ACC Board U22	031-01674-002	C.ACC.01.03
OSCD Logic Board (031-02077-xxx) U34	031-01617-007	C.VSD.01.14A (50 Hz)
OSCD Logic Board (031-02077-xxx) U34	031-01617-006	C.VSD.01.13A (60 Hz)
OSCD Logic Board (031-02077-xxx) U40	031-01619-003	C.VSD.03.04
OSCD Logic Board (031-02077-xxx) U45	031-01618-002	C.VSD.02.03 (50 Hz)
OSCD Logic Board (031-02077-xxx) U45	031-01618-001	C.VSD.02.02 (60 Hz)
Filter Logic Board (031-01632-xxx) U26	031-01680-003	C.FTR.02.05
Filter Logic Board (031-01632-xxx) U42	031-01633-007	C.FTR.01.19 (50 Hz)
Filter Logic Board (031-01632-xxx) U42	031-01633-006	C.FTR.01.18 (60 Hz)

TABLE 6 - SOFTWARE REFERENCE LIST VSD MODELS (CONT'D)

OPTIVIEW CONTROL CENTER MINIMUM VERSIONS REQUIRED FOR THE 424/608 HP 60 HZ 575 VAC DRIVE		
LOCATION	PART NUMBER	MINIMUM VERSION NUMBER
YT Microboard (031-02430-001)	031-02469-001	C.OPT.02.09.008
YK Microboard (031-02430-001)	031-02474-001	C.OPT.01.15A.307
ACC Board U22	031-01674-002	C.ACC.01.03
OSCD Logic Board (031-02077-xxx) U34	031-01617-009	C.VSD.01.23
OSCD Logic Board (031-02077-xxx) U40	031-01619-003	C.VSD.03.02
OSCD Logic Board (031-02077-xxx) U45	031-01618-001	C.VSD.02.02
Filter Logic Board (031-01632-xxx) U26	031-01680-003	C.FTR.02.05
Filter Logic Board (031-01632-xxx) U42	031-01633-008	C.FTR.01.20
OPTIVIEW CONTROL CENTER MINIMUM VERSIONS REQUIRED FOR THE 658 HP 50 HZ 400 VAC DRIVE		
LOCATION	PART NUMBER	MINIMUM VERSION NUMBER
YK Microboard (031-02430-001)	031-02474-001	C.OPT.01.23.307
OSCD Logic Board (031-02506-xxx) U22	031W03420-001	C.VSD.11.01.04
OSCD Logic Board (031-02506-xxx) U34	031W02547-002	C.VSD.17.03.00
Filter Logic Board (031-02932-xxx) U42	031W01633-007	C.FTR.01.19
Filter Logic Board (031-02932-xxx) U112	031W02933-003	C.FTR.05.07
OPTIVIEW CONTROL CENTER MINIMUM VERSIONS REQUIRED FOR THE 704 HP 50 HZ 415 VAC DRIVE		
LOCATION	PART NUMBER	MINIMUM VERSION NUMBER
YK Microboard (031-02430-001)	031-02474-001	C.OPT.01.23.307
OSCD Logic Board (031-02506-xxx) U22	031W03420-001	C.VSD.11.01.04
OSCD Logic Board (031-02506-xxx) U34	031W02547-005	C.VSD.47.03.00
Filter Logic Board (031-02932-xxx) U42	031W01633-007	C.FTR.01.19
Filter Logic Board (031-02932-xxx) U112	031W02933-003	C.FTR.05.07
MICRO COMPUTER CONTROL CENTER VERSIONS REQUIRED FOR THE 292 HP 50 HZ 400 VAC DRIVE, 351 HP 60 HZ 460 VAC DRIVE		
LOCATION	PART NUMBER	MINIMUM VERSION NUMBER
YT Microboard (031-01065-xxx) U17	031-01676-002	C.YTV.05.21 (50 Hz)
YT Microboard (031-01065-xxx) U17	031-01676-003	C.YTV.05.20 (60 Hz)
YK Microboard (031-01065-xxx) U17	031-01675-002	C.YKV.06.23 (50 Hz)
YK Microboard (031-01065-xxx) U17	031-01675-003	C.YKV.06.24 (60 Hz)
ACC Board U22	031-01674-002	C.ACC.01.03
OSCD Logic Board (031-02077-xxx) U34	031-01617-007	C.VSD.01.14A (50 Hz)
OSCD Logic Board (031-02077-xxx) U34	031-01617-006	C.VSD.01.10 (60 Hz)
OSCD Logic Board (031-02077-xxx) U40	031-01619-003	C.VSD.03.02
OSCD Logic Board (031-02077-xxx) U45	031-01618-002	C.VSD.02.03 (50 Hz)
OSCD Logic Board (031-02077-xxx) U45	031-01618-001	C.VSD.02.02 (60 Hz)
Filter Logic Board (031-01632-xxx) U26	031-01680-003	C.FTR.02.05
Filter Logic Board (031-01632-xxx) U42	031-01633-007	C.FTR.01.15 (50 Hz)
Filter Logic Board (031-01632-xxx) U42	031-01633-006	C.FTR.01.14 (60 Hz)

TABLE 6 - SOFTWARE REFERENCE LIST VSD MODELS (CONT'D)

MICRO COMPUTER CONTROL CENTER VERSIONS REQUIRED FOR THE 419 HP 50 HZ 400 VAC DRIVE, 503 HP 60 HZ 460 VAC DRIVE		
LOCATION	PART NUMBER	MINIMUM VERSION NUMBER
YT Microboard (031-01065-xxx) U17	031-01676-002	C.YTV.05.23 (50 Hz)
YT Microboard (031-01065-xxx) U17	031-01676-003	C.YTV.05.22 (60 Hz)
YK Microboard (031-01065-xxx) U17	031-01675-002	C.YKV.06.29 (50 Hz)
YK Microboard (031-01065-xxx) U17	031-01675-003	C.YKV.06.30 (60 Hz)
ACC Board U22	031-01674-002	C.ACC.01.03
OSCD Logic Board (031-02077-xxx) U34	031-01617-007	C.VSD.01.14A (50 Hz)
OSCD Logic Board (031-02077-xxx) U34	031-01617-006	C.VSD.01.13A (60 Hz)
OSCD Logic Board (031-02077-xxx) U40	031-01619-003	C.VSD.03.04
OSCD Logic Board (031-02077-xxx) U45	031-01618-002	C.VSD.02.03 (50 Hz)
OSCD Logic Board (031-02077-xxx) U45	031-01618-001	C.VSD.02.02 (60 Hz)
Filter Logic Board (031-01632-xxx) U26	031-01680-003	C.FTR.02.05
Filter Logic Board (031-01632-xxx) U42	031-01633-007	C.FTR.01.19 (50 Hz)
Filter Logic Board (031-01632-xxx) U42	031-01633-006	C.FTR.01.18 (60 Hz)
MICRO COMPUTER CONTROL CENTER VERSIONS REQUIRED FOR THE 424/608 HP 60 HZ 575 VAC DRIVE		
LOCATION	PART NUMBER	MINIMUM VERSION NUMBER
YT Microboard (031-01065-xxx) U17	031-01676-003	C.YTV.05.24
YK Microboard (031-01065-xxx) U17	031-01675-003	C.YKV.06.32
ACC Board U22	031-01674-002	C.ACC.01.03
OSCD Logic Board (031-02077-xxx) U34	031-01617-009	C.VSD.01.23
OSCD Logic Board (031-02077-xxx) U40	031-01619-003	C.VSD.03.04
OSCD Logic Board (031-02077-xxx) U45	031-01618-001	C.VSD.02.02
Filter Logic Board (031-01632-xxx) U26	031-01680-003	C.FTR.02.05
Filter Logic Board (031-01632-xxx) U42	031-01633-008	C.FTR.01.20

TABLE 7 - SOFTWARE REFERENCE LIST LVD MODELS (LVD MODEL ARE ONLY AVAILABLE WITH MODBUS COMMUNICATIONS AND WILL REQUIRE THE OPTIVIEW PANEL)

OPTIVIEW CONTROL CENTER MINIMUM VERSIONS REQUIRED FOR THE 292 HP 50 HZ 400 VAC DRIVE, 270 HP 60 HZ 380/400 VAC DRIVE		
LOCATION	PART NUMBER	MINIMUM VERSION NUMBER
YK Microboard (031-02430-001)	031-02474-001	C.OPT.01.23.307
OSCD Logic Board (031-02506-xxx) U22	031-03420-001	C.VSD.11.01.04
OSCD Logic Board (031-02506-xxx) U34	031-02547-005	C.VSD.47.01.08
OPTIVIEW CONTROL CENTER MINIMUM VERSIONS REQUIRED FOR THE 292/419 HP 50 HZ 415 VAC DRIVE, AND 385 HP 60 HZ 380/400 VAC DRIVE, 351 HP 60 HZ 460 VAC, 424 HP 60 HZ 575 VAC		
LOCATION	PART NUMBER	MINIMUM VERSION NUMBER
YK Microboard (031-02430-001)	031-02474-001	C.OPT.01.23.307
OSCD Logic Board (031-02506-xxx) U22	031-03420-001	C.VSD.11.01.04
OSCD Logic Board (031-02506-xxx) U34	031-02547-005	C.VSD.47.01.08
OPTIVIEW CONTROL CENTER MINIMUM VERSIONS REQUIRED FOR THE 419 HP 50 HZ 400 VAC DRIVE, 503 HP 60 HZ 460 VAC DRIVE		
LOCATION	PART NUMBER	MINIMUM VERSION NUMBER
Microboard (031-01730-xxx) U45	031-01796-003	C.MLM.00.03
YT Microboard (031-01730-xxx) U46	031-02004-001	C.MLM.02.04.104
YK and YKP Microboard (031-01730-xxx) U46	031-01797-001	C.MLM.01.08.105
OSCD Logic Board (031-02506-xxx) U22	031-03420-001	C.VSD.11.01.04
OSCD Logic Board (031-02506-xxx) U34	031-02547-002	C.VSD.17.01.08
OPTIVIEW CONTROL CENTER MINIMUM VERSIONS REQUIRED FOR THE 608 HP 60 HZ 575 VAC DRIVE		
LOCATION	PART NUMBER	MINIMUM VERSION NUMBER
YT Microboard (031-02430-001)	031-02469-001	C.OPT.02.09.008
YK Microboard (031-02430-001)	031-02474-001	C.OPT.01.15A.307
OSCD Logic Board (031-02506-xxx) U22	031-03420-001	C.VSD.11.01.04
OSCD Logic Board (031-02506-xxx) U34	031-02547-003	C.VSD.27.01.08
OPTIVIEW CONTROL CENTER MINIMUM VERSIONS REQUIRED FOR THE 658 HP 50 HZ 400 VAC DRIVE		
LOCATION	PART NUMBER	MINIMUM VERSION NUMBER
YK Microboard (031-02430-001)	031-02474-001	C.OPT.01.23.307
OSCD Logic Board (031-02506-xxx) U22	031W03420-001	C.VSD.11.01.04
OSCD Logic Board (031-02506-xxx) U34	031W02547-002	C.VSD.17.03.00
OPTIVIEW CONTROL CENTER MINIMUM VERSIONS REQUIRED FOR THE 704 HP 50 HZ 415 VAC DRIVE		
LOCATION	PART NUMBER	MINIMUM VERSION NUMBER
YK Microboard (031-02430-001)	031-02474-001	C.OPT.01.23.307
OSCD Logic Board (031-02506-xxx) U22	031W03420-001	C.VSD.11.01.04
OSCD Logic Board (031-02506-xxx) U34	031W02547-005	C.VSD.47.03.00
OPTIVIEW CONTROL CENTER MINIMUM VERSIONS REQUIRED FOR THE 900 HP 50 HZ 400 VAC DRIVE		
LOCATION	PART NUMBER	MINIMUM VERSION NUMBER
YK Microboard (031-02430-001)	031-02474-001	C.OPT.01.23.307
OSCD Logic Board (031-02506-xxx) U22	031W03420-001	C.VSD.11.01.04
OSCD Logic Board (031-02506-xxx) U34	031W02547-002	C.VSD.17.03.00
OPTIVIEW CONTROL CENTER MINIMUM VERSIONS REQUIRED FOR THE 900 HP 50 HZ 400 VAC DRIVE		
LOCATION	PART NUMBER	MINIMUM VERSION NUMBER
YK Microboard (031-02430-001)	031-02474-001	C.OPT.01.23.307
OSCD Logic Board (031-02506-xxx) U22	031W03420-001	C.VSD.11.01.04
OSCD Logic Board (031-02506-xxx) U34	031W02547-002	C.VSD.47.03.00

The following factors can be used to convert from English to the most common SI Metric values.

TABLE 8 - SI METRIC CONVERSION

MEASUREMENT	MULTIPLY ENGLISH UNIT	BY FACTOR	TO OBTAIN METRIC UNIT
Capacity	Tons Refrigerant Effect (ton)	3.516	Kilowatts (kW)
Power	Horsepower	0.7457	Kilowatts (kW)
Flow Rate	Gallons / Minute (gpm)	0.0631	Liters / Second (l/s)
Length	Feet (ft)	0.3048	Meters (m)
	Inches (in)	25.4	Millimeters (mm)
Weight	Pounds (lbs)	0.4536	Kilograms (kg)
Velocity	Feet / Second (fps)	0.3048	Meters / Second (m/s)
Pressure Drop	Feet of Water (ft)	2.989	Kilopascals (kPa)
	Pounds / Square Inch (psi)	6.895	Kilopascals (kPa)

TEMPERATURE

To convert degrees Fahrenheit (°F) to degrees Celsius (°C), subtract 32° and multiply by 5/9 or 0.5556.

Example: $(45.0^{\circ}\text{F} - 32^{\circ}) \times 0.5556 = 7.22^{\circ}\text{C}$

To convert a temperature range (that is, a range of 10°F) from Fahrenheit to Celsius, multiply by 5/9 or 0.5556.

Example: $10.0^{\circ}\text{F range} \times 0.5556 = 5.6^{\circ}\text{C range}$



5000 Renaissance Drive, New Freedom, Pennsylvania USA 17349
Copyright © by Johnson Controls 2017

800-861-1001
www.johnsoncontrols.com

Subject to change without notice. Printed in USA
ALL RIGHTS RESERVED

Form 160.00-M4 (1217)
Issue Date: December 19, 2017
Supersedes:160.00-M4 (516)