

 BY JOHNSON CONTROLS	<b>AIR-COOLED SCREW LIQUID CHILLERS</b>	
<b>INSTALLATION</b>	NEW RELEASE	Form 201.28-N1 (515)

**FIELD ASSEMBLY PROCEDURE FOR  
YVAA PHASE C SPLIT SHIP UNITS WITH 22 TO 26 FANS**

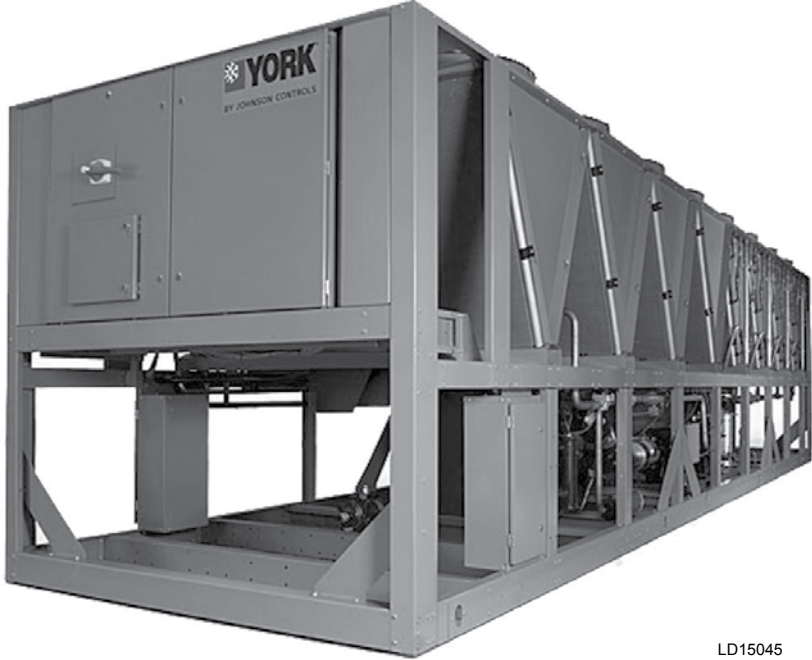

LD15045

**HFC-134A  
50 AND 60 HZ**

Issue Date:  
May 29, 2015



# IMPORTANT!

## READ BEFORE PROCEEDING!

### GENERAL SAFETY GUIDELINES

This equipment is a relatively complicated apparatus. During rigging, installation, operation, maintenance, or service, individuals may be exposed to certain components or conditions including, but not limited to: heavy objects, refrigerants, materials under pressure, rotating components, and both high and low voltage. Each of these items has the potential, if misused or handled improperly, to cause bodily injury or death. It is the obligation and responsibility of rigging, installation, and operating/service personnel to identify and recognize these inherent hazards, protect themselves, and proceed safely in completing their tasks. Failure to comply with any of these requirements could result in serious damage to the equipment and the property in

which it is situated, as well as severe personal injury or death to themselves and people at the site.

This document is intended for use by owner-authorized rigging, installation, and operating/service personnel. It is expected that these individuals possess independent training that will enable them to perform their assigned tasks properly and safely. It is essential that, prior to performing any task on this equipment, this individual shall have read and understood the on-product labels, this document and any referenced materials. This individual shall also be familiar with and comply with all applicable industry and governmental standards and regulations pertaining to the task in question.

---

### SAFETY SYMBOLS

The following symbols are used in this document to alert the reader to specific situations:



*Indicates a possible hazardous situation which will result in death or serious injury if proper care is not taken.*



*Identifies a hazard which could lead to damage to the machine, damage to other equipment and/or environmental pollution if proper care is not taken or instructions and are not followed.*



*Indicates a potentially hazardous situation which will result in possible injuries or damage to equipment if proper care is not taken.*

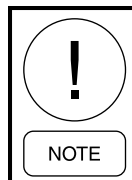

*Highlights additional information useful to the technician in completing the work being performed properly.*



*External wiring, unless specified as an optional connection in the manufacturer's product line, is not to be connected inside the control cabinet. Devices such as relays, switches, transducers and controls and any external wiring must not be installed inside the micro panel. All wiring must be in accordance with Johnson Controls' published specifications and must be performed only by a qualified electrician. Johnson Controls will NOT be responsible for damage/problems resulting from improper connections to the controls or application of improper control signals. Failure to follow this warning will void the manufacturer's warranty and cause serious damage to property or personal injury.*

## CHANGEABILITY OF THIS DOCUMENT

In complying with Johnson Controls' policy for continuous product improvement, the information contained in this document is subject to change without notice. Johnson Controls makes no commitment to update or provide current information automatically to the manual or product owner. Updated manuals, if applicable, can be obtained by contacting the nearest Johnson Controls Service office or accessing the Johnson Controls QuickLIT website at <http://cgproducts.johnsoncontrols.com>.

It is the responsibility of rigging, lifting, and operating/service personnel to verify the applicability of these documents to the equipment. If there is any question

regarding the applicability of these documents, rigging, lifting, and operating/service personnel should verify whether the equipment has been modified and if current literature is available from the owner of the equipment prior to performing any work on the chiller.

### CHANGE BARS

Revisions made to this document are indicated with a line along the left or right hand column in the area the revision was made. These revisions are to technical information and any other changes in spelling, grammar or formatting are not included.



***The Control/VSD Cabinet contains lethal high AC and DC voltages. Before performing service inside the cabinet, remove the AC supply feeding the chiller and verify using a non-contact voltage sensor.***



***The DC voltage on the VSD DC Bus will take 5 minutes to bleed off, after AC power is removed. Always check the DC Bus Voltage with a Voltmeter to assure the capacitor charge has bled off before working on the system.***



***NEVER short out the DC Bus to discharge the filter capacitors.***



***NEVER place loose tools, debris, or any objects inside the Control Panel/VSD Cabinet.***



***NEVER allow the Control Panel VSD Cabinet doors to remain open if there is a potential for rain to enter the panel. Keep doors closed and assure all latches are engaged on each door unless the unit is being serviced.***



***ALWAYS lockout the disconnect supplying AC to the chiller.***



***The 1L Line Inductor will reach operating temperatures of over 150°C (300°F) DO NOT open panel doors during operation. Assure the inductor is cool whenever working near the inductor with power OFF.***

## ASSOCIATED LITERATURE

MANUAL DESCRIPTION	FORM NUMBER
Equipment Pre-Startup and Startup Checklist	201.28-CL2
Installation, Operation and Maintenance	201.28-NM1.1

## NOMENCLATURE

# YVAA 044 3AXX 46 AA

**1** BASE PRODUCT TYPE

**2** **3** **4**

Y V A A

- Y : York
- V : Variable Speed Screw
- A : Air cooled
- A : Design Series

**5** **6** **7** FRAME SIZE

# # #

**8** **9** **10** **11** CONFIGURATION

# # # #

- # : Condenser code
- # : Evaporator code
- # : Compressor code
- # : Condenser fan & sound kit code

**12** **13** VOLTAGE

1 7 : 200 / 3 / 60

2 8 : 230 / 3 / 60

4 0 : 380 / 3 / 60

4 2 : 400 / 3 / 60

4 6 : 460 / 3 / 60

5 0 : 380-415 / 3 / 50

5 8 : 575 / 3 / 60

**14** **15** LEVEL / REFRIGERANT

# A

- # : Development Level
- A : Refrigerant R134a

**TABLE 1 - SPLIT SHIP UNITS MODELS**

UNIT MODEL	SYS 1 & 2 FAN QTY	MAIN/SUB SECTION FAN QTY	MAIN SECTION SYS 2 FAN QTY	SYS 1 REF. QTY (LB/KG)	SYS 2 REF QTY (LB/KG)
<b>0443</b> <b>1543</b>	12/12	20/4	8	370/168	370/168
<b>0483</b> <b>1693</b>	13/13	20/6	7	385/175	385/175
<b>0523</b> <b>1843</b>	13/13	20/6	7	445/202	445/202
<b>0425</b> <b>0475</b>	14/10	20/4	6	480/217	365/165
<b>0475</b> <b>1665</b>	13/13	20/6	7	445/202	445/202
<b>0368</b> <b>1288</b>	14/8	18/4	4	475/215	320/145
<b>0398</b> <b>1388</b>	14/10	20/4	6	475/215	360/163
<b>0428</b> <b>1488</b>	14/12	20/6	6	475/215	385/175

## FIELD ASSEMBLY PROCEDURE FOR YVAA SPLIT UNITS



# WARNING

Failure to follow these instructions could result in death, serious injury or equipment damage.

**Follow all warnings and instructions in the unit's Manual(s).**

<p><b>EN</b> Installation Instructions for the technician / fitter</p> <p><b>PL</b> Instrukcja instalacji dla technika / monter</p> <p><b>SV</b> Installationsguide for installer / montör</p> <p><b>CS</b> Pokyny k instalaci pro techniky a montéry</p>	<p><b>IT</b> Istruzioni d'installazione per il personale specializzato</p> <p><b>NL</b> Installatiehandleiding voor de vakman / monteur</p> <p><b>DE</b> Installationsanleitung für die Fachkraft / Monteur</p> <p><b>ES</b> Instrucciones de instalación para el técnico / contratista especializado</p>	<p><b>JA</b> 一般仕様・取扱説明書</p> <p><b>FR</b> Manuel d'installation pour le spécialiste / monteur</p> <p><b>RU</b> Инструкция по установке для техника/монтажника</p> <p><b>ZH</b> 适用于技术人员与安装人员的 安装说明书</p>
---	---	---



1. Follow all applicable regulations and safety practices during rigging and lifting.
2. Prepare and follow written rigging and lifting plan.
3. Rigging must be directed by trained professional rigger.
4. Spreader bars must be used and be long enough to prevent rigging from contacting unit.
5. Use all and only designated lift points according to units manual(s).
6. Locate center of gravity through trial lifts to account for possible variations in unit configuration.
7. Use rigging and lifting techniques that keep unit stable and level.
8. Keep clear of unit when lifted.

035-23962-000 REV A

LD19197



*Rigging and lifting should only be done by a professional rigger in accordance with a written rigging and lifting plan. The most appropriate rigging and lifting method will depend on job specific factors, such as the rigging equipment available and site needs. Therefore, a professional rigger must determine the rigging and lifting method to be used, and it is beyond the scope of this manual to specify rigging and lifting details.*

### LIFTING WEIGHTS

Refer to the unit nameplate for unit shipping weight. Note that weight may vary depending on unit configuration at the time of lifting. Refer to the Physical Data tables within this manual for further information regarding shipping and operating weights.

### DELIVERY AND STORAGE

To ensure consistent quality and maximum reliability, all units are tested and inspected before leaving the factory. Units are shipped completely assembled and containing refrigerant under pressure. Units are shipped without export crating unless crating has been specified on the Sales Order.

If the unit is to be put into storage, prior to installation, the following precautions should be observed:

- The chiller must be “blocked” so that the base is not permitted to sag or bow.
- Ensure that all openings, such as water connections, are securely capped.
- Do not store where exposed to ambient air temperatures exceeding 43°C (110°F).

- The condensers should be covered to protect the coils and fins from potential damage and corrosion, particularly where building work is in progress.
- The unit should be stored in a location where there is minimal activity in order to limit the risk of accidental physical damage.
- To prevent inadvertent operation of the pressure relief devices the unit must not be steam cleaned.
- It is recommended that the unit is periodically inspected during storage.

### INSPECTION

Remove any transit packing and inspect the unit to ensure that all components have been delivered and that no damage has occurred during transit. If any damage is evident, it should be noted on the carrier’s freight bill and a claim entered in accordance with the instructions given on the advice note.

Major damage must be reported immediately to your local Johnson Controls representative.

## MOVING THE CHILLER

Prior to moving the unit, ensure that the installation site is suitable for installing the unit and is easily capable of supporting the weight of the unit and all associated services.



***The unit must only be lifted by the base frame at the points provided. Never move the unit on rollers, or lift the unit using a forklift truck.***

Care should be taken to avoid damaging the condenser cooling fins when moving the unit.

## UNIT REMOVAL FROM SHIPPING CONTAINER

1. Place a clevis pin into the holes provided at the end of each base rail on the unit. Attach chains or nylon straps through the clevis pins and hook onto a suitable lift truck for pulling the unit out of the container.
2. Slowly place tension on the chains or straps until the unit begins to move and then slowly pull the unit from the container. Be sure to pull straight so the sides do not scrape the container.
3. Place a lifting fixture on the forks of the lift truck and reattach the chain or strap. Slightly lift the front of the unit to remove some weight from the floor of the container. Continue pulling the unit with an operator on each side to guide the lift truck operator.
4. Pull the unit until the lifting locations are outside of the container. Place 4 X 4 blocks of wood under the base rails of the unit. Gently rest the unit on the blocks and remove the chains and lift truck.
5. Attach lifting rigging from the crane and slowly complete the removal from the container then lift up and away.



LD19197a

## LIFTING USING LUGS

Units are provided with lifting holes in the base frame which accept the accessory lifting lug set as shown in the figure below. The lugs (RH and LH) should be inserted into the respective holes in the base frame and turned so that the spring loaded pin engages into the hole and the flanges on the lug lock behind the hole. The lugs should be attached to the cables/chains using shackles or safety hooks.

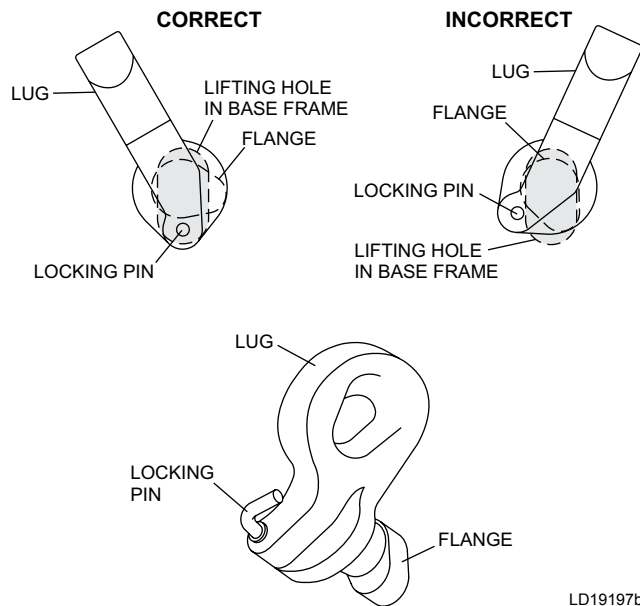

LD19197b

## LIFTING USING SHACKLES

The shackles should be inserted into the respective holes in the base frame and secured from the inside.

Use spreader bars to avoid lifting chains hitting the chiller. Various methods of spreader bar arrangements may be used, keeping in mind the intent is to keep the unit stable and to keep the chains from hitting the chiller and causing damage.

Never lift the chiller using a forklift or by hooking to the top rails. Use only the lifting holes provided.

Lifting Instructions are placed on a label on the chiller and on the shipping bag.

During this procedure operators will be exposed to lethal voltages and the operators must be qualified to complete wiring work under these conditions. Risk assessments should be conducted to ensure all appropriate precautions are taken. The operators must comply with all of Johnson Controls, Inc, electrical safety requirements including "Lock-Out/Tag-Out" procedures and wearing PPE (Personal Protective Equipment) gear prior to performing the procedure.

## SCOPE

This procedure covers the assembly and shipment of the YVAA Phase C Split Units (with total fan quantities between 22 and 26), to be used by the field service teams.

During this procedure operators will be exposed to lethal voltages and the operators must be qualified to complete wiring work under these conditions. Risk assessments should be conducted to ensure all appropriate precautions are taken. The operators must comply with all of Johnson Controls, Inc, electrical safety requirements including "Lock-Out/Tag-Out" procedures and wearing PPE (Personal Protective Equipment) gear prior to performing the procedure.

## FIELD ASSEMBLY PROCEDURE

1. Upon arrival on customer site, follow installation procedure as specified in "YVAA: Installation, Operation, and Maintenance" document (Section 4).

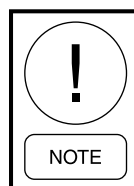

**Refer to the Installation, Operation and Maintenance Manual (Form 201.28-NM1.1) for lifting suggestions and more details on lifting point locations.**

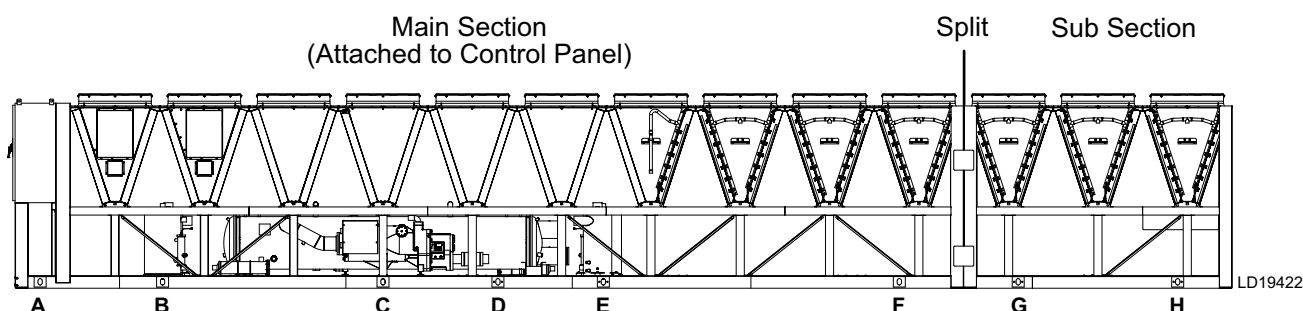

**FIGURE 1 - UNIT AS ASSEMBLED**

Use these Charts for lifting separated main section and sub-section units individually.

SEE 035-23515-002 FOR RIGGING	MAIN SECTION LIFT POINTS DIMENSIONS TAKEN FROM POWER PANEL END OF UNIT												
	MODEL	A		B		C		D		E		F	
		Inch	Metric	Inch	Metric	Inch	Metric	Inch	Metric	Inch	Metric	Inch	Metric
USE FIGURE 1	0368/1288	12.3	314	72.6	1845	181.1	4602	237.7	6039	301.6	7662	391.3	9942
	0398/1388	12.3	314	72.6	1845	181.1	4602	237.7	6039	301.6	7662	435.3	11059
	0425/1515	12.3	314	72.6	1845	181.1	4602	237.7	6039	301.6	7662	435.3	11059
	0443/1543	12.3	314	72.6	1845	181.1	4602	237.7	6039	289.6	7358	435.3	11059
	0428/1488	12.3	314	72.6	1845	181.1	4602	237.7	6039	301.6	7662	435.3	11059
	0475/1665	12.3	314	72.6	1845	181.1	4602	237.7	6039	289.6	7358	435.3	11059
	0483/1693	12.3	314	72.6	1845	181.1	4602	237.7	6039	289.6	7358	435.3	11059
	0523/1843	12.3	314	72.6	1845	181.1	4602	237.7	6039	289.6	7358	435.3	11059
	SUB SECTION LIFT POINTS DIMENSIONS TAKEN FROM END OF SUB SECTION												
	MODEL	G										H	
	0368/1288	10.7	271									77.6	1971
	0398/1388	10.7	271									77.6	1971
	0425/1515	10.7	271									77.6	1971
	0443/1543	10.7	271									77.6	1971
0428/1488	26.8	681									105.3	2676	
0475/1665	26.8	681									105.3	2676	
0483/1693	26.8	681									105.3	2676	
0523/1843	26.8	681									105.3	2676	

2. Upon arrival AT the site, check that the sub section is still pressurized with 10-15 PSI of nitrogen, and then relieve pressure via the relief valve.
3. Once situated, align the main and sub section flange plates. Remove the flange plates and bolt the two sections together with gaskets to the correct torque value as shown in Figures 2 and 3.

4. Pump down the portion of the unit downstream of the ball valves in the main section (the sub section and the last condenser module in the main section).

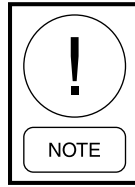

***Do not open discharge and liquid line ball valves until there is sufficient water flow through the evaporator.***

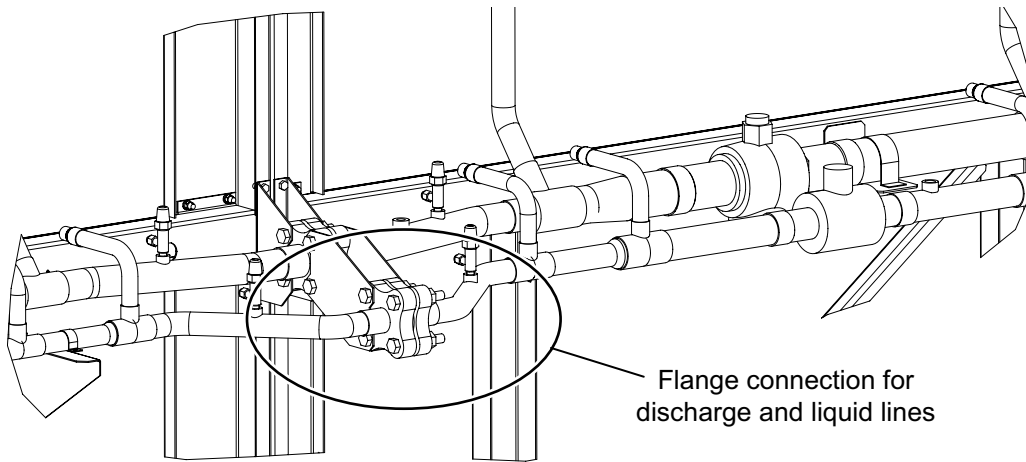

LD19423

**FIGURE 2 - FLANGE CONNECTION FOR DISCHARGE AND LIQUID LINES (VIEW FROM INSIDE UNIT)**

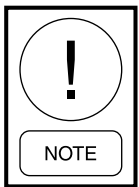

***Piping and connecting flanges is done for each circuit.***

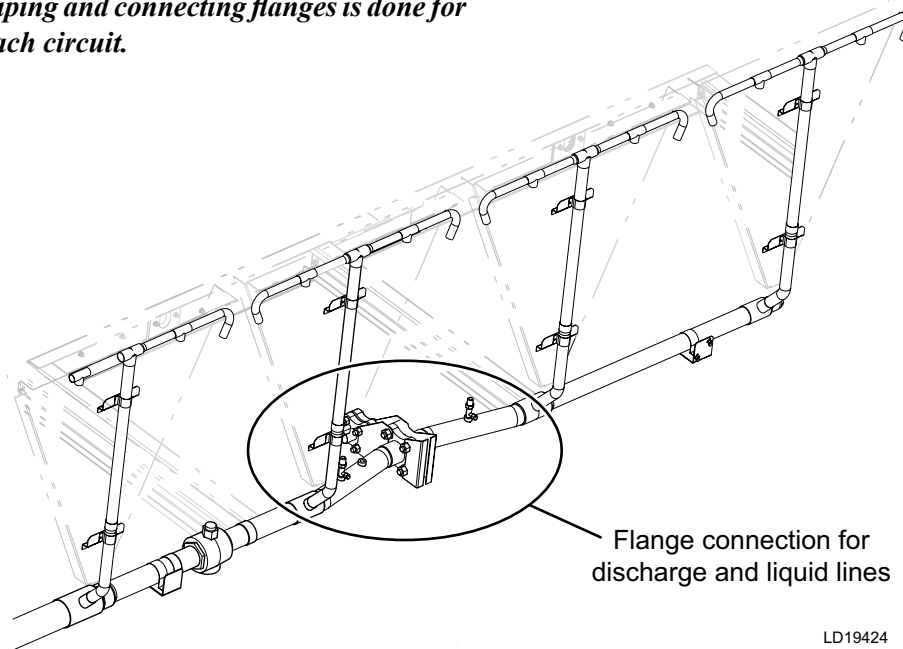

LD19424

**FIGURE 3 - FLANGE CONNECTION FOR DISCHARGE AND LIQUID LINES (VIEW FROM OUTSIDE UNIT)**

5. Connect main and sub section wiring to the appropriate junction boxes as shown in *Figure 5*.

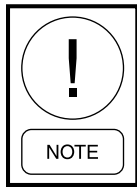

***Be sure to leak check flanges between the Main and Sub Sections before applying power to the unit to confirm a secure seal between the two sections.***

6. Perform continuity checks and fan rotation checks to ensure fans on the sub section operate properly.
7. Complete the rest for the standard commissioning procedure as specified in the Equipment Pre-startup and Startup Checklist (Form 201.28-CL2) and the Installation, Operation and Maintenance Manual (Form 201.28-NM1.1).

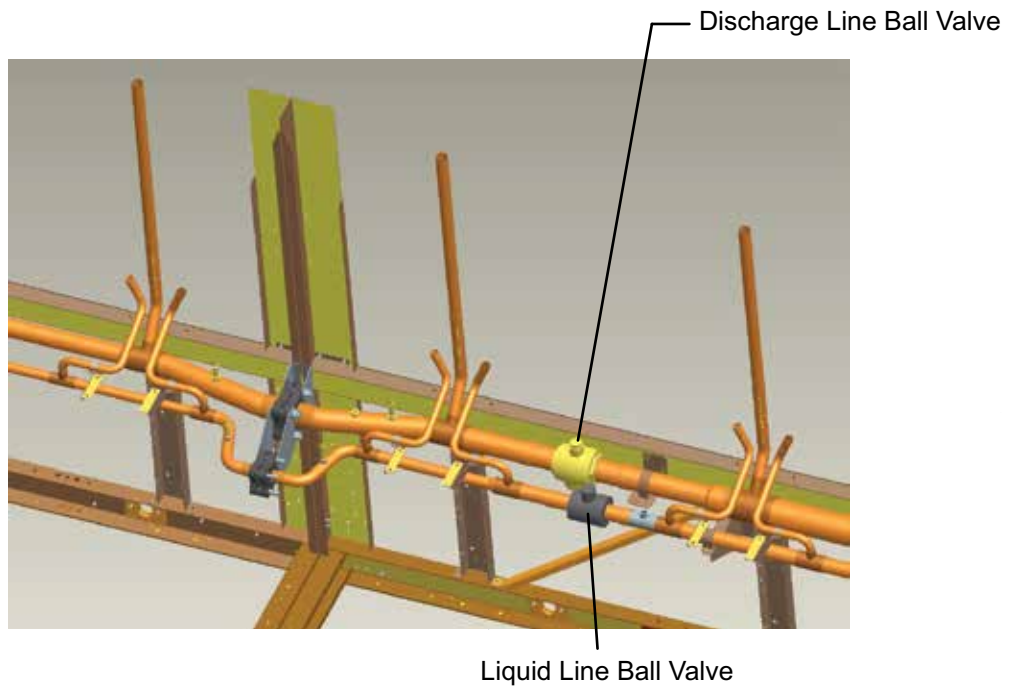

**FIGURE 4 - DISCHARGE LINE BALL VALVE**

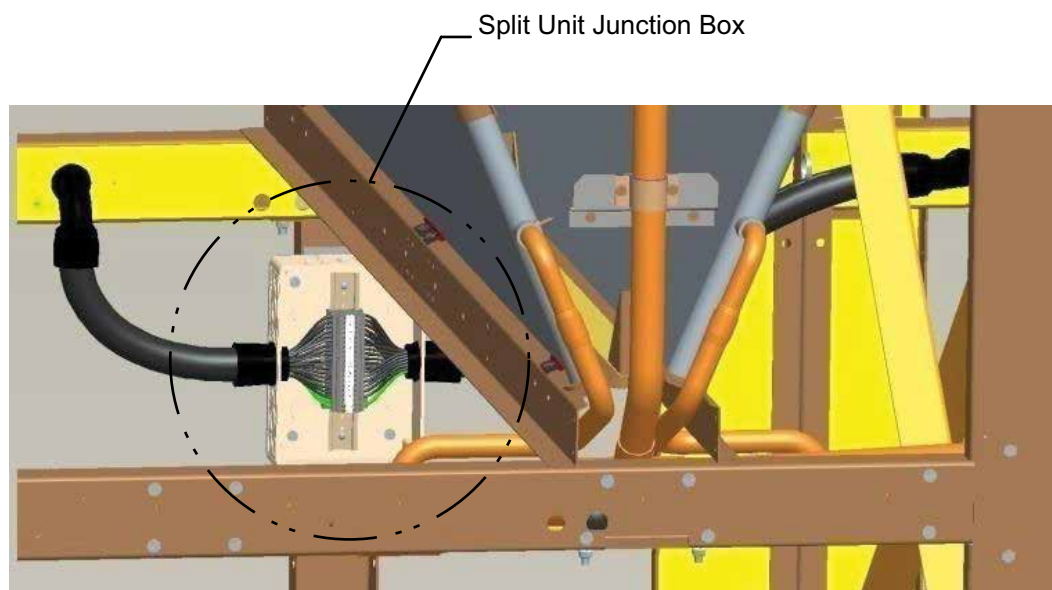

**FIGURE 5 - WIRING HARNESS ELECTRICAL CONNECTION**



P.O. Box 1592, York, Pennsylvania USA 17405-1592  
Copyright © by Johnson Controls 2015  
Form xxx.xx-xx (515)  
Issue Date: May 29, 2015  
New Release

800-861-1001  
[www.johnsoncontrols.com](http://www.johnsoncontrols.com)

Subject to change without notice. Printed in USA  
ALL RIGHTS RESERVED